

RACM140E-K Series \diamond AC/DC Power Supply

140W (210W/10s) \diamond Input: 100V-240VAC

FEATURES

- Cost-efficient and reliable Design
- 210W boost power up to 10s
- Over voltage category OVC III; 2000m
- 5000m operating altitude
- Open Frame or enclosed; optional: Push-In connectors
- 2MOPP reinforced isolation, BF applicable
- 3 year warranty



Open frame: 147.0 x 81.5 x 38.0mm (5.7 x 3.2 x 1.5 inch)
 Enclosed: 147.0 x 81.5 x 40.0mm (5.7 x 3.2 x 1.6 inch)

APPLICATIONS

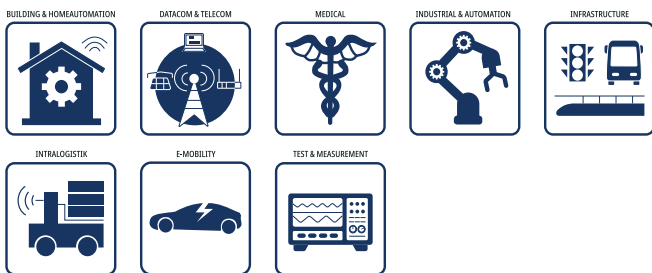

SAFETY & EMC



DESCRIPTION

Cost efficiency and reliability characterize the RACM140E-K AC/DC power supplies, delivering a continuous output of 140 watts and a boost power of 210 watts for dynamic load surges lasting up to 10 seconds. Mounting options include industry-standard 3"x5" screw points or robust tabs, allowing direct installation from above onto base plates. Connection to be facilitated through a wiring harness and pin headers, or via optional tool-less 'push-in' terminals. Certified for household and industrial standards with overvoltage category OVC III respectively OVC II for operation up to 5000 meters altitude, the series additionally holds UL certifications with 2MOPP and complies with BF requirements for medical use. To simplify system integration, the modules offer ample margin to EN55032 'B' limits and increased 'Surge and Burst' immunity. Covering a wide range of DC output requirements. output voltages can be adjusted by $\pm 20\%$ on average, using a trim potentiometer.

SELECTION GUIDE

Part Number	Operating Input Range [VAC]	Output Voltage nom. [VDC]	Output Adjustability [VDC]	rated Output Current ⁽¹⁾ [A]	Efficiency ⁽²⁾ typ. [%]	rated Output Power ⁽¹⁾ [W]
RACM140E-12SK ⁽³⁾	80-264	12	12-18	11.6	86	140W
RACM140E-15SK ⁽³⁾	80-264	15	12-18	9.3	87	140W
RACM140E-24SK ⁽³⁾	80-264	24	22-28	5.8	88	140W
RACM140E-36SK ⁽³⁾	80-264	36	30-36	3.8	90	136.8W
RACM140E-48SK ⁽³⁾	80-264	48	48-54	2.9	90	140W

Note1: Refer to „PEAK LOAD Capability“.

Note2: Efficiency is tested at nominal input and rated load at +25°C ambient.

RACM140E-K Series \diamond AC/DC Power Supply

140W (210W/10s) \diamond Input: 100V-240VAC

MODEL NUMBERING



Note3: "/OF" = 5.7" x 3.2" open frame version, u-channel.

"/ENC" = 5.7" x 3.2" enclosed version (15Vout & 36Vout, on request).

"/PT/ENC" = 5.7" x 3.2" enclosed version with push in terminals (on request).

ORDERING INFORMATION

Model	nom. Output Voltage	Package Type		
		5.7" x 3.2" open frame "/OF"	5.7" x 3.2" enclosed "/ENC"	5.7" x 3.2" enclosed with push-in terminals "/PT/ENC"
RACM140E-12SK	12VDC	x	x	on request
RACM140E-15SK	15VDC	x	on request	on request
RACM140E-24SK	24VDC	x	x	on request
RACM140E-36SK	36VDC	x	on request	on request
RACM140E-48SK	48VDC	x	x	on request

x= standard portfolio / on request= MOQ may apply on project base / N/A= not available

BASIC CHARACTERISTICS (measured @ T_{AMB} = 25°C, nom. V_{IN}, full load and after warm-up unless otherwise stated)

Parameter	Condition	Min.	Typ.	Max.	
Nominal Input Voltage	50/60Hz	100VAC		240VAC	
Operating Range ⁽⁴⁾	47-63Hz	80VAC		264VAC	
	DC	120VDC		370VDC	
Input Current	115VAC			3A	
	230VAC			2A	
Inrush Current	cold start at 25°C	115VAC		30A	
		230VAC		60A	
No Load Power Consumption			100mW		
Ecodesign Standby Mode Use (Available output power for stated input power)	115/230VAC	P _{IN} = 0.3W		100mW	
		P _{IN} = 0.5W		300mW	
		P _{IN} = 1.0W		770mW	
Input Frequency Range	AC input	47Hz		63Hz	
Output Voltage Adjustability ⁽⁵⁾	on-board trim potentiometer	RACM140E-12SK	12VDC		18VDC
		RACM140E-15SK	12VDC		18VDC
		RACM140E-24SK	22VDC		28VDC
		RACM140E-36SK	30VDC		36VDC
		RACM140E-48SK	48VDC		54VDC
Minimum Load		0%			
Power Factor	115VAC		0.6		
	230VAC		0.5		
Start-up time	230VAC		200ms	300ms	
Rise time	230VAC			20ms	
Hold-up time	115VAC	10ms			
	230VAC	20ms			
Internal Operating Frequency				100kHz	
Output Ripple and Noise ⁽⁶⁾	20MHz BW	T _{AMB} = +25°C		1% of Vout	

Note4: The products were submitted to all safety files at AC-operation.

Note5: Make sure that the maximum rated output power will not be exceeded when trimming up.

Note6: Measurements are made with a 0.1µF MLCC & 10µF E-cap in parallel across output (low ESR).

The test setup can have an impact on ripple noise values (placement of scope probe, capacitors, it's specifications, wires, PCB tracks, distances, etc.)

RACM140E-K Series \diamond AC/DC Power Supply

140W (210W/10s) \diamond Input: 100V-240VAC

BASIC CHARACTERISTICS (measured @ $T_{AMB} = 25^{\circ}\text{C}$, nom. V_{IN} , full load and after warm-up unless otherwise stated)

Efficiency vs Output Power

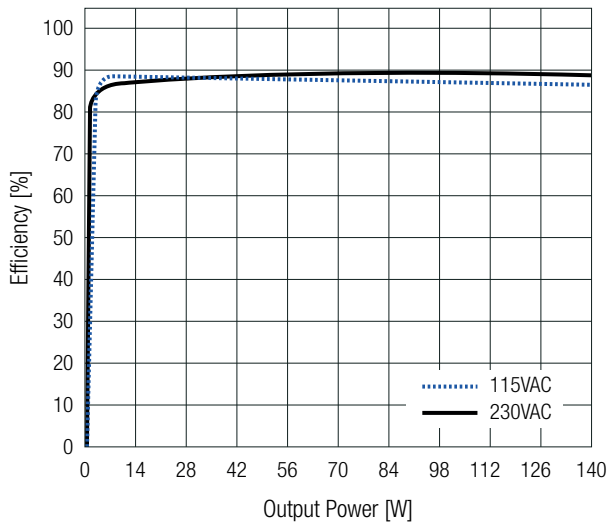

Power Dissipation vs. Output Power

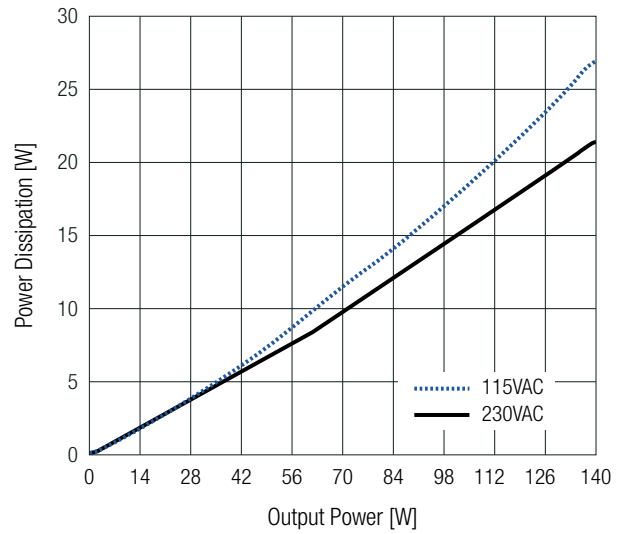

REGULATIONS (measured @ $T_{AMB} = 25^{\circ}\text{C}$, nom. V_{IN} , full load and after warm-up unless otherwise stated)

Parameter	Condition	Value
Output Accuracy		$\pm 2.0\%$ typ.
Line Regulation	low line to high line, full load	$\pm 0.5\%$ typ.
Load Regulation ⁽⁷⁾	10% to 100% load	2.0% typ.
Transient Response	25% load step change	4.0% max.
	recovery time	500 μs typ.

Note7: Operation below 10% load will not harm the converter, but specifications may not be met.

Deviation vs. Load

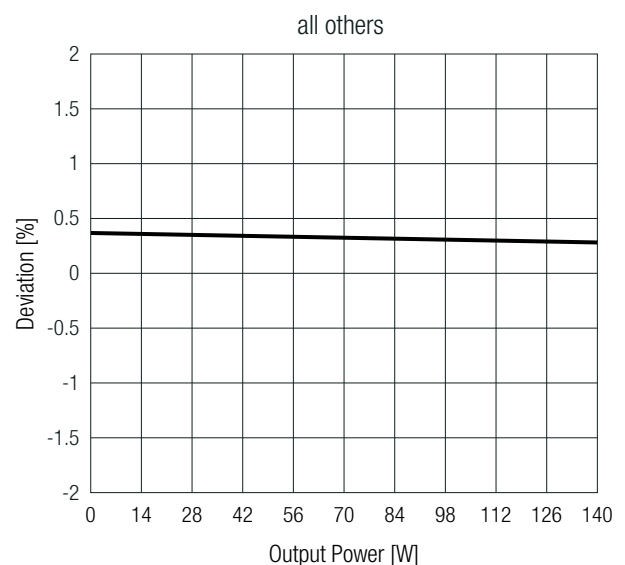
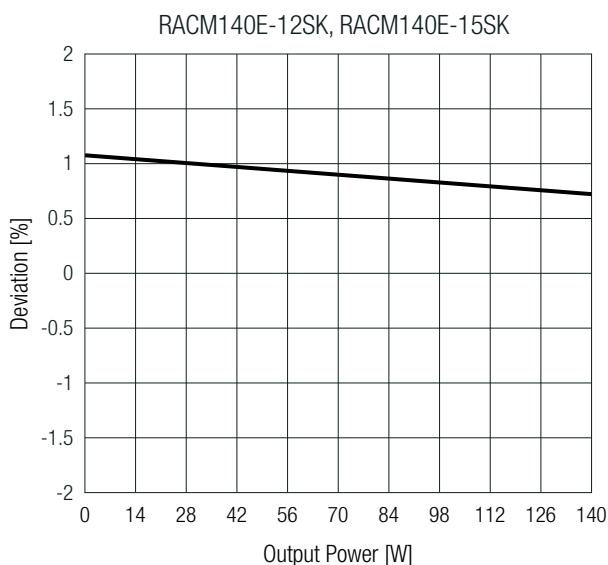

RACM140E-K Series \diamond AC/DC Power Supply

140W (210W/10s) \diamond Input: 100V-240VAC

PROTECTIONS (measured @ $T_{AMB}=25^{\circ}\text{C}$, nom. V_{IN} , full load and after warm-up unless otherwise stated)

Parameter	Type		Value
Internal Input Fuse ⁽⁸⁾	dual-fusing (line & neutral)		2x T6.3A, slow blow type
Short Circuit Protection (SCP)	below 100m Ω		hiccup mode
Over Voltage Protection (OVP)	hiccup mode	RACM140E-12SK; RACM140E-15SK	30VDC max.
		RACM140E-24SK	40VDC max.
		RACM140E-36SK	48VDC max.
		RACM140E-48SK	65VDC max.
Over Voltage Category (OVC)	according to 61558		OVC III (2000m)
	according to 60601-1, 62368-1, 60335-1		OVC II (5000m)
Over Current Protection (OCP)			<200%, hiccup mode
DC ON LED			green light, output voltage present
Class of Equipment	with PE connection		Class I
Isolation Voltage ⁽⁹⁾	I/P to O/P	1 minunte	according to 61558
			according to 62368-1
Isolation Resistance	I/P to O/P, $V_{ISO}=500\text{VDC}$		1G Ω min.
Isolation Capacitance	I/P to O/P, 100kHz/0.1V		100pF max.
Insulation Grade	I/P to O/P		reinforced
Means of Protection	I/P to O/P		2MOPP
Medical Device Classification	built-in power supply		designed to support type BF applications
Touch Current	normal condition		<100 μA
	single fault		<500 μA
Earth Leakage Current (Input and Output to Earth (GND))	264VAC/63Hz	normal condition	<300 μA

Note8: For system integration with DC operation, consider a suitable DC fuse in front of the input.

Note9: For repeat Hi-Pot testing, reduce the time and/or the test voltage.

ENVIRONMENTAL (measured @ $T_{AMB}=25^{\circ}\text{C}$, nom. V_{IN} , full load and after warm-up unless otherwise stated)

Parameter	Condition		Value
Operating Ambient Temperature Range	@ natural convection (0.1m/s)	refer to „Derating Graph“	-40 $^{\circ}\text{C}$ to +90 $^{\circ}\text{C}$
Temperature Coefficient			$\pm 0.02\%/K$
Operating Altitude ⁽¹⁰⁾	according to 62368-1, 60601-1, 60335-1		5000m (OVC II)
	according to 61558		2000m (OVC III)
Operating Humidity	non-condensing		90% RH max.
Pollution Degree			PD2
Vibration	according to MIL-STD-202G		10-500Hz, 2G 10min./1cycle, period, 60min. each along x,y,z axes
MTBF	according to MIL-HDBK-217, G.B.	$T_{AMB}=+25^{\circ}\text{C}$	440 x 10 ³ hours
		$T_{AMB}=+40^{\circ}\text{C}$	400 x 10 ³ hours
Design Lifetime	230VAC, full load	$T_{AMB}=+45^{\circ}\text{C}$	RACM140E-12SK 30 x 10 ³ hours
		$T_{AMB}=+50^{\circ}\text{C}$	others 50 x 10 ³ hours

Note10: Recognized by safety agency for safe operation up to 5000m. High altitude operation may impact the performance and lifetime.
Please contact RECOM tech support for advice.

ENVIRONMENTAL (measured @ $T_{AMB} = 25^{\circ}\text{C}$, nom. V_{IN} , full load and after warm-up unless otherwise stated)

Derating Graph

(@ Chamber and natural convection 0.1m/s)

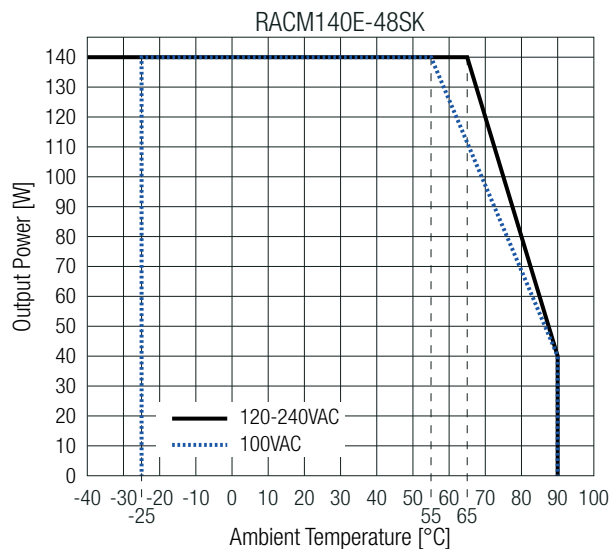
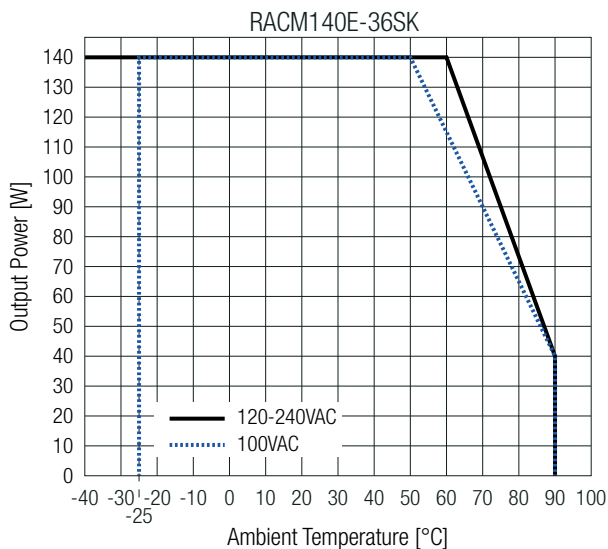
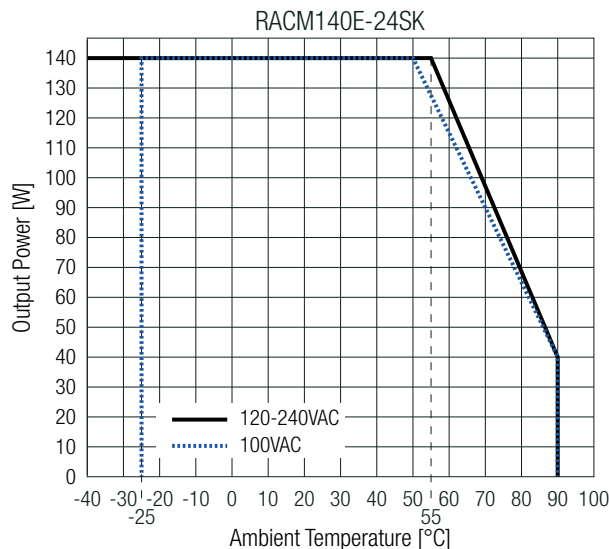
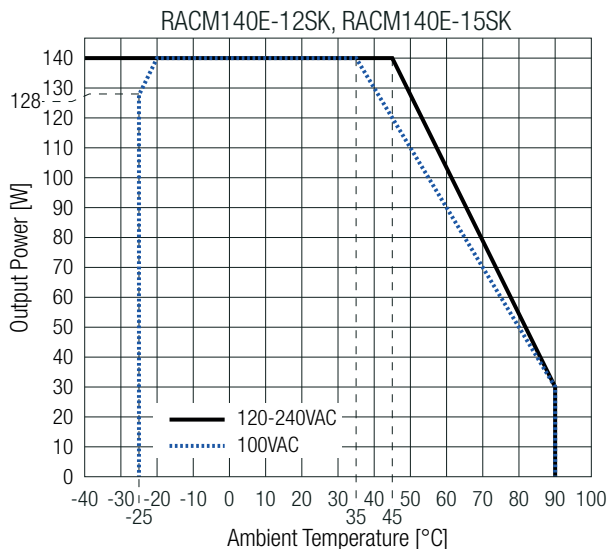

PEAK LOAD CAPABILITY

Peak Load calculation for recurrent dynamic loading (at natural convection 0.1m/s)

Parameters	Units	RACM140E-12SK RACM140E-15SK	RACM140E-24SK	RACM140E-36SK RACM140E-48SK
P_{rated} = rated output power	[W]	refer to „Derating Graph“		
P_p = peak output power	[W]	180W max.	210W max.	210W max.
P_r = recovery output power	[W]	use calculation below		
t_1 = peak time set	[s]	10s max.		
t_2 = recovery time	[s]	min. $5 \times t_1$		
k = heat dissipation factor	[]	1.1	1.0	0.9

Calculation:

$$P_r = \frac{P_{rated} \times (t_1 + t_2) - (P_p \times t_1)}{t_2 \times k}$$

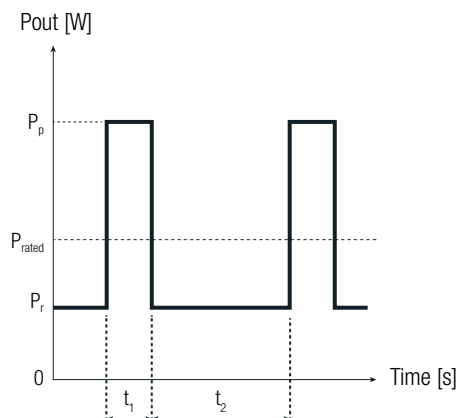

Practical Example (RACM140E-48SK for still air convection):

Take the RACM140E-48SK at 240VAC input voltage and at $T_{AMB} = 70^{\circ}\text{C}$, with still air convection.

- $P_p = 210\text{W}$
- $P_{rated} = 120\text{W}$
- $t_1 = 10\text{s}$
- $t_2 = 5 \times t_1$
- $k = 1.0$

$$P_r = \frac{120 \times (10 + 50) - (210 \times 10)}{50 \times 1} = 102\text{W}$$

RACM140E-K Series \diamond AC/DC Power Supply

140W (210W/10s) \diamond Input: 100V-240VAC

SAFETY & CERTIFICATIONS

Certificate Type (Safety)	Report Number	Standard
Audio/Video, information and communication technology equipment - Part1: Safety requirements	085-230345101	EN IEC 62368-1:2020+A11:2020
Audio/Video, information and communication technology equipment - Safety requirements (CB)	-000	IEC62368-1:2018 3rd Edition
Medical electrical equipment Part 1: General requirements for basic safety and essential performance (CB)	230731004	IEC60601-1:2005+AM2:2020 Edition 3.2
Medical electrical equipment Part 1: General requirements for basic safety and essential performance		EN60601-1:2006+A2:2021
Medical electrical equipment Part 1: General requirements for basic safety and essential performance	E511305-D6003-UL	ANSI/AAMI ES60601-1:2005+A2:2010/(R)2012
		CAN/CSA-C22.2 No. 60601-1:14 3rd Edition
Household and similar electrical appliances – Safety – Part 1: General requirements		IEC60335-1:2010+C1:2016 5th Edition
	64.260.23.03453.01	EN60335-1:2012+A15:2021
Measurement methods for electromagnetic fields of household appliances and similar apparatus with regard to human exposure		EN62233:2008
Safety of power transformers, power supplies, reactors and similar products for supply voltages up to 1100 V 3rd Edition		IEC61558-1:2017 3rd Edition
Safety of power transformers, power supplies, reactors and similar products for supply voltages up to 1100 V 3rd Edition		EN IEC 61558-1:2019
Safety of power transformers, power supplies, reactors and similar products for supply voltages up to 1100 V Part 2: Particular requirements	085-230345201-100	IEC61558-2-16:2009+A1:2013 1st Edition
Safety of power transformers, power supplies, reactors and similar products for supply voltages up to 1100 V Part 2: Particular requirements		EN61558-2-16:2009+A1:2013
RoHS2		RoHS-2011/65/EU + AM-2015/863

EMC Compliance according to EN60601-1-2	Condition	Standard
Medical electrical equipment Part 1-2: General requirements for basic safety and essential performance ⁽¹¹⁾		EN60601-1-2:2015+A1:2021
ESD Electrostatic discharge immunity test	Contact ± 4 , 8kV	IEC61000-4-2:2009 EN61000-4-2:2008
Radiated, radio-frequency, electromagnetic field immunity test	10 V/m (80-2700MHz), 27V/m (385MHz), 28V/m (450MHz), 9V/m (710, 745, 780MHz), 28V/m (810, 870, 930MHz), 28V/m (1720, 1845, 1970MHz), 28V/m (2450MHz), 9V/m (5240, 5500, 5785MHz)	IEC/EN61000-4-3:2006 + A2:2010
Fast Transient and Burst Immunity ⁽¹¹⁾	L, N, PE, L-N, L-PE, N-PE, L-N-PE: ± 2 kV	IEC/EN61000-4-4:2012
Surge Immunity ⁽¹¹⁾	L-N: ± 0.5 , 1, 2kV L-PE, N-PE: ± 4 kV	IEC/EN61000-4-5:2014 + A1:2017
Immunity to conducted disturbances, induced by radio-frequency fields	3, 6Vrms (0.15-80MHz)	IEC61000-4-6:2013 EN61000-4-6:2014
Power Magnetic Field Immunity	30A/m	EN61000-4-8:2010
Voltage Dips and Interruptions	Dips: 100% (0.5P, 1.0P); 30% Interruption: 100%	EN61000-4-11:2004 + A1:2017
Limits of Harmonic Current Emissions	$P_{out} = 112$ W	EN61000-3-2:2005+A1+A2:2009
Limits of Voltage Fluctuations & Flicker		EN61000-3-3:2013

EMC Compliance according to EN61204-3	Condition	Standard / Criterion
Low voltage power supplies, d.c. output Part 3: Electromagnetic compatibility (EMC) ⁽¹¹⁾		EN IEC 61204-3:2018, Class B
ESD Electrostatic discharge immunity test	Contact: ± 4 kV	EN61000-4-2:2008, Criteria A IEC61000-4-2:2009, Criteria A
Radiated, radio-frequency, electromagnetic field immunity test	10V/m (80-1000MHz), 3V/m (1400-2000MHz), 1V/m (2000-2700MHz)	IEC/EN61000-4-3:2006 + A2:2010, Criteria A
Fast Transient and Burst Immunity ⁽¹¹⁾	L, N, PE, L-N, L-PE, N-PE, L-N-PE: ± 2 kV	IEC/EN61000-4-4:2012, Criteria A
Surge Immunity ⁽¹¹⁾	L-N: ± 0.5 , 1, 2kV L-PE, N-PE: ± 4 kV	IEC/EN61000-4-5:2014 + A1:2017, Criteria A

SAFETY & CERTIFICATIONS

EMC Compliance according to EN61204-3	Condition	Standard / Criterion
Immunity to conducted disturbances, induced by radio-frequency fields	10Vrms (0.15-80MHz)	IEC61000-4-6:2013, Criteria A EN61000-4-6:2014, Criteria A
Power Magnetic Field Immunity	30A/m	IEC61000-4-8:2009, Criteria A EN61000-4-8:2010, Criteria A
Voltage Dip	100% (0.5P, 1.0P); 20%, 30%, 60%	EN61000-4-11:2004 + A1:2017, Criteria A
Voltage Interruptions	100%	EN61000-4-11:2004 + A1:2017, Criteria B
Limits of Harmonic Current Emissions	$P_{out} = 112W$	EN61000-3-2:2005+A1+A2:2009
Limits of Voltage Fluctuations & Flicker		EN61000-3-3:2013
EMC Compliance according to EN35032/55035	Condition	Standard / Criterion
Electromagnetic compatibility of multimedia equipment – Emission Requirements		EN55032:2015+A11:2020, Class B
Electromagnetic compatibility of multimedia equipment – Immunity requirements		EN55035:2017+A11:2020
ESD Electrostatic discharge immunity test	Contact: $\pm 4kV$	EN61000-4-2:2008, Criteria A IEC61000-4-2:2009, Criteria A
Radiated, radio-frequency, electromagnetic field immunity test	10V/m (80-1000MHz), 3V/m (1400-2000MHz), 1V/m (2000-2700MHz)	IEC/EN61000-4-3:2006 + A2:2010, Criteria A
Fast Transient and Burst Immunity ⁽¹¹⁾	L, N, PE, L-N, L-PE, N-PE, L-N-PE: $\pm 2kV$	IEC/EN61000-4-4:2012, Criteria A
Surge Immunity ⁽¹¹⁾	L-N: $\pm 2kV$ L-PE, N-PE: $\pm 4kV$	IEC/EN61000-4-5:2014 + A1:2017, Criteria A
Immunity to conducted disturbances, induced by radio-frequency fields	10Vrms (0.15-10MHz) 3-1Vrms (10-30MHz) 1Vrms (30-80MHz)	IEC61000-4-6:2013, Criteria A EN61000-4-6:2014, Criteria A
Power Magnetic Field Immunity	1A/m	IEC61000-4-8:2009, Criteria A EN61000-4-8:2010, Criteria A
Voltage Dip	100% (0.5P); 30%	EN61000-4-11:2004 + A1:2017, Criteria A
Voltage Interruptions	100%	EN61000-4-11:2004 + A1:2017, Criteria B
Limits of Harmonic Current Emissions	$P_{out} = 112W$	EN61000-3-2:2005+A1+A2:2009
Limits of Voltage Fluctuations & Flicker		EN61000-3-3:2013
Limitations on the amount of electromagnetic interference allowed from digital and electronic devices		FCC 47 CFR Part 15 Subpart B, Class B

Note11: Valid under floating load conditions and with earth referenced output as well

DIMENSION & PHYSICAL CHARACTERISTICS

Parameter	Type	Value
Materials	PCB	FR4, (UL94-V0)
	chassis	aluminum
Dimension (LxWxH)	"/OF"	147.0 x 81.5 x 38.0mm 5.7 x 3.2 x 1.5 inch
	"/ENC"	147.0 x 81.5 x 40.0mm 5.7 x 3.2 x 1.6 inch
Weight	"/OF"	311g typ. 0.68 lbs
	"/ENC"	348g typ. 0.76 lbs

RACM140E-K Series \diamond AC/DC Power Supply

140W (210W/10s) \diamond Input: 100V-240VAC

DIMENSION & PHYSICAL CHARACTERISTICS

Dimension Drawing "0F" version (mm)

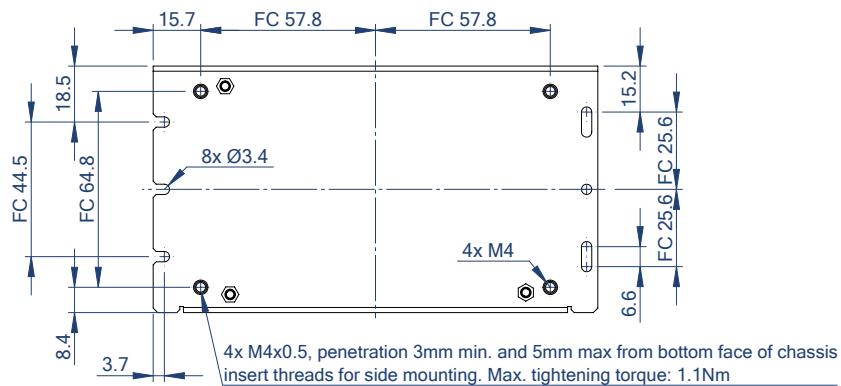
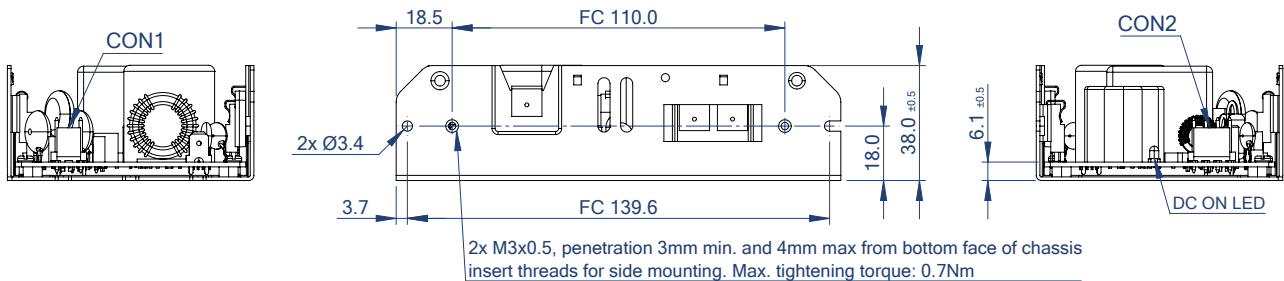
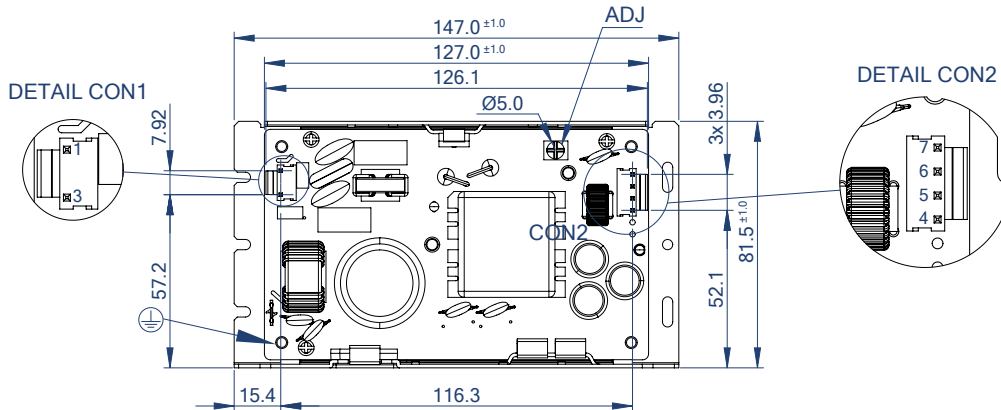
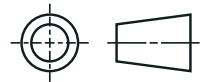

Connector Information

AC Input (CON1)

#	Function	Connector
1	VAC in (N)	3 Pins (Pin2 removed)
3	VAC in (L)	with 3.96mm pitch

DC Output (CON2)

#	Function	Connector
4, 5	+Vout	4 Pins
6, 7	-Vout	with 3.96mm pitch

FC= Fixing centers

Note12: Every indicated fixation points can be used for PE connections

Compatible Connector

Housing	Crimp Terminal
Molex 41695 Series or equivalent	Molex 2478 Series or equivalent

Tolerance: xx.x= ±0.5mm
xx.xx= ±0.25mm

RACM140E-K Series \diamond AC/DC Power Supply

140W (210W/10s) \diamond Input: 100V-240VAC

DIMENSION & PHYSICAL CHARACTERISTICS

Dimension Drawing "/ENC" version (mm)

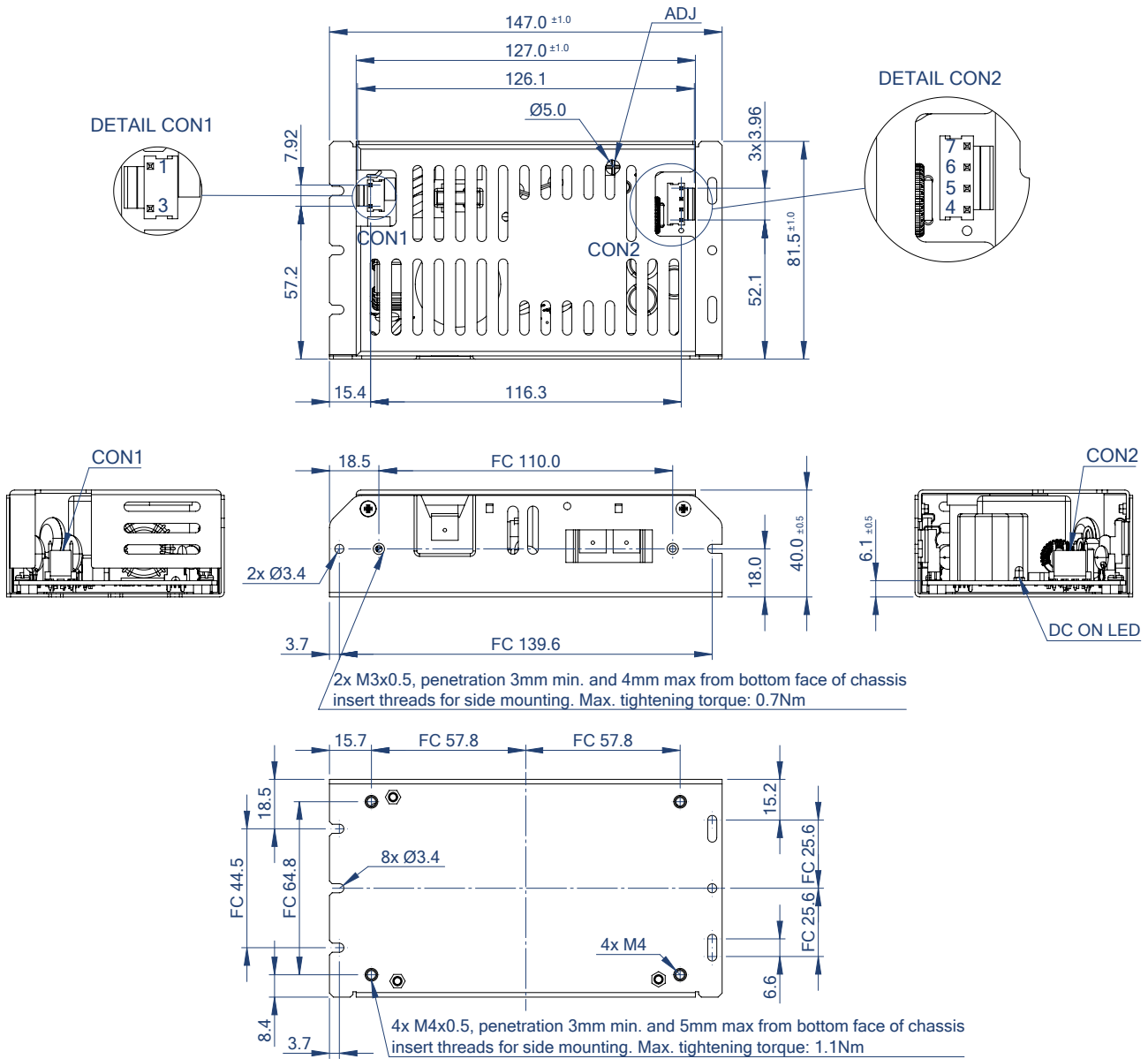
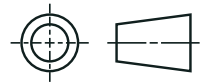

Connector Information

AC Input (CON1)

#	Function	Connector
1	VAC in (N)	3 Pins (Pin2 removed)
3	VAC in (L)	with 3.96mm pitch

DC Output (CON2)

#	Function	Connector
4, 5	+Vout	4 Pins
6, 7	-Vout	with 3.96mm pitch

FC= Fixing centers

Note12: Every indicated fixation points can be used for PE connections

Compatible Connector

Housing	Crimp Terminal
Molex 41695 Series or equivalent	Molex 2478 Series or equivalent

Tolerance: xx.x= ±0.5mm
xx.xx= ±0.25mm

RACM140E-K Series \diamond AC/DC Power Supply

140W (210W/10s) \diamond Input: 100V-240VAC

DIMENSION & PHYSICAL CHARACTERISTICS

Dimension Drawing "/ENC" version (mm)

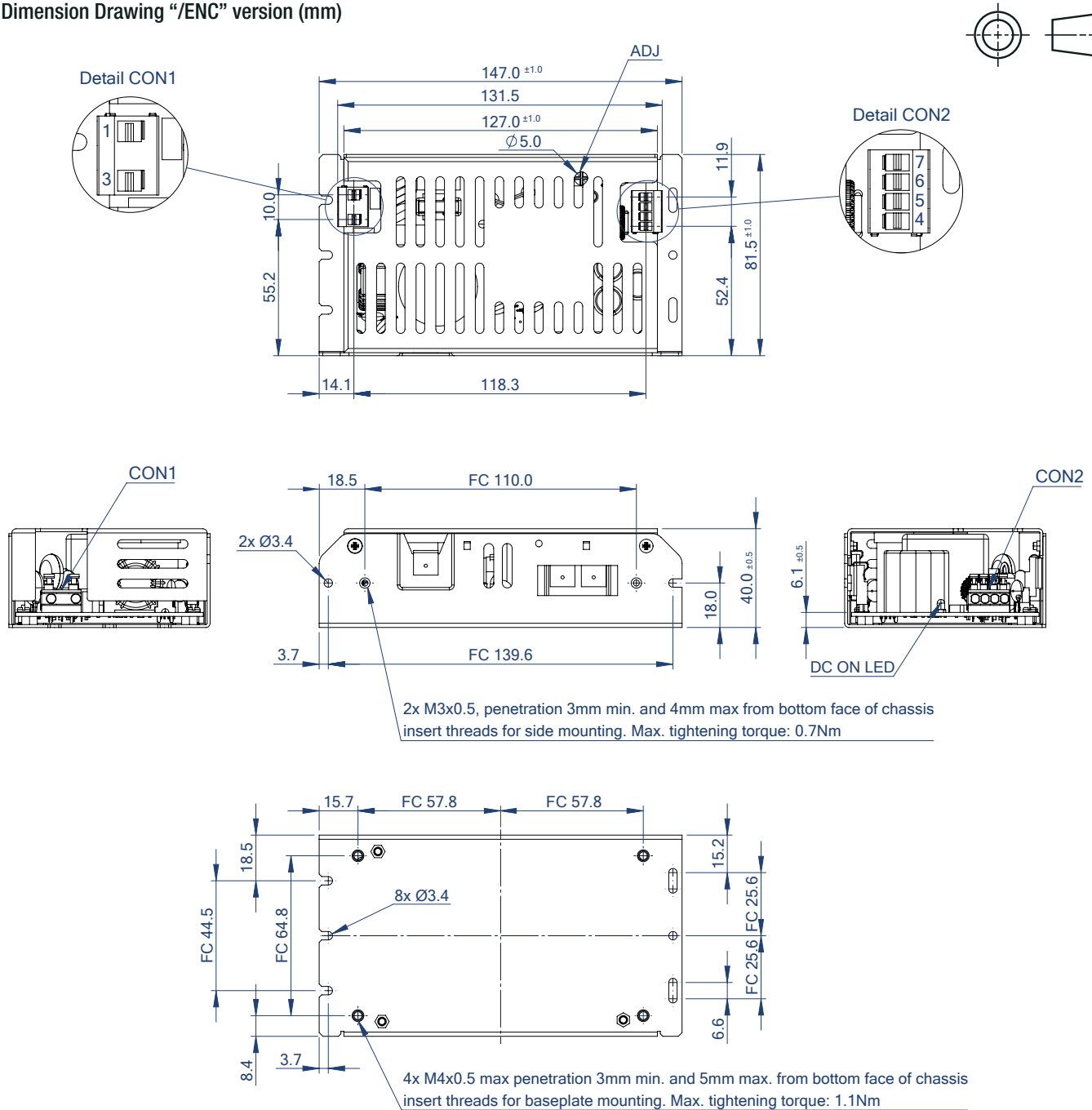

Push-in Terminal Information

AC Input (CON1)

#	Function	Connector
1	VAC in (N)	Solid: 0.5-2.5mm ²
3	VAC in (L)	Flexible: 0.5-1.5mm ²
		Flexible with ferrule: 0.5-1.0mm ²

Note12: Every indicated fixation points can be used for PE connections

DC Output (CON2)

#	Function	Connector
4, 5	+Vout	Solid: 0.5-1.5mm ²
6, 7	-Vout	Flexible: 0.5-1.5mm ²
		Flexible with ferrule: 0.5-1.0mm ²

Stripping length: 10mm

FC= Fixing centers

Tolerance: xx.x= ±0.5mm
xx.xx= ±0.25mm

INSTALLATION & APPLICATION

Mounting Equipment

Baseplate Mounting

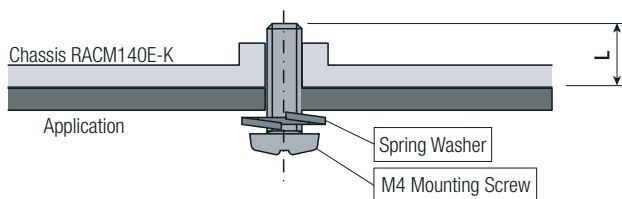

Recommended mounting tightening torque= 1.1Nm.
L= 3mm min. / 5mm max.

Side Mounting

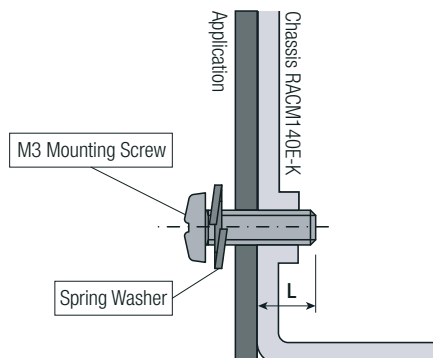

Recommended mounting tightening torque= 0.7Nm.
L= 3mm min. / 4mm max.

BLOCK DIAGRAM

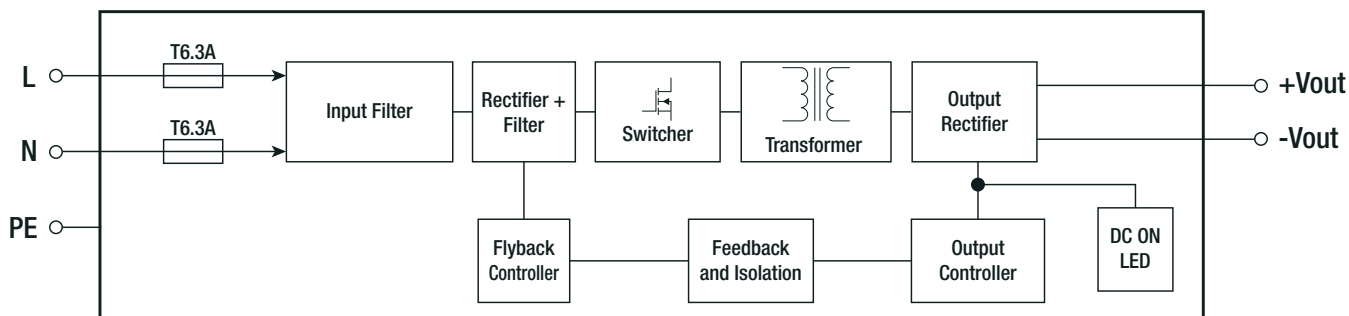

PACKAGING INFORMATION

Parameter	Type		Value
Packaging Dimension (LxWxH)	tray	open frame "/OF"	410.0 x 360.0 x 55.0mm
		enclosed "/ENC"	350.0 x 360.0 x 65.0mm
Packaging Quantity	open frame "/OF"		8pcs
	enclosed "/ENC"		6pcs
Storage Temperature Range			-40°C to +90°C
Storage Humidity	non-condensing		95% RH max.

The product information and specifications may be subject to changes even without prior written notice. The product has been designed for various applications; its suitability lies in the responsibility of each customer. The products are not authorized for use in safety-critical applications without RECOM's explicit written consent. A safety-critical application is an application where a failure may reasonably be expected to endanger or cause loss of life, inflict bodily harm or damage property. The applicant shall indemnify and hold harmless RECOM, its affiliated companies and its representatives against any damage claims in connection with the unauthorized use of RECOM products in such safety-critical applications.

X-ON Electronics

Largest Supplier of Electrical and Electronic Components

Click to view similar products for [Switching Power Supplies](#) category:

Click to view products by [RECOM POWER](#) manufacturer:

Other Similar products are found below :

[70841011](#) [73-551-0005](#) [73-551-0048](#) [73-558-0015I](#) [EVS57-5R3/A](#) [FAS-002](#) [AAD600S-4-OP](#) [MS924](#) [HWS50A-5/RA](#) [KD0204](#) [9021](#)
[LDIN100150](#) [FAP-001](#) [FP80](#) [FRV7000G](#) [22929](#) [PS3E-F12F](#) [CQM1IA121](#) [LDIN5075](#) [432703037161](#) [VI-LUL-IU](#) [LPM000-BBAR-08](#)
[LPM000-BBAR-07](#) [08-30466-1055G](#) [DMB-EWG](#) [CQM1IPS01](#) [SP-300-5](#) [MAP40-S233](#) [CQM1-IPS02](#) [73-551-0024I](#) [VI-MUL-ES](#) [22829](#)
[08-30466-0028G](#) [96PSR-A460WOTH-2](#) [G06-Q01](#) [GHA300F-12-SNF](#) [MP650-2K2K](#) [MTA040009A](#) [FSA150024A](#) [VI-RUR22-EWXX](#)
[HLS30ZE-NT8](#) [UT1404-7](#) [ERP-350-12](#) [S8FSG01512C](#) [S8FSG03012C](#) [XPFM201A+](#) [S8FS-G15015C](#) [S8FS-G05005C](#) [S8FS-G03015C](#) [08-](#)
[30466-020WG](#)