

## Features

- Universal AC input (85-264VAC)
- Long 7 year warranty
- Protections: SCP, OVP, OCP, OTP
- 100% full load burn-in test
- DC OK indicator LED with relay contacts
- Cooling by free air convection, 5000m operation
- UL, CSA & CE certified with CB report

## DIN Rail Series

## REDIN60

## 60 Watt DIN-Rail Power Supply



### Description

This DIN-rail mounted power supply uses high reliability components to give a long, trouble-free life. The power supply can be end mounted to save space or side mounted for use in low-profile cabinets. Relay contacts simplify DC OK monitoring and the units can deliver 80W start-up power. The REDIN series is fully certified for industrial use and carries a 7-year warranty.

### Selection Guide

Part Number	Input Voltage Range [VAC]	Output Voltage [VDC]	Output Trimming Voltage [VDC]	Rated Current [A]	Efficiency typ. [%]	Max. Capacitive Load [μF]
REDIN60-12	85-264	12	12-15	5.0	85	18800
REDIN60-24	85-264	24	24-28	2.5	86	4700



### Specifications (measured at Ta= 25°C, 230VAC, full load and after warm up)

BASIC CHARACTERISTICS				
Parameter	Condition	Min.	Typ.	Max.
Input Voltage Range	all operating conditions	85VAC		264VAC
max. Input Voltage	max. 1 second			300VAC 375VDC
Output Voltage Adjustment (Factory Setting) <sup>(1)</sup>	REDIN60-12 REDIN60-24		12-15VDC (12V±5%) 24-28VDC (24V±5%)	
Input Current	full load, 115VAC full load, 230VAC			1.8A 1.0A
Inrush Current	cold start at 25°C, 115VAC cold start at 25°C, 230VAC			40A 60A
No Load Power Consumption	standard (with Relay) /NR option (no Relay)			<1000mW <500mW
Start up time	cold start, 230VAC		500ms	1000ms
Rise time	cold start, 230VAC		20ms	
Hold-up time	full load, 115VAC full load, 230VAC		20ms 50ms	
Input Frequency Range		47Hz		63Hz
Operating Frequency Range			65kHz	
Output Ripple and Noise <sup>(2)</sup>	REDIN60-12 REDIN60-24		60mVp-p 75mVp-p	
Over Load Capability	all operating conditions			140% for 5 seconds max.

#### Notes:

Note1: For more details refer to "Vadj. Derating" graph

Note2: Ripple and Noise are measured at 20MHz bandwidth by using a 12" twisted pair-wire terminated with 0.1μF & 47μF parallel capacitor

continued on next page



- CB-Report UL60950-1 certified
- IEC/EN60950-1 certified
- CSA C22.2 No. 60950-1-07 certified
- UL508 certified
- CAN/CSA-C22.2 No. 107.1-01 certified
- EN55024 certified
- EN55032 certified

**SEARCHING FOR ALTERNATIVES?**

**Contact RECOM**

<https://recom-power.com/contact.html>

**Specifications** (measured at Ta= 25°C, 230VAC, full load and after warm up)

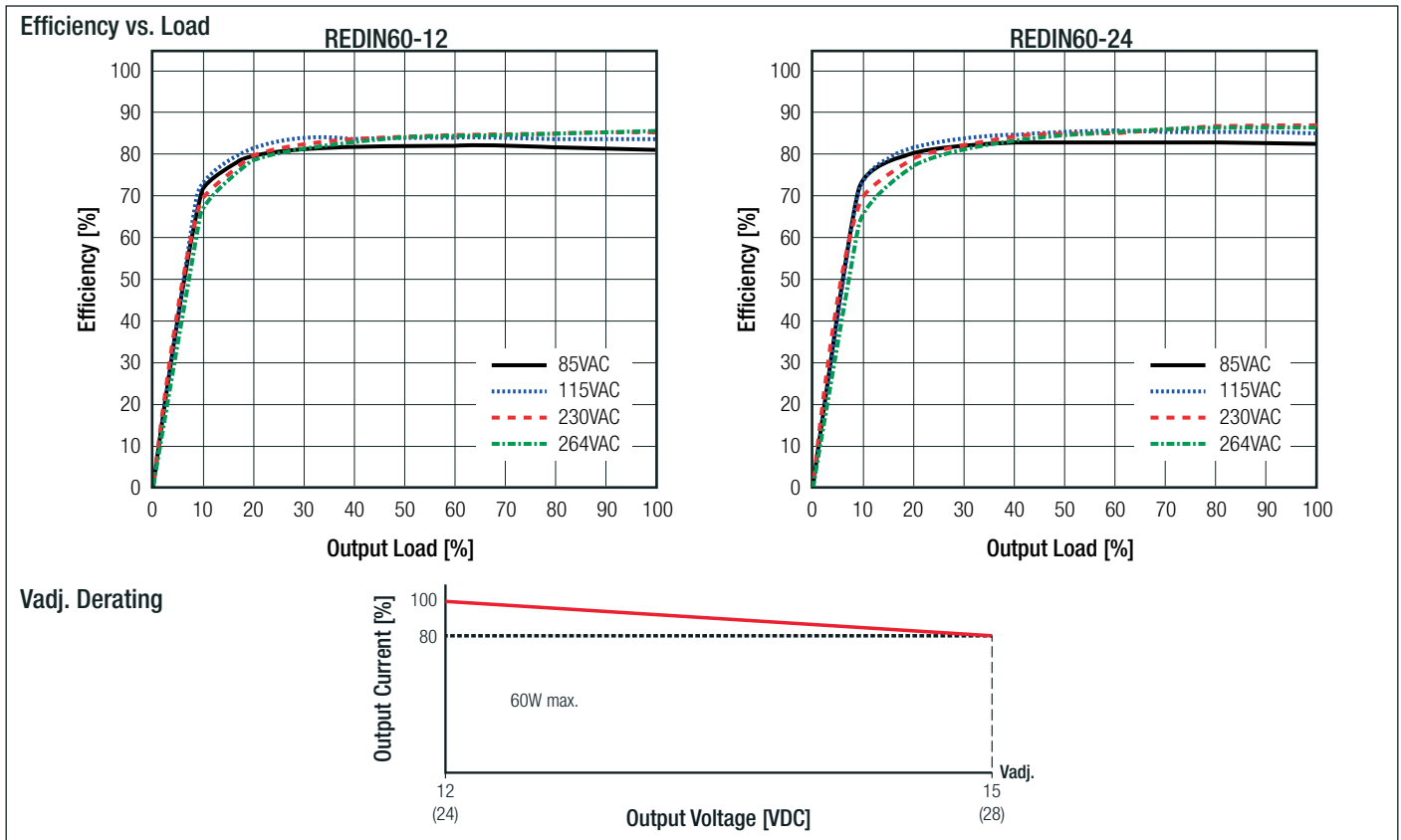

REGULATION		
Parameter	Condition	Value
Line Regulation		±0.1% typ. / ±1% max.
Load Regulation		0.1% typ. / 1% max.
Transient Response <sup>(3)</sup>	REDIN60-12 (step load change: 2.5A - 5.0A) REDIN60-24 (step load change: 1.25A - 2.5A)	±5% typ. ±5% typ.
Dwell Time		100Hz & 1kHz 50% duty
Slew Rate		0.5A / μs
<b>Notes:</b>		
Note3: Transient Response + E-CAP loading 3300μF. Other specs with resistive load only		

PROTECTION		
Parameter	Condition	Value
Input Fuse		T2.5A, slow blow type
Short Circuit Protection (SCP)		auto-recovery after fault condition, Hiccup Mode
Over Voltage Protection (OVP)	REDIN60-12 REDIN60-24	18VDC max., shut-down latch-off o/p voltage, re-power on to recover 35VDC max., shut-down latch-off o/p voltage, re-power on to recover
Over Voltage Category		OVCII
Over Current Protection (OCP)		150% typ., auto-recovery after fault condition is removed
Over Temperature Protection (OTP)	detect on inside ambient	105°C±5%, shut-down latch-off o/p voltage, re-power on to recover
Isolation Voltage	tested for 1 minute	I/P to O/P: 3.75kVAC I/P to FG: 1.88kVAC O/P to FG: 0.5kVAC
Isolation Resistance	500VDC, 70% RH, I/P to O/P; I/P to FG; O/P to FG	100MΩ min.
Leakage Current	240VAC	>1mA
Power OK LED	Relay Contacts LED/Relay	1A, 30VDC / 120VAC ON if Vout = 11-16V (12V) / 22-30V (24V)

**Specifications** (measured at Ta= 25°C, 230VAC, full load and after warm up)

**ENVIRONMENTAL**

Parameter	Condition	Value
Operating Temperature Range	with derating	-20°C to +70°C (see graph)
Operating Humidity	non-condensing	20% - 90%RH
Vibration		10-500Hz 2G, 60min.
Shock	3 times each axis	10G / 11ms, along X, Y and Z axis
Altitude	see derating graph	5000m
MTBF (+25°C)	according to MIL-HDBK-217F, 115VAC, 60Hz, 75% load	200 x 10 <sup>3</sup> hours
Design Lifetime (+40°C)		87.6 x 10 <sup>3</sup> hours

**Derating Graph**

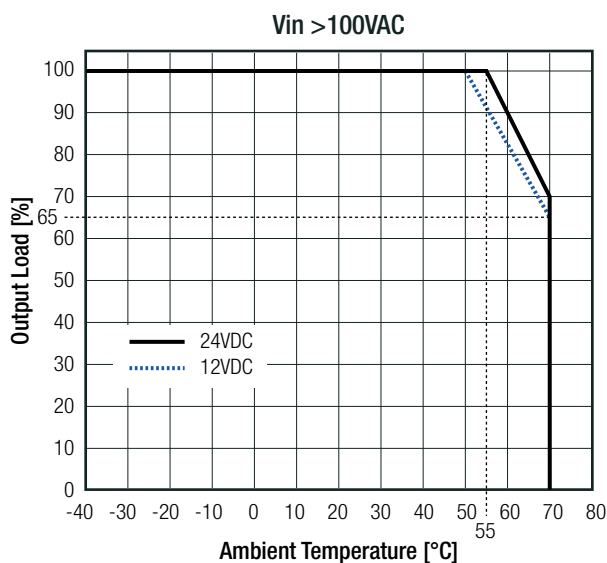
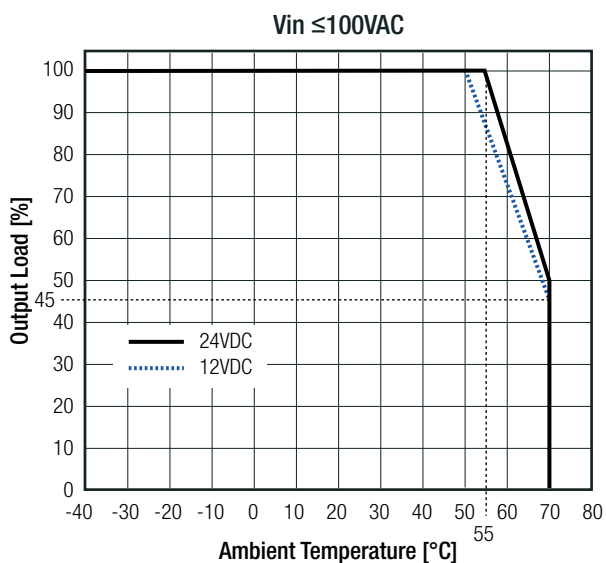

**Typical Characteristics**

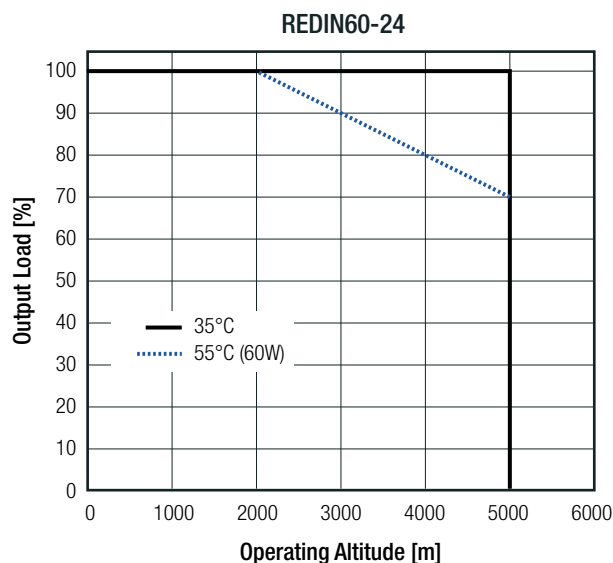
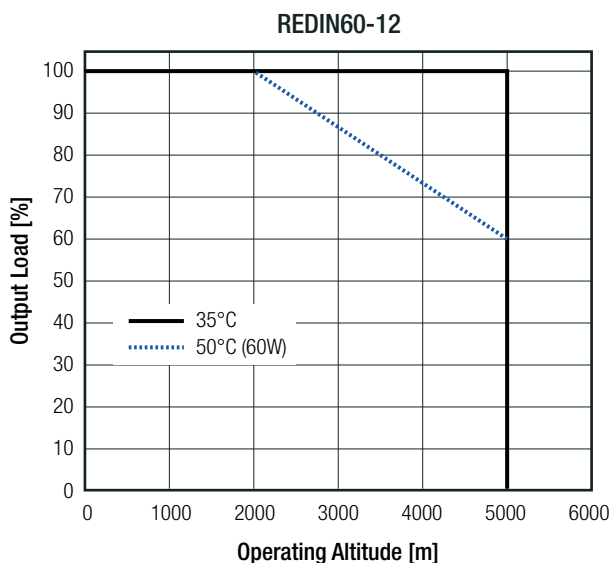

**Specifications** (measured at Ta= 25°C, 230VAC, full load and after warm up)

SAFETY AND CERTIFICATIONS		
Certificate Type (Safety)	Report / File Number	Standard
Information Technology Equipment - General Requirments for Safety	E224736-A23	UL60950-1 2nd Edition 2011 CAN/CSA-C22.2 No. 60950-1-07 2nd Edition 2011
Industrial Control Equipment	E470721	CAN/CSA-C22.2 No. 107.1-01, 3rd Edition 2011 UL508, 17th Edition 2013
Information Technology Equipment - General Requirments for Safety	E224736-A23	EN60950-1:2006 + A2:2013 IEC60950-1:2005 2nd Edition + A1:2009
EAC	RU-AT.37.02367	TP TC 004/2011
RoHS2		RoHS 2011/65/EU

EMC Compliance	Report / Condition	Standard / Criterion
Electromagnetic compatibility of multimedia equipment – Emission Requirements		EN55032:2015
Information technology equipment - Immunity characteristics - Limits and methods of measurement		EN55024:2010 + A1:2015
ESD Electrostatic discharge immunity test	Air +/-2, 4, 8kV, Contact +/-2, 4kV	IEC61000-4-2:2008; Criteria A
Radiated, radio-frequency, electromagnetic field immunity test	3V/m	IEC61000-4-3:2006 + A1:2007 + A2:2010; Criteria A
Fast Transient and Burst Immunity	AC Power Port: +/-1.0kV	IEC61000-4-4:2012; Criteria A
Surge Immunity	AC Power Port: L-N +/-0.5, 1, 2kV L-PE, N-PE +/-0.5, 1, 2, 4kV	IEC61000-4-5:2014; Criteria A
Immunity to conducted disturbances, induced by radio-frequency fields	AC Power Port 3V	IEC61000-4-6:2013; Criteria A
Power Magnetic Field Immunity	50Hz, 1A/m	IEC61000-4-8:2009; Criteria A
Voltage Dips and Interruptions	Voltage Dips >95% Voltage Dips 30% Voltage Interruptions > 95%	IEC61000-4-11:2004; Criteria A IEC61000-4-11:2004; Criteria A IEC61000-4-11:2004; Criteria B
Limits of Harmonic Current Emissions		EN61000-3-2:2014, Class A
Limits of Voltage Fluctuations & Flicker		EN61000-3-3:2013
Limitations on the amount of electromagnetic intererence allowed from digital and electronic devices		47 CFR FCC Part 15 Subpart B 2010-01-07, Class B

**DIMENSION and PHYSICAL CHARACTERISTICS**

Parameter	Type	Value
Material	case	plastic, (UL94V-0)
Dimension (WxHxD)		45.1 x 92.0 x 101.2mm
Weight		332g

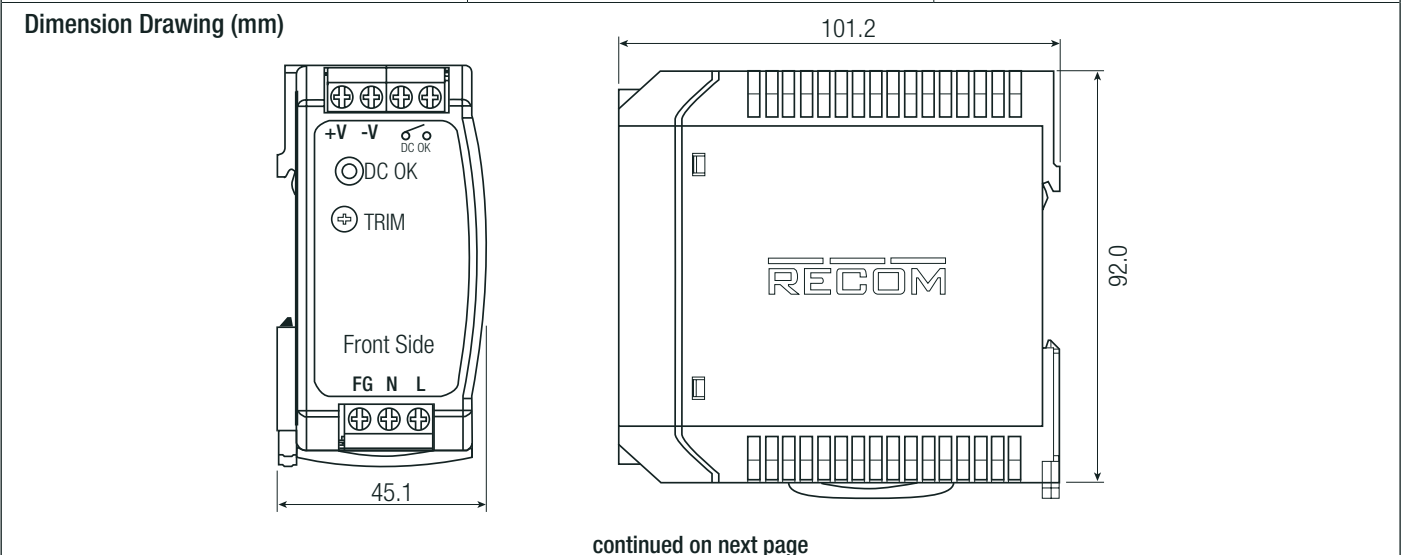

continued on next page

Specifications (measured at Ta= 25°C, 230VAC, full load and after warm up)

Dimension Drawing (mm)

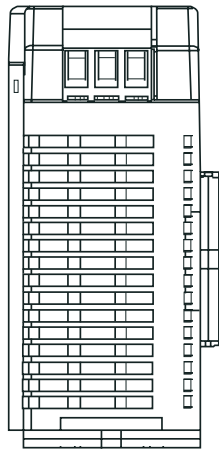

DIN-RAIL mounting bracket  
(75mm) included

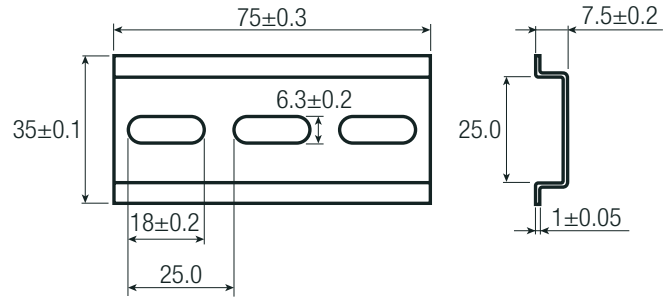

INSTALLATION

END MOUNTING

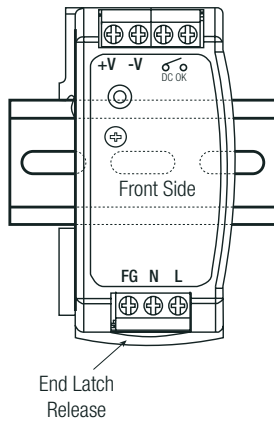

SIDE MOUNTING

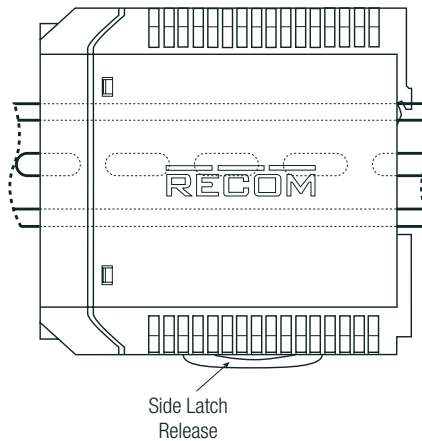

Tolerance: ±0.5mm

Mounting Instruction

Mounting

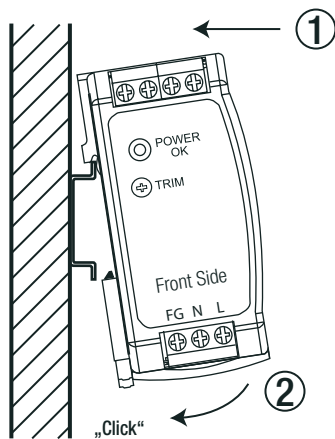

Releasing

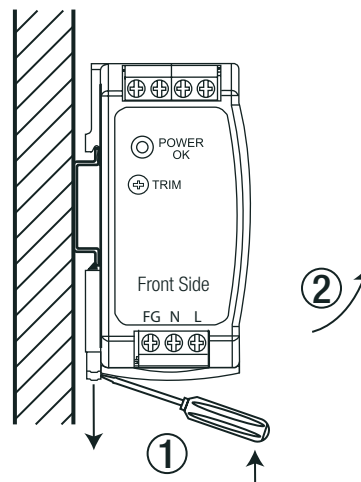

continued on next page

Specifications (measured at Ta= 25°C, 230VAC, full load and after warm up)

**Mounting Multiple Power Supplies**

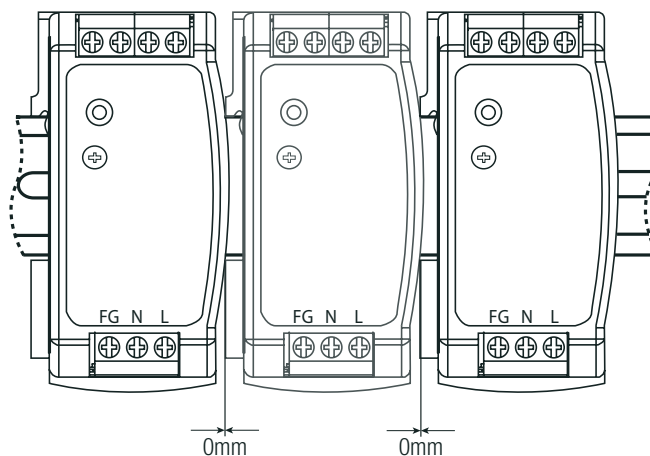

no spacers between  
supplies required

**BLOCK DIAGRAM**

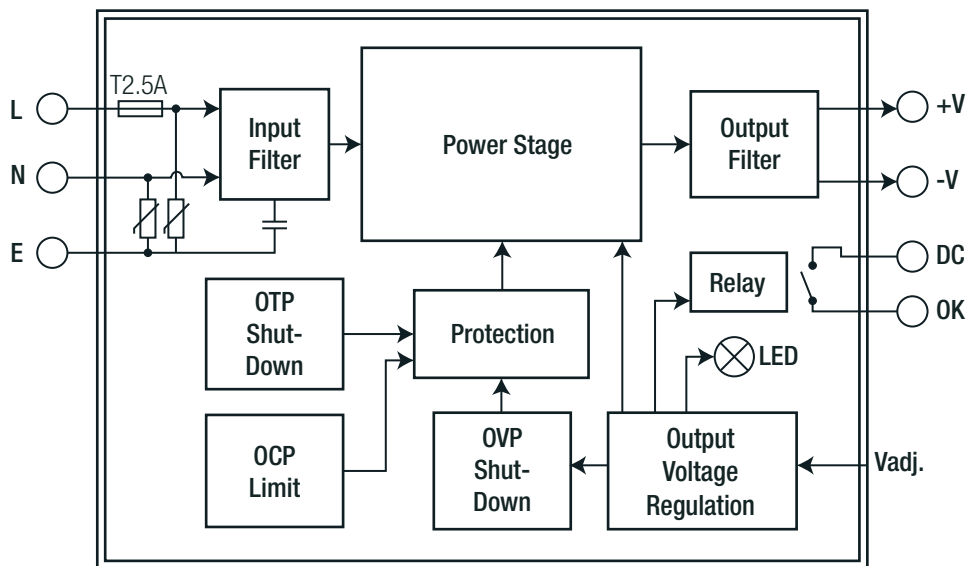

**PACKAGING INFORMATION**

Parameter	Type	Value
Packaging Dimension (LxWxH)	cardboard box	116.0 x 97.0 x 54.0mm
Packaging Quantity		1pcs
Storage Temperature Range		-30°C to +85°C
Storage Humidity		10% - 90% RH

The product information and specifications may be subject to changes even without prior written notice. The product has been designed for various applications; its suitability lies in the responsibility of each customer. The products are not authorized for use in safety-critical applications without RECOM's explicit written consent. A safety-critical application is an application where a failure may reasonably be expected to endanger or cause loss of life, inflict bodily harm or damage property. The applicant shall indemnify and hold harmless RECOM, its affiliated companies and its representatives against any damage claims in connection with the unauthorized use of RECOM products in such safety-critical applications.

## X-ON Electronics

Largest Supplier of Electrical and Electronic Components

*Click to view similar products for [DIN Rail Power Supplies](#) category:*

*Click to view products by [RECOM POWER](#) manufacturer:*

Other Similar products are found below :

[PS-S6024](#) [DVP01PU-S](#) [DVP06AD-S](#) [DVP06XA-S](#) [DVDPNET-SL](#) [DVPDT01-S](#) [DVPPS01](#) [PS-6012](#) [PS9Z-5R1G](#) [PS-C24024](#)  
[DVP08ST11N](#) [DVPACAB530](#) [DVPCOPM-SL](#) [DVPEN01-SL](#) [DVPPF01-S](#) [ADNB008-48-1PM-C](#) [ADNB017-24-1PM-C](#) [ADNB040-24-1PM-C](#) [ADNB034-12-1PM-C](#) [SS14011524](#) [PS-UPS40](#) [PSC-6024](#) [PSD-A60W12](#) [96PS-A120WDIN](#) [PSD-A60W48](#) [PSD-A40W12](#) [PSD-A40W24](#) [SMP21-L20-DC24V-5A](#) [PSD-A40W48](#) [S8T-DCBU-02](#) [PS-S4024](#) [NTPS-24-1.3](#) [ZI-20](#) [PST-96024](#) [S82YVSC4P](#) [PS-S4005](#) [PS-10024](#) [PS-S10024](#) [PS-C12024](#) [PSP-480S24](#) [PS-C48024](#) [PSC-2024](#) [PSC-4012](#) [PSC-4048](#) [PSC-9615](#) [PSC-15124](#) [PSC-15148](#) [PSC-24148](#) [PSC-48148](#) [TRIO-PS-2G/1AC/12DC/5/C2LP](#)