

RPL-10 Series / Power Module

10Amp / 4-16VDC / 29 Pad LGA-M Package

FEATURES

- High power density (10A in 7x7x4.4mm)
- Operating temperature of -40°C to +90°C at full load
- High efficiency 94%
- Wide 4-16VDC input voltage
- SCP, OCP, and UVLO protection
- Programmable 0.6-5.5V output
- Selectable operating frequency (600kHz - 1MHz)
- Constant on-time for fast transient load response
- Pulse skipping for optimal light load performance
- 3 year warranty



Dimensions (LxWxH): 7.0 x 7.0 x 4.4mm (0.276 x 0.276 x 0.173inch)
0.1g (0.0002 lbs)

APPLICATIONS



SAFETY & EMC



DESCRIPTION

The RPL-10 is a 10A buck converter with integrated inductor in a compact 7mm x 7mm x 4.4mm thermally-enhanced LGA package. The input range is from 4.0 to 16VDC, allowing both 5V and 12V supply rails to be used. The output voltage can be set with two resistors in the range from 0.6V up to 5.5V. The output is fully protected against continuous short-circuit, overload, under-voltage or over-temperature faults. A PG output and EN input allow easy power sequencing. Its high output current capability, small size, light load pulse skipping and fast transient regulation make the RPL-10 ideal for FPGAs, imaging systems, distributed power architectures, portable equipment in telecom as well as industrial applications.

SELECTION GUIDE

Part Number	Input Voltage Range [VDC]	Output Voltage Range [VDC]	Output Current max. [A]	Efficiency ⁽¹⁾ typ. [%]
RPL-10	4 - 16	0.6 - 5.5	10	94

Note1: Efficiency is tested at $V_{IN}= 12VDC$, $V_{OUT}= 5VDC$ full load at +25°C ambient

MODEL NUMBERING

RPL-10-
 Output Current _____ Packaging ⁽²⁾

Note2: Add suffix "-T" for tray packaging
 Add suffix "-CT" for bag packaging (refer to „Packaging Information“)

RPL-10 Series / Power Module

10Amp / 4-16VDC / 29 Pad LGA-M Package

ABSOLUTE MAXIMUM RATINGS

Parameter	Symbol	Condition	Min.	Typ.	Max.
Absolute Maximum Voltage	V_{IN}		-0.3VDC		18VDC
	V_{SW}		-0.3VDC		0.3VDC
	V_{CC}				4.5VDC
	others		-0.3VDC		4.3VDC
Maximum Continuous Power Losses ⁽³⁾		$T_{AMB} = +25^{\circ}C$			9W
Junction Temperature	T_J				+170°C
Lead Temperature					+260°C

Note3: Exceeding maximum allowable power dissipation causes device to enter thermal shutdown which protects device from permanent damage.

Note4: Stressed beyond those listed under absolute maximum ratings can cause permanent damage to the device.

BASIC CHARACTERISTICS (measured @ $T_{AMB} = 25^{\circ}C$, nom. V_{IN} , full load and after warm-up unless otherwise stated)

Parameter	Symbol	Condition	Min.	Typ.	Max.
Input Voltage Range	V_{IN}	refer to „Safe Operating Area“	4VDC		16VDC
Vin-Vsw			-0.3VDC		0.3VDC
Vsw			-0.3VDC		0.3VDC
Under Voltage Lockout UVLO		rising, $V_{CC} = 3.3VDC$	2.1VDC	2.4VDC	2.7VDC
		falling, $V_{CC} = 3.3VDC$	1.55VDC	1.85VDC	2.15VDC
Quiescent Current	I_Q	$V_{CTRL} = 2VDC, V_{FB} = 0.62VDC$		650µA	850µA
Output Voltage Range	V_{OUT}	refer to „Safe Operating Area“	0.6VDC		5.5VDC
Standby Current	I_S	$V_{CTRL} = 0VDC$		10µA	
Feedback Voltage	V_{FB}	$T_J = -40^{\circ}C$ to $125^{\circ}C$	594mV	600mV	606mV
		$T_J = 0^{\circ}C$ to $70^{\circ}C$	597mV	600mV	603mV
Minimum On Time		$V_{FB} = 500mV$			50ns
Minimum Off Time		$V_{FB} = 500mV$			180ns
Soft Start		$C_{TRACK} = 100nF, T_J = 25^{\circ}C$		1.6ms	

Safe Operating Area

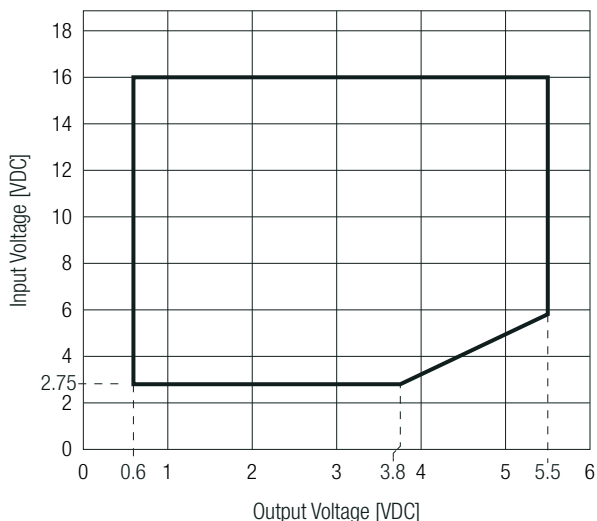

CTRL OPERATING CONDITIONS

Parameter	Symbol	Condition	Min.	Typ.	Max.
ON/OFF CTRL		DC-DC ON			$V_{CTRL} > 1.6VDC$
		DC-DC OFF			$V_{CTRL} < 1.3VDC$
CTRL Voltage				3.6VDC	4.3VDC
CTRL Rising Threshold	V_{CTRL_RISING}		1.19VDC	1.22VDC	1.25VDC
CTRL Hysteresis Threshold			160mV	200mV	280mV
CTRL Input Current	I_{CTRL}				50µA

CTRL OPERATING CONDITIONS

Typical Application

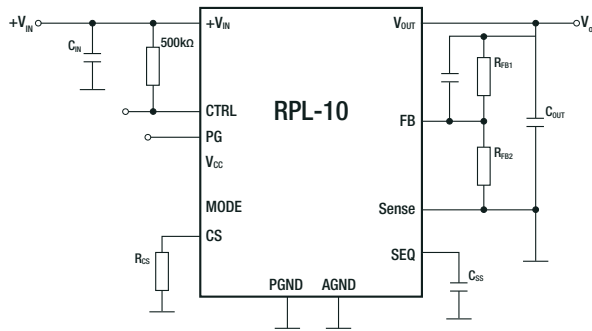

POWER GOOD OPERATING CONDITIONS

Parameter	Symbol	Condition	Min.	Typ.	Max.
high Threshold	PG _{HIGH_RISE}	Pull FB from low to high	89.5% of V _{REF}	92.5% of V _{REF}	95.5% of V _{REF}
	PG _{HIGH_FALL}	Pull FB from high to low	92% of V _{REF}	101% of V _{REF}	108% of V _{REF}
low Threshold	PG _{LOW_RISE}	Pull FB from low to high	113% of V _{REF}	116% of V _{REF}	119% of V _{REF}
	PG _{LOW_FALL}	Pull FB from high to low	77% of V _{REF}	80% of V _{REF}	83% of V _{REF}
Rise Delay		T _J = 25°C		0.9ms	
Sink Current Capability	V _{PG}	I _{PG} = 10mA			0.4VDC
Leakage Current	I _{PG_LEAK}	V _{PG} = 3.3VDC			3μA
Low Output Voltage	V _{OUT_LOW_100}	V _{IN} = 0VDC, pull PG to 3.3VDC with 100kΩ resistor		650mV	850mV
	V _{OUT_LOW_10}	V _{IN} = 0VDC, pull PG to 3.3VDC with 10kΩ resistor		800mV	1000mV

Note5: The PG pin is an open-drain signal. A 100kΩ pull-up resistor connected to V_{CC} indicates high if V_{OUT} is within regulation.

SWITCHING CHARACTERISTICS

Parameter	Symbol	Condition	Min.	Typ.	Max.
Switching Frequency	f _{sw}	mode = V _{CC}	480kHz	600kHz	720kHz
		mode = open	680kHz	800kHz	920kHz
		mode = 243kΩ to GND	850kHz	1000kHz	1150kHz

VCC CONDITIONS

Parameter	Symbol	Condition	Min.	Typ.	Max.
VCC Regulator			2.88VDC	3VDC	3.12VDC
VCC Load Regulation		I _{CC} = 25mA		0.5%	
VCC UVLO Rising Threshold			2.65VDC	2.81VDC	2.95VDC
VCC UVLO Falling Threshold			2.35VDC	2.5VDC	2.65VDC
External VCC bias			3.12VDC		3.6VDC

OUTPUT VOLTAGE SETTING

The external resistor divider is used to set the output voltage. First, choose a value for R_{FB2}. R_{FB2} should be chosen reasonably, a small R_{FB2} will lead to considerable quiescent current loss while too large R_{FB2} makes the FB noise sensitive. It is recommended to choose a value between 100kΩ-500kΩ for R_{FB2}. Typically, set the current through R_{FB2} between 1-5μA will make a good balance between system stability and also the no load loss. Then R_{FB1} is determined as followed. The values for trim resistors shown in trim tables below are according to standard E96 values; therefore, the specified voltage may slightly vary.

Feedback Network

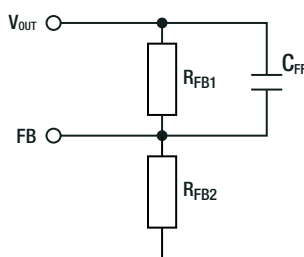

Calculation:

$$R_{FB2} = \frac{V_{ref}}{(V_{OUT} - V_{ref})} \times R_{FB1}$$

Practical example with V_{OUT} = 1.8VDC

$$R_{FB2} = \frac{0.6V}{(1.8V - 0.6V)} \times 2k\Omega = 1k\Omega$$

Table below lists recommended resistor values for common V_{OUT}:

V _{OUTset} [VDC]	C _{FF} [nF]	R _{FB1} [Ω]	R _{FB2} [Ω]
1	4.7	2k	3k
1.2			2k
1.8		1k	
3.3		10k2	2k26
5.5		7k5	1k02

RPL-10 Series / Power Module

10Amp / 4-16VDC / 29 Pad LGA-M Package



THERMAL OPERATING CONDITIONS

Parameter	Symbol	Condition	Min.	Typ.	Max.
Operating Junction Temperature	T_J	refer to „Thermal Derating“	-40°C		+125°C
Thermal Resistance ⁽⁶⁾	$R_{th,JA}$	junction to ambient		16.2K/W	
	$R_{th,JC}$	junction to case		5.1K/W	

Note6: Test PCB= 6.4 x 6.4cm double sided PCB with 20oz copper, natural convection

ENVIRONMENTAL

Parameter	Condition	Value
Moisture Sensitivity Level (MSL)		Level 3

PROTECTIONS

Parameter	Condition	Value	
Short Circuit Protection (SCP)		hiccup, auto recovery	
Over Current Protection (OCP)		hiccup, auto recovery	
Output Overvoltage Protection Rising	% of V_{REF}	113% min. - 119% max.	
Thermal Shutdown	restart after cooldown	junction temperature	160°C typ.
		hysteresis	30°C typ.

TYPICAL PERFORMANCE CHARACTERISTICS

1.2Vout

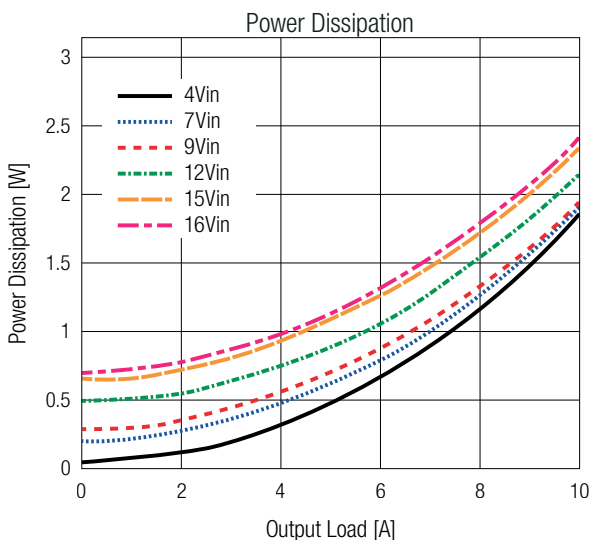
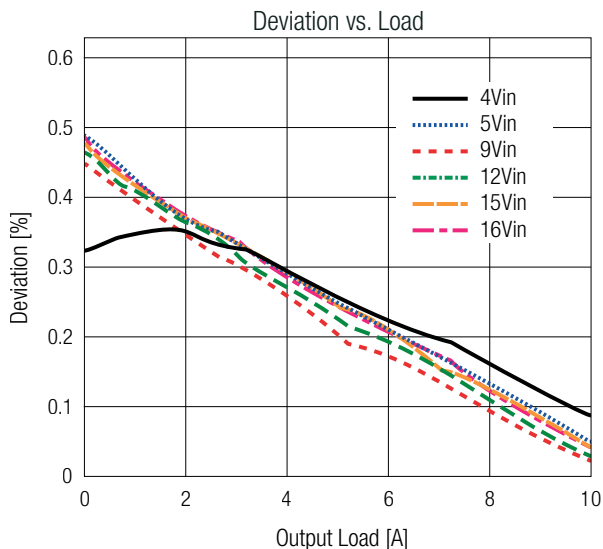
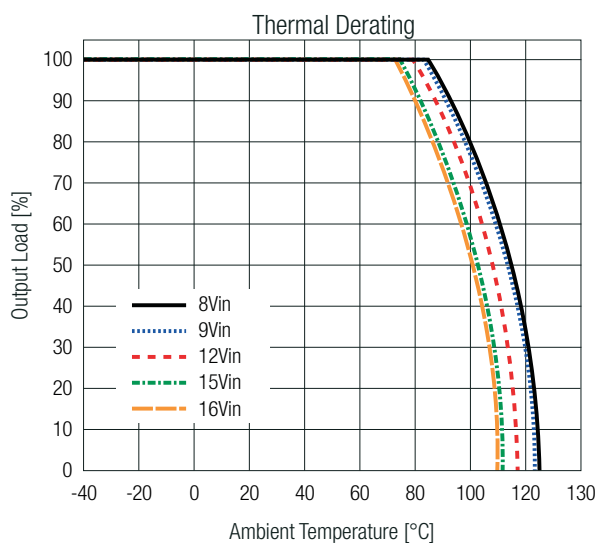
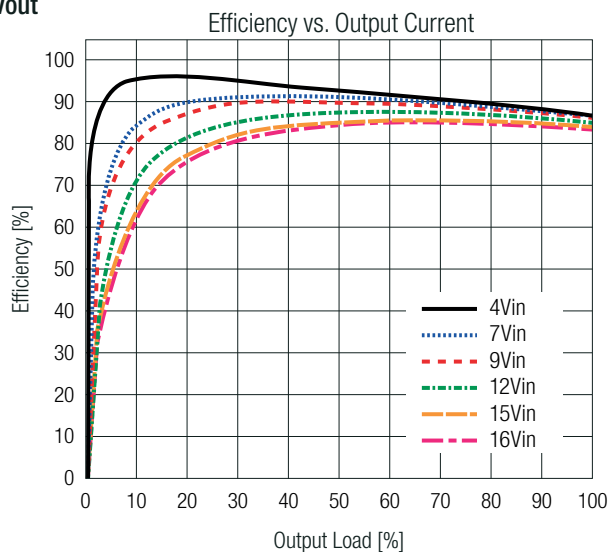

TYPICAL PERFORMANCE CHARACTERISTICS

5Vout

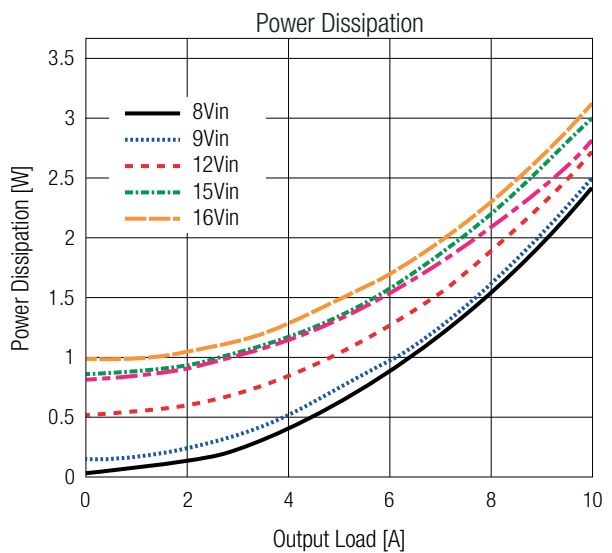
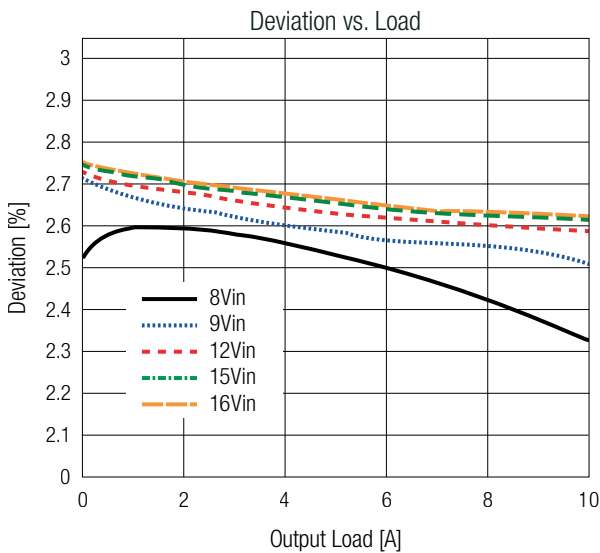
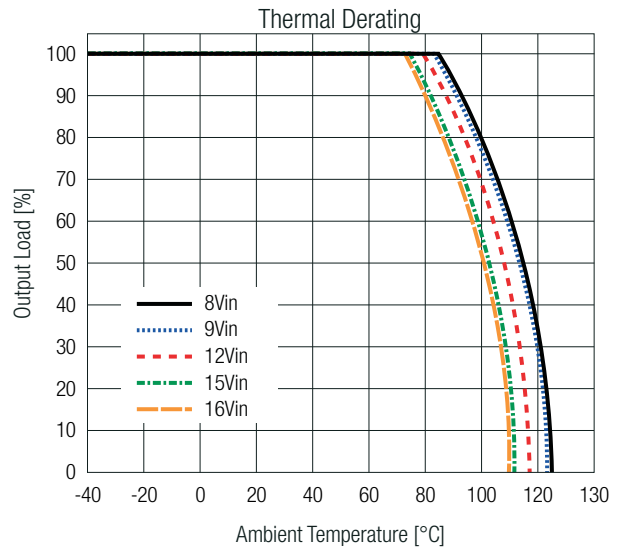
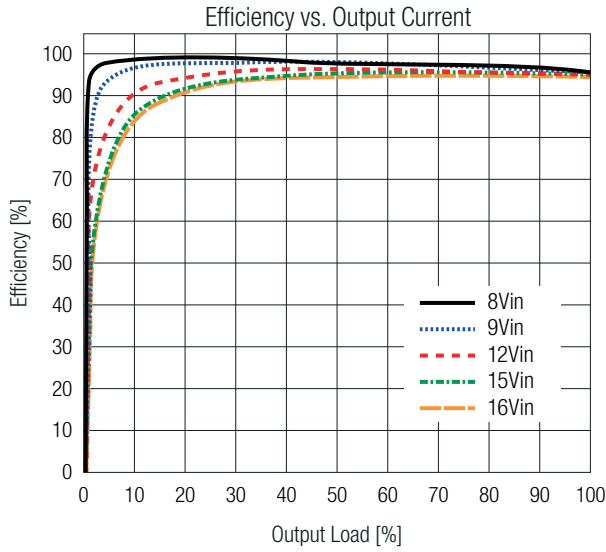

SAFETY & CERTIFICATIONS

Certificate Type (Safety)	Report Number	Standard
RoHS2		RoHS 2011/65EU + AM2015/863

DIMENSION & PHYSICAL CHARACTERISTICS

Parameter	Type	Value
Material	case	plastic
Dimension (LxWxH)		7.0 x 7.0 x 4.4mm 0.276 x 0.276 x 0.173inch
Weight		0.1g typ. 0.0002 lbs

DIMENSION & PHYSICAL CHARACTERISTICS

Dimension Drawing (mm)

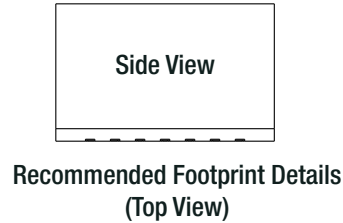
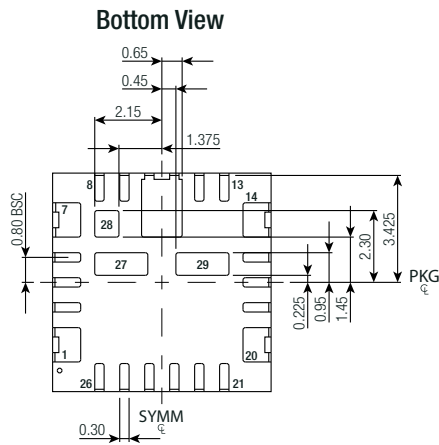
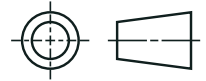
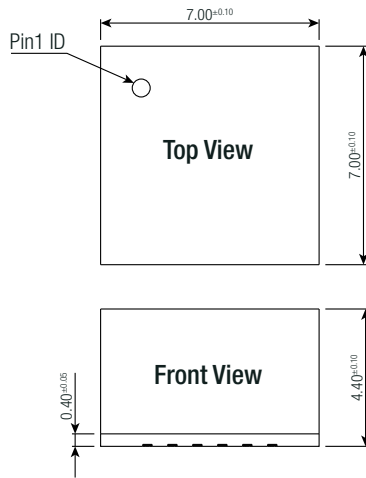

Tolerances:
 x.x= ±0.1mm
 x.xx= ±0.05mm

Pad Information

Pad #	Function	Description
1, 2, 6, 7	V _{OUT}	Output Voltage
3	CTRL/UVLO	CTRL pin. Do not float.
4	PG	Power good output.
5, 8, 9, 27, 28	+V _{IN}	Input supply voltage. Connect using wide PCB traces.
10, 11, 12	PGND	System ground. Use wide PCB traces.
13	V _{CC}	Internal 3V low-dropout (LDO) output.
14, 15, 16, 19, 20, 29	SW	Connect to floating copper plane for improved thermal performance. Thermal pad must be floating.
17	NC	Do not connect.
18, 21	AGND	Analog ground. AGND pin is the control circuit reference point.
22	CS	Current limit setpoint.
23	MODE	Operation mode selection. Configure the MODE pin to the operating switching frequency (f _{sw}).
24	SEQ	External tracking voltage/soft start capacitor input. V _{OUT} tracks the SEQ pin input signal. In the range of 0.6-1.4V. Decouple with 27nF MLCC capacitor between this pin and Sense, or use a larger value to increase the soft-start time.
25	Sense	Connect to negative voltage sense point or to AGND if not used.
26	FB	FB input. Used to set output voltage between 0.6 and 5.5V.

RPL-10 Series / Power Module

10Amp / 4-16VDC / 29 Pad LGA-M Package



PACKAGING INFORMATION

Parameter	Type	Value
Packaging Dimension (LxWxH)	Suffix -T: tray	392 x 160 x 98mm
		15.43 x 6.3 x 3.86inch
	Suffix -CT: moisture barrier bag	100 x 100 x 30mm
Packaging Quantity	Suffix -T: tray	260pcs
	Suffix -CT: moisture barrier bag	10pcs
Storage Temperature Range		-65°C to +150°C
Storage Humidity	non-condensing	60% RH max.

The product information and specifications may be subject to changes even without prior written notice. The product has been designed for various applications; its suitability lies in the responsibility of each customer. The products are not authorized for use in safety-critical applications without RECOM's explicit written consent. A safety-critical application is an application where a failure may reasonably be expected to endanger or cause loss of life, inflict bodily harm or damage property. The applicant shall indemnify and hold harmless RECOM, its affiliated companies and its representatives against any damage claims in connection with the unauthorized use of RECOM products in such safety-critical applications.

X-ON Electronics

Largest Supplier of Electrical and Electronic Components

Click to view similar products for [Switching Voltage Regulators](#) category:

Click to view products by [RECOM POWER](#) manufacturer:

Other Similar products are found below :

[FAN53610AUC33X](#) [FAN53611AUC123X](#) [EN6310QA](#) [160215](#) [R3](#) [KE177614](#) [FAN53611AUC12X](#) [MAX809TTR](#) [NCV891234MW50R2G](#)
[AST1S31PUR](#) [NCP81203PMNTXG](#) [NCP81208MNTXG](#) [PCA9412AUKZ](#) [NCP81109GMNTXG](#) [NCP3235MNTXG](#) [NCP81109JMNTXG](#)
[NCP81241MNTXG](#) [NTE7223](#) [NTE7222](#) [NTE7224](#) [L6986FTR](#) [MPQ4481GU-AEC1-P](#) [MP8756GD-P](#) [MPQ2171GJ-P](#) [MPQ2171GJ-AEC1-P](#)
[N JW4153U2-A-TE2](#) [MP2171GJ-P](#) [MP28160GC-Z](#) [XDPE132G5CG000XUMA1](#) [LM60440AQRPKRQ1](#) [MP5461GC-P](#)
[NCV896530MWATXG](#) [MPQ4409GQBE-AEC1-P](#) [S-19903DA-A8T1U7](#) [S-19903CA-A6T8U7](#) [S-19903CA-S8T1U7](#) [S-19902BA-A6T8U7](#)
[S-19902CA-A6T8U7](#) [S-19902AA-A6T8U7](#) [S-19903AA-A6T8U7](#) [S-19902AA-S8T1U7](#) [S-19902BA-A8T1U7](#) [AU8310](#)
[LMR23615QDRRRQ1](#) [LMR33630APAQRN XRQ1](#) [LMR33630APCQRN XRQ1](#) [LMR36503R5RPER](#) [LMR36503RFRPER](#)
[LMR36503RS3QRPERQ1](#) [LMR36506R5RPER](#)