

Features

Evaluation Module

- Evaluation platform for RPM-2.0 buck regulator modules
- Thermal design considerations included
- EMI Class B filter
- Easy evaluation of trimming, sequencing, soft start, enable and sensing functions

RPM-2.0-EVM-1

Description

The RPM3.3-2.0-EVM-1 and RPM5.0-2.0-EVM-1 generate a constant output voltage with an output current up to 2A from an external DC Source. All the functions of the RPM3.3-2.0 and RPM5.0-2.0 like trimming, sequencing, soft-start, enable and sensing can be evaluated. Also the behavior in overload or over temperature can be evaluated easily before it is designed in. There are also evaluation modules with other output currents available.



Selection Guide

Part Number	Input Voltage Range [VDC]	Output Voltage [VDC]	Output Current [A]
RPM3.3-2.0-EVM-1	3 - 17	3.3	2
RPM5.0-2.0-EVM-1	3 - 17	5	2

Quick Start Guide

- 1) Connect CON1 to power supply
- 2) Connect CON2 to a Load
- 3) Connect sense to the required potential
The sense preset is via R3 directly at the power module, so the preset voltage is very accurate at the output of the RPM. To equalize ohmic losses of the filter, remove the resistor at R3, and solder a 0Ω resistor at R4. To sense directly at the load, desolder R3 and R4, and connect Pin3 of CON2 to the positive potential of the load.

Notice: if voltage drop from the output to the load is too high, voltage overshoots may occur – especially during load jumps.
- 4) Disable the device via CON3
The device is preset as normally on. It can be disabled by pulling the enable pin to GND. Short R1 to disable the device.

Component Placement

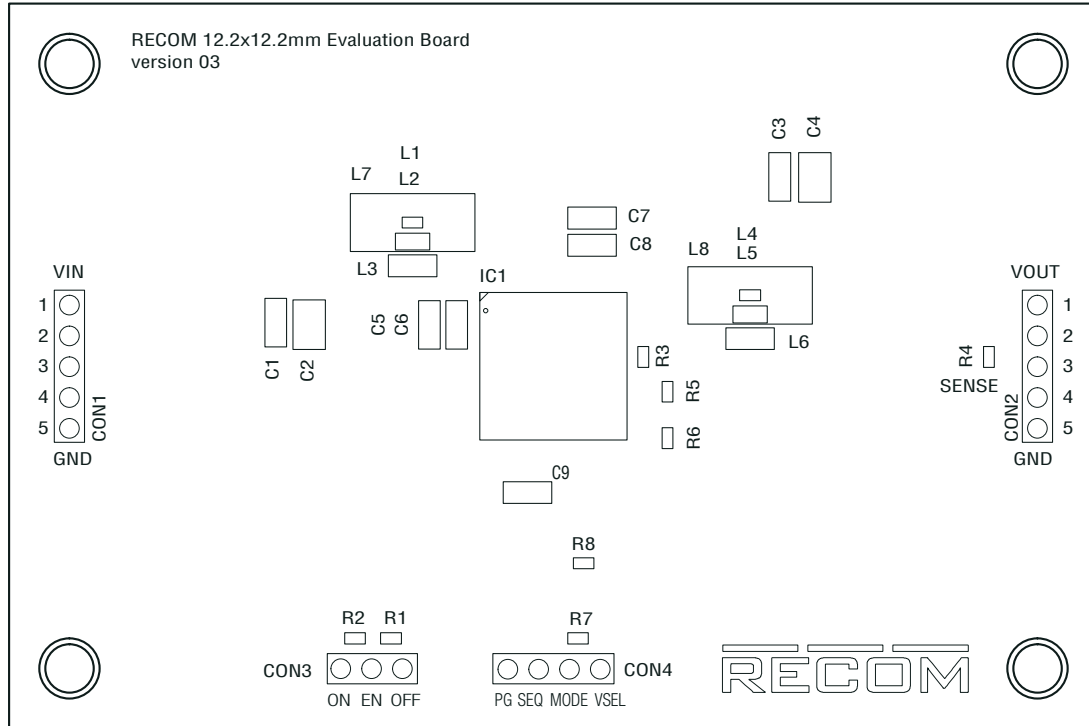

Connector Description

Con1

Pin	Name	Description
1,2	V _{in}	Positive Input Voltage (observe correct polarity!)
3	NC	Not connected
4,5	GND	Negative Input Voltage (Common GND)

Con2

Pin	Name	Description
1,2	V _{out}	Positive Output Voltage
3	SENSE	Output Voltage Sense Pin (leave open if not used)
4,5	GND	Negative Output Voltage (Common GND)

Con3

Pin	Name	Description
1	ON	Connect to Vin
2	EN	Enable Pin (leave open if not used)
3	OFF	Connected to GND

Con4

Pin	Name	Description
1	PG	Power Good Signal
2	SEQ	Sequencing and soft start
3	MODE	Not used
4	VSEL	Not used

Specifications (measured @ Ta= 25°C, full load after warm up unless otherwise stated)

Schematic

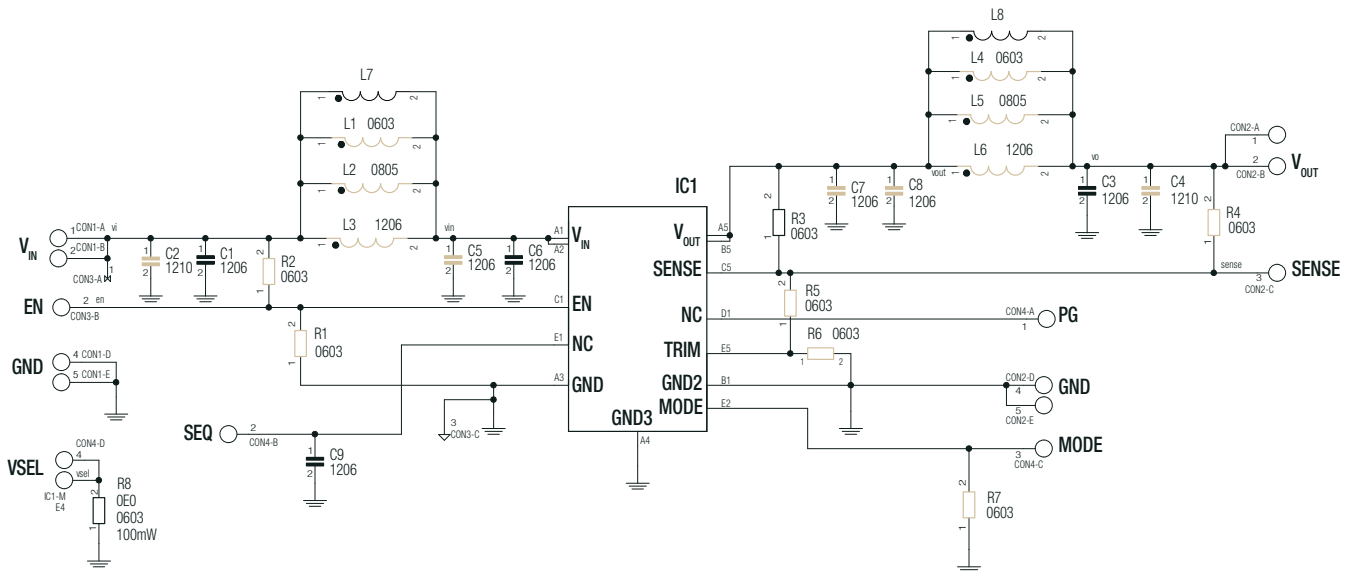

Description

IC1: RPM-2.0 power module.

C1,C2,L1,L2,L3,L7,C5,C6: allow placement of various sized components to test input filter design. The populated filter is designed to meet EN55032 class B.

C7,C8,L4,L5,L6,L8,C3,C4: allow placement of various sized components to test output filter design. The populated filter is designed to meet EN55032 class B.

R1 and R2: configure enable pin. These resistors are not populated. The preset of IC1 is always on. Refer to IC1 datasheet for more information.

C9: sets soft-start time. Refer to IC1 datasheet for more information.

R3: populated 0Ω resistor for direct output voltage measurement. If sense is desired at a different location, for example after the filter or directly at the load, unsolder R3, and connect sense to the new measurement point.

R4: sense point for output voltage after the filter. To set sense point here, remove R3 and solder a 0Ω resistor at R4.

R7 and R8: no function on this board.

R5 and R6: trim the output voltage between 0.9V and 6.0V

OUTPUT VOLTAGE TRIMMING

The RPM series offers the feature of trimming the output voltage over a range between 0.9V and 6V by using external trim resistors. The values for trim resistors shown in trim tables below are according to standard E96 values; therefore, the specified voltage may slightly vary.

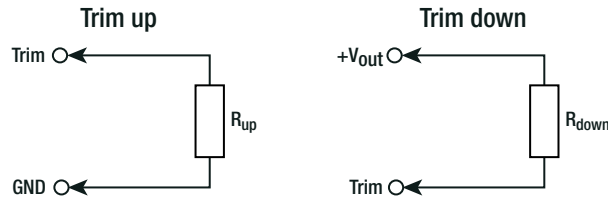

- V_{out_nom} = nominal output voltage [VDC]
- V_{out_set} = trimmed output voltage [VDC]
- V_{ref} = reference voltage [VDC]
- R_{up} = trim up resistor [Ω]
- R_{down} = trim down resistor [Ω]
- R_1, R_2, R_3 = internal resistors [Ω]

V_{out_nom}	R_1	R_2	R_3	V_{ref}
3.3VDC	376k Ω	1k Ω	471k Ω	0.81VDC
5VDC	344k Ω		431k Ω	

Calculation:

$$R_{up} = \left[\frac{R_1}{V_{out_set} - V_{nom}} \right] - R_2$$

$$R_{down} = \left[\frac{(V_{out_set} - V_{ref}) \times R_3}{V_{out_nom} - V_{out_set}} \right]$$

Practical Example RPM3.3-2.0:

$$R_{up} = \left[\frac{376k}{4.3 - 3.3} \right] - 1k = \underline{\underline{375k\Omega}}$$

$$R_{down} = \left[\frac{(1.8 - 0.81) \times 471k}{3.3 - 1.8} \right] = \underline{\underline{311k\Omega}}$$

$$R_{up} \text{ according to E96} \approx \underline{\underline{374k\Omega}}$$

$$R_{down} \text{ according to E96} \approx \underline{\underline{309k\Omega}}$$

RPM3.3-2.0

Trim up

$V_{out_set} =$	3.5	3.7	3.9	4.1	4.3	4.5	4.7	5.0	5.5	6.0	[VDC]
$R_{up} (E96) \approx$	1M91	953k	634k	475k	374k	316k	267k	221k	169k	137k	[Ω]

Trim down

$V_{out_set} =$	3.0	2.7	2.5	2.2	2.0	1.8	1.5	1.2	1.0	0.9	[VDC]
$R_{down} (E96) \approx$	3M40	1M47	1M	590k	432k	309k	182k	86k6	39k2	17k4	[Ω]

RPM5.0-2.0

Trim up

$V_{out_set} =$	5.1	5.2	5.3	5.4	5.5	5.6	5.7	5.8	5.9	6.0	[VDC]
$R_{up} (E96) \approx$	3M32	1M69	1M15	866k	681k	576k	487k	422k	383k	340k	[Ω]

Trim down

$V_{out_set} =$	4.5	4.0	3.5	3.3	2.5	1.8	1.5	1.2	1.0	0.9	[VDC]
$R_{down} (E96) \approx$	3M16	1M37	768k	634k	294k	133k	84k5	44k2	20k5	9k53	[Ω]

Evaluation Module

Specifications (measured @ Ta= 25°C, full load after warm up unless otherwise stated)

DIMENSION AND PHYSICAL CHARACTERISTICS

Parameter	Type	Value
Dimension (LxWxH)		90.0 x 60.0 x 26.0mm
Weight		23.3g typ.

Layout

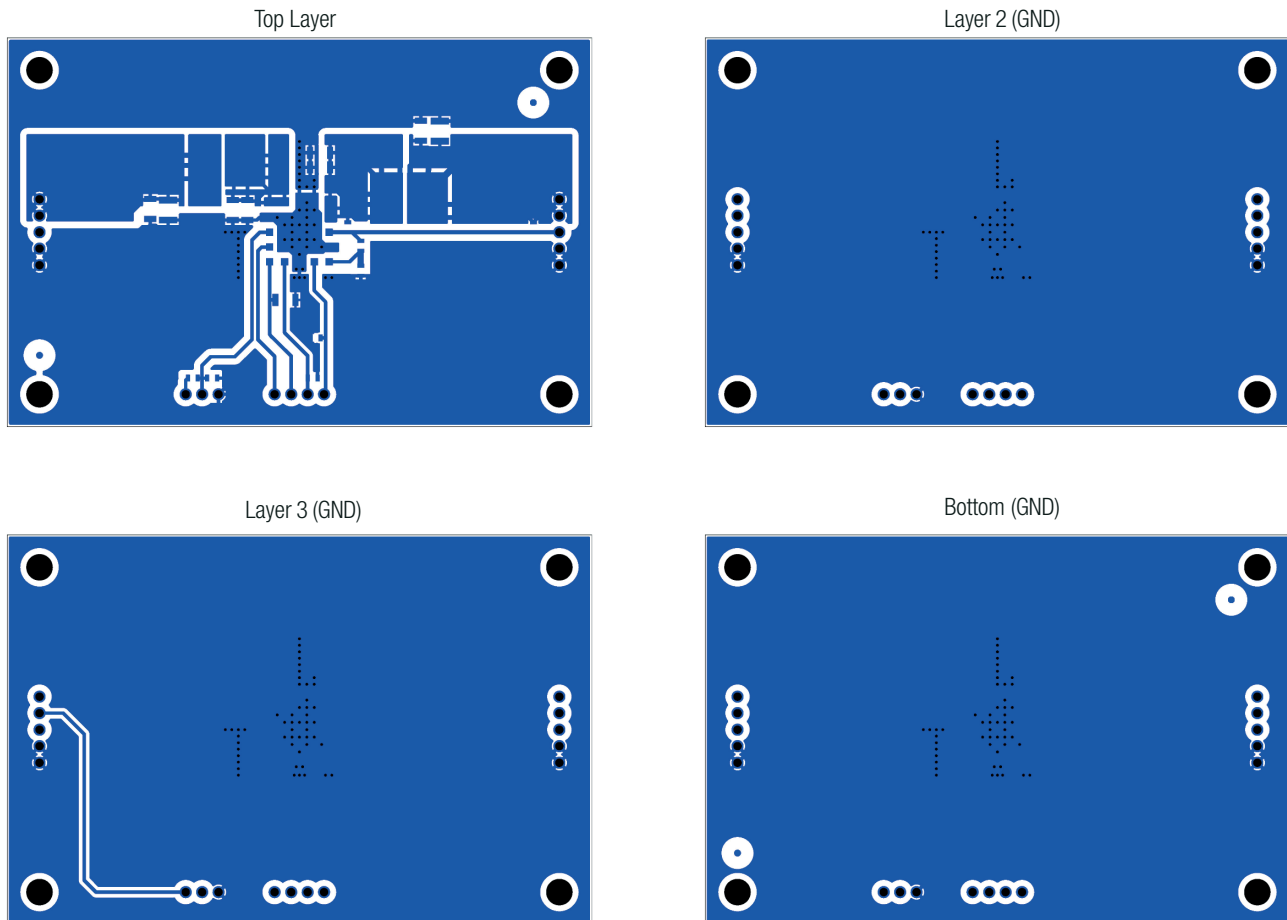

Notes:

Note1: Visit www.recom-power.com/eval-ref-boards to download the Gerber files

BOM

Comp.	Description	Manufacturer Part Number	Manufacturer	Remarks
C2	10 μ F \pm 10% 63V X7R MLCC 1210	GRM32ER71J106KA12L	Murata	not mounted
C4	10 μ F \pm 10% 63V X7R MLCC 1210	GRM32ER71J106KA12L	Murata	not mounted
C1	10 μ F 35V X7R 1206	GMK316AB7106KL-TR	Taiyo Yuden	
C3	10 μ F 35V X7R 1206	GMK316AB7106KL-TR	Taiyo Yuden	
C5	10 μ F 35V X7R 1206	GMK316AB7106KL-TR	Taiyo Yuden	not mounted
C6	10 μ F 35V X7R 1206	GMK316AB7106KL-TR	Taiyo Yuden	

continued on next page

Specifications (measured @ Ta= 25°C, full load after warm up unless otherwise stated)

Comp.	Description	Manufacturer Part Number	Manufacturer	Remarks
C7	10µF 35V X7R 1206	GMK316AB7106KL-TR	Taiyo Yuden	not mounted
C8	10µF 35V X7R 1206	GMK316AB7106KL-TR	Taiyo Yuden	not mounted
C9	100nF 50V X7R 1206	CL31B104KBCNNNC	Samsung	not mounted
CON3	RS Pro Header 2.54mm 3 pin	W81103T3825RC	RS	
CON4	RS Pro Header 2.54mm 4 pin	W81104T3825RC	RS	
CON1	RS Pro Header 2.54mm 5 pin	W81105T3825RC	RS	
CON2	RS Pro Header 2.54mm 5 pin	W81105T3825RC	RS	
L7	FERRITE BEAD 70 OHM 2SMD 1LN	742792510	Würth Electronics	not mounted
L8	FERRITE BEAD 98 OHM 2SMD 1LN	7427932	Würth Electronics	not mounted
L3	FERRITE BEAD 80 OHM 1206 1LN	74279215	Würth Electronics	
L6	FERRITE BEAD 80 OHM 1206 1LN	74279215	Würth Electronics	
L2	FERRITE BEAD 330 OHM 0805 1LN	FBMH2012HM331-T	Taiyo Yuden	not mounted
L5	FERRITE BEAD 330 OHM 0805 1LN	FBMH2012HM331-T	Taiyo Yuden	not mounted
L1	FERRITE BEAD 600 OHM 0603 1LN	742792651	Würth Electronics	not mounted
L4	FERRITE BEAD 600 OHM 0603 1LN	742792651	Würth Electronics	not mounted
FD1 - FD4	Fiducial 1mm Cu with 3mm Solder Resist			
R1	RES SMD 0.00HM JUMPER 1/10W 0603	RC0603JR-070RL	Yageo	not mounted
R3	RES SMD 0.00HM JUMPER 1/10W 0603	RC0603JR-070RL	Yageo	
R4	RES SMD 0.00HM JUMPER 1/10W 0603	RC0603JR-070RL	Yageo	not mounted
R5	RES SMD 0.00HM JUMPER 1/10W 0603	RC0603JR-070RL	Yageo	not mounted
R6	RES SMD 0.00HM JUMPER 1/10W 0603	RC0603JR-070RL	Yageo	not mounted
R7	RES SMD 0.00HM JUMPER 1/10W 0603	RC0603JR-070RL	Yageo	not mounted
R8	RES SMD 0.00HM JUMPER 1/10W 0603	RC0603JR-070RL	Yageo	not mounted
R2	RES SMD 1M OHM 1% 1/10W 0603	RC0603FR-071ML	Yageo	not mounted
SP1 - SP4	Spacer 4mm	709955000	Würth Electronics	
IC1 ⁽²⁾	RPM Module	RPMxx-2.0	RECOM	

Notes:

Note2: IC1 is RPM5.0-2.0 for RPM5.0-2.0-EVM-1 and RPM3.3-2.0 for RPM3.3-2.0-EVM-1

PACKAGING INFORMATION

Parameter	Type	Value
Packaging Dimension (LxWxH)	carton	200.0 x 135.0 x 68.0mm
Packaging Quantity		1 pcs

Contents

- RPM-2.0-EVM-1 evaluation module
- Terms and conditions

The product information and specifications may be subject to changes even without prior written notice. The product has been designed for various applications; its suitability lies in the responsibility of each customer. The products are not authorized for use in safety-critical applications without RECOM's explicit written consent. A safety-critical application is an application where a failure may reasonably be expected to endanger or cause loss of life, inflict bodily harm or damage property. The applicant shall indemnify and hold harmless RECOM, its affiliated companies and its representatives against any damage claims in connection with the unauthorized use of RECOM products in such safety-critical applications.

X-ON Electronics

Largest Supplier of Electrical and Electronic Components

Click to view similar products for [Power Management IC Development Tools](#) category:

Click to view products by [Recom Power](#) manufacturer:

Other Similar products are found below :

[EVAL-ADM1168LQEBZ](#) [EVB-EP5348UI](#) [MIC23451-AAAYFL EV](#) [MIC5281YMME EV](#) [DA9063-EVAL](#) [ADP122-3.3-EVALZ](#) [ADP130-0.8-EVALZ](#) [ADP130-1.2-EVALZ](#) [ADP130-1.5-EVALZ](#) [ADP130-1.8-EVALZ](#) [ADP1714-3.3-EVALZ](#) [ADP1716-2.5-EVALZ](#) [ADP1740-1.5-EVALZ](#) [ADP1752-1.5-EVALZ](#) [ADP1828LC-EVALZ](#) [ADP1870-0.3-EVALZ](#) [ADP1871-0.6-EVALZ](#) [ADP1873-0.6-EVALZ](#) [ADP1874-0.3-EVALZ](#) [ADP1882-1.0-EVALZ](#) [ADP199CB-EVALZ](#) [ADP2102-1.25-EVALZ](#) [ADP2102-1.875EVALZ](#) [ADP2102-1.8-EVALZ](#) [ADP2102-2-EVALZ](#) [ADP2102-3-EVALZ](#) [ADP2102-4-EVALZ](#) [ADP2106-1.8-EVALZ](#) [ADP2147CB-110EVALZ](#) [AS3606-DB](#) [BQ24010EVM](#) [BQ24075TEVM](#) [BQ24155EVM](#) [BQ24157EVM-697](#) [BQ24160EVM-742](#) [BQ24296MEVM-655](#) [BQ25010EVM](#) [BQ3055EVM](#) [NCV891330PD50GEVB](#) [ISLUSBI2CKIT1Z](#) [LM2744EVAL](#) [LM2854EVAL](#) [LM3658SD-AEV/NOPB](#) [LM3658SDEV/NOPB](#) [LM3691TL-1.8EV/NOPB](#) [LM4510SDEV/NOPB](#) [LM5033SD-EVAL](#) [LP38512TS-1.8EV](#) [EVAL-ADM1186-1MBZ](#) [EVAL-ADM1186-2MBZ](#)