

Features

Evaluation Module

- Evaluation platform for RPX-1.0 buck regulator module
- Thermal design considerations included
- EMI class B filter
- Easy evaluation of output voltage selection, control, and sensing functions

RECOM
Evaluation Module

RPX-1.0-EVM-1

Description

The RPX-1.0-EVM-1 generates a constant output voltage selectable from 0.8V, 1.8V, 3.3V, 5V, 12V, 15V, or 24V from a DC input in the range of 4-36V. It has a maximum continuous output current of 1A.

All the functions of the RPX-1.0 such as output voltage selection, control, power good, trim, and output sense can be readily evaluated. Also the behavior in overload or over-temperature can be evaluated easily before it is designed in.

The evaluation board also contains the filter components to meet EMC class B levels. Alternate component positions are included to allow experimentation to optimize the EMC performance depending on operating conditions and budget.

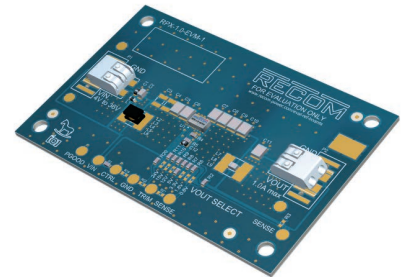

Selection Guide

Part Number	Input Voltage Range [VDC]	Output Voltage ⁽¹⁾ [VDC]	Output Current max. [A]
RPX-1.0-EVM-1	4 - 36	0.8, 1.8, 3.3, 5, 12, 15, 24	1

Notes:

Note1: refer to [SAFE OPERATING AREA](#) of RPX-1.0 datasheet

Quick Start Guide

1. Connect P3 to power supply (observe correct polarity!)
2. Connect P4 to the load (no load operation is allowed. For 0.8Vout, please refer to safe operating area in the [RPX-1.0](#) datasheet)
3. The evaluation module is preset to 5Vout.
The output voltage can be selected with values of 0.8V, 1.8V, 3.3V, 5V, 12V, 15V, and 24V by shorting a 0Ω resistor to the respective places as seen in the board silkscreen. For 0.8Vout, please refer to safe operating area in the [RPX-1.0](#) datasheet.
4. The sense pin is connected to the RPX output pin, so the preset voltage is very accurate at the output of the RPX. To compensate any losses of the filter, remove the resistor at R2, and solder a 0Ω resistor at R3.
5. CTRL
The device is preset as normally on. It can be disabled by pulling the CTRL pad to GND. Short R18 to disable the device.



Caution:

ESD sensitive. Always follow ESD preventative procedures when handling the product!

Specifications (measured @ Ta= 25°C, full load and after warm-up unless otherwise stated)

Component Placement

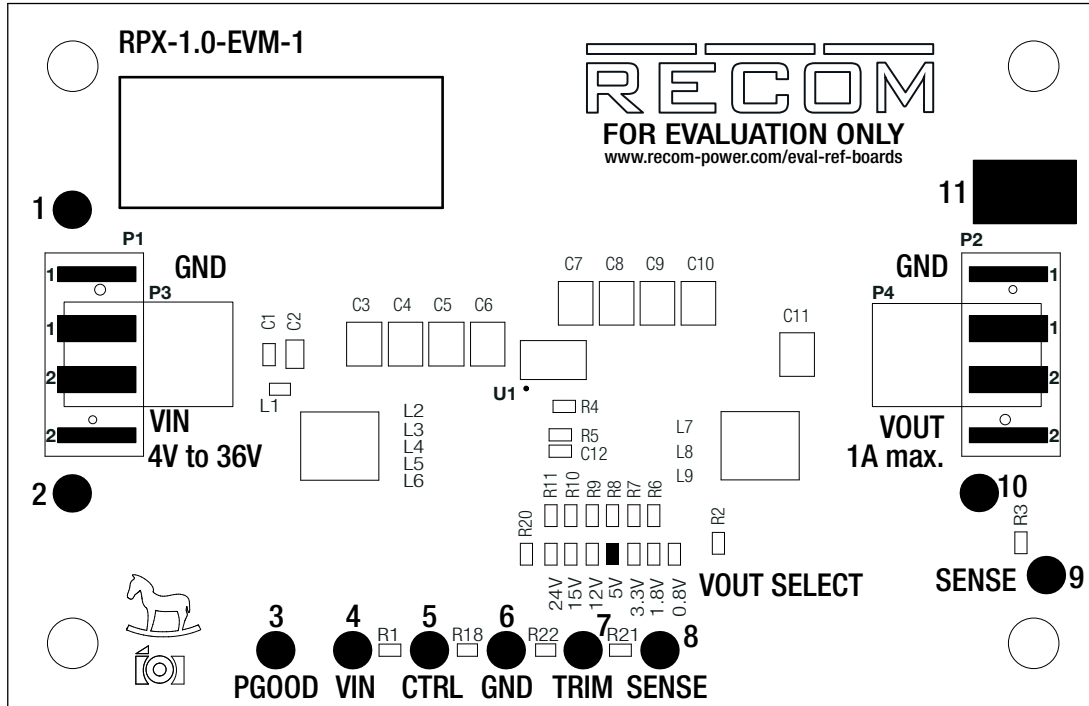

Connector Description

P1 (Not Mounted)

Pin	Name	Description
1	NC	No Connection
2	NC	No Connection

P3

Pin	Name	Description
1	GND	Common GND
2	VIN	Positive Input Voltage (observe correct polarity!)

P2 (Not Mounted)

Pin	Name	Description
1	NC	No Connection
2	NC	No Connection

P4

Pin	Name	Description
1	GND	Common GND
2	VOUT	Positive Output Voltage

Pads Direct Connection

Pin	Name	Description
1	GND	Negative Input Voltage (GND)
2	VIN	Positive Input Voltage
3	PGOOD	Power Good Signal
4	VIN	Positive Input Voltage
5	CTRL	CTRL Pad (leave open if not used)
6	GND	Negative Input Voltage (GND)
7	TRIM	TRIM Pad (leave open if not used)
8, 9	SENSE	Output Voltage Sense Pin (leave open if not used)
10	VOUT	Positive Output Voltage
11	GND	Negative Output Voltage (GND)

Specifications (measured @ Ta= 25°C, full load and after warm-up unless otherwise stated)

Schematic

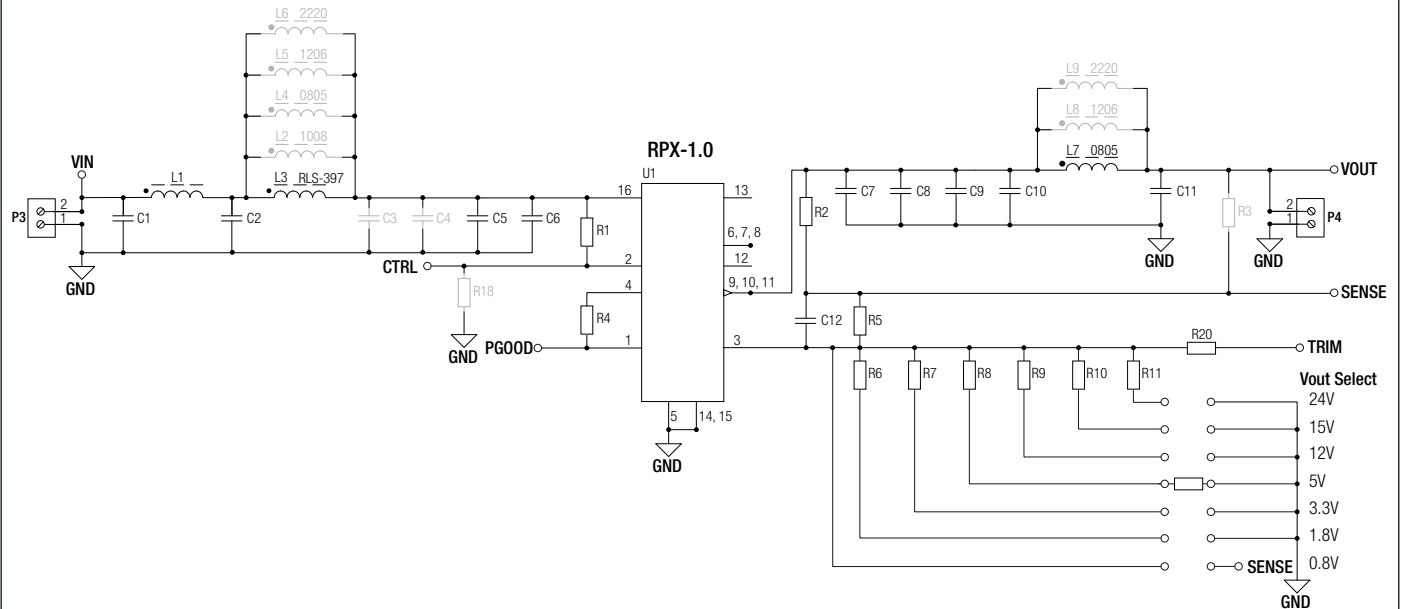

Notes:

Note2: Gray colored components are not mounted

Description

U1: RPX-1.0 power module.

C1,C2,L1,L2,L3,L4,L5,L6,C3,C4,C5,C6: allow placement of various sized components to test input filter design. The populated filter is designed to meet EN55022 class B.

C7,C8,C9,C10,L7,L8,L9,C11: allow placement of various sized components to test output filter design. The populated filter is designed to meet EN55022 class B.

R1 and R18: configure CTRL. R1 is populated to enable the RPX-1.0. Short R18 in order to disable the RPX-1.0.

R2: populated 0Ω resistor for direct output voltage measurement. If sense is desired at a different location, for example after the filter or directly at the load, unsolder R2, and connect sense to the new measurement point.

R3: sense point for output voltage after the filter. To set sense point here, remove R2, and solder a 0Ω resistor at R3.

VOUT selection: the output voltage can be selected with values of 0.8V, 1.8V, 3.3V, 5V, 12V, 15V, and 24V by shorting a 0Ω resistor to the respective places as seen in the board silkscreen.

R21, R22: trim the output voltage. Refer to **"OUTPUT VOLTAGE TRIMMING"**

OUTPUT VOLTAGE TRIMMING

The RPX-1.0 offers the feature of trimming the output voltage by using external trim resistors. The values for trim resistors are shown in trim tables below according to E96 values; therefore, the specified voltage may slightly vary. Refer to *“Selection Guide”* for applicable Vout range.

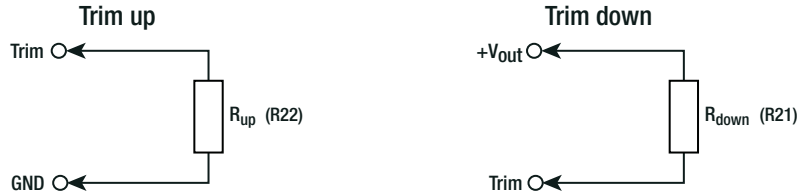

Calculation:

Vout_{nom} = nominal output voltage [VDC]
 Vout_{set} = trimmed output voltage [VDC]
 V_{ref} = reference voltage [VDC]
 R_{up} = trim up resistor [kΩ]
 R_{down} = trim down resistor [kΩ]
 R_{Hi}, R_{Lo} = internal resistors [kΩ]

R _{Hi}	R _{Lo}	V _{ref}
60k5Ω	75kΩ	0.807VDC

$$R_{up} = \left[\frac{R_{Hi}}{V_{out_set} - V_{nom}} \right] - 1k \quad R_{down} = \left[\frac{(V_{out_set} - V_{ref}) \times R_{Lo}}{V_{out_nom} - V_{set}} \right]$$

Practical Example RPX-1.0, trim up:

Vout_{set} = 5.1VDC

$$R_{up} = \left[\frac{60k5\Omega}{5.1 - 5} \right] - 1k = \underline{\underline{605k\Omega}}$$

R_{up} according to E96 ≈ 604kΩ

Vout_{set} = 1.8V

Trim up

Vout _{set} =	1.82	1.88	1.90	1.98	[VDC]
R _{up} (E96) ≈	3M01	750k	604k	332k	[Ω]

Trim down

Vout _{set} =	1.7	1.6	1.5	1.44	[VDC]
R _{down} (E96) ≈	665k	294k	174k	133k	[Ω]

Vout_{set} = 5V

Trim up

Vout _{set} =	5.1	5.2	5.3	5.5	[VDC]
R _{up} (E96) ≈	604k	301k	200k	121k	[Ω]

Trim down

Vout _{set} =	4.7	4.5	4.3	4	[VDC]
R _{down} (E96) ≈	976k	549k	374k	237k	[Ω]

Vout_{set} = 15V

Trim up

Vout _{set} =	15.5	16	16.3	16.5	[VDC]
R _{up} (E96) ≈	121k	59k	45k3	39k2	[Ω]

Trim down

Vout _{set} =	14	13	12.5	12	[VDC]
R _{down} (E96) ≈	1M	453k	348k	280k	[Ω]

Practical Example RPX-1.0, trim down:

Vout_{set} = 4VDC

$$R_{down} = \left[\frac{(4 - 0.807) \times 75k\Omega}{5 - 4} \right] = \underline{\underline{239k\Omega}}$$

R_{down} according to E96 ≈ 237kΩ

Vout_{set} = 3.3V

Trim up

Vout _{set} =	3.4	3.5	3.6	3.63	[VDC]
R _{up} (E96) ≈	604k	301k	200k	182k	[Ω]

Trim down

Vout _{set} =	3.1	3	2.8	2.64	[VDC]
R _{down} (E96) ≈	866k	549k	301k	210k	[Ω]

Vout_{set} = 12V

Trim up

Vout _{set} =	12.4	12.6	13	13.2	[VDC]
R _{up} (E96) ≈	150k	100k	59k	49k9	[Ω]

Trim down

Vout _{set} =	11	10.6	10	9.6	[VDC]
R _{down} (E96) ≈	768k	523k	348k	274k	[Ω]

Vout_{set} = 24V

Trim up

Vout _{set} =	25	25.5	26	26.4	[VDC]
R _{up} (E96) ≈	59k	39k2	29k4	24k3	[Ω]

Trim down

Vout _{set} =	23	22	20	19.2	[VDC]
R _{down} (E96) ≈	1M65	787k	357k	287k	[Ω]

Specifications (measured @ Ta= 25°C, full load and after warm-up unless otherwise stated)

DIMENSION AND PHYSICAL CHARACTERISTICS

Parameter	Type	Value
Dimension (LxWxH)		85.0 x 55.0 x 6.5mm
Weight		21.2g typ.

Layout

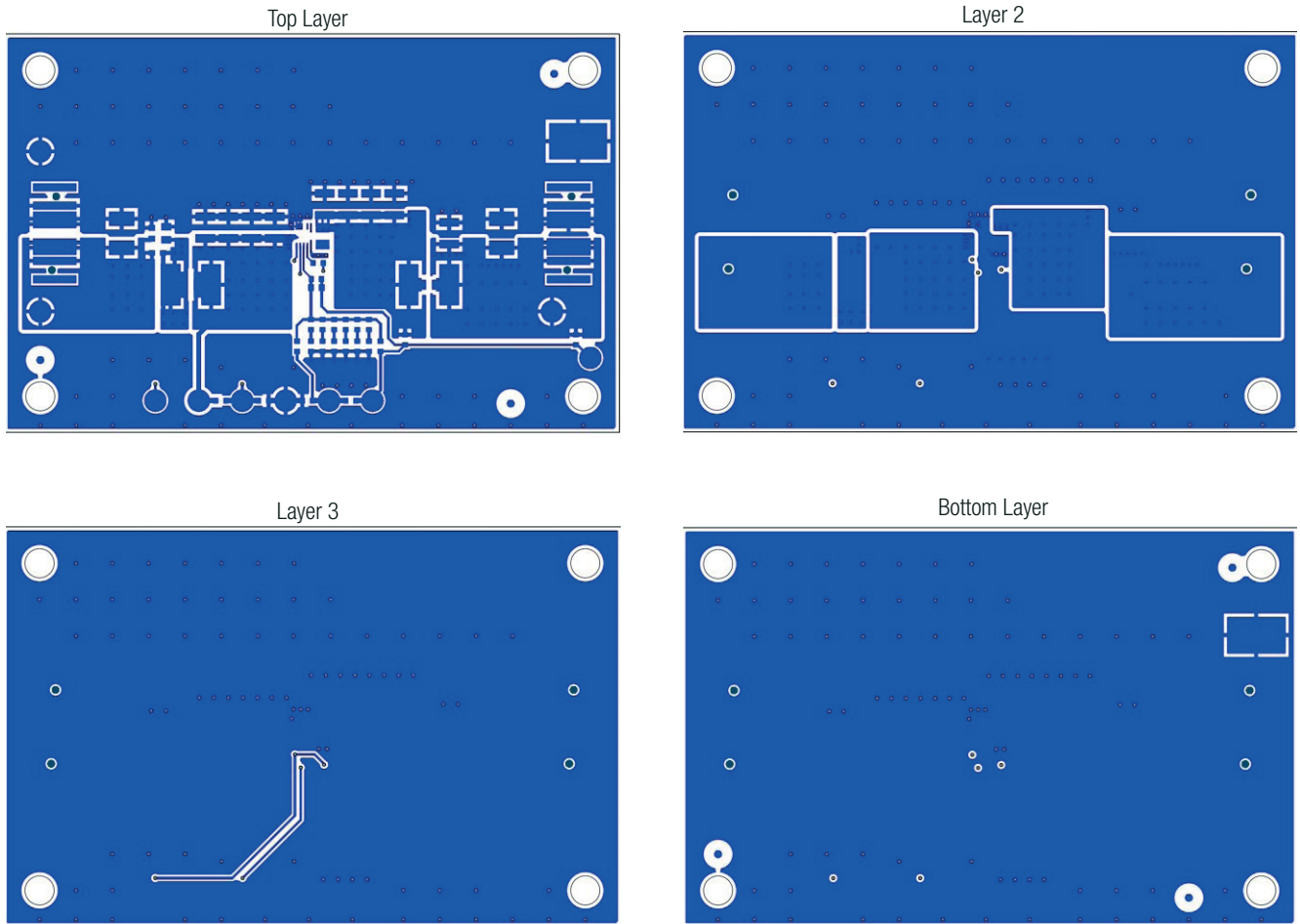

Notes:

Note3: Visit www.recom-power.com/eval-ref-boards to download the Gerber files

BOM

Comp.	Description	Manufacturer Part Number	Manufacturer	Remarks
C1	10nF 50V X7R 0603	CL10B103KB8NNNC	Samsung Electro-Mechanics	
C2	1µF 50V X7R 0805	CL21B105KBFNNNE	Samsung Electro-Mechanics	
C3	10µF 50V X7R 1210	CL32B106KBJNNWE	Samsung Electro-Mechanics	not mounted
C4	10µF 50V X7R 1210	CL32B106KBJNNWE	Samsung Electro-Mechanics	not mounted
C5	10µF 50V X7R 1210	CL32B106KBJNNWE	Samsung Electro-Mechanics	
C6	10µF 50V X7R 1210	CL32B106KBJNNWE	Samsung Electro-Mechanics	
C7	10µF 50V X7R 1210	CL32B106KBJNNWE	Samsung Electro-Mechanics	

continued on next page

Specifications (measured @ Ta= 25°C, full load and after warm-up unless otherwise stated)

Comp.	Description	Manufacturer Part Number	Manufacturer	Remarks
C8	10µF 50V X7R 1210	CL32B106KBJNNWE	Samsung Electro-Mechanics	
C9	10µF 50V X7R 1210	CL32B106KBJNNWE	Samsung Electro-Mechanics	
L10	10µF 50V X7R 1210	CL32B106KBJNNWE	Samsung Electro-Mechanics	
L11	10µF 50V X7R 1210	CL32B106KBJNNWE	Samsung Electro-Mechanics	
L12	33pF 50V COG 0603	CL10C330JB8NNNC	Samsung Electro-Mechanics	
L1	FERRITE BEAD BLM18PG330SN1D	BLM18PG330SN1D	Murata	
L2	FERRITE BEAD 1008			not mounted
L3	IND-3.9uH-1.32A-045x032x026	RLS-397	RECOM	
L4	FERRITE BEAD 0805			not mounted
L5	FERRITE BEAD 1206			not mounted
L6	FERRITE BEAD 2220			not mounted
L7	FERRITE BEAD 600 OHM 0805 1LN	742792040	Würth	
L8	FERRITE BEAD 1206			not mounted
L9	FERRITE BEAD 2220			not mounted
P1	CONNECTOR	XW4K-04A1-H1	Omron Electronics Inc	not mounted
P2	CONNECTOR	XW4K-04A1-H1	Omron Electronics Inc	not mounted
P3	CONNECTOR	2060-452/998-404	Wago	
P4	CONNECTOR	2060-452/998-404	Wago	
R1	100kΩ 0.1W 1% 0603	RC0603FR-07100KL	Yageo	
R2	0R 0.1W 0603	RC0603JR-070RL	Yageo	
R3	0R 0.1W 0603	RC0603JR-070RL	Yageo	not mounted
R4	100kΩ 0.1W 1% 0603	RC0603FR-07100KL	Yageo	
R5	75kΩ 0.1W 1% 0603	RC0603FR-0775KL	Yageo	
R6	60k4Ω 0.1W 1% 0603	RC0603FR-0760K4L	Yageo	
R7	24k3Ω 0.1W 1% 0603	RC0603FR-0724K3L	Yageo	
R8	14k3Ω 0.1W 1% 0603	RC0603FR-0714K3L	Yageo	
R9	5k36Ω 0.1W 1% 0603	RC0603FR-075K36L	Yageo	
R10	4k22Ω 0.1W 1% 0603	RC0603FR-074K22L	Yageo	
R11	2k61Ω 0.1W 1% 0603	RC0603FR-072K61L	Yageo	
R12	0R 0.1W 0603	RC0603JR-070RL	Yageo	not mounted
R13	0R 0.1W 0603	RC0603JR-070RL	Yageo	not mounted
R14	0R 0.1W 0603	RC0603JR-070RL	Yageo	not mounted
R15	0R 0.1W 0603	RC0603JR-070RL	Yageo	
R16	0R 0.1W 0603	RC0603JR-070RL	Yageo	not mounted
R17	0R 0.1W 0603	RC0603JR-070RL	Yageo	not mounted
R18	0R 0.1W 0603	RC0603JR-070RL	Yageo	not mounted
R19	0R 0.1W 0603	RC0603JR-070RL	Yageo	not mounted
R20	1kΩ 0.1W 1% 0603	RC0603FR-071KL	Yageo	
R21	0R 0.1W 0603	RC0603JR-070RL	Yageo	not mounted
R22	0R 0.1W 0603	RC0603JR-070RL	Yageo	not mounted
U1	RPX-1.0 MODULE	RPX-1.0	RECOM	

Specifications (measured @ Ta= 25°C, full load and after warm-up unless otherwise stated)

PACKAGING INFORMATION

Parameter	Type	Value
Packaging Dimension (LxWxH)		114.0 x 60.0 x 28.0mm
Packaging Quantity		1pc

Contents

- RPX-1.0-EVM-1 Evaluation Module
- Terms and Conditions

The product information and specifications may be subject to changes even without prior written notice. The product has been designed for various applications; its suitability lies in the responsibility of each customer. The products are not authorized for use in safety-critical applications without RECOM's explicit written consent. A safety-critical application is an application where a failure may reasonably be expected to endanger or cause loss of life, inflict bodily harm or damage property. The applicant shall indemnify and hold harmless RECOM, its affiliated companies and its representatives against any damage claims in connection with the unauthorized use of RECOM products in such safety-critical applications.

X-ON Electronics

Largest Supplier of Electrical and Electronic Components

Click to view similar products for [Power Management IC Development Tools](#) category:

Click to view products by [Recom Power](#) manufacturer:

Other Similar products are found below :

[EVAL-ADM1168LQEBZ](#) [EVB-EP5348UI](#) [MIC23451-AAAYFL EV](#) [MIC5281YMME EV](#) [DA9063-EVAL](#) [ADP122-3.3-EVALZ](#) [ADP130-0.8-EVALZ](#) [ADP130-1.2-EVALZ](#) [ADP130-1.5-EVALZ](#) [ADP130-1.8-EVALZ](#) [ADP1714-3.3-EVALZ](#) [ADP1716-2.5-EVALZ](#) [ADP1740-1.5-EVALZ](#) [ADP1752-1.5-EVALZ](#) [ADP1828LC-EVALZ](#) [ADP1870-0.3-EVALZ](#) [ADP1871-0.6-EVALZ](#) [ADP1873-0.6-EVALZ](#) [ADP1874-0.3-EVALZ](#) [ADP1882-1.0-EVALZ](#) [ADP199CB-EVALZ](#) [ADP2102-1.25-EVALZ](#) [ADP2102-1.875EVALZ](#) [ADP2102-1.8-EVALZ](#) [ADP2102-2-EVALZ](#) [ADP2102-3-EVALZ](#) [ADP2102-4-EVALZ](#) [ADP2106-1.8-EVALZ](#) [ADP2147CB-110EVALZ](#) [AS3606-DB](#) [BQ24010EVM](#) [BQ24075TEVM](#) [BQ24155EVM](#) [BQ24157EVM-697](#) [BQ24160EVM-742](#) [BQ24296MEVM-655](#) [BQ25010EVM](#) [BQ3055EVM](#) [NCV891330PD50GEVB](#) [ISLUSBI2CKIT1Z](#) [LM2744EVAL](#) [LM2854EVAL](#) [LM3658SD-AEV/NOPB](#) [LM3658SDEV/NOPB](#) [LM3691TL-1.8EV/NOPB](#) [LM4510SDEV/NOPB](#) [LM5033SD-EVAL](#) [LP38512TS-1.8EV](#) [EVAL-ADM1186-1MBZ](#) [EVAL-ADM1186-2MBZ](#)