

Features

Power Module

- Buck regulator power module with integrated shielded inductor
- 28V maximum input voltage
- 2.5A maximum output current
- SCP, OCP, OTP, OVP and UVLO protection
- 4.5mm x 4mm low profile QFN package
- Flip-Chip technology for improved thermal management
- Efficiency up to 91%



RPX-2.5

2.5 Amp QFN Package

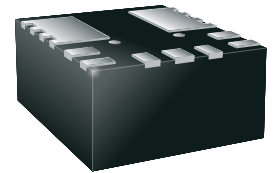

Description

The RPX-2.5 is a buck converter with integrated inductor in a tiny 4.5mm x 4mm x 2mm thermally-enhanced QFN package (the smallest in its class). The input range is from 4.5 to 28VDC, allowing 5V, 12V or 24V supply voltages to be used. The output voltage can be set with two resistors in the range from 1.2V up to 6V. The output current is up to 2.5A and is fully protected against continuous short-circuits, output overcurrent or over-temperature faults. The enable pin features an internal pull-up current source, so will operate with open-drain, open-collector, logic gate or switched inputs (leave open if not used).

Selection Guide

Part Number	Input Voltage Range [VDC] ⁽¹⁾	Vout Adjust Range [VDC] ⁽¹⁾	Output Current max. [A]	Efficiency max. [%] ⁽²⁾	Max. Capacitive Load ⁽³⁾ [µF]
RPX-2.5	4.5-28	1.2-6	2.5	91	500

Notes:

- Note1: Refer to **“Safe Operating Area”**
 Note2: Efficiency is tested at Vin= 12V, Iout= 1A, Vout= 5V
 Note3: Max. Cap Load is tested at nominal input and full resistive load

Model Numbering

RPX-2.5-CT

Output Current Packaging ⁽⁴⁾

Notes:

Note4: add suffix “-CT” for bag packaging for more details refer to **“PACKAGING INFORMATION”** without suffix, standard tape and reel packaging

Specifications (measured @ ta= 25°C, 12Vin, 3.3Vout, full load unless otherwise stated, refer to test set up)

ABSOLUTE MAXIMUM RATINGS				
Parameter	Condition	Min.	Typ.	Max.
Absolute Maximum Voltage ⁽⁵⁾	Vin	-0.3VDC		30VDC
	CTRL, FB	-0.3VDC		7VDC
	SW	-0.3VDC		30VDC
	SW transient	-5VDC		30VDC
	Vout	-0.3VDC		7VDC
Shock	according to MIL-STD-883D, method 2002.3; 1ms, 1/2 sine, mounted			1500G
Vibration	according to MIL-STD-883D, method 2007.7; 20Hz-2kHz			20G
Operating IC Junction Temperature (T _J)		-40°C		+125°C
Operating Ambient Temperature (T _{AMB})		-40°C		+85°C
Storage Temperature (T _{STO})		-55°C		+150°C

Notes:
 Note5: Stresses beyond those listed under absolute maximum ratings can cause permanent damage to the device. (Values are at non-operating)



www.recom-power.com/eval-ref-boards

Specifications (measured @ $t_a = 25^\circ\text{C}$, 12V_{in} , 3.3V_{out} , full load unless otherwise stated, refer to test set up)

OPERATING RATINGS

Parameter	Condition	Min.	Typ.	Max.
Input Voltage Range		4.5VDC ⁽⁶⁾		28VDC
Under Voltage Lockout (UVLO) (default setting) ⁽⁷⁾	DC-DC ON	3.8VDC	4.1VDC	4.4VDC
	DC-DC OFF	3.3VDC	3.6VDC	3.9VDC
Output Voltage Adjust Range	refer to "OUTPUT VOLTAGE SETTING"	1.2VDC		6VDC
CTRL Voltage Range		0VDC		6VDC
CTRL ON/OFF Thresholds	DC-DC ON (or open)		1.21VDC	1.28VDC
	DC-DC OFF (or short to GND)	1.1VDC	1.19VDC	
Input Current of CTRL Pin	$V_{\text{CTRL}} = 1.5\text{VDC}$ (DC-DC ON)		1.6 μA	
	$V_{\text{CTRL}} = 1\text{VDC}$ (DC-DC OFF)		0.7 μA	
Standby Current	DC-DC OFF		2 μA	
Output Current		0A		2.5A ⁽⁸⁾
Start-up Time	power on by using CTRL (without C_{OUT})		10ms	
			6ms	
Rise-time	(internal soft start)		5ms	
Switching Frequency		550kHz	750kHz	1MHz
Output Ripple and Noise ⁽⁹⁾	20MHz BW		22mVp-p	

Notes:

Note6: The minimum recommended input voltage is 4.5 V or ($V_{\text{OUT}} \times 1.3$), whichever is greater

Note7: Refer to **"UNDER VOLTAGE LOCKOUT SETTING"**

Note8: The maximum output current that the RPX can deliver is a function of input voltage, output voltage, and ambient temperature

Note9: Measurement with $C_{\text{IN}1} = 10\mu\text{F}$, 50V 1210 ceramic, $C_{\text{IN}2} = 100\mu\text{F}$, 35V electrolytic and $C_{\text{OUT}1,2} = 47\mu\text{F}$ 16V, ceramic capacitors

Test Set-up

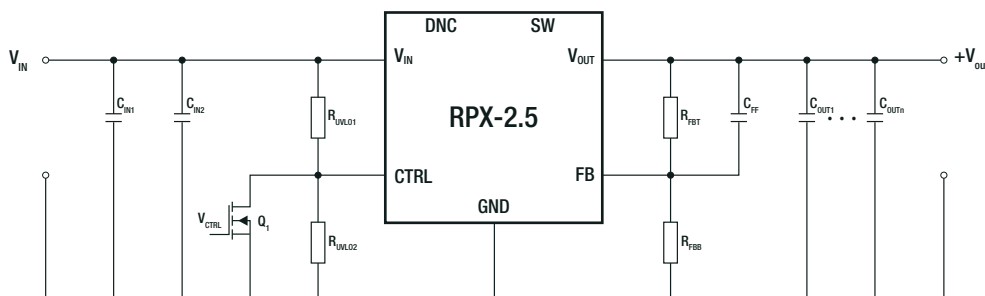

Safe Operating Area

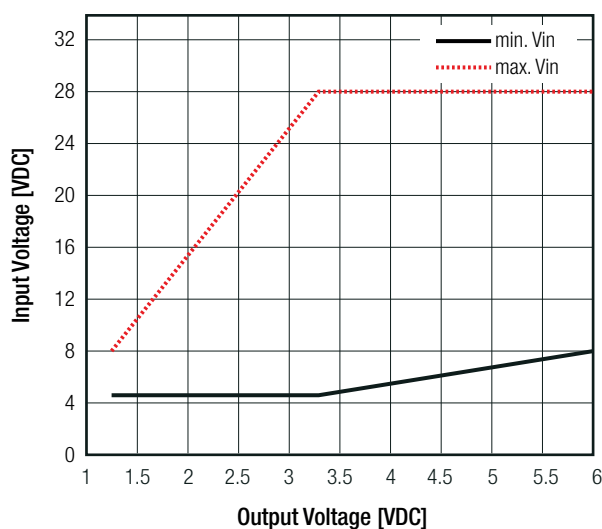

Typical operating conditions

Nominal Vin	Vout	Iout , max
24VDC	5VDC	2.0A
24VDC	3.3VDC	2.1A
12VDC	5VDC	2.5A
12VDC	3.3VDC	2.5A
5VDC	3.3VDC	2.5A
5VDC	1.2VDC	2.5A

Specifications (measured @ $t_a = 25^\circ\text{C}$, 12V_{in} , 3.3V_{out} , full load and after warm-up unless otherwise stated, refer to test set up)

Efficiency vs. output current

$V_{\text{out}} = 3.3\text{VDC}$, $V_{\text{in}} = 12\text{VDC}$ (2.5A max)

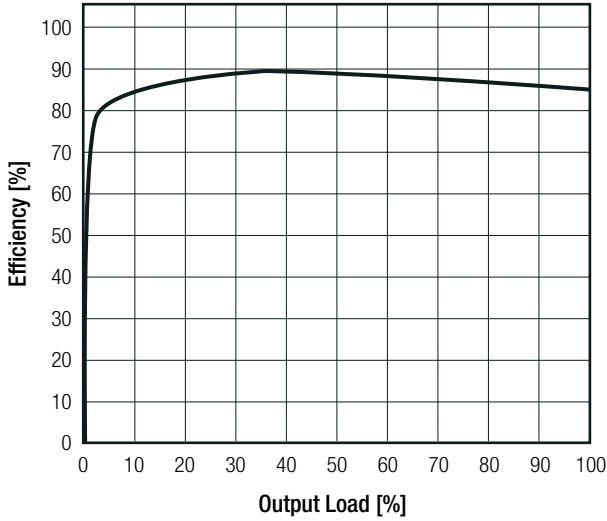

$V_{\text{out}} = 5\text{VDC}$, $V_{\text{in}} = 12\text{VDC}$ (2.5A max)

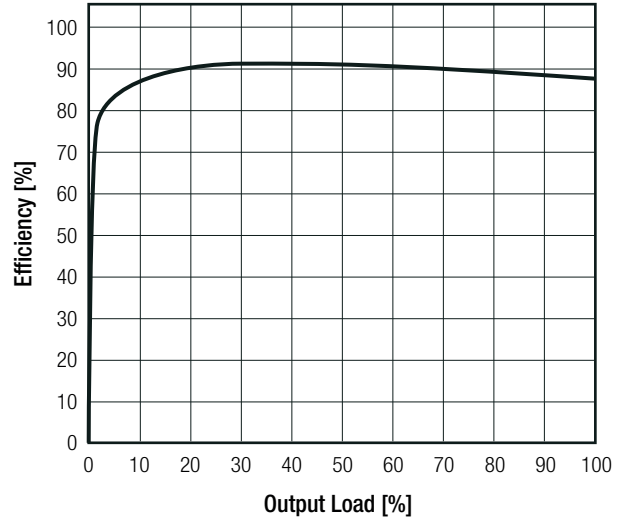

$V_{\text{out}} = 3.3\text{VDC}$, $V_{\text{in}} = 24\text{VDC}$ (2.0A max)

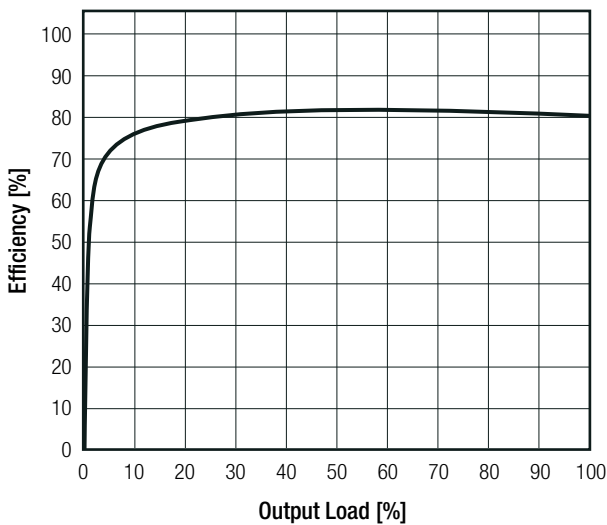

$V_{\text{out}} = 5\text{VDC}$, $V_{\text{in}} = 24\text{VDC}$ (2.1A max.)

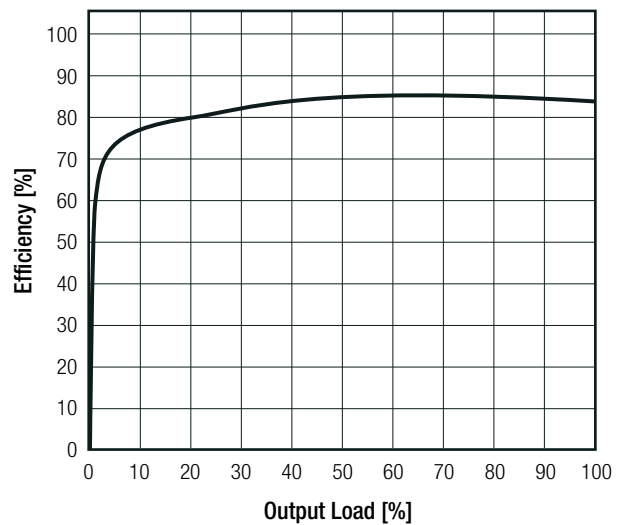

UNDER VOLTAGE LOCKOUT SETTING

The RPX-2.5 features an internal UVLO circuit that disables the converter until the input voltage exceeds 4.1V typ. This threshold can be raised by adding an external resistor divider R_{UVLO1} and R_{UVLO2} .

Standard Resistor Values					
$V_{\text{IN UVLO}}$ [VDC]	4.5	10	15	18	20
R_{UVLO1} [k Ω]	68.1	68.1	68.1	68.1	68.1
R_{UVLO2} [k Ω]	25.5	9.53	6.04	4.99	4.42

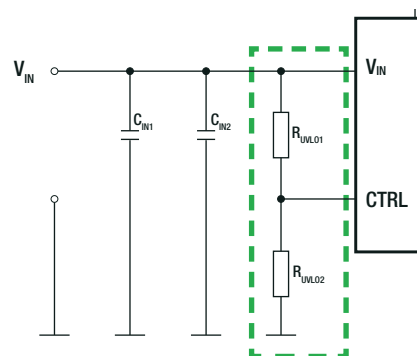

Specifications (measured @ $t_a = 25^\circ\text{C}$, 12Vin, 3.3Vout, full load and after warm-up unless otherwise stated, refer to test set up)

POSITIVE TO NEGATIVE

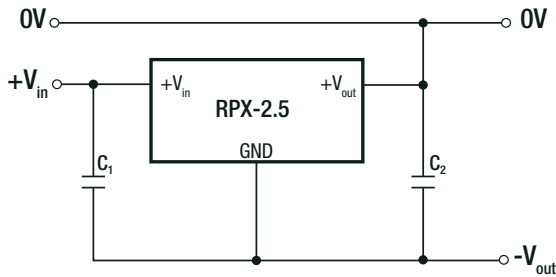

C_1 and C_2 may be added to reduced ripple and should be fitted close to the converter pins.

Notes:

Note10: RECOM Power Modules can also be used to convert a positive voltage into a negative voltage. Parameters such as maximum Vin, efficiency and maximum operating temperature are reduced. Please contact RECOM for further details.

OUTPUT VOLTAGE SETTING

The recommended value of R_{FBT} is $10\text{k}\Omega$. The values for trim resistors shown in trim tables below are according to standard E96 values; therefore, the specified voltage may slightly vary. For other output voltages, the value of the required R_{FBB} resistor can be calculated using below equation:

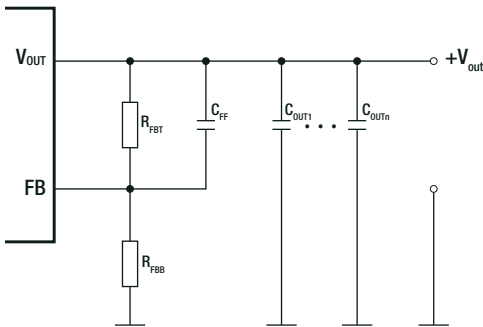

- $V_{out_{nom}}$ = nominal output voltage [VDC]
- $V_{out_{set}}$ = trimmed output voltage [VDC]
- V_{REF} = reference voltage (6VDC) [VDC]
- d = trim offset (0.6VDC) [VDC]
- R_{FBT} = Trim resistor ($10\text{k}\Omega$) [$\text{k}\Omega$]
- R_{FBB} = calculated trim resistor [$\text{k}\Omega$]

Calculation:

$$R_{FBB} = \left[\frac{V_{REF}}{V_{out_{set}} - d} \right]$$

Practical Example:

$$R_{FBB} = \left[\frac{6\text{VDC}}{3.3\text{VDC} - 0.6} \right] = 2.22\text{k}\Omega \quad R_{FBB} \text{ according to E96} \approx \underline{2.21\text{k}\Omega}$$

Resistor Table:

$V_{out_{set}} =$	1.2	1.3	1.4	1.5	1.6	1.7	1.8	1.9	2	2.1	[VDC]
R_{FBB} (E96) \approx	10k	8k45	7k5	6k65	6k04	5k36	4k99	4k64	4k22	4k02	[Ω]
$V_{out_{set}} =$	2.2	2.3	2.4	2.5	2.6	2.7	2.8	2.9	3	3.1	[VDC]
R_{FBB} (E96) \approx	3k74	3k48	3k32	3k16	3k01	2k87	2k74	2k61	2k49	2k37	[Ω]
$V_{out_{set}} =$	3.2	3.3	3.4	3.5	3.6	3.7	3.8	3.9	4	4.1	[VDC]
R_{FBB} (E96) \approx	2k32	2k21	2k15	2k05	2k	1k96	1k87	1k82	1k74	1k69	[Ω]
$V_{out_{set}} =$	4.2	4.3	4.4	4.5	4.6	4.7	4.8	4.9	5	5.1	[VDC]
R_{FBB} (E96) \approx	1k65	1k62	1k58	1k54	1k5	1k47	1k43	1k4	1k37	1k33	[Ω]
$V_{out_{set}} =$	5.2	5.3	5.4	5.5	5.6	5.7	5.8	5.9	6	[VDC]	
R_{FBB} (E96) \approx	1k3	1k27	1k24	1k22	1k2	1k18	1k15	1k13	1k1	[Ω]	

Specifications (measured @ $t_a = 25^\circ\text{C}$, 12V_{in} , 3.3V_{out} , full load and after warm-up unless otherwise stated, refer to test set up)

INPUT AND OUTPUT CAPACITOR

Input Capacitor

The RPX-2.5 requires a $10\mu\text{F}$ MLCC input capacitor for normal operation. For high transient load applications, an additional $47\mu\text{F}$ electrolytic capacitor connected in parallel is recommended, rated for a ripple current of 1.25A or higher.

Output Capacitor

The RPX-2.5 requires MLCC output capacitors for normal operation (see table). Transient load reaction time can be improved by adding a speedup capacitor, C_{FF} across R_{FBT} , but it is not required for normal operation or for output voltages below 2.5V .

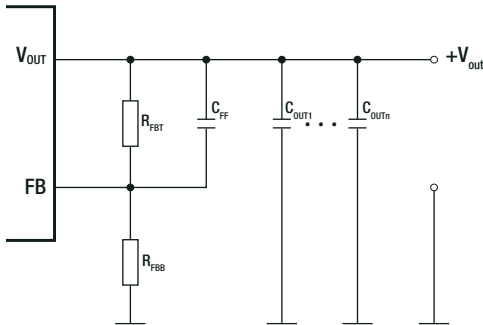

Minimum output capacitance			
Set Output Voltage [VDC]		Ceramic Capacitor (C_{OUTn}) [μF]	Feed Forward Capacitor (C_{FF}) [pF]
MIN	MAX		
1.2	<1.5	188 (4 x $47\mu\text{F}$)	330
1.5	<2.5	141 (3 x $47\mu\text{F}$)	220
2.5	<3.3	94 (2 x $47\mu\text{F}$)	100
3.3	<5	94 (2 x $47\mu\text{F}$)	100
5	<6	47	100

CTRL ON/OFF

The external CTRL input can also be used to disable the converter by pulling the CTRL pin to ground. An internal pull-up current source allows an external switch, open-collector transistor, open-drain transistor or a $3.3\text{V}/5\text{V}$ logic gate to be used to drive the CTRL pin. The UVLO adjust and external CTRL functions can be combined.

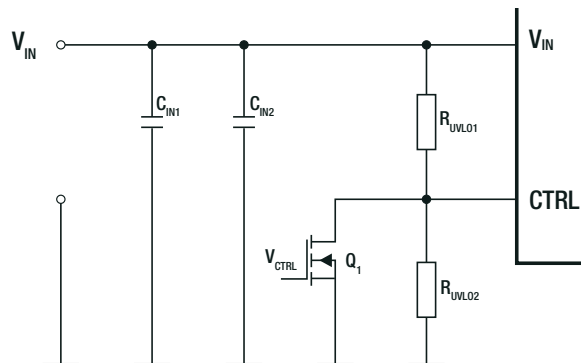

REGULATIONS

Parameter	Condition	Min.	Typ.	Max.
Feedback Voltage	no load	0.581VDC	0.596VDC	0.611VDC
Temperature Coefficient	$I_{\text{OUT}} = 0.2\text{A}$		0.003%/K	
Line Regulation	low line to high line		$\pm 0.2\%$	
Load Regulation	5 - 100% load		0.2%	
	0 - 5% load		0.5%	
Transient Response	10 <-> 100% load step change recovery time		6ms	200mV
	25% <-> 75% load step change recovery time		125 μs	100mV

Specifications (measured @ $t_a = 25^\circ\text{C}$, 12Vin , 3.3Vout , full load and after warm-up unless otherwise stated, refer to test set up)

PROTECTIONS

Parameter	Condition	Value
Short Circuit Protection (SCP)		Hiccup Mode, auto recovery
Over Current Protection (OCP)		4.8A typ., hiccup mode
Over Temperature Protection (OTP)	internal junction	165°C typ., thermal shut down 10°C typ. restart hysteresis

ENVIRONMENTAL

Parameter	Condition	Value	
ESD	human-body model (HBM), ANSI/ESDA/JEDEC JS-001	$\pm 2.5\text{kV}$	
	charged-device model (CDM), JEDEC JESD22-C101	$\pm 1\text{kV}$	
Moisture Sensitive Level	MSL peak temp. ⁽¹¹⁾	Level 3, 260°C, 168hrs	
Thermal Impedance ⁽¹²⁾	junction to T_{AMB}	32.7K/W	
	junction to case (refer to tc point)	2.2K/W	
	junction to board (refer to tb point)	17K/W	
MTBF	according to TR-332, 50% stress G.B.	+25°C	400 x 10 ⁶ hours
		+85°C	6 x 10 ⁶ hours

Notes:

Note11: The Moisture Sensitivity Level rating according to the JEDEC industry standard classifications, and peak solder temperature

Thermal Derating ⁽¹¹⁾

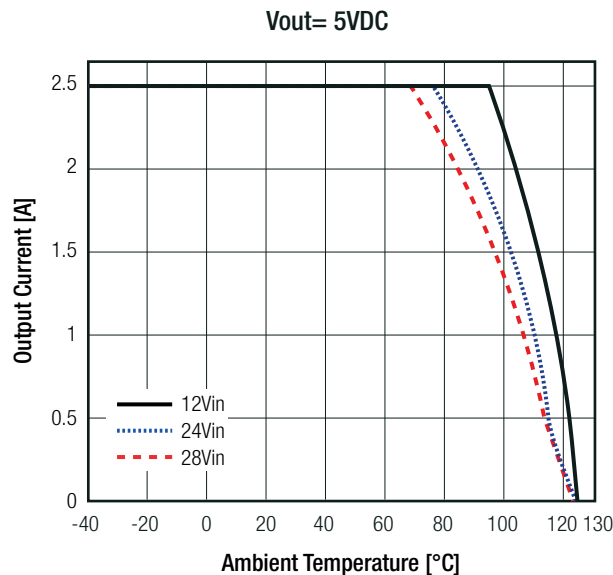

Notes:

Note12: Tested with 54.0 x 85.6mm 2 layer PCB with 105µm copper

continued on next page

Specifications (measured @ $t_a = 25^\circ\text{C}$, 12V_{in} , 3.3V_{out} , full load and after warm-up unless otherwise stated, refer to test set up)

Input voltage vs. output current
(tested without additional test PCB)

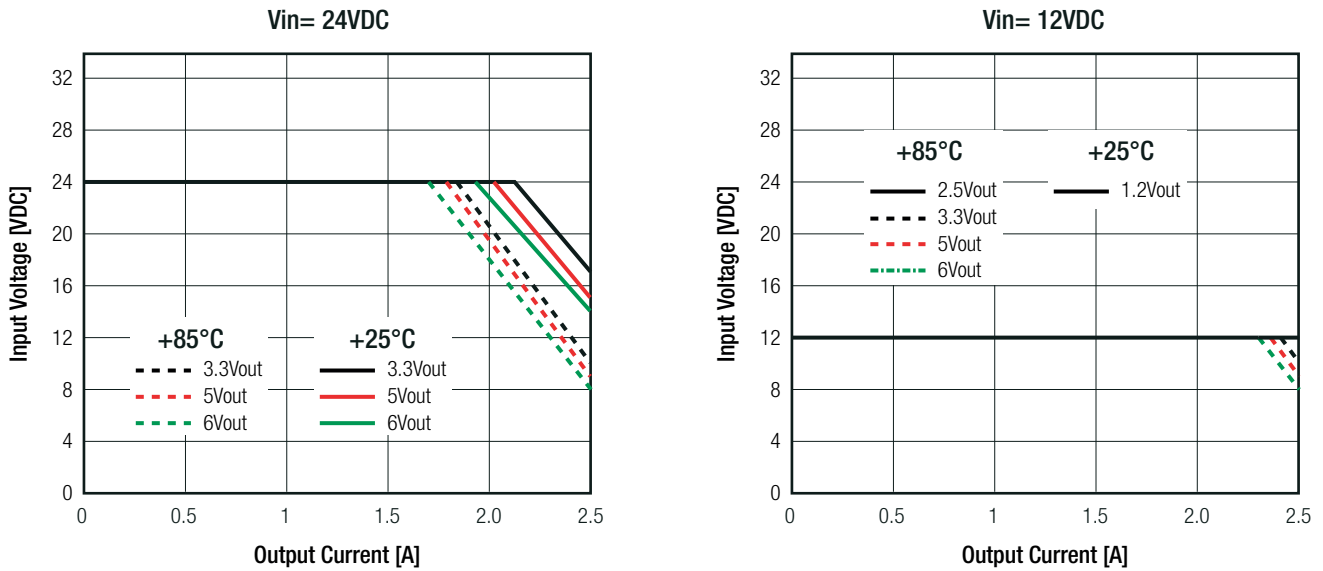

SAFETY AND CERTIFICATIONS

Certificate Type (Safety)	Standard	
RoHS2+	RoHS 2011/65/EU + AM2015/863	
EMC Compliance	Condition	Standard / Criterion
Electromagnetic compatibility of multimedia equipment - Emission requirements	refer to "EMC Filtering"	EN55032, Class B

EMC Filtering suggestions for EN55032

($V_{in} = 12\text{VDC}$; $V_{out} = 5\text{VDC}$; $I_{out} = 2.5\text{A}$)

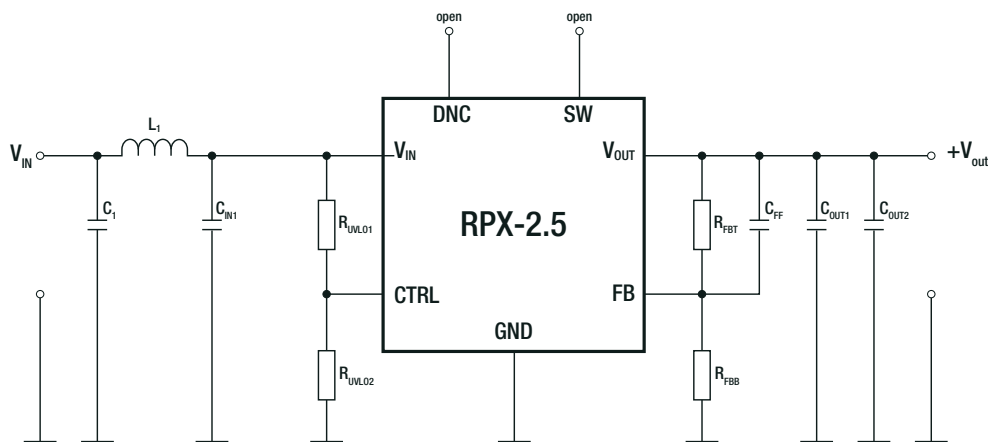

Component List Class B

C1, C_{IN1}	L1	C_{OUT1,2}
10 μF , 50V; X7R 1210	18μH choke RLS-186	47 μF , 10V; X7R 1210

Specifications (measured @ $t_a = 25^\circ\text{C}$, 12V_{in} , 3.3V_{out} , full load and after warm-up unless otherwise stated, refer to test set up)

DIMENSION AND PHYSICAL CHARACTERISTICS

Parameter	Type	Value
Material	case	plastic, UL94 V-0
Dimension (LxWxH)		4.1 x 4.6 x 2.1mm
Weight		107mg typ.

Dimension Drawing (mm)

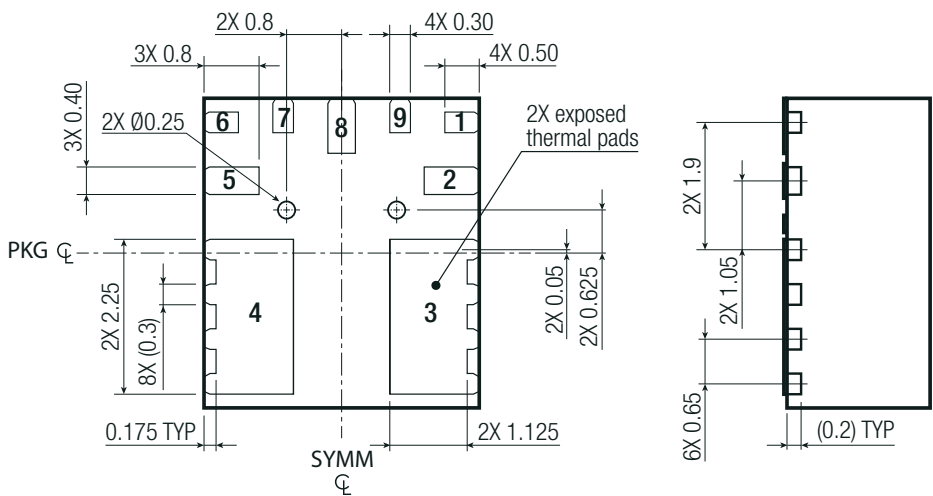
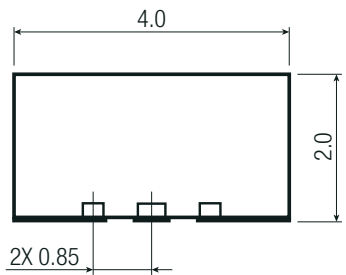
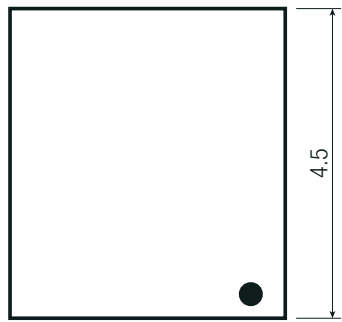
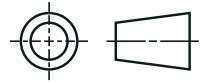

Pad Information

Pad #	Function	Description
1	FB	Feedback Input. Used to set the output voltage between 1.2V and 6V
2	VIN	Input Voltage. Connect external bypass capacitors between this pin and GND close to the pins
3	VOUT	Output Voltage. Connect external bypass capacitors between this pin and GND close to the pins
4, 5	SW	Switch node. Do not connect
6, 7	DNC	Do not connect. Must be soldered to an isolated pad
8	GND	Ground pin. Connect this pin to the power ground plane on the PCB
9	CTRL	CTRL pin. Float this pin when not used

Tolerances: $x.x = \pm 0.1\text{mm}$
 $x.xx / x.xxx = \pm 0.05\text{mm}$

Dimensioning and tolerancing according to ASME Y14.5

continued on next page

Specifications (measured @ $t_a = 25^\circ\text{C}$, 12Vin, 3.3Vout, full load and after warm-up unless otherwise stated, refer to test set up)

Recommended Stencil (Top View)

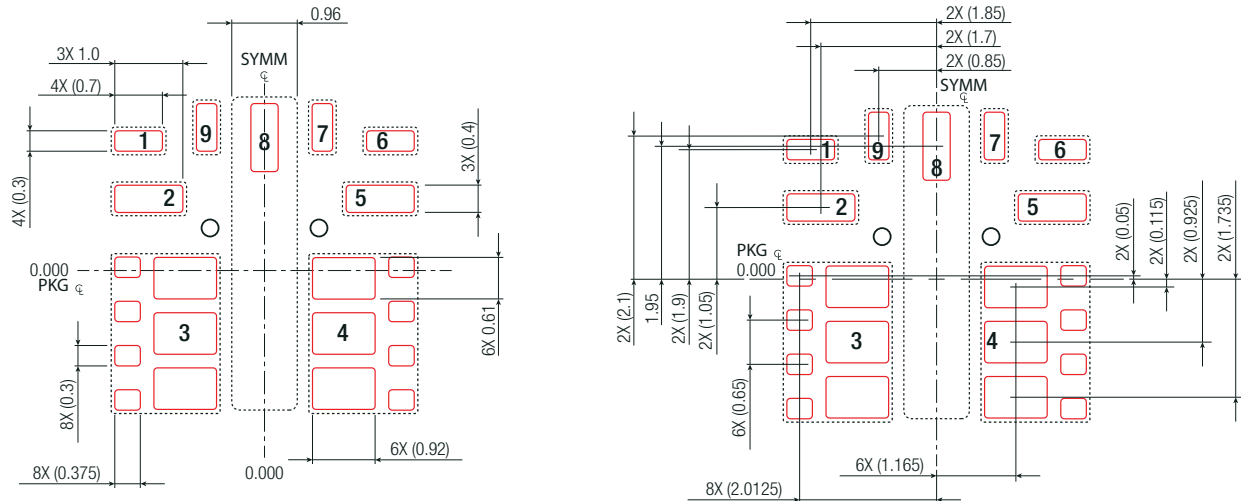

Recommended Footprint Details (Top View)

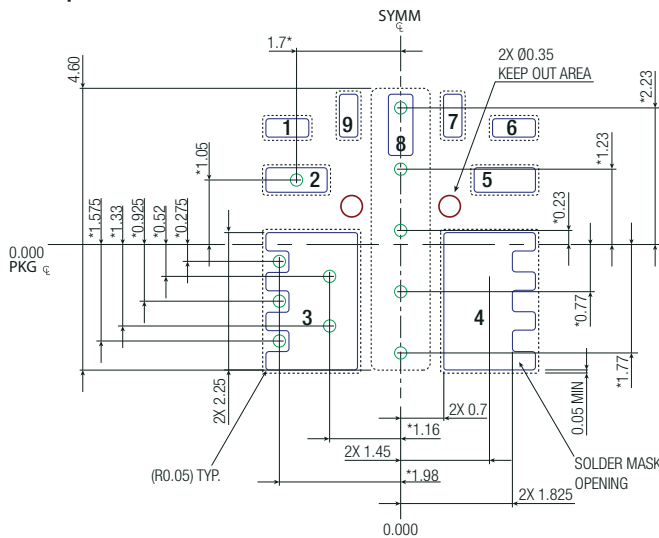

Thermal pads are required to meet full specifications.
*Vias must be filled or plugged for optimum thermal performance.

For more information about the soldering profile, visit our website and download our [App Notes](#).

PACKAGING INFORMATION

Parameter	Type	Value
Packaging Dimension (LxWxH)	reel (diameter + width)	Ø330.0 + 12.4mm height
	tape and reel (carton)	336.0 x 336.0 x 48.0mm
Packaging Quantity	moisture barrier bag ("-CT")	100.0 x 100.0 x 30mm
	tape and reel	250pcs
Tape Width	moisture barrier bag ("-CT")	10pcs
Storage Temperature Range		12mm
Storage Humidity		-55°C to +125°C
ESD Sensitivity Level	non-condensing	95% RH max.
Moisture Sensitivity Level	HBM	Class 2
	JEDEC J-STD-020E	MSL3

The product information and specifications may be subject to changes even without prior written notice. The product has been designed for various applications; its suitability lies in the responsibility of each customer. The products are not authorized for use in safety-critical applications without RECOM's explicit written consent. A safety-critical application is an application where a failure may reasonably be expected to endanger or cause loss of life, inflict bodily harm or damage property. The applicant shall indemnify and hold harmless RECOM, its affiliated companies and its representatives against any damage claims in connection with the unauthorized use of RECOM products in such safety-critical applications.

X-ON Electronics

Largest Supplier of Electrical and Electronic Components

Click to view similar products for [Non-Isolated DC/DC Converters](#) category:

Click to view products by [Recom Power](#) manufacturer:

Other Similar products are found below :

[PSR152.5-7IR](#) [APTH003A0X-SRZ](#) [SPM1004-3V3C](#) [R-785.0-05](#) [10E24-P15-10PPM](#) [1E24-P4-25PPM-SHV-5KV](#) [PROPOWER-3.3V](#)
[MYGTM01210BZN](#) [40C24-N250-I5-H](#) [40A24-P30-E](#) [3V12-P0.8](#) [10C24-N250-I10-AQ-DA](#) [4AA24-P20-M-H](#) [3V12-N0.8](#) [3V24-P1](#) [3V24-](#)
[N1](#) [BMR4672010/001](#) [BMR4652010/001](#) [6AA24-P30-I5-M](#) [6AA24-N30-I5-M](#) [BM2P101X-Z](#) [35A24-P30](#) [2.5M24-P1](#) [PTV03010WAD](#)
[PTV05020WAH](#) [PTV12010LAH](#) [PTV12020WAD](#) [R-7212D](#) [R-7212P](#) [R-78AA15-0.5SMD](#) [R-78AA5.0-1.0SMD](#) [30A24-N15-E](#) [10A12-P4-](#)
[M](#) [10C24-N250-I5](#) [10C24-P125](#) [10C24-P250-I5](#) [6A24-P20-I10-F-M-25PPM](#) [1A24-P30-F-M-C](#) [TSR 1-24150SM](#) [1/2AA24-N30-I10](#) [1C24-](#)
[N125](#) [12C24-N250](#) [V7806-1500](#) [PTV12020LAH](#) [PTV05010WAH](#) [PTN04050CAZT](#) [PTH12020WAD](#) [PTH12020LAS](#) [PTH05050YAH](#)
[PTH05T210WAH](#)