

Features

Reference Design

- 3.3V from a single AA battery (boost converter)
- Efficiency 93%, >80% at 10% load
- Input voltage range down to 0.65V
- 0.100" (2.54mm) pin output
- 3.5mm mounting holes

R-REF02-78S

Description

The R-REF02-78S generates 3.3V from a single AA battery and can directly be used in any application. The reference design contains a AA battery holder and an R-78S3.3-0.1 boost converter. Two jumper headers J1 and J2 ensure connectivity to the output voltage and the CTRL pin of the R-78S converter. The jumper header pins are standard 0.100" (2.54mm) pitch for which there are several mating connectors available. Two 3.5mm mounting holes are provided to allow snap-in or screw mounting. An enable pin puts the R-78S into sleep-mode where it draws only 7uA from the battery.

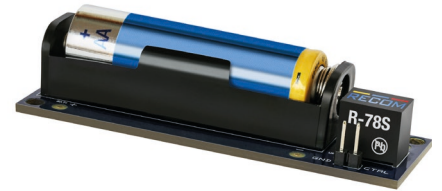

Selection Guide

Part Number	Input Voltage Range ⁽³⁾ [VDC]	Output Voltage [VDC]	Output Current [mA]	Efficiency ⁽¹⁾		Max. Capacitive Load ⁽²⁾ [μF]
				@ min Vin [%]	@ typ. Vin [%]	
R-78S3.3-0.1	0.65-3.15	3.3	100	92	93	470

Specifications (measured @ ta= 25°C, 1.5Vin, full load after warm up unless otherwise stated)

BASIC CHARACTERISTICS				
Parameter	Condition	Min.	Typ.	Max.
Under Voltage Lockout	DC-DC OFF		0.4VDC	
Overload Capability ⁽³⁾	peak duty cycle 10%		150%, 10s	
Quiescent Current			160μA	
Start-up Time			2ms	
Rise Time			800μs	
Internal Operating Frequency			1200kHz	
Minimum Load		0%		
Dropout Voltage			150mV	
Output Ripple and Noise			100mVp-p	
ON/OFF CTRL	DC-DC ON DC-DC OFF		Open or $0.7V \leq V_{CTRL} < V_{in}$ Short to GND or $V_{CTRL} < 0.1V$	
Input Current of CTRL Pin			5μA	
Standby Current			7μA	

Notes:

Note1: Efficiency is tested at full load. Typ. Vin = 1.5V

Note2: Max. capacitive load is tested at nominal input and full resistive load

Note3: For more information, please refer to "Overload Capability Graph" on page P-2



Caution:

ESD sensitive. Always follow ESD preventative procedures when handling the product!

Specifications (measured @ $t_a = 25^\circ\text{C}$, 1.5Vin, full load after warm up unless otherwise stated)

Overload Capability Graph

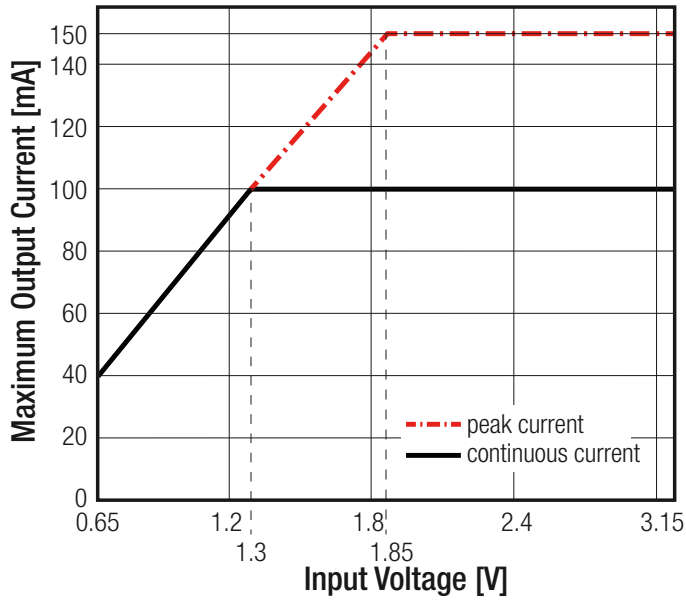

Quick Start Guide

- Insert the AA battery into the battery holder (only one way possible).
- The output voltage is accessed via J1.
- To set the R-78S into sleep mode, short both pins of J2 (CTRL to GND).

Component Placement

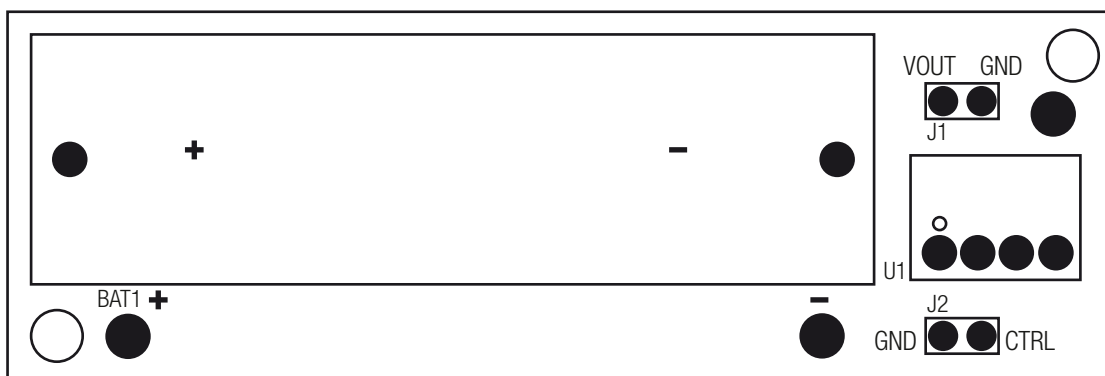

Component List

Part	Description
BAT1	AA battery holder
U1	R-78S3.3-0.1
J1	2 pin 0.100" (2.54mm) header for VOUT and GND
J2	2 pin 0.100" (2.54mm) header for CTRL and GND

Specifications (measured @ $t_a = 25^\circ\text{C}$, 1.5V_{in}, full load after warm up unless otherwise stated)

Schematic

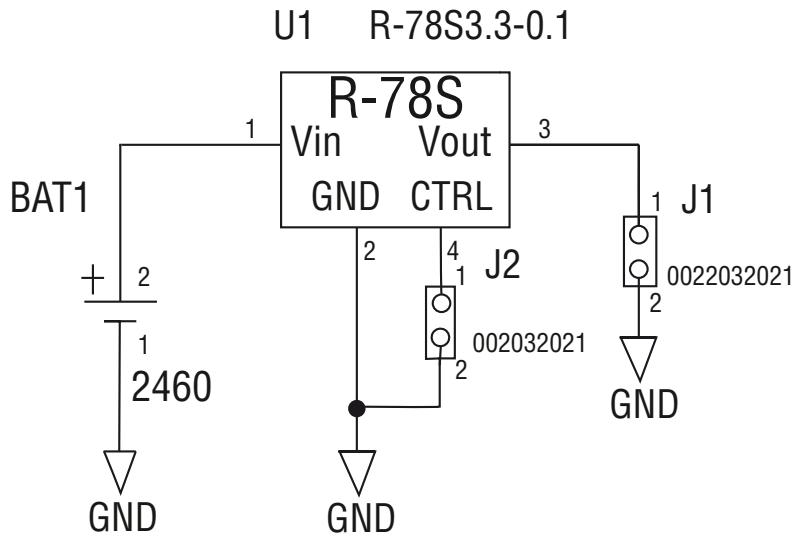

DIMENSION AND PHYSICAL CHARACTERISTICS

Parameter	Type	Value
Dimension (LxWxH)		75.0 x 25.0 x 17.5mm
Weight		12.1g typ.

Layout

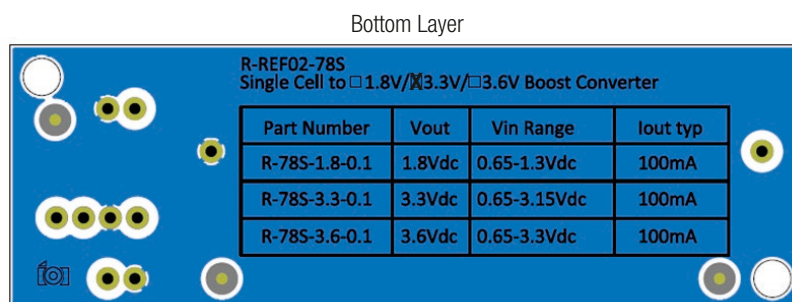
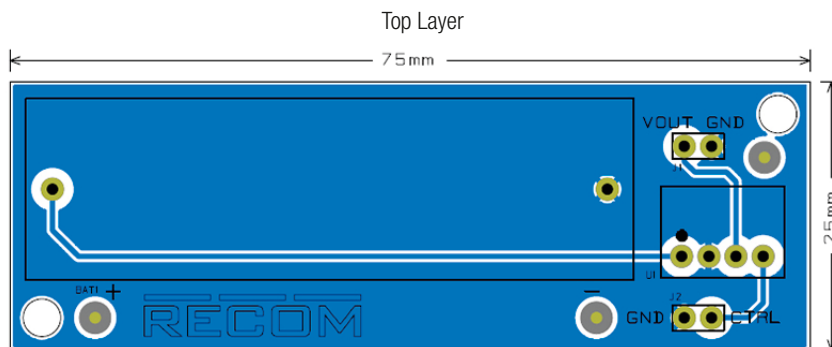

Specifications (measured @ ta= 25°C, 1.5Vin, full load after warm up unless otherwise stated)

BOM

Part Name/Number	Description	Manufacturer Part Number	Manufacturer	Qty.	Comps.
BATTERY HOLDER_AA	Holder Battery 1Cell AA PCB MNT	2460	Keystone Electronics	1	BAT1
JUMPER_2PINS	2 Position Header Connector 0.100" (2.54mm) Through Hole Tin	0022032021	Molex	2	J1 J2
R-78S3.3-0.1	DC DC Converter 3.3V	R-78S3.3-0.1	RECOM	1	U1

PACKAGING INFORMATION

Parameter	Type	Value
Packaging Dimension (LxWxH)	airbag	177.0 x 126.0 x 25.0mm
Packaging Quantity		1pcs

The product information and specifications may be subject to changes even without prior written notice. The product has been designed for various applications; its suitability lies in the responsibility of each customer. The products are not authorized for use in safety-critical applications without RECOM's explicit written consent. A safety-critical application is an application where a failure may reasonably be expected to endanger or cause loss of life, inflict bodily harm or damage property. The applicant shall indemnify and hold harmless RECOM, its affiliated companies and its representatives against any damage claims in connection with the unauthorized use of RECOM products in such safety-critical applications.

X-ON Electronics

Largest Supplier of Electrical and Electronic Components

Click to view similar products for [Power Management IC Development Tools](#) category:

Click to view products by [Recom Power](#) manufacturer:

Other Similar products are found below :

[EVAL-ADM1168LQEBZ](#) [EVB-EP5348UI](#) [MIC23451-AAAYFL EV](#) [MIC5281YMME EV](#) [DA9063-EVAL](#) [ADP122-3.3-EVALZ](#) [ADP130-0.8-EVALZ](#) [ADP130-1.2-EVALZ](#) [ADP130-1.5-EVALZ](#) [ADP130-1.8-EVALZ](#) [ADP1714-3.3-EVALZ](#) [ADP1716-2.5-EVALZ](#) [ADP1740-1.5-EVALZ](#) [ADP1752-1.5-EVALZ](#) [ADP1828LC-EVALZ](#) [ADP1870-0.3-EVALZ](#) [ADP1871-0.6-EVALZ](#) [ADP1873-0.6-EVALZ](#) [ADP1874-0.3-EVALZ](#) [ADP1882-1.0-EVALZ](#) [ADP199CB-EVALZ](#) [ADP2102-1.25-EVALZ](#) [ADP2102-1.875EVALZ](#) [ADP2102-1.8-EVALZ](#) [ADP2102-2-EVALZ](#) [ADP2102-3-EVALZ](#) [ADP2102-4-EVALZ](#) [ADP2106-1.8-EVALZ](#) [ADP2147CB-110EVALZ](#) [AS3606-DB](#) [BQ24010EVM](#) [BQ24075TEVM](#) [BQ24155EVM](#) [BQ24157EVM-697](#) [BQ24160EVM-742](#) [BQ24296MEVM-655](#) [BQ25010EVM](#) [BQ3055EVM](#) [NCV891330PD50GEVB](#) [ISLUSBI2CKIT1Z](#) [LM2744EVAL](#) [LM2854EVAL](#) [LM3658SD-AEV/NOPB](#) [LM3658SDEV/NOPB](#) [LM3691TL-1.8EV/NOPB](#) [LM4510SDEV/NOPB](#) [LM5033SD-EVAL](#) [LP38512TS-1.8EV](#) [EVAL-ADM1186-1MBZ](#) [EVAL-ADM1186-2MBZ](#)