

# Features

# Reference Design

- Evaluation platform for railway DC/DC converters up to 240W with either high voltage (-1) or high current (-2) layouts
- Includes RIA12 surge stopper with reverse polarity protection
- On-board EN50121-3-2 EMC filter layout
- Suitable for 2"x1", quarter brick or half brick converters
- External hold-up capacitor
- Cage clamp terminals, isolated enable and fan connectors

## R-REF04-RIA12

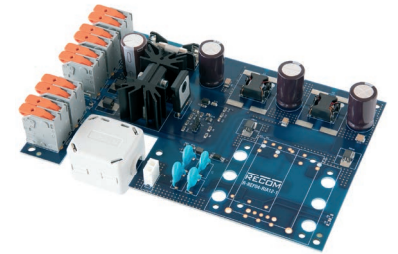

### Selection Guide

Part Number	Input Voltage Range [VDC]	Input Current max. [A]	Output Current max. [A]
R-REF04-RIA12-1	40 - 160	3.8	45
R-REF04-RIA12-2	12 - 75	10	45

### Description

The R-REF04-RIA12-1 and R-REF04-RIA12-2 are complete reference designs for railway applications. R-REF04-RIA12-1 is populated with components rated for higher DC input voltages up to 110VDC nominal input; the R-REF04-RIA12-2 is populated with components rated for higher DC input currents up to 10A. Both boards are input side fused and can be used with DC/DC converters with single output currents up to 45A. The reference designs include a RIA12-conform surge stopper capable of blocking surge voltages up to 385VDC.

The reference design has a universal pinout to accommodate DC/DC converters with 2"x1", Quarter Brick or Half Brick standard case dimensions (sold separately).

The following converters are suitable:

Converter Series	nom. Input Voltage [VDC]	Output Voltage [VDC]	Case Dimension	Recommended Reference Design
RP40-FR	24	3.3, 5, 12, 15, 24	2" x 1"	R-REF04-RIA-2
	48, 110			R-REF04-RIA-1
RPA60-FW	24	5, 12, 15, 24	2" x 1"	R-REF04-RIA-2
RP75H-RW	24	3.3, 5, 12, 15, 24	Half Brick	R-REF04-RIA-2
	48, 110			R-REF04-RIA-1
RP40Q-RUW	16 - 160	5, 12, 15, 24, 48	Quarter Brick	R-REF04-RIA-1
RP60Q-RUW	16 - 160	5, 12, 15, 24, 48	Quarter Brick	R-REF04-RIA-1
RP90Q-RW	24	5, 12, 15, 24, 48	Quarter Brick	R-REF04-RIA-2
	48, 110			R-REF04-RIA-1
RP100H-RW	24	5, 12, 15, 24, 48	Half Brick	R-REF04-RIA-2
	48, 110			R-REF04-RIA-1
RP120Q-RW	24	5, 12, 15, 24, 48	Quarter Brick	R-REF04-RIA-2
	48, 110			R-REF04-RIA-1
RP180H-RW	24	5, 12, 15, 24, 48	Half Brick	R-REF04-RIA-2
	48, 110			R-REF04-RIA-1
RP240H-RW	24	5, 12, 15, 24, 48	Half Brick	R-REF04-RIA-2
	48, 110			R-REF04-RIA-1



#### Caution:

ESD sensitive. Always follow ESD preventative procedures when handling the product!

## Specifications (measured @ Ta= 25°C, full load after warm up unless otherwise stated)

### Quick Start Guide

1. Fit the appropriate DC/DC converter (mounting holes are provided for fixing screws) on to the board. Carefully solder the pins, checking that the solder connections are clean and there are no dry joints
2. If required, mount a suitable cooling fan (supply voltage = DC/DC output voltage) and connect to the fan supply connector, CON6
3. If necessary, connect an external hold-up capacitor using CON4

The required total hold-up capacitance can be calculated from the following relationship:

$$C_{\text{hold-up}} = \frac{200 \times P_{\text{out}} \times t_{\text{hold-up}}}{1000 \times \eta_{\text{full load}} \times (V_{\text{in nom.}}^2 - V_{\text{in min.}}^2)}$$

$C_{\text{hold-up}}$	= total hold-up capacitance	[ $\mu\text{F}$ ]
$P_{\text{out}}$	= output power	[W]
$t_{\text{hold-up}}$	= required hold-up time	[ms]
$\eta_{\text{full load}}$	= efficiency of converter (from datasheet)	[%]
$V_{\text{in nom.}}$	= nom. input voltage	[V]
$V_{\text{in min.}}$	= min. operating input voltage of converter (from datasheet)	[V]

### Examples:

1: For a 10ms hold-up time for **RPA120-11024SW** (120W, 110VDC input, 24VDC output) **R-REF04-RIA12-1** is used:

$P_{\text{out}} = 120\text{W}$	$C_{\text{hold-up}} = \frac{200 \times 120 \times 10}{1000 \times 88.5 \times (110^2 - 53^2)}$
$t_{\text{hold-up}} = 10\text{ms}$	
$\eta_{\text{full load}} = 88.5\%$	
$V_{\text{in nom.}} = 110\text{V}$	
$V_{\text{in min.}} = 53\text{V}$	
	$C_{\text{hold-up}} = \underline{292\mu\text{F}}$

No external hold-up capacitor is required (450 $\mu\text{F}$  is on-board)

2: For a 30ms hold-up time for **RP180-2415SW** (144W, 24VDC input, 15VDC output) **R-REF04-RIA12-2** is used:

$P_{\text{out}} = 144\text{W}$	$C_{\text{hold-up}} = \frac{200 \times 144 \times 30}{1000 \times 90 \times (24^2 - 9^2)}$
$t_{\text{hold-up}} = 30\text{ms}$	
$\eta_{\text{full load}} = 90\%$	
$V_{\text{in nom.}} = 24\text{V}$	
$V_{\text{in min.}} = 9\text{V}$	
	$C_{\text{hold-up}} = \underline{19400\mu\text{F}}$

A 18000 $\mu\text{F}$  external hold-up capacitor bank is required (1410 $\mu\text{F}$  is on-board)

4. Connect the supply voltage to CON1 and, if necessary, enable the device via CON5 (/N versions are normally on if EN is left floating)

Specifications (measured @ Ta= 25°C, full load after warm up unless otherwise stated)

## Schematic

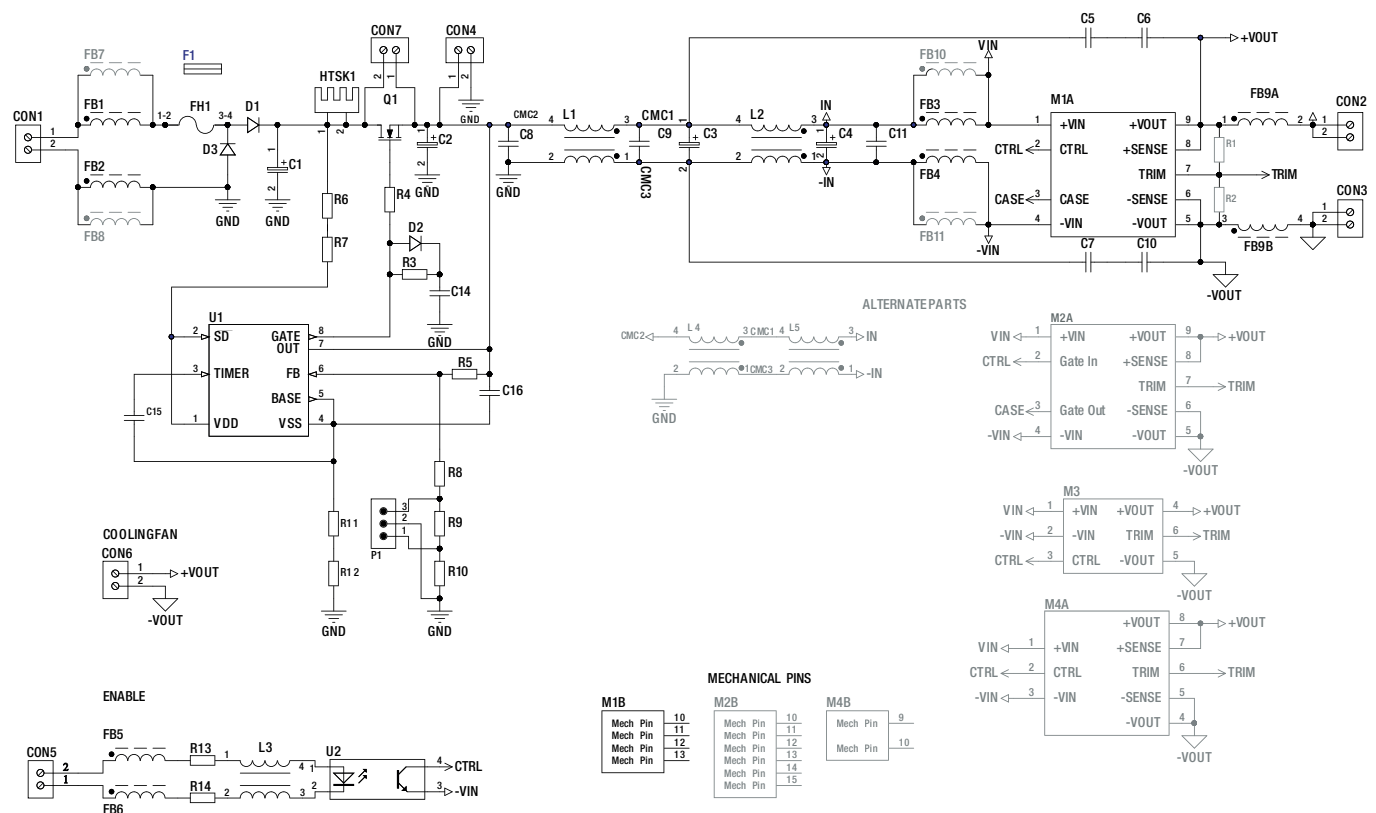

Grey coloured parts are alternate parts

## Description

CON1 is the input voltage connector

D3 will blow fuse F1 if a reverse voltage is applied

D1 supports the hold-up circuit if the input is short circuited

U1 together with Q1 and the corresponding surge blocker circuit clamps RIA12 surge over voltages

CON 7 allows the surge blocker circuit to be bridged. This is useful for lower input voltages where a surge blocking function is not needed and allows the power dissipation in Q1 to be eliminated

CON4 is the external hold-up capacitor connector for longer hold-up times (refer to previous section)

CON5 is an opto-coupler isolated enable input. Enable signals can be referenced to -Vin or +Vin, or supplied from an independently powered external circuit (refer to next section)

CON6 is a connector across the DC output used to power a cooling fan

R1 and R2 allow trimming of the output voltage of the converter if required

CON2 and CON3 are the connectors for the output voltage. They are paralleled for high output currents

L1, L2, FB1, FB2, FB3, FB4, FB9, C1, C3, C5, C6, C7, C8, C9 and C10 form the EN50121-3-2 EMC filter

**Specifications** (measured @ Ta= 25°C, full load after warm up unless otherwise stated)

**Background to RIA12 Requirements**

The R-REF04-RIA12 reference designs include a RIA12-conform surge stopper circuit. RIA12 is a legacy railway standard that precedes the current EN50155 standard, but is still relevant for older rail installations. The maximum surge voltage according to RIA12 is 3.5x the nominal input voltage, much higher than the EN50155 limit of 1.4x the nominal input voltage. Due to the very low source impedance and relatively long duration of 20ms, RIA12 surges cannot be easily blocked with an input filter. An active input voltage clamp is required, which has been incorporated in the R-REF04-RIA12 reference design.

The surge voltages are defined in the RIA Specification No 12:

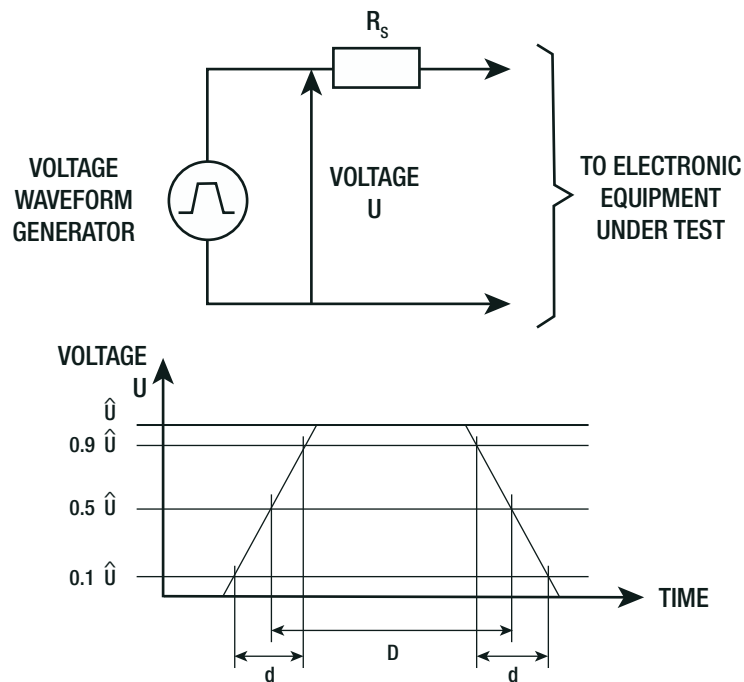

Wave Form	Type of Disturbance	Voltage Level U (minimum)	Duration d (Maximum)	Duration D (Minimum)	Series Resistor Rs (±10% Tolerance)
A	Supply Related Surge	$3.5 \times V_{nom.}$	2.0ms	20ms	$0.2\Omega$
B		$1.5 \times V_{nom.}$	0.1s	1.0s	$0.2\Omega$
C	Direct Transient	800V	10µs	100µs	5Ω
D		1500V	5µs	50µs	5Ω
E		3000V	0.5µs	5µs	100Ω
F		4000V	0.1µs	1µs	100Ω
G		7000V	0.05µs	0.1µs	100Ω
H	Indirect Coupled Transient	1500V	5µs	50µs	100Ω
J		3000V	0.5µs	5µs	100Ω
K		4000V	0.1µs	1µs	100Ω
L		7000V	0.05µs	0.1µs	100Ω

$V_{nom.}$  = nominal Voltage

**Specifications** (measured @ Ta= 25°C, full load after warm up unless otherwise stated)

### Surge Stopper Function

The converters are protected from high surge voltages with a clamp circuit based on LTC4366 surge stopper IC.

#### Voltage Clamping:

In normal operation, Q1 is forward biased. So the input voltage of the converter is almost equal to the input voltage at CON1 (minus the diode voltage drop of D1). In the case of a surge event on the input, Q1 enters linear operation and clamps the voltage to a level which is preset by the potential divider resistor chain R5 and R8 + R9 + R10.

#### Maximum Clamping Time:

The maximum clamping time is set by C15. It is preset to 30ms. The time is related to capacitance by 311ms/μF. After this time the IC shuts down Q1 to prevent thermal damage to of Q1. After 9 seconds cool down period, U1 and Q1 enter normal operation again. Before increasing the clamp time, always check the safe operating area of Q1.

The following clamp voltages are preset by jumpers on the board:

Part Number	No Jumper set	Jumper 1-2	Jumper 2-3
R-REF04-RIA12-1	160V	154V	103V
R-REF04-RIA12-2	75V	70V	36V

The clamp voltage can be adjusted to other levels by changing the resistor chain using the following equation:

$$V_{clamp} = (R8 + R9 + R10) \times 101.6\mu A + 1.23V$$

#### Inrush Current Limiter:

The clamp circuit also functions as an inrush current limiter for the on-board and off-board hold-up capacitors. It is not a classical inrush current limiter, but rather a controlled ramp up of the capacitor voltage. Capacitor C14 is charged with a constant current of 20μA, so the voltage ramps up linearly. The output voltage to the hold-up and filter capacitors tracks the voltage across C14. The voltage rise time is given by the following equation:

$$\frac{\Delta V}{\Delta t} = \frac{20\mu A}{C_{C14}}$$

C14 is populated with a 2n2 capacitor to give a voltage rise time ( $t_{Vrise}$ ) of 9V/ms. The inrush current can be calculated using:

$$I_{Inrush} = C \times t_{Vrise}$$

The R-REF04-RIA12-1 has 3 x 150μF electrolytic caps fitted, so C = 450μF

$$I_{Inrush} = 450 \times 9V/ms = \underline{4A}$$

The R-REF04-RIA12-2 has 3 x 470μF electrolytic caps fitted, so C = 1410μF

$$I_{Inrush} = 1410 \times 9V/ms = \underline{12.7A}$$

If external hold-up capacitance is added, the inrush current will increase proportionally. If the inrush current exceeds the supply capability, then C14 should be increased to increase  $t_{Vrise}$ .

Note: The current into C1 is not limited with this circuit.

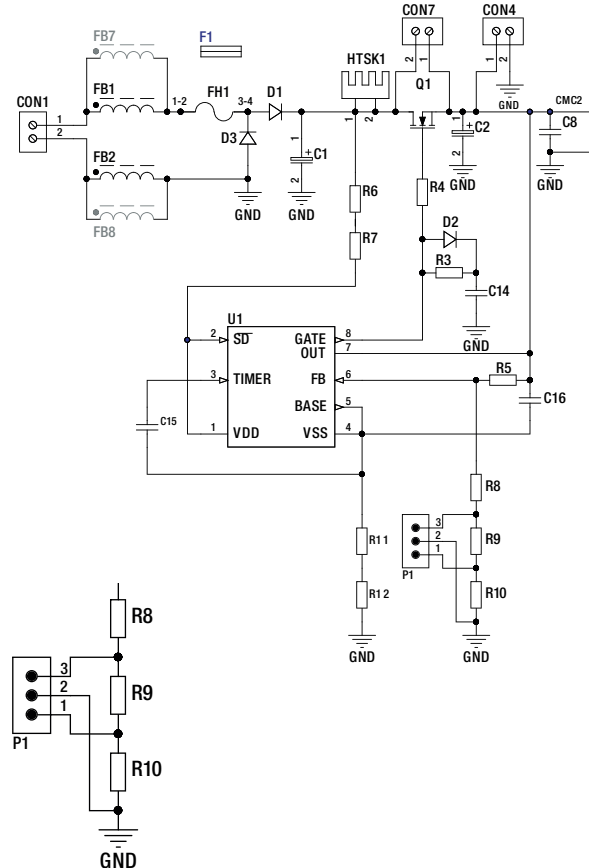

Specifications (measured @ Ta= 25°C, full load after warm up unless otherwise stated)

## Component Placement

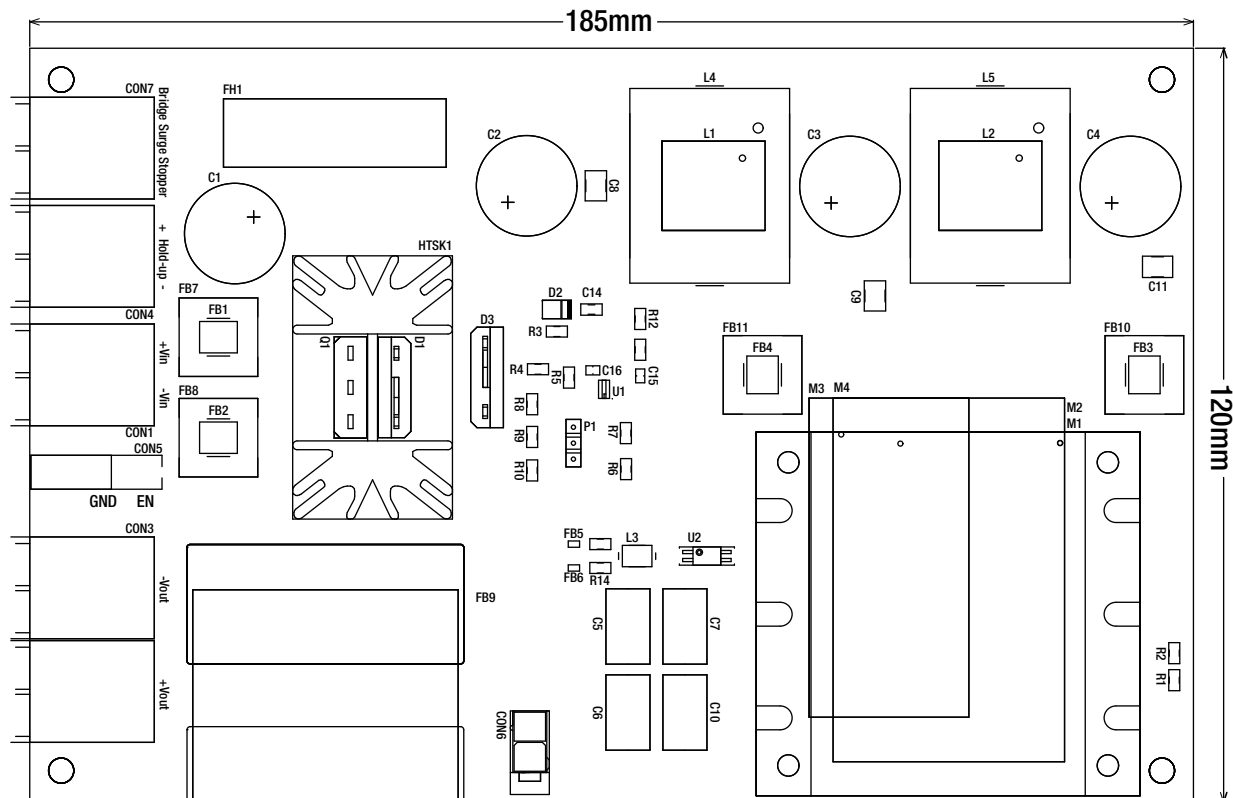

## Connector Description

CON	Name	Description
CON7	Bridge Surge Stopper	Link with a wire to bypass the surge stopper FET
CON1	+Vin	Positive input voltage (Reverse polarity protected, RIA12 surge stopper active)
	-Vin	Negative input voltage (Reverse polarity protected, RIA12 surge stopper active)
CON3	-Vout	Negative output voltage
	-Vout	

CON	Name	Description
CON4	+Hold-up	External hold-up capacitor positive terminal
	-Hold-up	External hold-up capacitor negative terminal
CON5	EN	Enable input (floating)
	GND	GND
CON6	+Fan	Positive output fan supply
	-Fan	Negative output fan supply
CON2	+Vout	Positive output voltage
	+Vout	

**Specifications** (measured @ Ta= 25°C, full load after warm up unless otherwise stated)

**Enable Schematic**

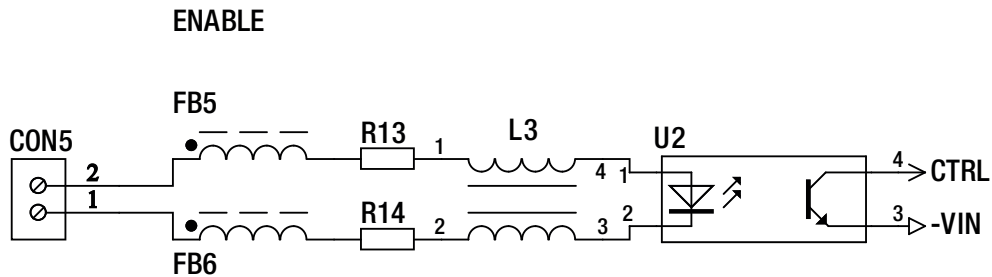

**Description**

CON5 is used to enable or disable the device. Which control logic is used, depends on converter chosen:

Positive logic:

Converter is preset to be enabled (ON).

A voltage on CON5 disables the converter.

Negative logic:

Converter is preset to be disabled (OFF).

A voltage on CON5 enables the converter.

A positive voltage of between 5V and 15V enables (positive logic) or disables (negative logic) the converter. This is based on an output sink current of 3mA on the CTRL Pin which is suitable for the most converters. If higher currents are required, an adjustment of R13 and R14 may be required.

Output Trim:

R1 and R2 are unpopulated pads to allow external output voltage trimming resistors to be added.

Refer to the converter datasheets for the appropriate resistor values.

**DIMENSION AND PHYSICAL CHARACTERISTICS**

Parameter	Type	Value
Dimension (LxWxH)		185.0 x 120.0 x 45.0mm
Weight		295g typ.

**Layout**

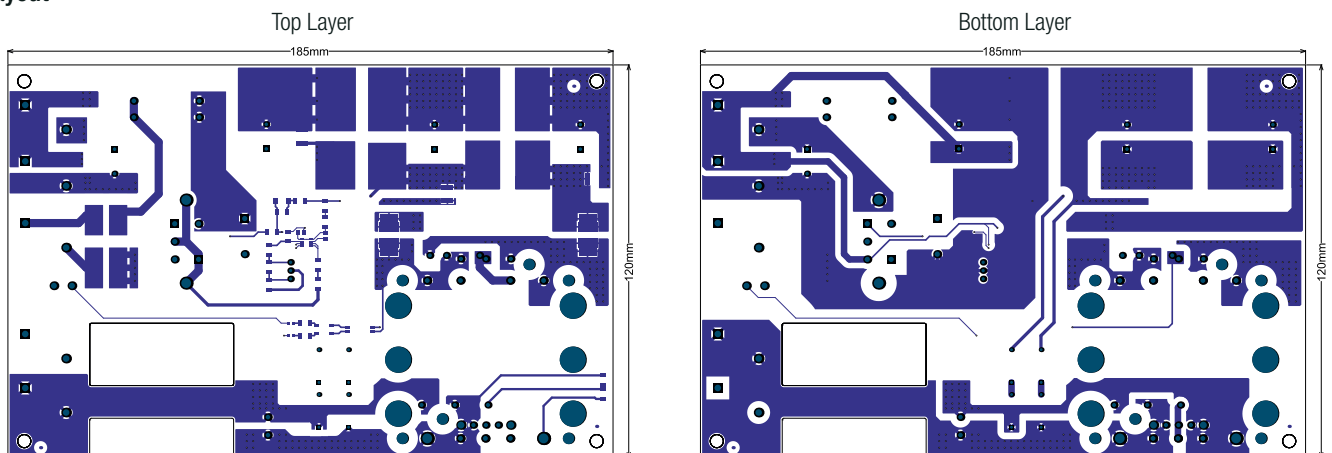

**Notes:**

Note1: visit [www.recom-power.com/eval-ref-boards](http://www.recom-power.com/eval-ref-boards) to download the Gerber files

**Specifications** (measured @ Ta= 25°C, full load after warm up unless otherwise stated)

**BOM: R-REF04-RIA12-1**

Comp.	Description	Manufacturer	Manufacturer Part Number	Remarks
F1	FUSE-0ADKC9160-BE	BEL FUSE	0ADKC9160-BE	insert to Fuse Holder
FB9	IND_BEAD_74271221	WURTH	74271221	not mounted
C8	CC2-1U200VX7R-1812	VENKEL	C1812X7R201-105KNE	
C9	CC2-1U200VX7R-1812	VENKEL	C1812X7R201-105KNE	
C11	CC2-1U200VX7R-1812	VENKEL	C1812X7R201-105KNE	
C14	CC2-2N2KVX7R-1206	MURATA	GRM31BR73A222KW01L	
C15	CC2-10N50VX7R-0805	SAMSUNG ELECTRO-MECHANICS	CL21B103KBANNNC	
C16	CC2-470N50VX7R-0805	MURATA	GCM21BR71H474KA55L	
D2	STTH1R06A	STMICROELECTRONICS	STTH1R06A	
FB1	IND-BEAD-7427511	WURTH	7427511	
FB2	IND-BEAD-7427511	WURTH	7427511	
FB3	IND-BEAD-7427511	WURTH	7427511	
FB4	IND-BEAD-7427511	WURTH	7427511	
FB5	IND_BEAD_742792651	WURTH	742792651	
FB6	IND_BEAD_742792651	WURTH	742792651	
FB7	IND_BEAD_742792901	WURTH	742792901	not mounted
FB8	IND_BEAD_742792901	WURTH	742792901	not mounted
FB10	IND_BEAD_742792901	WURTH	742792901	not mounted
FB11	IND_BEAD_742792901	WURTH	742792901	not mounted
FD1	FIDUCIAL_1MM			
FD2	FIDUCIAL_1MM			
FD3	FIDUCIAL_1MM			
L1	IND-INPUT-PA2749NL	PULSE ELECTRONICS	PA2749NL	
L2	IND-INPUT-PA2749NL	PULSE ELECTRONICS	PA2749NL	
L3	IND-INPUT-PE-1812ACC110STS	PULSE ELECTRONICS	PE-1812ACC110STS	
L4	IND-INPUT-PA2670NL	PULSE ELECTRONICS	PA2670NL	not mounted
L5	IND-INPUT-PA2670NL	PULSE ELECTRONICS	PA2670NL	not mounted
R1	RES-750K-1206	VISHAY	CRCW1206750KFKEA	not mounted
R2	RES-750K-1206	VISHAY	CRCW1206750KFKEA	not mounted
R3	RES-1K-1206	VISHAY	CRCW12061K00FKEAC	
R4	RES-10R-1206	VISHAY	CRCW120610R0FKEAC	
R5	RES-12K1-1206	VISHAY	CRCW120612K1FKEA	
R6	RES-750K-1206	VISHAY	CRCW1206750KFKEA	
R7	RES-750K-1206	VISHAY	CRCW1206750KFKEA	
R8	RES-1M-1206	SAMSUNG ELECTRO-MECHANICS	RC3216F1004CS	
R9	RES-499K-1206	SAMSUNG ELECTRO-MECHANICS	RC3216F4993CS	
R10	RES-62K-1206	SAMSUNG ELECTRO-MECHANICS	RC3216F623CS	
R11	RES-68K-1206	VISHAY	CRCW120668K0FKEA	
R12	RES-68K-1206	VISHAY	CRCW120668K0FKEA	
R13	RES-510R-1206	VISHAY	CRCW1206510RFKEA	
R14	RES-510R-1206	VISHAY	CRCW1206510RFKEA	
U1	LTC4366MPTS8-2	ANALOG DEVICES	LTC4366MPTS8-2#TRMPBF	

continued on next page



**Specifications** (measured @ Ta= 25°C, full load after warm up unless otherwise stated)

Comp.	Description	Manufacturer	Manufacturer Part Number	Remarks
U2	OPTO_VOS617A-3X001T	VISHAY	VOS617A-3X001T	
C1	CAEMR-68U400V-16x26.5	NICHICON	UCY2G680MHD9TN	
C2	CAEMR-150U200V-16x26.5	NICHICON	UCS2D151MHD	
C3	CAEMR-150U200V-16x26.5	NICHICON	UCS2D151MHD	
C4	CAEMR-150U200V-16x26.5	NICHICON	UCS2D151MHD	
C5	CX1Y1-4N7250V-DE1E3KX472MA4BN01F	MURATA	DE1E3KX472MA4BN01F	
C6	CX1Y1-4N7250V-DE1E3KX472MA4BN01F	MURATA	DE1E3KX472MA4BN01F	
C7	CX1Y1-4N7250V-DE1E3KX472MA4BN01F	MURATA	DE1E3KX472MA4BN01F	
C10	CX1Y1-4N7250V-DE1E3KX472MA4BN01F	MURATA	DE1E3KX472MA4BN01F	
CON1	CONN-2P1R-691404910002B	WURTH	691404910002B	
CON2	CONN-2P1R-691404910002B	WURTH	691404910002B	
CON3	CONN-2P1R-691404910002B	WURTH	691404910002B	
CON4	CONN-2P1R-691404910002B	WURTH	691404910002B	
CON5	CONN-2P1R_64900229522	WURTH	64900229522	
CON6	CONN-2P1R_64900221122	WURTH	64900221122	
CON7	CONN-2P1R-691404910002B	WURTH	691404910002B	
D1	SDUR3040W	SMC DIODES SOLUTIONS	SDUR3040W	
D3	SDUR3040W	SMC DIODES SOLUTIONS	SDUR3040W	
FH1	FUSEHOLDER-0031.8231	SCHURTER	0031.8231	
HTSK1	HTSK_529702B02500G	AAVID THERMALLOY	529702B02500G	
M1	RP240H-11024SRW	RECOM	RP240H-11024SRW	not mounted
M2	RPA120H-11024SRW	RECOM	RPA120H-11024SRW	not mounted
M3	RP40-11024SFR	RECOM	RP40-11024SFR	not mounted
M4	RP90Q-11024SRW/N	RECOM	RP90Q-11024SRW/N	not mounted
P1	CONN-3P1R-22032031	MOLEX	22-03-2031	
Q1	IXTH40N50L2	IXYS	IXTH40N50L2	
FD4	FIDUCIAL_1MM			
FD5	FIDUCIAL_1MM			
FD6	FIDUCIAL_1MM			

**BOM: R-REF04-RIA12-2**

Comp.	Description	Manufacturer	Manufacturer Part Number	Remarks
F1	FUSE-0ADKC9160-BE	BEL FUSE	0ADKC9160-BE	
FB9	IND_BEAD_74271221	WURTH	74271221	not mounted
C8	CC2-1U200VX7R-1812	VENKEL	C1812X7R201-105KNE	
C9	CC2-1U200VX7R-1812	VENKEL	C1812X7R201-105KNE	
C11	CC2-1U200VX7R-1812	VENKEL	C1812X7R201-105KNE	
C14	CC2-2N21KVX7R-1206	MURATA	GRM31BR73A222KW01L	
C15	CC2-10N50VX7R-0805	SAMSUNG ELECTRO-MECHANICS	CL21B103KBANNNC	
C16	CC2-470N50VX7R-0805	MURATA	GCM21BR71H474KA55L	

continued on next page

**Specifications** (measured @ Ta= 25°C, full load after warm up unless otherwise stated)

Comp.	Description	Manufacturer	Manufacturer Part Number	Remarks
D2	STTH1R06A	STMICROELECTRONICS	STTH1R06A	
FB1	IND-BEAD-7427511	WURTH	7427511	not mounted
FB2	IND-BEAD-7427511	WURTH	7427511	not mounted
FB3	IND-BEAD-7427511	WURTH	7427511	not mounted
FB4	IND-BEAD-7427511	WURTH	7427511	not mounted
FB5	IND_BEAD_742792651	WURTH	742792651	
FB6	IND_BEAD_742792651	WURTH	742792651	
FB7	IND_BEAD_742792901	WURTH	742792901	
FB8	IND_BEAD_742792901	WURTH	742792901	
FB10	IND_BEAD_742792901	WURTH	742792901	
FB11	IND_BEAD_742792901	WURTH	742792901	
FD1	FIDUCIAL_1MM			
FD2	FIDUCIAL_1MM			
FD3	FIDUCIAL_1MM			
L1	IND-INPUT-PA2749NL	PULSE ELECTRONICS	PA2749NL	not mounted
L2	IND-INPUT-PA2749NL	PULSE ELECTRONICS	PA2749NL	not mounted
L3	IND-INPUT-PE-1812ACC110STS	PULSE ELECTRONICS	PE-1812ACC110STS	
L4	IND-INPUT-PA2670NL	PULSE ELECTRONICS	PA2670NL	
L5	IND-INPUT-PA2670NL	PULSE ELECTRONICS	PA2670NL	
R1	RES-750K-1206	VISHAY	CRCW1206750KFKEA	not mounted
R2	RES-750K-1206	VISHAY	CRCW1206750KFKEA	not mounted
R3	RES-1K-1206	VISHAY	CRCW12061K00FKEAC	
R4	RES-10R-1206	VISHAY	CRCW120610R0FKEAC	
R5	RES-12K1-1206	VISHAY	CRCW120612K1FKEA	
R6	RES-47K-1206	VISHAY	CRCW120647KFKEA	
R7	RES-33K-1206	VISHAY	CRCW120633KFKEA	
R8	RES-340K-1206	SAMSUNG ELECTRO-MECHANICS	RC3216F3403CS	
R9	RES-340K-1206	SAMSUNG ELECTRO-MECHANICS	RC3216F3403CS	
R10	RES-47K-1206	SAMSUNG ELECTRO-MECHANICS	RC3216F473CS	
R11	RES-10K-1206	VISHAY	CRCW120610K0FKEA	
R12	RES-10K-1206	VISHAY	CRCW120610K0FKEA	
R13	RES-510R-1206	VISHAY	CRCW1206510RFKEA	
R14	RES-510R-1206	VISHAY	CRCW1206510RFKEA	
U1	LTC4366MPTS8-2	ANALOG DEVICES	LTC4366MPTS8-2#TRMPBF	
U2	OPTO_VOS617A-3X001T	VISHAY	VOS617A-3X001T	
C1	CAEMR-150U200V-16x26.5	NICHICON	UCS2D151MHD	
C2	CAEMR-470U280V-16x26.5	NICHICON	80ZLJ470M16X25	
C3	CAEMR-470U280V-16x26.5	NICHICON	80ZLJ470M16X25	
C4	CAEMR-470U280V-16x26.5	NICHICON	80ZLJ470M16X25	
C5	CX1Y1-4N7250V-DE1E3KX472MA4BN01F	MURATA	DE1E3KX472MA4BN01F	
C6	CX1Y1-4N7250V-DE1E3KX472MA4BN01F	MURATA	DE1E3KX472MA4BN01F	

continued on next page

Specifications (measured @ Ta= 25°C, full load after warm up unless otherwise stated)

Comp.	Description	Manufacturer	Manufacturer Part Number	Remarks
C7	CX1Y1-4N7250V-DE1E3KX472MA4BN01F	MURATA	DE1E3KX472MA4BN01F	
C10	CX1Y1-4N7250V-DE1E3KX472MA4BN01F	MURATA	DE1E3KX472MA4BN01F	
CON1	CONN-2P1R-691404910002B	WURTH	691404910002B	
CON2	CONN-2P1R-691404910002B	WURTH	691404910002B	
CON3	CONN-2P1R-691404910002B	WURTH	691404910002B	
CON4	CONN-2P1R-691404910002B	WURTH	691404910002B	
CON5	CONN-2P1R_64900229522	WURTH	64900229522	
CON6	CONN-2P1R_64900221122	WURTH	64900221122	
CON7	CONN-2P1R-691404910002B	WURTH	691404910002B	
D1	SDUR6030W	SMC DIODES SOLUTIONS	SDUR6030W	
D3	SDUR6030W	SMC DIODES SOLUTIONS	SDUR6030W	
FH1	FUSEHOLDER-0031.8231	SCHURTER	0031.8231	
HTSK1	HTSK_529702B02500G	AAVID THERMALLOY	529702B02500G	
M1	RP240H-11024SRW	RECOM	RP240H-11024SRW	not mounted
M2	RPA120H-11024SRW	RECOM	RPA120H-11024SRW	not mounted
M3	RP40-11024SFR	RECOM	RP40-11024SFR	not mounted
M4	RP90Q-11024SRW/N	RECOM	RP90Q-11024SRW/N	not mounted
P1	CONN-3P1R-22032031	MOLEX	22-03-2031	
Q1	IXTH80N20L	IXYS	IXTH80N20L	
FD4	FIDUCIAL_1MM			
FD5	FIDUCIAL_1MM			
FD6	FIDUCIAL_1MM			

### Typical Applications

High input voltage (with surge stopper)

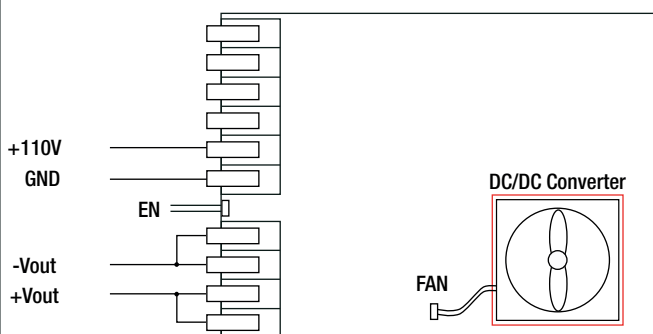

Low input voltage (surge stopper bridged)

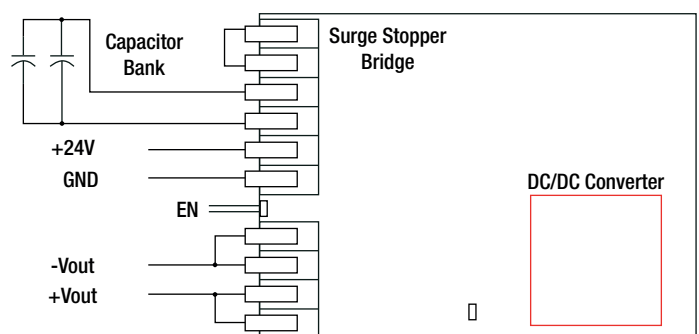

### PACKAGING INFORMATION

Parameter	Type	Value
Packaging Dimension (LxWxH)	carton	280.0 x 197.0 x 70.0mm
Packaging Quantity		1pcs

**Specifications** (measured @ Ta= 25°C, full load after warm up unless otherwise stated)

**Contents**

- R-REF04-RIA12 Reference Design
- Terms and Conditions

The product information and specifications may be subject to changes even without prior written notice. The product has been designed for various applications; its suitability lies in the responsibility of each customer. The products are not authorized for use in safety-critical applications without RECOM's explicit written consent. A safety-critical application is an application where a failure may reasonably be expected to endanger or cause loss of life, inflict bodily harm or damage property. The applicant shall indemnify and hold harmless RECOM, its affiliated companies and its representatives against any damage claims in connection with the unauthorized use of RECOM products in such safety-critical applications.

## X-ON Electronics

Largest Supplier of Electrical and Electronic Components

*Click to view similar products for [Power Management IC Development Tools](#) category:*

*Click to view products by [Recom Power](#) manufacturer:*

Other Similar products are found below :

[EVAL-ADM1168LQEBZ](#) [EVB-EP5348UI](#) [MIC23451-AAAYFL EV](#) [MIC5281YMME EV](#) [DA9063-EVAL](#) [ADP122-3.3-EVALZ](#) [ADP130-0.8-EVALZ](#) [ADP130-1.2-EVALZ](#) [ADP130-1.5-EVALZ](#) [ADP130-1.8-EVALZ](#) [ADP1714-3.3-EVALZ](#) [ADP1716-2.5-EVALZ](#) [ADP1740-1.5-EVALZ](#) [ADP1752-1.5-EVALZ](#) [ADP1828LC-EVALZ](#) [ADP1870-0.3-EVALZ](#) [ADP1871-0.6-EVALZ](#) [ADP1873-0.6-EVALZ](#) [ADP1874-0.3-EVALZ](#) [ADP1882-1.0-EVALZ](#) [ADP199CB-EVALZ](#) [ADP2102-1.25-EVALZ](#) [ADP2102-1.875EVALZ](#) [ADP2102-1.8-EVALZ](#) [ADP2102-2-EVALZ](#) [ADP2102-3-EVALZ](#) [ADP2102-4-EVALZ](#) [ADP2106-1.8-EVALZ](#) [ADP2147CB-110EVALZ](#) [AS3606-DB](#) [BQ24010EVM](#) [BQ24075TEVM](#) [BQ24155EVM](#) [BQ24157EVM-697](#) [BQ24160EVM-742](#) [BQ24296MEVM-655](#) [BQ25010EVM](#) [BQ3055EVM](#) [NCV891330PD50GEVB](#) [ISLUSBI2CKIT1Z](#) [LM2744EVAL](#) [LM2854EVAL](#) [LM3658SD-AEV/NOPB](#) [LM3658SDEV/NOPB](#) [LM3691TL-1.8EV/NOPB](#) [LM4510SDEV/NOPB](#) [LM5033SD-EVAL](#) [LP38512TS-1.8EV](#) [EVAL-ADM1186-1MBZ](#) [EVAL-ADM1186-2MBZ](#)