

SILICON RECTIFIER

VOLTAGE RANGE 50 to 1000 Volts CURRENT 1.0 Ampere

FEATURES

- * Low cost
- * Low leakage
- * Low forward voltage drop
- * High current capability

MECHANICAL DATA

- * Case: Molded plastic
- * Epoxy: Device has UL flammability classification 94V-0
- * Lead: MIL-STD-202E method 208C guaranteed
- * Mounting position: Any
- * Weight: 0.33 gram



DO-41

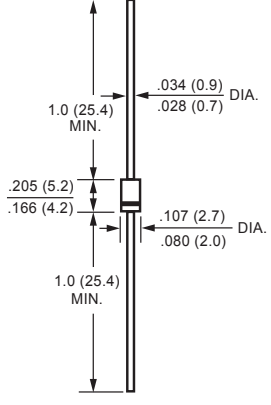

Dimensions in inches and (millimeters)

MAXIMUM RATINGS AND ELECTRICAL CHARACTERISTICS

Ratings at 25°C ambient temperature unless otherwise specified.
Single phase, half wave, 60 Hz, resistive or inductive load.
For capacitive load, derate current by 20%.

MAXIMUM RATINGS (At TA = 25°C unless otherwise noted)

RATINGS	SYMBOL	1N4001	1N4002	1N4003	1N4004	1N4005	1N4006	1N4007	UNITS
Maximum Recurrent Peak Reverse Voltage	VRRM	50	100	200	400	600	800	1000	Volts
Maximum RMS Voltage	VRMS	35	70	140	280	420	560	700	Volts
Maximum DC Blocking Voltage	VDC	50	100	200	400	600	800	1000	Volts
Maximum Average Forward Rectified Current at TA = 75°C	Io	1.0							Amps
Peak Forward Surge Current 8.3 ms single half sine-wave superimposed on rated load (JEDEC method)	IFSM	30							Amps
Typical Current Squared Time	i ² T	3.74							A ² S
Typical Junction Capacitance (Note)	Cj	15							pF
Typical Thermal Resistance	RθJA	50							°C/W
Operating and Storage Temperature Range	TJ, TSTG	-55 to + 150							°C

ELECTRICAL CHARACTERISTICS (At TA = 25°C unless otherwise noted)

CHARACTERISTICS	SYMBOL	1N4001	1N4002	1N4003	1N4004	1N4005	1N4006	1N4007	UNITS
Maximum Instantaneous Forward Voltage at 1.0A DC	VF	1.0							Volts
Maximum DC Reverse Current at Rated DC Blocking Voltage	@TA = 25°C	0.2							uAmps
	@TA = 100°C	25							
Maximum Full Load Reverse Current Average, Full Cycle .375" (9.5mm) lead length at TL = 75°C	IR	20							uAmps

NOTES : Measured at 1 MHz and applied reverse voltage of 4.0 volts

2017-04
REV:C

RATING AND CHARACTERISTIC CURVES (1N4001 THRU 1N4007)

FIG. 1 - TYPICAL FORWARD CURRENT DERATING CURVE

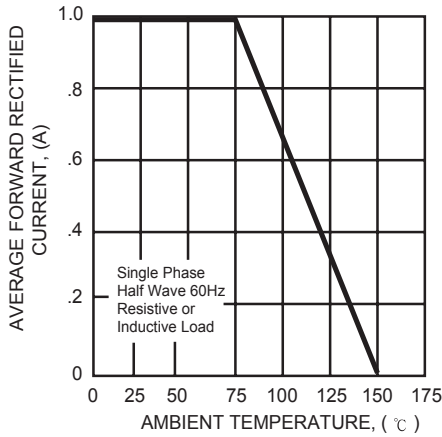

FIG. 2 - MAXIMUM INSTANTANEOUS FORWARD CHARACTERISTICS

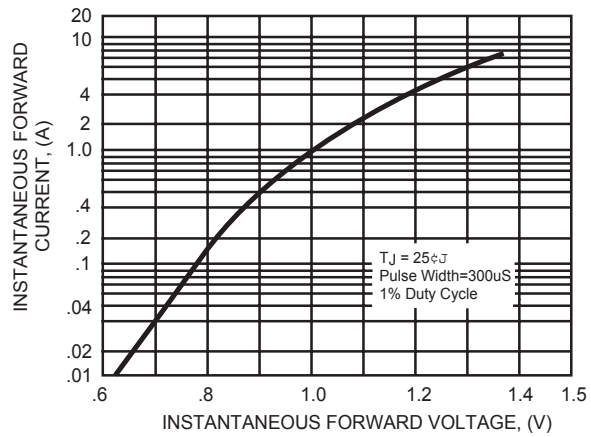

FIG. 3 - MAXIMUM NON-REPETITIVE FORWARD SURGE CURRENT

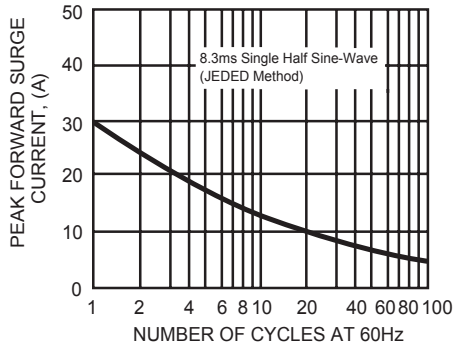

FIG. 4 - MAXIMUM REVERSE CHARACTERISTICS

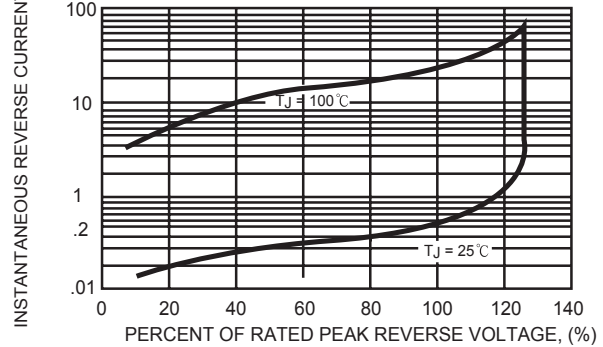
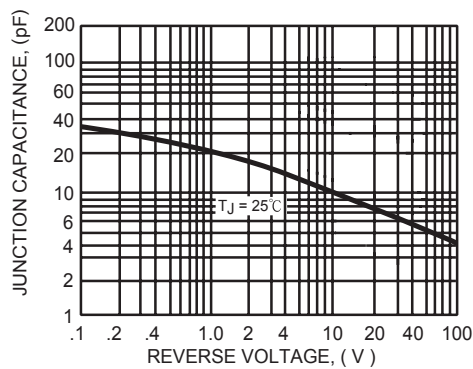

FIG. 5 - TYPICAL JUNCTION CAPACITANCE



AXIAL LEAD TAPING SPECIFICATIONS FOR RECTIFIERS

Axial lead devices are packed in accordance with EIA standard RS-296-D and specifications given below.

COMPONENT OUTLINE	COMPONENT PITCH A	INNER TAPE PITCH B		CUMULATIVE PITCH TOLERANCE
	$\pm 0.5\text{mm} (.020")$	$\pm 0.5\text{mm} (.020")$	$\pm 1.5\text{mm} (.059")$	
T-1	5.0mm	26.0mm		2.0mm/20pitch
R-1	5.0mm	26.0mm		2.0mm/20pitch
A-405	5.0mm	26.0mm		2.0mm/20pitch
A-405	5.0mm		52.4mm	2.0mm/20pitch
DO-41	5.0mm	26.0mm		2.0mm/20pitch
DO-41	5.0mm		52.4mm	2.0mm/10pitch
DO-15	5.0mm		52.4mm	2.0mm/10pitch
R-3	5.0mm		52.4mm	2.0mm/10pitch
DO-201AD	10.0mm		52.4mm	2.0mm/10pitch
R-6	10.0mm		52.4mm	2.0mm/10pitch

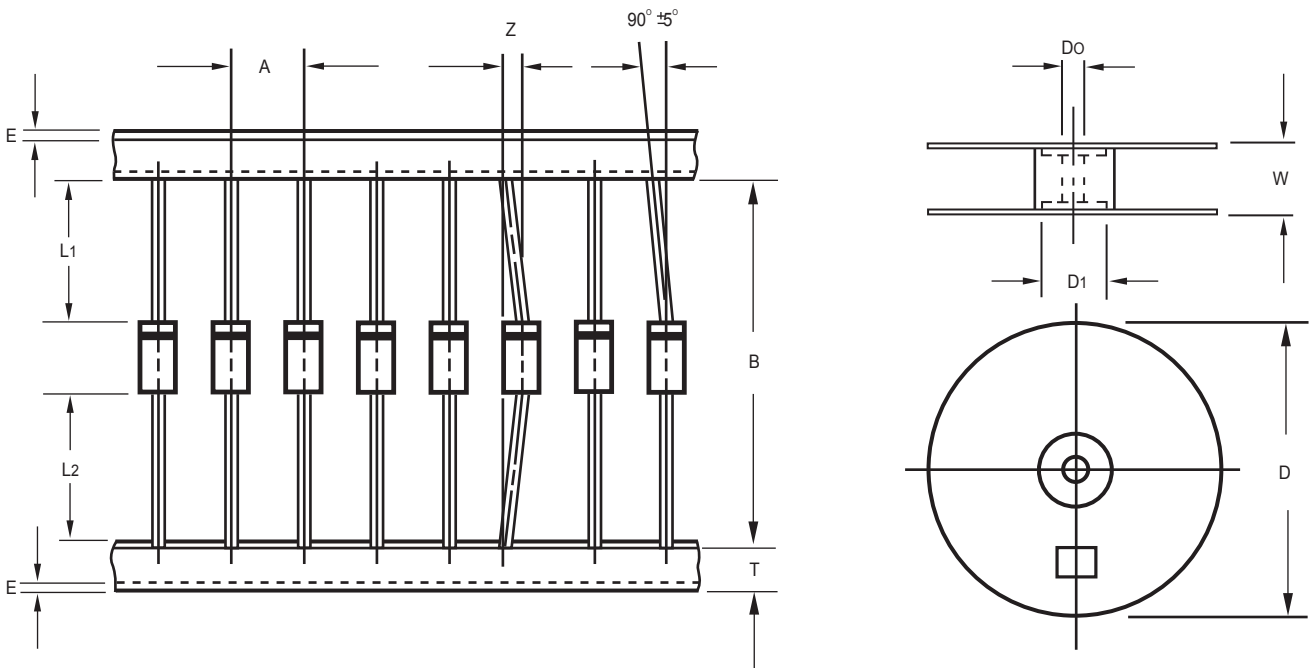

Fig.: Configuration of AXIAL LEAD TAPING

ITEM	SYMBOL	SPECIFICATIONS (mm)	SPECIFICATIONS (inch)
Component alignment	Z	1.2 Max.	0.047 Max.
Tape width	T	6.0 ± 0.4	0.236 ± 0.016
Exposed adhesive	E	0.8 Max.	0.032 Max.
Body eccentricity	$ L1-L2 $	1.0 Max.	0.039 Max.
Reel outside diameter	D	330.0	13.0
Reel inner diameter	D1	85.7 ± 0.3	3.374 ± 0.012
Feed hole diameter	Do	30.5 ± 0.4	1.201 ± 0.016
Reel width	W	79.0 ± 1.0	3.110 ± 0.039

Notes : 1. Each component lead shall be sandwiched between tapes for a minimum of 3.2mm (0.126").
2. The reel width "W" for 26mm taping is $50.0 \pm 1.0\text{mm} (1.97" \pm 0.040")$.

PACKAGING OF DIODE AND BRIDGE RECTIFIERS

BULK PACK

PACKAGE	PACKING CODE	EA PER BOX	INNER BOX SIZE (mm)	CARTON SIZE (mm)	EA PER CARTON	GROSS WEIGHT(Kg)
DO-41	-B	1,000	194*75*21	415*220*255	50,000	16.2

eg(TYPE):1N4007-B

REEL PACK

PACKAGE	PACKING CODE	EA PER REEL	EA PER INNER BOX	COMPONENT SPACE (mm)	TAPE SPACE (mm)	REEL DIA (mm)	CARTON SIZE (mm)	EA PER CARTON	GROSS WEIGHT(Kg)
DO-41	-T	5,000	5,000	5.0	52	330	355*350*335	20,000	10.49

eg(TYPE):1N4007-T

AMMO PACK

PACKAGE	PACKING CODE	REEL (EA)	COMPONENT SPACE(mm)	TAPE SPACE (mm)	BOX SIZE (mm)	CARTON SIZE(mm)	CARTON (EA)	GROSS WEIGHT (Kg)
DO-41	-F	3,000	5.0	52	255*73*100	400*268*225	30,000	13.0
DO-41	-E	3,000	5.0	26	256*48*94	365*270*217	42,000	12.41

eg(TYPE):1N4007-F,1N4007-E



Attachment information about 1N400X

1. Internal Circuit



2. Marking on the body

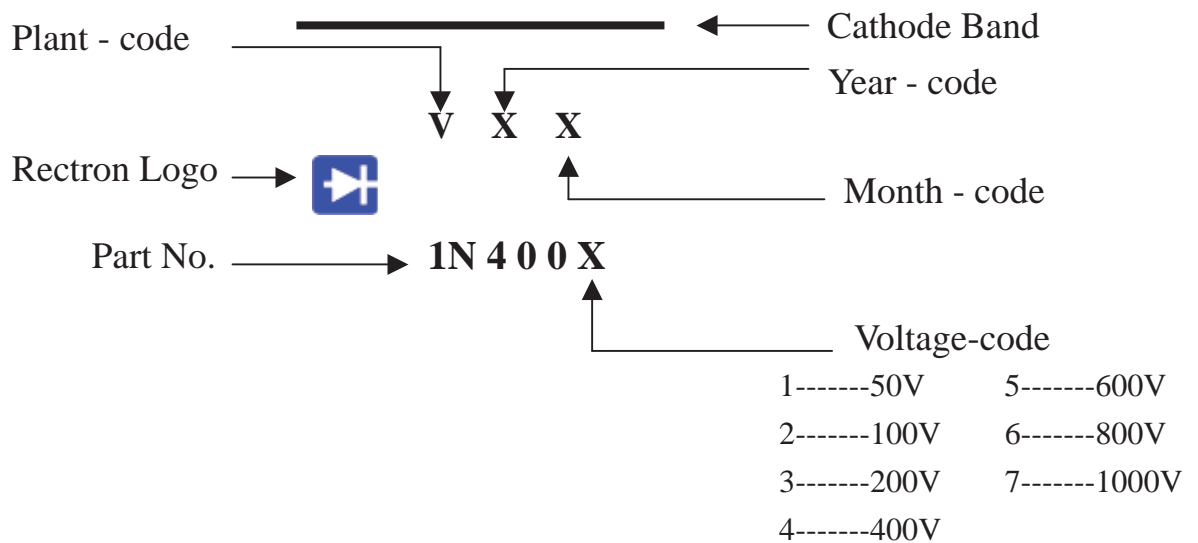

3. The net weight 330mg / pcs

4. Taping packaging specification

- 4.1 All polarized components must be oriented in one direction.
- 4.2 For diode, at least one side of the cathode lead tape should be red, and anode lead tape should be white.
- 4.3 A minimum 300 mm (12") leader shall be provided at each end of the reel.
- 4.4 Staples shall not be used for splicing. Splice length shall be 4.0 inches minimum and shall not be misaligned more than 0.8mm.



Attachment information about 1N400X

5. Items marked on the reel box and carton

5.1 On the reel (for -T)

**CUSTOMER
TYPE
QUANTITY
LOT NO.
Q.A.
REMARK**

5.2 On the box (for -E & -F)

**TYPE
QUANTITY
LOT NO.
Q.A.**

5.3 On the carton

**CUSTOMER
TYPE
QUANTITY
LOT NO.
REMARK**

1. BOX

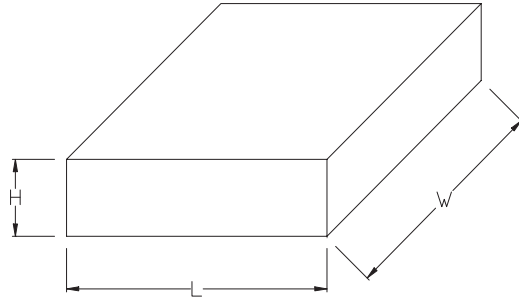

Packing Code	L (mm)	W (mm)	H (mm)
-F	255	100	73
-E	256	94	46

2. REEL

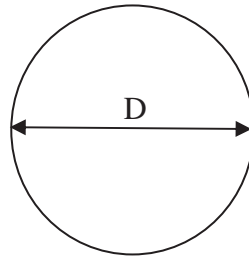

Packing Code	D (mm)
-T	178
-W	330

3. CARTON

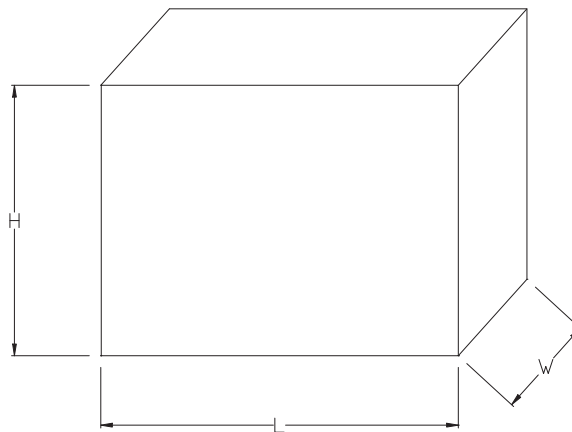

Packing Code	L (mm)	W (mm)	H (mm)
-T	355	350	335
-F	402	270	225
-E	347	320	220

DISCLAIMER NOTICE

Rectron Inc reserves the right to make changes without notice to any product specification herein to make corrections, modifications, enhancements or other changes. Rectron Inc or anyone on its behalf assumes no responsibility or liability for any errors or inaccuracies. Data sheet specifications and its information contained are intended to provide a product description only. "Typical" parameters which may be included on RECTRON data sheets and/ or specifications can and do vary in different applications and actual performance may vary over time. Rectron Inc does not assume any liability arising out of the application or use of any product or circuit.

Rectron products are not designed, intended or authorized for use in medical, life-saving implant or other applications intended for life-sustaining or other related applications where a failure or malfunction of component or circuitry may directly or indirectly cause injury or threaten a life without expressed written approval of Rectron Inc. Customers using or selling Rectron components for use in such applications do so at their own risk and shall agree to fully indemnify Rectron Inc and its subsidiaries harmless against all claims, damages and expenditures.

X-ON Electronics

Largest Supplier of Electrical and Electronic Components

Click to view similar products for [Rectifiers](#) category:

Click to view products by [Rectron](#) manufacturer:

Other Similar products are found below :

[70HFR40](#) [RL252-TP](#) [150KR30A](#) [1N5397](#) [NTE5841](#) [NTE6038](#) [SCF5000](#) [1N4002G](#) [1N4005-TR](#) [JANS1N6640US](#) [481235F](#)
[RRE02VS6SGTR](#) [067907F](#) [MS306](#) [70HF40](#) [T85HFL60S02](#) [US2JFL-TP](#) [A1N5404G-G](#) [CRS04\(T5L,TEMQ\)](#) [ACGRA4007-HF](#)
[ACGRB207-HF](#) [CLH03\(TE16L,Q\)](#) [ACGRC307-HF](#) [ACEFC304-HF](#) [NTE6356](#) [NTE6359](#) [NTE6002](#) [NTE6023](#) [NTE6039](#) [NTE6077](#)
[85HFR60](#) [40HFR60](#) [70HF120](#) [85HFR80](#) [D126A45C](#) [SCF7500](#) [D251N08B](#) [SCHJ22.5K](#) [SM100](#) [SCPA2](#) [SCH10000](#) [SDHD5K](#) [VS-](#)
[12FL100S10](#) [ACGRA4001-HF](#) [D1821SH45T PR](#) [D1251S45T](#) [NTE5990](#) [NTE6358](#) [NTE6162](#) [NTE5850](#)