

SOD-123 Plastic-Encapsulate Zener Diode

Features

- Low Zener Impedance
- Power Dissipation of 500mW
- High Stability and High Reliability

Mechanical Data

- SOD-123 Small Outline Plastic Package
- Polarity: Color band denotes cathode end
- Epoxy UL: 94V-0
- Mounting Position: Any
- P/N suffix V means Halogen-free
- P/N suffix V means AEC-Q101 qualified, e.g: BZT52C2V4V

MAXIMUM RATINGS AND ELECTRICAL CHARACTERISTICS

Ratings at 25 °C ambient temperature unless otherwise specified.
Single phase, resistive or inductive load.

SOD-123

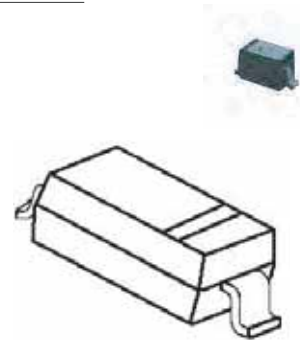

Maximum Ratings & Thermal Characteristics (Ratings at 25 °C ambient temperature unless otherwise specified.)

Parameters	Symbol	Value	Unit
Power Dissipation	Pd	500 ¹⁾	mW
Forward Voltage @IF=10mA	Vf	0.9 ²⁾	V
Storage temperature range	Ts,Tj	-65-+150	°C

- 1) Device mounted on ceramic PCB: 7.6mm x 9.4mm x 0.87mm with pad areas 25mm
- 2) Short duration test pulse used to minimize self-heating effect
- 3) f=1KHz

TYPE	MARKING 	Zener voltage Range $V_z(V)@I_{zt}$			Test current	Maximum Zener impedance			Maximum Reverse leakage current	
		Nom	Min	Max	$I_{zt}(mA)$	Z_{ZT}	Z_{ZK}	I_{ZK}	IR	VR
		(Volts)	(Volts)	(Volts)		(Ω)	(Ω)	(mA)	(μA)	(Volts)
BZT52C2V4	WX	2.4	2.28	2.52	5	100	600	1	50	1
BZT52C2V7	W1	2.7	2.57	2.84	5	100	600	1	20	1
BZT52C3V0	W2	3	2.85	3.15	5	95	600	1	10	1
BZT52C3V3	W3	3.3	3.14	3.47	5	95	600	1	5	1
BZT52C3V6	W4	3.6	3.42	3.78	5	90	600	1	5	1
BZT52C3V9	W5	3.9	3.71	4.1	5	90	600	1	3	1
BZT52C4V3	W6	4.3	4.09	4.52	5	90	600	1	3	1
BZT52C4V7	W7	4.7	4.47	4.94	5	80	500	1	3	2
BZT52C5V1	W8	5.1	4.85	5.36	5	60	480	1	2	2
BZT52C5V6	W9	5.6	5.32	5.88	5	40	400	1	1	2
BZT52C6V2	WA	6.2	5.89	6.51	5	10	150	1	3	4
BZT52C6V8	WB	6.8	6.46	7.14	5	15	80	1	2	4
BZT52C7V5	WC	7.5	7.13	7.88	5	15	80	1	1	5
BZT52C8V2	WD	8.2	7.79	8.61	5	15	80	1	0.7	5
BZT52C9V1	WE	9.1	8.65	9.56	5	15	100	1	0.5	6
BZT52C10	WF	10	9.5	10.5	5	20	150	1	0.2	7
BZT52C11	WG	11	10.45	11.55	5	20	150	1	0.1	8
BZT52C12	WH	12	11.4	12.6	5	25	150	1	0.1	8
BZT52C13	WI	13	12.35	13.65	5	30	170	1	0.1	8
BZT52C14	WY	14	13.3	14.7	5	25	110	1	0.1	10.5
BZT52C15	WJ	15	14.25	15.75	5	30	200	1	0.1	10.5
BZT52C16	WK	16	15.2	16.8	5	40	200	1	0.1	11.2
BZT52C18	WL	18	17.1	18.9	5	45	225	1	0.1	12.6
BZT52C20	WM	20	19	21	5	55	225	1	0.1	14
BZT52C22	WN	22	20.9	23.1	5	55	250	1	0.1	15.4
BZT52C24	WO	24	22.8	25.2	5	70	250	1	0.1	16.8
BZT52C27	WP	27	25.65	28.35	2	80	300	0.5	0.1	18.9
BZT52C30	WQ	30	28.5	31.5	2	80	300	0.5	0.1	21
BZT52C33	WR	33	31.35	34.65	2	80	325	0.5	0.1	23.1
BZT52C36	WS	36	34.2	37.8	2	90	350	0.5	0.1	25.2
BZT52C39	WT	39	37.05	40.95	2	130	350	0.5	0.1	27.3
BZT52C43	WU	43	40.85	45.15	2	150	375	0.5	0.1	30.1
BZT52C47	WV	47	44.65	59.35	2	170	1000	0.25	0.1	36
BZT52C51	X1	51	48.45	53.55	2	180	1300	0.25	0.1	39
BZT52C56	X2	56	53.2	58.8	2	200	1400	0.25	0.1	43
BZT52C62	X3	62	58.9	65.1	2	225	1400	0.25	0.1	47
BZT52C68	X4	68	64.6	71.4	2	240	1600	0.25	0.1	52
BZT52C75	X5	75	71.25	78.75	2	265	1700	0.25	0.1	56

RATING AND CHARACTERISTICS CURVES (BZT52C2V4V THRU BZT52C75V)

at $T_j = \text{constant}$ (pulsed)

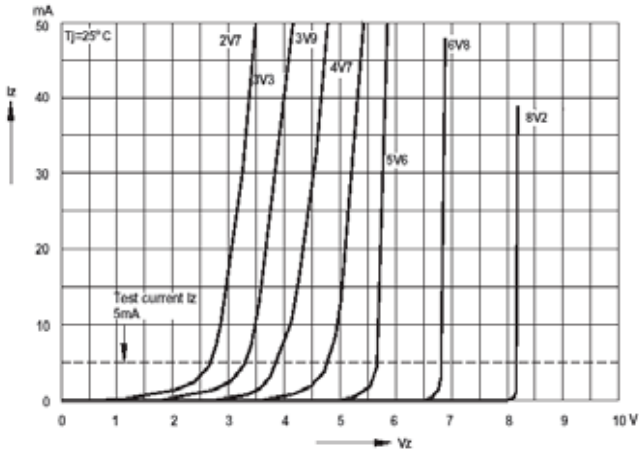

Forward characteristics

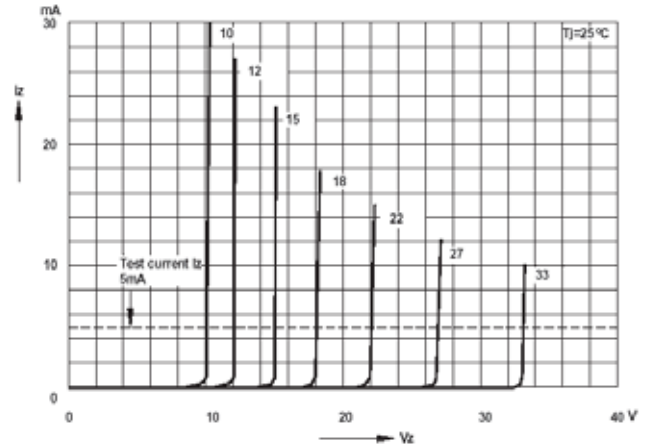

Admissible power dissipation versus ambient temperature

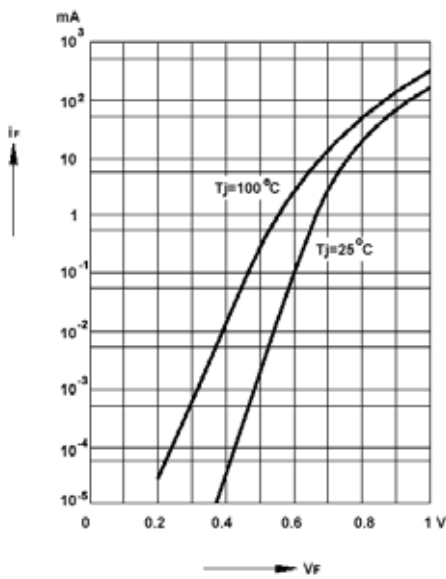

Dynamic resistance versus Zener voltage

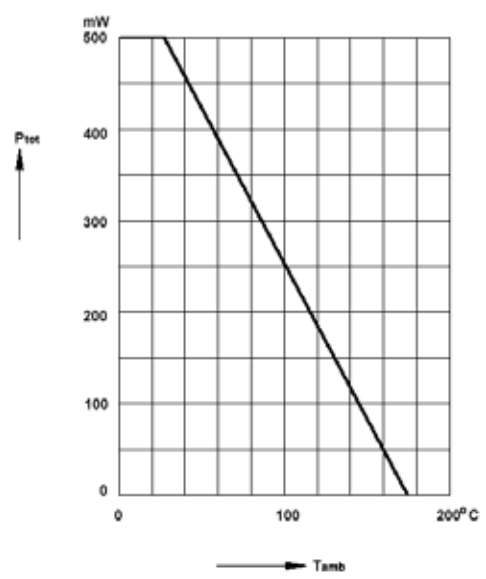
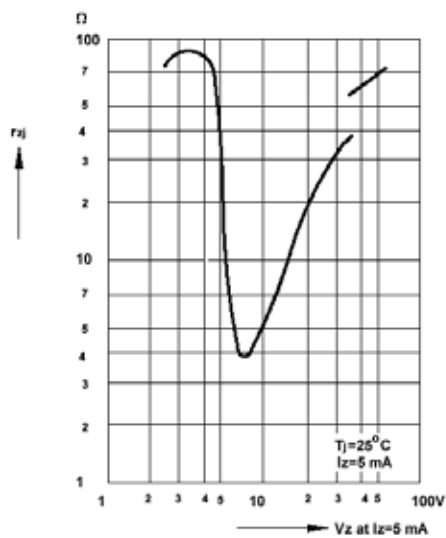

Temperature dependence of Zener voltage versus Zener voltage

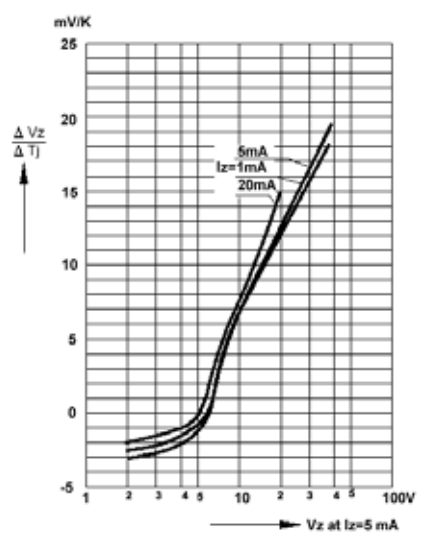

RATING AND CHARACTERISTICS CURVES (BZT52C2V4V THRU BZT52C75V)

Temperature dependence of Zener voltage versus Zener voltage

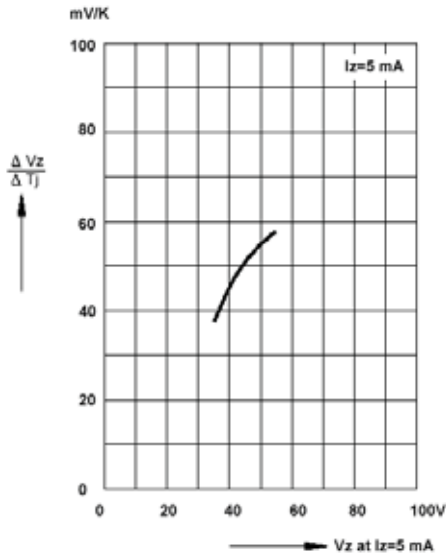

Change of Zener voltage versus junction temperature

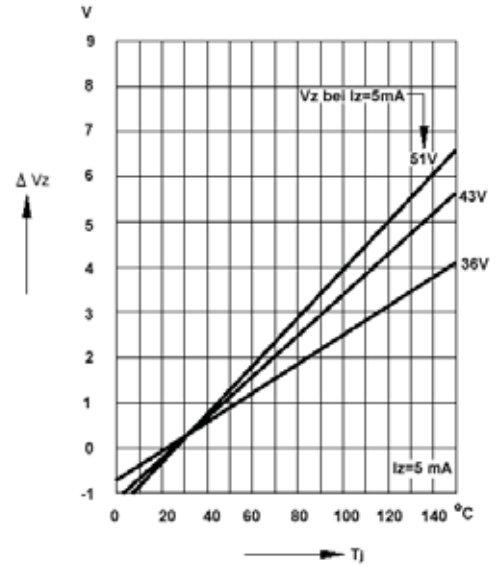

Change of Zener voltage versus junction temperature

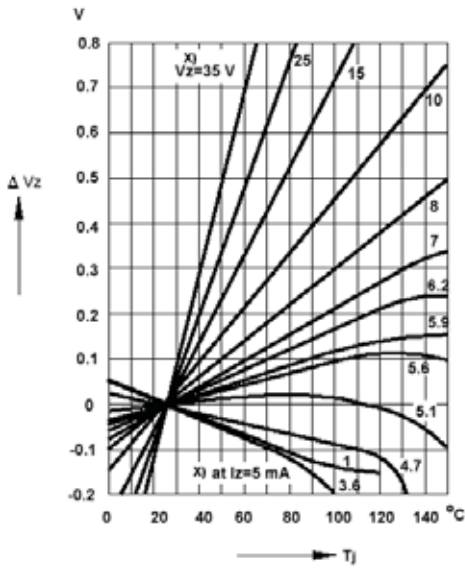

Change of Zener voltage from turn-on up to the point of thermal equilibrium versus Zener voltage

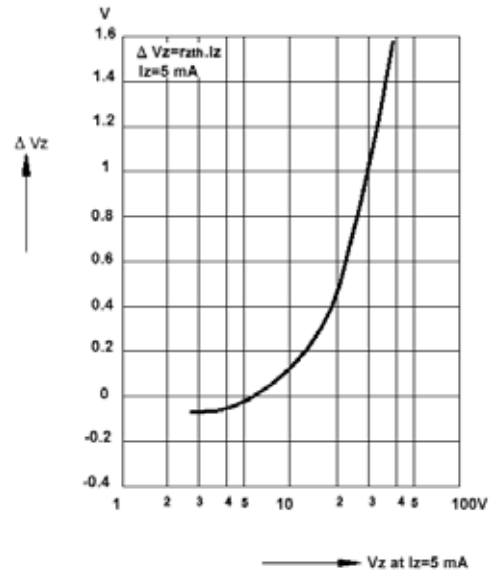

SOD-123 PACKAGE OUTLINE Plastic surface mounted package

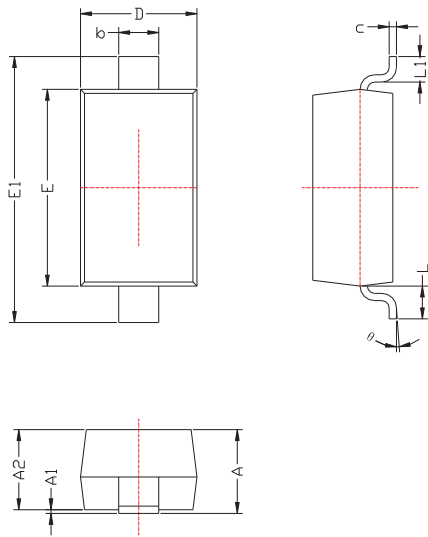

SYMBOL	DIMENSIONS	
	MIN.	MAX.
A	1.050	1.250
A1	0.000	0.100
A2	1.050	1.150
b	0.450	0.650
c	0.080	0.150
D	1.500	1.700
E	2.600	2.800
E1	3.550	3.850
L	0.500REF	
L1	0.250	0.450
θ	0°	8°

Precautions: PCB Design

Recommended land dimensions for SOD-123 diode. Electrode patterns for PCBs

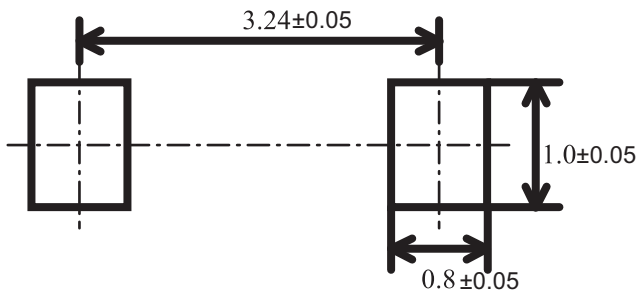

Unit: mm

SOD-123 Tape and Reel

SOD-123 Embossed Carrier Tape

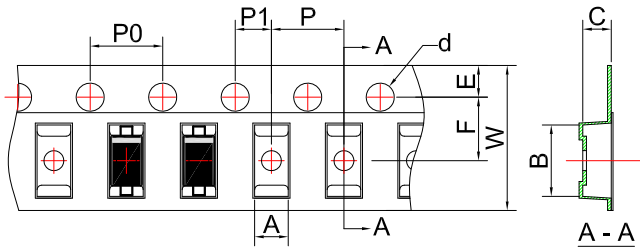

Packaging Description:

SOD-123 parts are shipped in tape. The carrier tape is made from a dissipative (carbon filled) polycarbonate resin. The cover tape is a multilayer film (heat Activated Adhesive in nature) primarily composed of polyester film, adhesive layer, sealant, and anti-static sprayed agent. The reels are blue in color and made of recyclable plastic.

Dimensions are in millimeter										
Pkg Type	A	B	C	d	E	F	P0	P	P1	W
SOD-123	1.85	3.94	1.57	Ø1.55	1.75	3.50	4.00	4.00	2.00	8.00
(Tolerance)	±0.05	±0.05	±0.05	±0.1	±0.1	±0.1	±0.1	±0.1	±0.1	+0.3/-0.1

SOD-123 Tape Leader and Trailer

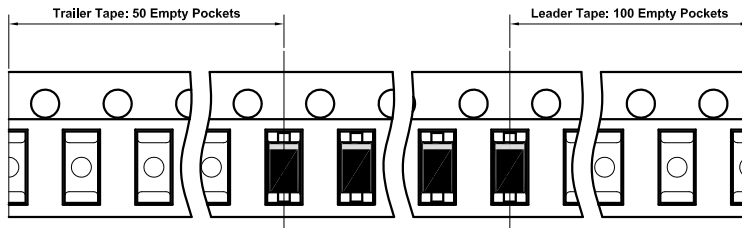

SOD-123 Reel

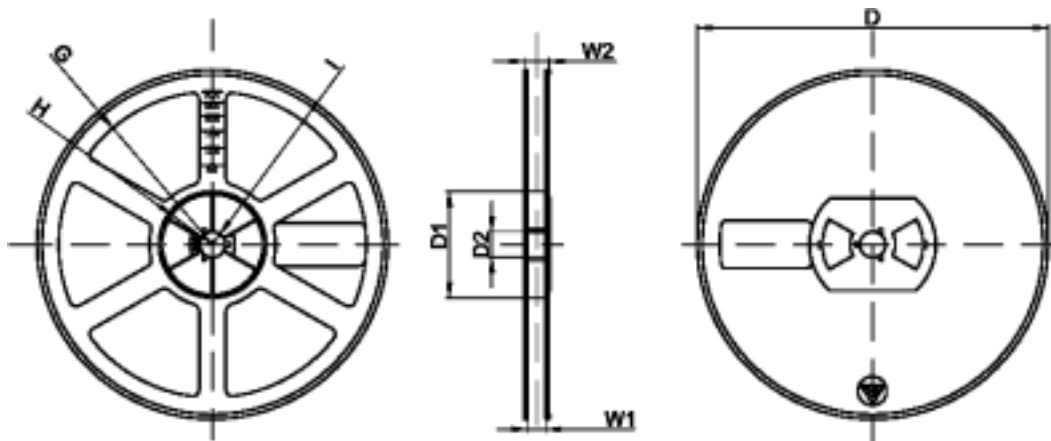

Unit: mm

Reel Option	D	D1	D2	G	H	I	W1	W2
7" Dia	Ø178.00	54.40	13.00	R78.00	R25.60	R6.50	9.50	12.30
Tolerance	±2	±1	±1	±1	±1	±1	±1	±1

Packaging Quantity

Reel	Reel Size	Box	Box Size (mm)	Carton	Carton Size (mm)
3,000	7 inch	45,000	210*208*203	180,000	440*440*230

X-ON Electronics

Largest Supplier of Electrical and Electronic Components

Click to view similar products for [Zener Diodes](#) category:

Click to view products by [Rectron](#) manufacturer:

Other Similar products are found below :

[RKZ13B2KG#P1](#) [RKZ5.6B2KJ#R1](#) [DL5234B](#) [EDZTE6113B](#) [1N4682](#) [1N4691](#) [1N4693](#) [1N4732A](#) [1N4736A](#) [1N4750A](#) [1N4759ARL](#)
[1N5241B](#) [1N5365B](#) [1N5369B](#) [1N747A](#) [1N959B](#) [1N964B](#) [1N966B](#) [1N968B](#) [1N972B](#) [NTE5121A](#) [NTE5147A](#) [NTE5152A](#) [NTE5155A](#)
[NTE5164A](#) [JANS1N4974US](#) [1N4692](#) [1N4700](#) [1N4702](#) [1N4704](#) [1N4711](#) [1N4714](#) [1N4737A](#) [1N4745ARL](#) [1N4752A](#) [1N4752ARL](#)
[1N4760ARL](#) [1N5221B](#) [1N5231B-TR](#) [1N5236B](#) [1N5241BTR](#) [1N5242BTR](#) [1N5350B](#) [1N5352B](#) [1N961BRR1](#) [1N964BRL](#) [RKZ5.1BKU#P6](#)
[3SMAJ5946B-TP](#) [3SMAJ5950B-TP](#) [3SMBJ5925B-TP](#)