

Description

The ICS557-08 is a 2:1 multiplexer chip that allows the user to select one of the two HCSL (Host Clock Signal Level) input pairs and fans out to one pair of differential HCSL or LVDS outputs. This chip is suited especially for PCI-Express applications, where there is a need to select the PCI-Express clock either locally from the PCI-E card or from the motherboard.

Features

- Packaged in 16-pin TSSOP
- Pb (lead) free package
- Operating voltage of 3.3 V
- Low power consumption
- Input clock frequency of up to 200 MHz
- **For PCIe Gen2/3 applications, see the 5V41068A**

Block Diagram

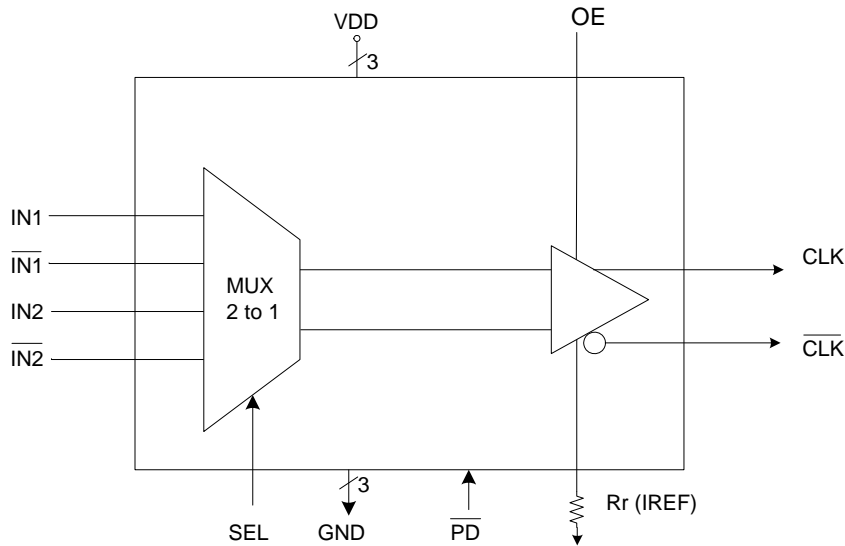

Pin Assignment

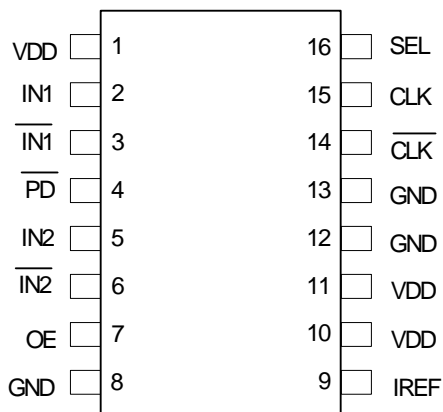

16-pin (173 mil) TSSOP

Select Table

SEL	Input Pair Selected
0	IN2/ $\overline{\text{IN2}}$
1	IN1/ $\overline{\text{IN1}}$

Pin Descriptions

Pin	Pin Name	Pin Type	Pin Description
1	VDD	Power	Connect to +3.3 V. Supply voltage for Input clocks.
2	IN1	Input	HCSL true input signal 1.
3	IN1	Input	HCSL complimentary input signal 1.
4	PD	Input	Powers down the chip and tri-states outputs when low. Internal pull-up
5	IN2	Input	HCSL true input signal 2.
6	IN2	Input	HCSL complimentary input signal 2.
7	OE	Input	Provides output or, tri-states output (High = enable outputs; Low = disable). Internal pull-up resistor.
8	GND	Power	Connect to ground.
9	IREF	Output	Precision resistor attached to this pin is connected to the internal current
10	VDD	Power	Connect to +3.3 V. Supply Voltage for Output Clocks.
11	VDD	Power	Connect to +3.3 V. Supply Voltage for Output Clocks.
12	GND	Power	Connect to ground.
13	GND	Power	Connect to ground.
14	CLK	Output	HCSL/LVDS Complimentary output clock .
15	CLK	Output	HCSL/LVDS True output clock.
16	SEL	Input	SEL=1 selects IN1/ $\overline{\text{IN1}}$. SEL =0 selects IN2/ $\overline{\text{IN2}}$. Internal pull-up resistor.

Application Information

Decoupling Capacitors

As with any high-performance mixed-signal IC, the ICS557-08 must be isolated from system power supply noise to perform optimally.

Decoupling capacitors of 0.01 μ F must be connected between each VDD and the PCB ground plane.

PCB Layout Recommendations

For optimum device performance and lowest output phase noise, the following guidelines should be observed.

Each 0.01 μ F decoupling capacitor should be mounted on the component side of the board as close to the VDD pin as possible. No vias should be used between decoupling capacitor and VDD pin. The PCB trace to VDD pin should be kept as short as possible, as should the PCB trace to the ground via. Distance of the ferrite bead and bulk decoupling from the device is less critical.

2) An optimum layout is one with all components on the same side of the board, minimizing vias through other signal layers (the ferrite bead and bulk decoupling capacitor can be mounted on the back). Other signal traces should be routed away from the ICS557-08.

This includes signal traces just underneath the device, or on layers adjacent to the ground plane layer used by the device.

External Components

A minimum number of external components are required for proper operation. Decoupling capacitors of 0.01 μ F should be connected between VDD and GND pins as close to the device as possible.

Current Reference Source R_r (I_{ref})

If board target trace impedance (Z) is 50 Ω , then $R_r = 475\Omega$ (1%), providing IREF of 2.32 mA, output current (I_{OH}) is equal to 6*IREF.

Load Resistors R_L

Since the clock outputs are open source outputs, 50 Ω external resistors to ground are to be connected at each clock output.

Output Termination

The PCI-Express differential clock outputs of the ICS557-08 are open source drivers and require an external series resistor and a resistor to ground. These resistor values and their allowable locations are shown in detail in the **PCI-Express Layout Guidelines** section.

The ICS557-08 can also be configured for LVDS compatible voltage levels. See the **LVDS Compatible Layout Guidelines** section.

Output Structures

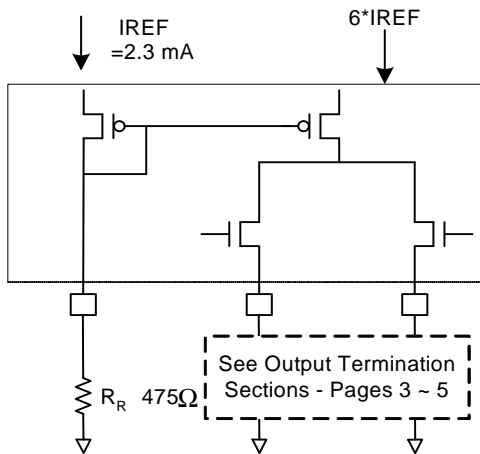

General PCB Layout Recommendations

For optimum device performance and lowest output phase noise, the following guidelines should be observed.

1. Each 0.01 μ F decoupling capacitor should be mounted on the component side of the board as close to the VDD pin as possible.
2. No vias should be used between decoupling capacitor and VDD pin.
3. The PCB trace to VDD pin should be kept as short as possible, as should the PCB trace to the ground via. Distance of the ferrite bead and bulk decoupling from the device is less critical.
4. An optimum layout is one with all components on the same side of the board, minimizing vias through other signal layers (any ferrite beads and bulk decoupling capacitors can be mounted on the back). Other signal traces should be routed away from the ICS557-08. This includes signal traces just underneath the device, or on layers adjacent to the ground plane layer used by the device.

PCI-Express Layout Guidelines

Common Recommendations for Differential Routing	Dimension or Value	Unit
L1 length, Route as non-coupled 50 ohm trace.	0.5 max	inch
L2 length, Route as non-coupled 50 ohm trace.	0.2 max	inch
L3 length, Route as non-coupled 50 ohm trace.	0.2 max	inch
R_S	33	ohm
R_T	49.9	ohm

Differential Routing on a Single PCB	Dimension or Value	Unit
L4 length, Route as coupled microstrip 100 ohm differential trace.	2 min to 16 max	inch
L4 length, Route as coupled stripline 100 ohm differential trace.	1.8 min to 14.4 max	inch

Differential Routing to a PCI Express Connector	Dimension or Value	Unit
L4 length, Route as coupled microstrip 100 ohm differential trace.	0.25 to 14 max	inch
L4 length, Route as coupled stripline 100 ohm differential trace.	0.225 min to 12.6 max	inch

PCI-Express Device Routing

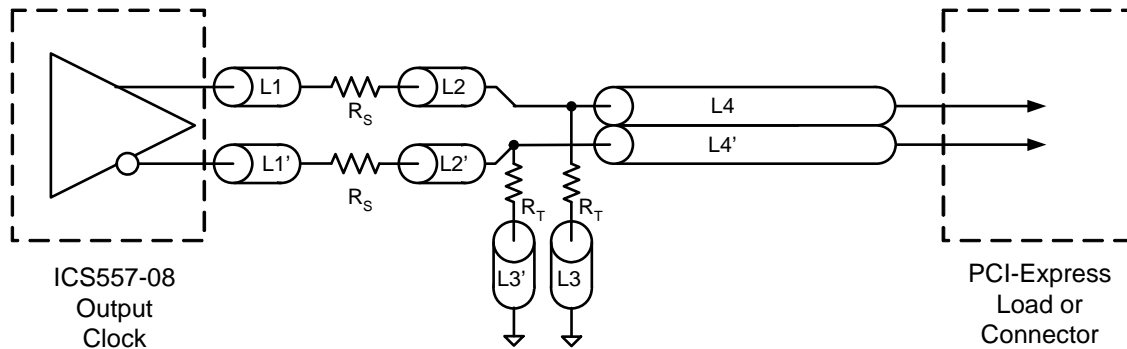

Typical PCI-Express (HCSL) Waveform

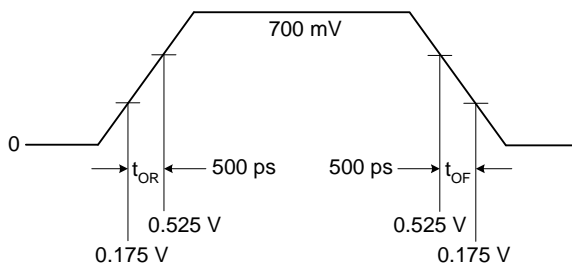

LVDS Compatible Layout Guidelines

Alternative Termination for LVDS and other Common Differential Signals							
V _{diff}	V _{p-p}	V _{cm}	R1	R2	R3	R4	Note
0.45v	0.22v	1.08	33	150	100	100	
0.58	0.28	0.6	33	78.7	137	100	
0.80	0.40	0.6	33	78.7	none	100	ICS874003i-02 input compatible
0.60	0.3	1.2	33	174	140	100	Standard LVDS

R1a = R1b = R1

R2a = R2b = R2

LVDS Device Routing

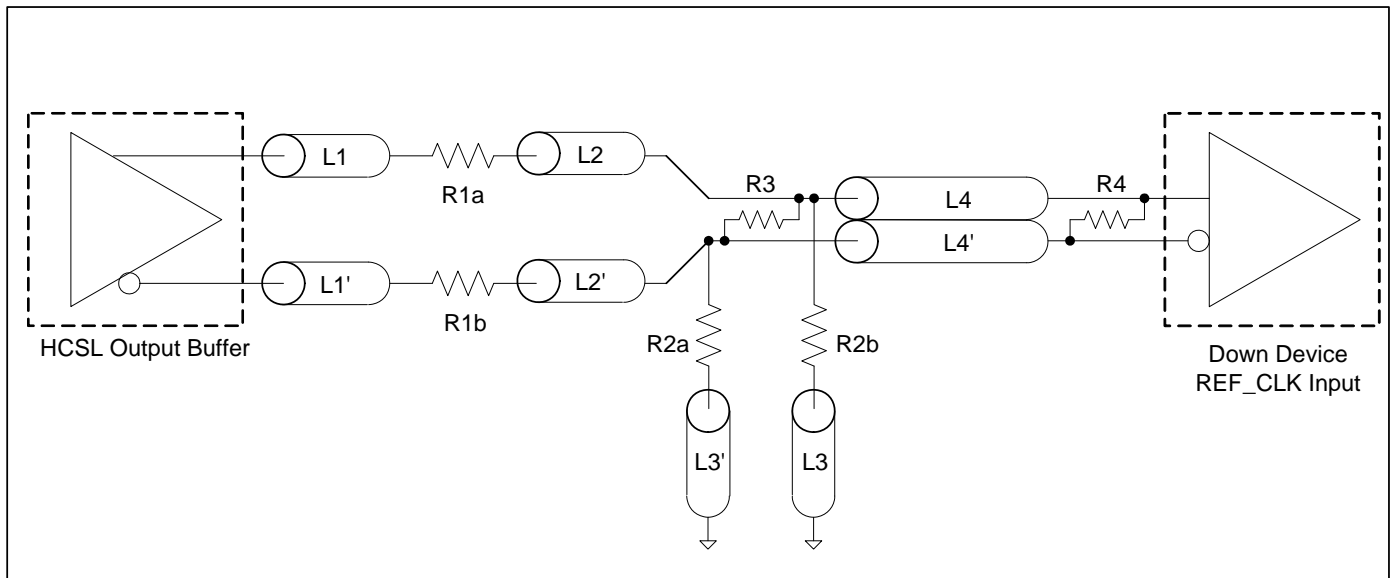

Typical LVDS Waveform

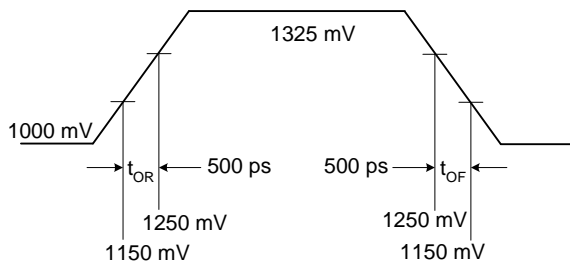

Absolute Maximum Ratings

Stresses above the ratings listed below can cause permanent damage to the ICS557-08. These ratings are stress ratings only. Functional operation of the device at these or any other conditions above those indicated in the operational sections of the specifications is not implied. Exposure to absolute maximum rating conditions for extended periods can affect product reliability. Electrical parameters are guaranteed only over the recommended operating temperature range.

Item	Rating
Supply Voltage, VDD	7 V
All Inputs and Outputs	-0.5 V to VDD+0.5 V
Ambient Operating Temperature	-40 to +85° C
Storage Temperature	-65 to +150° C
Junction Temperature	125° C
Soldering Temperature	260° C
ESD Protection (Input)	2000 V min. (HBM)

DC Electrical Characteristics

Unless stated otherwise, VDD = 3.3 V ±5%, Ambient Temperature -40 to +85° C

Parameter	Symbol	Conditions	Min.	Typ.	Max.	Units
Supply Voltage	V		3.135		3.465	V
Input High Voltage ¹	V _{IH}	OE, SEL, $\overline{\text{PD}}$	2.0		VDD +0.3	V
Input Low Voltage ¹	V _{IL}	OE, SEL, $\overline{\text{PD}}$	VSS-0.3		0.8	V
Input Leakage Current ²	I _{IL}	0 < V _{in} < VDD	-5		5	μA
Operating Supply Current	I _{DD}	50Ω, 2 pF			40	mA
	I _{DDOE}	OE =Low			20	mA
	I _{DDPD}	No load, $\overline{\text{PD}}$ =Low			400	μA
Input Capacitance	C _{IN}	Input pin capacitance			7	pF
Output Capacitance	C _{OUT}	Output pin capacitance			6	pF
Pin Inductance	L _{PIN}				5	nH
Output Resistance	R _{OUT}	CLK outputs	3.0			kΩ
Pull-up Resistor	R _{PUP}	OE, SEL, $\overline{\text{PD}}$		110		kΩ

1. Single edge is monotonic when transitioning through region.
2. Inputs with pull-ups/-downs are not included.

AC Electrical Characteristics

Unless stated otherwise, VDD=3.3 V ±5%, Ambient Temperature -40 to +85° C

Parameter	Symbol	Conditions	Min.	Typ.	Max.	Units
Operating Frequency		HCSL termination			200	MHz
		LVDS termination			100	MHz
Input High Voltage ^{1,2}	V _{IH}	HCSL	660	700	850	mV
Input Low Voltage ^{1,2}	V _{IL}	HCSL	-150	0		mV
Differential Input Voltages	V _{ID}	LVDS	250	350	450	mV
Input Offset Voltage	(V _{IS})	LVDS	1.125	1.25	1.375	V
Output High Voltage ^{1,2}	V _{OH}	HCSL	660	700	850	mV
Output Low Voltage ^{1,2}	V _{OL}	HCSL	-150	0	27	mV
Crossing Point Voltage ^{1,2}		Absolute	250	350	550	mV
Crossing Point Voltage ^{1,2,4}		Variation over all edges			140	mV
Rise Time ^{1,2}	t _{OR}	From 0.175 V to 0.525 V	175	332	700	ps
Fall Time ^{1,2}	t _{OF}	From 0.525 V to 0.175 V	175	344	700	ps
Rise/Fall Time Variation ^{1,2}					125	ps
Duty Cycle ^{1,3}			45		55	%
Output Enable Time ⁵		All outputs		10		μs
Output Disable Time ⁵		All outputs		10		μs
Stabilization Time	t _{STABLE}	From power-up VDD=3.3 V		3.0		ms
Input to Output Delay		Input differential clock to output differential clock delay measured at crossing point of input levels to crossing point of output levels	2	4	6	ns

¹ Test setup is R_L=50 ohms with 2 pF, R_r = 475Ω (1%).

² Measurement taken from a single-ended waveform.

³ Measurement taken from a differential waveform.

⁴ Measured at the crossing point where instantaneous voltages of both CLK and $\overline{\text{CLK}}$ are equal.

⁵ CLK and $\overline{\text{CLK}}$ pins are tri-stated when OE is Low asserted. CLK and $\overline{\text{CLK}}$ are driven differential when OE is High unless its $\overline{\text{PD}}$ = low.

Thermal Characteristics

Parameter	Symbol	Conditions	Min.	Typ.	Max.	Units
Thermal Resistance Junction to Ambient	θ_{JA}	Still air		93		°C/W
	θ_{JA}	1 m/s air flow		78		°C/W
	θ_{JA}	3 m/s air flow		65		°C/W
Thermal Resistance Junction to Case	θ_{JC}			20		°C/W

Marking Diagram (ICS557G-08LF)

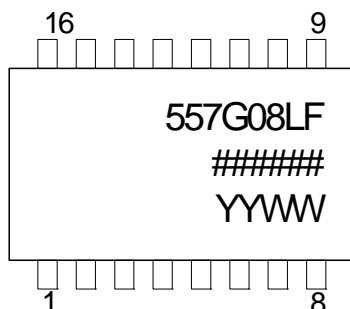

Marking Diagram (ICS557GI-08LF)

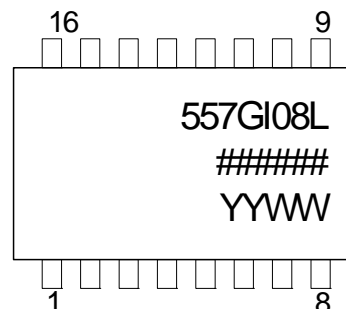

Notes:

1. ##### is the lot code.
2. YYWW is the last two digits of the year, and the week number that the part was assembled.
3. "LF" denotes Pb free package.
4. "I" denotes industrial temperature device
5. Bottom marking: (origin). Origin = country of origin if not USA.

Package Outline and Package Dimensions (16-pin TSSOP, 173 Mil. Narrow Body)

Package dimensions are kept current with JEDEC Publication No. 95

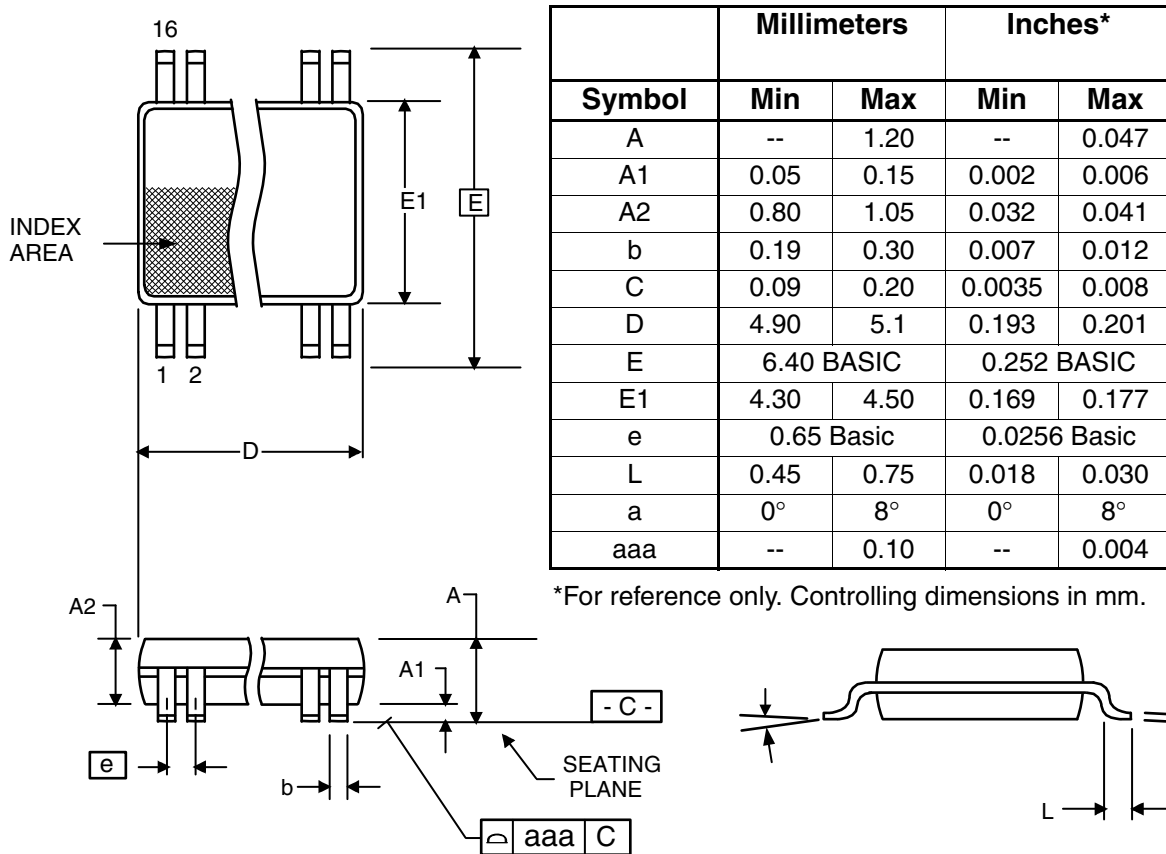

Ordering Information

Part / Order Number	Marking	Shipping Packaging	Package	Temperature
557G-08LF	see page 9	Tubes	16-pin TSSOP	0 to +70° C
557G-08LFT		Tape and Reel	16-pin TSSOP	0 to +70° C
557GI-08LF		Tubes	16-pin TSSOP	-40 to +85° C
557GI-08LFT		Tape and Reel	16-pin TSSOP	-40 to +85° C

"LF" suffix to the part number are the Pb-Free configuration and are RoHS compliant.

While the information presented herein has been checked for both accuracy and reliability, Integrated Device Technology (IDT) assumes no responsibility for either its use or for the infringement of any patents or other rights of third parties, which would result from its use. No other circuits, patents, or licenses are implied. This product is intended for use in normal commercial applications. Any other applications such as those requiring extended temperature range, high reliability, or other extraordinary environmental requirements are not recommended without additional processing by IDT. IDT reserves the right to change any circuitry or specifications without notice. IDT does not authorize or warrant any IDT product for use in life support devices or critical medical instruments.

Revision History

Rev.	Originator	Date	Description of Change
C	D.Chan	02/16/06	Added industrial temp range; updated PCI-Express Waveform diagram to include 0.525 V; changed "Supply Voltage, VDD" spec in Absolute Max. Ratings from 5.5 V to 7 V; changed CLKOUT to CLK and $\overline{\text{CLK}}$; added marking diagrams for I-temp device.
D	Arvind	05/17/07	Removed Cycle-to-cycle jitter spec.
E		06/26/07	Added 27mV to VOL max. spec
F		09/24/09	Added EOL note for non-green parts.
G		10/05/09	Updated "Input to Output Delay" parameter.
H		05/13/10	Removed EOL note for non-green parts.
J	A.T.	12/15/10	Updated LVDS termination table and diagram
K	LPL	08/02/11	Updates to product description and Features bullets on pg.1
L	K.B.	11/21/11	1. Added "Gen1" to title 2. Added note in Features section, "For PCIe Gen2/3 applications, see the 5V41068A"

IMPORTANT NOTICE AND DISCLAIMER

RENESAS ELECTRONICS CORPORATION AND ITS SUBSIDIARIES (“RENESAS”) PROVIDES TECHNICAL SPECIFICATIONS AND RELIABILITY DATA (INCLUDING DATASHEETS), DESIGN RESOURCES (INCLUDING REFERENCE DESIGNS), APPLICATION OR OTHER DESIGN ADVICE, WEB TOOLS, SAFETY INFORMATION, AND OTHER RESOURCES “AS IS” AND WITH ALL FAULTS, AND DISCLAIMS ALL WARRANTIES, EXPRESS OR IMPLIED, INCLUDING, WITHOUT LIMITATION, ANY IMPLIED WARRANTIES OF MERCHANTABILITY, FITNESS FOR A PARTICULAR PURPOSE, OR NON-INFRINGEMENT OF THIRD PARTY INTELLECTUAL PROPERTY RIGHTS.

These resources are intended for developers skilled in the art designing with Renesas products. You are solely responsible for (1) selecting the appropriate products for your application, (2) designing, validating, and testing your application, and (3) ensuring your application meets applicable standards, and any other safety, security, or other requirements. These resources are subject to change without notice. Renesas grants you permission to use these resources only for development of an application that uses Renesas products. Other reproduction or use of these resources is strictly prohibited. No license is granted to any other Renesas intellectual property or to any third party intellectual property. Renesas disclaims responsibility for, and you will fully indemnify Renesas and its representatives against, any claims, damages, costs, losses, or liabilities arising out of your use of these resources. Renesas' products are provided only subject to Renesas' Terms and Conditions of Sale or other applicable terms agreed to in writing. No use of any Renesas resources expands or otherwise alters any applicable warranties or warranty disclaimers for these products.

(Rev.1.0 Mar 2020)

Corporate Headquarters

TOYOSU FORESIA, 3-2-24 Toyosu,
Koto-ku, Tokyo 135-0061, Japan
www.renesas.com

Contact Information

For further information on a product, technology, the most up-to-date version of a document, or your nearest sales office, please visit:
www.renesas.com/contact/

Trademarks

Renesas and the Renesas logo are trademarks of Renesas Electronics Corporation. All trademarks and registered trademarks are the property of their respective owners.

X-ON Electronics

Largest Supplier of Electrical and Electronic Components

Click to view similar products for [Encoders, Decoders, Multiplexers & Demultiplexers](#) *category:*

Click to view products by [Renesas](#) *manufacturer:*

Other Similar products are found below :

[MC74HC163ADTG](#) [74HC253N](#) [NLV74VHC1G01DFT1G](#) [TC74AC138P\(F\)](#) [NLV14051BDR2G](#) [NLV74HC238ADTR2G](#) [COMX-CAR-210](#)
[NTE74LS247](#) [SN74LS148N](#) [8CA3052APGGI8](#) [TC74VHC138F\(EL,K,F](#) [PI3B3251LE](#) [PI3B3251QE](#) [NTE4028B](#) [NTE4514B](#) [NTE4515B](#)
[NTE4543B](#) [NTE4547B](#) [NTE74LS249](#) [MC74LVX257DG](#) [M74HCT4851ADWR2G](#) [AP4373AW5-7-01](#) [74HCT4051D,118](#) [74HC151D,653](#)
[MC74LVX257DTR2G](#) [74VHC4066AFT\(BJ\)](#) [74VHCT138AFT\(BJ\)](#) [74HC158D.652](#) [74HC4052D\(BJ\)](#) [74VHC138MTC](#) [COMX-CAR-P1](#)
[74VHC138MTCX](#) [74HC138D\(BJ\)](#) [NL7SZ19DFT2G](#) [74AHCT138T16-13](#) [74LCX157FT\(AJ\)](#) [NL7SZ18MUR2G](#) [SN74CBTLV3257PWG4](#)
[SN74ALS156DR](#) [SN74AHCT139PWR](#) [74HC257D.652](#) [74HCT153D.652](#) [74HC253D.652](#) [74HC139D.652](#) [74HCT139D.652](#)
[HEF4543BT.652](#) [TC74HC4052AFT\(EL\)](#) [74HC139PW-Q100J](#) [SN74LVC257AMPWREP](#) [74HC138DB.112](#)