

Description

The ICS558-01 accepts a high speed input of either PECL or CMOS, integrates a divider of 1, 2, 3, or 4, and provides four CMOS low skew outputs. The chip also has output enables so that one, three, or all four outputs can be tri-stated.

The ICS558-01 is a member of the IDT Clock Blocks™ family of clock generation, synchronization, and distribution devices.

Features

- 16-pin TSSOP package
- Pb (lead) free package
- Selectable PECL or CMOS inputs
- Operates up to 250 MHz
- Works as a voltage translator
- Four low skew (<250 ps) outputs
- Selectable internal divider
- Operating input voltages of 3.3 V or 5.0 V
- Operating output voltages of 2.5 V, 3.3 V or 5.0 V
- Ideal for IA64 designs

Block Diagram

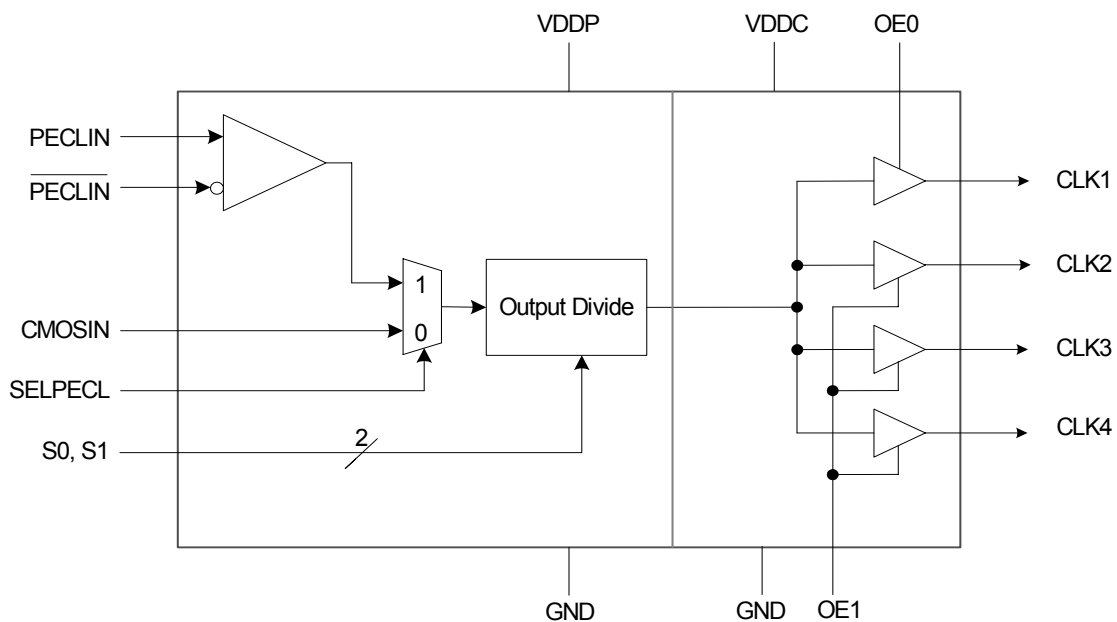

Pin Assignment

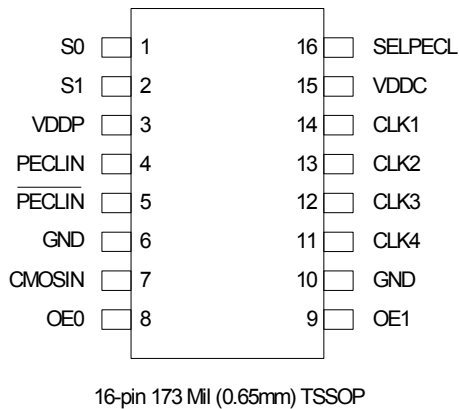

Input Clock Selection

| SELPECL | Input |
|---------|--------|
| 0 | CMOSIN |
| 1 | PECLIN |

Tri-State Table

| OE1 | OE0 | CLK 1 | CLK 2, 3, 4 |
|-----|-----|-----------|-------------|
| 0 | 0 | Tri-state | Tri-state |
| 0 | 1 | Clock ON | Tri-state |
| 1 | 0 | Tri-state | Clock ON |
| 1 | 1 | Clock ON | Clock ON |

Output Divide Selection

| S1 | S0 | Output Divide |
|----|----|---------------|
| 0 | 0 | /1 |
| 0 | 1 | /2 |
| 1 | 0 | /3 |
| 1 | 1 | /4 |

Pin Descriptions

| Pin Number | Pin Name | Pin Type | Pin Description |
|------------|----------|-------------|---|
| 1 | S0 | Input | Select 0 for output divider. See table above. Internal pull-up to VDDP. |
| 2 | S1 | Input | Select 1 for output divider. See table above. Internal pull-up to VDDP. |
| 3 | VDDP | Power | Connect to +3.3 V or +5 V. Decouple to pin 6. |
| 4 | PECLIN | Clock Input | PECL input. Connect to ground if not used. |
| 5 | PECLIN | Clock Input | Complimentary PECL input. Connect to ground if not used. |
| 6 | GND | Power | Connect to ground. |
| 7 | CMOSIN | Clock Input | CMOS input. Connect to ground if not used. |
| 8 | OE0 | Input | Output Enable 0. See table above. Internal pull-up to VDDP. |
| 9 | OE1 | Input | Output Enable 1. See table above. Internal pull-up to VDDP. |
| 10 | GND | Power | Connect to ground. |
| 11 | CLK4 | Output | Low skew clock output. |
| 12 | CLK3 | Output | Low skew clock output. |
| 13 | CLK2 | Output | Low skew clock output. |
| 14 | CLK1 | Output | Low skew clock output. |
| 15 | VDDC | Power | Connect to +2.5 V, +3.3 V, or +5 V. Decouple to pin 10. |
| 16 | SELPECL | Input | Selects PECL or CMOS input. See table above. Internal pull-up to VDDP. |

External Components

The ICS558-01 requires two 0.01 μF capacitors between VDDP and GND, and VDDC and GND—one on each side of the chip. These must be close to the chip to minimize lead inductance. Series termination resistors of 33 Ω can be used on the outputs (these also must be close to the chip).

Absolute Maximum Ratings

Stresses above the ratings listed below can cause permanent damage to the ICS558-01. These ratings, which are standard values for IDT commercially rated parts, are stress ratings only. Functional operation of the device at these or any other conditions above those indicated in the operational sections of the specifications is not implied. Exposure to absolute maximum rating conditions for extended periods can affect product reliability. Electrical parameters are guaranteed only over the recommended operating temperature range.

| Item | Rating |
|---|---------------------|
| Supply Voltage; VDDP, VDDC (referenced to ground) | 7.0 V |
| Inputs and Clock Outputs (referenced to ground) | -0.5 V to VDD+0.5 V |
| Ambient Operating Temperature | 0 to +70 °C |
| Storage Temperature | -65 to +150 °C |
| Soldering Temperature (maximum of 10 seconds) | 260 °C |

DC Electrical Characteristics

VDDP = VDDC = 3.3V (unless stated otherwise), Ambient temperature 0 to +70 °C

| Parameter | Symbol | Conditions | Min. | Typ. | Max. | Units |
|------------------------------------|-----------------|---|----------------|------|----------------|-------|
| Operating Voltage, VDDP | | VDDP \geq VDDC | 3.0 | | 5.5 | V |
| Operating Voltage, VDDC | | VDDP \geq VDDC | 2.375 | | VDDP | V |
| Input High Voltage, CMOSIN | V _{IH} | | (VDDP/2)+ 1 | | | V |
| Input Low Voltage, CMOSIN | V _{IL} | | | | (VDDP/2)- 1 | V |
| Input High Voltage | V _{IH} | non-clock pins | VDDP-0.5 | | VDDP | V |
| Input Low Voltage | V _{IL} | non-clock pins | | | 0.5 | V |
| Common Mode Range, PECLIN | | VDDP=5 V | VDDP-3.7 | | VDDP-0.6 | V |
| Common Mode Range, PECLIN | | VDDP=3.3 V | VDDP-2.0 | | VDDP-0.6 | V |
| Peak-to-Peak Input Voltage, PECLIN | | | 0.3 | | 1.0 | V |
| Output High Voltage | V _{OH} | VDDC = 5 V, I _{OH} = -24 mA | VDDC-0.4 | | | V |
| Output Low Voltage | V _{OL} | VDDC = 5 V, I _{OL} = 24 mA | | | 0.4 | V |
| Output High Voltage | V _{OH} | VDDC = 3.3 V, I _{OH} = -18 mA | VDDC-0.4 | | | V |
| Output Low Voltage | V _{OL} | VDDC = 3.3 V, I _{OL} = 18 mA | | | 0.4 | V |

| Parameter | Symbol | Conditions | Min. | Typ. | Max. | Units |
|--------------------------|----------|-----------------------------------|----------|------|------|------------|
| Output High Voltage | V_{OH} | VDDC = 2.5 V, $I_{OH} = -8$ mA | VDDC-0.4 | | | V |
| Output Low Voltage | V_{OL} | VDDC = 2.5 V $I_{OL} = 8$ mA | | | 0.4 | V |
| Operating Supply Current | IDDP | No load, 100 MHz input | | 22 | | mA |
| Operating Supply Current | IDDC | No load, 100 MHz input | | 18 | | mA |
| Short Circuit Current | | | | +70 | | mA |
| On-chip pull-up resistor | R_{PU} | | | 250 | | k Ω |
| Input Capacitance | C_{IN} | | | 4 | | pF |

AC Electrical Characteristics

VDDP = VDDC = 3.3 V (unless stated otherwise), Ambient Temperature 0 to +70 °C

| Parameter | Symbol | Conditions | Min. | Typ. | Max. | Units |
|---------------------------------------|----------|---|------|------|------|-------|
| Input Frequency | | | 0 | | 250 | MHz |
| Output Rise Time | t_{OR} | | | | 800 | ps |
| Output Fall Time | t_{OF} | | | | 750 | ps |
| Skew, between any output clocks | | (Assumes identically loaded outputs with identical rise times, measured at VDDC/2) | | 0 | 250 | ps |
| Propagation Delay | | /1 | | 5.0 | | ns |
| | | /2 | | 6.0 | | ns |
| | | /3 | | | | ns |
| | | /4 | | 7.0 | | ns |
| Output Clock Duty Cycle for /2 and /4 | | | 45 | 50 | 55 | % |
| Output Clock Duty Cycle for /1 and /3 | | | 45 | 50 | 55 | % |

Thermal Characteristics (16-pin TSSOP)

| Parameter | Symbol | Conditions | Min. | Typ. | Max. | Units |
|--|---------------|----------------|------|------|------|-------|
| Thermal Resistance Junction to Ambient | θ_{JA} | Still air | | 78 | | °C/W |
| | θ_{JA} | 1 m/s air flow | | 70 | | °C/W |
| | θ_{JA} | 3 m/s air flow | | 68 | | °C/W |
| Thermal Resistance Junction to Case | θ_{JC} | | | 37 | | °C/W |

Package Outline and Package Dimensions (16-pin TSSOP, 4.40 mm Body, 0.65 mm Pitch)

Package dimensions are kept current with JEDEC Publication No. 95, MO-153

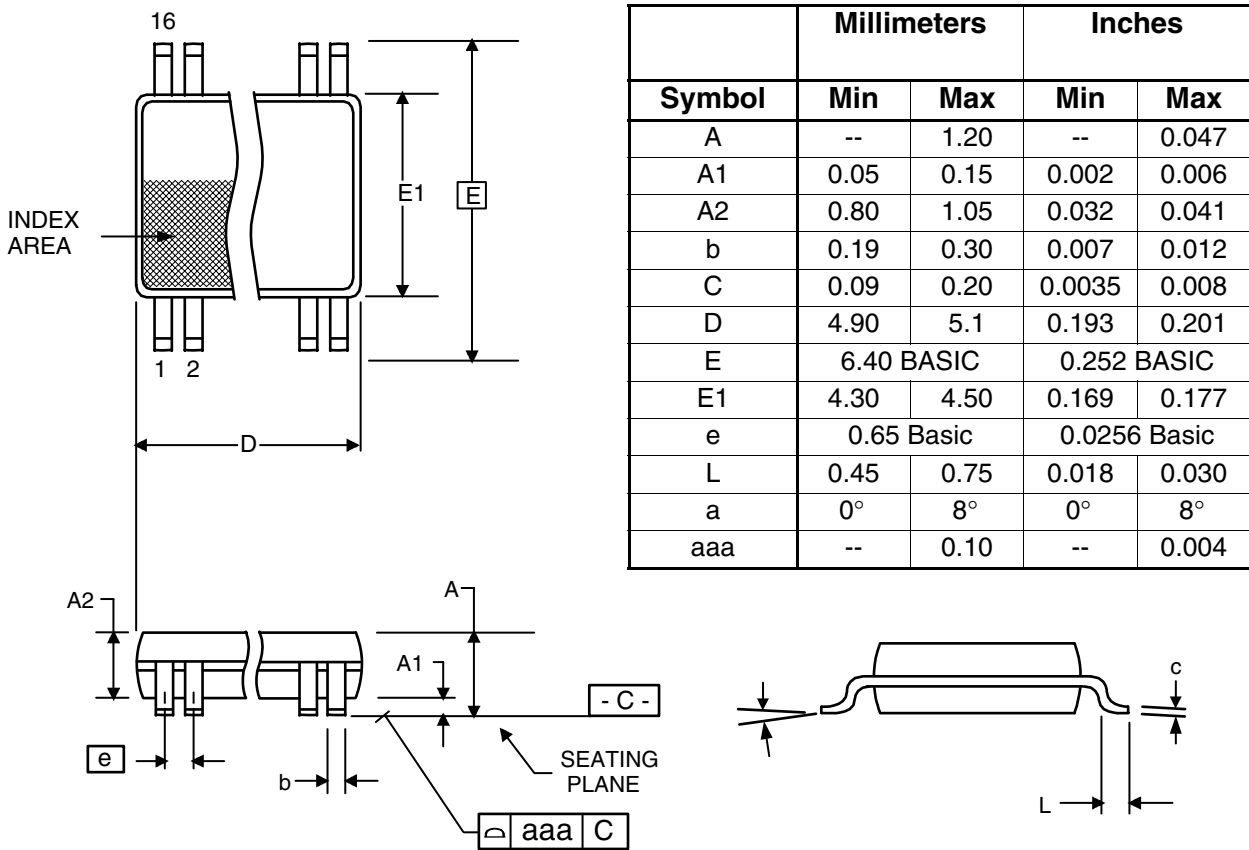

Ordering Information

| Part / Order Number | Marking | Shipping Packaging | Package | Temperature |
|---------------------|-----------|--------------------|--------------|-------------|
| 558G-01LF | 558G-01LF | Tubes | 16-pin TSSOP | 0 to +70° C |
| 558G-01LFT | 558G-01LF | Tape and Reel | 16-pin TSSOP | 0 to +70° C |

"LF" suffix to the part number are the Pb-Free configuration and are RoHS compliant.

While the information presented herein has been checked for both accuracy and reliability, Integrated Device Technology (IDT) assumes no responsibility for either its use or for the infringement of any patents or other rights of third parties, which would result from its use. No other circuits, patents, or licenses are implied. This product is intended for use in normal commercial applications. Any other applications such as those requiring extended temperature range, high reliability, or other extraordinary environmental requirements are not recommended without additional processing by IDT. IDT reserves the right to change any circuitry or specifications without notice. IDT does not authorize or warrant any IDT product for use in life support devices or critical medical instruments.

IMPORTANT NOTICE AND DISCLAIMER

RENESAS ELECTRONICS CORPORATION AND ITS SUBSIDIARIES (“RENESAS”) PROVIDES TECHNICAL SPECIFICATIONS AND RELIABILITY DATA (INCLUDING DATASHEETS), DESIGN RESOURCES (INCLUDING REFERENCE DESIGNS), APPLICATION OR OTHER DESIGN ADVICE, WEB TOOLS, SAFETY INFORMATION, AND OTHER RESOURCES “AS IS” AND WITH ALL FAULTS, AND DISCLAIMS ALL WARRANTIES, EXPRESS OR IMPLIED, INCLUDING, WITHOUT LIMITATION, ANY IMPLIED WARRANTIES OF MERCHANTABILITY, FITNESS FOR A PARTICULAR PURPOSE, OR NON-INFRINGEMENT OF THIRD PARTY INTELLECTUAL PROPERTY RIGHTS.

These resources are intended for developers skilled in the art designing with Renesas products. You are solely responsible for (1) selecting the appropriate products for your application, (2) designing, validating, and testing your application, and (3) ensuring your application meets applicable standards, and any other safety, security, or other requirements. These resources are subject to change without notice. Renesas grants you permission to use these resources only for development of an application that uses Renesas products. Other reproduction or use of these resources is strictly prohibited. No license is granted to any other Renesas intellectual property or to any third party intellectual property. Renesas disclaims responsibility for, and you will fully indemnify Renesas and its representatives against, any claims, damages, costs, losses, or liabilities arising out of your use of these resources. Renesas' products are provided only subject to Renesas' Terms and Conditions of Sale or other applicable terms agreed to in writing. No use of any Renesas resources expands or otherwise alters any applicable warranties or warranty disclaimers for these products.

(Rev.1.0 Mar 2020)

Corporate Headquarters

TOYOSU FORESIA, 3-2-24 Toyosu,
Koto-ku, Tokyo 135-0061, Japan
www.renesas.com

Contact Information

For further information on a product, technology, the most up-to-date version of a document, or your nearest sales office, please visit:
www.renesas.com/contact/

Trademarks

Renesas and the Renesas logo are trademarks of Renesas Electronics Corporation. All trademarks and registered trademarks are the property of their respective owners.

X-ON Electronics

Largest Supplier of Electrical and Electronic Components

Click to view similar products for [Clock Drivers & Distribution](#) category:

Click to view products by [Renesas](#) manufacturer:

Other Similar products are found below :

[8501BYLF](#) [P9090-0NLGI8](#) [854110AKILF](#) [83210AYLF](#) [NB6VQ572MMNG](#) [HMC6832ALP5LETR](#) [RS232-S5](#) [6ES7390-1AF30-0AA0](#)
[CDCVF2505IDRQ1](#) [LV5609LP-E](#) [NB7L572MNR4G](#) [SY100EP33VKG](#) [HMC7043LP7FETR](#) [ISPPAC-CLK5520V-01T100C](#) [EC4P-221-](#)
[MRXD1](#) [6EP1332-1SH71](#) [6ES7222-1BH32-0XB0](#) [6ES7231-4HD32-0XB0](#) [AD246JN](#) [AD246JY](#) [AD9510BCPZ](#) [AD9510BCPZ-REEL7](#)
[AD9511BCPZ](#) [AD9511BCPZ-REEL7](#) [AD9512BCPZ](#) [AD9512UCPZ-EP](#) [AD9513BCPZ](#) [AD9514BCPZ](#) [AD9514BCPZ-REEL7](#)
[AD9515BCPZ](#) [AD9515BCPZ-REEL7](#) [AD9572ACPZLVD](#) [AD9572ACPZPEC](#) [AD9513BCPZ-REEL7](#) [ADCLK950BCPZ-REEL7](#)
[ADCLK950BCPZ](#) [AD9553BCPZ](#) [HMC940LC4B](#) [HMC6832ALP5LE](#) [CSPUA877ABVG8](#) [9P936AFLFT](#) [49FCT3805ASOG](#)
[49FCT3805DQGI](#) [49FCT3805EQGI](#) [49FCT805CTQG](#) [74FCT3807EQGI](#) [74FCT388915TEPYG](#) [853S013AMILF](#) [853S058AGILF](#)
[8SLVD1208-33NBGI](#)