

Description

The ICS601-02 is a low cost, low phase noise, high performance clock synthesizer for any application that requires low phase noise and low jitter. The ICS601 is IDT's lowest phase noise multiplier. Using IDT's patented analog and digital Phase Locked Loop (PLL) techniques, the chip accepts a 10–27 MHz crystal or clock input, and produces output clocks up to 170 MHz at 3.3 V. A separate supply pin is provided so that the output can be 2.5 V.

This product is intended for clock generation. It has low output jitter (variation in the output period), but input to output skew and jitter are not defined nor guaranteed. For applications which require defined input to output timing, use the ICS670-01.

Features

- Packaged in 16-pin SOIC (Pb free)
- Uses fundamental 10 - 27 MHz crystal or clock
- Patented PLL with the lowest phase noise
- Output clocks up to 170 MHz at 3.3 V
- Output Enable function tri-states output
- Low phase noise: -132 dBc/Hz at 10 kHz
- Low jitter - 18 ps one sigma
- Full swing CMOS outputs with 25 mA drive capability at TTL levels
- Advanced, low power, sub-micron CMOS process
- Industrial temperature range (-40 to +85°C)
- 3.3 V or 5 V core VDD. Output clock can operate down to 2.5 V

Block Diagram

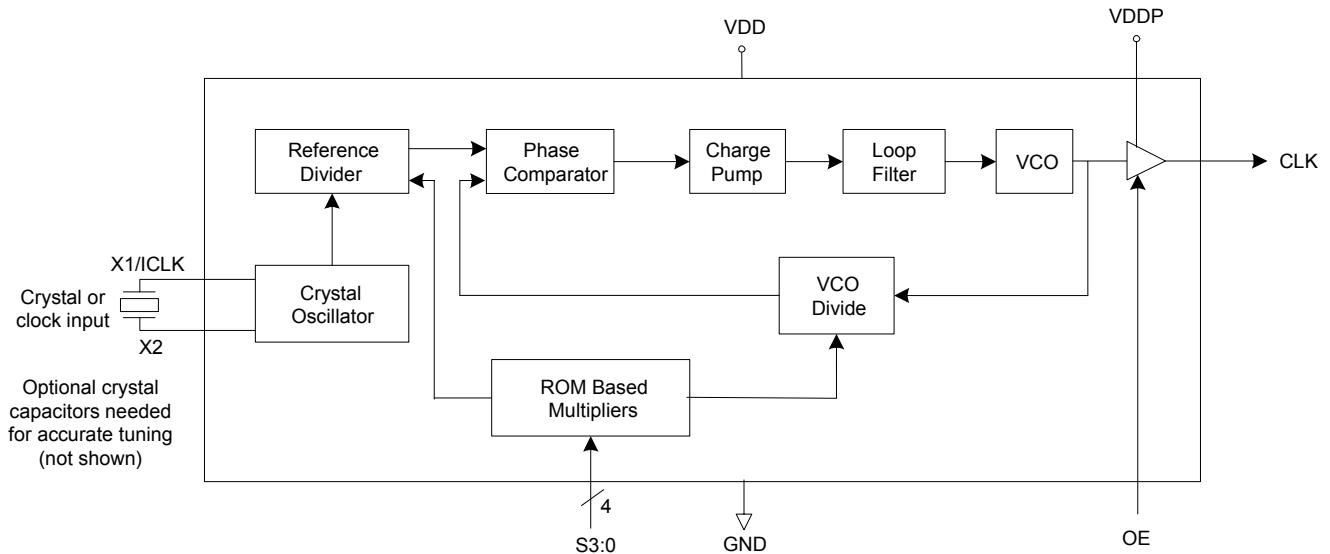

Pin Assignment

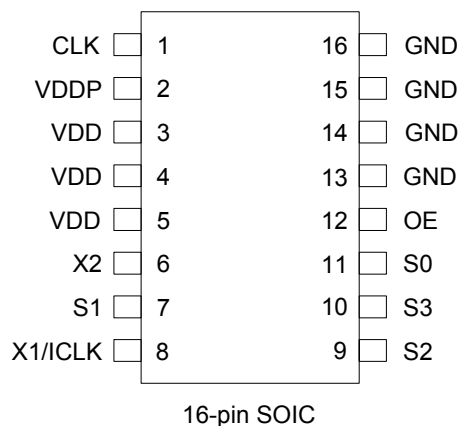

Multiplier Select Table

S3	S2	S1	S0	CLK
0	0	0	0	Input x4/3
0	0	0	1	Input x4
0	0	1	0	Input x25/4
0	0	1	1	Input x3
0	1	0	0	Input x7.5
0	1	0	1	Input x5
0	1	1	0	Input x6
0	1	1	1	Input x8
1	0	0	0	Input x8/3
1	0	0	1	Input x8
1	0	1	0	Input x12.5
1	0	1	1	Input x6
1	1	0	0	Input x15
1	1	0	1	Input x10
1	1	1	0	Input x12
1	1	1	1	Input x16

0 = connect directly to ground

1 = connect directly to VDD

Pin Descriptions

Pin Number	Pin Name	Pin Type	Pin Description
1	CLK	Output	Clock output from VCO. Output frequency equals the input frequency times multiplier.
2	VDDP	Power	Supply pin for CLK output buffer. Sets output clock amplitude. Connect to 2.5V or 3.3V.
3	VDD	Power	Connect to +3.3V or +5V. Must match other VDDs.
4	VDD	Power	Connect to +3.3V or +5V. Must match other VDDs.
5	VDD	Power	Connect to +3.3V or +5V. Must match other VDDs.
6	X2	XO	Crystal connection. Connect to a 10 - 27 MHz fundamental parallel mode crystal.
7	S1	Input	Multiplier select pin 1. Determines CLK output per table above. Internal pull-up.
8	X1/ICLK	XI	Crystal connection. Connect to a 10-27 MHz fundamental parallel mode crystal, or clock.
9	S2	Input	Multiplier select pin 2. Determines CLK output per table above. Internal pull-up.
10	S3	Input	Multiplier select pin 3. Determines CLK output per table above. Internal pull-up.
11	S0	Input	Multiplier select pin 0. Determines CLK output per table above. Internal pull-up.
12	OE	Input	Output Enable. Tri-states the output clock when low. Internal pull-up.
13	GND	Power	Connect to ground.
14	GND	Power	Connect to ground.
15	GND	Power	Connect to ground.
16	GND	Power	Connect to ground.

Achieving Low Phase Noise

Figure 1 shows a typical phase noise measurement in a 125 MHz system. There are a few simple steps that can be taken to achieve these levels of phase noise from the ICS601-02. Variations in VDD will increase the phase noise, so it is important to have a stable, low noise supply voltage at the device. Use decoupling capacitors of 0.1 μF in parallel with 0.01 μF . It is important to have these capacitors as close as possible to the ICS601-02 supply pins. Disabling the REFOUT clock is also important for achieving low phase noise; lab tests have shown that this can reduce the phase noise by as much as 10 dBc/Hz.

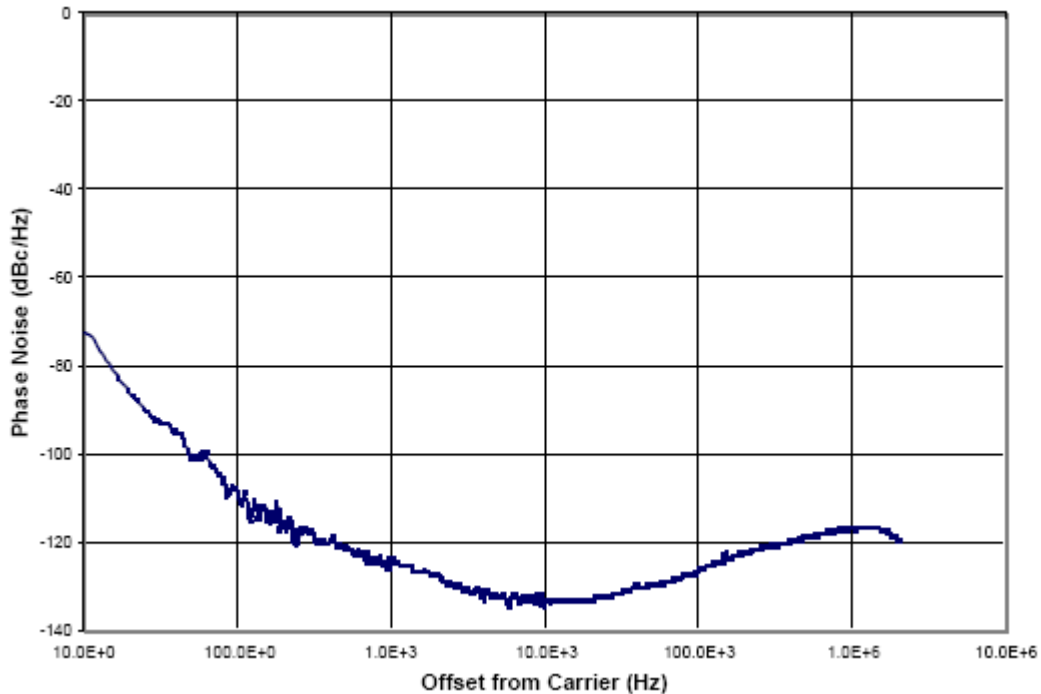

Figure 1: Phase Noise of ICS601-02 at 125 MHz out, 25 MHz crystal input, VDD=3.3 V.

External Components

The ICS601-02 requires a minimum number of external components for proper operation. Decoupling capacitors of 0.01 μF and 0.1 μF should be connected between VDD and GND, as close to the part as possible. A series termination resistor of 33 Ω may be used for the clock output. The crystal must be connected as close to the chip as possible. The crystal should be fundamental mode, parallel resonant. Do not use third overtone. For exact tuning when using a crystal, capacitors should be connected from pins X1 to ground and X2 to ground. In general, the value of these capacitors is given by the following equation, where CL is the crystal load capacitance: Crystal caps (pF) = (CL-5) x 2. So for a crystal with 16 pF load capacitance, two 22 pF caps can be used.

Absolute Maximum Ratings

Stresses above the ratings listed below can cause permanent damage to the ICS601-02. These ratings, which are standard values for IDT commercially rated parts, are stress ratings only. Functional operation of the device at these or any other conditions above those indicated in the operational sections of the specifications is not implied. Exposure to absolute maximum rating conditions for extended periods can affect product reliability. Electrical parameters are guaranteed only over the recommended operating temperature range.

Item	Rating
Supply Voltage, VDD (referenced to ground)	7 V
All Inputs and Outputs (referenced to ground)	-0.5 V to VDD+0.5 V
Storage Temperature	-65 to +150° C
Soldering Temperature	260° C
Ambient Operating Temperature (industrial)	-40 to +85° C

DC Electrical Characteristics

Unless stated otherwise, VDD = VDDP = 3.3 V, Ambient Temperature -40 to +85° C

Parameter	Symbol	Conditions	Min.	Typ.	Max.	Units
Operating Voltage	VDD		3.0		5.5	V
Output Buffer Voltage	VDDP		2.375		VDD	V
Input High Voltage	V _{IH}	XI/ICLK pin only, Note 1	(VDD/2)+1			V
Input Low Voltage	V _{IL}	XI/ICLK pin only, Note 1			(VDD/2)-1	V
Input High Voltage	V _{IH}		2			V
Input Low Voltage	V _{IL}				0.8	V
Output High Voltage, CMOS level	V _{OH}	I _{OH} = -4 mA	VDD-0.4			V
Output High Voltage	V _{OH}	I _{OH} = -12 mA	2.4			V
Output Low Voltage	V _{OL}	I _{OL} = 12 mA			0.4	V
Operating Supply Current	IDD	No load, 125 MHz		9	20	mA
Short Circuit Current	I _{OS}	Each output	±40	±60		mA
Input Capacitance	C _{IN}	OE, select pins		5		pF

Note 1: Switching occurs nominally at VDD/2.

AC Electrical Characteristics

Unless stated otherwise, $V_{DD} = V_{DDP} = 3.3\text{ V}$, Ambient Temperature -40 to $+85^{\circ}\text{C}$

Parameter	Symbol	Conditions	Min.	Typ.	Max.	Units
Input Frequency	f_{IN}		10		27	MHz
Output Frequency	f_{OUT}	At 3.3 V or 5 V			170	MHz
Output Clock Rise Time		0.8 to 2.0 V, no load			1.5	ns
Output Clock Fall Time		0.8 to 2.0 V, no load			1.5	ns
Output Clock Duty Cycle		At $V_{DD}/2$	45	50	55	%
Maximum Absolute Jitter, short term, 125 MHz		No load		± 50	± 75	ps
Maximum Jitter, one sigma, 125 MHz (x5)		No load		18	25	ps
Phase Noise, relative to carrier, 125 MHz (x5)		100 Hz offset		-108		dBc/Hz
Phase Noise, relative to carrier, 125 MHz (x5)		1 kHz offset		-123		dBc/Hz
Phase Noise, relative to carrier, 125 MHz (x5)		10 kHz offset		-132		dBc/Hz
Phase Noise, relative to carrier, 125 MHz (x5)		100 kHz offset		-125		dBc/Hz

Package Outline and Package Dimensions (16 pin SOIC, 150 Mil. Narrow Body)

Package dimensions are kept current with JEDEC Publication No. 95

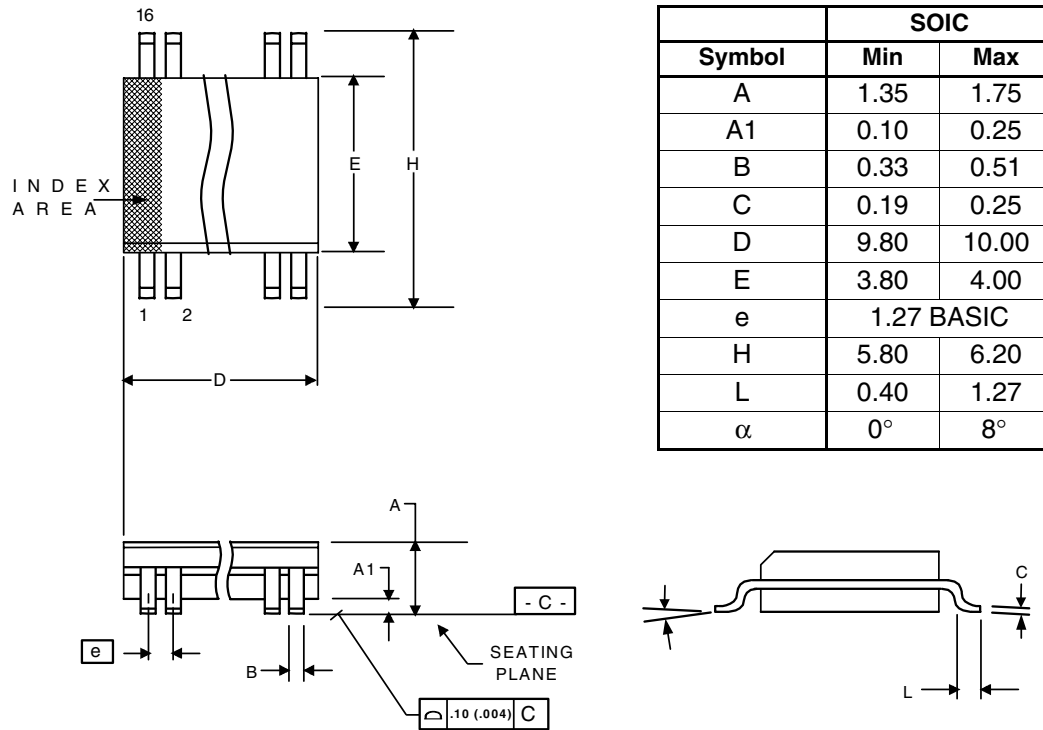

Ordering Information

Part / Order Number	Marking	Shipping Packaging	Package	Temperature
ICS601M-02ILF	601M-02ILF	Tubes	16-pin SOIC	-40 to +85° C
ICS601M-02ILFT	601M-02ILF	Tape and Reel	16-pin SOIC	-40 to +85° C

"LF" suffix to the part number are the Pb-Free configuration and are RoHS compliant.

While the information presented herein has been checked for both accuracy and reliability, Integrated Device Technology (IDT) assumes no responsibility for either its use or for the infringement of any patents or other rights of third parties, which would result from its use. No other circuits, patents, or licenses are implied. This product is intended for use in normal commercial applications. Any other applications such as those requiring extended temperature range, high reliability, or other extraordinary environmental requirements are not recommended without additional processing by IDT. IDT reserves the right to change any circuitry or specifications without notice. IDT does not authorize or warrant any IDT product for use in life support devices or critical medical instruments.

Revision History

Rev.	Originator	Date	Description of Change
E		02/10/09	Converted to IDT document template.
F		10/27/09	Added EOL note for non-green parts.
G		05/13/10	Removed EOL note and non-green parts

IMPORTANT NOTICE AND DISCLAIMER

RENESAS ELECTRONICS CORPORATION AND ITS SUBSIDIARIES (“RENESAS”) PROVIDES TECHNICAL SPECIFICATIONS AND RELIABILITY DATA (INCLUDING DATASHEETS), DESIGN RESOURCES (INCLUDING REFERENCE DESIGNS), APPLICATION OR OTHER DESIGN ADVICE, WEB TOOLS, SAFETY INFORMATION, AND OTHER RESOURCES “AS IS” AND WITH ALL FAULTS, AND DISCLAIMS ALL WARRANTIES, EXPRESS OR IMPLIED, INCLUDING, WITHOUT LIMITATION, ANY IMPLIED WARRANTIES OF MERCHANTABILITY, FITNESS FOR A PARTICULAR PURPOSE, OR NON-INFRINGEMENT OF THIRD PARTY INTELLECTUAL PROPERTY RIGHTS.

These resources are intended for developers skilled in the art designing with Renesas products. You are solely responsible for (1) selecting the appropriate products for your application, (2) designing, validating, and testing your application, and (3) ensuring your application meets applicable standards, and any other safety, security, or other requirements. These resources are subject to change without notice. Renesas grants you permission to use these resources only for development of an application that uses Renesas products. Other reproduction or use of these resources is strictly prohibited. No license is granted to any other Renesas intellectual property or to any third party intellectual property. Renesas disclaims responsibility for, and you will fully indemnify Renesas and its representatives against, any claims, damages, costs, losses, or liabilities arising out of your use of these resources. Renesas' products are provided only subject to Renesas' Terms and Conditions of Sale or other applicable terms agreed to in writing. No use of any Renesas resources expands or otherwise alters any applicable warranties or warranty disclaimers for these products.

(Rev.1.0 Mar 2020)

Corporate Headquarters

TOYOSU FORESIA, 3-2-24 Toyosu,
Koto-ku, Tokyo 135-0061, Japan
www.renesas.com

Contact Information

For further information on a product, technology, the most up-to-date version of a document, or your nearest sales office, please visit:
www.renesas.com/contact/

Trademarks

Renesas and the Renesas logo are trademarks of Renesas Electronics Corporation. All trademarks and registered trademarks are the property of their respective owners.

X-ON Electronics

Largest Supplier of Electrical and Electronic Components

Click to view similar products for [Clock Generators & Support Products](#) category:

Click to view products by [Renesas](#) manufacturer:

Other Similar products are found below :

[CV183-2TPAG](#) [950810CGLF](#) [9DBV0741AKILF](#) [9VRS4420DKLF](#) [CY25404ZXI226](#) [CY25422SXI-004](#) [MPC9893AE](#) [NB3H5150-01MNTXG](#) [PL602-20-K52TC](#) [ICS557GI-03LF](#) [PI6LC48P0101LIE](#) [82P33814ANLG](#) [840021AGLF](#) [ZL30244LFG7](#) [PI6LC48C21LE](#) [ZL30245LFG7](#) [PI6LC48P0405LIE](#) [PI6LC48P03LE](#) [MAX24505EXG+](#) [ZL30163GDG2](#) [5L1503L-000NVGI8](#) [ZL30673LFG7](#) [MAX24188ETK2](#) [ZL30152GGG2](#) [5L1503-000NVGI8](#) [PI6C557-01BZHIEX](#) [PI6LC48C21LIE](#) [CY2542QC002](#) [5P35023-106NLGI](#) [5X1503L-000NLGI8](#) [ZL30121GGG2V2](#) [ZL30282LDG1](#) [ZL30102QDG1](#) [ZL30159GGG2](#) [DS1070K](#) [ZL30145GGG2](#) [ZL30312GKG2](#) [MAX24405EXG2](#) [ZL30237GGG2](#) [SY100EL34LZG](#) [AD9518-4ABCPZ](#) [MX852BB0030](#) [PI6LC4840ZHE](#) [AD9516-0BCPZ-REEL7](#) [AD9574BCPZ-REEL7](#) [PL602-21TC-R](#) [ZL30105QDG1](#) [ZL30100QDG1](#) [ZL30142GGG2](#) [ZL30250LDG1](#)