

**Features**

- ◆ 128K x 8 advanced high-speed CMOS static RAM
- ◆ JEDEC revolutionary pinout (center power/GND) for reduced noise
- ◆ Equal access and cycle times
  - Commercial: 10/12/15ns
  - Industrial: 10/12/15ns
- ◆ One Chip Select plus one Output Enable pin
- ◆ Inputs and outputs are LVTTTL-compatible
- ◆ Single 3.3V supply
- ◆ Low power consumption via chip deselect
- ◆ Available in a 32-pin 300- and 400-mil Plastic SOJ, and 32-pin Type II TSOP packages
- ◆ Industrial temperature range (-40°C to +85°C) is available for selected speeds
- ◆ Green parts available, see ordering information

**Description**

The IDT71V124 is a 1,048,576-bit high-speed static RAM organized as 128K x 8. It is fabricated using high-performance, high-reliability CMOS technology. This state-of-the-art technology, combined with innovative circuit design techniques, provides a cost-effective solution for high-speed memory needs. The JEDEC center power/GND pinout reduces noise generation and improves system performance.

The IDT71V124 has an output enable pin which operates as fast as 5ns, with address access times as fast as 10ns available. All bidirectional inputs and outputs of the IDT71V124 are LVTTTL-compatible and operation is from a single 3.3V supply. Fully static asynchronous circuitry is used; no clocks or refreshes are required for operation.

**Functional Block Diagram**

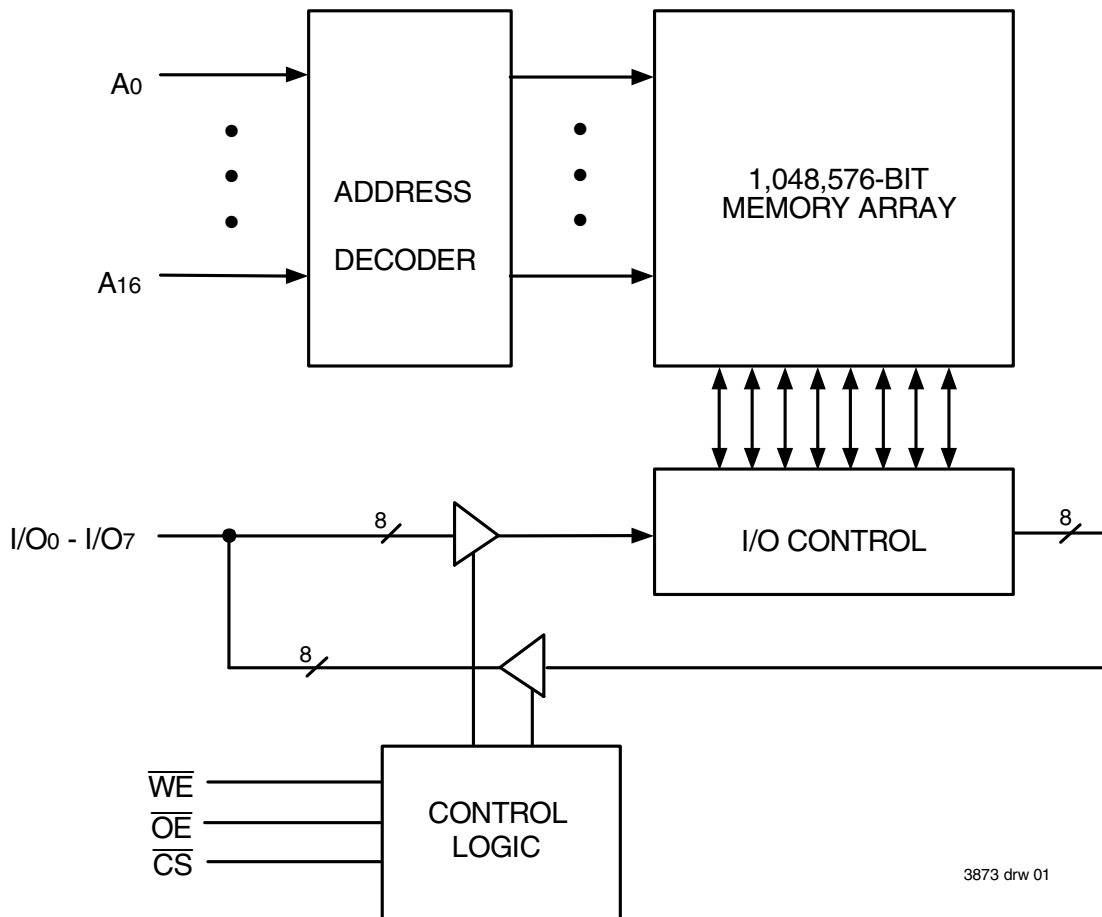

3873 drw 01

## Pin Configurations<sup>(1)</sup>

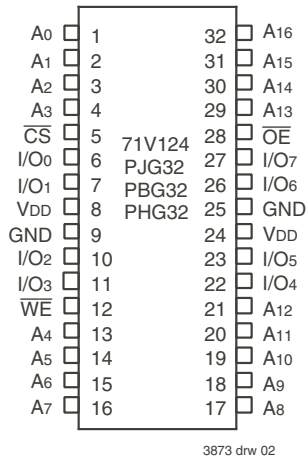

### SOJ and TSOP Top View

**NOTE:**

- This text does not indicate orientation of actual part-marking.

## Truth Table<sup>(1)</sup>

$\overline{CS}$	$\overline{OE}$	$\overline{WE}$	I/O	Function
L	L	H	DATAOUT	Read Data
L	X	L	DATAIN	Write Data
L	H	H	High-Z	Output Disabled
H	X	X	High-Z	Deselected – Standby

3873 tbl 01

**NOTE:**

- H =  $V_{IH}$ , L =  $V_{IL}$ , X = Don't care.

## Capacitance

( $T_A = +25^\circ\text{C}$ ,  $f = 1.0\text{MHz}$ , SOJ package)

Symbol	Parameter <sup>(1)</sup>	Conditions	Max.	Unit
$C_{IN}$	Input Capacitance	$V_{IN} = 3\text{dV}$	6	pF
$C_{I/O}$	I/O Capacitance	$V_{OUT} = 3\text{dV}$	7	pF

3873 tbl 03

**NOTE:**

- This parameter is guaranteed by device characterization, but is not production tested.

## DC Electrical Characteristics

( $V_{DD} = \text{Min. to Max.}$ , Commercial and Industrial Temperature Ranges)

Symbol	Parameter	Test Conditions	Min.	Max.	Unit
$ I_{LI} $	Input Leakage Current	$V_{DD} = \text{Max.}$ , $V_{IN} = \text{GND to } V_{DD}$	—	5	$\mu\text{A}$
$ I_{LO} $	Output Leakage Current	$V_{DD} = \text{Max.}$ , $\overline{CS} = V_{IH}$ , $V_{OUT} = \text{GND to } V_{DD}$	—	5	$\mu\text{A}$
$V_{OL}$	Output Low Voltage	$I_{OL} = 8\text{mA}$ , $V_{DD} = \text{Min.}$	—	0.4	V
$V_{OH}$	Output High Voltage	$I_{OH} = -4\text{mA}$ , $V_{DD} = \text{Min.}$	2.4	—	V

3873 tbl 05

## Absolute Maximum Ratings<sup>(1)</sup>

Symbol	Rating	Value	Unit
$V_{DD}$	Supply Voltage Relative to GND	-0.5 to +4.6	V
$V_{IN}$ , $V_{OUT}$	Terminal Voltage Relative to GND	-0.5 to $V_{DD}+0.5$	V
$T_A$	Commercial Operating Temperature	-0 to +70	$^\circ\text{C}$
	Industrial Operating Temperature	-40 to +85	
$T_{BIAS}$	Temperature Under Bias	-55 to +125	$^\circ\text{C}$
$T_{STG}$	Storage Temperature	-55 to +125	$^\circ\text{C}$
$P_T$	Power Dissipation	1.25	W
$I_{OUT}$	DC Output Current	50	mA

**NOTE:**

3873 tbl 02

- Stresses greater than those listed under ABSOLUTE MAXIMUM RATINGS may cause permanent damage to the device. This is a stress rating only and functional operation of the device at these or any other conditions above those indicated in the operational sections of this specification is not implied. Exposure to absolute maximum rating conditions for extended periods may affect reliability.

## Recommended Operating Temperature and Supply Voltage

Grade	Temperature	GND	$V_{DD}$
Commercial	$0^\circ\text{C to } +70^\circ\text{C}$	0V	See Below
Industrial	$-40^\circ\text{C to } +85^\circ\text{C}$	0V	See Below

3873 tbl 02a

## Recommended DC Operating Conditions

Symbol	Parameter	Min.	Typ.	Max.	Unit
$V_{DD}^{(1)}$	Supply Voltage	3.15	3.3	3.6	V
$V_{DD}^{(2)}$	Supply Voltage	3.0	3.3	3.6	V
$V_{SS}$	Ground	0	0	0	V
$V_{IH}$	Input High Voltage	2.0	—	$V_{DD}+0.3^{(3)}$	V
$V_{IL}$	Input Low Voltage	-0.5 <sup>(1)</sup>	—	0.8	V

3873 tbl 04

**NOTES:**

- For 71V124SA10 only.
- For all speed grades except 71V124SA10.
- $V_{IH}(\text{max.}) = V_{DD}+2\text{V}$  for pulse width less than 5ns, once per cycle.
- $V_{IL}(\text{min.}) = -2\text{V}$  for pulse width less than 5ns, once per cycle.

## DC Electrical Characteristics<sup>(1, 2)</sup>

(V<sub>DD</sub> = Min. to Max., V<sub>LC</sub> = 0.2V, V<sub>HC</sub> = V<sub>DD</sub> - 0.2V)

Symbol	Parameter	71V124SA10	71V124SA12		71V124SA15		Unit
		Commercial	Com'l	Ind	Com'l	Ind	
I <sub>CC</sub>	Dynamic Operating Current CS ≤ V <sub>LC</sub> , Outputs Open, V <sub>DD</sub> = Max., f = f <sub>MAX</sub> <sup>(3)</sup>	145	130	140	100	120	mA
I <sub>SB</sub>	Dynamic Standby Power Supply Current CS ≥ V <sub>HC</sub> , Outputs Open, V <sub>DD</sub> = Max., f = f <sub>MAX</sub> <sup>(3)</sup>	45	40	40	35	40	mA
I <sub>SB1</sub>	Full Standby Power Supply Current (static) CS ≥ V <sub>HC</sub> , Outputs Open, V <sub>DD</sub> = Max., f = 0 <sup>(3)</sup>	10	10	10	10	10	mA

**NOTES:**

- All values are maximum guaranteed values.
- All inputs switch between 0.2V (Low) and V<sub>DD</sub>-0.2V (High).
- f<sub>MAX</sub> = 1/trc (all address inputs are cycling at f<sub>MAX</sub>); f = 0 means no address input lines are changing.

3873 tbl 06

## AC Test Conditions

Input Pulse Levels	GND to 3.0V
Input Rise/Fall Times	3ns
Input Timing Reference Levels	1.5V
Output Reference Levels	1.5V
AC Test Load	See Figure 1 and 2

3873 tbl 07

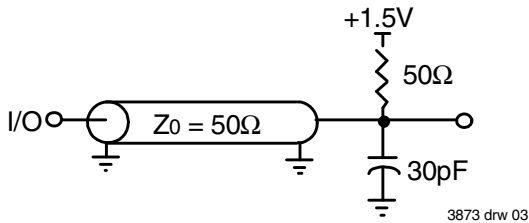
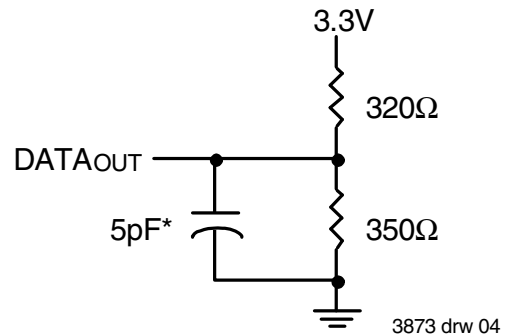

Figure 1. AC Test Load



\*Including jig and scope capacitance.

Figure 2. AC Test Load  
(for t<sub>CLZ</sub>, t<sub>OLZ</sub>, t<sub>CHZ</sub>, t<sub>OHZ</sub>, t<sub>OW</sub>, and t<sub>WHZ</sub>)

## AC Electrical Characteristics

(VDD = Min. to Max., Commercial and Industrial Temperature Ranges)

Symbol	Parameter	71V124SA10		71V124SA12		71V124SA15		Unit
		Min.	Max.	Min.	Max.	Min.	Max.	
<b>READ CYCLE</b>								
t <sub>RC</sub>	Read Cycle Time	10	—	12	—	15	—	ns
t <sub>AA</sub>	Address Access Time	—	10	—	12	—	15	ns
t <sub>ACS</sub>	Chip Select Access Time	—	10	—	12	—	15	ns
t <sub>CLZ</sub> <sup>(1)</sup>	Chip Select to Output in Low-Z	4	—	4	—	4	—	ns
t <sub>CHZ</sub> <sup>(1)</sup>	Chip Deselect to Output in High-Z	0	5	0	6	0	7	ns
t <sub>OE</sub>	Output Enable to Output Valid	—	5	—	6	—	7	ns
t <sub>OLZ</sub> <sup>(1)</sup>	Output Enable to Output in Low-Z	0	—	0	—	0	—	ns
t <sub>OHZ</sub> <sup>(1)</sup>	Output Disable to Output in High-Z	0	5	0	5	0	5	ns
t <sub>OH</sub>	Output Hold from Address Change	4	—	4	—	4	—	ns
<b>WRITE CYCLE</b>								
t <sub>WC</sub>	Write Cycle Time	10	—	12	—	15	—	ns
t <sub>AW</sub>	Address Valid to End-of-Write	7	—	8	—	10	—	ns
t <sub>CW</sub>	Chip Select to End-of-Write	7	—	8	—	10	—	ns
t <sub>AS</sub>	Address Set-up Time	0	—	0	—	0	—	ns
t <sub>WP</sub>	Write Pulse Width	7	—	8	—	10	—	ns
t <sub>WR</sub>	Write Recovery Time	0	—	0	—	0	—	ns
t <sub>DW</sub>	Data Valid to End-of-Write	5	—	6	—	7	—	ns
t <sub>DH</sub>	Data Hold Time	0	—	0	—	0	—	ns
t <sub>OW</sub> <sup>(2)</sup>	Output Active from End-of-Write	3	—	3	—	3	—	ns
t <sub>WHZ</sub> <sup>(2)</sup>	Write Enable to Output in High-Z	0	5	0	5	0	5	ns

3873 tbl 08

**NOTES:**

1. This parameter guaranteed with the AC load (Figure 2) by device characterization, but is not production tested.

### Timing Waveform of Read Cycle No. 1<sup>(1)</sup>

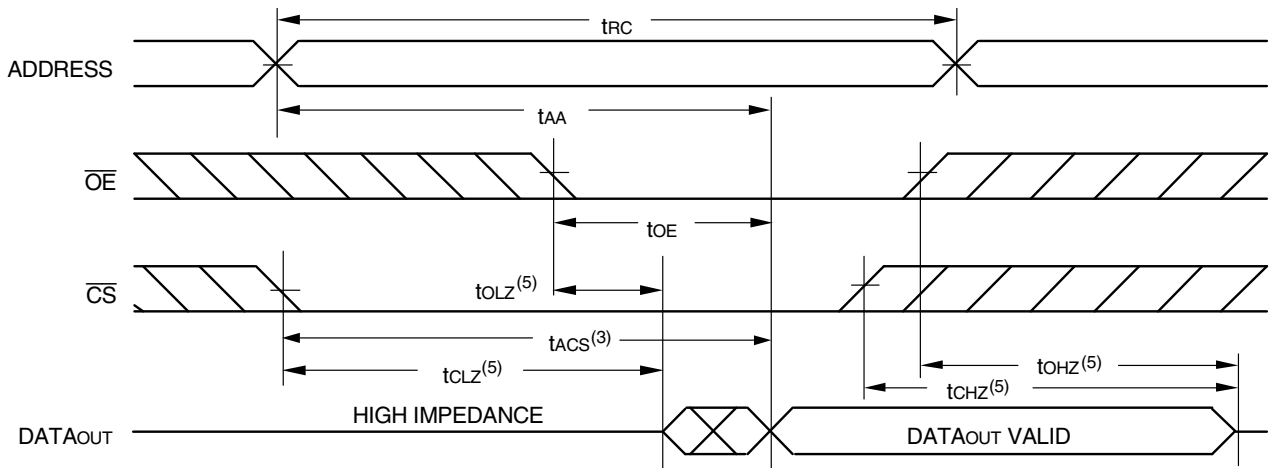

3873 drw 05

### Timing Waveform of Read Cycle No. 2<sup>(1, 2, 4)</sup>

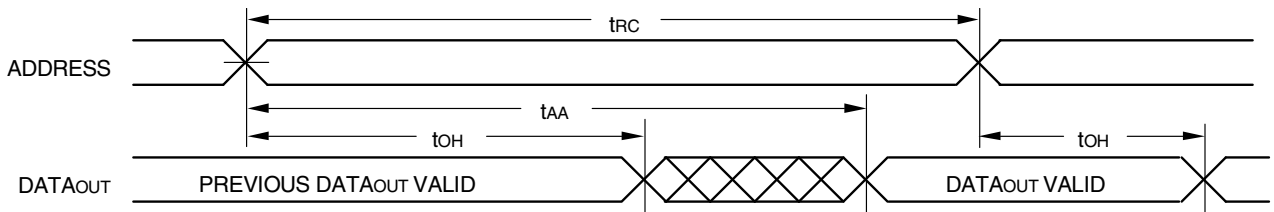

3873 drw 06

#### NOTES:

1.  $\overline{WE}$  is HIGH for Read Cycle.
2. Device is continuously selected,  $\overline{CS}$  is LOW.
3. Address must be valid prior to or coincident with the later of  $\overline{CS}$  transition LOW; otherwise  $t_{AA}$  is the limiting parameter.
4.  $\overline{OE}$  is LOW.
5. Transition is measured  $\pm 200\text{mV}$  from steady state.

### Timing Waveform of Write Cycle No. 1 ( $\overline{WE}$ Controlled Timing)<sup>(1,2,4)</sup>

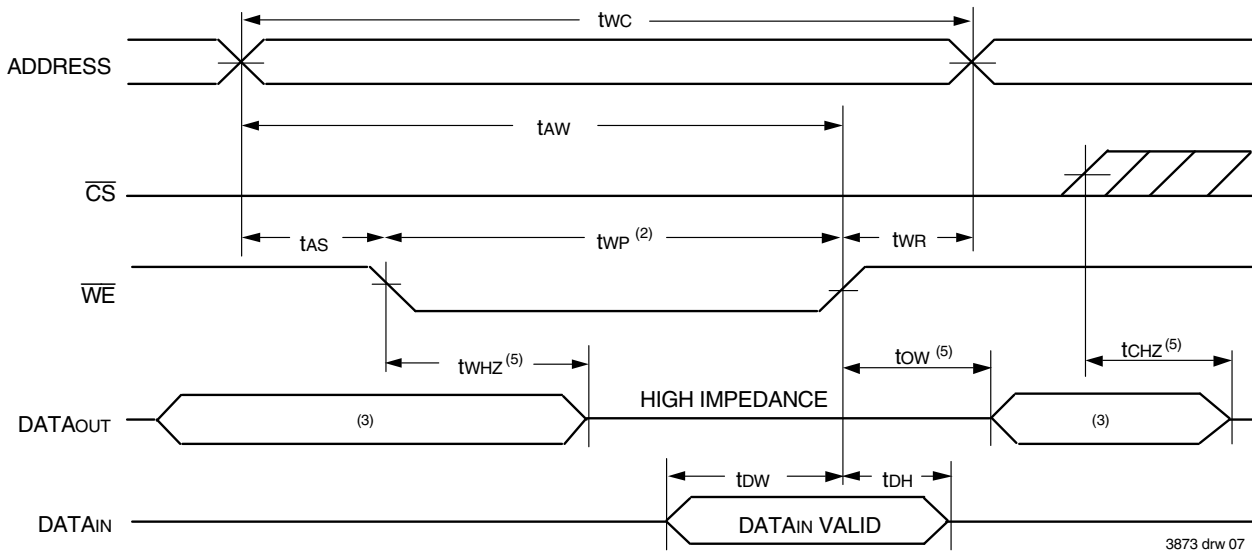

### Timing Waveform of Write Cycle No. 2 ( $\overline{CS}$ Controlled Timing)<sup>(1, 4)</sup>

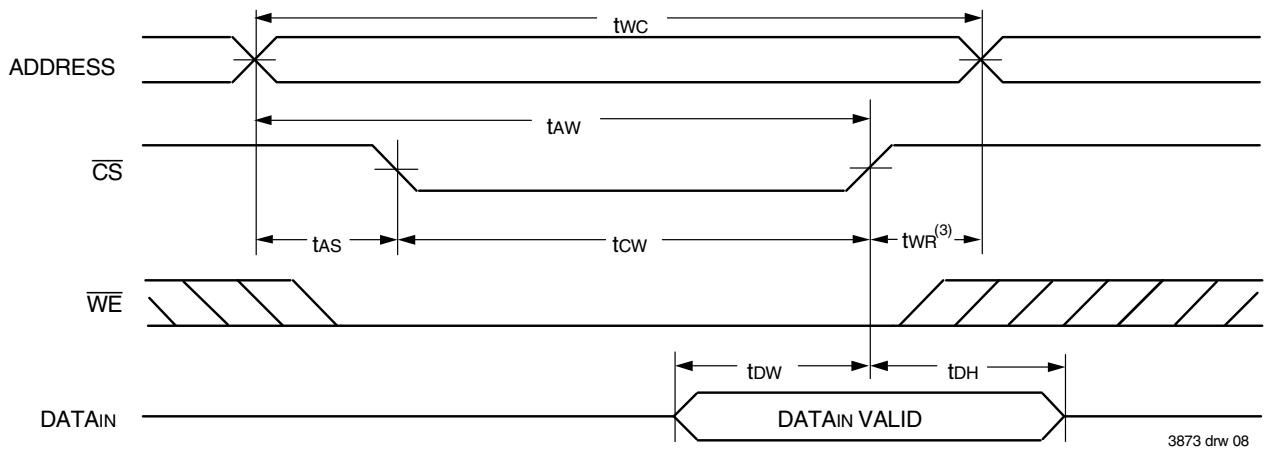

**NOTES:**

1. A write occurs during the overlap of a LOW  $\overline{CS}$  and a LOW  $\overline{WE}$ .
2.  $\overline{OE}$  is continuously HIGH. During a  $\overline{WE}$  controlled write cycle with  $\overline{OE}$  LOW, t<sub>WP</sub> must be greater than or equal to t<sub>WHZ</sub> + t<sub>OW</sub> to allow the I/O drivers to turn off and data to be placed on the bus for the required t<sub>DW</sub>. If  $\overline{OE}$  is HIGH during a  $\overline{WE}$  controlled write cycle, this requirement does not apply and the minimum write pulse is the specified t<sub>WP</sub>.
3. During this period, I/O pins are in the output state, and input signals must not be applied.
4. If the  $\overline{CS}$  LOW transition occurs simultaneously with or after the  $\overline{WE}$  LOW transition, the outputs remain in a high impedance state.  $\overline{CS}$  must be active during the t<sub>WP</sub> write period.
5. Transition is measured ±200mV from steady state.

## Ordering Information

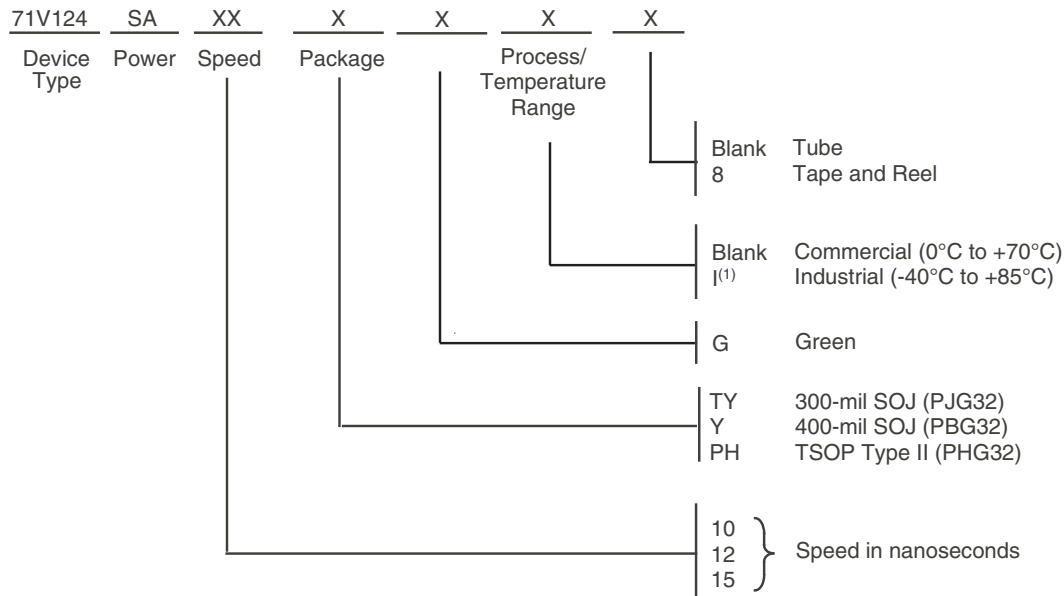

**NOTE:**

1. Contact your local sales office for industrial temp. range for other speeds, packages and powers.

3873 drw 09

## Orderable Part Information

Speed (ns)	Orderable Part ID	Pkg. Code	Pkg. Type	Temp. Grade
10	71V124SA10PHG	PHG32	TSOP	C
	71V124SA10PHG8	PHG32	TSOP	C
	71V124SA10PHGI	PHG32	TSOP	I
	71V124SA10PHGI8	PHG32	TSOP	I
	71V124SA10TYG	PJG32	SOJ	C
	71V124SA10TYG8	PJG32	SOJ	C
	71V124SA10YG	PBG32	SOJ	C
	71V124SA10YG8	PBG32	SOJ	C
12	71V124SA12PHG	PHG32	TSOP	C
	71V124SA12PHG8	PHG32	TSOP	C
	71V124SA12PHGI	PHG32	TSOP	I
	71V124SA12PHGI8	PHG32	TSOP	I
	71V124SA12TYG	PJG32	SOJ	C
	71V124SA12TYG8	PJG32	SOJ	C
	71V124SA12TYGI	PJG32	SOJ	I
	71V124SA12TYGI8	PJG32	SOJ	I
	71V124SA12YG	PBG32	SOJ	C
	71V124SA12YG8	PBG32	SOJ	C
	71V124SA12YGI	PBG32	SOJ	I
	71V124SA12YGI8	PBG32	SOJ	I

Speed (ns)	Orderable Part ID	Pkg. Code	Pkg. Type	Temp. Grade
15	71V124SA15PHG	PHG32	TSOP	C
	71V124SA15PHG8	PHG32	TSOP	C
	71V124SA15PHGI	PHG32	TSOP	I
	71V124SA15PHGI8	PHG32	TSOP	I
	71V124SA15TYG	PJG32	SOJ	C
	71V124SA15TYG8	PJG32	SOJ	C
	71V124SA15TYGI	PJG32	SOJ	I
	71V124SA15TYGI8	PJG32	SOJ	I
	71V124SA15YG	PBG32	SOJ	C
	71V124SA15YG8	PBG32	SOJ	C
	71V124SA15YGI	PBG32	SOJ	I
	71V124SA15YGI8	PBG32	SOJ	I

## Datasheet Document History

11/22/99		Updated to new format
	Pg. 1-4, 7	Added Industrial Temperature range offerings
	Pg. 2	Added Recommended Operating Temperature and Supply Voltage table
	Pg. 6	Revised footnotes on Write Cycle No. 1 diagram
	Pg. 8	Added Datasheet Document History
08/30/00	Pg. 3	Tighten Icc and Isb
	Pg. 4	Tighten AC Characteristics toHZ, toW and tWHZ
08/22/01	Pg. 7	Removed footnote "400-mil SOJ package only offered in 10ns and 12ns speed grade"
11/30/03	Pg. 1,3,7	Added Industrial temperature offering 10ns speed grade
01/30/04	Pg. 7	Added "Restricted hazardous substance device" to ordering information
2/14/07	Pg. 7	Added H generation die step to data sheet ordering information
10/13/08	Pg. 7	Removed "IDT" from the orderable part number
11/15/10	Pg. 1,3,4,7	Removed 20ns commercial, 10ns & 20ns industrial and also removed HSA offering
03/29/12	Pg. 7	Removed die step indicator from the ordering information Added tape and reel and green to the ordering information
02/19/13	Pg. 1	Removed IDT reference to fabrication and changed fastest access address time from 9ns to 10ns
03/10/17	Pg. 2	Updated pin configurations with correct package codes and with new IDT logo
06/30/20	Pg. 1 - 9	Rebranded as Renesas datasheet
	Pg. 2 & 7	Updated package codes
	Pg. 1 & 7	Updated Industrial temp range and green availability
	Pg. 7	Added Orderable Part Information table



## IMPORTANT NOTICE AND DISCLAIMER

RENESAS ELECTRONICS CORPORATION AND ITS SUBSIDIARIES (“RENESAS”) PROVIDES TECHNICAL SPECIFICATIONS AND RELIABILITY DATA (INCLUDING DATASHEETS), DESIGN RESOURCES (INCLUDING REFERENCE DESIGNS), APPLICATION OR OTHER DESIGN ADVICE, WEB TOOLS, SAFETY INFORMATION, AND OTHER RESOURCES “AS IS” AND WITH ALL FAULTS, AND DISCLAIMS ALL WARRANTIES, EXPRESS OR IMPLIED, INCLUDING, WITHOUT LIMITATION, ANY IMPLIED WARRANTIES OF MERCHANTABILITY, FITNESS FOR A PARTICULAR PURPOSE, OR NON-INFRINGEMENT OF THIRD PARTY INTELLECTUAL PROPERTY RIGHTS.

These resources are intended for developers skilled in the art designing with Renesas products. You are solely responsible for (1) selecting the appropriate products for your application, (2) designing, validating, and testing your application, and (3) ensuring your application meets applicable standards, and any other safety, security, or other requirements. These resources are subject to change without notice. Renesas grants you permission to use these resources only for development of an application that uses Renesas products. Other reproduction or use of these resources is strictly prohibited. No license is granted to any other Renesas intellectual property or to any third party intellectual property. Renesas disclaims responsibility for, and you will fully indemnify Renesas and its representatives against, any claims, damages, costs, losses, or liabilities arising out of your use of these resources. Renesas' products are provided only subject to Renesas' Terms and Conditions of Sale or other applicable terms agreed to in writing. No use of any Renesas resources expands or otherwise alters any applicable warranties or warranty disclaimers for these products.

(Rev.1.0 Mar 2020)

### Corporate Headquarters

TOYOSU FORESIA, 3-2-24 Toyosu,  
Koto-ku, Tokyo 135-0061, Japan  
[www.renesas.com](http://www.renesas.com)

### Contact Information

For further information on a product, technology, the most up-to-date version of a document, or your nearest sales office, please visit:  
[www.renesas.com/contact/](http://www.renesas.com/contact/)

### Trademarks

Renesas and the Renesas logo are trademarks of Renesas Electronics Corporation. All trademarks and registered trademarks are the property of their respective owners.

## X-ON Electronics

Largest Supplier of Electrical and Electronic Components

*Click to view similar products for [SRAM](#) category:*

*Click to view products by [Renesas](#) manufacturer:*

Other Similar products are found below :

[CY6116A-35DMB](#) [CY7C1049GN-10VXI](#) [GS8161Z36DD-200I](#) [GS88237CB-200I](#) [RMLV0408EGSB-4S2#AA0](#) [IDT70V5388S166BG](#)  
[IS64WV3216BLL-15CTLA3](#) [IS66WVE4M16ECLL-70BLI](#) [PCF8570P](#) [K6F2008V2E-LF70000](#) [K6T4008C1B-GB70](#) [CY7C1353S-100AXC](#)  
[AS6C8016-55BIN](#) [AS7C164A-15PCN](#) [515712X](#) [IDT71V67603S133BG](#) [IS62WV51216EBLL-45BLI](#) [IS63WV1288DBLL-10HLI](#)  
[IS66WVE2M16ECLL-70BLI](#) [IS66WVE4M16EALL-70BLI](#) [IS61WV102416DBLL-10TLI](#) [CY7C1381KV33-100AXC](#) [CY7C1381KVE33-](#)  
[133AXI](#) [8602501XA](#) [5962-3829425MUA](#) [5962-3829430MUA](#) [5962-8866201YA](#) [5962-8866204TA](#) [5962-9062007MXA](#) [5962-](#)  
[9161705MXA](#) [GS882Z18CD-150I](#) [8413202RA](#) [5962-8866208YA](#) [5962-8866203YA](#) [IS61WV102416DBLL-10BLI](#) [CY7C1380KV33-](#)  
[250AXC](#) [AS6C8016-55BINTR](#) [GS81284Z18B-250I](#) [AS7C34096B-10TIN](#) [GS84018CB-200I](#) [IS62WV25616EALL-55TLI](#)  
[IS61WV204816BLL-10TLI](#) [GS8128418B-167IV](#) [CY7C1460KV25-200BZXI](#) [CY7C1315KV18-333BZXC](#) [CY62157G30-45ZSXI](#)  
[71V016SA12YG](#) [RMLV0416EGBG-4S2#AC0](#) [CY62126EV18LL-70BVXI](#) [CY62128ELL-45SX](#)