

## GENERAL DESCRIPTION

The 87339I-11 is a low skew, high performance Differential-to-3.3V LVPECL Clock Generator/Divider. The 87339I-11 has one differential clock input pair. The CLK, nCLK pair can accept most standard differential input levels. The clock enable is internally synchronized to eliminate runt pulses on the outputs during asynchronous assertion/deassertion of the clock enable pin.

Guaranteed output and part-to-part skew characteristics make the 87339I-11 ideal for clock distribution applications demanding well defined performance and repeatability.

## FEATURES

- Dual ÷2, ÷4 differential 3.3V LVPECL outputs;  
Dual ÷4, ÷5, ÷6 differential 3.3V LVPECL outputs
- One differential CLK, nCLK input pair
- CLK, nCLK pair can accept the following differential input levels: LVDS, LVPECL, LVHSTL, SSTL, HCSL
- Maximum clock input frequency: 1GHz
- Translates any single ended input signal (LVCMOS, LVTTTL, GTL) to LVPECL levels with resistor bias on nCLK input
- Output skew: 35ps (maximum)
- Part-to-part skew: 385ps (maximum)
- Bank skew: Bank A - 20ps (maximum)  
Bank B - 20ps (maximum)
- Propagation delay: 2.1ns (maximum)
- LVPECL mode operating voltage supply range:  
 $V_{CC} = 3V$  to  $3.6V$ ,  $V_{EE} = 0V$
- Available in lead-free (RoHS 6) package

## BLOCK DIAGRAM

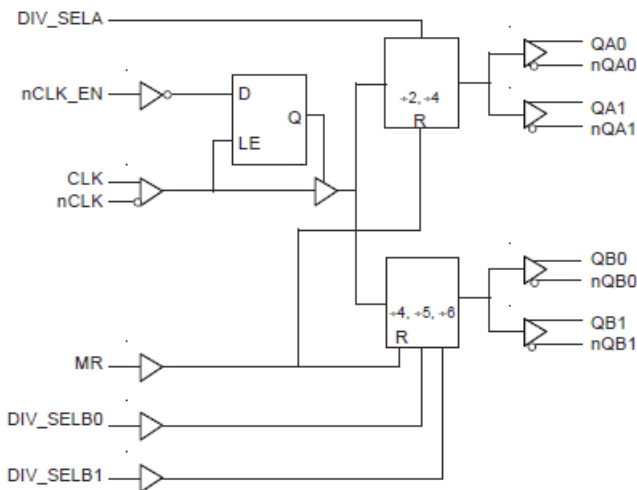

## PIN ASSIGNMENT

Vcc	1	20	Vcc
nCLK_EN	2	19	QA0
DIV_SELB0	3	18	nQA0
CLK	4	17	QA1
nCLK	5	16	nQA1
RESERVED	6	15	QB0
MR	7	14	nQB0
Vcc	8	13	QB1
DIV_SELB1	9	12	nQB1
DIV_SELA	10	11	Vee

### 87339I-11

#### 20-Lead TSSOP

6.50mm x 4.40mm x 0.92 package body

#### G Package

Top View

#### 20-Lead SOIC, 300MIL

7.5mm x 12.8mm x 2.25mm package body

#### M Package

Top View

**TABLE 1. PIN DESCRIPTIONS**

Number	Name	Type		Description
1, 8, 20	V <sub>CC</sub>	Power		Positive supply pins.
2	nCLK_EN	Input	Pulldown	Clock enable. LVCMOS / LVTTTL interface levels. See Table 3.
3	DIV_SELB0	Input	Pulldown	Selects divide value for Bank B outputs as described in Table 3. LVCMOS / LVTTTL interface levels.
4	CLK	Input	Pulldown	Non-inverting differential clock input.
5	nCLK	Input	Pullup	Inverting differential clock input.
6	RESERVED	Reserve		Reserve pin.
7	MR	Input	Pulldown	Active High Master Reset. When logic HIGH, the internal dividers are reset causing the true outputs Qx to go low and the inverted outputs nQx to go high. When logic LOW, the internal dividers and the outputs are enabled. LVCMOS / LVTTTL interface levels.
9	DIV_SELB1	Input	Pulldown	Selects divide value for Bank B outputs as described in Table 3. LVCMOS / LVTTTL interface levels.
10	DIV_SELA	Input	Pulldown	Selects divide value for Bank A outputs as described in Table 3. LVCMOS / LVTTTL interface levels.
11	V <sub>EE</sub>	Power		Negative supply pin.
12, 13	nQB1, QB1	Output		Differential output pair. LVPECL interface levels.
14, 15	nQB0, QB0	Output		Differential output pair. LVPECL interface levels.
16, 17	nQA1, QA1	Output		Differential output pair. LVPECL interface levels.
18, 19	nQA0, QA0	Output		Differential output pair. LVPECL interface levels.

NOTE: *Pullup* and *Pulldown* refer to internal input resistors. See Table 2, Pin Characteristics, for typical values.

**TABLE 2. PIN CHARACTERISTICS**

Symbol	Parameter	Test Conditions	Minimum	Typical	Maximum	Units
C <sub>IN</sub>	Input Capacitance			4		pF
R <sub>PULLUP</sub>	Input Pullup Resistor			51		kΩ
R <sub>PULLDOWN</sub>	Input Pulldown Resistor			51		kΩ

TABLE 3. CONTROL INPUT FUNCTION TABLE

Inputs					Outputs			
MR	nCLK_EN	DIV_SELA	DIV_SELB0	DIV_SELB1	QA0, QA1	nQA0, nQA1	QB0, QB1	nQB0, nQB1
1	X	X	X	X	LOW	HIGH	LOW	HIGH
0	1	X	X	X	Not Switching	Not Switching	Not Switching	Not Switching
0	0	0	0	0	÷2	÷2	÷4	÷4
0	0	0	0	1	÷2	÷2	÷5	÷5
0	0	0	1	0	÷2	÷2	÷6	÷6
0	0	0	1	1	÷2	÷2	÷5	÷5
0	0	1	0	0	÷4	÷4	÷4	÷4
0	0	1	0	1	÷4	÷4	÷5	÷5
0	0	1	1	0	÷4	÷4	÷6	÷6
0	0	1	1	1	÷4	÷4	÷5	÷5

NOTE: After nCLK\_EN switches, the clock outputs stop switching following a rising and falling input clock edge.

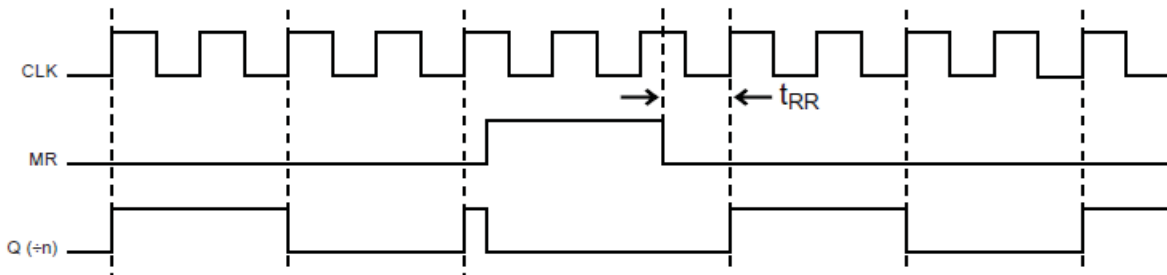

FIGURE 1A. MR TIMING DIAGRAM

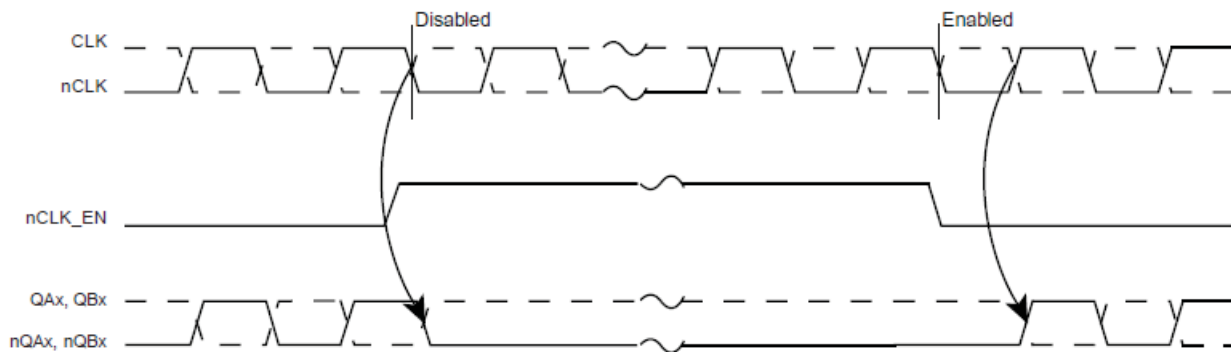

FIGURE 1B. nCLK\_EN TIMING DIAGRAM

**ABSOLUTE MAXIMUM RATINGS**

Supply Voltage, $V_{CC}$	4.6V
Inputs, $V_i$	-0.5V to $V_{CC} + 0.5V$
Outputs, $I_o$	
Continuous Current	50mA
Surge Current	100mA
Package Thermal Impedance, $\theta_{JA}$	
20 Lead TSSOP	73.2°C/W (0 lfpm)
20 Lead SOIC	46.2°C/W (0 lfpm)
Storage Temperature, $T_{STG}$	-65°C to 150°C

NOTE: Stresses beyond those listed under Absolute Maximum Ratings may cause permanent damage to the device. These ratings are stress specifications only. Functional operation of product at these conditions or any conditions beyond those listed in the *DC Characteristics* or *AC Characteristics* is not implied. Exposure to absolute maximum rating conditions for extended periods may affect product reliability.

**TABLE 4A. POWER SUPPLY DC CHARACTERISTICS,  $V_{CC} = 3.3V \pm 0.3V$ ,  $T_A = -40^\circ C$  TO  $85^\circ C$** 

Symbol	Parameter	Test Conditions	Minimum	Typical	Maximum	Units
$V_{CC}$	Positive Supply Voltage		3.0	3.3	3.6	V
$I_{EE}$	Power Supply Current				105	mA

**TABLE 4B. LVCMOS / LVTTTL DC CHARACTERISTICS,  $V_{CC} = 3.3V \pm 0.3V$ ,  $T_A = -40^\circ C$  TO  $85^\circ C$** 

Symbol	Parameter	Test Conditions	Minimum	Typical	Maximum	Units
$V_{IH}$	Input High Voltage		2		$V_{CC} + 0.3$	V
$V_{IL}$	Input Low Voltage		-0.3		0.8	V
$I_{IH}$	Input High Current	nCLK_EN, MR, DIV_SELA, DIV_SELBx $V_{IN} = V_{CC} = 3.6V$			150	$\mu A$
$I_{IL}$	Input Low Current	nCLK_EN, MR, DIV_SELA, DIV_SELBx $V_{IN} = 0V, V_{CC} = 3.6V$	-5			$\mu A$

**TABLE 4C. DIFFERENTIAL DC CHARACTERISTICS,  $V_{CC} = 3.3V \pm 0.3V$ ,  $T_A = -40^\circ C$  TO  $85^\circ C$** 

Symbol	Parameter	Test Conditions	Minimum	Typical	Maximum	Units
$I_{IH}$	Input High Current	nCLK	$V_{IN} = V_{CC} = 3.6V$		5	$\mu A$
		CLK	$V_{IN} = V_{CC} = 3.6V$		150	$\mu A$
$I_{IL}$	Input Low Current	nCLK	$V_{IN} = 0V, V_{CC} = 3.6V$	-150		$\mu A$
		CLK	$V_{IN} = 0V, V_{CC} = 3.6V$	-5		$\mu A$
$V_{PP}$	Peak-to-Peak Input Voltage		0.15		1.3	V
$V_{CMR}$	Common Mode Input Voltage; NOTE 1, 2		$V_{EE} + 0.5$		$V_{CC} - 0.85$	V

NOTE 1: For single ended applications, the maximum input voltage for CLK, nCLK is  $V_{CC} + 0.3V$ .

NOTE 2: Common mode voltage is defined as  $V_{IH}$ .

**TABLE 4D. LVPECL DC CHARACTERISTICS,  $V_{CC} = 3.3V \pm 0.3V$ ,  $T_A = -40^\circ C$  TO  $85^\circ C$** 

Symbol	Parameter	Test Conditions	Minimum	Typical	Maximum	Units
$V_{OH}$	Output High Voltage; NOTE 1		$V_{CC} - 1.4$		$V_{CC} - 0.9$	V
$V_{OL}$	Output Low Voltage; NOTE 1		$V_{CC} - 2.0$		$V_{CC} - 1.7$	V
$V_{SWING}$	Peak-to-Peak Output Voltage Swing		0.6		1.0	V

NOTE 1: Outputs terminated with  $50\Omega$  to  $V_{CC} - 2V$ .

**TABLE 5. AC CHARACTERISTICS,  $V_{CC} = 3.3V \pm 0.3V$ ,  $T_A = -40^\circ C$  TO  $85^\circ C$** 

Symbol	Parameter	Test Conditions	Minimum	Typical	Maximum	Units
$f_{CLK}$	Clock Input Frequency				1	GHz
$t_{PD}$	Propagation Delay; NOTE 1	CLK to Q (Diff)	1.6		2.1	ns
$t_{sk(o)}$	Output Skew; NOTE 2, 5			15	35	ps
$t_{sk(b)}$	Bank Skew; NOTE 3, 5	Bank A		10	20	ps
		Bank B		10	20	ps
$t_{sk(pp)}$	Part-to-Part Skew; NOTE 4, 5				385	ps
$t_S$	Setup Time	nCLK_EN to CLK	350			ps
$t_H$	Hold Time	CLK to nCLK_EN	100			ps
$t_{RR}$	Reset Recovery Time				400	ps
$t_{PW}$	Minimum Pulse Width	CLK	550			ps
$t_R / t_F$	Output Rise/Fall Time	20% to 80%	100		600	ps
odc	Output Duty Cycle		48		52	%

All data taken with outputs  $\div 4$ .

NOTE 1: Measured from the differential input crossing point to the differential output crossing point.

NOTE 2: Defined as skew between outputs at the same supply voltage and with equal load conditions. Measured at the output differential cross points

NOTE 3: Defined as skew within a bank of outputs and with equal load conditions.

NOTE 4: Defined as skew between outputs on different devices operating at the same supply voltages and with equal load conditions. Using the same type of inputs on each device, the outputs are measured at the differential cross points.

NOTE 5: This parameter is defined in accordance with JEDEC Standard 65.

# PARAMETER MEASUREMENT INFORMATION

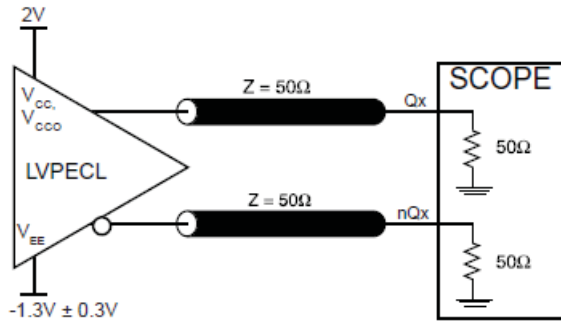

**3.3V OUTPUT LOAD AC TEST CIRCUIT**

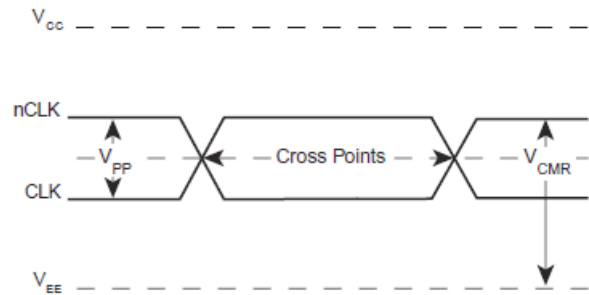

**DIFFERENTIAL INPUT LEVEL**

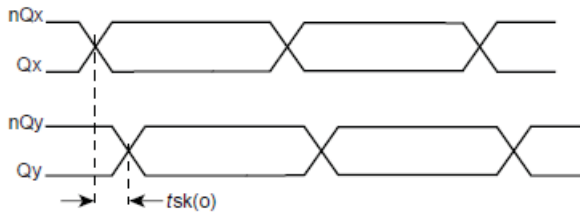

**OUTPUT SKEW**

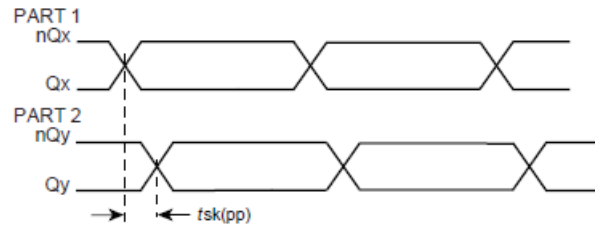

**PART-TO-PART SKEW**

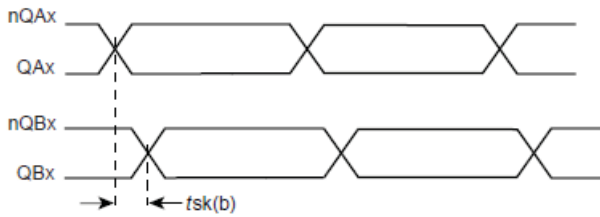

**BANK SKEW**

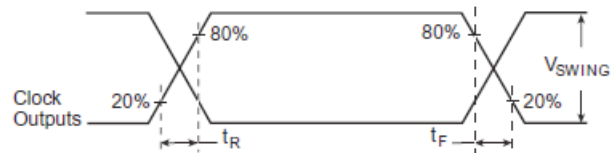

**OUTPUT RISE/FALL TIME**

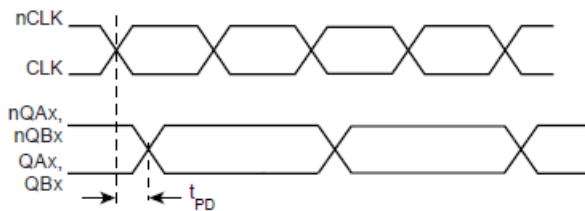

**PROPAGATION DELAY**

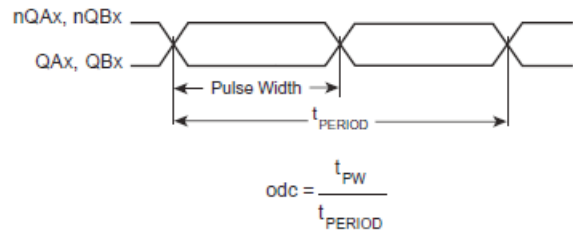

**OUTPUT DUTY CYCLE/PULSE WIDTH/PERIOD**

## APPLICATION INFORMATION

### WIRING THE DIFFERENTIAL INPUT TO ACCEPT SINGLE ENDED LEVELS

Figure 2 shows how the differential input can be wired to accept single ended levels. The reference voltage  $V_{REF} = V_{CC}/2$  is generated by the bias resistors R1, R2 and C1. This bias circuit should be located as close as possible to the input pin. The ratio

of R1 and R2 might need to be adjusted to position the  $V_{REF}$  in the center of the input voltage swing. For example, if the input clock swing is only 2.5V and  $V_{CC} = 3.3V$ ,  $V_{REF}$  should be 1.25V and  $R2/R1 = 0.609$ .

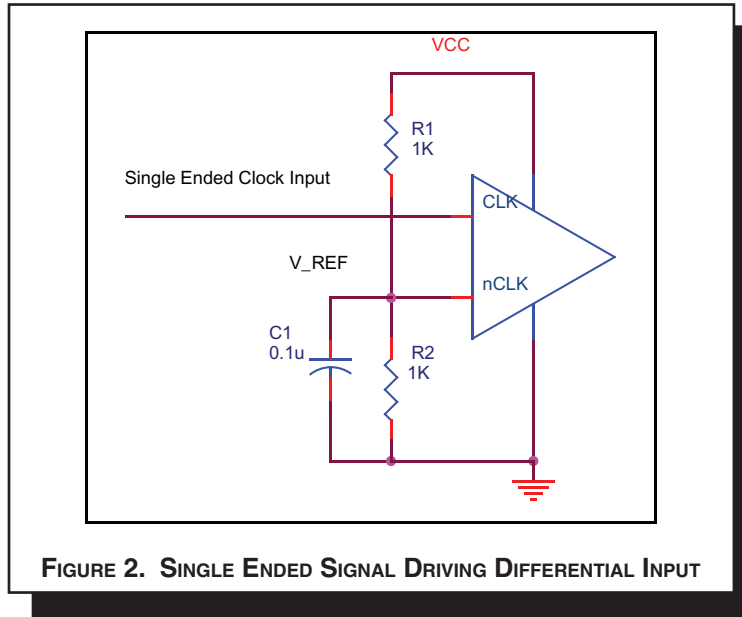

### TERMINATION FOR LVPECL OUTPUTS

The clock layout topology shown below is a typical termination for LVPECL outputs. The two different layouts mentioned are recommended only as guidelines.

FOUT and nFOUT are low impedance follower outputs that generate ECL/LVPECL compatible outputs. Therefore, terminating resistors (DC current path to ground) or current sources must be used for functionality. These outputs are designed to

drive 50Ω transmission lines. Matched impedance techniques should be used to maximize operating frequency and minimize signal distortion. Figures 3A and 3B show two different layouts which are recommended only as guidelines. Other suitable clock layouts may exist and it would be recommended that the board designers simulate to guarantee compatibility across all printed circuit and clock component process variations.

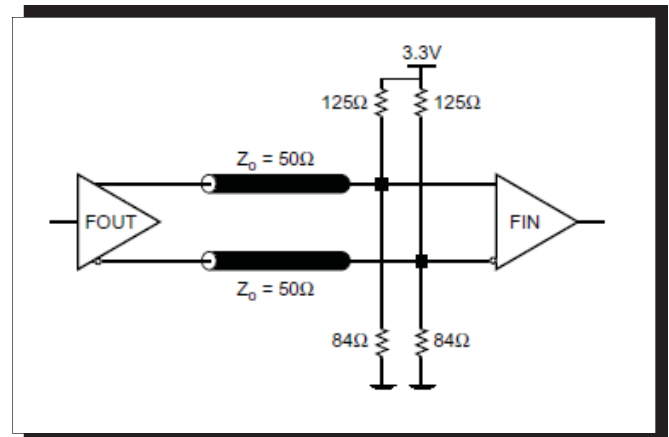
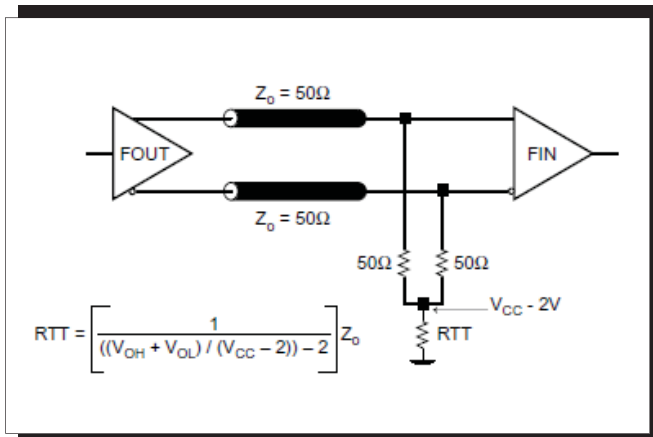

## DIFFERENTIAL CLOCK INPUT INTERFACE

The CLK/nCLK accepts LVDS, LVPECL, LVHSTL, SSTL, HCSL and other differential signals. Both  $V_{SWING}$  and  $V_{OH}$  must meet the  $V_{PP}$  and  $V_{CMR}$  input requirements. Figures 4A to 4E show interface examples for the CLK/nCLK input driven by the most common driver types. The input interfaces suggested here are

examples only. Please consult with the vendor of the driver component to confirm the driver termination requirements. For example in *Figure 4A*, the input termination applies for LVHSTL drivers. If you are using an LVHSTL driver from another vendor, use their termination recommendation.

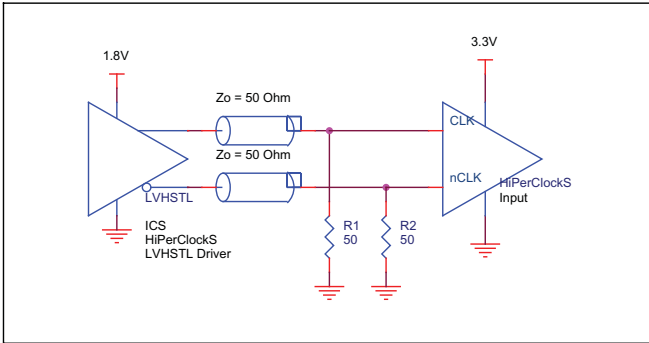

**FIGURE 4A. CLK/nCLK INPUT DRIVEN BY LVHSTL DRIVER**

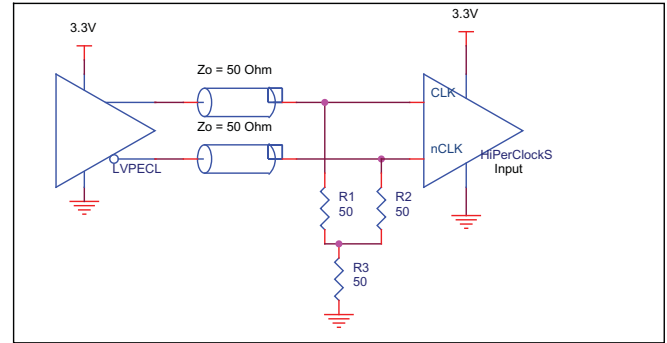

**FIGURE 4B. CLK/nCLK INPUT DRIVEN BY 3.3V LVPECL DRIVER**

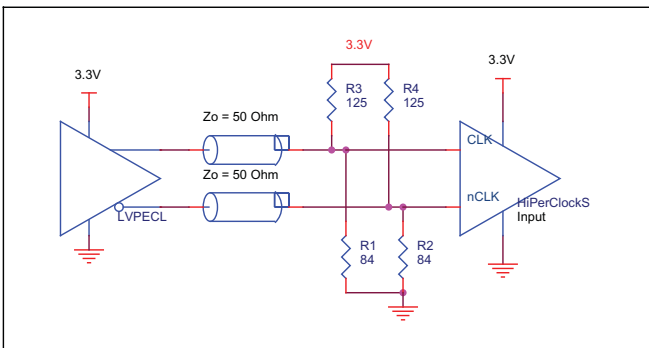

**FIGURE 4C. CLK/nCLK INPUT DRIVEN BY 3.3V LVPECL DRIVER**

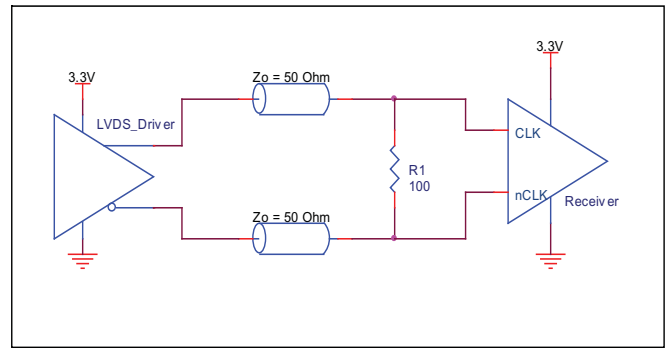

**FIGURE 4D. CLK/nCLK INPUT DRIVEN BY 3.3V LVDS DRIVER**

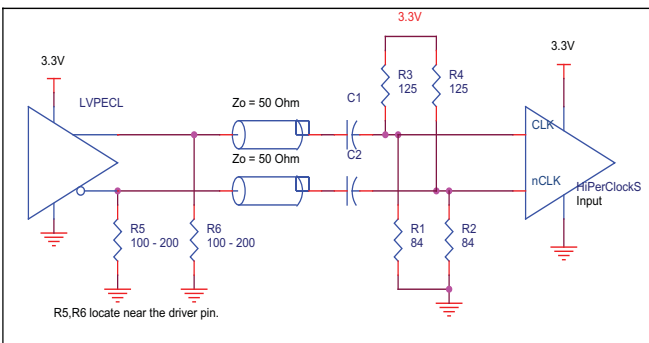

**FIGURE 4E. CLK/nCLK INPUT DRIVEN BY 3.3V LVPECL DRIVER WITH AC COUPLE**



## POWER CONSIDERATIONS

This section provides information on power dissipation and junction temperature for the 87339I-11. Equations and example calculations are also provided.

### 1. Power Dissipation.

The total power dissipation for the 87339I-11 is the sum of the core power plus the power dissipated in the load(s). The following is the power dissipation for  $V_{CC} = 3.3V + 0.3V = 3.6V$ , which gives worst case results.

**NOTE:** Please refer to Section 3 for details on calculating power dissipated in the load.

- Power (core)<sub>MAX</sub> =  $V_{CC\_MAX} * I_{CC\_MAX} = 3.6V * 105mA = 378mW$
- Power (outputs)<sub>MAX</sub> = **30mW/Loaded Output pair**  
If all outputs are loaded, the total power is  $4 * 30mW = 120mW$

**Total Power**<sub>MAX</sub> (3.6V, with all outputs switching) =  $378mW + 120mW = 498mW$

### 2. Junction Temperature.

Junction temperature, T<sub>j</sub>, is the temperature at the junction of the bond wire and bond pad and directly affects the reliability of the device. The maximum recommended junction temperature for the devices is 125°C.

The equation for T<sub>j</sub> is as follows:  $T_j = \theta_{JA} * Pd\_total + T_A$

T<sub>j</sub> = Junction Temperature

$\theta_{JA}$  = Junction-to-Ambient Thermal Resistance

Pd<sub>total</sub> = Total Device Power Dissipation (example calculation is in section 1 above)

T<sub>A</sub> = Ambient Temperature

In order to calculate junction temperature, the appropriate junction-to-ambient thermal resistance  $\theta_{JA}$  must be used. Assuming a moderate air flow of 200 linear feet per minute and a multi-layer board, the appropriate value is 66.6°C/W per Table 6A below. Therefore, T<sub>j</sub> for an ambient temperature of 85°C with all outputs switching is:

$85^\circ C + 0.498W * 66.6^\circ C/W = 118.1^\circ C$ . This is below the limit of 125°C.

This calculation is only an example. T<sub>j</sub> will obviously vary depending on the number of loaded outputs, supply voltage, air flow, and the type of board (single layer or multi-layer).

**Table 6A. Thermal Resistance  $\theta_{JA}$  for 20-pin TSSOP, Forced Convection**

	$\theta_{JA}$ by Velocity (Linear Feet per Minute)		
	0	200	500
Single-Layer PCB, JEDEC Standard Test Boards	114.5°C/W	98.0°C/W	88.0°C/W
Multi-Layer PCB, JEDEC Standard Test Boards	73.2°C/W	66.6°C/W	63.5°C/W

**NOTE:** Most modern PCB designs use multi-layered boards. The data in the second row pertains to most designs.

**Table 6B. Thermal Resistance  $\theta_{JA}$  for 20-pin SOIC, Forced Convection**

	$\theta_{JA}$ by Velocity (Linear Feet per Minute)		
	0	200	500
Single-Layer PCB, JEDEC Standard Test Boards	83.2°C/W	65.7°C/W	57.5°C/W
Multi-Layer PCB, JEDEC Standard Test Boards	46.2°C/W	39.7°C/W	36.8°C/W

**NOTE:** Most modern PCB designs use multi-layered boards. The data in the second row pertains to most designs.

3. Calculations and Equations.

LVPECL output driver circuit and termination are shown in Figure 5.

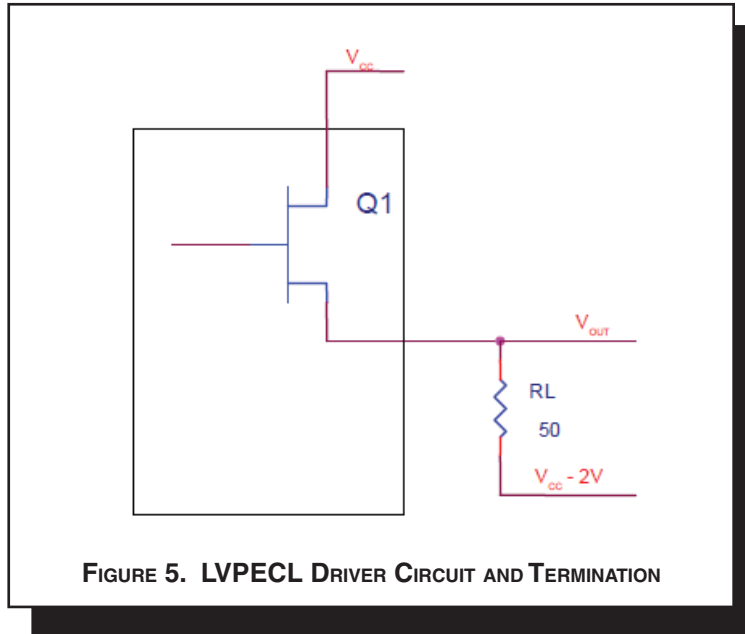

To calculate worst case power dissipation into the load, use the following equations which assume a 50Ω load, and a termination voltage of  $V_{CC} - 2V$ .

- For logic high,  $V_{OUT} = V_{OH\_MAX} = V_{CC\_MAX} - 0.9V$   
 $(V_{CC\_MAX} - V_{OH\_MAX}) = 0.9V$
- For logic low,  $V_{OUT} = V_{OL\_MAX} = V_{CC\_MAX} - 1.7V$   
 $(V_{CC\_MAX} - V_{OL\_MAX}) = 1.7V$

$Pd\_H$  is power dissipation when the output drives high.  
 $Pd\_L$  is the power dissipation when the output drives low.

$$Pd\_H = [(V_{OH\_MAX} - (V_{CC\_MAX} - 2V))/R_L] * (V_{CC\_MAX} - V_{OH\_MAX}) = [(2V - (V_{CC\_MAX} - V_{OH\_MAX}))/R_L] * (V_{CC\_MAX} - V_{OH\_MAX}) = [(2V - 0.9V)/50\Omega] * 0.9V = \mathbf{19.8mW}$$

$$Pd\_L = [(V_{OL\_MAX} - (V_{CC\_MAX} - 2V))/R_L] * (V_{CC\_MAX} - V_{OL\_MAX}) = [(2V - (V_{CC\_MAX} - V_{OL\_MAX}))/R_L] * (V_{CC\_MAX} - V_{OL\_MAX}) = [(2V - 1.7V)/50\Omega] * 1.7V = \mathbf{10.2mW}$$

$$\text{Total Power Dissipation per output pair} = Pd\_H + Pd\_L = \mathbf{30mW}$$

## RELIABILITY INFORMATION

**TABLE 7A.  $\theta_{JA}$  VS. AIR FLOW TSSOP TABLE**

$\theta_{JA}$ by Velocity (Linear Feet per Minute)			
	0	200	500
Single-Layer PCB, JEDEC Standard Test Boards	114.5°C/W	98.0°C/W	88.0°C/W
Multi-Layer PCB, JEDEC Standard Test Boards	73.2°C/W	66.6°C/W	63.5°C/W

**NOTE:** Most modern PCB designs use multi-layered boards. The data in the second row pertains to most designs.

**TABLE 7B.  $\theta_{JA}$  VS. AIR FLOW SOIC TABLE**

$\theta_{JA}$ by Velocity (Linear Feet per Minute)			
	0	200	500
Single-Layer PCB, JEDEC Standard Test Boards	83.2°C/W	65.7°C/W	57.5°C/W
Multi-Layer PCB, JEDEC Standard Test Boards	46.2°C/W	39.7°C/W	36.8°C/W

**NOTE:** Most modern PCB designs use multi-layered boards. The data in the second row pertains to most designs.

**TRANSISTOR COUNT**

The transistor count for 87339I-11 is: 1745

Compatible with MC10EP139, MC100EP139

PACKAGE OUTLINE - G SUFFIX FOR 20 LEAD TSSOP

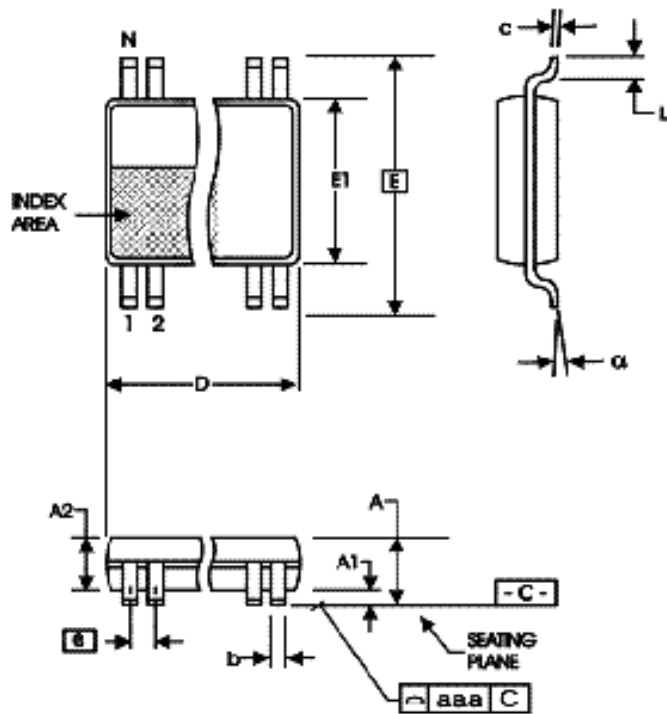

PACKAGE OUTLINE - M SUFFIX FOR 20 LEAD SOIC

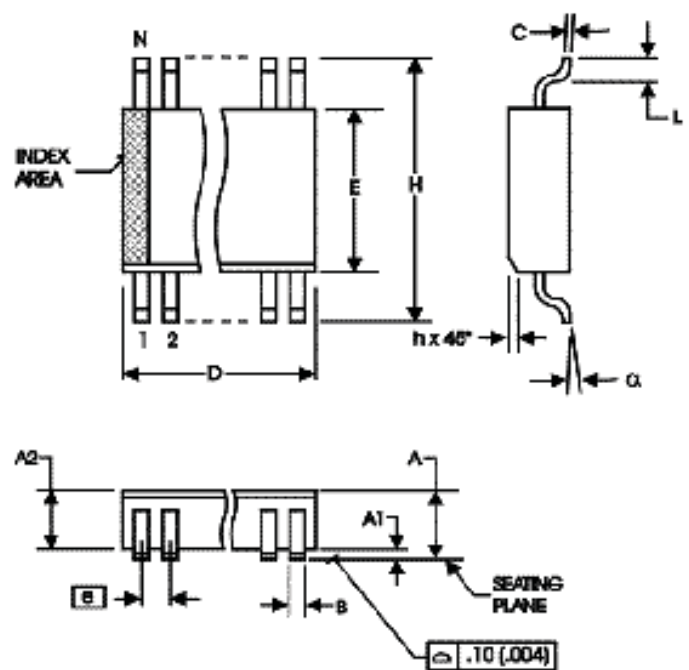

TABLE 8A. PACKAGE DIMENSIONS

SYMBOL	Millimeters	
	MIN	MAX
N	20	
A	--	1.20
A1	0.05	0.15
A2	0.80	1.05
b	0.19	0.30
c	0.09	0.20
D	6.40	6.60
E	6.40 BASIC	
E1	4.30	4.50
e	0.65 BASIC	
L	0.45	0.75
$\alpha$	0°	8°
aaa	--	0.10

Reference Document: JEDEC Publication 95, MO-153

TABLE 8B. PACKAGE DIMENSIONS

SYMBOL	Millimeters	
	Minimum	Maximum
N	20	
A	--	2.65
A1	0.10	--
A2	2.05	2.55
B	0.33	0.51
C	0.18	0.32
D	12.60	13.00
E	7.40	7.60
e	1.27 BASIC	
H	10.00	10.65
h	0.25	0.75
L	0.40	1.27
$\alpha$	0°	8°

Reference Document: JEDEC Publication 95, MS-013, MO-119

**TABLE 9. ORDERING INFORMATION**

Part/Order Number	Marking	Package	Shipping Packaging	Temperature
87339AGI-11LF	ICS7339AI11L	20 lead "Lead Free" TSSOP	Tube	-40°C to +85°C
87339AGI-11LFT	ICS7339AI11L	20 lead "Lead Free" TSSOP	Tape and Reel	-40°C to +85°C
87339AMI-11LF	ICS7339AI11L	20 lead "Lead Free" SOIC	Tube	-40°C to +85°C
87339AMI-11LFT	ICS7339AI11L	20 lead "Lead Free" SOIC	Tape and Reel	-40°C to +85°C

REVISION HISTORY SHEET				
Rev	Table	Page	Description of Change	Date
A	T1	1	Pin Assignment - changed pin 6, "nc" to "reserved".	3/10/05
		2	Pin Description table - corrected pin 6 to read reserved to coordinate with Pin Assignment.	
A	T9	1 13	Features section - corrected Output skew and Part-to-Part skew bullets. Ordering Information table - added Lead-Free note.	4/12/05
A	T9	13	Ordering Information table - added Lead-Free markings	12/19/07
B	T9	13	Updated datasheet's header/footer with IDT from ICS.	8/2/10
		15	Removed ICS prefix from Part/Order Number column. Added Contact Page.	
B	T9	1	Remove ICS from part numbers where needed.	1/25/16
		13	Features section - removed reference to leaded package. Ordering Information - remove quantity from tape and reel. Deleted LF note below the table. Updated header and footer.	



## IMPORTANT NOTICE AND DISCLAIMER

RENESAS ELECTRONICS CORPORATION AND ITS SUBSIDIARIES (“RENESAS”) PROVIDES TECHNICAL SPECIFICATIONS AND RELIABILITY DATA (INCLUDING DATASHEETS), DESIGN RESOURCES (INCLUDING REFERENCE DESIGNS), APPLICATION OR OTHER DESIGN ADVICE, WEB TOOLS, SAFETY INFORMATION, AND OTHER RESOURCES “AS IS” AND WITH ALL FAULTS, AND DISCLAIMS ALL WARRANTIES, EXPRESS OR IMPLIED, INCLUDING, WITHOUT LIMITATION, ANY IMPLIED WARRANTIES OF MERCHANTABILITY, FITNESS FOR A PARTICULAR PURPOSE, OR NON-INFRINGEMENT OF THIRD PARTY INTELLECTUAL PROPERTY RIGHTS.

These resources are intended for developers skilled in the art designing with Renesas products. You are solely responsible for (1) selecting the appropriate products for your application, (2) designing, validating, and testing your application, and (3) ensuring your application meets applicable standards, and any other safety, security, or other requirements. These resources are subject to change without notice. Renesas grants you permission to use these resources only for development of an application that uses Renesas products. Other reproduction or use of these resources is strictly prohibited. No license is granted to any other Renesas intellectual property or to any third party intellectual property. Renesas disclaims responsibility for, and you will fully indemnify Renesas and its representatives against, any claims, damages, costs, losses, or liabilities arising out of your use of these resources. Renesas' products are provided only subject to Renesas' Terms and Conditions of Sale or other applicable terms agreed to in writing. No use of any Renesas resources expands or otherwise alters any applicable warranties or warranty disclaimers for these products.

(Rev.1.0 Mar 2020)

### Corporate Headquarters

TOYOSU FORESIA, 3-2-24 Toyosu,  
Koto-ku, Tokyo 135-0061, Japan  
[www.renesas.com](http://www.renesas.com)

### Contact Information

For further information on a product, technology, the most up-to-date version of a document, or your nearest sales office, please visit:  
[www.renesas.com/contact/](http://www.renesas.com/contact/)

### Trademarks

Renesas and the Renesas logo are trademarks of Renesas Electronics Corporation. All trademarks and registered trademarks are the property of their respective owners.



## X-ON Electronics

Largest Supplier of Electrical and Electronic Components

*Click to view similar products for [Clock Generators & Support Products](#) category:*

*Click to view products by [Renesas](#) manufacturer:*

Other Similar products are found below :

[CV183-2TPAG](#) [950810CGLF](#) [9DBV0741AKILF](#) [9VRS4420DKLF](#) [CY25404ZXI226](#) [CY25422SXI-004](#) [MPC9893AE](#) [NB3H5150-01MNTXG](#) [PL602-20-K52TC](#) [ICS557GI-03LF](#) [PI6LC48P0101LIE](#) [82P33814ANLG](#) [840021AGLF](#) [ZL30244LFG7](#) [PI6LC48C21LE](#) [ZL30245LFG7](#) [PI6LC48P0405LIE](#) [PI6LC48P03LE](#) [MAX24505EXG+](#) [ZL30163GDG2](#) [5L1503L-000NVGI8](#) [ZL30673LFG7](#) [MAX24188ETK2](#) [ZL30152GGG2](#) [5L1503-000NVGI8](#) [PI6C557-01BZHIEX](#) [PI6LC48C21LIE](#) [CY2542QC002](#) [5P35023-106NLGI](#) [5X1503L-000NLGI8](#) [ZL30121GGG2V2](#) [ZL30282LDG1](#) [ZL30102QDG1](#) [ZL30159GGG2](#) [DS1070K](#) [ZL30145GGG2](#) [ZL30312GKG2](#) [MAX24405EXG2](#) [ZL30237GGG2](#) [SY100EL34LZG](#) [9FGV1002BQ506LTGI](#) [AD9518-4ABCPZ](#) [MX852BB0030](#) [PI6LC4840ZHE](#) [AD9516-0BCPZ-REEL7](#) [AD9574BCPZ-REEL7](#) [PL602-21TC-R](#) [ZL30105QDG1](#) [ZL30100QDG1](#) [ZL30142GGG2](#)