



Integrated Device Technology

The Analog and Digital Company™

8EBV89316 Installation Guide - Windows®

Prepare Hardware

1. Choose suitable power adapter from selection provided in the evaluation kit
2. Attach adapter to power supply and plug in to mains supply but do not plug into the board yet
3. Plug USB cable into computer but do not plug into board yet
4. Check jumper and DIP switch settings match the 8EBV89316 hardware configuration shown on the next page

8EBV89316 Hardware Configuration

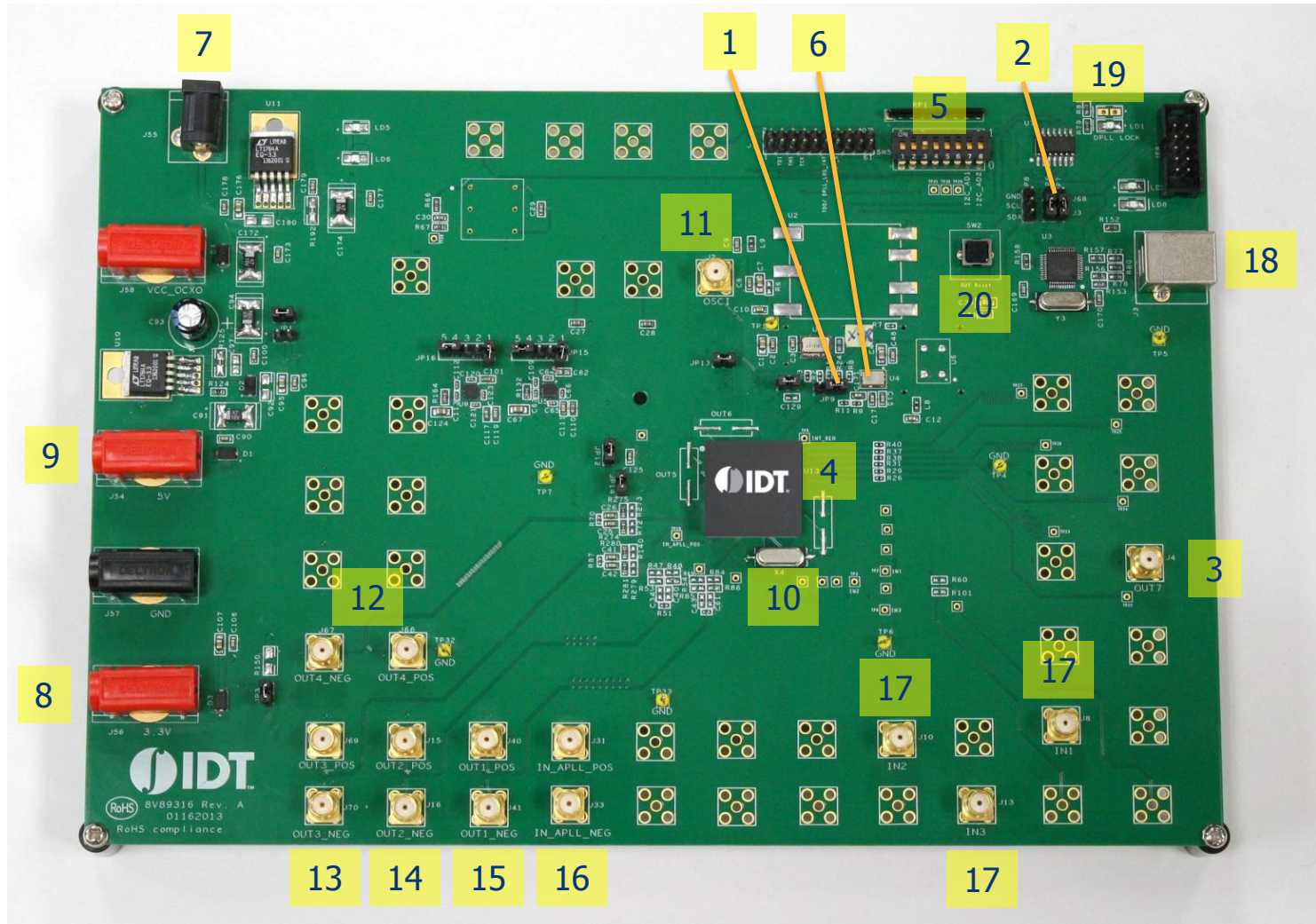

8EBV89316 Hardware Configuration

- [1] JP9 jumper. Leave at factory set position for normal operation (linking center and right pins)
- [2] JP6 and JP7 jumpers. Leave at factory set position for normal operation (linking center and lower pins)
- [3] LVCMOS Output clock
- [4] IDT8V89316 chip
- [5] Switch SW5: The function of this switch is described in Table 1
- [6] Crystal oscillator Master Clock
- [7] +5 V DC power supply
- [8] +3.3 V power supply for test purpose
- [9] +5 V power supply for test purpose
- [10] Crystal oscillator for APLL
- [11] OSCI: master clock input
- [12] Output clock 4 (differential)
- [13] Output clock 3 (differential)
- [14] Output clock 2 (differential)
- [15] Output clock 1 (differential)
- [16] Input clock to APLL (differential)
- [17] Input clock 1, 2 and 3
- [18] USB communication port
- [19] DPLL lock indicator
- [20] Reset button: Press to reset all devices on the board. Restart the management API following a reset to reconnect the host computer to the board.

Table 1: Switch SW5 Functions

Switch	Function	
SW5-1	Not used	
SW5-2	Not used	
SW5-3	Must be set on for normal operation	Off: "0" On: "1"
SW5-4	Not used	
SW5-5	Not used	
SW5-6	Not used	
SW5-7	I2C_AD1 Set off for normal operation	Off: "0" On: "1"
SW5-8	I2C_AD2 Set off for normal operation	Off: "0" On: "1"

Note: Evaluation board GUI expects a fixed I2C address of 0x51. SW5-7 and SW5-8 should be set to 0 (off) for normal operation.

Install 8EBV89316 Software

1. Unzip the 8EBV89316 and 8EBV89317 combined GUI zip file and copy contents to a new folder on the Windows®-based computer (for example C:\Users\...\Desktop\PLL_GUI_Files)
2. If Java® is not already installed on the computer, install it from <http://www.oracle.com/technetwork/java/javase/downloads/jre8-downloads-2133155.html>
3. If Visual Studio® C++ Redistributable Package is not already installed on the computer, install it from <http://www.microsoft.com/en-ca/download/details.aspx?id=5555>
4. Click on <http://www.ftdichip.com/Drivers/D2XX.htm>
5. Click on “set executable” in table, this launches the following executable:
<http://www.ftdichip.com/Drivers/CDM/CDM%20v2.10.00%20WHQL%20Certified.exe>
6. For manual installation using Windows® device manager, follow procedure in [1] on the “Useful Information and Links” page at the end of this guide

Start Hardware and Connect to Management API

1. Plug USB cable into board
 - Red LED LD8 lights next to USB socket on board
 - Windows® drivers load for new hardware
2. Plug power supply into socket marked J55
 - Red LEDs LD5 and LD6 light
3. Run winplmgmt.exe from the folder created in step 1 – either from a DOS window or by double-clicking the file in Explorer
4. A DOS window appears as shown on the next page. Leave this window open. CTRL-C stops the process and returns to the command prompt.
5. To reconnect the board to the Management API after a manual board reset, run winplmgmt.exe again as in step 3 above.

Connect to Management API

```
C:\Users\jb\Desktop\PLL GUI Files\winpllmgmt.exe
IDTSample_InitDriverI2c: numberOfXtal: 1
IDTSample_InitDriverI2c: xtal ID: 1
IDTSample_InitDriverI2c: xtal frequency: 0
Appl.c:318:IDTAppl_ValidateXtalInput: xtalList: 00A3ABC8, numberOfXtal: 1
IDTGeneral_InitDriver: numberOfXtal/1 i2cAddr/0x51
IDTGeneral_InitDriverCommon name/dev8089316
ftdi_i2c_static.c:ftdi_i2c_init:248: Number of available I2C channels = 1
    Flags=0x0
    Type=0x4
    ID=0x4036010
    LocId=0x2131
    SerialNumber=A
    Description=Dual RS232 A
    ftHandle=0x00000000
ftdi_i2c_static.c:ftdi_i2c_init:264: I2C_OpenChannel, handle=00CC2BB8, status=0
ftdi_i2c_static.c:ftdi_i2c_init:277: I2C_InitChannel return 0
IDTGeneral_InitDriver: xtal id: 1, xtal frequency: 0
IDTAppl_InitDriver name/apl12
XTAL 1 Freq/0
XTAL 2 Freq/3
ftdi_i2c_static.c:ftdi_i2c_init:248: Number of available I2C channels = 1
    Flags=0x1
    Type=0x4
    ID=0x4036010
    LocId=0x2131
    SerialNumber=A
    Description=Dual RS232 A
    ftHandle=0x00CC2BB8
ftdi_i2c_static.c:263:ftdi_i2c_init(): status(0x3) != FT_OK
IDTGeneral_InitDevice: dev/dev8089316
IDTGeneral_SetFullyUnprotectMode dev/dev8089316
IDTGeneral_InitDeviceCommon dev/dev8089316
IDTOutput_DisableAllIntOutput dev/dev8089316
ApplUtil.c:617:IDTAppl_XtalConfigured: APLL/apl12
apl1/apl12 apl1XtalId/0 apl1XtalFreq/0
IDTGeneral_GetDeviceID dev/dev8089316
Device ID = 3391
Attempting to bind server
bind returned success
TCP Management Server waiting for client on port 24585
```

GUI Start Screen

- Run PllGui.jar from the folder created in step 1 – either from a DOS window or by clicking the file in Explorer. The window below appears.



Useful information and links

- The computer is now connected to the Evaluation board and the GUI is ready for use. Details of the GUI operation are found in the “Ethernet PLL Configuration GUI User Manual” included with the GUI zip file
- FTDI chip Windows® 7 application note an-119:
http://www.ftdichip.com/Support/Documents/AppNotes/AN_119_FTDI_Drivers_Installation_Guide_for_Windows7.pdf
Note that USB 2.0 connection using USB 3.0 ports in Windows 7 is not currently supported
- USB view (for verifying the FTDI USB port location)
 - <http://www.ftdichip.com/Support/Utilities/usbview.zip>

*Windows and Visual Studio are registered trademarks of Microsoft Corporation in the United States and/or other countries.
Oracle and Java are registered trademarks of Oracle and/or its affiliates. Other names may be trademarks of their respective owners.*

USB View for Typical USB Tree

The screenshot displays the Windows USB View utility. The left pane shows a tree view of the USB system. Under 'My Computer', there are two Intel(R) 6 Series/C200 Series Chipset Family USB Enhanced Host Controller - 1C2D. The first controller has a RootHub [PIP 5&d64713a&1] with a Generic USB Hub [Loc111] and several other ports. The second controller has a RootHub [PIP 5&2742c7b&1] with a Generic USB Hub [Loc211] and several other ports. The right pane shows the details for the selected device, [Loc211] DeviceConnected: USB Composite Device. The details include a Device Descriptor with fields like bcdUSB, bDeviceClass, bDeviceSubClass, bDeviceProtocol, bMaxPacketSize0, idVendor, idProduct, bcdDevice, iManufacturer, iProduct, and iSerialNumber. It also shows ConnectionStatus, Current Config Value, Device Bus Speed, Device Address, and Open Pipes. Three Endpoint Descriptors are listed for IN and OUT endpoints with their respective addresses, transfer types, and packet sizes. Finally, the Configuration Descriptor is shown with wTotalLength, bNumInterfaces, and bConfigurationValue.

USB View

File Options Help

My Computer

- Intel(R) 6 Series/C200 Series Chipset Family USB Enhanced Host Controller - 1C2D
 - [PIP 5&d64713a&1] RootHub
 - [Loc111] [PIP Not Found] DeviceConnected: Generic USB Hub
 - [Loc111] NoDeviceConnected
 - [Loc112] NoDeviceConnected
 - [Loc113] DeviceConnected: USB Composite Device
 - [Loc114] DeviceConnected: Qualcomm Atheros AR3012 Bluetooth 4.0 + HS Adapter
 - [Loc115] NoDeviceConnected
 - [Loc116] NoDeviceConnected
 - [Loc12] NoDeviceConnected
- Intel(R) 6 Series/C200 Series Chipset Family USB Enhanced Host Controller - 1C26
 - [PIP 5&2742c7b&1] RootHub
 - [Loc211] [PIP 6&10ed9bf&0] DeviceConnected: Generic USB Hub
 - [Loc211] DeviceConnected: USB Composite Device
 - [Loc212] NoDeviceConnected
 - [Loc213] NoDeviceConnected
 - [Loc214] NoDeviceConnected
 - [Loc215] NoDeviceConnected
 - [Loc216] NoDeviceConnected
 - [Loc22] NoDeviceConnected

Devices Connected: 5 Hubs Connected: 2

Device Descriptor:

bcdUSB: 0x0200
bDeviceClass: 0x00
bDeviceSubClass: 0x00
bDeviceProtocol: 0x00
bMaxPacketSize0: 0x08 (8)
idVendor: 0x0403 (Future Technology Devices Inte:
idProduct: 0x6010
bcdDevice: 0x0500
iManufacturer: 0x01
0x0409: "FTDI"
iProduct: 0x02
0x0409: "Dual RS232"
0x0409: "Dual RS232"
0x0409: "Dual RS232"
iSerialNumber: 0x00
bNumConfigurations: 0x01

ConnectionStatus: DeviceConnected
Current Config Value: 0x01
Device Bus Speed: Full
Device Address: 0x02
Open Pipes: 4

Endpoint Descriptor:

bEndpointAddress: 0x81 IN
Transfer Type: Bulk
wMaxPacketSize: 0x0040 (64)
bInterval: 0x00

Endpoint Descriptor:

bEndpointAddress: 0x02 OUT
Transfer Type: Bulk
wMaxPacketSize: 0x0040 (64)
bInterval: 0x00

Endpoint Descriptor:

bEndpointAddress: 0x83 IN
Transfer Type: Bulk
wMaxPacketSize: 0x0040 (64)
bInterval: 0x00

Endpoint Descriptor:

bEndpointAddress: 0x04 OUT
Transfer Type: Bulk
wMaxPacketSize: 0x0040 (64)
bInterval: 0x00

Configuration Descriptor:

wTotalLength: 0x0037
bNumInterfaces: 0x02
bConfigurationValue: 0x01

Schematics

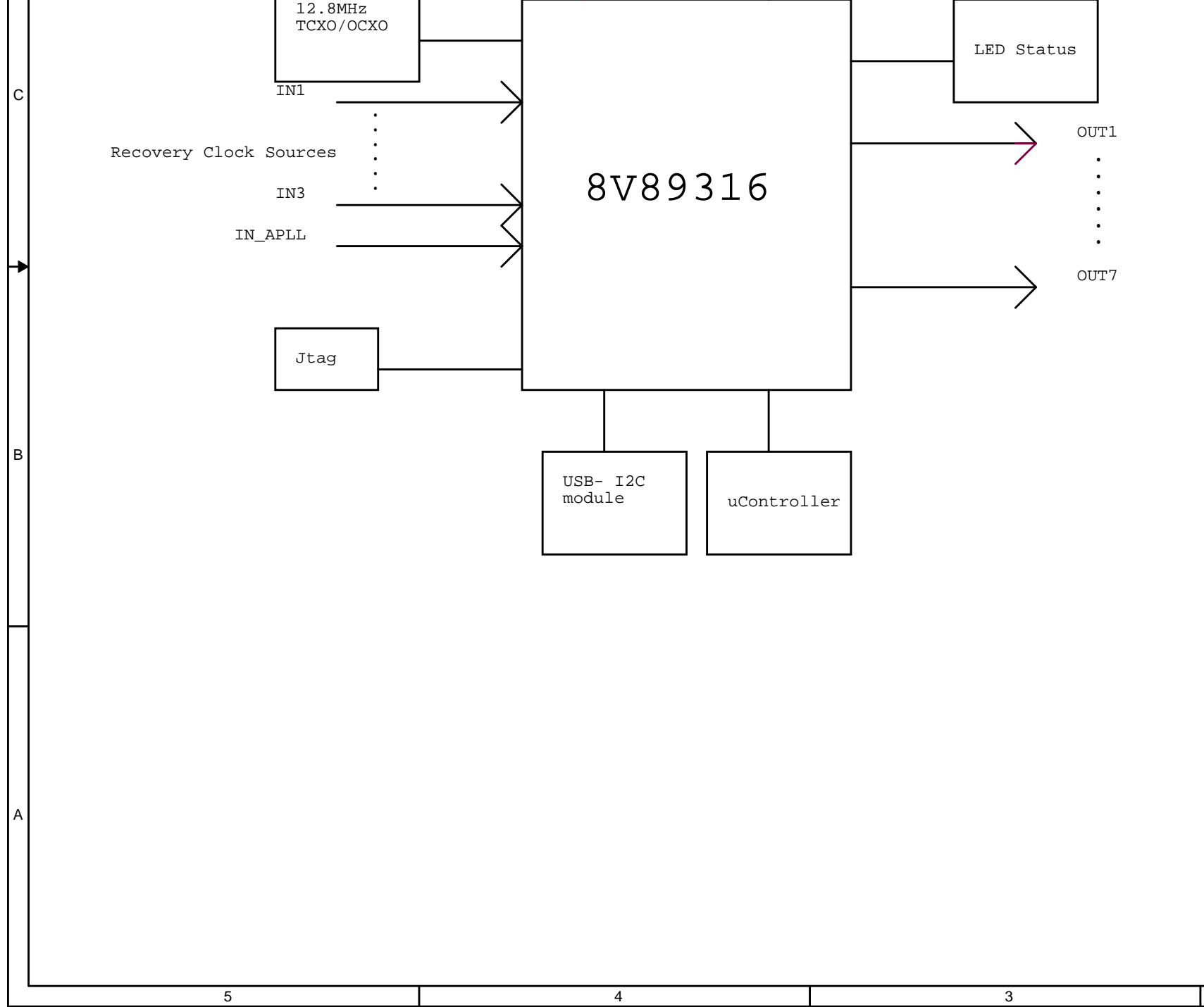

C

B

A

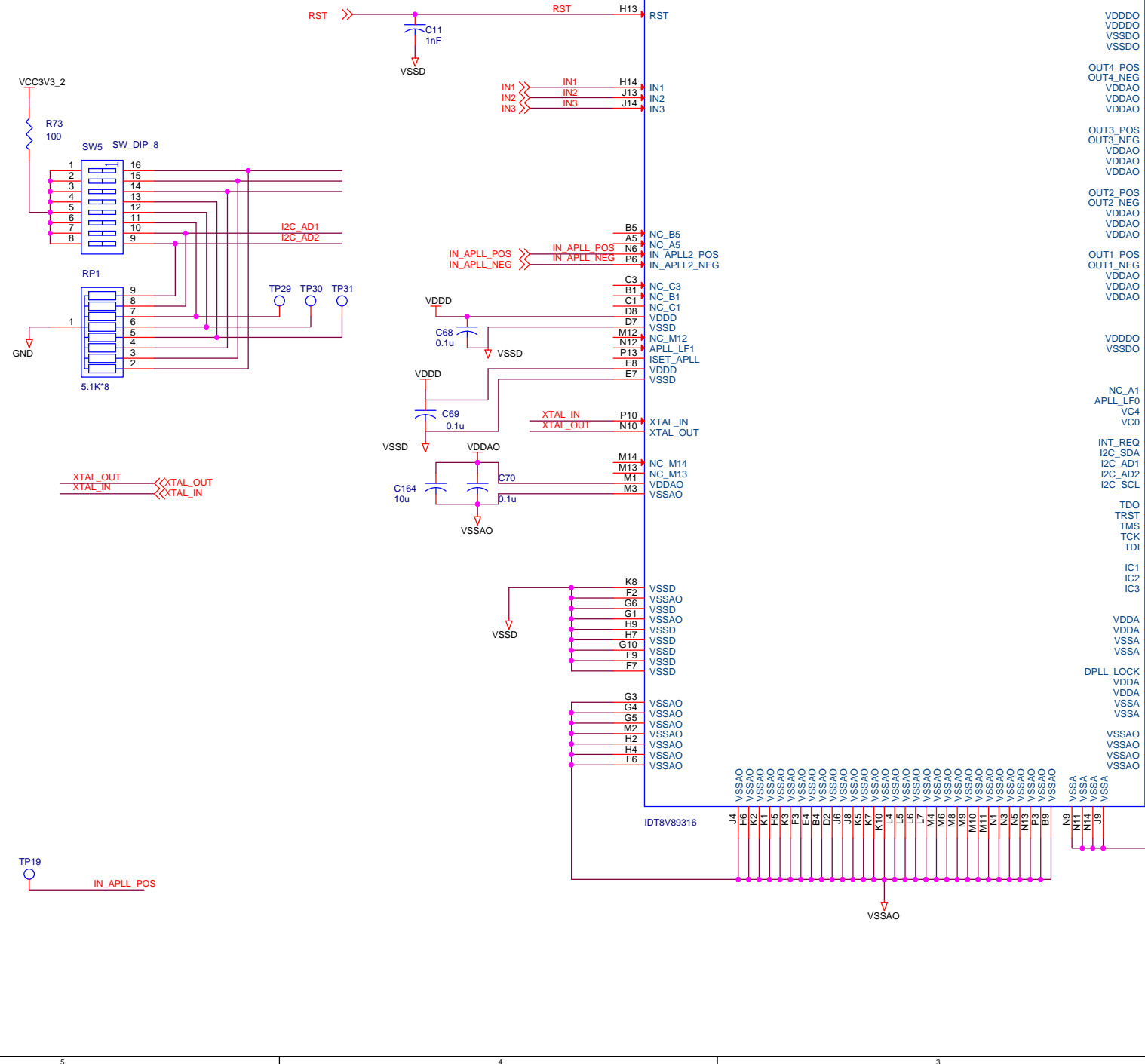

- OUT4_NEG
- VDDO
- VDDO
- VSSD
- VSSD
- OUT4_POS
- OUT4_NEG
- VDDAO
- VDDAO
- VDDAO
- OUT3_POS
- OUT3_NEG
- VDDAO
- VDDAO
- VDDAO
- OUT2_POS
- OUT2_NEG
- VDDAO
- VDDAO
- OUT1_POS
- OUT1_NEG
- VDDAO
- VDDAO
- VDDO
- VSSD
- NC_A1
- APLL_LF0
- VC4
- VC0
- INT_REQ
- I2C_SDA
- I2C_AD1
- I2C_AD2
- I2C_SCL
- TDO
- TRST
- TMS
- TCK
- TDI
- IC1
- IC2
- IC3
- VDDA
- VDDA
- VSSA
- VSSA
- DPLL_LOCK
- VDDA
- VDDA
- VSSA
- VSSA
- VSSAO
- VSSAO
- VSSAO
- VSSAO
- VSSAO
- VSSA
- VSSA
- VSSA
- VSSA

C

B

A

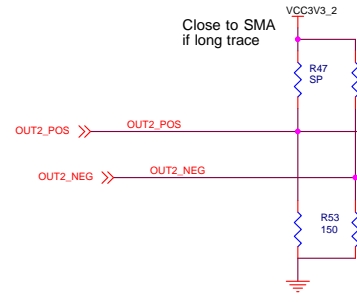
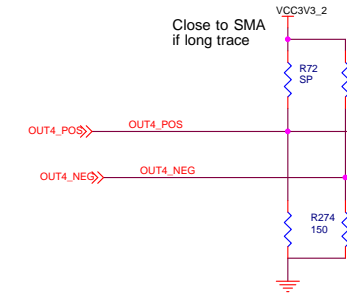
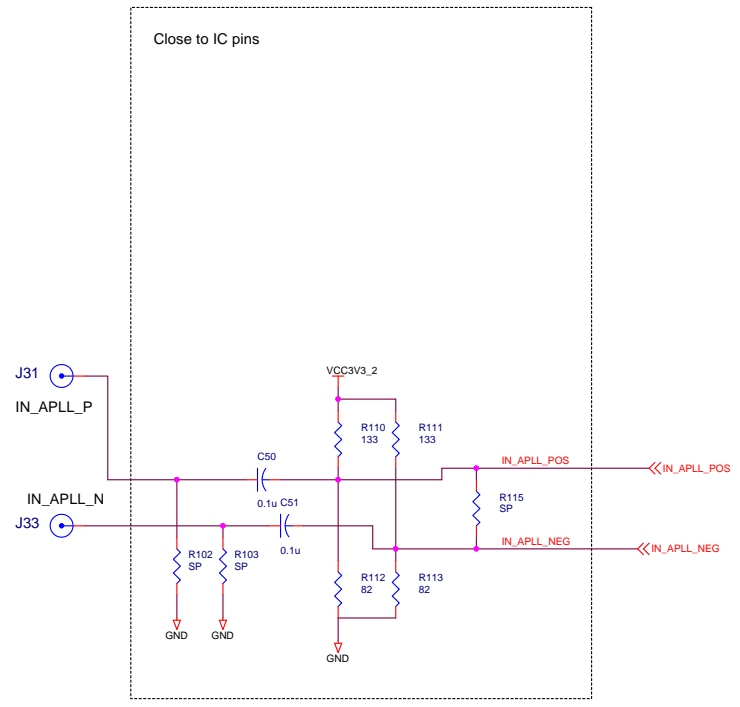

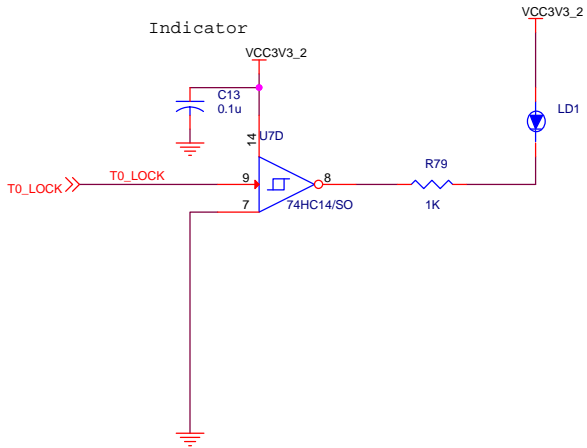
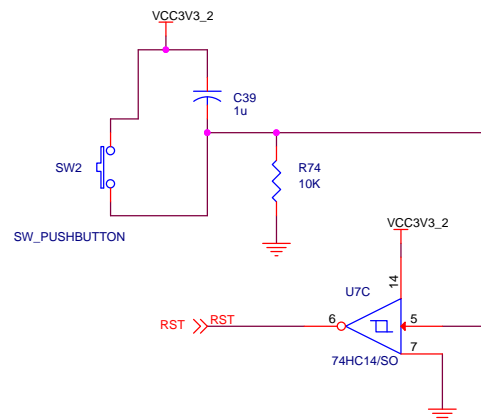
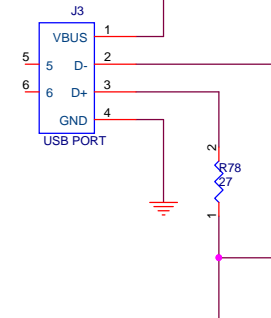
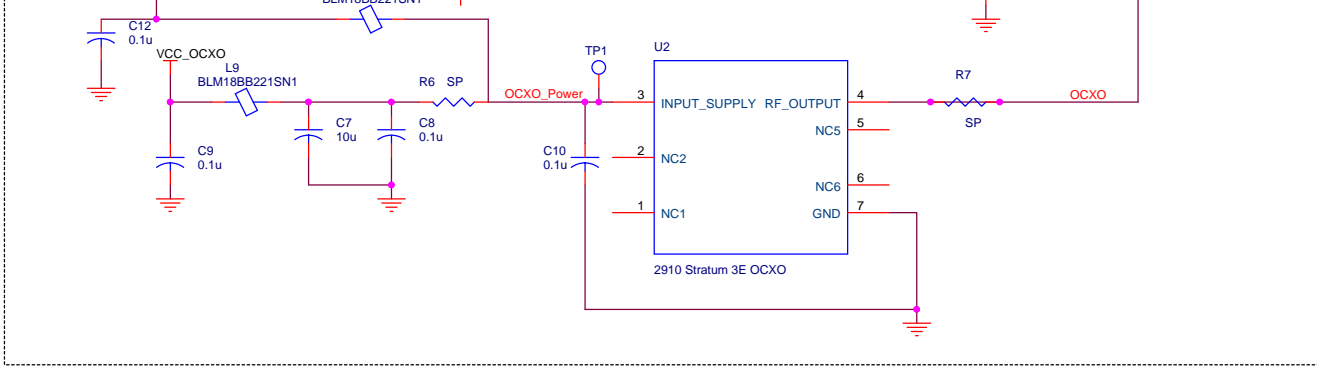

J57

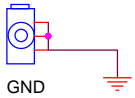

C



B

A

5

4

3

X-ON Electronics

Largest Supplier of Electrical and Electronic Components

Click to view similar products for [Clock & Timer Development Tools](#) category:

Click to view products by [Renesas](#) manufacturer:

Other Similar products are found below :

[AD9517-0A/PCBZ](#) [AD9522-4/PCBZ](#) [AD9520-5PCBZ](#) [AD9530/PCBZ](#) [AD9553/PCBZ](#) [ADCLK914PCBZ](#) [LMH2180SDEVAL](#) [DSC400-0333Q0032KE1-EVB](#) [TDGL013](#) [MAX2880EVKIT#](#) [MAX2750EVKIT](#) [MAX2752EVKIT](#) [ADCLK946PCBZ](#) [ADCLK946/PCBZ](#) [MAX2622EVKIT](#) [EKIT01-HMC1032LP6G](#) [Si5332-8IX-EVB](#) [Si5332-12IX-EVB](#) [RV-3029-C2-EVALUATION-BOARD-OPTION-B](#) [Si5332-6IX-EVB](#) [SKY72310-11-EVB](#) [EV1HMC8364LP6G](#) [RV-8263-C7-EVALUATION-BOARD](#) [EVK9FGV1002](#) [EVK9FGV1008](#) [EV1HMC6832ALP5L](#) [EVAL01-HMC830LP6GE](#) [EVAL01-HMC911LC4B](#) [EVAL01-HMC988LP3E](#) [TS3002DB](#) [125605-HMC702LP6CE](#) [LMX2487E-EVM](#) [MIKROE-2481](#) [2045](#) [EKIT01-HMC835LP6G](#) [EKIT01-HMC834LP6GE](#) [TS3006DB](#) [DSC-TIMEFLASH2-KIT1](#) [110227-HMC510LP5](#) [110227-HMC513LP5](#) [AD9515/PCBZ](#) [ADCLK948/PCBZ](#) [ADCLK954/PCBZ](#) [112261-HMC739LP4](#) [ADCLK925/PCBZ](#) [AD9522-0/PCBZ](#) [AD9520-4/PCBZ](#) [AC164147](#) [DFR0469](#) [LMK04133EVAL/NOPB](#)