

Description

The 8L30205 is a low skew, 1-to-5 LVCMOS / LVTTTL fanout buffer. The low impedance LVCMOS/LVTTTL outputs are designed to drive 50Ω series or parallel terminated transmission lines.

The 8L30205 is characterized at full 3.3V and 2.5V, mixed 3.3V/2.5V, 3.3V/1.8V, 3.3V/1.5V, 2.5V/1.8V and 2.5V/1.5V output operating supply modes. The input clock is selected with a differential clock input or a crystal input. The differential input can be wired to accept a single-ended input. The internal oscillator circuit is automatically disabled if the crystal input is not selected.

Features

- Five LVCMOS / LVTTTL outputs up to 200MHz
- Differential input pair can accept the following differential input levels: LVPECL, LVDS, HCSL
- Crystal oscillator interface
- Crystal input frequency range: 10MHz to 40MHz
- Additive RMS phase jitter: 30fs (typical)
- Synchronous output enable to avoid clock glitch
- Power supply modes:
Core / Output
3.3V / 3.3V
2.5V / 2.5V
3.3V / 2.5V
3.3V / 1.8V
3.3V / 1.5V
2.5V / 1.8V
2.5V / 1.5V
- -40°C to 85°C ambient operating temperature
- Supports case temperature up to 105°C
- Available in lead-free (RoHS 6) package

Block Diagram

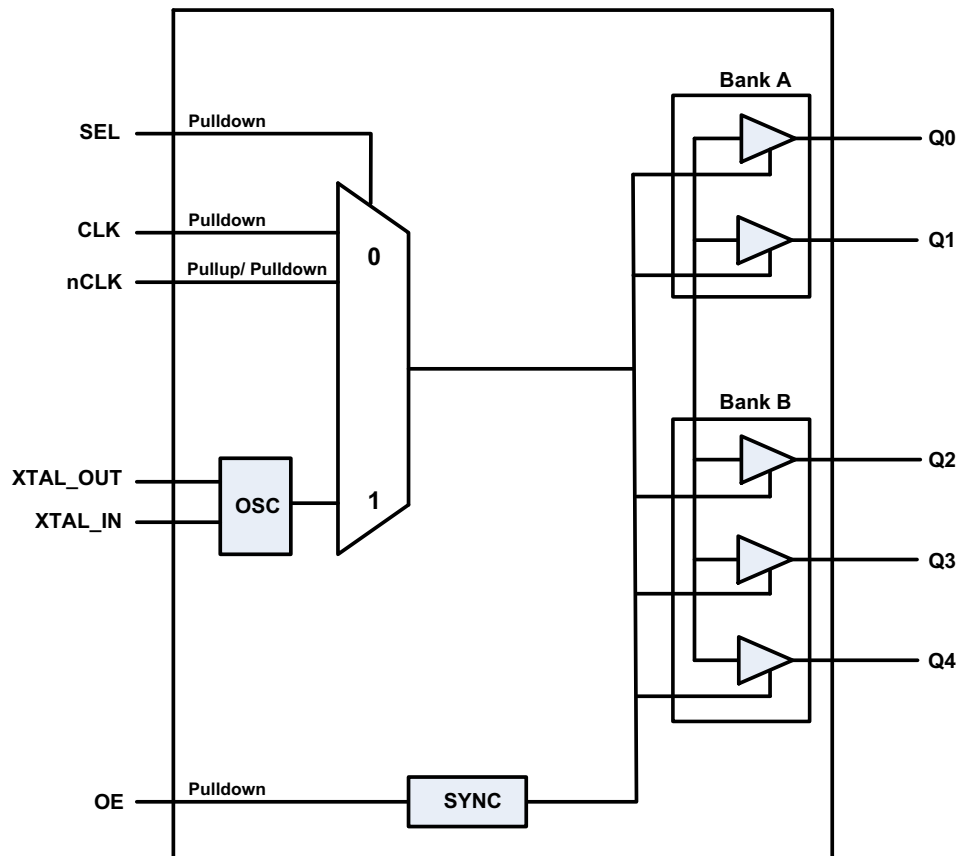

Pin Assignments

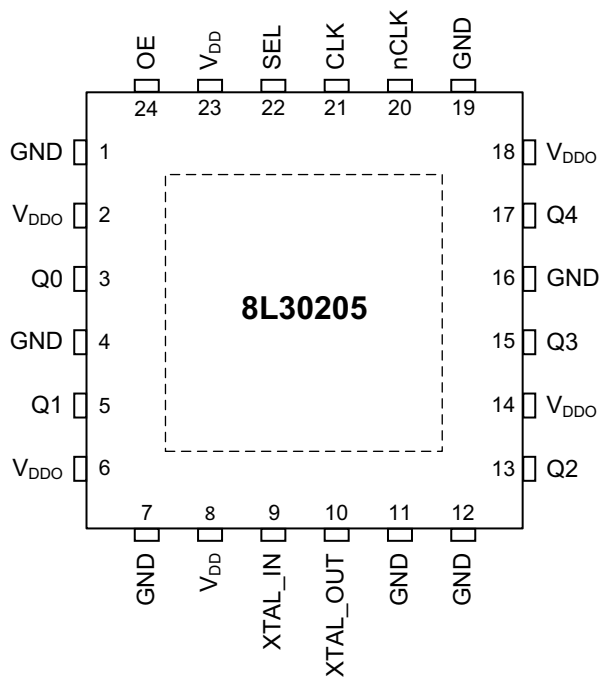

24-pin, 4mm x 4mm VFQFN Package

Pin Characteristics

Table 1. Pin Descriptions^[a]

Number	Name	Type	Description
1	GND	Power	Power supply ground.
2	V _{DDO}	Power	Output power supply pin for Bank A.
3	Q0	Output	Single-ended clock output. LVCMOS/LVTTL interface levels.
4	GND	Power	Power supply ground.
5	Q1	Output	Single-ended clock output. LVCMOS/LVTTL interface levels.
6	V _{DDO}	Power	Output power supply pin for Bank A.
7	GND	Power	Power supply ground.
8	V _{DD}	Power	Power supply pin.
9	XTAL_IN	Input	Crystal oscillator interface. XTAL_IN is the input.
10	XTAL_OUT	Input	Crystal oscillator interface. XTAL_OUT is the output.
11	GND	Power	Power supply ground.
12	GND	Power	Power supply ground.
13	Q2	Output	Single-ended clock output. LVCMOS/LVTTL interface levels.
14	V _{DDO}	Power	Output power supply pin for Bank B.
15	Q3	Output	Single-ended clock output. LVCMOS/LVTTL interface levels.

Table 1. Pin Descriptions^[a] (Cont.)

Number	Name	Type		Description
16	GND	Power		Power supply ground.
17	Q4	Output		Single-ended clock output. LVCMOS/LVTTL interface levels.
18	V _{DDO}	Power		Output power supply pin for Bank B.
19	GND	Power		Power supply ground.
20	nCLK	Input	Pullup/ Pulldown	Inverting differential clock. Internal resistor bias to V _{DD} /2.
21	CLK	Input	Pulldown	Non-inverting differential clock.
22	SEL	Input	Pulldown	Input clock selection. LVCMOS/LVTTL interface levels. See Table 3A.
23	V _{DD}	Power		Power supply pin.
24	OE	Input	Pulldown	Output enable. LVCMOS/LVTTL interface levels. See Table 3B.
ePad	Exposed Pad	Power		Must be connected to GND.

[a] *Pullup and Pulldown* refer to internal input resistors. See Table 2, *Pin Characteristics*, for typical values.

Table 2. Pin Characteristics

Symbol	Parameter		Test Conditions	Minimum	Typical	Maximum	Units
C _{IN}	Input Capacitance	SEL, OE, CLK, nCLK			2		pF
R _{PULLDOWN}	Input Pulldown Resistor				51		kΩ
R _{PULLUP}	Input Pullup Resistor				51		kΩ
C _{PD}	Power Dissipation Capacitance (per output)		V _{DDO} = 3.465V		11		pF
			V _{DDO} = 2.625V		9		pF
			V _{DDO} = 1.95V		8		pF
			V _{DDO} = 1.6V		8		pF
R _{OUT}	Output Impedance		V _{DDO} = 3.3V ± 5%		40		Ω
			V _{DDO} = 2.5V ± 5%		40		Ω
			V _{DDO} = 1.8V ± 0.15V		50		Ω
			V _{DDO} = 1.5V ± 0.1V		55		Ω

Function Tables

Table 3A. SEL Function Table

Control Input	Selected Input Clock
SEL	
0 (default)	CLK, nCLK
1	XTAL

Table 3B. OE Function Table

Control Input	Function
OE	Q[0:4]
0 (default)	High-Impedance
1	Enabled

Table 3C. Input/Output Operation Table^[a]

Input State			Output State
OE	SEL	CLK, nCLK	Q[0:4]
0	X	Do Not Care	High-Impedance
1	1	Do Not Care	Active
1	0	CLK = nCLK = Open	LOW
		CLK = HIGH, nCLK = LOW	HIGH
		CLK = LOW, nCLK = HIGH	LOW

[a] The device must have switching edge to obtain output states.

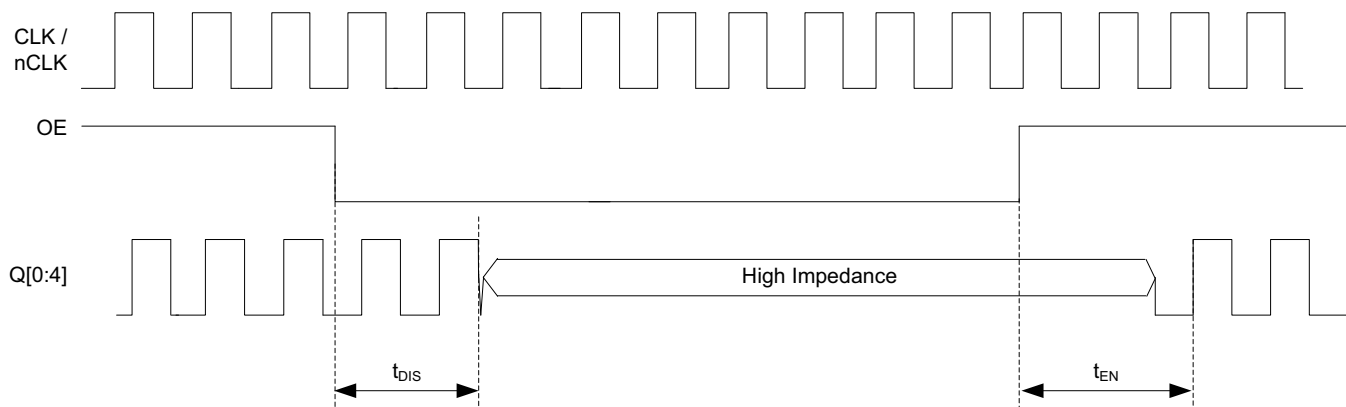

Figure 1. OE Timing Diagram

NOTE: The outputs will enable or disable 2 to 3 clock cycles after the transition on the OE input.

Absolute Maximum Ratings

NOTE: Stresses beyond those listed under *Absolute Maximum Ratings* may cause permanent damage to the device. These ratings are stress specifications only. Functional operation of product at these conditions or any conditions beyond those listed in the *DC Characteristics* or *AC Characteristics* is not implied. Exposure to absolute maximum rating conditions for extended periods may affect product reliability.

Item	Rating
Supply Voltage, V_{DD}	3.6V
Inputs, V_I CLK, nCLK XTAL_IN Other Inputs	3.6V 0V to 2V -0.5V to $V_{DD} + 0.5V$
Outputs, V_O	-0.5V to $V_{DDO} + 0.5V$
Junction Temperature, T_J	125°C
Storage Temperature, T_{STG}	-65°C to 150°C

DC Electrical Characteristics

Table 4A. Power Supply DC Characteristics, $V_{DD} = 3.3V \pm 5\%$, $V_{DDO} = 3.3V \pm 5\%$ or $2.5V \pm 5\%$ or $1.8V \pm 0.15V$ or $1.5V \pm 0.1V$, $T_A = -40^\circ\text{C}$ to 85°C

Symbol	Parameter	Test Conditions	Minimum	Typical	Maximum	Units
V_{DD}	Power Supply Voltage		3.135	3.3	3.465	V
V_{DDO}	Output Supply Voltage		3.135	3.3	3.465	V
			2.375	2.5	2.625	V
			1.65	1.8	1.95	V
			1.4	1.5	1.6	V
I_{DD}	Power Supply Current	No Clock Input, Outputs Unloaded			19	mA
I_{DDO}	Output Supply Current	OE = 1, $V_{DDO} = 3.3V \pm 5\%$, Outputs Unloaded			3	mA
		OE = 1, $V_{DDO} = 2.5V \pm 5\%$, Outputs Unloaded			2	mA
		OE = 1, $V_{DDO} = 1.8V \pm 0.15V$, Outputs Unloaded			2	mA
		OE = 1, $V_{DDO} = 1.5V \pm 0.1V$, Outputs Unloaded			2	mA

Table 4B. Power Supply DC Characteristics, $V_{DD} = 2.5V \pm 5\%$, $V_{DDO} = 2.5V \pm 5\%$ or $1.8V \pm 0.15V$ or $1.5V \pm 0.1V$, $T_A = -40^\circ\text{C}$ to 85°C

Symbol	Parameter	Test Conditions	Minimum	Typical	Maximum	Units
V_{DD}	Power Supply Voltage		2.375	2.5	2.625	V
V_{DDO}	Output Supply Current		2.375	2.5	2.625	V
			1.65	1.8	1.95	V
			1.4	1.5	1.6	V
I_{DD}	Power Supply Current	No Clock Input, Outputs Unloaded			19	mA
I_{DDO}	Output Supply Current	OE = 1, $V_{DDO} = 2.5V \pm 5\%$, Outputs Unloaded			2	mA
		OE = 1, $V_{DDO} = 1.8V \pm 0.15V$, Outputs Unloaded			2	mA
		OE = 1, $V_{DDO} = 1.5V \pm 0.1V$, Outputs Unloaded			2	mA

Table 4C. LVCMOS/LVTTL DC Characteristics, $T_A = -40^\circ\text{C}$ to 85°C

Symbol	Parameter	Test Conditions	Minimum	Typical	Maximum	Units
V_{IH}	Input High Voltage	$V_{DD} = 3.3V \pm 5\%$	2.2		$V_{DD} + 0.3$	V
		$V_{DD} = 2.5V \pm 5\%$	1.7		$V_{DD} + 0.3$	V
V_{IL}	Input Low Voltage	$V_{DD} = 3.3V \pm 5\%$	-0.3		0.8	V
		$V_{DD} = 2.5V \pm 5\%$	-0.3		0.7	V
I_{IH}	Input High Current	OE, SEL $V_{DD} = V_{IN} = 3.465V$			150	μA
I_{IL}	Input Low Current	OE, SEL $V_{DD} = 3.465V, V_{IN} = 0V$	-5			μA
V_{OH}	Output High Voltage	$I_{OH} = -100\mu\text{A}$	$V_{DDO} - 0.1$			V
V_{OL}	Output Low Voltage	$I_{OL} = 100\mu\text{A}$			0.1	V

Table 4D. Differential DC Characteristics, $V_{DD} = 3.3V \pm 5\%$ or $2.5V \pm 5\%$, $T_A = -40^\circ\text{C}$ to 85°C

Symbol	Parameter		Test Conditions	Minimum	Typical	Maximum	Units
I_{IH}	Input High Current	CLK, nCLK	$V_{DD} = V_{IN} = 3.465\text{V}$ or 2.625V			150	μA
I_{IL}	Input Low Current	CLK	$V_{DD} = 3.465\text{V}$ or 2.625V , $V_{IN} = 0\text{V}$	-5			μA
		nCLK	$V_{DD} = 3.465\text{V}$ or 2.625V , $V_{IN} = 0\text{V}$	-150			μA
V_{PP}	Peak-to-Peak Input Voltage ^[a]			0.15		1.5	V
V_{CMR}	Common Mode Input Voltage ^{[a], [b]}			0.5		$V_{DD} - 0.85$	V

[a] V_{IL} should not be less than -0.3V .

[b] Common mode voltage is defined at the crosspoint.

Table 5. Crystal Characteristics

Parameter	Test Conditions	Minimum	Typical	Maximum	Units
Mode of Oscillation		Fundamental			
Frequency		10		40	MHz
Equivalent Series Resistance (ESR)				50	Ω
Shunt Capacitance				7	pF
Load Capacitance			12	18	pF

AC Electrical Characteristics

Table 6. AC Characteristics, $V_{DD} = 3.3V \pm 5\%$, $V_{DDO} = 3.3V \pm 5\%$ or $2.5V \pm 5\%$ or $1.8V \pm 0.15V$ or $1.5V \pm 0.1V$, $T_A = -40^\circ C$ to $85^\circ C$ ^{[a], [b]}

Symbol	Parameter		Test Conditions	Minimum	Typical	Maximum	Units
f_{OUT}	Output Frequency	Using External Crystal		10		40	MHz
		Using External Clock Source				200	MHz
t_{PD}	Propagation Delay ^[c]		$V_{DDO} = 3.3V \pm 5\%$	1.3		2.7	ns
			$V_{DDO} = 2.5V \pm 5\%$	1.4		3.0	ns
			$V_{DDO} = 1.8V \pm 0.15V$	1.7		4.0	ns
			$V_{DDO} = 1.5V \pm 0.1V$	2.0		5.0	ns
$t_{sk(o)}$	Output Skew ^{[d], [e]}		Referenced to Q0			55	ps
$t_{sk(b)}$	Bank Skew ^{[e], [f]}	Bank A				25	ps
		Bank B				40	ps
t_{jit}	Buffer Additive Phase Jitter	Input Clock from CLK, nCLK	$f_{OUT} = 156.25MHz$, Integration Range: 12kHz - 20MHz		30		fs
$t_{jit}(\emptyset)$	RMS Phase Jitter	Input Clock from 25MHz Crystal	Integration Range: 12kHz - 5MHz		175		fs
t_R / t_F	Output Rise/Fall Time		$f_{OUT} = 156.25MHz$, 20% - 80%			700	ps
odc	Output Duty Cycle		50% Input Duty Cycle, $f_{OUT} = 156.25MHz$	45	50	55	%
MUX_ISOLATION	MUX Isolation ^[g]		156.25MHz		-84		dB
PSRR	Power Supply Rejection Ratio ^[h]				-70		dBc

[a] Typical values represent the part performance at $V_{DD} = V_{DDO} = 3.3V$, $T_A = 25^\circ C$ unless otherwise stated.

[b] Electrical parameters are guaranteed over the specified ambient operating temperature range, which is established when the device is mounted in a test socket with maintained transverse airflow greater than 500 lpm. The device will meet specifications after thermal equilibrium has been reached under these conditions.

[c] Measured from the differential input crossing point to $V_{DDO}/2$ of the output.

[d] Defined as skew between outputs at the same supply voltage and with equal load conditions. Measured at $V_{DDO}/2$.

[e] This parameter is defined in accordance with JEDEC Standard 65.

[f] Defined as skew within a bank with equal load conditions.

[g] These parameters are guaranteed by characterization. Not tested in production.

[h] 100kHz, 100mVpp Ripple Injected on $V_{DDO} = 2.5V$.

Applications Information

Recommendations for Unused Input and Output Pins

Inputs:

CLK/nCLK Inputs

For applications not requiring the use of the differential input, both CLK and nCLK can be left floating. Though not required, but for additional protection, a 1k Ω resistor can be tied from CLK to ground.

Crystal Inputs

For applications not requiring the use of the crystal oscillator input, both XTAL_IN and XTAL_OUT can be left floating. Though not required, but for additional protection, a 1k Ω resistor can be tied from XTAL_IN to ground.

LVC MOS Control Pins

All control pins have internal pulldowns; additional resistance is not required but can be added for additional protection. A 1k Ω resistor can be used.

Outputs:

LVC MOS Outputs

All unused LVC MOS outputs can be left floating. IDT recommends that there be no trace attached.

Wiring the Differential Input to Accept Single-Ended Levels

Figure 2 shows how a differential input can be wired to accept single ended levels. The reference voltage $V_{REF} = V_{DD}/2$ is generated by the bias resistors R1 and R2. The bypass capacitor (C1) is used to help filter noise on the DC bias. This bias circuit should be located as close to the input pin as possible. The ratio of R1 and R2 might need to be adjusted to position the V_{REF} in the center of the input voltage swing. For example, if the input clock swing is 2.5V and $V_{DD} = 3.3V$, R1 and R2 value should be adjusted to set V_{REF} at 1.25V. The values below are for when both the single ended swing and V_{DD} are at the same voltage. This configuration requires that the sum of the output impedance of the driver (R_o) and the series resistance (R_s) equals the transmission line impedance. In addition, matched termination at the input will attenuate the signal in half. This can be done in one of two ways. First, R3 and R4 in parallel should equal the transmission line impedance. For most 50Ω applications, R3 and R4 can be 100Ω. The values of the resistors can be increased to reduce the loading for slower and weaker LVCMOS driver. When using single-ended signaling, the noise rejection benefits of differential signaling are reduced. Even though the differential input can handle full rail LVCMOS signaling, it is recommended that the amplitude be reduced while maintaining an edge rate faster than 1V/ns. The datasheet specifies a lower differential amplitude, however this only applies to differential signals. For single-ended applications, the swing can be larger, however V_{IL} cannot be less than -0.3V and V_{IH} cannot be more than $V_{DD} + 0.3V$. Though some of the recommended components might not be used, the pads should be placed in the layout. They can be utilized for debugging purposes. The datasheet specifications are characterized and guaranteed by using a differential signal.

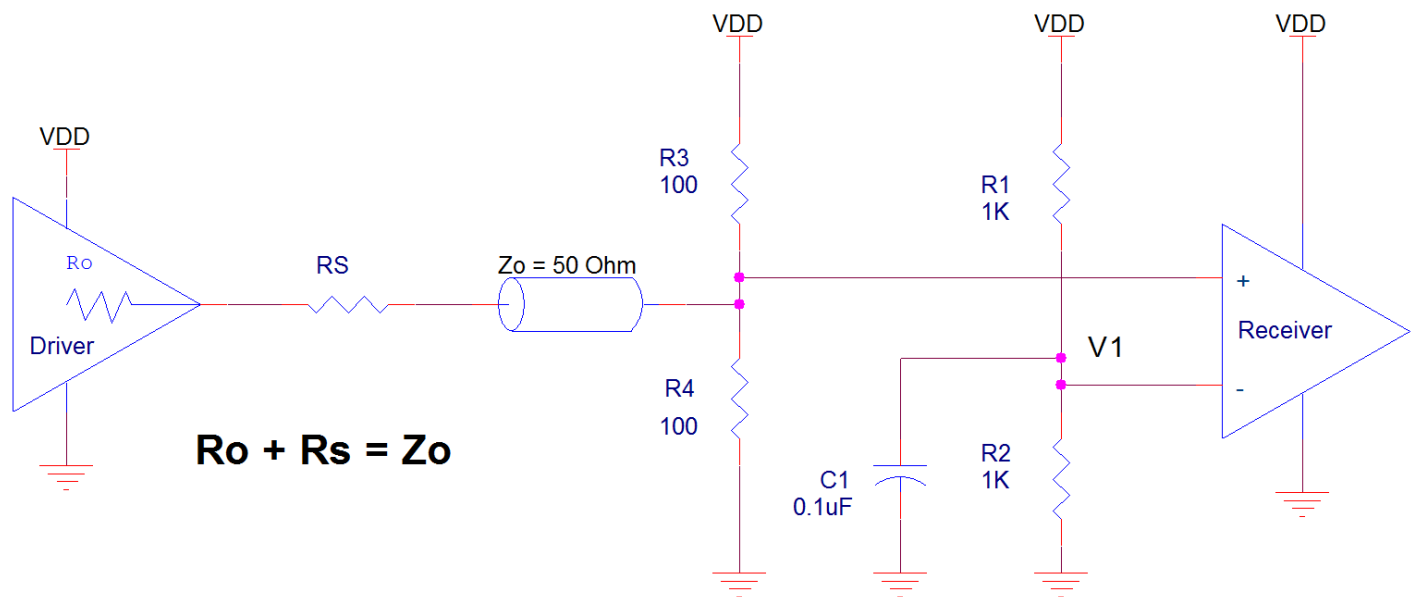

Figure 2. Recommended Schematic for Wiring a Differential Input to Accept Single-ended Levels

Crystal Input Interface

The 8L30205 has been characterized with 12pF parallel resonant crystals. The capacitor values, C1 and C2, shown in Figure 3 below was determined using a 12pF parallel resonant crystal, and was chosen to minimize the ppm error. The optimum C1 and C2 values can be slightly adjusted for different board layouts.

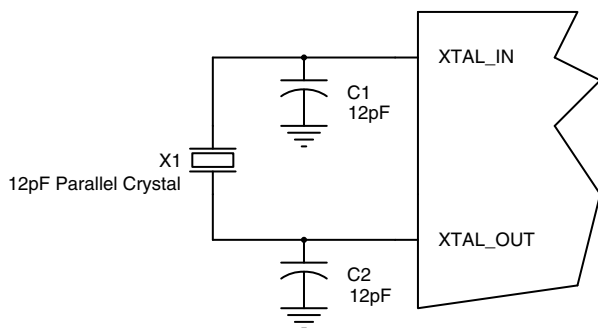

Figure 3. Crystal Input Interface

Overdriving the XTAL Interface

The XTAL_IN input can be overdriven by an LVCMOS driver or by one side of a differential driver through an AC coupling capacitor. The XTAL_OUT pin can be left floating. The amplitude of the input signal should be between 500mV and 1.8V and the slew rate should not be less than 0.2V/nS. For 3.3V LVCMOS inputs, the amplitude must be reduced from full swing to at least half the swing in order to prevent signal interference with the power rail and to reduce internal noise. *Figure 4A* shows an example of the interface diagram for a high speed 3.3V LVCMOS driver. This configuration requires that the sum of the output impedance of the driver (R_o) and the series resistance (R_s) equals the transmission line impedance. In addition, matched termination at the crystal input will attenuate the signal in half. This can be done in one of two ways. First, R_1 and R_2 in parallel should equal the transmission line impedance. For most 50Ω applications, R_1 and R_2 can be 100Ω. This can also be accomplished by removing R_1 and changing R_2 to 50Ω. The values of the resistors can be increased to reduce the loading for a slower and weaker LVCMOS driver. *Figure 4B* shows an example of the interface diagram for an LVPECL driver. This is a standard LVPECL termination with one side of the driver feeding the XTAL_IN input. It is recommended that all components in the schematics be placed in the layout. Though some components might not be used, they can be utilized for debugging purposes. The datasheet specifications are characterized and guaranteed by using a quartz crystal as the input.

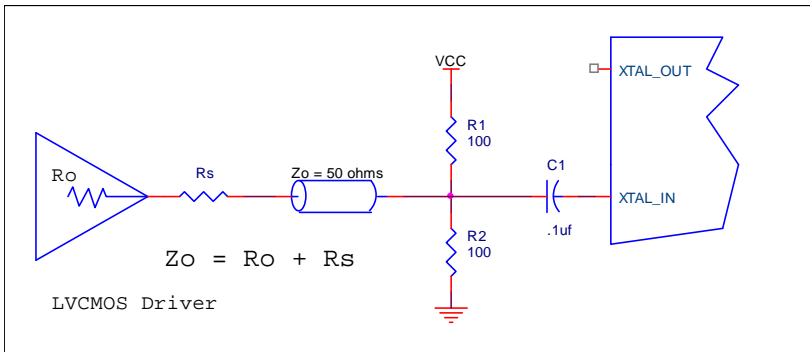

Figure 4A. General Diagram for LVCMOS Driver to XTAL Input Interface

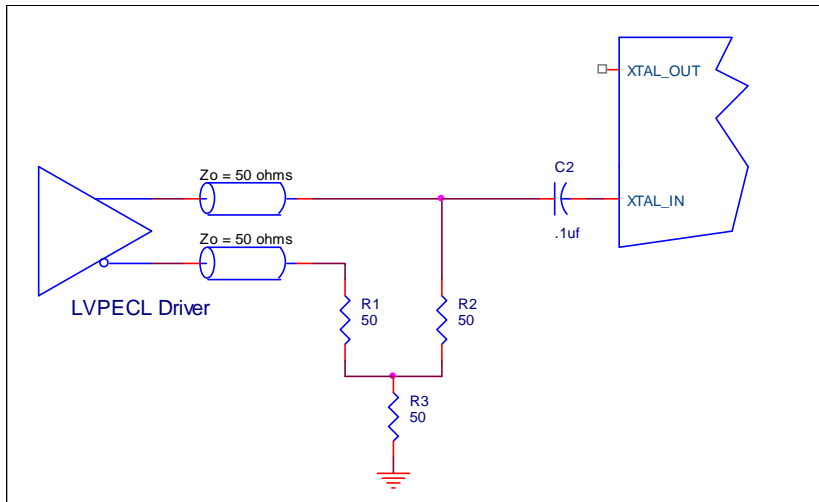

Figure 4B. General Diagram for LVPECL Driver to XTAL Input Interface

Differential Clock Input Interface

The CLK /nCLK accepts LVDS, LVPECL, HCSL and other differential signals. Both signals must meet the V_{PP} and V_{CMR} input requirements. Figures 5A to 5D show interface examples for the CLK /nCLK input with built-in 50Ω terminations driven by the most common driver types. The input interfaces suggested here are examples only. If the driver is from another vendor, use their termination recommendation. Please consult with the vendor of the driver component to confirm the driver termination requirements.

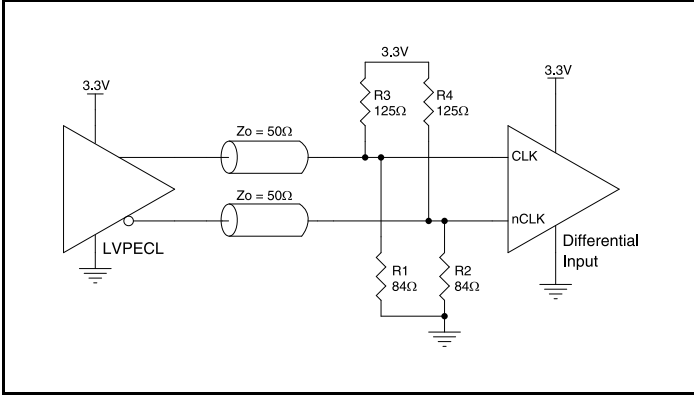

Figure 5A. CLK/nCLK Input Driven by a 3.3V LVPECL Driver

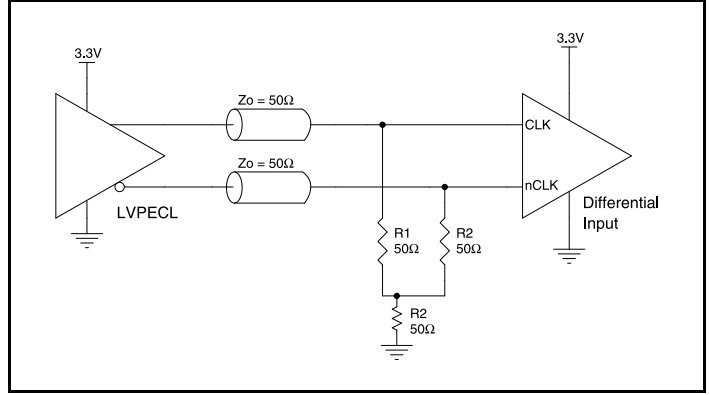

Figure 5B. CLK/nCLK Input Driven by a 3.3V LVPECL Driver

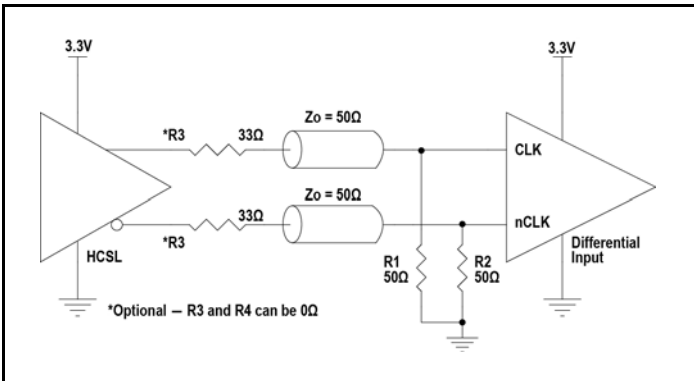

Figure 5C. CLK/nCLK Input Driven by a 3.3V HCSL Driver

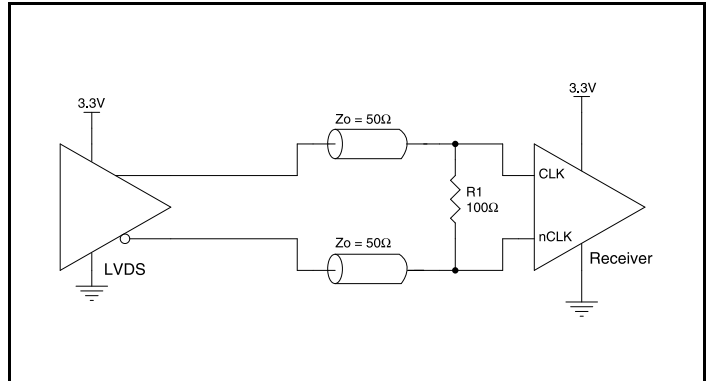

Figure 5D. CLK/nCLK Input Driven by a 3.3V LVDS Driver

VFQFN EPAD Thermal Release Path

In order to maximize both the removal of heat from the package and the electrical performance, a land pattern must be incorporated on the Printed Circuit Board (PCB) within the footprint of the package corresponding to the exposed metal pad or exposed heat slug on the package, as shown in *Figure 6*. The solderable area on the PCB, as defined by the solder mask, should be at least the same size/shape as the exposed pad/slug area on the package to maximize the thermal/electrical performance. Sufficient clearance should be designed on the PCB between the outer edges of the land pattern and the inner edges of pad pattern for the leads to avoid any shorts.

While the land pattern on the PCB provides a means of heat transfer and electrical grounding from the package to the board through a solder joint, thermal vias are necessary to effectively conduct from the surface of the PCB to the ground plane(s). The land pattern must be connected to ground through these vias. The vias act as “heat pipes”. The number of vias (i.e. “heat pipes”) are application specific and dependent upon the package power dissipation as well as electrical conductivity requirements. Thus, thermal and electrical analysis and/or testing are recommended to determine the minimum number needed. Maximum thermal and electrical performance is achieved when an array of vias is incorporated in the land pattern. It is recommended to use as many vias connected to ground as possible. It is also recommended that the via diameter should be 12 to 13mils (0.30 to 0.33mm) with 1oz copper via barrel plating. This is desirable to avoid any solder wicking inside the via during the soldering process which may result in voids in solder between the exposed pad/slug and the thermal land. Precautions should be taken to eliminate any solder voids between the exposed heat slug and the land pattern. Note: These recommendations are to be used as a guideline only. For further information, please refer to the Application Note on the Surface Mount Assembly of Amkor’s Thermally/ Electrically Enhance Lead-frame Base Package, Amkor Technology.

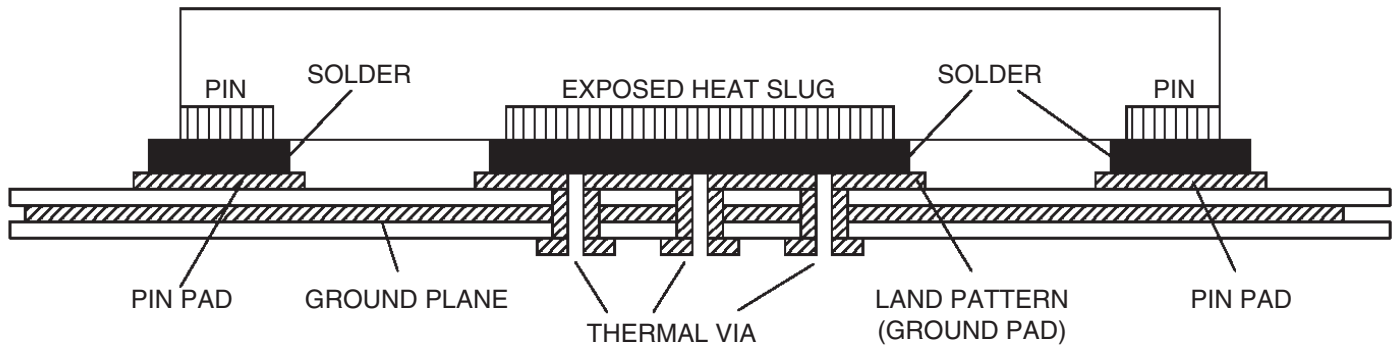

Figure 6. P.C. Assembly for Exposed Pad Thermal Release Path – Side View (drawing not to scale)

Power Considerations

This section provides information on power dissipation and junction temperature for the 8L30205. Equations and example calculations are also provided.

1. Power Dissipation.

The total power dissipation for the 8L30205 is the sum of the core power plus the power dissipation in the load(s). The following is the power dissipation for $V_{DD} = 3.3V + 5\% = 3.465V$, which gives worst case results.

Total Static Power:

$$\text{Power (core)}_{MAX} = V_{DD_MAX} * I_{DD} = 3.465V * 19mA = \mathbf{65.835mW}$$

Dynamic Power Dissipation at F_{OUT} (200MHz)

$$\text{Total Power (F}_{OUT_MAX}) = [(C_{PD} * N) * \text{Frequency} * (V_{DDO})^2] = [(11pF * 5) * 200MHz * (3.465V)^2] = \mathbf{133mW}$$

N = number of outputs

Total Power

$$\begin{aligned} &= \text{Static Power} + \text{Dynamic Power Dissipation} \\ &= 65.835mW + 133mW \\ &= \mathbf{198.835mW} \end{aligned}$$

2. Junction Temperature.

Junction temperature, T_j , is the temperature at the junction of the bond wire and bond pad, and directly affects the reliability of the device. The maximum recommended junction temperature is 125°C. Limiting the internal transistor junction temperature, T_j , to 125°C ensures that the bond wire and bond pad temperature remains below 125°C.

The equation for T_j is as follows: $T_j = \theta_{JA} * Pd_total + T_A$

T_j = Junction Temperature

θ_{JA} = Junction-to-Ambient Thermal Resistance

Pd_total = Total Device Power Dissipation (example calculation is in section 1 above)

T_A = Ambient Temperature

In order to calculate junction temperature, the appropriate junction-to-ambient thermal resistance θ_{JA} must be used. Assuming no air flow and a multi-layer board, the appropriate value is 37.07°C/W per Table 7 below.

Therefore, T_j for an ambient temperature of 85°C with all outputs switching is:

$$85^\circ\text{C} + 0.199 * 37.07^\circ\text{C/W} = 92.4^\circ\text{C}. \text{ This is below the limit of } 125^\circ\text{C}.$$

This calculation is only an example. T_j will obviously vary depending on the number of loaded outputs, supply voltage, air flow and the type of board (multi-layer).

Table 7. Thermal Resistance θ_{JA} for 24 Lead VFQFN, Forced Convection

Meters per Second	θ_{JA} by Velocity		
	0	1	2
Multi-Layer PCB, JEDEC Standard Test Boards	37.07°C/W	33.6°C/W	32.0°C/W

Case Temperature Considerations

This device supports applications in a natural convection environment which does not have any thermal conductivity through ambient air. The printed circuit board (PCB) is typically in a sealed enclosure without any natural or forced air flow and is kept at or below a specific temperature. The device package design incorporates an exposed pad (ePad) with enhanced thermal parameters which is soldered to the PCB where most of the heat escapes from the bottom exposed pad. For this type of application, it is recommended to use the junction-to-board thermal characterization parameter Ψ_{JB} (Psi-JB) to calculate the junction temperature (T_J) and ensure it does not exceed the maximum allowed junction temperature in the Absolute Maximum Rating table.

The junction-to-board thermal characterization parameter, Ψ_{JB} , is calculated using the following equation:

$T_J = T_{CB} + \Psi_{JB} \times P_d$, Where

T_J = Junction temperature at steady state condition in ($^{\circ}\text{C}$).

T_{CB} = Case temperature (Bottom) at steady state condition in ($^{\circ}\text{C}$).

Ψ_{JB} = Thermal characterization parameter to report the difference between junction temperature and the temperature of the board measured at the top surface of the board.

P_d = power dissipation (W) in desired operating configuration.

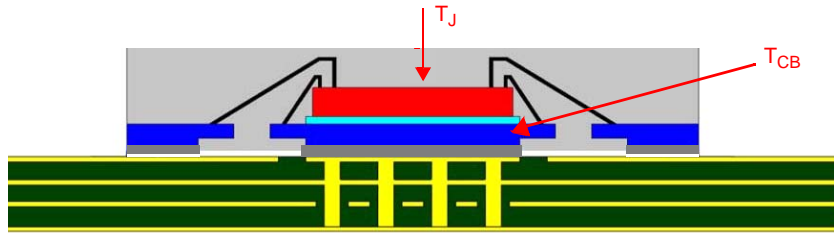

The ePad provides a low thermal resistance path for heat transfer to the PCB and represents the key pathway to transfer heat away from the IC to the PCB. It's critical that the connection of the exposed pad to the PCB is properly constructed to maintain the desired IC case temperature (T_{CB}). A good connection ensures that temperature at the exposed pad (T_{CB}) and the board temperature (T_B) are relatively the same. An improper connection can lead to increased junction temperature, increased power consumption and decreased electrical performance. In addition, there could be long-term reliability issues and increased failure rate.

Example Calculation for Junction Temperature (T_J): $T_J = T_{CB} + \Psi_{JB} \times P_d$

Package type:	24-Lead VFQFN
Body size:	4mm x 4mm x 0.9mm
ePad size:	2.6mm x 2.6mm
Thermal Via:	4 x 4 matrix
Ψ_{JB}	2.36 C/W
T_{CB}	105 $^{\circ}\text{C}$
P_d	0.199 W

For the variables above, the junction temperature is equal to 105.5 $^{\circ}\text{C}$. Since this is below the maximum junction temperature of 125 $^{\circ}\text{C}$, there are no long term reliability concerns.

Reliability Information

Table 8. θ_{JA} vs. Air Flow Table for a 24 Lead VFQFN

θ_{JA} vs. Air Flow			
Meters per Second	0	1	2
Multi-Layer PCB, JEDEC Standard Test Boards	37.07°C/W	33.6°C/W	32.0°C/W

Transistor Count

The transistor count for 8L30205 is: 1,638

REV	DESCRIPTION
00	INITIAL RELEASE
01	CORRECT TITLE

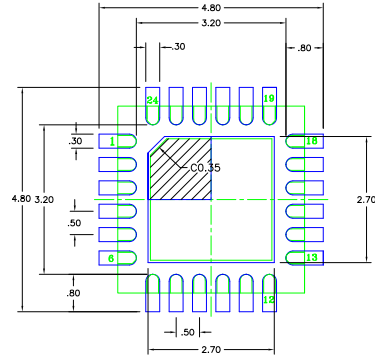

RECOMMENDED LAND PATTERN DIMENSION

NOTES:

1. ALL DIMENSIONS ARE IN mm. ANGLES IN DEGREES.
2. TOP DOWN VIEW, AS VIEWED ON PCB.
3. COMPONENT OUTLINE SHOWS FOR REFERENCE IN GREEN.
4. LAND PATTERN IN BLUE. NSMD PATTERN ASSUMED.
5. LAND PATTERN RECOMMENDATION PER IPC-7351B GENERIC REQUIREMENT FOR SURFACE MOUNT DESIGN AND LAND PATTERN.

TOLERANCES UNLESS SPECIFIED		TITLEN/	SIZE	D
DECIMAL	ANGULAR			
XX±	±		4.0	
XXX±			0.5	
XXXX±				
APPROVALS	DATE			
DRAWN <i>BA/C</i>	11/17/15			
CHECKED				
			C	
				DO NOT

Ordering Information

Part/Order Number	Marking	Package	Shipping Packaging	Temperature
8L30205NLGI	0205GI	24 Lead VFQFN, Lead-Free	Tray	-40°C to 85°C
8L30205NLGI8	0205GI	24 Lead VFQFN, Lead-Free	Tape & Reel	-40°C to 85°C

Revision History

Revision Date	Description of Change
May 3, 2017	<ul style="list-style-type: none">▪ Table 4C - added V_{IH} max specs.▪ Updated Package Drawings.▪ Updated datasheet header/footer.

IMPORTANT NOTICE AND DISCLAIMER

RENESAS ELECTRONICS CORPORATION AND ITS SUBSIDIARIES (“RENESAS”) PROVIDES TECHNICAL SPECIFICATIONS AND RELIABILITY DATA (INCLUDING DATASHEETS), DESIGN RESOURCES (INCLUDING REFERENCE DESIGNS), APPLICATION OR OTHER DESIGN ADVICE, WEB TOOLS, SAFETY INFORMATION, AND OTHER RESOURCES “AS IS” AND WITH ALL FAULTS, AND DISCLAIMS ALL WARRANTIES, EXPRESS OR IMPLIED, INCLUDING, WITHOUT LIMITATION, ANY IMPLIED WARRANTIES OF MERCHANTABILITY, FITNESS FOR A PARTICULAR PURPOSE, OR NON-INFRINGEMENT OF THIRD PARTY INTELLECTUAL PROPERTY RIGHTS.

These resources are intended for developers skilled in the art designing with Renesas products. You are solely responsible for (1) selecting the appropriate products for your application, (2) designing, validating, and testing your application, and (3) ensuring your application meets applicable standards, and any other safety, security, or other requirements. These resources are subject to change without notice. Renesas grants you permission to use these resources only for development of an application that uses Renesas products. Other reproduction or use of these resources is strictly prohibited. No license is granted to any other Renesas intellectual property or to any third party intellectual property. Renesas disclaims responsibility for, and you will fully indemnify Renesas and its representatives against, any claims, damages, costs, losses, or liabilities arising out of your use of these resources. Renesas' products are provided only subject to Renesas' Terms and Conditions of Sale or other applicable terms agreed to in writing. No use of any Renesas resources expands or otherwise alters any applicable warranties or warranty disclaimers for these products.

(Rev.1.0 Mar 2020)

Corporate Headquarters

TOYOSU FORESIA, 3-2-24 Toyosu,
Koto-ku, Tokyo 135-0061, Japan
www.renesas.com

Contact Information

For further information on a product, technology, the most up-to-date version of a document, or your nearest sales office, please visit:
www.renesas.com/contact/

Trademarks

Renesas and the Renesas logo are trademarks of Renesas Electronics Corporation. All trademarks and registered trademarks are the property of their respective owners.

X-ON Electronics

Largest Supplier of Electrical and Electronic Components

Click to view similar products for [Clock Buffer](#) category:

Click to view products by [Renesas](#) manufacturer:

Other Similar products are found below :

[MPC962309EJ-1H](#) [NB4N121KMNG](#) [IDT49FCT805ASO](#) [MK2308S-1HILF](#) [PL133-27GI-R](#) [NB3L02FCT2G](#) [NB3L03FCT2G](#)
[ZL40203LDG1](#) [ZL40200LDG1](#) [ZL40205LDG1](#) [9FG1200DF-1LF](#) [9FG1001BGLF](#) [ZL40202LDG1](#) [PI49FCT20802QE](#) [SL2305SC-1T](#)
[PI6C4931502-04LIE](#) [NB7L1008MNG](#) [NB7L14MN1G](#) [PI49FCT20807QE](#) [PI6C4931502-04LIEX](#) [ZL80002QAB1](#) [PI6C4931504-04LIEX](#)
[PI6C10806BLEX](#) [ZL40226LDG1](#) [ZL40219LDG1](#) [8T73S208B-01NLGI](#) [SY75578LMG](#) [PI49FCT32805QEX](#) [PL133-27GC-R](#)
[CDCV304PWG4](#) [MC10LVEP11DG](#) [MC10EP11DTG](#) [MC100LVEP11DG](#) [MC100E111FNG](#) [MC100EP11DTG](#) [NB6N11SMNG](#)
[NB7L14MMNG](#) [NB6L11MMNG](#) [NB6L14MMNR2G](#) [NB6L611MNG](#) [PL123-02NGI-R](#) [NB3N111KMNR4G](#) [ADCLK944BCPZ-R7](#)
[ZL40217LDG1](#) [NB7LQ572MNG](#) [HMC940LC4BTR](#) [ADCLK946BCPZ-REEL7](#) [ADCLK946BCPZ](#) [ADCLK846BCPZ-REEL7](#)
[ADCLK905BCPZ-R2](#)