

Description

The 8V19N850 is a fully integrated Radio Unit Clock Synchronizer and Converter Clock Generator designed as a high-performance clock solution for phase/frequency synchronization and signal conditioning of wireless base station radio equipment. The device supports JESD204B/C subclass 0 and 1 device clocks and SYSREF synchronization for converters.

The 8V19N850 supports two independent frequency domains: one that can be used for the digital clock (Ethernet and FEC rates) domain with four outputs, and the device clock (RF-PLL) domain with 12 outputs. The Ethernet domain generates frequencies from two independent APLLs for flexibility; the outputs of the RF clock domain generate very low phase noise clocks for ADC/DAC circuits.

From the integrated RF-PLL, the device supports the clock generation of high-frequency device clocks for driving ADC/DAC devices low-frequency synchronization signals (SYSREF).

A dual DPLL front-end architecture supports any frequency translation. Each DPLL provides a programmable bandwidth and a DCO function for real-time frequency/phase adjustments. The DPLLs can lock on 1PPS input signals and establish lock within 100s or less. Frequency information can be applied from DPLL-0 to DPLL-1 and vice versa to enable the combining of the frequency characteristics of two references (combo-mode).

The 8V19N850 is configured through a pin-mapped I3CSM (including legacy I²C) and 3/4-wire SPI interface. I²C with master capabilities reads a default configuration from an external ROM device. GPIO ports can be configured for reporting and controlling purposes.

Applications

- Wireless infrastructure 5G radio

Simplified Block Diagram

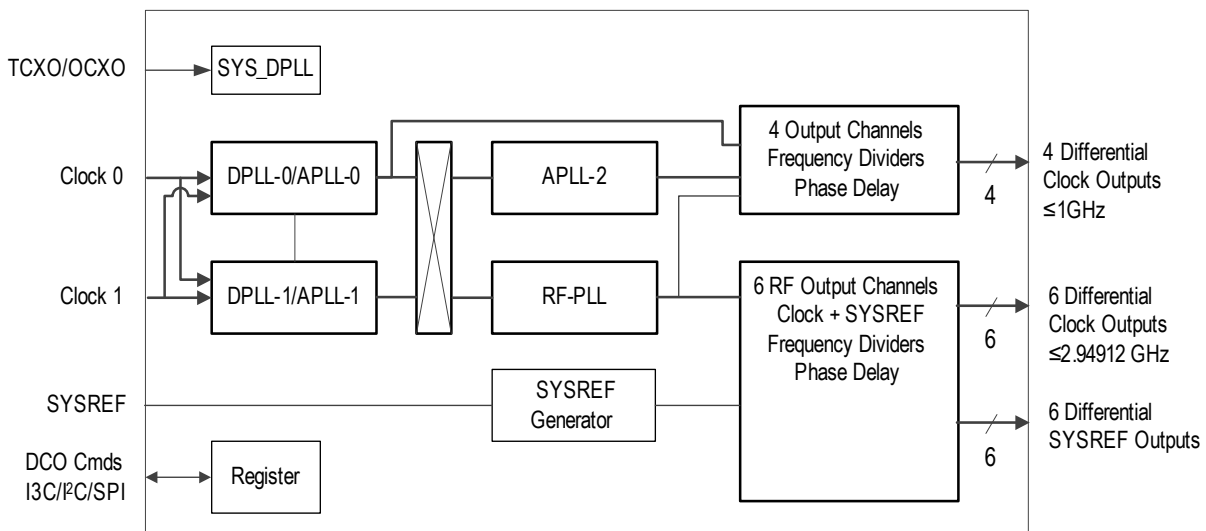

Features

- High-performance radio clock synchronizer clock
 - Device clock domain (RF-PLL) with support for JESD204B/C
 - Digital clock domain (Ethernet, FEC) with support for eEEEC and T-BC/T-TSC Class C
- 2 differential clock reference inputs
 - 1PPS (1Hz) to 1GHz input frequency
- Dual DPLL front-end with independent clock paths
 - External control of the DCO for IEEE1588
 - Digital holdover with a 1.1×10^{-7} ppb accuracy
 - Programmable DPLL loop bandwidth 1mHz - 6kHz
 - Configurable phase delay (range: 1UI)
 - Hitless input switching with < 1ns output phase error
- Reference monitors for input LOS, activity and frequency
- 1 external synchronization input for JESD204B/C (LVCMOS)
- 16 differential outputs
- Dedicated phase management capabilities
- Optimized for low phase noise:
 - Device clocks: -149.9dBc/Hz (1MHz offset; 245.76MHz clock)
- Supply voltage (core): 3.3V; (outputs): 3.3V, 2.5V, and 1.8V
- Package: 10 × 10 mm 88-VFQFPN
- Board temperature range: -40°C to +105°C

Applicable Standards

- ITU-T G.8262 EEC1/2, G.8262.1 eEEEC
- ITU-T G.8273.2 T-BC/T-TSC Class C
- JESD204B and C

Block Diagram

Figure 1. Block Diagram

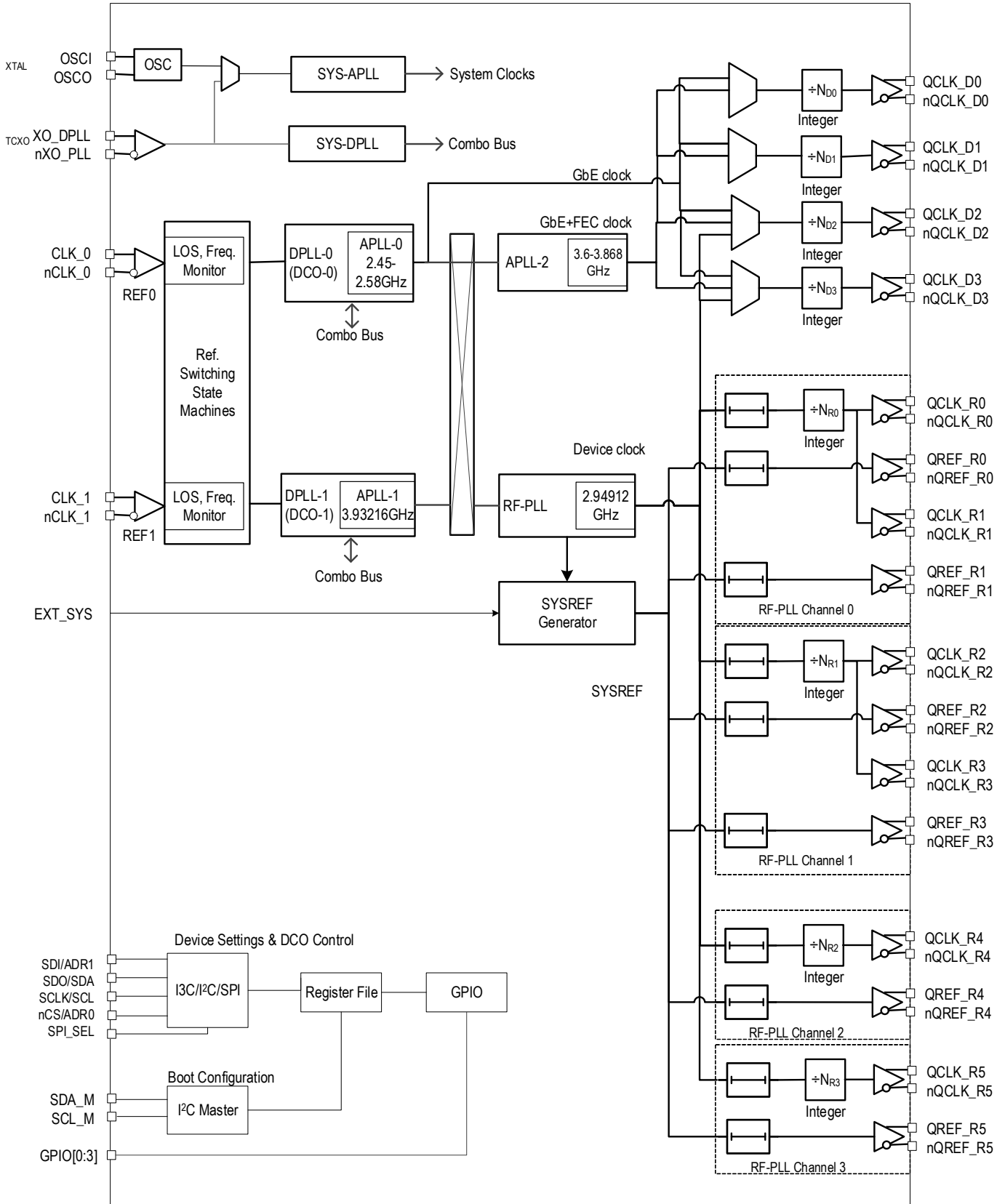

Features (Full List)

- High-performance radio clock synchronizer clock
 - Device clock domain (RF-PLL) with support for JESD204B/C
 - Digital clock domain (Ethernet, FEC) with support for eEEEC and T-BC/T-TSC Class C
- Dual DPLL front-end with independent clock paths
 - Compliant to ITU-T G.8262 (EEC1/2), G.8262.1 (eEEEC), and G.8273.2 (T-BC/T-TSC)
 - External control of the DCO for IEEE1588 (with a resolution of 1.1×10^{-7} ppb)
 - Reference monitors for input LOS, activity and frequency
 - Fast lock to input signals, incl. 1PPS lock
 - Digital holdover with a 1.1×10^{-7} ppb accuracy
 - Programmable DPLL loop bandwidth 1mHz - 6kHz
 - Configurable phase delay (range: 1UI)
 - Hitless input switching with < 1 ns output phase error
- 2 differential clock reference inputs
 - LVDS and LVPECL compatible, non-inverted input also supports LVCMOS
 - 1PPS (1Hz) to 1GHz input frequency
- 1 external synchronization input for JESD204B/C (LVCMOS)
- 16 differential outputs
 - 12 device clock domain outputs (from RF-PLL), 6 clock and 6 SYSREF outputs
 - 4 digital clock domain outputs
 - Low-power LVPECL/LVDS outputs support configurable signal amplitude, DC and AC coupling and LVPECL, LVDS line terminations techniques
 - Device clock outputs programmable in output amplitude
 - Frequency range: 0.4608MHz–2.94912GHz (RF-PLL) and up to 1GHz (Digital clocks)
 - 1PPS (Digital clocks) for T-BC/T-TSC
- Dedicated phase management capabilities
 - Static phase delay for every device clock and SYSREF output
 - Static and dynamically adjustable phase delay in each DPLL
 - Supports less than ± 0.5 ns input to output phase offset
- Optimized for low phase noise
 - Device clocks (RF-PLL): -149.9 dBc/Hz (1MHz offset; 245.76MHz clock)
- Serial interface ports
 - 3/4-wire SPI or 2-wire I²C (including legacy I²C), pin-mapped, for phase/frequency control and other configurations
 - Single I²C master boot for obtaining a start-up configuration
 - Serial control I/O voltage: 1.8V (outputs: selectable 1.8/3.3V voltage)
- Supply voltage (core): 3.3V; (outputs): 3.3V, 2.5V, and 1.8V
- Package: 10 × 10 mm 88-VFQFPN
- Board temperature range: -40°C to $+105^{\circ}\text{C}$

Contents

Description	1
Applications	1
Simplified Block Diagram	1
Features	1
Applicable Standards	1
Block Diagram	2
Features (Full List)	3
Contents	4
Pinout	7
Pin Descriptions	8
Principles of Operation	12
Signal Flow	12
One and Two Frequency Domains	12
Three Frequency Domains	14
System APLL (SYS-APLL)	15
System DPLL (SYS-DPLL)	16
Digital PLLs (DPLL-0, DPLL-1)	17
DPLL-0 Frequency Plan	17
DPLL-1 Frequency Plan	18
DPLL-0/DPLL-1 Operation States	19
DPLL Loop Bandwidth	21
Holdover State	21
Pull-in/Hold-in	22
Free-Run Frequency Accuracy	22
Phase Slope Limiting (PSL)	22
IEEE 1588 Modes of operation	22
Phase Adjustment through DPLL	26
Input Clock Qualification and Reference Selection	26
Pin Selection Mode	27
Manual Selection Mode	27
Automatic Input Clock Selection Mode	28
Reference Switching	28
1PPS Fast Lock	32
Input to Output Phase Alignment	32
Input Disqualification by GPIO pins	34
APLL-2	34
Frequency Plan	34
Crystal Oscillator Interface (XO_DPLL/nXO_DPLL)	35
Crystal Interface (OSCI/OSCO)	35
Digital Frequency Domains	35
Converter Clock Domain and RF-PLL	36
RF-PLL Channel	36
RF-PLL Channel Frequency Divider	37
Configuration for JESD204B Operation	38
Differential Outputs	40
Output Phase-Delay	42
General Purpose Input/Outputs (GPIOs)	42
Power-up and Internal Reset	48

Power Supply Sequence	48
Automatic Startup and Self-Configuration	48
Serial Port Description	54
SPI Interface (SPI_SEL = 1)	54
I3C Interface (SPI_SEL = 0)	57
I2C Master Interface	58
Configuration and Status Registers	60
General Device Configuration	60
General Power Down Registers	62
Read EEPROM Status	63
I/O Voltage Select Configuration	63
System APLL (SYS-APLL) Configuration	64
System DPLL (SYS-DPLL) Configuration	65
System DPLL (SYS-DPLL) Lock Threshold, Lock Timer, Bandwidth	66
System DPLL (SYS-DPLL) Phase Error Compensation (PEC) and Frequency Divider	68
Reference Monitor for Input CLK_0	69
Reference Monitor for Input CLK_1	73
Global Status	77
DPLL-0 (APLL-0) Frequency Configuration	82
DPLL-0 (APLL-0) DSM Control and APLL-0 Charge Pump Configuration	84
DPLL-0 Feedback Divider M0	86
DPLL-0 Frequency Control	87
DPLL-0 Lock Timer	88
DPLL-0 Hitless Switch	88
DPLL-0 Mode Control	89
DPLL-0 Phase Offset, Write Phase and Frequency	91
DPLL-0 Reference State	92
DPLL-0 Lock Threshold, Lock Timer, Bandwidth	94
DPLL-0 Phase Slope Limiting	96
DPLL-0 Holdover, Phase Error Compensation (PEC)	97
DPLL-0 Fractional Feedback Divider M1	99
DPLL-1 (APLL-1) Frequency Configuration	100
DPLL-1 (APLL-1) DSM Control and APLL-1 Charge Pump Configuration	102
DPLL-1 Lock Timer	105
DPLL-1 Hitless Switch	105
DPLL-1 Mode Control	106
DPLL-1 Phase Offset, Write Phase and Frequency	108
DPLL-1 Reference State	110
DPLL-1 Lock Threshold, Lock Timer, Bandwidth	112
DPLL-1 Phase Slope Limiting	114
DPLL-1 Holdover, Phase Error Compensation (PEC)	115
DPLL-1 Fractional Feedback Divider M1	117
APLL-2 Configuration Registers	118
RF-PLL Configuration Registers	121
SYSREF Registers	124
Channel D0-D3 and R0-R3 Registers	127
Output Registers	134
GPIO Registers	138
Device Status	141

DPLL-0/DPLL-1/APLL-2/RF-PLL Status	142
Initialization and Internal SYSREF Trigger	143
Channel Enable and PLL Reference Registers Descriptions	145
Electrical Characteristics	147
Absolute Maximum Ratings	147
Pin Characteristics	148
External Oscillator Characteristics	148
DC Characteristics	149
AC Characteristics	153
Application Information	166
Termination for QCLK_y, QREF_r LVDS Outputs (STYLE = 0)	166
AC Termination for QCLK_y, QREF_r LVDS Outputs (STYLE = 0)	166
Termination for QCLK_y, QREF_r LVPECL Outputs (STYLE = 1)	167
Thermal Characteristics	168
Case Temperature Considerations	168
Package Exposed Pad Thermal Release Path	169
Package Outline Drawings	169
Marking Diagram	169
Ordering Information	170
Glossary	171
Errata	172
Revision History	172

Pinout

Figure 2. Pinout 10 x 10 mm² 88-VFQFPN Package (Top View)

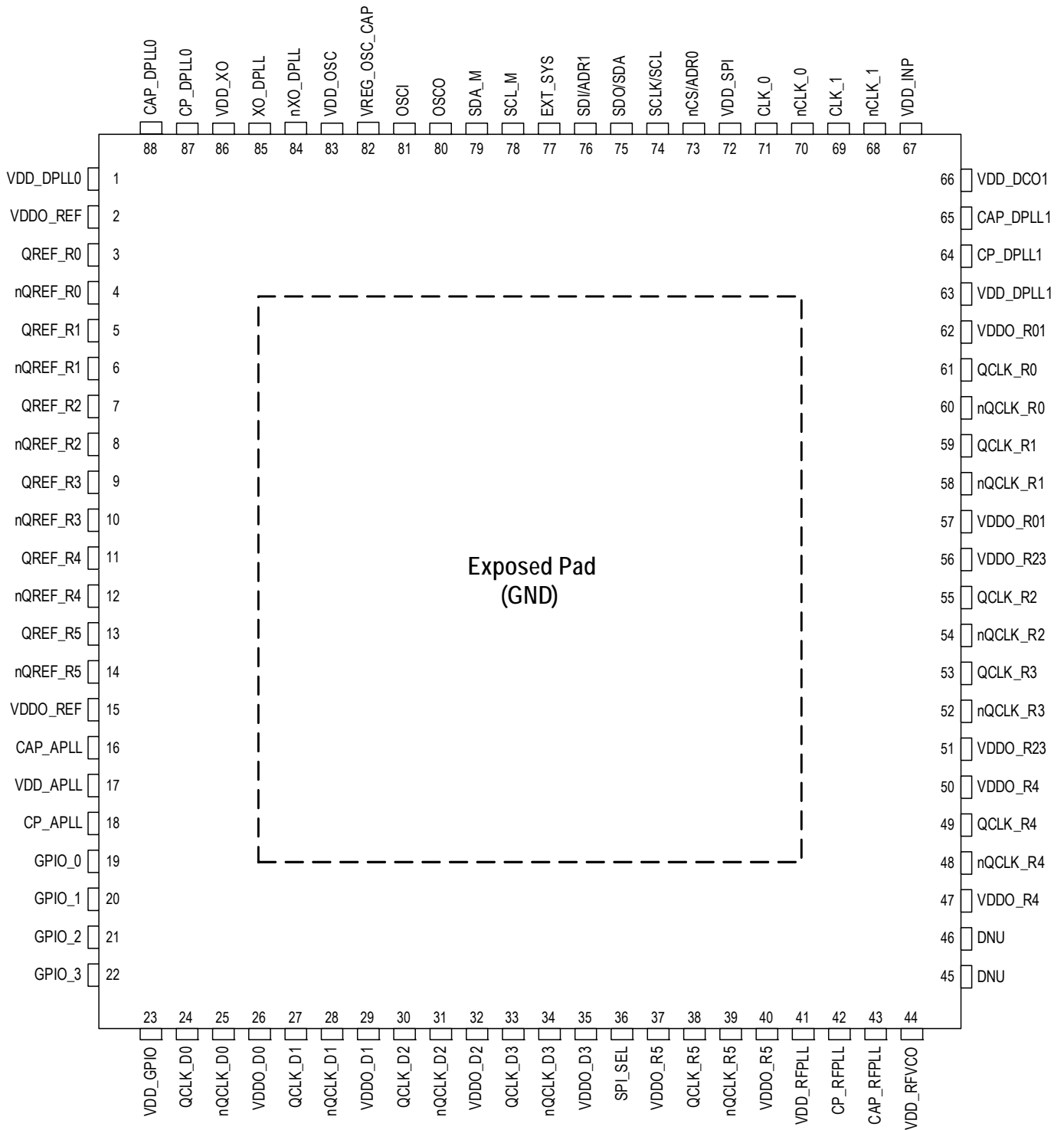

Pin Descriptions

Table 1. Pin Descriptions^a

Pin	Name	Type ^b		Description
Signal Inputs				
71	CLK_0	Input	PD	Device clock 0 inverting and non-inverting differential clock input. Inverting input is biased to $V_{DD_V}/2$ by default when left floating. Compatible with LVPECL, LVDS, and LVCMOS signals.
70	nCLK_0		PD/PU	
69	CLK_1	Input	PD	Device clock 1 inverting and non-inverting differential clock input. Inverting input is biased to $V_{DD_V}/2$ by default when left floating. Compatible with LVPECL, LVDS, and LVCMOS signals.
68	nCLK_1		PD/PU	
85	XO_DPLL	Input	PD	Single-ended or differential crystal oscillator input for the system DPLL (SYS-DPLL) and for the SYS-APLL (selectable). May also be a reference to APLL-0 and APLL-1. For a frequency specification, see Table 132 . Inverting input is biased to $V_{DD_V}/2$ by default when left floating. Compatible with LVPECL, LVDS, and LVCMOS signals.
84	nXO_DPLL		PD/PU	
81	OSCI	Input		XTAL interface of the system APLL (SYS-APLL) and reference to APLL-0 and APLL-1. It is also a reference for APLL-2 when APLL-2 is used as part of the system DPLL (SYS-DPLL). For a frequency and interface specification, see Table 132 . OSCI should be AC-coupled, if an oscillator (XO) is used on OSCI, leave OSCO unconnected.
80	OSCO	Output		
77	EXT_SYS	Input	PD	External SYSREF pulse trigger input. 1.8V LVCMOS interface levels (3.3V tolerant)
36	SPI_SEL	Input	PU	SPI/I3C Select. 1.8V/2.5V/3.3V LVCMOS interface levels. For levels, see Table 134 .
Signal Outputs				
61, 60	QCLK_R0, nQCLK_R0	Output		Differential clock output R0 (Device clock from RF-PLL, Channel 0). Configurable LVPECL/LVDS style, offset voltage and amplitude. 3.3V, 2.5V, or 1.8V output voltage supply.
59, 58	QCLK_R1, nQCLK_R1	Output		Differential clock output R1 (Device clock from RF-PLL, Channel 0). Configurable LVPECL/LVDS style, offset voltage and amplitude. 3.3V, 2.5V, or 1.8V output voltage supply.
55, 54	QCLK_R2, nQCLK_R2	Output		Differential clock output R2 (Device clock from RF-PLL, Channel 1). Configurable LVPECL/LVDS style, offset voltage and amplitude. 3.3V, 2.5V, or 1.8V output voltage supply.
53, 52	QCLK_R3, nQCLK_R3	Output		Differential clock output R3 (Device clock from RF-PLL, Channel 1). Configurable LVPECL/LVDS style, offset voltage and amplitude. 3.3V, 2.5V, or 1.8V output voltage supply.
49, 48	QCLK_R4, nQCLK_R4	Output		Differential clock output R4 (Device clock from RF-PLL, Channel 2). Configurable LVPECL/LVDS style, offset voltage and amplitude. 3.3V, 2.5V, or 1.8V output voltage supply.
38, 39	QCLK_R5, nQCLK_R5	Output		Differential clock output R5 (Device clock from RF-PLL, Channel 3). Configurable LVPECL/LVDS style, offset voltage and amplitude. 3.3V, 2.5V, or 1.8V output voltage supply.
3, 4	QREF_R0, nQREF_R0	Output		Differential SYSREF output R0 (RF-PLL, Channel 0). Configurable LVPECL/LVDS style, offset voltage and amplitude. 3.3V, 2.5V, or 1.8V output voltage supply.

Table 1. Pin Descriptions^a

Pin	Name	Type ^b		Description
5, 6	QREF_R1, nQREF_R1	Output		Differential SYSREF output R1 (RF-PLL, Channel 0). Configurable LVPECL/LVDS style, offset voltage and amplitude. 3.3V, 2.5V, or 1.8V output voltage supply.
7, 8	QREF_R2, nQREF_R2	Output		Differential SYSREF output R2 (RF-PLL, Channel 1). Configurable LVPECL/LVDS style, offset voltage and amplitude. 3.3V, 2.5V, or 1.8V output voltage supply.
9, 10	QREF_R3, nQREF_R3	Output		Differential SYSREF output R3 (RF-PLL, Channel 1). Configurable LVPECL/LVDS style, offset voltage and amplitude. 3.3V, 2.5V, or 1.8V output voltage supply.
11, 12	QREF_R4, nQREF_R4	Output		Differential SYSREF output R4 (RF-PLL, Channel 2). Configurable LVPECL/LVDS style, offset voltage and amplitude. 3.3V, 2.5V, or 1.8V output voltage supply.
13, 14	QREF_R5, nQREF_R5	Output		Differential SYSREF output R5 (RF-PLL, Channel 3). Configurable LVPECL/LVDS style, offset voltage and amplitude. 3.3V, 2.5V, or 1.8V output voltage supply.
24, 25	QCLK_D0, nQCLK_D0	Output		Differential clock output D0 (Digital clock). Configurable LVPECL/LVDS/LVCMOS style and amplitude. 3.3V, 2.5V, or 1.8V output voltage.
27, 28	QCLK_D1, nQCLK_D1	Output		Differential clock output D1 (Digital clock). Configurable LVPECL/LVDS/LVCMOS style and amplitude. 3.3V, 2.5V, or 1.8V output voltage.
30, 31	QCLK_D2, nQCLK_D2	Output		Differential clock output D2 (Digital clock). Configurable LVPECL/LVDS/LVCMOS style and amplitude. 3.3V, 2.5V, or 1.8V output voltage.
33, 34	QCLK_D3, nQCLK_D3	Output		Differential clock output D3 (Digital clock). Configurable LVPECL/LVDS/LVCMOS style and amplitude. 3.3V, 2.5V, or 1.8V output voltage.
Serial Interface 0				
76	SDI/SDIO/ADR1	Input/Output	—	SPI: Data Input in 4-wire mode (SDI) or Data Input/Output in 3-wire mode (SDIO). 1.8V interface levels with hysteresis and 3.3V tolerance. When output, selectable 1.8V/3.3V levels. I3C: Static address bit input and part of the 48-bit unique ID.
75	SDO/SDA	Input/Output	—	SPI: Data Output in 4-wire mode (SDO). Selectable 1.8V/3.3V output levels I3C: Data I/O (SDA). 1.8V interface levels with hysteresis and 3.3V tolerance
74	SCLK/SCL	Input	—	SPI: Clock Input. 1.8V interface levels with hysteresis and 3.3V tolerance. I3C: Clock Input / SPI Clock Input.
73	nCS/ADR0	Input	—	SPI: Chip Select Input. 1.8V interface levels with hysteresis and 3.3V tolerance. I3C: Static address bit input and part of 48-bit unique ID.
Serial Interface 1				
79	SDA_M	Input/Output	—	Serial Control Port I ² C (Master) Data Input/Output. 1.8V interface levels with hysteresis and 3.3V tolerance. Open collector when output. External resistor (pull high) is required if pin is not used.
78	SCL_M	Output	—	Serial Control Port I ² C (Master) Clock Output. Open-collector / 1.8V interface levels with hysteresis and 3.3V tolerance. External resistor (pull high) is required if pin is not used.

Table 1. Pin Descriptions^a

Pin	Name	Type ^b		Description
GPIO				
19	GPIO_0	Input/Output	PU	General purpose I/O port. Selectable 1.8V/3.3V LVCMOS interface levels. 3.3V tolerant when configured as input and set to 1.8V logic levels.
20	GPIO_1	Input/Output	PD	
21	GPIO_2	Input/Output	PD	
22	GPIO_3	Input/Output	PD	
PLL Circuit Connections				
18	CP_APLL			APLL-2 loop filter.
42	CP_RFPLL			RF-PLL loop filter.
87	CP_DPLL0			APLL-0 loop filter.
64	CP_DPLL1			APLL-1 loop filter.
16	CAP_APLL			Bypass capacitor (1μF to GND) for the internal regulator for the APLL-2 block.
43	CAP_RFPLL			Bypass capacitor (1μF to GND) for internal regulator for the RF-PLL block.
88	CAP_DPLL0			Bypass capacitor (1μF to GND) for internal regulator for the DPLL-0 block.
65	CAP_DPLL1			Bypass capacitor (1μF to GND) for internal regulator for the DPLL-1 block.
82	VREG_OSC_CAP			Bypass capacitor (1μF to GND) for internal regulator for the OSC block.
Power and Ground				
2, 15	VDDO_REF	Power		Positive supply voltage (3.3V) for the QREF_R0-QREF_R5 outputs. Supplied with 3.3V, 2.5V, or 1.8V
35	VDDO_D3	Power		Positive supply voltage (3.3V) for the QCLK_D3 outputs. Supplied with 3.3V, 2.5V, or 1.8V.
32	VDDO_D2	Power		Positive supply voltage (3.3V) for the QCLK_D2 outputs. Supplied with 3.3V, 2.5V, or 1.8V.
29	VDDO_D1	Power		Positive supply voltage (3.3V) for the QCLK_D1 outputs. Supplied with 3.3V, 2.5V, or 1.8V.
26	VDDO_D0	Power		Positive supply voltage (3.3V) for the QCLK_D0 outputs. Supplied with 3.3V, 2.5V, or 1.8V.
57, 62	VDDO_R01	Power		Positive supply voltage (3.3V) for the QCLK_R0 and QCLK_R1 outputs. Supplied with 3.3V, 2.5V, or 1.8V.
51, 56	VDDO_R23	Power		Positive supply voltage (3.3V) for the QCLK_R2 and QCLK_R3 outputs. Supplied with 3.3V, 2.5V, or 1.8V.
47, 50	VDDO_R4	Power		Positive supply voltage (3.3V) for the QCLK_R4 output. Supplied with 3.3V, 2.5V, or 1.8V.
37, 40	VDDO_R5	Power		Positive supply voltage (3.3V) for the QCLK_R5 output. Supplied with 3.3V, 2.5V, or 1.8V.
1	VDD_DPLL0	Power		Positive supply voltage (3.3V) for the DPLL-0 block
17	VDD_APLL	Power		Positive supply voltage (3.3V) for the APLL blocks
23	VDD_GPIO	Power		Positive supply voltage (3.3V) for the GPIO block

Table 1. Pin Descriptions^a

Pin	Name	Type ^b	Description
41	VDD_RFPLL	Power	Positive supply voltage (3.3V) for the RF-PLL block
44	VDD_RFVCO	Power	Positive supply voltage (3.3V) for the VCO in the RF-PLL block
63	VDD_DPLL1	Power	Positive supply voltage (3.3V) for the DPLL-1 block
66	VDD_DCO1	Power	Positive supply voltage (3.3V) for the VCO in the DPLL-1 block
67	VDD_INP	Power	Positive supply voltage (3.3V) for the CLK_0, CLK_1 inputs
72	VDD_SPI	Power	Positive supply voltage (3.3V) for the SPI interface and for digital blocks
83	VDD_OSC	Power	Positive supply voltage (3.3V) for the internal crystal oscillator (OSCI, OSCO)
86	VDD_XO	Power	Positive supply voltage (3.3V) for the XO_DPLL interface
Exposed Pad	GND	Power	Ground supply voltage (GND) and ground return path. Connect to board GND (0V).

a. For essential information on power supply filtering, see [Application Information](#).

b. PU (pull-up) and PD (pull-down) indicate internal input resistors (for values, see [Figure 131](#)).

Principles of Operation

Signal Flow

One and Two Frequency Domains

Applications generating the signals for one or two frequency domains do not require the use of the APLL-2. APLL-2 is available to be used as the high-frequency VCO in the SYS-DPLL (see [System DPLL \(SYS-DPLL\)](#)).

Table 2. Frequency Control Word (FCW) and Two Independent Frequency Domains

Signal Flow Description	Signal Flow Block Diagram
<p>One clock reference and one FCW (Frequency control word); two frequency-independent frequency domains</p> <ul style="list-style-type: none"> ▪ DPLL-0 (APLL-0 at 2450-2580MHz) locks to a synchronous Ethernet clock and generates the clocks for the first frequency domain (digital clock outputs 0 to 3) ▪ DPLL-1 (APLL-1 at 3932.16MHz) and the RF-PLL are the device frequency domain. The DCO in DPLL-1 is controlled by an external control word (FCW) through one of the serial interfaces ▪ The RF-PLL (2949.12MHz) locks to DPLL-1 and generates both device clock and SYSREF signals. ▪ DPLL-0 and DPLL-1 can run at different frequencies 	

Table 3. Synchronous Ethernet Frequency, IEEE1588 Phase Control Mode

Signal Flow	Description
<p>Synchronous Ethernet frequency and IEEE1588 Phase Control Mode</p> <ul style="list-style-type: none"> ▪ DPLL-0 (APLL-0 at 2450-2580MHz) locks to a synchronous Ethernet input clock and generates the clocks for the digital frequency domain (digital clock outputs 0 to 3) ▪ DPLL-1 (APLL-1 at 3932.16MHz) is frequency locked to DPLL-0 through the internal combo bus ▪ DPLL-1 is phase-controlled by an external control word (PCW) through a serial interface (S/I) ▪ The RF-PLL (2949.12MHz) locks to the DPLL-1 output and generates both device clock and SYSREF signals ▪ DPLL-0 (synchronous Ethernet) controls the DPLL-1 frequency while the external PCW applied to DPLL-1 allows for phase adjustments (IEEE1588 application) 	

Table 4. One Frequency Domain

Signal Flow	Description
<p>One frequency domain</p> <ul style="list-style-type: none"> Only DPLL-1 (APLL-1 at 3932.16MHz) is used and locks to a single reference input The RF-PLL (2949.12GHz) locks to the DPLL-1 output, forming a single frequency domain QCLK_R0-5 and QCLK_D2 to D3 output signals: the device clocks are generated by integer division from the RF-PLL. 	

Table 5. Source Frequency Mode through Combo Bus

Signal Flow	Description
<p>Source Frequency Mode through Combo bus</p> <ul style="list-style-type: none"> DPLL-0 (APLL-0 at 2450-2580MHz) is controlled by a FCW (frequency control word) Frequency information is copied from DPLL-0 to DPLL-1 DPLL-1 (APLL-1 at 3932.16MHz) is locked to DPLL-0 Outputs with clock signals from DPLL-0 and from the RF-PLL (through DPLL-1) are both synchronized to DPLL-0 	

Three Frequency Domains

Applications generating signals for three frequency domains require the use of at least one DPLL, APLL-0, APLL-1, the RF-PLL, and APLL-2. APLL-2 is used to generate frequencies not available from DPLL-0/APLL-0 (Ethernet) or from DPLL-1/APLL-1/RF-PLL (RF clocks). APLL-2 can lock to APLL-0 or APLL-1 and generate frequencies unrelated to other frequency domains. In these use cases, APLL-2 is unavailable to be used as the high-frequency PLL in the SYS-DPLL (see [System DPLL \(SYS-DPLL\)](#)).

Table 6. Three Independent Frequency Domains

Signal Flow Description	Signal Flow Block Diagram
<p>Two references, three frequency-independent frequency domains</p> <ul style="list-style-type: none"> Both DPLL-0 and DPLL-1 lock to different, independent input clocks. DPLL-0 (APLL-0 at 2450-2580MHz) generates the clocks for the first frequency domain (digital clock 1) APLL-2 generates the clocks for the second frequency domain (digital clock 0). DPLL-1 (APLL-1 at 3932.16MHz) and the RF-PLL are the device-clock domain locking to an input clock (e.g., a CPRI clock). The RF-PLL (2949.12MHz) locks to the DPLL-1/APLL-1 output and generates both device clock and SYSREF signals. DPLL-0/APLL-0 and DPLL-1/APLL-1 can run at different frequencies 	

Table 7. Source Frequency Mode

Signal Flow	Description
<p>Source Frequency Mode</p> <ul style="list-style-type: none"> DPLL-1 (APLL-1 at 3932.16MHz) is controlled by a FCW (frequency control word) Both the RF-PLL and the APLL are locked to DPLL-1 APLL and the RF-PLL generate different frequencies 	

System APLL (SYS-APLL)

The SYS-APLL generates internal system clocks of ~864MHz and ~108MHz, which are used by multiple internal digital function blocks. The SYS-APLL locks to the selected reference clock (XTAL oscillator OSCI/OSCO or XO_DPLL). The fractional feedback divider of the SYS-APLL must be configured to enable PLL to clock at $f_{VCO} \approx 864\text{MHz}$. Select the pre-divider of $\div 2$ to limit the SYS-APLL reference frequency $f_{REF,SYS-APLL}$ to 27MHz or less.

SYS-APLL can be powered down through bit 5 in register 0x011 to save current consumption. If the device is operated with both DPLL-0 and DPLL-1 in DCO mode and without using CLK_0 and CLK_1 as clock signal source for the DPLLs, SYS-APLL can be powered down.

Figure 3. System APLL (SYS-APLL) Diagram

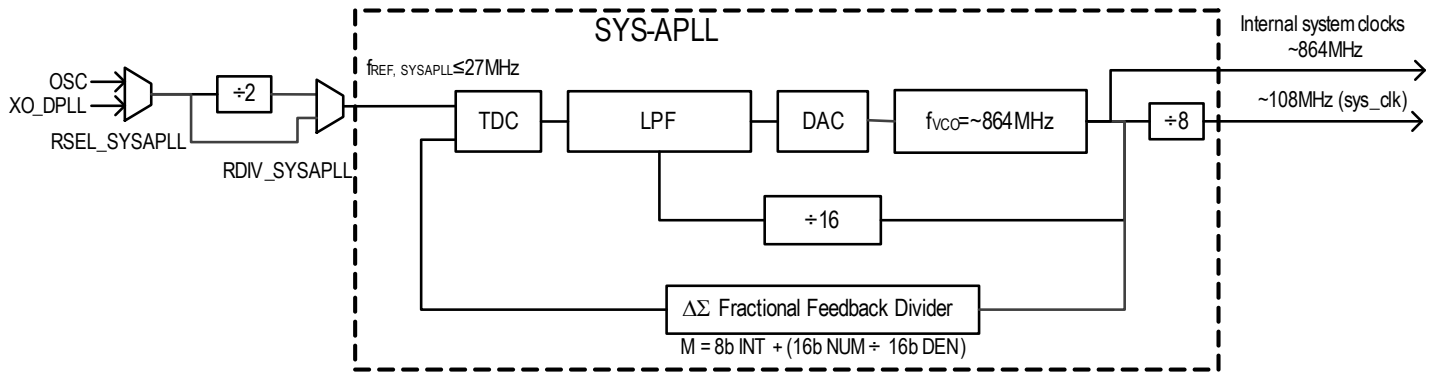

Table 8. SYS-APLL Frequency Divider^a

Block	Frequency	Description	Register
Selectable pre-divider	$f_{REF,SYS-APLL} < 27\text{MHz}$	Reference Pre-Divider for SYS-APLL	RDIV_SYSAPLL
SYS-APLL Fractional feedback divider (M)	$f_{VCO} (864\text{MHz}) = [M_INT + (M_NUM \div DEN)] \div f_{REF,SYS-APLL}$	8-bit Integer portion (M_INT)	M_INT_SA[7:0]
		16-bit Numerator (M_NUM)	M_NUM_SA[15:0]
		16-bit Denominator (M_DEN)	M_DEN_SA[15:0]

a. See “System APLL (SYS-APLL) Configuration”

System DPLL (SYS-DPLL)

The use of the SYS-DPLL is optional. When used, the purpose of the SYS-DPLL is to generate an internal frequency that is used for combo mode. The SYS-DPLL locks to an external oscillator on XO_DPLL (XO, TCXO, or OCXO) as a frequency reference for the device. By using the SYS-DPLL as a combo master with DPLL-0 or DPLL-1 as slave DPLLs, DPLL-0 and DPLL-1 will have the same frequency stability of the external oscillator locked to the SYS-DPLL. SYS-DPLL can only be used as a master for the combo bus.

When using SYS-DPLL, it is recommended to also have SYS-APLL locked the XO_DPLL so that the reference monitors have the same frequency stability of the external oscillator.

The SYS-DPLL implementation uses the APLL-2 as a high-speed oscillator. Therefore, APLL-2 is not available to be used as stand-alone synthesizer when the SYS-DPLL is used. When using the SYS-DPLL together with APLL-2, DPLL-0 must be also powered on.

Figure 4. System DPLL (SYS-DPLL) Diagram

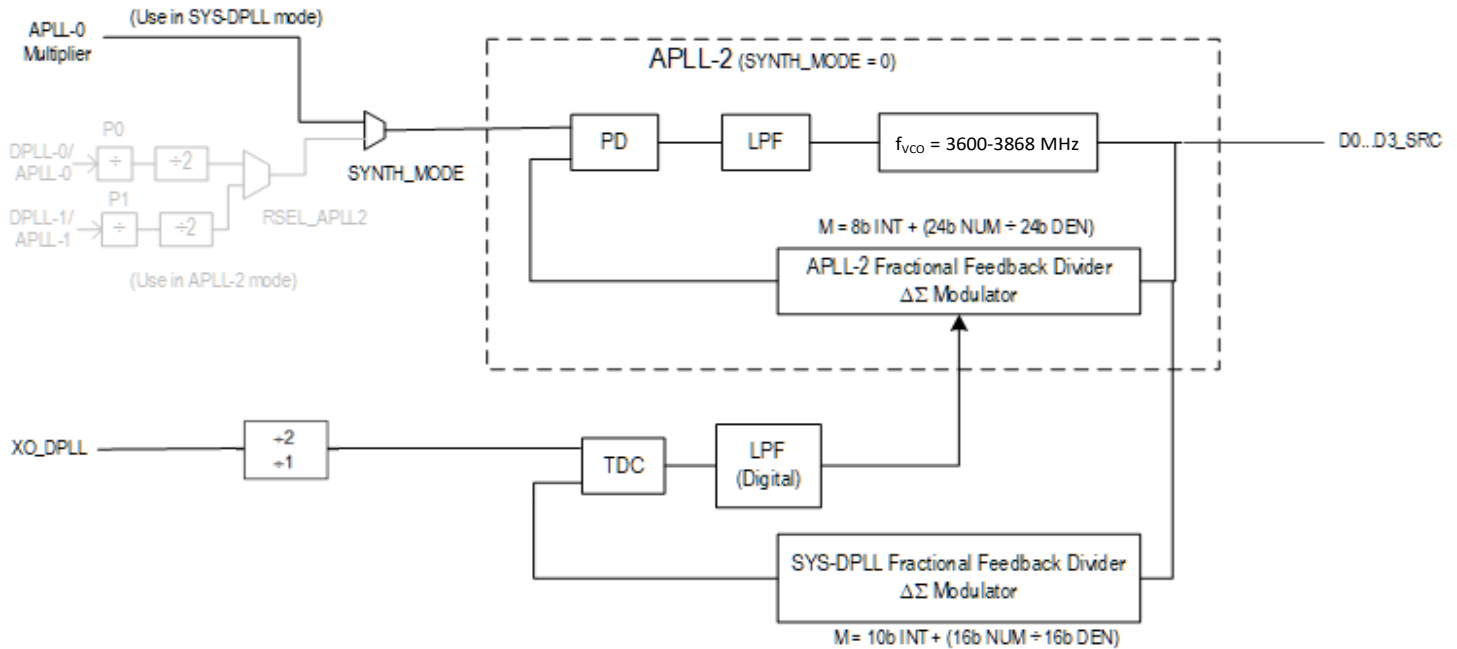

Table 9. SYS-DPLL Frequency Divider^a in SYS-DPLL Mode (SYNTH_MODE = 0)

Block	Frequency ^b	Description	Register
SYS-DPLL Fractional feedback divider (FFB)	$f_{VCO-2} = \frac{1}{2} \times f_{TCXO} \times [M_INT_SD + (M_NUM_SD \div M_DEN_SD)]$	10-bit Integer portion (M_INT)	M_INT_SD[9:0]
		16-bit Numerator (N_NUM)	M_NUM_SD[15:0]
		16-bit Denominator (M_DEN)	M_DEN_SD[15:0]
APLL-2 Fractional feedback divider	$f_{VCO_2} = 2 \times f_{XO} \times [M_INT + (M_NUM \div M_DEN)]$	8-bit Integer portion	M_INT_APLL2[7:0]
		24-bit Numerator	M_NUM_APLL2[23:0]
		24-bit Denominator	M_DEN_APLL2[23:0]

a. See [System DPLL \(SYS-DPLL\) Configuration](#) and [APLL-2](#).

b. f_{XO} is the OSCI/OSCO/XO_DPLL frequency.

Digital PLLs (DPLL-0, DPLL-1)

DPLL-0 Frequency Plan

Figure 5. Digital PLL 0 (DPLL-0) Diagram

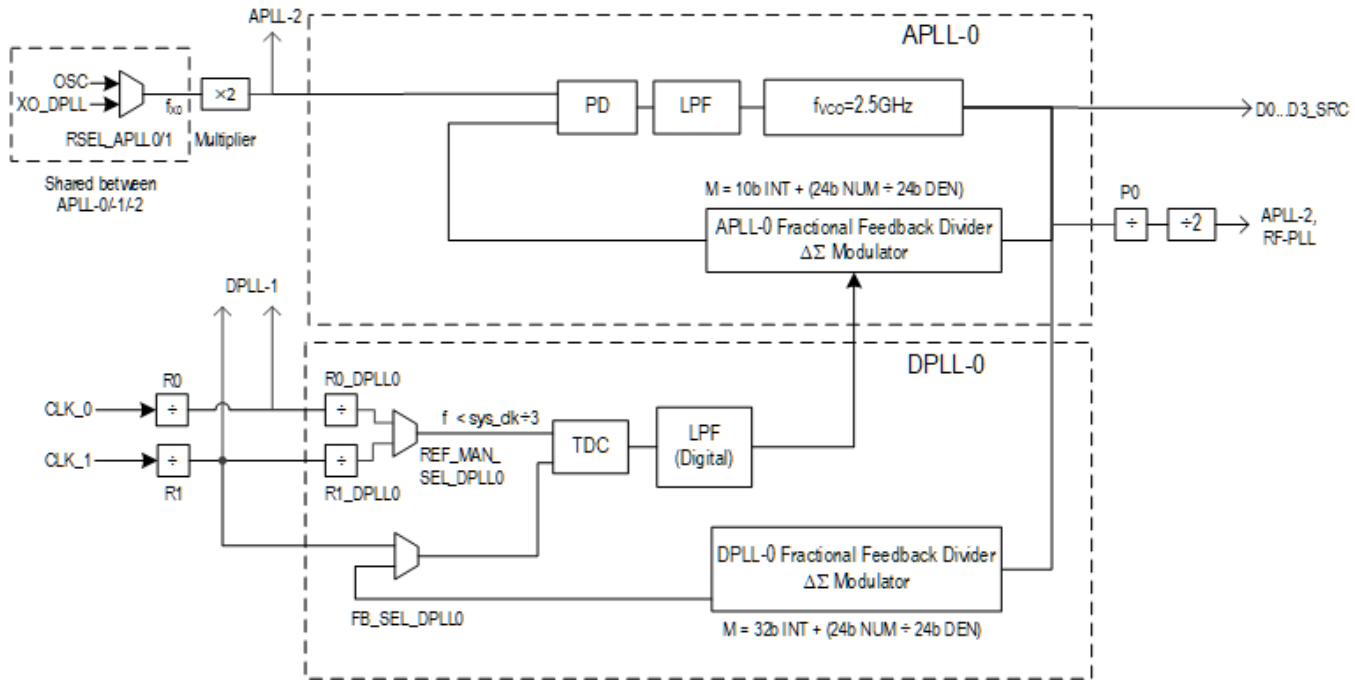

Table 10. DPLL-0 Frequency Divider^a

Block	Frequency ^b	Description	Register
APLL-0 Fractional feedback divider	$f_{VCO} = 2 \times f_{XO} \times [M_INT + (M_NUM \div M_DEN)]$	10-bit Integer portion	M_INT_APLL0[9:0]
		24-bit Numerator	M_NUM_APLL0[23:0]
		24-bit Denominator	M_DEN_APLL0[23:0]
Post divider P0	$f_{REF_APLL2} = f_{VCO} \div (2 \times P0)$ $f_{REF_RFPLL} = f_{VCO} \div (2 \times P0)$	APLL-0 output frequency divider	P0[6:0]
DPLL-0 Fractional feedback divider (M) for use with input CLK_0	$M = f_{VCO} \div (f_{CLK_0} \div (R0 \times R0_DPLL0)) = [M0_INT + (M0_NUM \div M0_DEN)]$	Input high frequency pre-divider (CLK_0)	R0[2:0]
		Input pre-divider (CLK_0)	R0_DPLL0[9:0]
		32-bit Integer portion	M0_INT_DPLL0[31:0]
		24-bit Numerator	M0_NUM_DPLL0[23:0]
		24-bit Denominator	M0_DEN_DPLL0[23:0]
DPLL-0 Fractional feedback divider (M) for use with input CLK_1	$M = f_{VCO} \div (f_{CLK_1} \div (R1 \times R1_DPLL0)) = [M1_INT + (M1_NUM \div M1_DEN)]$	Input high frequency pre-divider (CLK_1)	R1[2:0]
		Input pre-divider (CLK_1)	R1_DPLL0[9:0]
		32-bit Integer portion	M1_INT_DPLL0[31:0]
		24-bit Numerator	M1_NUM_DPLL0[23:0]
		24-bit Denominator	M1_DEN_DPLL0[23:0]

a. See DPLL-0 (APLL-0) Frequency Configuration and DPLL-0 Fractional Feedback Divider M1.

b. f_{XO} is the OSCI/OSCO/XO_DPLL frequency

In most uses cases, DPLL-0/APLL-0 drive the QCLK_Dn outputs directly for the generation of output frequencies such as 125MHz and 156.25MHz by integer division of the VCO frequency of 2450-2580MHz. The fractional feedback divider of APLL-0 must be configured to enable the PLL to clock at any frequency in the range $f_{VCO} = 2450\text{--}2580\text{MHz}$. In use cases where DPLL-0/APLL-0 drives the RF-PLL at its nominal VCO frequency of 2949.12MHz, DPLL-0/APLL-0 must be configured to a VCO frequency of 2457.6MHz. The frequency ratio of RF-PLL to APLL-0 must be integer in these use cases. [AC Characteristics](#) defines the operational frequency range for the VCOs in all APLLs and the RF-PLL.

DPLL-1 Frequency Plan

Figure 6. Digital PLL 1 (DPLL-1) Diagram

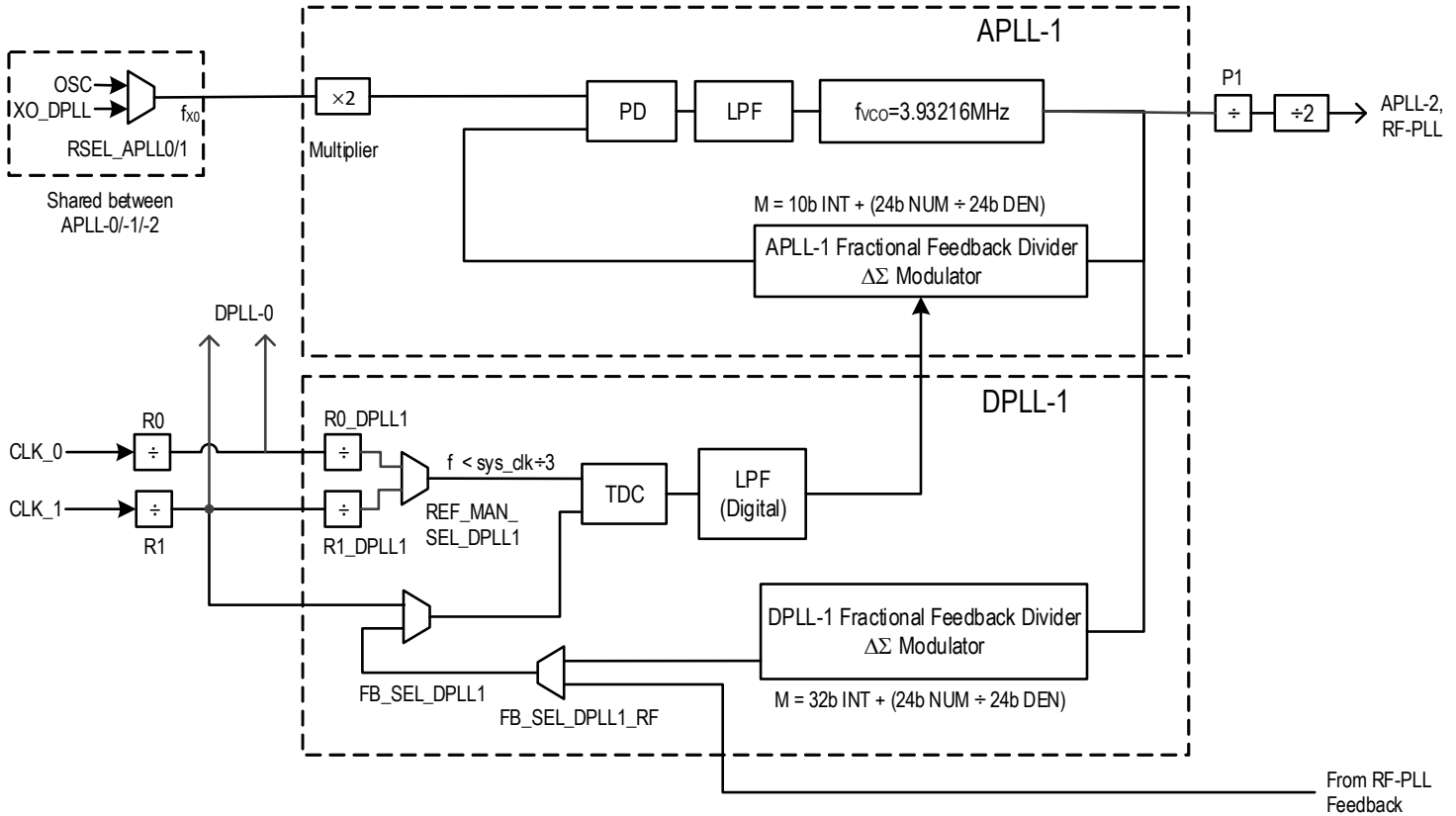

Table 11. DPLL-1 Frequency Divider^a

Block	Frequency ^b	Description	Register
APLL-1 Fractional feedback divider	$f_{VCO} = 2 \times f_{XO} \times [M_INT + (M_NUM \div M_DEN)]$	10-bit Integer portion	M_INT_APLL1[9:0]
		24-bit Numerator	M_NUM_APLL1[23:0]
		24-bit Denominator	M_DEN_APLL1[23:0]
Post divider	$f_{REF_APLL2} = f_{VCO} \div (2 \times P1)$ $f_{REF_RFPLL} = f_{VCO} \div (2 \times P1)$	APLL-1 output frequency divider	P1[6:0]
DPLL-1 Fractional feedback divider (M) for use with input CLK_0	$M = f_{VCO} \div (f_{CLK_0} \div (R0 \times R0_DPLL1)) = [M0_INT + (M0_NUM \div M0_DEN)]$	Input high frequency pre-divider (CLK_0)	R0[2:0]
		Input pre-divider (CLK_0)	R0_DPLL1[9:0]
		32-bit Integer portion	M0_INT_DPLL1[31:0]
		24-bit Numerator	M0_NUM_DPLL1[23:0]
		24-bit Denominator	M0_DEN_DPLL1[23:0]

Table 11. DPLL-1 Frequency Divider^a

Block	Frequency ^b	Description	Register
DPLL-1 Fractional feedback divider (M) for use with input CLK_1	$M = f_{VCO} \div (f_{CLK_1} \div (R1 \times R1_DPLL1)) = [M1_INT + (M1_NUM \div M0_DEN)]$	Input high frequency pre-divider (CLK_1)	R1[2:0]
		Input pre-divider (CLK_1)	R1_DPLL1[9:0]
		32 bit Integer portion	M1_INT_DPLL1[31:0]
		24 bit Numerator	M1_NUM_DPLL1[23:0]
		24 bit Denominator	M1_DEN_DPLL1[23:0]

a. See “DPLL-1 (APLL-1) Frequency Configuration” and See “DPLL-1 Fractional Feedback Divider M1”

b. f_{x0} is the OSCI/OSCO/XO_DPLL frequency.

DPLL-0/DPLL-1 Operation States

DPLL-0 and DPLL-1 support the same modes of operation. APLL-0 and APLL-1 are part of the loop for DPLL-0 and DPLL-1, respectively. The VCO frequency for the APLL-0 is 2450-2580MHz and VCO frequency for the APLL-1 is 3932.16MHz. Both DPLLs have five states of operation as follows:

- Locked/Normal state – The output clock is synchronized to an input reference. In this mode, the DPLL is tracking the selected reference with normal locking bandwidth and damping factor. The phase and frequency offset of the DPLL output track those of the DPLL selected input clock.
- Holdover state – The DPLL has lost its reference with no other qualified references available and uses the stored data acquired in Locked mode to control its output clock. After the DPLL enters holdover, the accuracy of its output depends on the master clock oscillator (OSCI/OSCO or XO_DPLL).
- Free-run state – The DPLL has never locked to any input reference and the accuracy of its output is dependent on the master clock oscillator (OSCI/OSCO or XO_DPLL).
- Lock acquisition – At least one qualified reference is present prior to reaching the locked state. The DPLL will be tracking the selected reference at acquisition bandwidth and damping factor.
- Lock recovery – The DPLL is tracking the selected reference at acquisition bandwidth and damping factor.

Register bits [DPLL_STATE_DPLL0\[2:0\]](#) and [DPLL_STATE_DPLL1\[2:0\]](#) can be used to force the DPLL-0 and DPLL-1, respectively, to any of the five DPLL states described above. The default value set the DPLLs in free run. When these bits are set to program the DPLL in lock acquisition, or lock recovery, or Locked/Normal state, and if the selected reference is disqualified, then the DPLL will automatically go into holdover if the [FAIL_HOLD_DPLL0/FAIL_HOLD_DPLL1](#) bit is asserted. Otherwise, the DPLL will stay at the programmed state (mode).

If the bits [DPLL_STATE_DPLL0\[2:0\]](#) and [DPLL_STATE_DPLL1\[2:0\]](#) are set to 0b101, then the DPLLs are programmed to use an internal automatic state machine. The DPLL state machine diagram is shown in [Figure 7](#).

Figure 7. DPLL State Machine Diagram

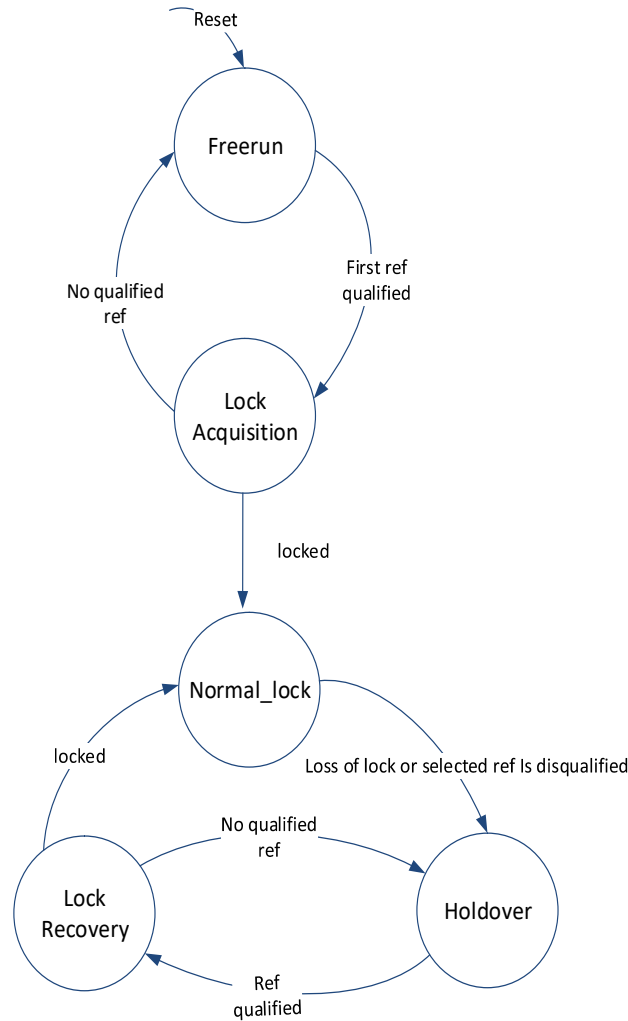

As showed in [Figure 7](#), the DPLL state changes are as follows:

1. After reset, the DPLL enters Free-Run State.
2. After an input clock is qualified and it is selected, it enters the Lock Acquisition State.
3. If the DPLL selected input clock is disqualified AND no qualified input clock is available, it goes back to Free-run State.
4. If the DPLL locks to the selected input clock, it enters Normal_lock State.
5. The DPLL selected input clock is disqualified AND No qualified input clock is available, it enters Holdover State.
6. If a qualified input clock is now available, it enters lock recovery State.
7. If the DPLL selected input clock is disqualified AND no qualified input clock is available, it goes back to Holdover State.
8. If the DPLL locks to the selected input clock, it enters Normal_lock State.

In state changes 6 above, the DPLL switches to another qualified clock because of one of the following:

- The selected input clock was disqualified and another qualified input clock is available
- The device is set to revertive mode and a qualified input clock with a higher priority is available.

While in the Normal_lock state, if the input clock exceeds the programmed Lock Threshold, then the DPLL will enter the Holdover state.

DPLL Loop Bandwidth

The bandwidth (BW) of the DPLL is precise and static and independent on the clock frequency. The bandwidth of the DPLL does not change with the frequency plan. The bandwidth is programmable from 1mHz to approximately 6kHz.

There are two register fields associated with the bandwidth settings: [NORMAL_BW_SHIFT_DPLL0\[4:0\]](#)/[NORMAL_BW_SHIFT_DPLL1\[4:0\]](#) and [NORMAL_BW_MULT_DPLL0\[2:0\]](#)/[NORMAL_BW_MULT_DPLL1\[2:0\]](#). To calculate the BW, the following equation is used:

$$BW = (K_{TDC} \times K_{PEC} \times K_P) / 2\pi$$

Where:

$$K_{TDC} = 1 / T_{DC_STEP}$$

$$T_{DC_STEP} = T_{SYSAPLL_VCO} / 62 = 18.67ps$$

$$K_{PEC} = 2 \times 10^7$$

$$K_P = (NORMAL_BW_SHIFT_DPLL0[4:0] / 4) \times 2^{(NORMAL_BW_MULT_DPLL0[2:0]-53)}$$

Holdover State

In holdover state, the DPLL has lost its reference and uses the stored data acquired in Locked mode to control its output clock. The initial frequency offset is 1.1×10^{-7} ppb. After the DPLL enters holdover, the accuracy of its output depends on the master clock oscillator (connected to OSCI/OSCO or XO_DPLL/nXO_DPLL pins). If the SYS-DPLL is enabled, then it is assumed that the SYS-DPLL is locked to the master clock oscillator that is connected to XO_DPLL/nXO_DPLL pins, and therefore the holdover is based on this master clock oscillator. If SYS-DPLL is not enabled, then holdover is based on the master clock oscillator that is connected to the OSCI/OSCO pins.

The 8V19N850 supports the following holdover states:

- Instantaneous Holdover
- History Instantaneous Holdover
- History Averaged Holdover
- Manual Holdover

The holdover states can be set by programming bits [HOLDOVER_MODE_DPLL0\[1:0\]](#) and [HOLDOVER_MODE_DPLL1\[1:0\]](#) for DPLL-0 and DPLL-1, respectively.

Instantaneous Holdover

If DPLL-0/-1 is set to operate in Instantaneous Holdover, then the DPLL freezes at the operating frequency when it enters holdover state. The initial frequency offset is better than is 1.1×10^{-7} ppb assuming that there is no in-band jitter/wander at the input just before entering holdover state.

History Instantaneous Holdover

The 8V19N850 implements a history of the instantaneous holdover values. Previously stored instantaneous holdover value can be retrieved. The rate at which the holdover registers are stored is programmable. It can be programmed in steps of 1 second between 1 and 64 s by programming register bits, [HOLDOVER_HISTORY_DPLL0\[5:0\]](#) and [HOLDOVER_MODE_DPLL1\[1:0\]](#) for DPLL-0 and DPLL-1 respectively. The default value is 1s.

History Averaged Holdover

When a DPLL is set to history averaged holdover state, the holdover value is post filtered. The filter bandwidth is programmable from approximately 0.12mHz to 0.5Hz. When a DPLL enters the history averaged holdover state, the holdover register value is restored into the integrator inside that DPLL. The rate at which the holdover registers are stored is programmable between 1 and 64 s in steps of 1 s by programming register bits [HOLDOVER_HISTORY_DPLL0\[5:0\]](#) and [HOLDOVER_HISTORY_DPLL1\[5:0\]](#) for DPLL-0 and DPLL-1, respectively. The default value is 1s.

The holdover filter bandwidth value is programmed by setting [HOLDOVER_BW_SHIFT_DPLL0\[4:0\]](#) / [HOLDOVER_BW_SHIFT_DPLL1\[4:0\]](#) (for DPLL-0) and [HOLDOVER_MULT_DPLL1\[2:0\]](#) / [HOLDOVER_MULT_DPLL1\[2:0\]](#) (for DPLL-1) as follows:

Holdover filter bandwidth = $coe \times f / (2\pi)$ where

- $coe = 2^{-(33-HOLDOVER_BW_SHIFT_DPLLn)} \times HOLDOVER_MULT_DPLLn / 4$ (n = 0 for DPLL-0, n = 1 for DPLL-1)
- f is the update rate of both DPLLs (600kHz).

If coe is zero then the filter is bypassed.

Manual Holdover

In manual holdover, the frequency offset is set by the DPLL manual holdover value register bits [HOLDOVER_VALUE_DPLL0\[41:0\]](#) and [HOLDOVER_VALUE_DPLL1\[41:0\]](#) for DPLL-0 and DPLL-1, respectively.

Forced into Holdover

The DPLL can also be forced into the holdover state. If it is forced into holdover state, then the DPLL will stay in holdover even if there are valid references available for the DPLL to lock to. Register bits [DPLL_STATE_DPLL0\[2:0\]](#) and [DPLL_STATE_DPLL1\[2:0\]](#) can be used to set the DPLL-0 and DPLL-1, respectively, to holdover.

Pull-in/Hold-in

Both DPLLs support independently a pull-in range of $\pm 4.6 \times 10^{-6}$, $\pm 12 \times 10^{-6}$, $\pm 20 \times 10^{-6}$, $\pm 32 \times 10^{-6}$, $\pm 52 \times 10^{-6}$, $\pm 83 \times 10^{-6}$, $\pm 131 \times 10^{-6}$, and $\pm 147 \times 10^{-6}$.

Free-Run Frequency Accuracy

The free-run accuracy is dependent on the oscillator, both DPLLs support free run accuracy based on the local oscillator.

Phase Slope Limiting (PSL)

Each DPLL supports independent phase slope limiting that is programmable through registers. Each DPLL allows the phase slope limiting to be set such as 1ns/s, 5ns/s, 10 ns/s, 885ns/s, 7.5 μ s/s, or 61 μ s/s to meet different applications. It can also be bypassed.

IEEE 1588 Modes of operation

Write Frequency Mode

The DCO circuits from DPLL-0 and DPLL-1 can be controlled by a digital word that can represent phase offset and frequency offset. Bits [WRITE_FREQUENCY_EN_DPLL0](#) and [WRITE_FREQUENCY_EN_DPLL1](#) can be used to program DPLL-0 and DPLL-1 respectively in the write frequency mode.

[Figure 8](#) shows the DCO being controlled by writing a frequency control word into the DCO. The Frequency Control Word (FCW) is used to adjust the frequency output of the DCO, the phase detector and loop filter are bypassed. In this case, the filtering is done by an external processor that will be controlling the DCO. The frequency offset written into the register is passed on directly to the output clocks. The FCW ([WRITE_FREQUENCY_DPLL0\[41:0\]](#)/[WRITE_FREQUENCY_DPLL1\[41:0\]](#)) is a 42-bit 2's-complement value, the total range is ± 244 ppm of the nominal DCO frequency, and the DCO programming resolution is 1.1×10^{-7} ppb.

Figure 8. Write Frequency Mode

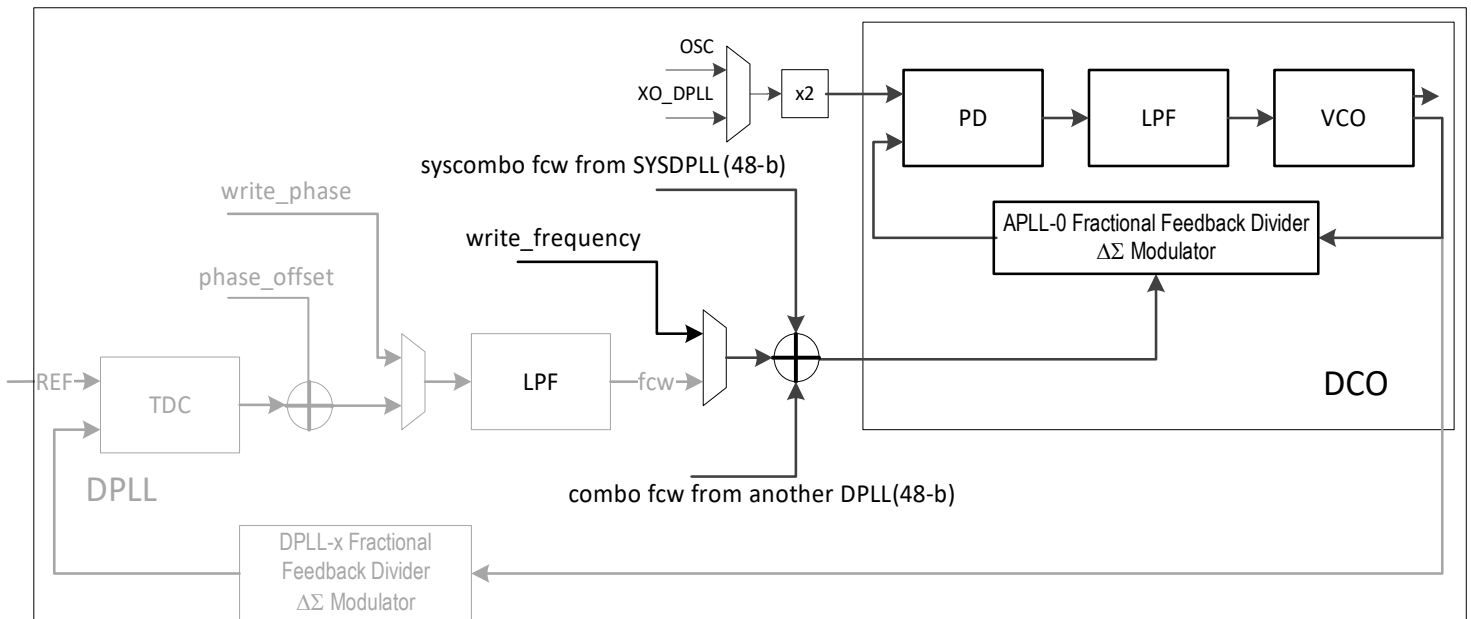

In write frequency mode, APLL VCO is tuned by the FCW as follows:

$$f_{VCO} = f_{XO} \times N \times (1+FCW)$$

Where:

f_{VCO} is the APLL VCO frequency.

f_{XO} is the OSCI/OSCO/XO_DPLL frequency which is fixed.

N is the nominal APLL feedback divider ratio.

FCW is the tuning word which is 42-bit 2's complement and LSB is 2^{-53} .

FCW is calculated as follows:

$$FCW = FFO \times 10^{-6} \times 2^{53}$$

and

FFO is the target fractional frequency in ppm.

As an example, change the output frequency by 10ppb (10×10^{-3} ppm) on DPLL-1:

Control word (in decimal): $10 \times 10^{-3} \times 10^{-6} \times 2^{53} = 90,071,992.547409020$

Convert 90,071,992 into Hex (0x55E63B8) to write into register ([WRITE_FREQUENCY_DPLL0\[41:0\]](#)/[WRITE_FREQUENCY_DPLL1\[41:0\]](#)).

Write Phase Mode

Each DCO of DPLL-0 and DPLL-1 can be controlled by a digital word that can represent phase offset, and use the hardware loop filter to filter it per [Figure 9](#).

Bits [WRITE_PHASE_EN_DPLL0](#) and [WRITE_PHASE_EN_DPLL1](#) can be used to program DPLL-0 and DPLL-1 respectively in the write phase mode.

Figure 9. Write Phase Mode

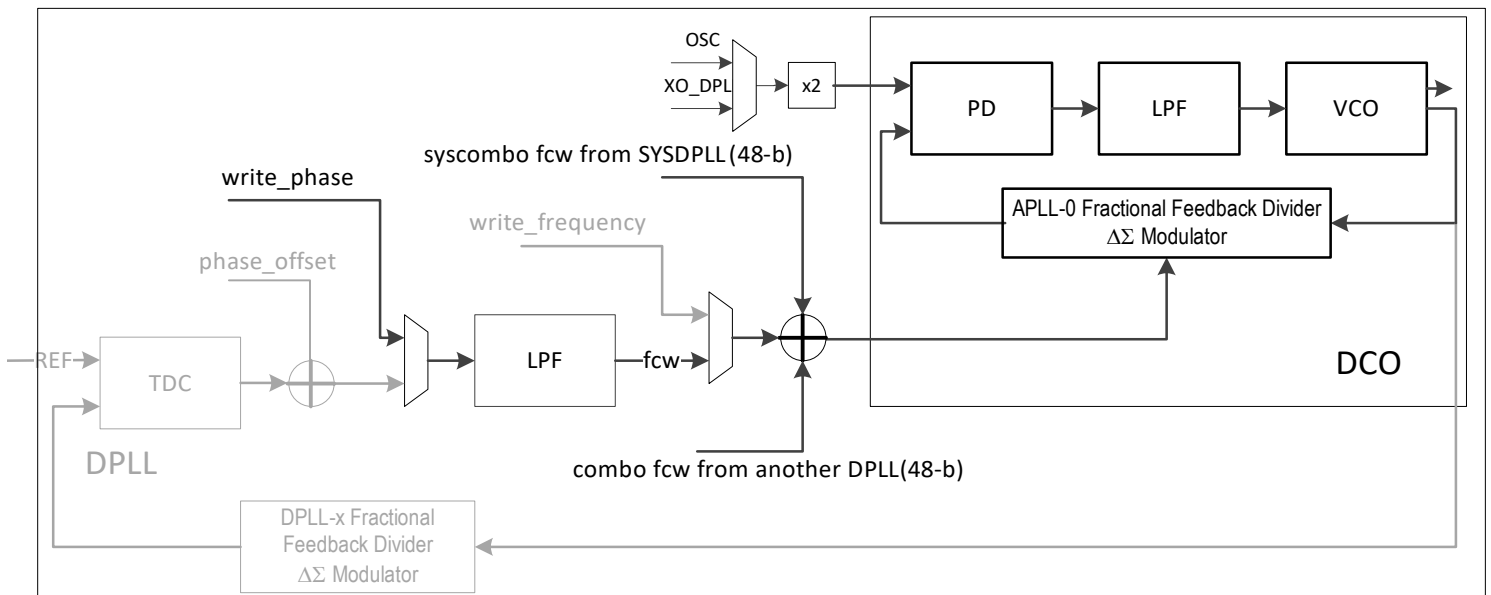

[Figure 9](#) shows the DCO being controlled by writing a phase offset word into the DCO, then an external processor directly controls the DCO phase through the Microport interface with hardware controlled bandwidth (e.g., 0.1Hz per G.8273.2) and phase slope limiting.

The phase control word (PCW) can be written into [WRITE_PHASE_DPLL0\[31:0\]](#)/[WRITE_PHASE_DPLL1\[31:0\]](#) bits for DPLL-0/1.

The PCW is a 32-bit 2's-complement value. The resolution of the PCW is 1 TDC step. The TDC step is $T_{SYSAPLL_VCO} / 62$ and the range is $\pm(2147483647 \times (\text{TDC step}))$. For example, if the system DPLL VCO frequency is 864MHz, then the TDC step is 18.6678614097969ps, and the range is ± 40.0889271020012 ms.

The PCW applied to LPF (Low Pass Filter) is equivalent to applying a phase error measured by the on-chip TDC (Phase Detector) applied to LPF when the DPLL is operating in closed loop. The update rate needs to be at least 60 times of the loop filter bandwidth; as an example, for 0.1Hz, the update rate should be greater than 6Hz.

To assist in the above, there is an optional timer associated with the PCW and the FCW. This allows a phase/frequency control word to be applied for a limited period of time after which it will automatically go into holdover, and therefore it will avoid the DCO to continue to apply the phase/frequency adjustment indefinitely until it reaches its tuning range limits. The timer value is a 16-bit integer (see [WRITE_TIMER_DPLL0\[15:0\]/WRITE_TIMER_DPLL1\[15:0\]](#)), it can be set in multiples of 125 μ s.

Combo Mode

The 8V19N850 supports DPLL combo mode. Both DPLL-0 or DPLL-1 can be programmed to either the combo master (the generator of the frequency control word (FCW), or the combo slave (the receiver of the FCW).

For example, if [COMBO_MODE_EN_DPLL0](#) is set to zero, and [COMBO_MODE_EN_DPLL1](#) is set to 1, then DPLL-0 is the combo master and DPLL-1 is the combo slave. In this example, DPLL-0 can be locked to an input reference clock, such as a Synchronous Ethernet clock, which is a regular PLL channel and can generate output clocks of different frequencies that track the Synchronous Ethernet input reference clock. And the DPLL-1 can be used as a DCO and it will be controlled externally, as an example by an IEEE 1588 clock recovery servo algorithm running in an external processor.

In this example, the IEEE 1588 timestamps can be used to calculate the phase offset between the IEEE 1588 master's 1PPS pulse and the IEEE 1588 slave's 1PPS pulse and then align the two pulses by moving the slave's 1PPS pulse in phase. The phase offset between the IEEE 1588 master's 1PPS pulse and the IEEE 1588 slave's 1PPS pulse can be written into the Phase Control Word into DPLL-1 channel over the serial port to correct the phase, as described in the Write-Phase Mode section.

[Figure 10](#) shows a functional block diagram of the combo mode.

Figure 10. Combo Mode Functional Block Diagram

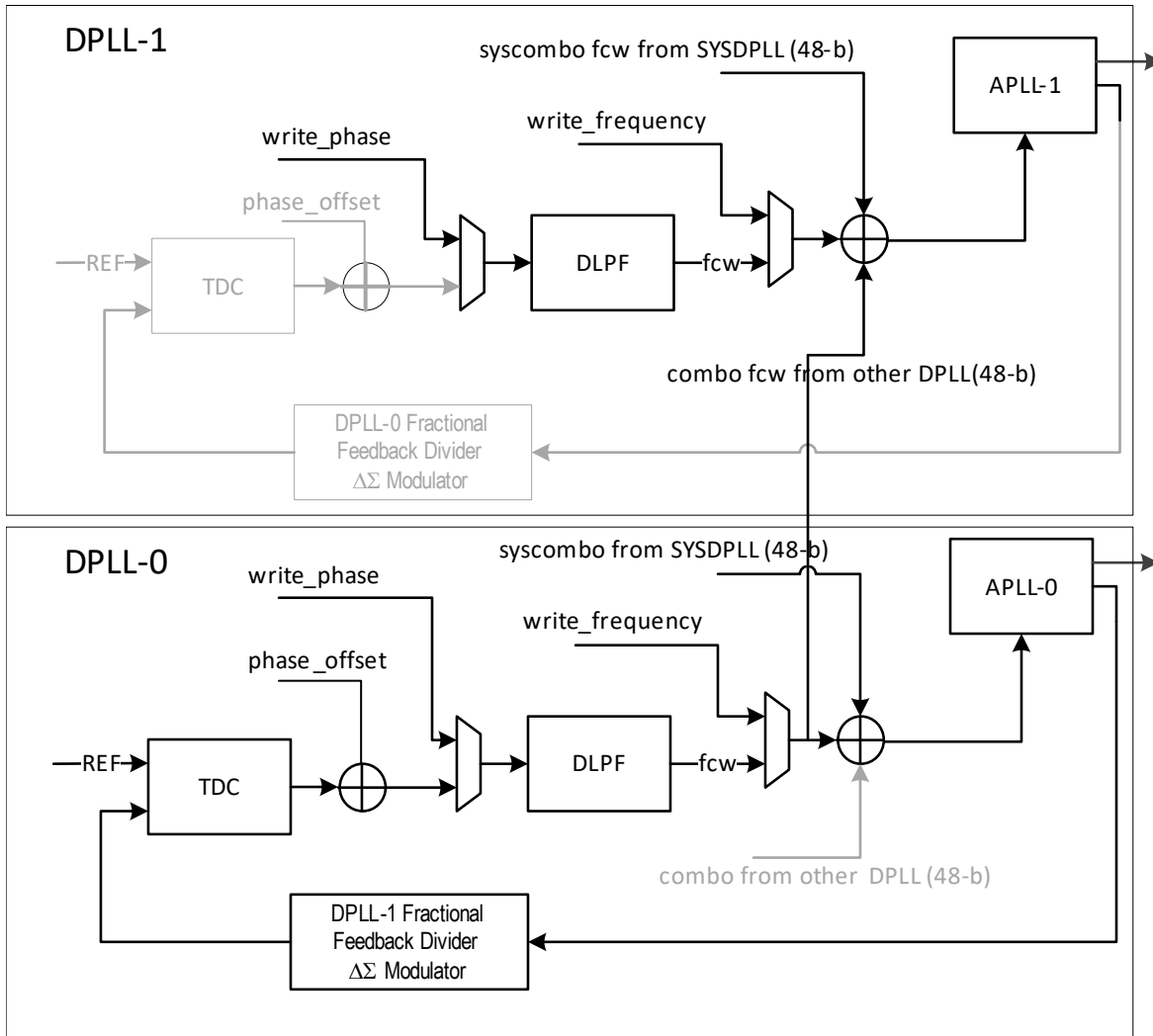

The phase and frequency offsets between the combo master and slave are available for software to read at all times. The frequency information can be temporarily placed on hold (i.e., to ride out a phase transient).

Phase Adjustment through DPLL

The 8V19N850 supports phase adjustments to be done through the DPLL-0 and DPLL-1. Figure 11 shows a functional block DPLL-0/-1.

Figure 11. DPLL-0/-1 Functional Block Diagram

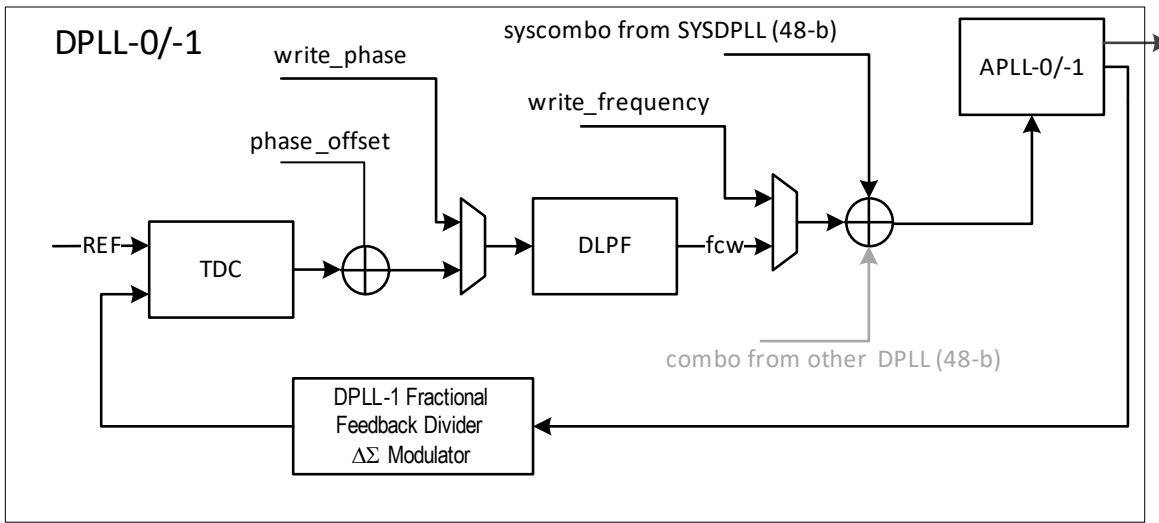

When DPLL-0/-1 is locked to a clock, the phase of the output clock can be adjusted using a Phase Offset Word (phase_offset in Figure 11).

The phase offset word (POW) is a 36-bit 2's-complement value. It can be written into PHASE_OFFSET_DPLL0[35:0]/PHASE_OFFSET_DPLL1[35:0] bits for DPLL-0/1. The resolution of the POW is 1 TDC step. The TDC step is $T_{SYSAPLL_VCO} / 62$ and the range is $\pm(2147483647 \times (T_{DC_STEP}))$. For example, if the system DPLL VCO frequency is 864MHz, then the TDC step is 18.6678614097969ps, and the range is ± 40.0889271020012 ms.

Input Clock Qualification and Reference Selection

The input clock qualification is based on the reference monitoring (for more information, see Input Clock Quality Monitoring). The device has three reference selection modes set by the REF_SEL_MODE_DPLL0/1 bits as follows:

- Pin selection mode through selection pins (assigned GPIO pins)
- Manual selection mode through register bits set through SPI/I3C interface.
- Automatic input clock selection mode

There is an independent reference selection process for each DPLL. The mode for each DPLL can be set as shown in Table 12

Table 12. REF_SEL_MODE_DPLL0/1 Bits to Select the DPLL Mode

REF_SEL_MODE_DPLL0[1:0], REF_SEL_MODE_DPLL1[1:0]	Description
00	Pin Selection Mode through assigned GPIO pins
01	Manual selection Mode through register bits set through SPI/I3C interface
10	Automatic selection mode
11	Reserved

Pin Selection Mode

In this mode, if REF_SEL_MODE_DPLL0/1[1:0] are set to 00, then both DPLLs lock to the input reference selected by GPIOs

Table 13. Reference Input Selection by Pins for DPLL-0

Selection by GPIO CLKnSEL0	Description
0	CLK_0
1	CLK_1

Table 14. Reference Input Selection by Pins for DPLL-1

Selection by GPIO CLKnSEL1	Description
0	CLK_0
1	CLK_1

The input clock monitoring will continue to monitor the input clock, and if the selected input reference fails and the bit fail_hold is set, then the DPLL will enter holdover automatically. The DPLL will automatically recover from holdover (or free-run) when the reference becomes valid or if another valid reference is selected by GPIO (CLKnSEL1/0) pins. If the selected reference is invalid and no other valid reference gets selected by the GPIO (CLKnSEL1/0) pins, then the DPLL will continue in holdover state.

If fail_hold bit is not set, then the DPLL continues to lock to the reference clock selected by GPIO (CLKnSEL1/0) pins, even if that particular reference is no longer valid. The DPLL will continue to track the clock selected by GPIO (CLKnSEL1/0) pins and will do a reference switching once the GPIO (CLKnSEL1/0) pins select another clock input. If the selected reference is invalid and no other valid reference gets selected by the GPIO (CLKnSEL1/0) pins, then the DPLL will continue to track to the invalid reference.

In this mode, when doing a reference switching between two inputs, they must be at the same frequency. If they have different frequencies, then the input dividers can be used to divide down the frequency to a common frequency to the internal input of the DPLL.

Manual Selection Mode

In this mode, each DPLL locks to the input reference selected by ref_man_sel_dpll0/1 bit in the appropriated register per [Table 15](#).

Table 15. Manual Reference Input Selection by Register Bits

ref_man_sel_dpll0/1	Description
0	CLK_0
1	CLK_1

In this mode, each DPLL has its own set of registers and therefore each DPLL can select a different input based on the ref_man_sel_dpll0/1 selection bits for each DPLL. The automatic state machine is disabled and the input clock monitoring does not affect the input clock selection.

In this mode, the input clock selection is done by setting the proper bits in the control registers related to each DPLL, the input clock monitoring will continue to monitor the input clock (see [Input Clock Quality Monitoring](#)), and if the selected input reference fails, then the DPLL will enter holdover automatically. The DPLL will automatically recover from holdover (or free-run) when the reference becomes valid or if another valid reference is selected by the ref_man_sel_dpll0/1 register bit.

In this mode, if the selected reference is invalid and no other valid reference gets selected by the ref_man_sel_dpll0/1 register bit, then the DPLL will enter holdover state.

Automatic Input Clock Selection Mode

If automatic input clock selection is used, then an internal automatic state machine will automatically do reference switching and the input clock selection is determined by the input clock being qualified. An input is considered qualified based on being valid by the clock monitor (see [Input Clock Quality Monitoring](#)), the priority of each input clock, and the input clock configuration.

If bits `DIS_CLK0_BY_PIN` and `DIS_CLK1_BY_PIN` are set to 1, then a GPIO (see [Input Disqualification by GPIO pins](#)) can be used to disable `CLK_0` and `CLK_1` to be used by DPLL-O and DPLL-1.

If bits `DIS_CLK0_BY_PIN` and `DIS_CLK1_BY_PIN` are set to 0, then bits `DIS_CLK0` and `DIS_CLK1` can be used to disable `CLK_0` and `CLK_1` to be used by DPLL-O and DPLL-1. If the input is enabled (`DIS_CLK0` or `DIS_CLK1` is set to 0) and the reference monitors declare that input valid, then that input is qualified to be used by the DPLLs. If the input is disabled (`DIS_CLK0` or `DIS_CLK1` is set to 1), and even though the reference monitors declare that input valid, then that input is disqualified to be used by the DPLLs.

Within all the qualified inputs, the one with the highest priority is selected by the DPLL. The input clock priority is set by setting bits `REF_PRIORITY_DPLL0` and `REF_PRIORITY_DPLL1` for DPLL-0 and DPLL-1 respectively.

Reference Switching

Automatic reference Switching

In Automatic Locked Mode, the input clock selection must be determined by the input clock being qualified. An input is considered qualified based on being valid by the clock monitor (see [Input Clock Quality Monitoring](#)), the priority of each input clock, and the input clock configuration.

The input clock must be declared valid depending on the results of input clock quality monitoring (refer to [Input Clock Quality Monitoring](#)). Within all the valid input clocks (the ones that do not have fail alarm(s)), the one with the highest priority must be selected.

The priority must be set by setting bits `REF_PRIORITY_DPLL0` and `REF_PRIORITY_DPLL1` for DPLL-0 and DPLL-1 respectively. The input clock must also be configured to be valid or invalid by register configuration. If hitless reference switching is enabled, then the output phase change is below 1ns when the device performs a reference switching between two reference inputs that are integer multiple ratios of each other, and are divided down to the least common frequency through the pre-dividers.

Hitless Reference Switching

Hitless reference switching is supported for all frequency clocks.

The Hitless Switching (HS) circuit eliminates phase transients on the output clock that may occur during reference switching or the recovery from Holdover state to Locked state. On recovery from holdover state or when switching to another reference input, the HS circuit measures the phase delay between the current phase (feedback signal) and the phase of the newly selected reference input. This delay value is used by the PLL to minimize the phase transient it experiences when it switches to another reference input or recovers from holdover state.

An HS event must be triggered if either of the following conditions occurs:

- DPLLs selected input clock switches to a different reference
- DPLLs exits from holdover state

For the two conditions above, the phase transients on the DPLLs output are minimized < 1ns with Hitless Switching (HS) enabled.

If HS is disabled, then there may be a phase shift on the DPLLs output, as the DPLLs output tracks back to 0 degree phase offset with respect to the DPLLs selected input clock.

When HS is enabled, there could be cases where it is needed to clear the phase (as an example, the DPLL goes into holdover for a long period of time, and therefore it is better to not do a hitless reference switching when it recovers from a long-term holdover state). In this case a bit, `HS_CLR`, can be set to clear the delay value (TIE). In general, `HS_CLK` should not be exercised when holdover state is entered for short time periods. The speed of the phase alignment correction is limited by the PSL setting.

Revertive and Non-Revertive Reference Switching

The 8V19N850 supports revertive and non-revertive reference switching. Revertive switching can be disabled by register bit.

Input Clock Quality Monitoring

The quality of all the input reference clocks is always monitored individually (excluding the OSCI/OSCO or XO_DPLL input), 8V19N850 has 3 reference monitors as follows:

- Short-term monitor (this monitor can be used for LOS (loss of signal) detector)
- Medium-term monitor (this monitor can be used for activity)
- Long-term monitor (this monitor can be used for detecting frequency offset)

Each input clock can be individually configured for monitoring, and each monitor type can be masked. The active reference is also monitored to ensure that it is still a valid reference. If an input clock fails, then an alarm will be generated, an input clock with an alarm condition cannot be used for an input reference if the alarm is not masked. The reference monitor is based on reference clock of the system APLL (OSCI/OSCO or XO_DPLL). A TCXO/OCXO must be used for better accuracy.

Short-Term Monitor

Each input clock reference is monitored using the short-term monitor. The short-term monitor can be used to detect loss of signal. It supports input clock frequencies equal to or above 1MHz.

The short-term monitor takes the input clock from after the input high frequency pre-divider (maximum frequency is 36MHz) and before the input pre-divider. The period of this frequency is used to create a window to compare whether or not the input clock is within a certain frequency. The window size is programmable.

- Window size = T_{REF} (if DIV_RATIO_ST is set to 0 or to 1)
- Window size = $(DIV_RATIO_ST+2) \times T_{REF}$
- T_{REF} = period of the input reference clock, after high frequency pre-divider

Where DIV_RATIO_ST is programmable by using bits [DIV_RATIO_ST_REF_MON0\[5:0\]](#) and [DIV_RATIO_ST_REF_MON1\[5:0\]](#) for CLK_0 and CLK_1, respectively.

A counter that is part of the short-term monitor is used to count the number of system clocks (SYS_CLK that is approximately 108MHz) within the window.

The nominal counter value is calculated as follows:

- $NOMINAL_NUM_ST = f_{SYS_CLK} / f_{REF}$ (if DIV_RATIO_ST is set to 0 or to 1)
- $NOMINAL_NUM_ST = f_{SYS_CLK} / (f_{REF} / (DIV_RATIO_ST + 2))$
- $f_{SYS_CLK} = \sim 108MHz$
- f_{REF} = frequency of the input reference clock, after high frequency pre-divider

The NOMINAL_NUM_ST value is then set into [NOMINAL_NUM_ST_REF_MON0\[7:0\]](#) and [NOMINAL_NUM_ST_REF_MON1\[7:0\]](#) for CLK_0 and CLK_1 respectively.

There is a comparator that compares an internal counter with the nominal counter value. A hysteresis counter is used to avoid the monitor to flip back and forth on detecting a good/bad reference when it is on the edge. There is an acceptance range and a rejection range that are also programmable.

The acceptance range to be added to the nominal counter value is programmable by setting bits [ACCEPT_NUM_ST_REF_MON0\[3:0\]](#) and [ACCEPT_NUM_ST_REF_MON1\[3:0\]](#) for CLK_0 and CLK_1 respectively.

The rejection range to be added to the nominal counter value is programmable by setting bits [REJECT_NUM_ST_REF_MON0\[3:0\]](#) and [REJECT_NUM_ST_REF_MON1\[3:0\]](#) for CLK_0 and CLK_1 respectively.

There is a counter that counts the number of times the reference is declared good by the short-term reference monitor. This counter is programmable by setting its [GOOD_TIMES_ST_REF_MON0\[3:0\]](#) and [GOOD_TIMES_ST_REF_MON1\[3:0\]](#) for CLK_0 and CLK_1 respectively. This counter is used to clear the fail status bits after the reference has been detected to be good by the number of times set in this register.

There is a counter that counts the number of times the reference is declared invalid by the short-term reference monitor. This counter is programmable by setting its `FAIL_NUM_ST_REF_MON0[3:0]` and `FAIL_NUM_ST_REF_MON1[3:0]` for CLK_0 and CLK_1 respectively. This counter is used to set the fail status bits after the reference has been detected to be bad by the number of times set in this register.

Short-term monitor has a bit associated with it to mask the failure alarm. It also has a bit to mask the interrupt generation. Short-term monitor generates an interrupt if not masked by the associated interrupt mask bit.

It is recommended to always set the acceptance range of the internal counter to be greater than 3, and the rejection number greater than the acceptance range. It is also recommended to set the `GOOD_TIMES_ST_REF_MON0/1` greater than the `FAIL_NUM_ST_REF_MON0/1` to disqualify the reference quicker. The default value for `GOOD_TIMES_ST_REF_MON0/1` is 4 and the default value for the `FAIL_NUM_ST_REF_MON0/1` is 1.

As an example, to declare loss of signal on CLK_0 (1MHz) if one clock cycle is missing. The registers are preprogrammed as follows:

- `DIV_RATIO_ST_REF_MON0[5:0] = 0` (Window size = 1μs)
- `NOMINAL_NUM_ST_REF_MON0[7:0] = 108M/(1M) = 108`
- `ACCEPT_NUM_ST_REF_MON0[3:0] = 5`
- `REJECT_NUM_ST_REF_MON0[3:0] = 11`
- `FAIL_NUM_ST_REF_MON0[3:0] = 1`
- `GOOD_TIMES_ST_REF_MON0[3:0] = 2`

In this example, the acceptance range of the internal counter is from 103 to 113 cycles, and the rejection range is below 98 or greater than 118 cycles. The `CLK_0_FAIL_ST` bit will be set after the short-term reference monitor detects one missing clock (`FAIL_NUM_ST_REF_MON0[3:0]` is set to 1), and it is back to normal after the reference monitor detects two good clock cycles (as `GOOD_TIMES_ST_REF_MON0[3:0] = 2`).

Figure 12. Short-Term Reference Monitor Example (CLK_0 is Missing One Clock Cycle)

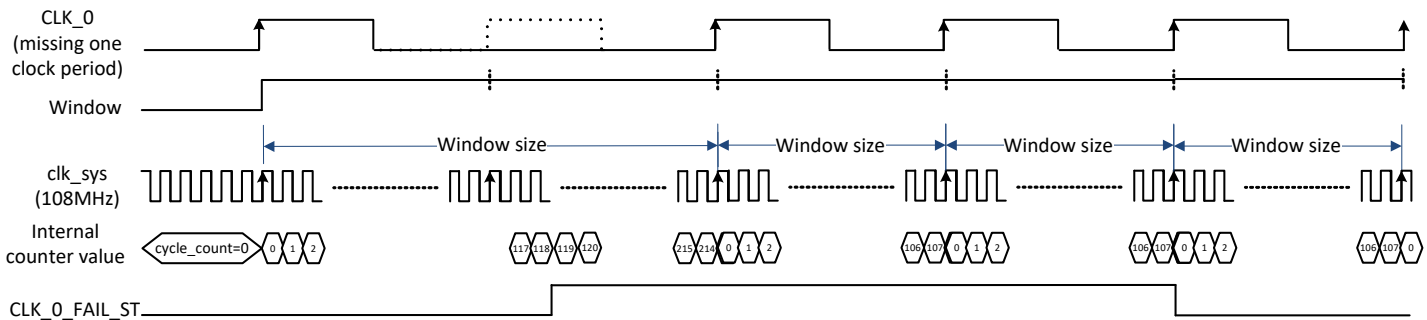

Medium-Term Monitor

Each input clock reference is monitored using the medium-term monitor. The medium-term monitor can be used to detect activity with coarse resolution (i.e., PPM). It supports input clock frequencies above 1kHz.

The medium-term monitor takes the input clock after the input high frequency pre-divider (maximum frequency is 36MHz) and before the input pre-divider. The period of this frequency is used to create a window to compare whether or not the input clock is within a certain frequency. The window size is programmable.

- Window size = T_{REF} (if `DIV_RATIO_MT` is set to 0 or to 1)
- Window size = $(DIV_RATIO_MT+2) \times T_{REF}$
- T_{REF} = period of the input reference clock, after high frequency pre-divider

Where `DIV_RATIO_MT` is programmable by using bits `DIV_RATIO_MT_REF_MON0[15:0]` and `DIV_RATIO_MT_REF_MON1[15:0]` for CLK_0 and CLK_1 respectively.

A counter that is part of the medium-term monitor is used to count the number of system clocks (SYS_CLK that is approximately 108MHz) within the window.

The nominal counter value is calculated as follows:

- $NOMINAL_NUM_MT = f_{SYS_CLK} / f_{REF}$ (if DIV_RATIO_MT is set to 0 or to 1)
- $NOMINAL_NUM_MT = f_{SYS_CLK} / (f_{REF} / (DIV_RATIO_MT + 2))$
- $f_{SYS_CLK} = \sim 108\text{MHz}$
- f_{REF} = frequency of the input reference clock, after high frequency pre-divider

The $NOMINAL_NUM_MT$ value is then set into [NOMINAL_NUM_MT_REF_MON0\[17:0\]](#) and [NOMINAL_NUM_MT_REF_MON1\[17:0\]](#) for CLK_0 and CLK_1 respectively.

There is a comparator that compares an internal counter with the nominal counter value. A hysteresis counter is used to avoid the monitor to flip back and forth on detecting a good/bad reference when it is on the edge. There is an acceptance range and a rejection range that are also programmable.

The acceptance range to be added to the nominal counter value is programmable by setting bits [ACCEPT_NUM_MT_REF_MON0\[15:0\]](#) and [ACCEPT_NUM_MT_REF_MON1\[15:0\]](#) for CLK_0 and CLK_1 respectively.

The rejection range to be added to the nominal counter value is programmable by setting bits [REJECT_NUM_MT_REF_MON0\[15:0\]](#) and [REJECT_NUM_MT_REF_MON1\[15:0\]](#) for CLK_0 and CLK_1 respectively.

There is a counter that counts the number of times the reference is declared good by the medium-term reference monitor. This counter is programmable by setting its [GOOD_TIMES_MT_REF_MON0\[3:0\]](#) and [GOOD_TIMES_MT_REF_MON1\[3:0\]](#) for CLK_0 and CLK_1 respectively. This counter is used to clear the fail status bits after the reference has been detected to be good by the number of times set in this register.

There is a counter that counts the number of times the reference is declared invalid by the medium-term reference monitor. This counter is programmable by setting its [FAIL_NUM_MT_REF_MON0\[3:0\]](#) and [FAIL_NUM_MT_REF_MON1\[3:0\]](#) for CLK_0 and CLK_1 respectively. This counter sets the fail status bits after the reference has been detected to be bad by the number of times set in this register.

If the internal counter value is within the nominal counter value \pm the acceptance range, then the reference is considered good. If the internal counter value is outside the nominal counter value \pm the rejection range, then the reference is considered bad.

Medium-term monitor has a bit associated with it to mask the failure alarm. It also has a bit to mask the interrupt generation. Medium-term monitor generates an interrupt if not masked by the associate interrupt mask bit.

Long-Term Monitor

Each input clock reference is monitored using the long-term monitor. The long-term monitor can be used to detect activity with fine resolution (i.e., ppb). It supports any input clock frequencies reference (as low as 1Hz).

The long-term monitor takes the input clock from after the input high frequency pre-divider (maximum frequency is 36MHz) and before the input pre-divider. The period of this frequency is used to create a window to compare whether or not the input clock is within a certain frequency. The window size is programmable.

- Window size = T_{REF} (if DIV_RATIO_LT is set to 0 or to 1)
- Window size = $(DIV_RATIO_LT + 2) \times T_{REF}$
- T_{REF} = period of the input reference clock, after high frequency pre-divider

Where DIV_RATIO_LT is programmable by using bits [DIV_RATIO_LT_REF_MON0\[28:0\]](#) and [DIV_RATIO_LT_REF_MON1\[28:0\]](#) for CLK_0 and CLK_1 , respectively.

A counter that is part of the long-term monitor is used to count the number of system clocks (SYS_CLK that is approximately 108MHz) within the window. Optionally, $OSCI/OSCO$ or XO_DPLL can be used instead of system clock.

The nominal counter value is calculated as follows:

- $NOMINAL_NUM_LT = f_{SYS_CLK} / f_{REF}$ (if DIV_RATIO_LT is set to 0 or to 1)
- $NOMINAL_NUM_LT = f_{SYS_CLK} / (f_{REF} / (DIV_RATIO_LT + 2))$
- $f_{SYS_CLK} = \sim 108\text{MHz}$
- f_{REF} = frequency of the input reference clock, after high frequency pre-divider

The $NOMINAL_NUM_LT$ value is then set into [NOMINAL_NUM_LT_REF_MON0\[31:0\]](#) and [NOMINAL_NUM_LT_REF_MON1\[31:0\]](#) for CLK_0 and CLK_1 respectively.

There is a comparator that compares an internal counter with the nominal counter value. A hysteresis counter is used to avoid the monitor to flip back and forth on detecting a good/bad reference when it is on the edge. There is an acceptance range and a rejection range that are also programmable.

The acceptance range to be added to the nominal counter value is programmable by setting bits `ACCEPT_NUM_LT_REF_MON0[21:0]` and `ACCEPT_NUM_LT_REF_MON1[21:0]` for CLK_0 and CLK_1, respectively.

The rejection range to be added to the nominal counter value is programmable by setting bits `REJECT_NUM_LT_REF_MON0[21:0]` and `REJECT_NUM_LT_REF_MON1[21:0]` for CLK_0 and CLK_1, respectively.

There is a counter that counts the number of times the reference is declared good by the long-term reference monitor. This counter is programmable by setting its `GOOD_TIMES_LT_REF_MON0[3:0]` and `GOOD_TIMES_LT_REF_MON1[3:0]` for CLK_0 and CLK_1, respectively.

There is a counter that counts the number of times the reference is declared invalid by the long-term reference monitor. This counter is programmable by setting its `FAIL_NUM_LT_REF_MON0[3:0]` and `FAIL_NUM_LT_REF_MON1[3:0]` for CLK_0 and CLK_1, respectively.

If the internal counter value is within the nominal counter value \pm the acceptance range, then the reference is considered good. If the internal counter value is outside the nominal counter value \pm the rejection range, then the reference is considered bad.

Long-term monitor has a bit associated with it to mask the failure alarm. It also has a bit to mask the interrupt generation. Long-term monitor generates an interrupt if not masked by the associate interrupt mask bit.

The input reference clock fractional frequency offset (FFO) can be read back from register.

1PPS Fast Lock

If hitless reference switching is enabled, then the 1PPS fast lock process is disabled.

Both DPLL-0 and DPLL-1 can lock to 1PPS. A fast lock process is implemented to assist locking to 1PPS within 100 seconds. The fast-lock process includes two steps, frequency snap, and phase snap. The frequency snap slope is programmable via a 8-bit register (`DPLL-0_FREQ_SNAP_SLOPE/DPLL-1_FREQ_SNAP_SLOPE`) with LSB of $2^{-40} \times 8000 \times 10^6$ ppm/s.

After the phase snap, the output phase of the clocks will not be aligned with the input. To align the outputs, the output dividers need to be re-synced to align the output clocks with the 1PPS input. The output clock will stop during the re-sync process.

Input to Output Phase Alignment

Phase alignment of outputs to the input clock is enabled by a synchronization process. In this process, the following configuration bits are used to reset frequency dividers to achieve phase alignment:

- `INIT_CLK_A` resets and synchronizes the DPLL-0 feedback divider, the post divider (P0), and the output dividers that are being driven by the APLL-0.
- `INIT_CLK_B` resets and synchronizes the DPLL-1 feedback divider and the post divider (P1)
- `INIT_CLK_C` resets and synchronizes the APLL-2 feedback divider and the output dividers that are being driven by the APLL-2
- `INIT_CLK_D` resets and synchronizes the RF-PLL feedback divider, and the output dividers that are being driven by the RF-PLL

When `INIT_CLK_A`, `INIT_CLK_B`, `INIT_CLK_C` and `INIT_CLK_D` are being applied, the corresponding APLL VCO output clock is blocked from going to the dividers, the dividers are reset and then the VCO clock is released. As a result, all involved state machines are started at the same time and synchronized to each other. The output clocks will stop during this process.

The following configuration bits select the synchronization source for each DPLL/APLL:

- `SEL_SYNC_DPLLn[1:0]` selects the DPLL-0/DPLL-1 synchronization source
- `SEL_SYNC_APLL2[3:0]` selects the APLL-2 synchronization source
- `SEL_SYNC_RFPLL[3:0]` selects the RF_PLL synchronization source

Selecting a synchronization source follows the signal path for the corresponding DPLL/APLL. When locking to 1PPS, the output of the feedback divider must be used as the synchronization signal. The synchronization signal aligns the feedback divider to the output dividers.

Bits `EN_PRESYNC_DPLLn`, `EN_PRESYNC_APLL2`, and `EN_PRESYNC_RFPLL` are used to select the VCO clock before or after synchronization as the feedback clock for the feedback divider for DPLL-0, DPLL-1 APLL-2, and RF-PLL respectively. When locking to a 1PPS input signal, these bits must be set to 1 for the DPLL/APLL locking to 1PPS.

See below a few examples on how to align input to output clocks:

1. DPLL-0 is locked to 156.25MHz and generates 1PPS and 125MHz clocks that are phase aligned to the input.
 - a. Set register bit `EN_PRESYNC_DPLLn` (n=0) to logic low.
 - b. Set register bits `SEL_SYNC_DPLLn[1:0]` (n=0) to value 01.
 - c. Configure the output dividers to generate 156.25MHz, 125MHz, and 1PPS.
 - d. Write the register bit `RELOCK` to reinitialize calibration for all enabled PLLs. Check register status bit `ST_CAL_FIN_p` (p=0). If it reports 1, then calibration is finished, go to the next step.
 - e. Write the register bit `INIT_CLK_A`.
2. DPLL-1 is locked to a 1PPS input, then drives APLL-2; APLL-2 drives QCLK_D0 (125MHz) and QCLK_D1 (156.25MHz). DPLL-1 also drives the RF-PLL, which drives the QCLK_D3 output for generation of 1PPS; the RF-PLL also drives QCLK_R0 to QCLK_R5 for the generation of 122.88MHz and multiples of 122.88MHz). All outputs are phase-aligned to the 1PPS input.
 - a. Set register bit `EN_PRESYNC_DPLLn` (n = 1) to value 1.
 - b. Set register bits `SEL_SYNC_DPLLn[1:0]` (n = 1) to value 10.
 - c. Set register bit `EN_PRESYNC_APLL2` to logic low.
 - d. Set register bits `SEL_SYNC_APLL2[3:0]` to value "1000"
 - e. Set register bit `EN_PRESYNC_RFPLL` to logic low.
 - f. Set register bits `SEL_SYNC_RFPLL[3:0]` to value 1000.
 - g. Configure QCLK_D0 divider to divide by 30 (125MHz - uses APLL-2).
 - h. Configure QCLK_D1 divider to divide by 24 (156.25MHz - uses APLL-2).
 - i. Configure QCLK_D3 divider to divide by 2,494,120,000 (1PPS - uses RF-PLL).
 - j. Configure QCLK_R0 to QCLK_R5 divider to divide by 24 (122.88MHz).
 - k. Write the register bit `RELOCK` to reinitialize calibration for all enabled PLLs. Check register status bit `ST_CAL_FIN_p` (p=1). If it reports 1, then calibration is finished, go to the next step.
 - l. Configure reference monitor, long-term monitor only; short-term and medium-term should be masked for locking to 1PPS.
 - m. Configure DPLL-1, loop bandwidth, feedback divider ratio, reference selection mode, and other settings according to the application.
 - n. After 1PPS has been qualified, the DPLL-1 state machine will move to Lock acquisition state automatically if state machine is set to automatic, or the DPLL-1 state machine can be manually set to lock acquisition, or lock recovery, or normal_lock. DPLL-1 will first do frequency snap and then will do a phase snap automatically.
 - o. Check `LOCK_STS_DPLL1`. If it reports 1, then DPLL-1 is locked and continue on to next step.
 - p. Write the register `INIT_CLK_B`.
 - q. Write the register `INIT_CLK_C`.
 - r. Write the register `INIT_CLK_D`.
3. DPLL-0 is locked to 156.25MHz and generates a 1PPS clock, 125MHz; the RF-PLL generates 122.88MHz clocks. All outputs are aligned to the clock input.
 - s. Set register bit `EN_PRESYNC_DPLLn` (n = 0) to value 0.
 - a. Set register bits `SEL_SYNC_DPLLn[1:0]` (n = 0) to value 01.
 - b. Set register bit `EN_PRESYNC_RFPLL` to value 0.
 - c. Set register bits `SEL_SYNC_RFPLL[3:0]` to value 0100 (uses QCLK_D2 as the sync signal).
 - d. Configure QCLK_D2 to divide by 2,500,000,000 (generates 1PPS through DPLL-0).
 - e. Configure QCLK_D3 to divide by 20 (generates 125MHz through DPLL-0).
 - f. Configure QCLK_R0 to QCLK_R5 to divider by 24 (generates 122.88MHz).
 - g. Write the register bit `RELOCK` to reinitialize calibration for all enabled PLL. Check register status bit `ST_CAL_FIN_p` (p=0). If it reports 1, then calibration is finished, go to the next step.
 - h. Write the register `INIT_CLK_A`.
 - i. Write the register `INIT_CLK_D`.

Input Disqualification by GPIO pins

GPIO pins are used to disqualify any input reference clock. If a GPIO pin is asserted to signal and external LOS, then the corresponding input reference clock will not be available for any of the DLLs to lock to it.

APLL-2

Frequency Plan

The use of APLL-2 is optional. If the APLL-2 is not used as part of the SYS-DPLL (SYNTH_MODE = 1), APLL-2 may generate frequencies not available from APLL-0 and the RF-PLL. APLL-2 locks the pre-divided output of DPLL-0/APLL-0 or DPLL-1/APLL-1. The fractional feedback divider of APLL-2 must be configured to enable the PLL to clock at any frequency in the range $f_{VCO} = 3600\text{-}3868\text{MHz}$. The VCO frequency can be routed to the frequency N_{D0-3} and output at any of the digital outputs QCLK_D0-3.

Figure 13. APLL-2 Frequency Divider

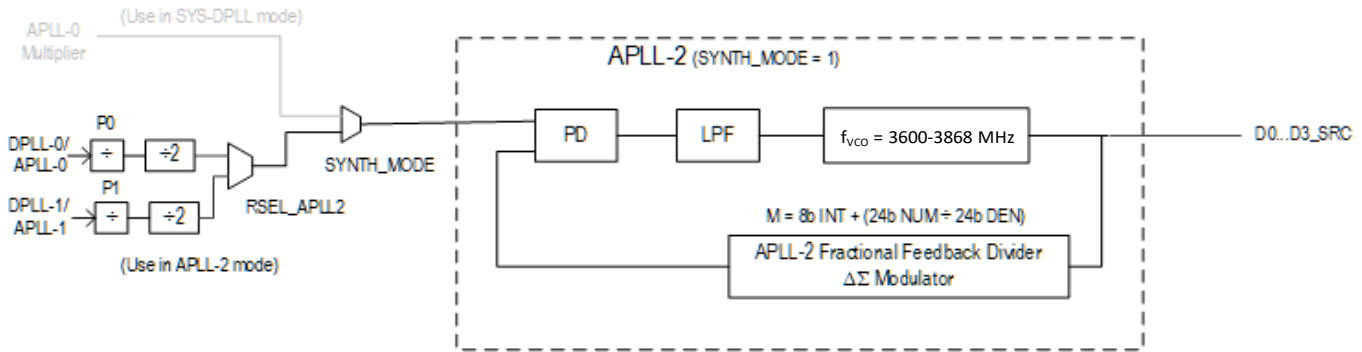

Table 16. APLL-2 Frequency Configuration

Block	Frequency	Description	Register
APLL-2 Fractional feedback divider	$f_{VCO} = f_{REF,APLL-2} \times [M_INT + (M_NUM \div M_DEN)]$	8-bit Integer portion	M_INT_APLL2[7:0]
		24-bit Numerator	M_NUM_APLL2[23:0]
		24-bit Denominator	M_DEN_APLL2[23:0]

Table 17. APLL-2 Output Divider Values

Divider Setting	Range	Operation for $f_{VCO} = 3600\text{-}3868\text{MHz}$	
		APLL	Example
Output Divider N_d ($d = D0, D1, D2, D3$)	$N = \{1, 2, 3, 4, 5, 9, 15, 25\} \times 2^m$ with $m = 0$ to 6 Range: $N = \div 1$ to $\div 1,600$	Output frequency ($f < 1\text{GHz}$) $f_{OUT} = \frac{f_{VCO}}{N_d}$	161.1328125MHz 644.53125MHz
Output Divider N_{D1D0_EXT} and N_{D3D2_EXT}	Extends divider N_d Range: $EXT = \div 1$ to $\div 4,194,302$ Total range $N_d \times EXT = \div 1$ to $\div 6,710,883,200$ For divider setting, see N_D1D0_EXT[20:0] and N_D2D3_EXT[20:0] .	Output frequency ($f < 1\text{GHz}$) $f_{OUT} = \frac{f_{VCO}}{N_d \times N_{EXT}}$	1Hz (1PPS)

Crystal Oscillator Interface (XO_DPLL/nXO_DPLL)

This reference clock input is available to the System DPLL block. The input supports single-ended (LVCMOS) and differential external oscillators. The input is intended to be used to provide a stable frequency reference, such as a TCXO or OCXO to the System DPLL. This input is not required in all cases. The crystal oscillator frequency accuracy should be chosen accordingly to meet different applications and standard requirements. (See application note *AN-807 Recommended Crystal Oscillators for NetSynchro WAN PLL*).

Crystal Interface (OSCI/OSCO)

The 8V19N850DNLGI can use a 25MHz–54MHz crystal input on the OSCI / OSKO pins. This input drives the System APLL which is the source for all internal clocks (see [Table 132](#)). The crystal input can alternatively be overdriven by a crystal oscillator (for more information, see [External Oscillator Characteristics](#)). The external XTAL can be used for close-in phase noise improvements.

Digital Frequency Domains

DPLL-0 (APLL-0 at 2450-2580MHz) is the dedicated, narrow-band PLL for generating the “digital” clocks such as 156.25, 125, and 100MHz by integer division of the output frequency of APLL-0. The APLL-0 signal can be routed to any of the outputs QCLK_d (QCLK_D0 to D3).

APLL-2 (3600-3868MHz) has a wider frequency range than APLL-0. The wider frequency range allows the generation of frequencies not available from DPLL-0/APLL-0 (e.g., 161.1328125MHz generated by setting the VCO frequency to 3867.1875MHz and then dividing by 24). The APLL-2 input and feedback frequency dividers must be configured to achieve PLL lock in the frequency range of 3600-3868MHz.

The outputs QCLK_D0-D1 can select from two frequency sources APLL-2 (3600-3868MHz) and APLL-0 (2450-2580MHz). The clock outputs QCLKD2-D3 can select from three frequency sources: APLL-2 (3600-3868MHz), APLL-0 (2450-2580MHz), and RF-PLL (2949.12MHz).

The output clock is generated by integer frequency division (N_d dividers) from the selected APLL. The N_d frequency dividers can be extended in its divider value by using the N_{D1D0_EXT} and N_{D3D2_EXT} frequency dividers. The extended dividers allow to divide down the APLL frequencies to 1Hz (1PPS) and lower.

Figure 14. Digital Clocks Frequency Divider

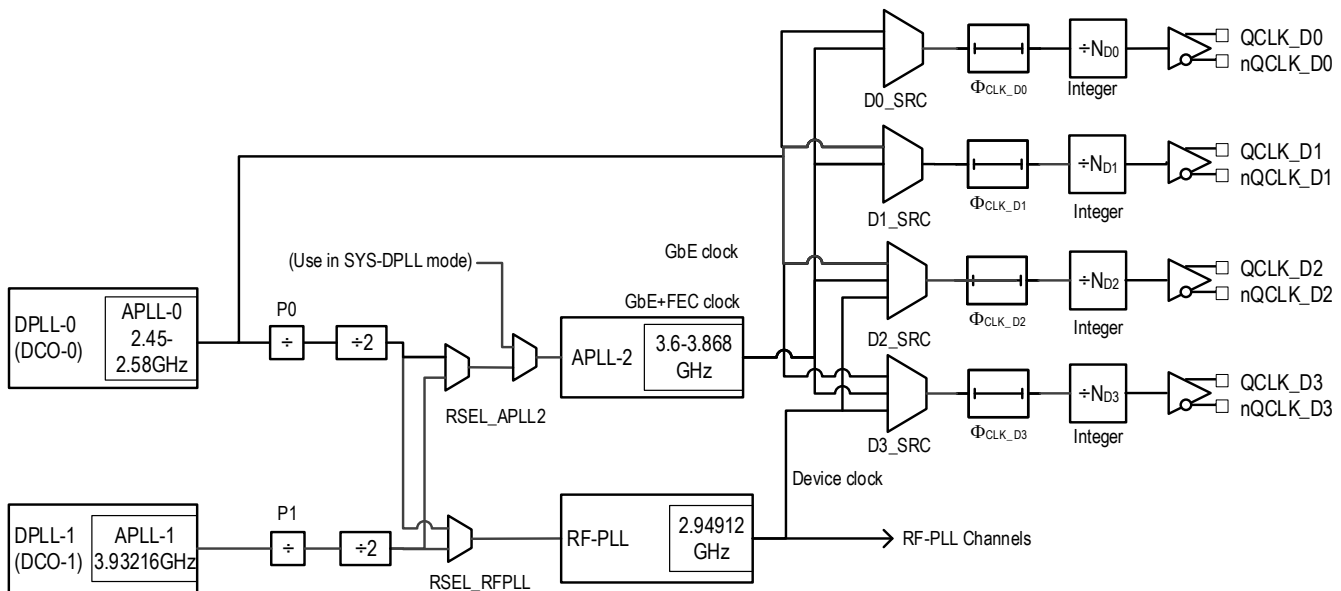

Table 18. DPLL-0/APLL-0 Output Frequency Operation and Divider Values

Divider Setting	Range	Operation for $f_{VCO} = 2450\text{-}2580\text{MHz}$	
		DPLL-0	Example
Output Divider N_d ($d = D0, D1, D2, D3$)	$N = \{1, 2, 3, 4, 5, 9, 15, 25\} \times 2^m$ with $m = 0$ to 6 Range: $N = \div 1$ to $\div 1600$	Output frequency ($f < 1\text{GHz}$) $f_{OUT} = \frac{2500\text{MHz}}{N_d}$	312.5MHz 156.25MHz 125MHz 100MHz
Output Divider N_{D1D0_EXT} and N_{D3D2_EXT}	Extends divider N_d Range: $EXT = \div 1$ to $\div 4,194,302$ Total range $N_d \times EXT = \div 1$ to $\div 6,710,883,200$ For divider settings, see N_D1D0_EXT[20:0] and N_D2D3_EXT[20:0] .	Output frequency ($f < 1\text{GHz}$) $f_{OUT} = \frac{2500\text{MHz}}{N_d \times N_{EXT}}$	1Hz (1PPS)

Converter Clock Domain and RF-PLL

RF-PLL Channel

The four RF-PLL channels R0 to R3 consist of two or one QCLK_y outputs and two or one associated SYSREF outputs QREF_r. The SYSREF output(s) in a channel generate synchronization signals for JESD204B/C circuits. The channel logic controls the outputs: outputs automatically turn on and off in a SYSREF sequence.

The RF-PLL locks to DPLL-0/APLL-0 or DPLL-0/APLL-1, selected by RSEL_RFPLL. The post-divider (P0, P1) of the selected source APLL scales the APLL output frequency to an input frequency of less than 250MHz (< 160MHz if APLL-2 is in fractional mode). Both post-divider and RF-PLL feedback divider M_INT_RFPLL must be configured to achieve PLL lock at the VCO frequency of 2949.12MHz. The RF-PLL is internally configured to high-bandwidth. The RF-PLL feedback divider (M_INT_RFPLL) uses integer feedback divider circuits for best possible AC performance such as phase noise generation and spurious suppression.

Figure 15. RF-PLL Frequency Divider

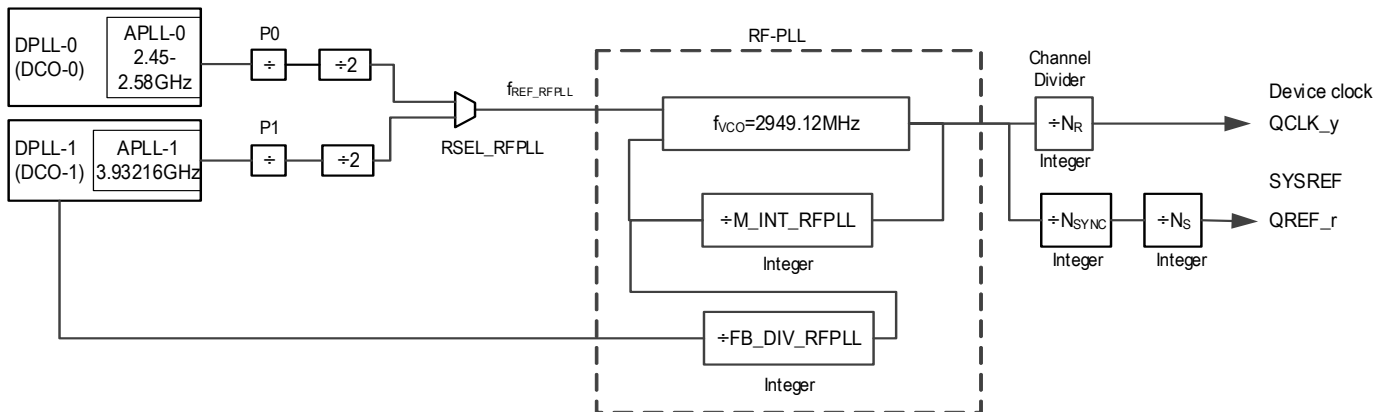

Table 19. M_RFPLL Frequency Configuration

RF_PLL Operation	Description	Register
$f_{VCO} = f_{REF_RF_PLL} \times M_INT_RFPLL$	8-bit integer	M_INT_RFPLL[7:0]
$f_{VCO} = f_{REF_DPLL_1} \times FB_DIV_RFPLL$ (if going to DPLL-1)	4-bit integer	FB_DIV_RFPLL[3:0]

RF-PLL Channel Frequency Divider

RF Clock Frequency Generation

The device supports four independent RF clock channels R0 to R3. Each channel has one frequency divider N_x ($x = R0$ to $R3$) that divides the VCO frequency of the RF-PLL to the desired output frequency. Each divider can be individually set to various values in the range of $\div 1$ to $\div 25,600$. The RF clock channels R0 to R3 support output frequencies at the QCLK_y outputs up to the VCO frequency of the RF-PLL (2949.12MHz).

SYREF Signal Frequency Generation

The frequency dividers N_{SYNC} and N_S set the SYSREF frequency of the QREF_r outputs: the total divider value is $N_{SYNC} \times N_S$. N_{SYNC} should be set to a common multiple value of output dividers N_x ($x = R0$ - $R3$) that is equal to or greater than 12. Example: Generate a 7.68MHz SYSREF frequency with $N_{R0} = \div 12$ (245.76 MHz output frequency), $N_{R1} = \div 24$ (122.88 MHz output frequency), $N_{R2} = \div 16$ (184.32 MHz output frequency), and $N_{R3} = \div 2$ (1474.56 MHz output frequency). A value fulfilling the common multiple criteria is $\div 48$. Set $N_{SYNC} = \div 48$ and $N_S = \div 8$ ($N_{SYNC} \times N_S = \div 384$; $2949.12\text{MHz} \div 384 = 7.68\text{MHz}$). Failure to configure the N_{SYNC} divider to a common multiple of the channel clock dividers N_x can result in a loss of phase alignment between QCLK_r and QREF_r outputs. For the divider values, see the following table.

Table 20. RF-PLL Channel/Output Divider Values

Divider Setting	Range	Operation for $f_{VCO} = 2949.12\text{MHz}$	
		RF-PLL	Example Output Frequency
Channel Divider N_x ($x = R0$ to $R3$)	$N = \{1, 2, 3, 4, 5, 9, 15, 25\} \times 2^m$ with $m = 0$ to 10 Range: $N = \div 1$ to $\div 25,600$	Channel/Output frequency $f_{OUT} = \frac{f_{VCO}}{N_x}$	122.88MHz 245.76MHz 491.52MHz
Output Divider N_d ($d = D2, D3$)	$N = \{1, 2, 3, 4, 5, 9, 15, 25\} \times 2^m$ with $m = 0$ to 6 Range: $N = \div 1$ to $\div 25,600$	Output frequency ($f < 1\text{GHz}$) $f_{OUT} = \frac{f_{VCO}}{N_x}$	
Output Divider N_{D3D2_EXT}	Extends divider N_d Range: $EXT = \div 1$ to $\div 4,194,302$ Total range $N_d \times EXT = \div 1$ to $\div 6,710,883,200$ See N_D2D3_EXT[20:0] for divider settings	Output frequency ($f < 1\text{GHz}$) $f_{OUT} = \frac{f_{VCO}}{N_d \times N_{EXT}}$	1Hz (1PPS)
Divider N_{SYNC}^a	$N_{SYNC} = \{1, 2, 3, 4, 5\} \times 2^n$ with $n = 0$ to 10	SYSREF frequency/rate $f_{SYSREF} = \frac{f_{VCO}}{N_S \times N_{SYNC}}$	1.92MHz 7.68MHz
SYSREF Divider N_S	$N_S = 2^p$ with $p = 1$ to 9		

a. Total SYSREF divider range ($N_S \times N_{SYNC}$): $\div 2$ to $\div 2,621,400$. N_{SYNC} should be set to a common divider value of all output dividers N_x ($x = R0$ to $R3$) and be larger than or equal to $\div 12$.

Configuration for JESD204B Operation

Synchronizing SYSREF and Clock Output Dividers

The N_SYNC divider controls the release of SYSREF pulses at coincident QCLK_y clock edges. For SYSREF operation, set the N_SYNC divider value to a common multiple of the clock divider values N_x that is equal to or greater than 12.

SYSREF Generation

A SYSREF event is the generation of one or more consecutive pulses on the QREF_r outputs. The frequency (pulse rate) of the SYSREF signal is set by the VCO frequency of the RF-PLL and the N_S and N_SYNC frequency dividers. An event can be triggered by a SPI command or by a signal-transition on the EXT_SYS input. The number of SYSREF pulses generated and wait periods in between SYSREF pulses is programmable. The SYSREF signal can also be programmed to be continuous and be started and stopped by a signal on the EXT_SYS input. The SYSREF pulse rate is configurable to the frequencies shown in Table 21. SYSREF output pulses are aligned to coincident rising clock edges of the clock outputs QCLK_y. Device settings for phase alignment between QCLK_y and QREF_r outputs is detailed in the section, *Synchronizing SYSREF and Clock Output Dividers*. The SYSREF pulse generation modes in Table 21 are available and configurable by SPI.

Table 21. SYSREF Generation Modes

SRG[2:0]	Operation	SYSREF Frequency	Pulsed Mode SRO[1:0] ^{a b}	Notes
000	EXT_SYS input signal is buffered out to all SYSREF outputs	same as EXT_SYS	same as EXT_SYS	Requires external synchronization
001	EXT_SYS input signal is synchronized to the incident edge of the QCLK outputs and buffered out to all SYSREF outputs	same as EXT_SYS	same as EXT_SYS	
010	Externally triggered mode	$f_{\text{SYSREF}} = \frac{f_{\text{VCO}}}{N_S \times N_{\text{SYNC}}}$	00: pulsed, rising edge trigger 01: pulsed, falling edge trigger 10: rising edge starts pulses; falling edge stops pulses 11: falling edge starts pulses; rising edge stops pulses	
011	Internally triggered mode		00: pulsed 01: reserved 10: reserved 11: pulsed with auto repeat	
100	Continuous SYSREF mode		–	

- a. In pulsed mode, SRPC defines the number of pulses to generate before SYSREF stops.
- b. In pulsed mode with auto repeat, SRPC defines the number of pulses to generate and SRWC the number of VCO cycle SYSREF waits before repeating to generate pulses.

The generation of SYSREF pulses is configured by commands through the serial interface and is available after the initial setup of output clock divider and QREF phase delay stages. A SYSREF event will automatically turn on the SYSREF outputs in pulsed mode.

Figure 16. RF-PLL JESD204B Circuit Diagram

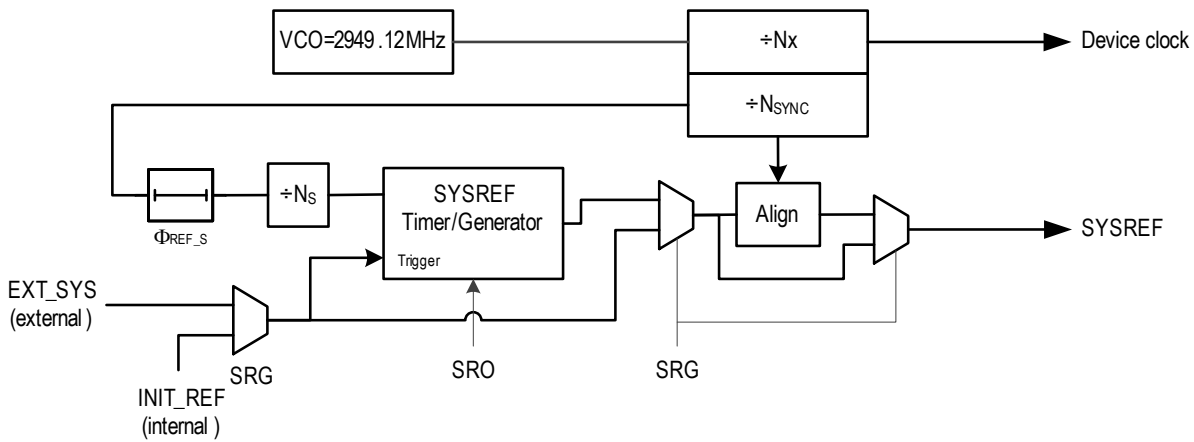
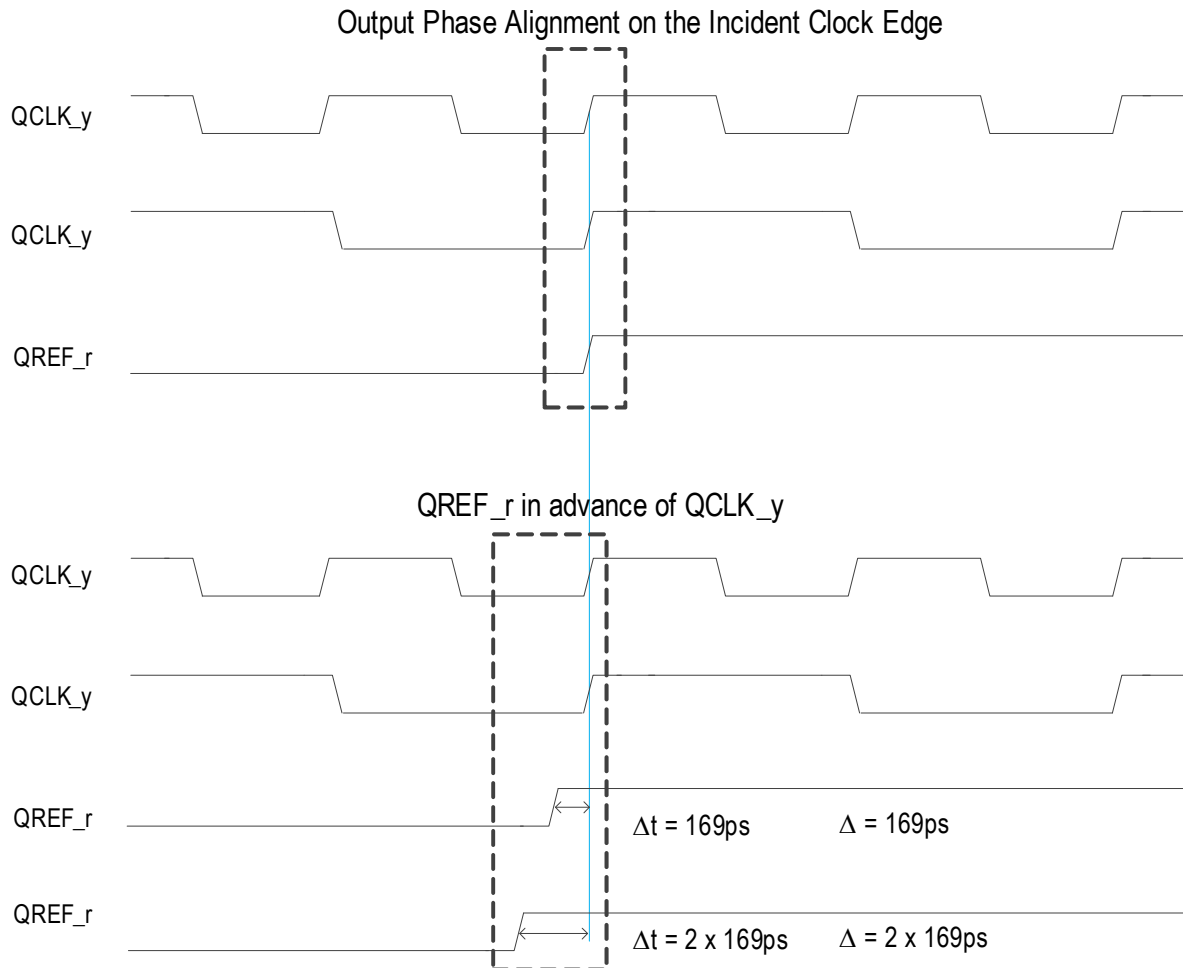

Figure 17. QCLK_y to QREF_r Phase Alignment



SYSREF Phase Alignment and Activation

The following procedure describes the recommended steps for an initial synchronization and alignment of SYSREF outputs QREF_r to the RF-PLL clock outputs QCLK_y and to enable the outputs.

1. Establish a configuration of the device according to the desired input and RF-PLL output frequencies on QCLK_y.
2. Configure the SYSREF functional block and the QREF_r outputs.
 - a. Set the SYSREF frequency: configure the N_S and N_SYNC register (see [SYSREF Signal Frequency Generation](#)).
 - b. Set the desired SYSREF pulse generation modes (see [SYSREF Generation Modes](#)).
 - c. Configure the QREF_r output (amplitude, style, offset voltage, and SYSREF_AC output coupling) as desired.
 - d. Configure the global SYSREF phase delay $\Phi_{REF_S}[7:0]$. Φ_{REF_S} settings are not effective before step 4.
 - e. Configure individual output phase delay registers Φ_{REF_R} as desired for phase alignment of the QREF_r outputs to the incident phase of the QCLK_y outputs. Φ_{REF_R} settings are effective immediately.
3. Power-on and configure SYSREF generation blocks and outputs.
 - a. Set PD_S = 0 and set PD_SYSREF = 0 (power on SYSREF function).
 - b. Enable the SYSREF outputs by setting QREF_ALL_EN = 1.
 - c. Power on the QREF_r outputs desired for SYSREF operation (set register bits QREF_R0_PD to QREF_R5_PD to 0).
4. Internal synchronization and SYSREF activation.
 - a. Set INIT_CLK_D = 1. Resets and synchronizes the RF-PLL feedback divider M with the output dividers N_x, N_r, N_D2, N_D3 that are driven by RF-PLL. During this step, the QCLK_r outputs (also: QCLK_D2 and QCLK_D3 if driven by RF-PLL) are at logic low state (interrupted in generating clocks).
 - b. Set INIT_REF = 1. This step starts an initialization (synchronization) for the SYSREF divider N_S.

The QREF_r outputs are now active and generate SYSREF pulses according to the SYSREF mode described in [SYSREF Generation Modes](#). When SYSREF is operating in continues mode (SRG = 100), set SRG to 011 (internally triggered mode) to stop SYSREF. A repeated SYSREF activation only requires to set INIT_REF = 1 once. Any change of output dividers or $\Phi_{REF_S}[7:0]$ global delay register value requires to repeat setting INIT_CLK_D. Changing the individual output phase delay registers Φ_{REF_R} changes the output delay immediately and does not require step 4.

Differential Outputs

Table 22. Output Features

Output	Style	Amplitude ^a for V _{DDO_V}		VOS Ctrl. ^b	Enable/Disable	Power Down	Slew Rate Ctrl.	Drive strength Ctrl.	Termination ^c
		3.3V	2.5V and 1.8V						
QCLK_y, QREF_r (RF-PLL Clocks)	LVPECL	350, 500, 750, 1000mV	350, 500mV	—	Yes	Yes	—	—	50Ω to V _T
	LVDS	350, 500mV		Yes					100Ω differential
QCLK_d (Digital Clocks)	LVPECL	350, 500, 750, 1000mV	350, 500mV	—	Yes	Yes	—	—	50Ω to V _T
	LVDS	350, 500mV		Yes					100Ω differential
	LVC MOS	3.3V	2.5V, 1.8V	—					Yes
QREF_r (SYSREF)	LVPECL	350, 500, 750, 1000mV	350, 500mV	—	Yes	Yes	—	—	50Ω to V _T
	LVDS	350, 500mV		Yes					100Ω differential

a. Amplitudes are measured in a single-ended manner. Differential amplitudes are 700, 1000, 1500, and 2000mV (LVPECL) and 700, 1000mV (LVDS).
 b. The LVDS crosspoint level (VOS) is configurable. The setting VOS = 1.25V is available if V_{DDO_V} = 3.3V.
 c. AC coupling and DC coupling supported.

Table 23. QCLK_y Individual Clock Output Settings

PD ^a	STYLE	EN ^b	A[1:0] ^c	Output Power	Termination	State	Amplitude (mV)
1	X	X	X	Off	100Ω differential or no termination	Off	X
0	0	0	XX	On	50Ω to V _T (LVPECL)	Disable (logic low)	X
		1	00		50Ω to V _T = V _{DDO_V} - 1.50V (LVPECL)	Enable	350
			01		50Ω to V _T = V _{DDO_V} - 1.75V (LVPECL)		500
			10 ^d		50Ω to V _T = V _{DDO_V} - 2.00V (LVPECL)		750
			11 ^d		50Ω to V _T = V _{DDO_V} - 2.25V (LVPECL)		1000
			0		XX		Disable (logic low)
	1	1	00		100Ω differential (LVDS)	Enable	350
			01				500
			10				
			11				

- a. Power-down modes are available for the individual channels and the outputs QCLK_y.
- b. Output enable is supported on each individual QCLK_y output.
- c. Output amplitude control is supported on each individual QCLK_y output.
- d. V_{DDO_V} = 3.3V only.

Table 24. QREF_r Individual SYSREF Output Settings

PD ^a	STYLE	EN ^b	A[1:0] ^c	Output Power	Termination	State	Amplitude (mV)
1	X	X	X	Off	100Ω differential or no termination	Off	X
0	0	0	XX	On	50Ω to V _T (LVPECL)	Disable (logic low)	X
		1	00		50Ω to V _T = V _{DDO_V} - 1.50V (LVPECL)	Enable	350
			01		50Ω to V _T = V _{DDO_V} - 1.75V (LVPECL)		500
			10 ^d		50Ω to V _T = V _{DDO_V} - 2.00V (LVPECL)		750
			11 ^d		50Ω to V _T = V _{DDO_V} - 2.25V (LVPECL)		1000
			0		XX		Disable (logic low)
	1	1	00		100Ω differential (LVDS)	Enable	350
			01				500
			10				
			11				

- a. Power-down modes are available for the individual channels and the outputs QREF_r.
- b. Output enable is supported on each individual QREF_r output.
- c. Output amplitude control is supported on each individual QREF_r output.
- d. V_{DDO_V} = 3.3V only.

Output Phase-Delay

Output phase delay is supported on each DPLL, each clock output channel, on each QREF_r output and for SYSREF global. The delay circuit of each DPLL allows for achieving phase alignment between clock inputs and outputs. The DPLL delay range encompasses more than one UI (input) and therefore can align 1PPS signals. The delay circuits in the clock channels are for setting further delay values (e.g., for achieving specific phase relationships between clock output).

The global SYSREF delay circuit impacts all QREF outputs: it sets the rising edge of SYSREF signals close to desired phase position of the incident QCLK_y rising edge. The individual QREF_r output delay circuits are fine alignment of SYSREF outputs to device clocks (QCLK_y) for JESD204B/C operation.

Table 25. Delay Circuit Settings

Delay Circuit	Unit	Steps	Range (ns)	Alignment ^a
Clock Φ_{DPLL}	18ps	2^{36}	Larger than 1UI (1PPS) $-(18ps \times 618,475,290,624)$ to $+(18ps \times 618,475,290,623)$ or -618.4 ms to 618.4ms	Use for any input to output phase alignment
Clock Channel Φ_{CLK_d}	Exact digital delay: $\frac{1}{2f_{VCO}}$	2^9 (512)	$0 - 511 \times (1/f_{VCO})$ f_{VCO} = VCO frequency of the APLL driving the channel	Incident rising clock edges of clocks in the same domain can be aligned.
RF Clock Channel Φ_{CLK_x}	Exact digital delay: $\frac{1}{2f_{VCO}} = 169ps$	2^9 (512)	0 – 86.359	Incident rising clock edges are aligned, independent on the divider N_x (x=R0-R3) across channels.
SYSREF Φ_{REF_r} ^b	Exact digital delay: $\frac{1}{2f_{VCO}} = 169ps$	2^3 (8)	0 – 1.187	SYSREF rising edge is aligned to the incident rising clock edge across channels
	Analog Delay: 75ps	2	0, 0.075	
SYSREF (Global) Φ_{REF_S}	$\frac{1}{2f_{VCO}} = 169ps$	2^9 (512)	0 – 86.359	Global alignment of SYSREF signals.

a. Default configuration.

b. Total delay value: Digital + Analog delay. The analog delay value may vary from 60ps to 90ps.

General Purpose Input/Outputs (GPIOs)

The four GPIO signals provide a flexible method managing the control and status of the part via the GPIO[3:0] pins without providing dedicated pins for each possible function of the device. The GPIOs are fully configurable so that any GPIO can perform any function on any target logic block.

Each GPIO pin can be individually configured to operate in one of the following modes:

- General Purpose Input – In this mode, the GPIO pin will act as an input whose logic level will be monitored and reflected in an internal register that may be read over the serial port. This is the default mode.
- General Purpose Output – In this mode, the GPIO pin will act as an output that is driven to the logic level specified in an internal register. That register may be written over the serial port.

At startup, the GPIO input pin state is sampled to determine an internal configuration to load (for information, see [GPIO Pin Configuration at Startup](#)).

GPIO Pin Configuration

The GPIO pins (GPIO[3:0]) are all powered from a separate voltage supply. Configure the SELSV2 register bit to indicate which voltage level is being used on the GPIO pins (1.8V, 3.3V). SELSV2 is a global setting for all four GPIO pins. The configuration bits for the GPIO I/O type and GPIO function selectors are located in registers 0x0300-0x0303. GPIO types and functions are also specified in the each of the four internal startup configurations. An EEPROM load does not affect the GPIO configuration of the registers 0x0300-0x0303. A GPIO configuration can be changed at any time after the device completed its startup, indicated by the assertion of the READY signal at the GPIO3 pin (the pin state is a copy of the register bit DEVICE_RDY_STS).

Note: Any programmed GPIO must not be used until the device has reached “Device Ready.” Renesas recommends to wait for “Device Ready Status” (see Table 29) before using any other GPIO signal.

Table 26, Table 27, Table 28, and Table 29 define the selectable function for the GPIO0, GPIO1, GPIO2, and GPIO3 pins, respectively. If more than one GPIO input is assigned to the same function, the GPIO pin of lowest index number takes precedence.

Table 26. GPIO0 Selectable Functions

Register	GPIO0 Pin		
GPIO_0	Type	Function	Description
0000	Output	Interrupt	0 = No interrupt 1 = Interrupt
0001	Output	CLK_0 activity	0 = Clock input 0 activity alarm (input invalid) 1 = Clock input 0 valid
0010	Output	DPLL-1 feedback clock	Reserved
0011	Output	DPLL-1 lock status	DPLL-1 lock status 0 = Loss of lock 1 = Locked
0100	Output	APLL-0 lock status	APLL-0 lock status 0 = Loss of lock 1 = Locked
0101	Output	APLL-1 lock status	APLL-1 lock status 0 = Loss of lock 1 = Locked
0110	Input	DPLL-0 Input Selection	Selects DPLL-0 input reference when in pin selection mode 0 = CLK_0 is the selected input 1 = CLK_1 is the selected input
0111	Input	CLK_0 Disqualify	Disqualification of CLK_0 input 0 = CLK_0 disable/enable set by DIS_REF0 bit and input monitor 1 = CLK_0 is disabled
1000	Input	CLK_1 Disqualify	Disqualification of CLK_1 input 0 = CLK_1 disable/enable set by DIS_REF1 bit and input monitor 1 = CLK_1 is disabled
1001	Input	Output Enable 0	Output enable for output group 0: QCLK_R0 and QCLK_R1. 0 = Disable/enable state is set by register bit EN_R1R0 1 = Enable outputs in group 0

Table 26. GPIO0 Selectable Functions (Cont.)

Register	GPIO0 Pin		
GPIO_0	Type	Function	Description
1010	Input	Output Enable 1	Output enable for output group 1: QCLK_R2 and QCLK_R3. 0 = Disable/enable state is set by register bit EN_R3R2 1 = Enable outputs in group 1
1011	Input	Output Enable 2	Output enable for output group 2: QCLK_R4. 0 = Disable/enable state is set by register bit EN_R4 1 = Enable outputs in group 2
1100	Input	Output Enable 3	Output enable for output group 3: QCLK_R5. 0 = Disable/enable state is set by register bit EN_R5 1 = Enable outputs in group 3
1101	Input	Output Enable 4	Output enable for output group 4: QREF0 to QREF6 (6 outputs). 0 = Disable/enable state is set by register bit QREF_ALL_EN 1 = Enable outputs in group 4
1110	Input	Output Enable 5	Output enable for output group 5: QCLK_D0 and QCLK_D1. When configured to LVCMOS, the function applies to both outputs of each pair. 0 = Disable/enable states is set by register bits EN_D0 and EN_D1 1 = Enable outputs in group 5
1111	Input	Output Enable 6	Output enable for output group 6: QCLK_D2 and QCLK_D3. When configured to LVCMOS, the function applies to both outputs of each pair. 0 = Disable/enable states is set by register bits EN_D2 and EN_D3 1 = Enable outputs in group 6

Table 27. GPIO1 Selectable Functions

Register	GPIO1 Pin		
GPIO_1	Type	Function	Description
0000	Output	Interrupt	0 = No interrupt 1 = Interrupt
0001	Output	CLK_1 activity	0 = Clock input 1 activity alarm (input invalid) 1 = Clock input 1 valid
0010	Output	SYS_APLL Feedback clock	Reserved
0011	Output	DPLL-1 lock status	DPLL-1 lock status 0 = Loss of lock 1 = Locked
0100	Output	APLL-1 lock status	APLL-1 lock status 0 = Loss of lock 1 = Locked

Table 27. GPIO1 Selectable Functions (Cont.)

Register	GPIO1 Pin		
GPIO_1	Type	Function	Description
0101	Output	RF-PLL lock status	RF-PLL-1 lock status 0 = Loss of lock 1 = Locked
0110	Input	DPLL-1 Input Selection	Selects DPLL-0 input reference when in pin selection mode 0 = CLK_0 is the selected input 1 = CLK_1 is the selected input
0111	Input	CLK_0 Disqualify	Disqualification of CLK_0 input 0 = CLK_0 disable/enable set by DIS_REF0 bit and input monitor 1 = CLK_0 is disabled
1000	Input	CLK_1 Disqualify	Disqualification of CLK_1 input 0 = CLK_1 disable/enable set by DIS_REF1 bit and input monitor 1 = CLK_1 is disabled
1001 1010 1011 1100 1101 1110 1111	Input	Output Enable 0 Output Enable 1 Output Enable 2 Output Enable 3 Output Enable 4 Output Enable 5 Output Enable 6	Group 0: Same as for register GPIO_0 Group 1: Same as for register GPIO_0 Group 2: Same as for register GPIO_0 Group 3: Same as for register GPIO_0 Group 4: Same as for register GPIO_0 Group 5: Same as for register GPIO_0 Group 6: Same as for register GPIO_0

Table 28. GPIO2 Selectable Functions

Register	GPIO2 Pin		
GPIO_2	Type	Function	Description
0000	Output	Interrupt	0 = No interrupt 1 = Interrupt
0001	Output	CLK_0 activity	0 = Clock input 0 activity alarm (input invalid) 1 = Clock input 0 valid
0010	Output	DPLL-0 holdover status	0 = DPLL-0 not in holdover 1 = DPLL-0 in holdover
0011	Output	DPLL-1 holdover status	0 = DPLL-1 not in holdover 1 = DPLL-1 in holdover
0100	Output	DPLL-0 lock status	DPLL-0 lock status 0 = Loss of lock 1 = Locked
0101	Output	DPLL-1 lock status	DPLL-1 lock status 0 = Loss of lock 1 = Locked

Table 28. GPIO2 Selectable Functions (Cont.)

Register	GPIO2 Pin		
GPIO_2	Type	Function	Description
0110	Output	APLL-0 lock status	APLL-0 lock status 0 = Loss of lock 1 = Locked
0111	Output	RF-PLL lock status	RF-PLL lock status 0 = Loss of lock 1 = Locked
1000	Input	DPLL-0 Input Selection	Selects DPLL-0 input reference when in pin selection mode 0 = CLK_0 is the selected input 1 = CLK_1 is the selected input
1001 1010 1011 1100 1101 1110 1111	Input	Output Enable 0 Output Enable 1 Output Enable 2 Output Enable 3 Output Enable 4 Output Enable 5 Output Enable 6	Group 0: Same as for register GPIO_0 Group 1: Same as for register GPIO_0 Group 2: Same as for register GPIO_0 Group 3: Same as for register GPIO_0 Group 4: Same as for register GPIO_0 Group 5: Same as for register GPIO_0 Group 6: Same as for register GPIO_0

Table 29. GPIO3 Selectable Functions

Register	GPIO3 Pin		
GPIO_3	Type	Function	Description
0000	Output	Interrupt	0 = No interrupt 1 = Interrupt
0001	Output	CLK_0 activity	0 = Clock input 0 activity alarm (input invalid) 1 = Clock input 0 valid
0010	Output	CLK_1 activity	0 = Clock input 1 activity alarm (input invalid) 1 = Clock input 1 valid
0011	Output	Device ready status	0 = Device has not completed initialization 1 = Device has completed initialization and can be accessed from any serial interface for configuration changes
0100	Output	DPLL-0 lock status	DPLL-0 lock status 0 = Loss of lock 1 = Locked
0101	Output	DPLL-1 lock status	DPLL-1 lock status 0 = Loss of lock 1 = Locked

Table 29. GPIO3 Selectable Functions (Cont.)

Register	GPIO3 Pin		
GPIO_3	Type	Function	Description
0110	Output	APLL-1 lock status	APLL-1 lock status 0 = Loss of lock 1 = Locked
0111	Output	APLL-2 lock status	APLL-2 lock status 0 = Loss of lock 1 = Locked
1000	Input	DPLL-1 Input Selection	Selects DPLL-1 input reference when in pin selection mode 0 = CLK_0 is the selected input 1 = CLK_1 is the selected input
1001 1010 1011 1100 1101 1110 1111	Input	Output Enable 0 Output Enable 1 Output Enable 2 Output Enable 3 Output Enable 4 Output Enable 5 Output Enable 6	Group 0: Same as for register GPIO_0 Group 1: Same as for register GPIO_0 Group 2: Same as for register GPIO_0 Group 3: Same as for register GPIO_0 Group 4: Same as for register GPIO_0 Group 5: Same as for register GPIO_0 Group 6: Same as for register GPIO_0

GPIO Pin Configuration at Startup

- GPIO0 and GPIO1 pins are always inputs during the device startup and are sampled at the rising edge of the internal reset signal. The sampled selects the initial device configuration to load.
- GPIO2 and GPIO3 pins are always outputs during device startup and indicate device status information.

Table 30 shows which GPIO pins are used to control what aspects of the initial configuration. All of these register settings can be overwritten later via serial port access.

Table 30. GPIO Pin Configuration At Startup

GPIO Pin	Type	Default ^a	Function
0	Input	00	00 = The device loads a configuration from the internal read-only storage 0 01 = The device loads a configuration from the internal read-only storage 1 10 = The device loads a configuration from the internal read-only storage 2 11 = The device loads a configuration from the internal read-only storage 3
1	Input		
2	Output	-	APLL-0 Lock indicator 0 = APLL-0 is not locked 1 = APLL-0 is locked
3	Output	-	READY indicator 0 = Device has not completed initialization 1 = Device has completed initialization and can be accessed from any serial interface for configuration changes

a. Via internal pull-down or pull-up, which can be overwritten by external resistors.

Power-up and Internal Reset

Power Supply Sequence

1. Power up the output power supplies (V_{DDO_V} at 3.3V, 2.5V, or 1.8V) first.
2. Then, power up the remaining power supplies (V_{DD_V} at 3.3V).

All V_{DD_V} pins must be powered on at the same time or before VDD_XO is powered on

The sequence applies for configuration loading from EEPROM and from the internal storage.

Automatic Startup and Self-Configuration

At startup, an internal power-on reset (POR) resets the device. The internal POR starts 20ms after the supply pin VDD_XO is powered up.

After reset:

1. The device detects the presence of an external EEPROM attached to the serial control Port I²C (SDA_M and SCL_M pins). This serial port is in master mode.
 - If an EEPROM is found, the device attempts to load a configuration from it, overwriting the values in the device registers with the content of the EEPROM (an EEPROM load does not change the GPIO configuration in registers 0x0300-0x0303).
 - If the device does not detect an EEPROM, or EEPROM loading not successful (bad checksum error): the device will load one default configuration from internal storage, specified by the GPIO[1:0] pin state. In each of the default configurations, the QCLK_y, QCLK_d, QREF_r_outputs are enabled/disabled at startup as defined in [Table 31](#).

After configuration loading:

1. The device calibrates the APLLs that were enabled (powered-up) in the configuration load.
2. The device waits for 1ms to allow the enabled APLLs to lock.
3. The device will then continue the startup process by an internal divider reset procedure that aligns all dividers and makes them deterministic.
4. As a last step, the device asserts the READY signal on the GPIO3 pin to indicate that the device initialization is complete (the READY signal is a copy of [DEVICE_RDY_STS](#) bit). After READY/[DEVICE_RDY_STS](#) is asserted, the user can access any device register for configuration changes through the serial interfaces.

Table 31. Default Startup Configurations

Input or Output or Block	Setting or Parameter	GPIO[1:0] Pins at Startup Configuration Name			
		00 Configuration 0	01 Configuration 1	10 Configuration 2	11 Configuration 3
Inputs and external oscillators	CLK_0	Disabled	Disabled, 1.92MHz	Enabled, 156.25MHz	Enabled, 15.36MHz
	CLK_1	Disabled	Disabled, 0.96MHz	Enabled, 156.25MHz	Enabled, 15.36MHz
	OSCI, OSCO pins	None	48MHz	48MHz (TCXO)	Not selected, 52MHz
	XO/TCXO/OSCO on XO_DPLL, nXO_DPLL	48MHz	None	None	38.4MHz
SYS-APLL	Signal source	XO_DPLL	OSCI		XO_DPLL
Input Monitors	CLK_0	ST = 1 cycle MT = 1.25ms LT = 10s	ST = 1 cycle MT = 1.25ms LT = 10s (masked)	ST = 4 cycles MT = 1.25ms LT = 10s (masked)	ST = 2 cycles MT = 1.25ms LT = 10s (masked)
	CLK_1	ST = 1 cycle MT = 1.25ms LT = 10s	ST = 1 cycle MT = 1.25ms LT = 10s (masked)	ST = 4 cycles MT = 1.25ms LT = 10s (masked)	ST = 2 cycles MT = 1.25ms LT = 10s (masked)

Table 31. Default Startup Configurations (Cont.)

Input or Output or Block	Setting or Parameter	GPIO[1:0] Pins at Startup Configuration Name			
		00 Configuration 0	01 Configuration 1	10 Configuration 2	11 Configuration 3
DPLL-0	PLL bandwidth	0.992Hz		1.24Hz	1.985Hz
	Phase Slope Limit	15x10e6 ns/s	1000 ns/s	7.5us/s	15x10e6 ns/s
	APLL-0 frequency	2450-2580MHz			
	Signal source	Manual selection (CLK_1 (disabled))		Automatic (CLK_0)	GPIO selection (CLK_1)
	Combo Source	None			
DPLL-1	PLL bandwidth	0.992Hz		93mHz	1.985Hz
	Phase Slope Limit	15x10e6 ns/s	1000 ns/s	Bypassed	15x10e6 ns/s
	APLL-1 frequency	3932.16MHz			
	Signal source	Manual selection (CLK_1 (disabled))		Write Phase Mode ^a	GPIO selection (CLK_1)
	Combo Source	None		DPLL-0	None
APLL-2	Enable/disable	Disabled		Enabled	
	Used as SYS-DPLL	No			
	PLL bandwidth	Not used		182kHz	
	APLL-2 frequency	Not used		3750MHz	
	Signal source	Not used		DPLL-1	
RF-PLL	Enable/disable	Enabled			
	PLL bandwidth	220kHz		110kHz	
	VCO frequency	2949.12MHz			
	Charge pump current		2.2mA		
	Signal source	DPLL-1			
QCLK_D0	Frequency	50MHz	100MHz	156.25MHz	125MHz
	Output Style	LVC MOS	LVDS		LVPECL
	Signal	3.3V	VOD = 500mV, VOS bit not set		500mV
	VDDO	3.3V	2.5V		3.3V
	Power up/down	Up			
	Enable/Disable	Enabled			
	Signal Source	DPLL-0			
	Phase Alignment	All QCLK_D_y		QCLK_D1	All QCLK_D_y
nQCLK_D0	Power up/down	Down	n/a		

Table 31. Default Startup Configurations (Cont.)

Input or Output or Block	Setting or Parameter	GPIO[1:0] Pins at Startup Configuration Name			
		00 Configuration 0	01 Configuration 1	10 Configuration 2	11 Configuration 3
QCLK_D1, nQCLK_D1	Frequency	125MHz	100MHz	156.25MHz	50MHz
	Output Style	LVDS			LVPECL
	Signal	VOD = 500mV, VOS bit not set			Amplitude = 500mV
	VDDO	2.5V			3.3V
	Power up/down	Up			
	Enable/Disable	Enabled			
	Signal Source	DPLL-0			
	Phase Alignment	All QCLK_D_y		QCLK_D0	All QCLK_D_y
QCLK_D2, nQCLK_D2	Frequency	312.5MHz		250MHz	187.5MHz
	Output Style	LVDS			
	Signal	VOD = 500mV, VOS bit not set		VOD = 350mV, VOS = 1.25V	
	VDDO	2.5V		3.3V	
	Power up/down	Up			Down
	Enable/Disable	Enabled			Disabled
	Signal Source	DPLL-0		DPLL-1 through APLL-2	
	Phase Alignment	All QCLK_D_y		QCLK_D3	All QCLK_D_y
QCLK_D3	Frequency	100MHz	312.5MHz	1PPS	156.25MHz
	Output Style	LVDS		LVC MOS	LVPECL
	Signal	VOD = 500mV, VOS bit not set		3.3V	500mV
	VDDO	2.5V		3.3V	
	Power up/down	Up			
	Enable/Disable	Enabled			
	Signal Source	DPLL-0		DPLL-1 through APLL-2	
	Phase Alignment	All QCLK_D_y		QCLK_D2	All QCLK_D_y
nQCLK_D3	Power up/down	n/a		Down	n/a

Table 31. Default Startup Configurations (Cont.)

Input or Output or Block	Setting or Parameter	GPIO[1:0] Pins at Startup Configuration Name			
		00 Configuration 0	01 Configuration 1	10 Configuration 2	11 Configuration 3
QCLK_R0, nQCLK_R0	Frequency	491.52MHz		245.76MHz	122.88MHz
	Output Style	LVDS			
	Signal	VOD = 500mV, VOS bit not set			VOD = 350mV, VOS = 1.25V
	VDDO	2.5V			3.3V
	Power up/down	Up			Down
	Enable/Disable	Enabled			
	Signal Source	RF-PLL			
	Phase Alignment	All QCLK_y			
QCLK_R1, nQCLK_R1; QCLK_R4, nQCLK_R4	Frequency	491.52MHz		245.76MHz	122.88MHz
	Output Style	LVDS			LVPECL
	Signal	VOD = 500mV, VOS bit not set			750mV amplitude
	VDDO	2.5V			3.3V
	Power up/down	Up			
	Enable/Disable	Enabled			
	Signal Source	RF-PLL			
	Phase Alignment	All QCLK_y			
QCLK_R2, nQCLK_R2; QCLK_R3, nQCLK_R3	Frequency	491.52MHz		245.76MHz	122.88MHz
	Output Style	LVDS			LVPECL
	Signal	VOD = 500mV, VOS bit not set			500mV amplitude
	VDDO	2.5V			3.3V
	Power up/down	Up			
	Enable/Disable	Enabled			
	Signal Source	RF-PLL			
	Phase Alignment	All QCLK_y			

Table 31. Default Startup Configurations (Cont.)

Input or Output or Block	Setting or Parameter	GPIO[1:0] Pins at Startup Configuration Name			
		00 Configuration 0	01 Configuration 1	10 Configuration 2	11 Configuration 3
QCLK_R5, nQCLKR5	Frequency	122.88MHz			
	Output Style	LVDS		LVPECL	
	Signal	VOD = 500mV, VOS bit not set		750mV amplitude	
	VDDO	2.5V		3.3V	
	Power up/down	Up			
	Enable/Disable	Enabled			
	Signal Source	RF-PLL			
	Phase Alignment	All QCLK_y			
QREF_R0, nQREF_R0, QREF_R4, nQREF_R4	Frequency	n/a	7.68MHz		
	Output Style	n/a	LVDS		
	Signal	n/a		VOD = 350mV, VOS = 1.25V	
	VDDO	2.5V		3.3V	
	Power up/down	Power down			
	Enable/Disable	n/a		Enabled	
	Signal Source	RF-PLL			
	Phase Alignment	n/a		All QREF_Ry	
QREF_R1, nQREF_R1; QREF_R2, nQREF_R2; QREF_R3, nQREF_R3; QREF_R5, nQREF_R5	Frequency	n/a	7.68MHz		
	Output Style	n/a	LVDS		
	Signal	n/a		VOD = 350mV, VOS = 1.25V	
	VDDO	2.5V		3.3V	
	Power up/down	Power down		Power up	
	Enable/Disable	n/a		Enabled	
	Signal Source	RF-PLL			
	Phase Alignment	n/a		All QREF_Ry	

Table 31. Default Startup Configurations (Cont.)

Input or Output or Block	Setting or Parameter	GPIO[1:0] Pins at Startup Configuration Name			
		00 Configuration 0	01 Configuration 1	10 Configuration 2	11 Configuration 3
GPIOs	GPIO_0	Input, select startup configuration	Input, select startup configuration; after startup: select DPLL-0 input - selection is set to manual (register)	Input, select startup configuration	Input, select startup configuration; after startup: select DPLL-0 input
	GPIO_1		Input, select startup configuration; after startup: selection is set to manual (register)		Input, select startup configuration; after startup: select DPLL-1 input
	GPIO_2	Output: APLL-0 lock detect status		Output: DPLL-0 lock detect status	Output: DPLL-1 lock detect status
	GPIO_3	Output: device ready status			

a. DPLL-1 state will start in acq1 due to being in write phase mode.

Recommended Initialization Sequence (Manual Configuration)

This section describes the device initialization through the serial interfaces. It is not applicable when the device is auto-configured by an internally-stored configuration as described in [Automatic Startup and Self-Configuration](#).

Recommended manual configuration sequence (in order):

1. Configure the DPLLs and APLLs, frequency divider, and delay circuits as well as other device settings through a serial interface.
2. Run the calibration routine for all four internal VCOs by setting the relock bit RELOCK in register 0x0320 (there are internal enable bits for each VCO to participate in calibration).
3. Reset the DPLL_RST bit in register 0x0011 (set bit to 1).
4. Initialize divider state machines and output phase delay circuits by writing in order:
 - [INIT_CLK_A](#), [INIT_CLK_B](#), [INIT_CLK_C](#), [INIT_CLK_D](#) (synchronizes the frequency dividers). It is necessary to wait up to 500µs between each write on these bits for each initialization to be complete before proceeding to write the next INT_CLKx bit. These bits will self clear. It is recommended to read the status register located at register 0x0317 to ensure PLL calibration and all synchronizations of the frequency dividers have been completed successfully.
 - [INIT_REF](#) (synchronizes the SYSREF frequency dividers). This bit will self clear.
5. Release the DPLL_RST bit in register 0x0011 (reset bit 0). This bit was set in step 3 and now releases the DPLLs which will then attempt to lock to the selected reference.
6. Clear all status flags.
7. Enable the outputs as desired for normal operation by using the output-enable registers in a separate serial interface write access.

Recommended Initialization Sequence (EEPROM Load)

This section describes the device initialization through the reading of an external EEPROM for configuration. Loading from EEPROM automates multiple steps necessary in manual configuration. This section is not applicable when the device is auto-configured by an internally-stored configuration as described in [Automatic Startup and Self-Configuration](#).

Recommended EEPROM load configuration sequence (in order):

1. Configure the DPLLs, APLLs, frequency divider, reference monitors, input selection, delay circuits, output settings including output enable by an EEPROM image.
2. The image is loaded by the device when a valid EEPROM device is auto-detected (EEPROM attached to the master I2C serial control port I²C, SDA_M, and SCL_M pins). The EEPROM load state machine will run the VCO calibration routine for all APLLs, and initialize and synchronize (align) the divider state machines output phase delay circuits.
3. Completion of step 2 is indicated by the device by asserting the [DEVICE_RDY_STS](#) register bit and asserting GPIO_3 (READY). Outputs set to “enable” in the EEPROM image are now enabled.
4. Set INIT_REF (synchronizes the SYSREF frequency dividers) if desired for using the SYSREF function. This bit will self clear.
5. Clear all status flags.
6. Enable the outputs (if not already enabled in step 1) for normal operation by using the output-enable registers in a separate SPI or I2C write access.

Serial Port Description

The device has a pin-mapped SPI/I3C serial interface for device configuration and continues update of device registers (e.g., in a IEEE1588 application to write phase or frequency offsets into the DPLLs). The pin SPI_SEL selects the active interface. The I3C interface (when selected) supports legacy I²C operation and SDR mode only. The purpose of the additional I²C master interface is to connect an external EEPROM for reading configuration information at startup. The I²C master interface is independent of the pin mapped SPI/I3C interface.

Table 32. Serial Interface Selection^{a b c}

SPI_SEL	Operation
0	I3C: pins 74 (SCL), 75 (SDA)
1 (default)	SPI: pins 73 (nCS), 74 (SCLK), 75 (SDO), 76 (SDI)

- a. The I²C master interface at pins 78 (SCL_M) and 79 (SDA_M) is not affected by SPI_SEL.
- b. SPI_SEL should not be changed in serial interface operation to prevent data corruption. It is recommended to leave SPI_SEL in a static state and not change the interface type after power-up.
- c. SYS-APLL must be locked before any serial port access.

SPI Interface (SPI_SEL = 1)

The device has a 4-wire serial control port capable of responding as a slave in an SPI configuration to allow DCO phase updates and to read and write access to any of the internal registers for device programming or read back. A 3-wire serial control port can be selected via [SDO_ACT](#).

The SPI interface consists of the SCLK (clock), SDI (serial data input), SDO (serial data output), and nCS (chip select) pins. A data transfer contains 16 bits (direction + 15 bit address) and any integer multiple of 8 bits (input or output data), and is always initiated by the SPI master on the bus. Internal register data is organized in SPI bytes of 8 bits each. The device supports most-significant bit (MSBit) and least-significant (LSBit) first transfer bit positions, single-byte and multi-byte data streaming modes with address auto-increment and auto-decrement. For SPI logic diagrams, see [Figure 18](#) to [Figure 21](#). For the SPI timing diagrams, see [Figure 24](#) and [Table 142](#).

Chip Select. If the nCS pin is at logic high, the SDO data output pin is in high-impedance state and the SPI interface of the device is disabled.

Active Clock Edge. In a write operation, data on SDI will be clocked in on the rising edge of SCLK. In a read operation, data on SDO will be clocked out on the falling or rising edge of SCLK depending on the CPOL setting (CPOL = 0: output data changes on the falling edge, CPOL = 1: output data changes on the rising edge).

Least Significant Bit Position. The device supports LSBit (least significant bit first) and MSBit (most significant bit first) transfers between master and slave. If MSBit first is set, data is transferred in this order: transfer direction bit first, then the register address bits A14 to A0, then the data bits of the first data byte D7 to D0. If LSBit first is set, the order is: address bits A0 to A14 first, then the transfer direction bit, then the data bits of the first data byte D0 to D7.

Starting a data transfer requires the nCS pin to set and hold at logic low level during the entire transfer. Setting nCS = 0 will enable the SPI interface and SDI accepts data. The master must initiate the first 16-bit transfer containing the transfer direction bit and the SPI register address to access.

Transfer Direction Bit: Defines if the master reads data from the device or writes data to the device. R/nW (1 = Read, 0 = Write). If MSB-first is set, the transfer bit is presented by the master as the first bit in the transfer. If LSB-first is set, the transfer bit is the 16th bit presented by the master. MSB-first is the default upon power-up: the initial data transfer must be in MSB-first order.

Address: The device supports a 15-bit address A[14:0] pointing to an internal register in the address space 0 to 0x7FFF.

Read operation from an internal register: a read operation starts with a 16-bit transfer from the master to the slave: the SDI signal is clocked on the *rising* edge of SCLK. The transfer direction bit R/nW must be to 1 to indicate a read transfer, the other 15 bits is the address A[14:0] to read from. After the first 16 bits are clocked into the SDI pin, the SDO pin is enabled to output data. The register content addressed by A[14:0] are the presented at the SDO output at the next 8 SCLK *falling* (CPOL = 1) or next eight SCLK *rising* (CPOL = 1) clock cycles and transfer these to the master. Transfers must be completed with de-asserting nCS after any multiple eight of SCLK cycles. If nCS is de-asserted at any other number of SCLKs, the SPI behavior is undefined. Read operation transfers multiple bytes in streaming mode with the 15-bit register address auto-increment or decrement. Single-byte transfers are supported in streaming mode by de-asserting nCS after the first payload byte.

Write operation to a device register: During a write transfer, an SPI master transfers one or more bytes of data into the internal registers of the device. A write transfer starts by asserting the nCS to pin low logic level. The transfer direction bit R/nW must be set to 0 to indicate a write transfer; the other 15 bits are the address A[14:0] to write to. Bits D[7:0] contain 8 bits of transfer data, which are written into the register specified by A[14:0] at the end of each 8-bit write transfer. Multiple, subsequent register transfers from the master to the slave are supported in streaming mode by holding nCS asserted at logic low level during write transfers. Transfers must be completed with de-asserting nCS after any multiple of eight SCLK cycles. If nCS is de-asserted at any other number of SCLKs, the SPI behavior is undefined. The 15-bit register address will auto-increment or decrement (streaming mode). Single-byte transfers are supported in streaming mode by de-asserting nCS after the first payload byte.

Register Streaming Mode. Streaming mode is the transfer of multiple data bytes back-to-back. The address A[14:0] specifies the register location of the first byte to transfer, for the following transfer, the address is automatically incremented or decremented. nCS must stay at logic low level and the SDO pin will present multiple registers, e.g. (A), (A -1), (A -2), with each eight SCLK cycles. During SPI Read operations, the user may continue to hold nCS low and provide further bytes. The ASC_ON register defines if registers auto-increment (A), (A +1), (A +2), etc. or auto-decrement (A), (A -1), (A -2), etc.

Address wrap-around: Applicable to streaming mode: The address will wrap around the address range of 0x00 – 0x7FF. The SPI engine auto-increments to address 0x00 after 0x7FF and auto-decrements to address 0x7FF after 0x00.

End of transfer: After nCS is de-asserted to logic 1, the SPI bus is available to transfers to other slaves on the SPI bus. The READ diagrams (Figure 19, Figure 20, and Figure 21) and WRITE diagram (Figure 18) display the transfer of a single byte of data from and into registers.

Multi-byte Registers. PLL divider registers that are wider than 8 bits are effective after the last byte is written.

Internal Debug Registers. Registers in the address range 0x328 to 0x339 should not be used. Do not write into any registers within this address range.

Default SPI Modes: After power-up the SPI interface is in MSB-first mode, streaming mode on with address auto-decrement. In read transfer mode, data is output on SDO on the falling SCLK edge.

Figure 18. Logic Diagram: Single Byte WRITE Data into Device Registers in SPI 3 or 4-wire Mode for LSB and MSB-First

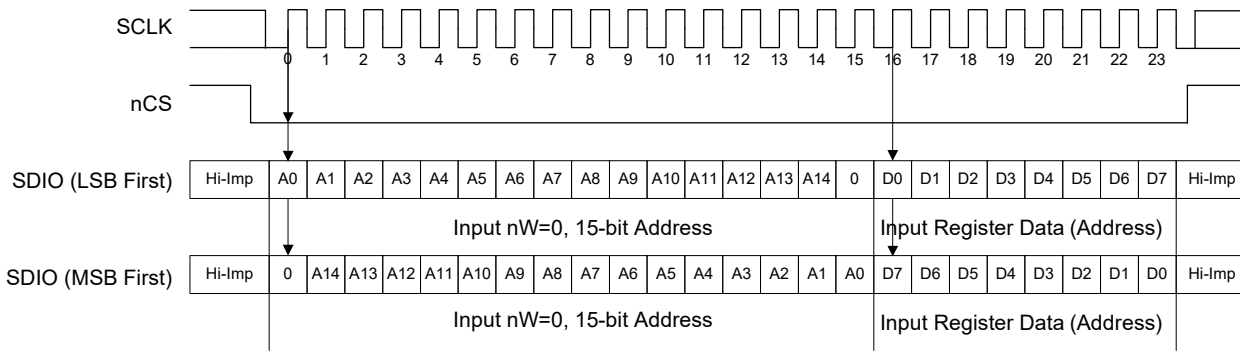

Figure 19. Logic Diagram: Single Byte READ Data from the Device Registers in SPI 3-wire Mode for LSB and MSB-First and CPOL = 0, 1

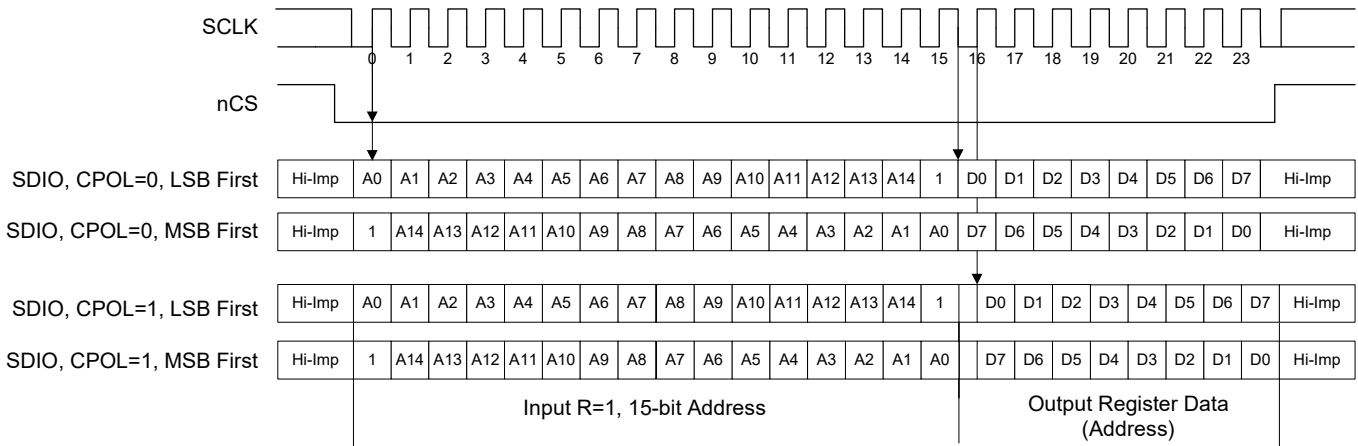

Figure 20. Logic Diagram: Single Byte READ Data from the Device Registers in SPI 4-wire Mode for LSB-First and CPOL = 0, 1

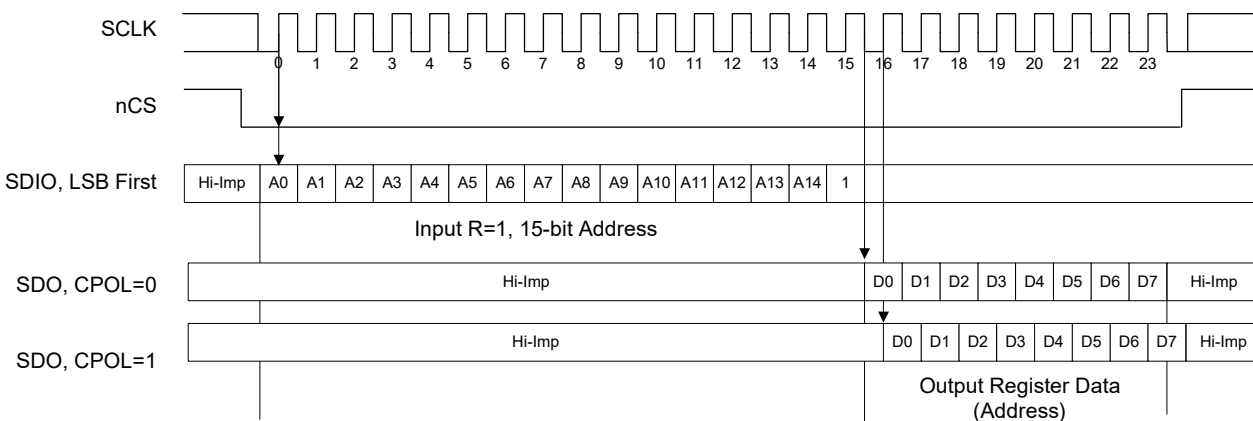
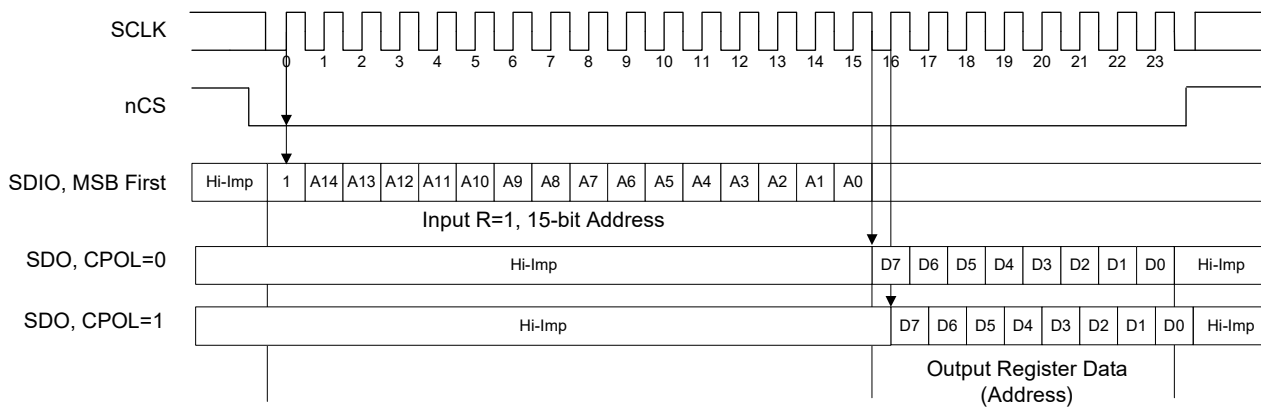

Figure 21. Logic Diagram: Single Byte READ Data from the Device Registers in SPI 4-wire Mode for MSB-First and CPOL = 0, 1



I3C Interface (SPI_SEL = 0)

Supported I3C Operations

The 8V19N850 supports a subset of the MIPI I3C v1.0 protocol:

- Single data rate (SDR) mode only. HDR modes are not supported
- Legacy I²C mode
- I3C clock frequencies (SCL pin) according to [Table 143](#)
- Static addressing mode with support for up to four 8V19N850 devices on the same I3C bus
- Dynamic addressing mode
- In-band interrupt

Legacy I²C

In legacy I²C mode the device uses the static 7-bit address.

Static Address Mode

The legacy I²C and static I3C 7-bit address is 0b11010[ADR1][ADR0], where address bit ADR1 is set by the state of pin 73 (pin name: SDI/ADR1) and bit ADR0 is set by pin 76 (pin name: nCS/ADR0). Applications employing static addressing where the ADR[1:0] bits are hardwired to preset address based on the part's location on the circuit board. A total of four devices can be included on any I3C bus using static addressing. To establish one of four static addresses, connect ADR[1:0] as show in [Table 33](#). Changing the state of the SDI/ADR1 and nCS/ADR0 pins during device operation will result in a change of the static address and is not recommended to prevent data corruption.

Table 33. Static Address

8V19N850 Slave	Preset Address Bits					Configurable Address Bits		Full Address
	A6	A5	A4	A3	A2	A1 (SDI/ADR1)	A0 (nCS/ADR0)	
0	1	1	0	1	0	0	0	0x68
1							1	0x69
2						1	0	0x6A
3							1	0x6B

Dynamic Address Mode

IC3 masters must assign a dynamic address to the device after startup. The I3C interface has a 48-bit provisional ID for the dynamic addressing mode (see Table 34). The state of the device pins 73 (pin name: SDI/ADR1) and 76 (pin name: nCS/ADR0) are part of the I3C 48-bit provisional ID. Changing the state of the SDI/ADR1 and nCS/ADR0 pins during device operation will result in a change of the provisional ID and is not recommended in order to prevent data corruption.

Table 34. I3C 48-Bit Provisional ID

8V19N850 Slave	MIPI Manufacturer ID	Provisional ID Type Selector	Part ID	Instance ID 4 Bits ^a			12 Bits
	[47:33]	[32]	[31:16]	[15:14]	[13] (SDI/ADR1)	[12] (nCS/ADR0)	[11:0]
0	15'h0222	1'b0 ^b	16'h43	2'b10	0	0	12'h6
1						1	
2					1	0	
3						1	

- a. The lower two bits of the 4-bit Instance ID bit field are set by the state of the pins 73 (pin name: SDI/ADR1) and pin 76 (pin name: nCS/ADR0).
- b. Fixed vendor value, specified in Part ID bits [31:16]

For the I3C timing specification, see Table 143 and Figure 25 - Figure 27.

I²C Master Interface

Capabilities

The 8V19N850 can become a master on the dedicated I²C interface (pins 78 SCL_M and 79 SDA_M) bus only for the purpose of reading its initial register configurations from a serial EEPROM on the I²C bus. Writing of the configuration to the serial EEPROM must be performed by another device on the same I²C bus or pre-programmed into the device prior to assembly. The 8V19N850 can become a bus master on the I²C bus for the purposes of reading its configuration from an external I²C EEPROM. Only a block read cycle will be supported.

As an I²C bus master, the 8V19N850 will support the following functions:

- 7-bit addressing mode
- Base address register for EEPROM
- Validation of the read block via CCITT-8 CRC check against value stored in last byte (0x0339) of the EEPROM
- Support for 100kHz operation
- Support for 2-byte addressing mode
- Master arbitration with programmable number of retries
- Fixed-period cycle response timer to prevent permanently hanging the I²C bus
- Read will abort with an alarm if any of the following conditions occur: Slave NACK, Arbitration Fail, Collision during Address Phase, CRC failure, or Slave Response time-out

The 8V19N850 will not support the following functions:

- I²C General Call
- Slave clock stretching
- I²C Start Byte protocol
- EEPROM Chaining
- CBUS compatibility
- Responding to its own slave address when acting as a master
- Writing to external I²C devices including the external EEPROM used for booting

I2C Address for EEPROM

Table 35. I2C EEPROM Address

1	0	1	0	0	0	0	R/W
MSB							LSB

Operation

The 8V19N850 attempts to read from EEPROM after completion of the internal power-up by detecting the presence of the EEPROM. If the detection was successful, the device will contend for ownership of the I²C bus to read its initial register settings from a memory location on the I²C bus. During the boot-up process, the device will not respond to serial control port accesses. Once the initialization process is complete, the contents of any of the device's registers can be altered. If the detection of an EEPROM was not successful, the device will read a default configuration from one of the four read-only storage spaces that is specified by the GPIO pins 0, 1.

During the EEPROM load, the 8V19N850 will load the EEPROM content of registers 0x0000 - 0x0327 and 0x0337 into the device's registers at addresses 0x0000 - 0x0337; data located at address A in the EEPROM will be placed at the same address A in the 8V19N850. Data from addresses 0x0300-0x0303 are not copied from the EEPROM to the device.

The EEPROM Checksum (CRC) is also stored as a read only register at address 0x0339 and can be read via SPI or I3C after an EEPROM load has completed. If a NACK is received to any of the read cycles performed by the device during the initialization process, or if the CRC does not match the one stored in address 0x0339 of the EEPROM, the process will be aborted and the device will read its register configuration from the internal ROM based on the state of the GPIO[1:0] pins. The RD_EEPROM_ABORT_STS and CHK_SUM_ERR_STS bits in the Read EEPROM Status register (0x0012) will also be set in these events, respectively. During EEPROM loading, the internal access to registers through the SPI/I3C port is not possible..

Table 36. External Serial EEPROM Contents

EEPROM Offset (Hex)	Contents							
	D7	D6	D5	D4	D3	D2	D1	D0
0x0000	Desired content for device register 0x0000							
0x0001	Desired content for device register 0x0001							
...	...							
0x0007	EEPROM version (EEPROM_VER1), optional to use							
0x0008	EEPROM version (EEPROM_VER0), optional to use							
...	...							
0x0327	Desired content for device register 0x0327							
0x0337	EEPROM version							
0x0339	EEPROM Checksum							

Figure 22. Master I²C Initialization Mode



Configuration and Status Registers

Registers labeled “Reserved” should not be modified. Always write zero (0) to reserved registers and reserved register bits if a register write to a register with reserved bits is required. All addresses without description are reserved.

General Device Configuration

Bits [3:0] should always mirror [7:4] so that it does not matter whether the part is in MSB or LSB first mode (see Register 0x00 Bit [6]). Note: It will take effect only with high bit and relative mirror bit with same value. Otherwise, it cannot take effect if high bit does not have the same value as the lower mirror bit.

Table 37. General Device Configuration Locations and Descriptions

Address	D7	D6	D5	D4	D3	D2	D1	D0
0x0000	SRESET	LSB_1ST	ACS_ON	SDO_ACT	SDO_ACT_MIRROR	ACS_ON_MIRROR	LSB_1ST_MIRROR	SRESET_MIRROR
0x0001	Reserved							CPOL
0x0002	Reserved							
0x0003	DEV_TYPE[7:0]							
0x0004	DEV_ID[7:0]							
0x0005	DEV_ID[15:8]							
0x0006	DEV_VER[7:0]							
0x0007	EEPROM_VER1[7:0]							
0x0008	EEPROM_VER0[7:0]							
0x000C	VENDOR_ID[15:8]							
0x000D	VENDOR_ID[7:0]							

Table 38. General Device Configuration Locations and Descriptions

Bit Field Name	Field Type	Default Value	Description
SRESET SRESET_MIRROR	R/W R/W	0 0	Soft Reset (self-clearing) 0 = Normal operation. 1 = Register reset. The device loads the default values into the registers 0x002-0x336 and 0x338. The content of the register addresses 0x00 and 0x01 and the SPI engine are not reset. SRESET bit D7 is mirrored with SRESET_MIRROR in bit position D0. Register reset requires to set both SRESET and SRESET_MIRROR bits.
LSB_1ST LSB_1ST_MIRROR	R/W R/W	0 0	Least Significant Bit Position: Defines the bit transmitted first in SPI transfers between slave and master. 0 = The most significant bit (D7) first 1 = The least significant bit (D0) first When set to 1, it causes input and output data to be oriented as LSB first. If this bit is clear, data is oriented as MSB first. LSBIT_1ST bit D6 is mirrored with LSBIT_1ST_MIRROR in bit position D1. Changing LSBIT_1ST to most significant bit requires to set both LSBIT_1ST and LSBIT_1ST_MIRROR bits.

Table 38. General Device Configuration Locations and Descriptions

Bit Field Name	Field Type	Default Value	Description
ACS_ON ACS_ON_MIRROR	R/W R/W	0 0	Address Ascend on 0 = Address ascend is off (addresses auto-decrement) 1 = Address ascend is on (addresses auto-increment) The ASC_ON bit specifies whether addresses are incremented or decremented in streaming SPI transfers. ASC_ON bit D5 is mirrored with ASC_ON in bit position D2. Changing ASC_ON to "ON" requires to set both ASC_ON and ASC_ON_MIRROR bits.
SDO_ACT SDO_ACT_MIRROR	R/W R/W	1 1	SPI 3/4 Wire Mode Selects the unidirectional or bidirectional data transfer mode for the SDIO pin. 0 = SPI 3-wire mode: – SDIO is the SPI bidirectional data I/O pin – SDO pin is not used and is in high-impedance 1 = SPI 4-wire mode – SDIO is the SPI data input pin – SDO is the SPI data output pin SDO_ACT bit D4 is mirrored with SDO_ACT_MIRROR in bit position D3. Changing SDO_ACT to SPI 4-wire mode requires to set both SDO_ACT and SDO_ACT_MIRROR bits.
CPOL	R/W	0	Read Operation SCLK Polarity 0 = Data bits on SDAT are output at the falling edge of SCLK edge (SPI master will capture data on the rising edge of SCLK) 1 = Data bits on SDAT are output at the rising edge of SCLK edge (SPI master will capture data on the falling edge of SCLK)
Reserved	R/W	0	Reserved. Do not modify this value.
DEV_TYPE[7:0]	R/O	0110b	Device type: set to 0x06: Device is a PLL
DEV_ID[15:0]	R/O	0x0043	Device Identifier = 0x43
DEV_VER[7:0]	R/O	3	Device Version = 0x03
EEPROM_VER1[7:0]	R/W	-	These bytes are copied from an external EEPROM from the same offset address and can be used as EEPROM version information. Both EEPROM_VER0,1 registers should not be overwritten by a serial interface write access. Bytes are reserved if the device is not auto-configured from an EEPROM.
EEPROM_VER0[7:0]	R/W	-	
VENDOR_ID[15:0]	R/O	0x0426	Vendor Identifier: 0x0426 (Renesas/IDT). Reads 0x0426 (Renesas/IDT) after power-up and reset.

General Power Down Registers

Table 39. General Power Down Bit Field Locations and Descriptions

Address	D7	D6	D5	D4	D3	D2	D1	D0
0x0011	Reserved		SYSAPLL_PWN	SYSDPLL_PWN	DPLL1_PWN	DPLL0_PWN	DPLL_RST	DPLL_UPDATE_RATE

Table 40. General Power Down Bit Field Locations

Bit Field Name	Field Type	Default Value	Description
Reserved	R/W	0	Reserved. Do not modify this value.
SYSDPLL_PWN	R/W	0	System DPLL power down 0 = SYS-DPLL is powered on 1 = SYS-DPLL is powered down
DPLL1_PWN	R/W	0	DPLL-1 power down 0 = DPLL-1 is powered on 1 = DPLL-1 is powered down
DPLL0_PWN	R/W	0	DPLL-0 power down 0 = DPLL-0 is powered on 1 = DPLL-0 is powered down
DPLL_RST	R/W	0	Reset the functional blocks REF_MON0, REF_MON1 (reference monitors for inputs CLK_0 and CLK_1), SYS-DPLL, DPLL-0, DPLL-1 including the DPLL-0/1 fractional feedback dividers. 0 = Normal operation 1 = Reset
DPLL_UPDATE_RATE	R/W	0	Reserved
SYSAPLL_PWN	R/W	0	System APLL power down 0 = SYS-APLL is powered on 1 = SYS-APLL is powered down System APLL can be powered down if the device does not use input clock signals at CLK_0 and CLK_1, and DPLL-0 and DPLL_1 are used as DCOs. When the SYS-APLL is powered down, the internal system clocks for the serial interfaces are automatically derived from VCO-0 or VCO-1.

Read EEPROM Status

Table 41. Read EEPROM Status Bit Field Locations

Address	D7	D6	D5	D4	D3	D2	D1	D0
0x0012	Reserved		CHK_SUM_ERR_STS	RD_EEPROM_ABORT_STS	RD_EEPROM_ACTIVE_STS	DEVICE_RDY_STS	RD_EEPROM_RELOCK_INIT_DONE_STS	RD_EEPROM_DONE_STS

Table 42. Read EEPROM Status Bit Field Descriptions

Bit Field Name	Field Type	Default Value	Description
CHK_SUM_ERR_STS	R/O	0	Check sum error reading EEPROM 0 = Check sum pass 1 = Check sum fail
RD_EEPROM_ABORT_STS	R/O	0	1 = Indicates EEPROM read aborted because I2C master lost bus access or EEPROM did not respond
RD_EEPROM_ACTIVE_STS	R/O	0	1 = Indicates reading from EEPROM is in progress
DEVICE_RDY_STS	R/O	0	1 = Indicates device has finished initialization
RD_EEPROM_RELOCK_INIT_DONE_STS	R/O	0	1 = Indicates reading from EEPROM, relock, and asserting INIT_CLK_A/B/C/D is completed
RD_EEPROM_DONE_STS	R/O	0	1 = Indicates reading from EEPROM is completed

I/O Voltage Select Configuration

Table 43. I/O Voltage Select Configuration Bit Field Locations

Address	D7	D6	D5	D4	D3	D2	D1	D0
0x0013	Reserved					SELSV2	SELSV1	SELSV0

Table 44. I/O Voltage Select Configuration Bit Field Descriptions

Bit Field Name	Field Type	Default Value	Description
SELSV2	R/W	0	This bit configures GPIO I/O to be compatible with 1.8V or 3.3V 0 = Compatible with 1.8V 1 = Compatible with 3.3V
SELSV1	R/W	0	Reserved
SELSV0	R/W	0	This bit configures SDI (SPI data OUTPUT ONLY) and SDO_SDA (as SPI SDO output only) to be compatible with 1.8V or 3.3V. 0 = Compatible with 1.8V 1 = Compatible with 3.3V

System APLL (SYS-APLL) Configuration

Table 45. SYS-APLL Configuration Bit Field Locations

Address	D7	D6	D5	D4	D3	D2	D1	D0
0x0020	Reserved			Reserved				
0x0021	Reserved			Reserved				
0x0022	Reserved		Reserved		Reserved		Reserved	
0x0023	M_INT_SA[7:0]							
0x0024	M_NUM_SA[7:0]							
0x0025	M_NUM_SA[15:8]							
0x0028	M_DEN_SA[7:0]							
0x0029	M_DEN_SA[15:8]							
0x002C	Reserved	Reserved			Reserved		Reserved	Reserved
0x002D	Reserved							
0x002E	Reserved							
0x002F	Reserved							

Table 46. SYS-APLL Configuration Bit Field Descriptions

Bit Field Name	Field Type	Default Value	Description
M_INT_SA[7:0]	R/W	0x24	Integer portion of the SYS-APLL fractional feedback divider (binary coding)
M_NUM_SA[15:0]	R/W	0	Numerator portion of the SYS-APLL fractional feedback divider (binary coding)
M_DEN_SA[15:0]	R/W	0x8000	Denominator portion of the SYS-APLL fractional feedback divider (binary coding)

System DPLL (SYS-DPLL) Configuration

Table 47. SYS-DPLL State Bit Field Locations

Offset Address	D7	D6	D5	D4	D3	D2	D1	D0
0x0044	SYSDPLL_TDC_FB[1:0]		Reserved			DPLL_STATE_SYSDPLL_CNFG[2:0]		
0x0046	Reserved				LOCK_STS_SYSDPLL	DPLL_STATE_STS_SYSDPLL[2:0]		
0x0047	FILTER_STS_SYSDPLL[7:0]							
0x0048	FILTER_STS_SYSDPLL[15:8]							
0x0049	FILTER_STS_SYSDPLL[23:16]							
0x004A	FILTER_STS_SYSDPLL[31:24]							
0x004B	FILTER_STS_SYSDPLL[39:32]							
0x004C	FILTER_STS_SYSDPLL[47:40]							
0x004D	PHASE_STS_SYSDPLL[7:0]							
0x004E	PHASE_STS_SYSDPLL[15:8]							
0x004F	PHASE_STS_SYSDPLL[23:16]							
0x0050	PHASE_STS_SYSDPLL[31:24]							
0x0051	Reserved				PHASE_STS_SYSDPLL[35:32]			

Table 48. SYS-DPLL State Bit Field Descriptions

Bit Field Name	Field Type	Default Value	Description
SYSDPLL_TDC_FB[1:0]	R/W	00	SYSDPLL TDC feedback control 00/11 = SYS-DPLL feedback 01 = CLK_0 10 = CLK_1
DPLL_STATE_SYSDPLL_CNFG[2:0]	R/W	000	State of the SYS-DPLL 000 = Freerun 001 = Lock acquisition 010 = Normal lock 011 = Holdover 100 = Lock recovery 101 = Auto cnfg
LOCK_STS_SYSDPLL	R/O	0	SYS-DPLL lock status 0 = Unlocked 1 = Locked
DPLL_STATE_STS_SYSDPLL[2:0]	R/O	000	SYS-DPLL states: 000 = Freerun 001 = Lock acquisition 010 = Normal lock 011 = Holdover 100 = Lock recovery

Table 48. SYS-DPLL State Bit Field Descriptions

Bit Field Name	Field Type	Default Value	Description
FILTER_STS_SYSDPLL[47:0]	R/O	0x0	SYS-DPLL Filter status 48-bit 2's complement LSB = $2^{-53} = 1.11e-7ppb$
PHASE_STS_SYSDPLL[35:0]	R/O	0x0	SYS-DPLL phase output of TDC phase status 36-bit 2's complement LSB = $T_{SYSAPLL_VCO} / 62$ (TDC step) phase data from decimator

System DPLL (SYS-DPLL) Lock Threshold, Lock Timer, Bandwidth

Table 49. SYS-DPLL Lock Threshold, Lock Timer, Bandwidth Locations

Offset Address	D7	D6	D5	D4	D3	D2	D1	D0
0x0052	LOCK_THRESHOLD_SYSDPLL[7:0]							
0x0053	LOCK_THRESHOLD_SYSDPLL[15:8]							
0x0054	LOCK_TIMER_SYSDPLL[7:0]							
0x0055	AA_BW_SHIFT_SYSDPLL[4:0]				AA_BW_MULT_SYSDPLL[2:0]			
0x0056	NORMAL_BW_SHIFT_SYSDPLL[4:0]				NORMAL_BW_MULT_SYSDPLL[2:0]			
0x0057	Reserved		NORMAL_DAMPING_SHIFT_SYSDPLL[2:0]			NORMAL_DAMPING_MULT_SYSDPLL[2:0]		
0x0058	ACQ_BW_SHIFT_SYSDPLL[4:0]				ACQ_BW_MULT_SYSDPLL[2:0]			
0x0059	Reserved		ACQ_DAMPING_SHIFT_SYSDPLL[2:0]			ACQ_DAMPING_MULT_SYSDPLL[2:0]		
0x005A	Reserved						FILTER_STS_SELECT_SYSDPLL[1:0]	

Table 50. SYS-DPLL Lock Threshold, Lock Timer, Bandwidth Descriptions

Bit Field Name	Field Type	Default Value	Description
LOCK_THRESHOLD_SYSDPLL[15:0]	R/W	0x0115	SYS-DPLL Lock detector threshold. lock threshold 16-bit unsigned LSB = $T_{SYSAPLL_VCO} / 62$ (TDC step)
LOCK_TIMER_SYSDPLL[7:0]	R/W	0x0A	SYS-DPLL lock timer 8-bit, unsigned Lock timer = $(LOCK_TIMER_SYSDPLL[7:0] \times 2^8) / update_rate$ The range is from 2ms to 512ms in step of 2ms assuming SYS_CLK is 108MHz. If phase error is within lock_threshold for the period that the timer is set, then the dpll is declared lock

Table 50. SYS-DPLL Lock Threshold, Lock Timer, Bandwidth Descriptions

Bit Field Name	Field Type	Default Value	Description
AA_BW_SHIFT_SYSDPLL[4:0]	R/W	0x10	Anti alias shift. Anti alias shift and mult: < 33 for stability, A-A filter bandwidth=coe × f/(2π) where, coe = 2 ^{-(18-aa_bw_shift)} × aa_bw_mult/8 f = fb frequency if coe=0, A-A filter is bypassed
AA_BW_MULT_SYSDPLL[2:0]	R/W	0x4	Anti alias mult See AA_BW_SHIFT_SYSDPLL description
NORMAL_BW_SHIFT_SYSDPLL[4:0]	R/W	0x14	Normal bandwidth shift. Normal bandwidth shift and mult: < 22 for stability, BW = (K _{TDC} × K _{PEC} × K _P) / 2π Where: K _{TDC} = 1/T _{DC_STEP} (in ps) K _{PEC} = 2 ⁷ K _P = (BW_MULT / 4) × 2 ^(BW_SHIFT-53) T _{DC_STEP} = T _{SYSAPLL_VCO} / 62
NORMAL_BW_MULT_SYSDPLL[2:0]	R/W	0x4	Normal bandwidth mult See NORMAL_BW_SHIFT_SYSDPLL description
NORMAL_DAMPING_SHIFT_SYSDPLL[2:0]	R/W	0x4	Normal damping shift. Normal damping bandwidth shift and mult; The estimation for Gpeak is: Gpeak(dB) = 0.012 × 2 ^(normal_damp_shift-1) × normal_damp_mult/4 --- assuming filter update rate is 562.5kHz. if update rate double, then Gpeak double
NORMAL_DAMPING_MULT_SYSDPLL[2:0]	R/W	0x4	Normal damping mult See NORMAL_DAMPING_SHIFT_SYSDPLL description
ACQ_BW_SHIFT_SYSDPLL[4:0]	R/W	0x14	Acquire bandwidth shift. Acquire bandwidth shift and mult; < 22 for stability K _{TDC} = 1/T _{DC_STEP} (in ps) K _{PEC} = 2 ⁷ K _P = (BW_MULT / 4) × 2 ^(BW_SHIFT-53) T _{DC_STEP} = T _{SYSAPLL_VCO} / 62
ACQ_BW_MULT_SYSDPLL[2:0]	R/W	0x4	Acquire bandwidth mult. See ACQ_BW_SHIFT_SYSDPLL description
ACQ_DAMPING_SHIFT_SYSDPLL[2:0]	R/W	0x4	Acquire damping shift The estimation for Gpeak is: Gpeak(dB) = 0.012 × 2 ^(damp_shift-1) × damp_mult/4 --- assuming filter update rate is 562.5kHz. if update rate double, Gpeak double

Table 50. SYS-DPLL Lock Threshold, Lock Timer, Bandwidth Descriptions

Bit Field Name	Field Type	Default Value	Description
ACQ_DAMPING_MULT_SYSDPLL[2:0]	R/W	0x4	Acquire damping mult. See ACQ_DAMPING_SHIFT_SYSDPLL description
FILTER_STS_SELECT_SYSDPLL[1:0]	R/W	0	Selects source of the filter status register; 0 = Integrator 1 = Proportional + integrator 2 = Holdover value 3 = fcw

System DPLL (SYS-DPLL) Phase Error Compensation (PEC) and Frequency Divider

Table 51. SYS-DPLL Phase Error Compensation and Frequency Divider Bit Field Locations

Offset Address	D7	D6	D5	D4	D3	D2	D1	D0
0x005B	PEC_CORR_SYSDPLL[7:0]							
0x005C	PEC_DELAY_SYSDPLL[1:0]		PEC_CORR_SYSDPLL[13:8]					
0x005E	M_INT_SD[7:0]							
0x005F	Reserved						M_INT_SD[9:8]	
0x0060	M_NUM_SD[7:0]							
0x0061	M_NUM_SD[15:8]							
0x0062	M_DEN_SD[7:0]							
0x0063	M_DEN_SD[15:8]							

Table 52. SYS-DPLL Phase Error Compensation and Frequency Divider Bit Field Descriptions

Bit Field Name	Field Type	Default Value	Description
PEC_CORR_SYSDPLL[13:0]	R/W	0	Phase error cancellation (PEC) to compensate the phase error from the 1st-order modulated fractional feedback divider. The residual part of the fractional feedback is scaled to TDC resolution and is compensated to the TDC phase error. PEC scale factor for using CLK_0 as input: $PEC_CORR = (T_{VCO} \div T_{DC_STEP}) \times 2^{DEN_BITS/DEN}$ where: T_{VCO} : period of the feedback divider input clock T_{DC_STEP} : TDC step size DEN_BITS: total number of bits of denominator bits (16 bits for the SYS-DPLL) DEN: denominator (M_DEN_SD[15:0])
M_INT_SD[9:0]	R/W	0x56	Integer portion of the SYS-DPLL fractional feedback divider (binary coding)
M_NUM_SD[15:0]	R/W	0x2000	Numerator portion of the SYS-DPLL fractional feedback divider (binary coding)
M_DEN_SD[15:0]	R/W	0x5000	Denominator portion of the SYS-DPLL fractional feedback divider (binary coding)

Reference Monitor for Input CLK_0

Table 53. Reference Monitor CLK_0 Field Descriptions

Offset Address	D7	D6	D5	D4	D3	D2	D1	D0
0x0080	Reserved		DIV_RATIO_ST_REF_MON0[5:0]					
0x0081	NOMINAL_NUM_ST_REF_MON0[7:0]							
0x0082	ACCEPT_NUM_ST_REF_MON0[3:0]				REJECT_NUM_ST_REF_MON0[3:0]			
0x0083	GOOD_TIMES_ST_REF_MON0[3:0]				FAIL_NUM_ST_REF_MON0[3:0]			
0x0084	DIV_RATIO_MT_REF_MON0[7:0]							
0x0085	DIV_RATIO_MT_REF_MON0[15:8]							
0x0086	NOMINAL_NUM_MT_REF_MON0[7:0]							
0x0087	NOMINAL_NUM_MT_REF_MON0[15:8]							
0x0088	Reserved						NOMINAL_NUM_MT_REF_MON0[17:16]	
0x0089	ACCEPT_NUM_MT_REF_MON0[7:0]							
0x008A	ACCEPT_NUM_MT_REF_MON0[15:8]							
0x008B	REJECT_NUM_MT_REF_MON0[7:0]							
0x008C	REJECT_NUM_MT_REF_MON0[15:8]							
0x008D	GOOD_TIMES_MT_REF_MON0[3:0]				FAIL_NUM_MT_REF_MON0[3:0]			
0x008E	DIV_RATIO_LT_REF_MON0[7:0]							
0x008F	DIV_RATIO_LT_REF_MON0[15:8]							
0x0090	DIV_RATIO_LT_REF_MON0[23:16]							
0x0091	Reserved				DIV_RATIO_LT_REF_MON0[28:24]			
0x0092	NOMINAL_NUM_LT_REF_MON0[7:0]							
0x0093	NOMINAL_NUM_LT_REF_MON0[15:8]							
0x0094	NOMINAL_NUM_LT_REF_MON0[23:16]							
0x0095	NOMINAL_NUM_LT_REF_MON0[31:24]							
0x0096	ACCEPT_NUM_LT_REF_MON0[7:0]							
0x0097	ACCEPT_NUM_LT_REF_MON0[15:8]							
0x0098	Reserved		ACCEPT_NUM_LT_REF_MON0[21:16]					
0x0099	REJECT_NUM_LT_REF_MON0[7:0]							
0x009A	REJECT_NUM_LT_REF_MON0[15:8]							
0x009B	Reserved		REJECT_NUM_LT_REF_MON0[21:16]					
0x009C	GOOD_TIMES_LT_REF_MON[3:0]				FAIL_NUM_LT_REF_MON0[3:0]			
0x009D	PD_CLK0	DIS_CLK0	DIS_CLK0_B Y_PIN	Reserved			R0[2:0]	

Table 53. Reference Monitor CLK_0 Field Descriptions (Cont.)

Offset Address	D7	D6	D5	D4	D3	D2	D1	D0
0x009E	Reserved						SRC_SEL_LT_REF_MON0[1:0]	
0x009F	FREQ_NUMBER_STS_REF_MON0[7:0]							
0x00A0	FREQ_NUMBER_STS_REF_MON0[15:8]							
0x00A1	FREQ_NUMBER_STS_REF_MON0[23:16]							

Table 54. Reference Monitor CLK_0 Field Descriptions

Bit Field Name	Field Type	Default Value	Description
DIV_RATIO_ST_REF_MON0[5:0]	R/W	1	Short-term monitor divider ratio is used for monitoring the activity of input reference clock for frequencies higher than 1MHz. If DIV_RATIO_ST_REF_MON0 is set to 0 or 1, the actual short-term monitor divider ratio is 1. Otherwise short-term monitor divider ratio = DIV_RATIO_ST_REF_MON0 +2
NOMINAL_NUM_ST_REF_MON0[7:0]	R/W	0x6E	Nominal number of SYS_CLK cycles within the counter window, which is: $f_{SYS_CLK}/(f_{REF}/div_ratio)$.
ACCEPT_NUM_ST_REF_MON0[3:0]	R/W	0xB	Accept number, if counter value is within nominal_num ± accept_num, then the good counter increases by 1, and the fail counter is cleared.
REJECT_NUM_ST_REF_MON0[3:0]	R/W	0xF	Reject number, if counter value outside nominal_num ± reject_num, then fail counter increases by 1, and the good timer is cleared.
GOOD_TIMES_ST_REF_MON0[3:0]	R/W	0x4	Number of times cycle is within window before it is reported as good. If good counter reaches the number programmed in these bits, then the reference is declared good. To declare a reference to be qualified, it must be detected good continuously for the number of good times
FAIL_NUM_ST_REF_MON0[3:0]	R/W	0x1	If failure time reaches the number programmed in these bits, then the reference is declared fail, set alarm and interrupt.
DIV_RATIO_MT_REF_MON0[15:0]	R/W	0x4B00	Medium-term monitor divider ratio is used for medium-term monitoring If DIV_RATIO_NT_REF_MON0 is set to 0 or 1, the actual medium-term monitor divider ratio is 1. Otherwise medium-term monitor divider ratio = DIV_RATIO_MT_REF_MON0 +2
NOMINAL_NUM_MT_REF_MON0[17:0]	R/W	0x20F58	Nominal number of SYS_CLK cycles within the counter window, which is: $f_{SYS_CLK}/(f_{REF}/div_ratio)$
ACCEPT_NUM_MT_REF_MON0[15:0]	R/W	0x83D6	Accept number, if counter value is within nominal_num ± accept_num, then the good counter increases by 1, and the fail counter is cleared
REJECT_NUM_MT_REF_MON0[15:0]	R/W	0xB892	Reject number, if counter value outside nominal_num ± reject_num, then the fail counter increases by 1, and the good timer is cleared.
GOOD_TIMES_MT_REF_MON0[3:0]	R/W	0100	Number of times cycle is within window before it is reported as good. If good counter reaches the number programmed in these bits, then the reference is declared good. To declare a reference to be qualified, it must be detected good continuously for the number of good times.
FAIL_NUM_MT_REF_MON0[3:0]	R/W	0001	If medium-term monitor failure time reaches the number programmed in these bits, then the reference is declared fail, set alarm and interrupt.

Table 54. Reference Monitor CLK_0 Field Descriptions (Cont.)

Bit Field Name	Field Type	Default Value	Description
DIV_RATIO_LT_REF_MON0[28:0]	R/W	0x0927C000	Long-term monitor divider ratio is used for long-term monitoring If DIV_RATIO_LT_REF_MON0 is set to 0 or 1, the actual long-term monitor divider ratio is 1. Otherwise long-term monitor divider ratio = DIV_RATIO_MT_REF_MON0 +2
NOMINAL_NUM_LT_REF_MON0[31:0]	R/W	0x405F7E00	Nominal number of SYS_CLK cycles within the counter window, which is: $f_{SYS_CLK}/(f_{REF}/div_ratio)$
ACCEPT_NUM_LT_REF_MON0[21:0]	R/W	0x0032A0	Accept number, if counter value is within nominal_num ± accept_num, then the good counter increases by 1, and the fail counter is cleared.
REJECT_NUM_LT_REF_MON0[21:0]	R/W	0x003B10	Reject number, if counter value is outside nominal_num ± reject_num, fail = 1, then the fail counter increases by 1, and the good timer is cleared.
GOOD_TIMES_LT_REF_MON0[3:0]	R/W	0100	Number of times cycle is within window before it is reported as good. If good counter reaches the number programmed in these bits, then the reference is declared good. To declare a reference to be qualified, it must be detected good continuously for the number of good times.
FAIL_NUM_LT_REF_MON0[3:0]	R/W	0001	If long-term monitor failure time reaches the number programmed in these bits, then the reference is declared fail, set alarm and interrupt.
PD_CLK0	R/W	1	Power down ref clock path. 0 = CLK_0 path is powered on 1 = CLK_0 path is powered off
DIS_CLK0	R/W	0	This bit disables input CLK_0 reference from being selected for DPLL-0 and DPLL-1 to lock to it. 0 = CLK_0 reference can be selected 1 = CLK_0 reference can not be selected
DIS_CLK0_BY_PIN	R/W	0	If this bit is set, then GPIO can be used to enable or disable input CLK_0 reference to be selected for DPLL-0 and DPLL-1 to lock to it. 0 = CLK_0 reference can be disabled by bit DIS_CLK0 1 = CLK_0 reference can be disabled by GPIO
R0[2:0]	R/W	000	Input CLK_0 reference clock high frequency pre-divider. The reference frequency must be divided down to a maximum of $SYS_CLK \div 3$ (< 36MHz) by the high frequency pre-divider. 000 = ÷1 001 = ÷2 010 = ÷4 011 = ÷8 100 = ÷16 101 = ÷32

Table 54. Reference Monitor CLK_0 Field Descriptions (Cont.)

Bit Field Name	Field Type	Default Value	Description
SRC_SEL_LT_REF_MON0[1:0]	R/W	00	Long term reference monitor clock source selection for CLK_0 00 = SYS_CLK 01 = OSCI/OSCO (crystal oscillator) 1x = XO_DPLL
FREQ_NUMBER_STS_REF_MON0[23:0]	R/O	0	Status of the frequency monitor counter (2's complement) This register is 24-bit signed, it represents the reference clock fractional frequency offset with respect to the SYS_CLK or optionally OSCI/OSCO/XO_DPLL. The frequency offset in ppm is: $10^6 \times 2^{-32} \times \text{FREQ_NUMBER_STS_REF_MON0}[23:0]$ The LSB is $2^{-32} \times 10^6$ ppm.

Reference Monitor for Input CLK_1

Table 55. Reference Monitor CLK_1 Field Locations

Offset Address	D7	D6	D5	D4	D3	D2	D1	D0
0x00B0	Reserved		DIV_RATIO_ST_REF_MON1[5:0]					
0x00B1	NOMINAL_NUM_ST_REF_MON1[7:0]							
0x00B2	ACCEPT_NUM_ST_REF_MON1[3:0]				REJECT_NUM_ST_REF_MON1[3:0]			
0x00B3	GOOD_TIMES_ST_REF_MON1[3:0]				FAIL_NUM_ST_REF_MON1[3:0]			
0x00B4	DIV_RATIO_MT_REF_MON1[7:0]							
0x00B5	DIV_RATIO_MT_REF_MON1[15:8]							
0x00B6	NOMINAL_NUM_MT_REF_MON1[7:0]							
0x00B7	NOMINAL_NUM_MT_REF_MON1[15:8]							
0x00B8	Reserved						NOMINAL_NUM_MT_REF_MON1[17:16]	
0x00B9	ACCEPT_NUM_MT_REF_MON1[7:0]							
0x00BA	ACCEPT_NUM_MT_REF_MON1[15:8]							
0x00BB	REJECT_NUM_MT_REF_MON1[7:0]							
0x00BC	REJECT_NUM_MT_REF_MON1[15:8]							
0x00BD	GOOD_TIMES_MT_REF_MON1[3:0]				FAIL_NUM_MT_REF_MON1[3:0]			
0x00BE	DIV_RATIO_LT_REF_MON1[7:0]							
0x00BF	DIV_RATIO_LT_REF_MON1[15:8]							
0x00C0	DIV_RATIO_LT_REF_MON1[23:16]							
0x00C1	Reserved			DIV_RATIO_LT_REF_MON1[28:24]				
0x00C2	NOMINAL_NUM_LT_REF_MON1[7:0]							
0x00C3	NOMINAL_NUM_LT_REF_MON1[15:8]							
0x00C4	NOMINAL_NUM_LT_REF_MON1[23:16]							
0x00C5	NOMINAL_NUM_LT_REF_MON1[31:24]							
0x00C6	ACCEPT_NUM_LT_REF_MON1[7:0]							
0x00C7	ACCEPT_NUM_LT_REF_MON1[15:8]							
0x00C8	Reserved		ACCEPT_NUM_LT_REF_MON1[21:16]					
0x00C9	REJECT_NUM_LT_REF_MON1[7:0]							
0x00CA	REJECT_NUM_LT_REF_MON1[15:8]							
0x00CB	Reserved		REJECT_NUM_LT_REF_MON1[21:16]					
0x00CC	GOOD_TIMES_LT_REF_MON1[3:0]				FAIL_NUM_LT_REF_MON1[3:0]			
0x00CD	PD_CLK1	DIS_CLK1	DIS_CLK1_B Y_PIN	Reserved			R1[2:0]	

Table 55. Reference Monitor CLK_1 Field Locations (Cont.)

Offset Address	D7	D6	D5	D4	D3	D2	D1	D0
0x00CE	Reserved						SRC_SEL_LT_REF_MON1[1:0]	
0x00CF	FREQ_NUMBER_STS_REF_MON1[7:0]							
0x00D0	FREQ_NUMBER_STS_REF_MON1[15:8]							
0x00D1	FREQ_NUMBER_STS_REF_MON1[23:16]							

Table 56. Reference Monitor CLK_1 Field Descriptions

Bit Field Name	Field Type	Default Value	Description
DIV_RATIO_ST_REF_MON1[5:0]	R/W	6	Short-term monitor divider ratio is used for monitoring the activity of input reference clock for frequencies higher than 1MHz. If DIV_RATIO_ST_REF_MON1 is set to 0 or 1, the actual short-term monitor divider ratio is 1. Otherwise short-term monitor divider ratio = DIV_RATIO_ST_REF_MON1 +2
NOMINAL_NUM_ST_REF_MON1[7:0]	R/W	0x2E	Nominal number of SYS_CLK cycles within the counter window, which is: $f_{SYS_CLK}/(f_{REF}/div_ratio)$
ACCEPT_NUM_ST_REF_MON1[3:0]	R/W	1000	Accept number, if counter value is within nominal_num ± accept_num, then the good counter increases by 1, and the fail counter is cleared.
REJECT_NUM_ST_REF_MON1[3:0]	R/W	1111	Reject number, if counter value outside nominal_num ± reject_num, then fail counter increases by 1, and the good timer is cleared.
GOOD_TIMES_ST_REF_MON1[3:0]	R/W	0100	Number of times cycle is within window before it is reported as good. If good counter reaches the number programmed in these bits, then the reference is declared good. To declare a reference to be qualified, it must be detected good continuously for the number of good times.
FAIL_NUM_ST_REF_MON1[3:0]	R/W	0001	If failure time reaches the number programmed in these bits, then the reference is declared fail, set alarm and interrupt.
DIV_RATIO_MT_REF_MON1[15:0]	R/W	0x4B00	Medium-term monitor divider ratio is used for medium-term monitoring If DIV_RATIO_NT_REF_MON1 is set to 0 or 1, the actual medium-term monitor divider ratio is 1. Otherwise medium-term monitor divider ratio = DIV_RATIO_MT_REF_MON1 +2
NOMINAL_NUM_MT_REF_MON1[17:0]	R/W	0x20F58	Nominal number of SYS_CLK cycles within the counter window, which is: $f_{SYS_CLK}/(f_{REF}/div_ratio)$.
ACCEPT_NUM_MT_REF_MON1[15:0]	R/W	0x83D6	Accept number, if counter value is within nominal_num ± accept_num, then the good counter increases by 1, and the fail counter is cleared.
REJECT_NUM_MT_REF_MON1[15:0]	R/W	0xB892	Reject number, if counter value outside nominal_num ± reject_num, then the fail counter increases by 1, and the good timer is cleared.
GOOD_TIMES_MT_REF_MON1[3:0]	R/W	0100	Number of times cycle is within window before it is reported as good. If good counter reaches the number programmed in these bits, then the reference is declared good. To declare a reference to be qualified, it must be detected good continuously for the number of good times.
FAIL_NUM_MT_REF_MON1[3:0]	R/W	0001	If medium-term monitor failure time reaches the number programmed in these bits, then the reference is declared fail, set alarm and interrupt.

Table 56. Reference Monitor CLK_1 Field Descriptions (Cont.)

Bit Field Name	Field Type	Default Value	Description
DIV_RATIO_LT_REF_MON1[28:0]	R/W	0x0927C000	Long-term monitor divider ratio is used for long-term monitoring If DIV_RATIO_LT_REF_MON1 is set to 0 or 1, the actual long-term monitor divider ratio is 1. Otherwise long-term monitor divider ratio = DIV_RATIO_MT_REF_MON1 +2
NOMINAL_NUM_LT_REF_MON1[31:0]	R/W	405F7E00h	Nominal number of SYS_CLK cycles within the counter window, which is: $f_{SYS_CLK}/(f_{REF}/div_ratio)$.
ACCEPT_NUM_LT_REF_MON1[21:0]	R/W	0x0032A0	Accept number, if counter value is within nominal_num ± accept_num, then the good counter increases by 1, and the fail counter is cleared.
REJECT_NUM_LT_REF_MON1[21:0]	R/W	0x003B10	Reject number, if counter value is outside nominal_num ± reject_num, fail = 1, then the fail counter increases by 1, and the good timer is cleared.
GOOD_TIMES_LT_REF_MON1[3:0]	R/W	0100	Number of times cycle is within window before it is reported as good. If good counter reaches the number programmed in these bits, then the reference is declared good. To declare a reference to be qualified, it must be detected good continuously for the number of good times.
FAIL_NUM_LT_REF_MON1[3:0]	R/W	0001	If long-term monitor failure time reaches the number programmed in these bits, then the reference is declared fail, set alarm and interrupt.
PD_CLK1	R/W	1	Power down ref clock path. 0 = CLK_1 path is powered on 1 = CLK_1 path is powered off
DIS_CLK1	R/W	0	This bit disables input CLK_1 reference from being selected for DPLL-0 and DPLL-1 to lock to it. 0 = CLK_1 reference can be selected 1 = CLK_1 reference can not be selected
DIS_CLK1_BY_PIN	R/W	0	If this bit is set, then GPIO can be used to enable or disable input CLK_1 reference to be selected for DPLL-0 and DPLL-1 to lock to it. 0 = CLK_1 reference can be disabled by bit DIS_CLK1 1 = CLK_1 reference can be disabled by GPIO
R1[2:0]	R/W	000	Input CLK_1 reference clock high frequency pre-divider. The reference frequency must be divided down to a maximum of $SYS_CLK \div 3$ (< 36MHz) by the high frequency pre-divider. 000 = ÷1 001 = ÷2 010 = ÷4 011 = ÷8 100 = ÷16 101 = ÷32

Table 56. Reference Monitor CLK_1 Field Descriptions (Cont.)

Bit Field Name	Field Type	Default Value	Description
SRC_SEL_LT_REF_MON1[1:0]	R/W	00	Long term reference monitor clock source selection for CLK_1 00 = SYS_CLK 01 = OSCI/OSCO (crystal oscillator) 1x = XO_DPLL
FREQ_NUMBER_STS_REF_MON1[23:0]	R/O	0	Status of the frequency monitor counter (2's complement) This register is 24-bit signed, it represents the reference clock fractional frequency offset with respect to the SYS_CLK. The frequency offset in ppm is: $10^6 \times 2^{-32} \times \text{FREQ_NUMBER_STS_REF_MON1}[23:0]$ The LSB is $2^{-32} \times 10^6$ ppm.

Global Status

Table 57. Globals Status Bit Field Locations

Offset Address	D7	D6	D5	D4	D3	D2	D1	D0
0x00E0	Reserved	CLK1_FAIL_ST_DISQUAL_MASK	CLK1_FAIL_MT_DISQUAL_MASK	CLK1_FAIL_LT_DISQUAL_MASK	Reserved	CLK0_FAIL_ST_DISQUAL_MASK	CLK0_FAIL_MT_DISQUAL_MASK	CLK0_FAIL_LT_DISQUAL_MASK
0x00E1	CLK1_INVALID	CLK1_FAIL_ST	CLK1_FAIL_MT	CLK1_FAIL_LT	CLK0_INVALID	CLK0_FAIL_ST	CLK0_FAIL_MT	CLK0_FAIL_LT
0x00E2	Reserved	CLK1_FAIL_ST_INT	CLK1_FAIL_MT_INT	CLK1_FAIL_LT_INT	Reserved	CLK0_FAIL_ST_INT	CLK0_FAIL_MT_INT	CLK0_FAIL_LT_INT
0x00E3	Reserved	DPLL1_STATE_CHANGE_INT	DPLL1_HOLD_OVER_INT	DPLL1_LOSS_OF_LOCK_INT	Reserved	DPLL0_STATE_CHANGE_INT	DPLL0_HOLD_OVER_INT	DPLL0_LOSS_OF_LOCK_INT
0x00E4	Reserved	SYSDPLL_STATE_CHANGE_INT	SYSDPLL_HOLD_OVER_INT	SYSDPLL_LOSS_OF_LOCK_INT	RFPLL_LOSS_OF_LOCK_INT	APLL2_LOSS_OF_LOCK_INT	APLL1_LOSS_OF_LOCK_INT	APLL0_LOSS_OF_LOCK_INT
0x00E5	Reserved	CLK1_FAIL_ST_MASK	CLK1_FAIL_MT_MASK	CLK1_FAIL_LT_MASK	Reserved	CLK0_FAIL_ST_MASK	CLK0_FAIL_MT_MASK	CLK0_FAIL_LT_MASK
0x00E6	Reserved	DPLL1_STATE_CHANGE_MASK	DPLL1_HOLD_OVER_MASK	DPLL1_LOSS_OF_LOCK_MASK	Reserved	DPLL0_STATE_CHANGE_MASK	DPLL0_HOLD_OVER_MASK	DPLL0_LOSS_OF_LOCK_MASK
0x00E7	Reserved	SYSDPLL_STATE_CHANGE_MASK	SYSDPLL_HOLD_OVER_MASK	SYSDPLL_LOSS_OF_LOCK_MASK	RFPLL_LOSS_OF_LOCK_MASK	APLL2_LOSS_OF_LOCK_MASK	APLL1_LOSS_OF_LOCK_MASK	APLL0_LOSS_OF_LOCK_MASK

Table 58. Globals Status Bit Field Descriptions

Bit Field Name	Field Type	Default Value	Description
CLK1_FAIL_ST_DISQUAL_MASK	R/W	0	If this bit is asserted, then short-term monitor failure does not disqualify CLK_1 0 = Not masked 1 = Masked
CLK1_FAIL_MT_DISQUAL_MASK	R/W	0	If this bit is asserted, then medium-term monitor failure does not disqualify CLK_1 0 = Not masked 1 = Masked
CLK1_FAIL_LT_DISQUAL_MASK	R/W	0	If this bit is asserted, then long-term monitor failure does not disqualify CLK_1 0 = Not masked 1 = Masked
CLK0_FAIL_ST_DISQUAL_MASK	R/W	0	If this bit is asserted, then short-term monitor failure does not disqualify CLK_0 0 = Not masked 1 = Masked
CLK0_FAIL_MT_DISQUAL_MASK	R/W	0	If this bit is asserted, then medium-term monitor failure does not disqualify CLK_0 0 = Not masked 1 = Masked

Table 58. Globals Status Bit Field Descriptions (Cont.)

Bit Field Name	Field Type	Default Value	Description
CLK0_FAIL_LT_DISQUAL_MASK	R/W	0	If this bit is asserted, then long-term monitor failure does not disqualify CLK_0 0 = Not masked 1 = Masked
CLK1_INVALID	R/O	0	Status of the CLK_1 input 0 = Valid 1 = Invalid
CLK1_FAIL_ST	R/O	0	Status of the short-term reference monitor of the CLK_1 input 0 = Good 1 = Failed
CLK1_FAIL_MT	R/O	0	Status of the medium-term reference monitor of the CLK_1 input 0 = Good 1 = Failed
CLK1_FAIL_LT	R/O	0	Status of the long-term reference monitor of the CLK_1 input 0 = Good 1 = Failed
CLK0_INVALID	R/O	0	Status of the CLK_0 input 0 = Valid 1 = Invalid
CLK0_FAIL_ST	R/O	0	Momentary status of the short-term reference monitor of the CLK_0 input 0 = Good 1 = Failed
CLK0_FAIL_MT	R/O	0	Momentary status of the medium-term reference monitor of the CLK_0 input 0 = Good 1 = Failed
CLK0_FAIL_LT	R/O	0	Momentary status of the long-term reference monitor of the CLK_0 input 0 = Good 1 = Failed
CLK1_FAIL_ST_INT	RW1C	0	Latched status of the short-term reference monitor of the CLK_1 input 0 = Good 1 = Failed Write 1 to clear the latched status bit.
CLK1_FAIL_MT_INT	RW1C	0	Latched status of the mid-term reference monitor of the CLK_1 input 0 = Good 1 = Failed Write 1 to clear the latched status bit.
CLK1_FAIL_LT_INT	RW1C	0	Latched status of the long-term reference monitor of the CLK_1 input 0 = Good 1 = Failed Write 1 to clear the latched status bit.
CLK0_FAIL_ST_INT	RW1C	0	Latched status of the short-term reference monitor of the CLK_0 input 0 = Good 1 = Failed Write 1 to clear the latched status bit.

Table 58. Globals Status Bit Field Descriptions (Cont.)

Bit Field Name	Field Type	Default Value	Description
CLK0_FAIL_MT_INT	RW1C	0	Latched status of the mid-term reference monitor of the CLK_0 input 0 = Good 1 = Failed Write 1 to clear the latched status bit.
CLK0_FAIL_LT_INT	RW1C	0	Latched status of the long-term reference monitor of the CLK_0 input 0 = Good 1 = Failed Write 1 to clear the latched status bit.
DPLL1_STATE_CHANGE_INT	RW1C	0	DPLL-1 state changed latched interrupt, indicates DPLL state changed
DPLL1_HOLD OVER_INT	RW1C	0	DPLL-1 holdover latched interrupt, indicates holdover state changed, i.e. enter or exit holdover
DPLL1_LOSS_OF_LOCK_INT	RW1C	0	DPLL-1 loss of lock latched interrupt, indicates loss of lock detected.
Reserved	RW1C	0	Reserved. Do not modify this value.
DPLL0_STATE_CHANGE_INT	RW1C	0	DPLL-0 state changed latched interrupt, indicates DPLL-0 state changed.
DPLL0_HOLD OVER_INT	RW1C	0	DPLL-0 holdover latched interrupt, indicates holdover state changed, i.e. enter or exit holdover.
DPLL0_LOSS_OF_LOCK_INT	RW1C	0	DPLL-0 loss of lock latched interrupt, indicates loss of lock detected.
SYSDPLL_STATE_CHANGE_INT	RW1C	0	SYS-DPLL state changed latched interrupt, indicates SYS-DPLL state changed
SYSDPLL_HOLD OVER_INT	RW1C	0	SYS-DPLL holdover latched interrupt, indicates holdover state changed, i.e. enter or exit holdover.
SYSDPLL_LOSS_OF_LOCK_INT	RW1C	0	SYS-DPLL loss of lock latched interrupt, indicates loss of lock detected.
RFPLL_LOSS_OF_LOCK_INT	RW1C	0	RF-PLL loss of lock latched interrupt, indicates loss of lock detected.
APLL2_LOSS_OF_LOCK_INT	RW1C	0	APLL-2 loss of lock latched interrupt, indicates loss of lock detected.
APLL1_LOSS_OF_LOCK_INT	RW1C	0	APLL-1 loss of lock latched interrupt, indicates loss of lock detected.
APLL0_LOSS_OF_LOCK_INT	RW1C	0	APLL-0 loss of lock latched interrupt, indicates loss of lock detected.
CLK1_FAIL_ST_MASK	R/W	0	Interrupt mask for the CLK_1 input short-term monitor If this bit is asserted, a failure of the CLK_1 input short-term monitor does not generate an interrupt, and the short-term failure does not disqualify the CLK_1 reference. 0 = Short-term monitor interrupt is not masked 1 = Short-term monitor interrupt is masked (no interrupt generated)

Table 58. Globals Status Bit Field Descriptions (Cont.)

Bit Field Name	Field Type	Default Value	Description
CLK1_FAIL_MT_MASK	R/W	0	Interrupt mask for the CLK_1 input medium-term monitor If this bit is asserted, a failure of the CLK_1 input medium-term monitor does not generate an interrupt, and the medium-term failure does not disqualify the CLK_1 reference. 0 = Medium-term monitor interrupt is not masked 1 = Medium-term monitor interrupt is masked (no interrupt generated)
CLK1_FAIL_LT_MASK	R/W	0	Interrupt mask for the CLK_1 input long-term monitor If this bit is asserted, a failure of the CLK_1 input long-term monitor does not generate an interrupt, and the long-term failure does not disqualify the CLK_1 reference. 0 = Long-term monitor interrupt is not masked 1 = Long-term monitor interrupt is masked (no interrupt generated)
CLK0_FAIL_ST_MASK	R/W	0	Interrupt mask for the CLK_0 input short-term monitor If this bit is asserted, a failure of the CLK_0 input short-term monitor does not generate an interrupt, and the short-term failure does not disqualify the CLK_0 reference. 0 = Short-term monitor interrupt is not masked 1 = Short-term monitor interrupt is masked (no interrupt generated)
CLK0_FAIL_MT_MASK	R/W	0	Interrupt mask for the CLK_0 input medium-term monitor If this bit is asserted, a failure of the CLK_0 input medium-term monitor does not generate an interrupt, and the medium-term failure does not disqualify the CLK_0 reference. 0 = Medium-term monitor interrupt is not masked 1 = Medium-term monitor interrupt is masked (no interrupt generated)
CLK0_FAIL_LT_MASK	R/W	0	Interrupt mask for the CLK_0 input long-term monitor If this bit is asserted, a failure of the CLK_0 input long-term monitor does not generate an interrupt, and the long-term failure does not disqualify the CLK_0 reference. 0 = Long-term monitor interrupt is not masked 1 = Long-term monitor interrupt is masked (no interrupt generated)
DPLL1_STATE_CHANGE_MASK	R/W	0	Mask for DPLL-1 state change interrupt. If this bit is asserted, then an interrupt is not generated when DPLL-1 state is changed. 0 = Not masked 1 = Masked
DPLL1_HOLDOVER_MASK	R/W	0	Mask for DPLL-1 holdover interrupt. If this bit is asserted, then an interrupt is not generated when DPLL-1 enters or exits holdover. 0 = Not masked 1 = Masked
DPLL1_LOSS_OF_LOCK_MASK	R/W	0	Mask for DPLL-1 loss of lock interrupt. If this bit is asserted, then an interrupt is not generated when DPLL-1 loses lock. 0 = Not masked 1 = Masked
Reserved	R/W	0	Reserved. Do not modify this value.

Table 58. Globals Status Bit Field Descriptions (Cont.)

Bit Field Name	Field Type	Default Value	Description
DPLL0_STATE_CHANGE_MASK	R/W	0	Mask for DPLL-0 state change interrupt. If this bit is asserted, then an interrupt is not generated when DPLL-0 state is changed. 0 = Not masked 1 = Masked
DPLL0_HOLDOVER_MASK	R/W	0	Mask for DPLL-0 holdover interrupt. If this bit is asserted, then an interrupt is not generated when DPLL-0 enters or exits holdover. 0 = Not masked 1 = masked
DPLL0_LOSS_OF_LOCK_MASK	R/W	0	Mask for DPLL-0 loss of lock interrupt. If this bit is asserted, then an interrupt is not generated when DPLL-0 loses lock. 0 = Not masked 1 = Masked
SYSDPLL_STATE_CHANGE_MASK	R/W	0	Mask for SYS-DPLL state change interrupt. If this bit is asserted, then an interrupt is not generated when SYS-DPLL state is changed. 0 = Not masked 1 = Masked
SYSDPLL_HOLDOVER_MASK	R/W	0	Mask for SYS-DPLL holdover interrupt. If this bit is asserted, then an interrupt is not generated when SYS-DPLL enters or exits holdover. 0 = Not masked 1 = Masked
SYSDPLL_LOSS_OF_LOCK_MASK	R/W	0	Mask for SYS-DPLL loss of lock interrupt. If this bit is asserted, then an interrupt is not generated when SYS-DPLL loses lock. 0 = Not masked 1 = Masked
RFPLL_LOSS_OF_LOCK_MASK	R/W	0	Mask for RF-PLL loss of lock latched interrupt. If this bit is asserted, then an interrupt is not generated when RF-DPLL loses lock. 0 = Not masked 1 = Masked
APLL2_LOSS_OF_LOCK_MASK	R/W	0	Mask for APLL-2 loss of lock latched interrupt. If this bit is asserted, then an interrupt is not generated when APLL-2 loses lock. 0 = Not masked 1 = Masked
APLL1_LOSS_OF_LOCK_MASK	R/W	0	Mask for APLL-1 loss of lock latched interrupt If this bit is asserted, then an interrupt is not generated when APLL-1 loses lock. 0 = Not masked 1 = Masked
APLL0_LOSS_OF_LOCK_MASK	R/W	0	Mask for APLL-0 loss of lock latched interrupt If this bit is asserted, then an interrupt is not generated when APLL-0 loses lock. 0 = Not masked 1 = Masked

DPLL-0 (APLL-0) Frequency Configuration

Table 59. DPLL-0 (APLL-0) Frequency Configuration Field Locations

Address	D7	D6	D5	D4	D3	D2	D1	D0
0x0100	M_INT_APLL0[7:0]							
0x0101	Reserved						M_INT_APLL0[9:8]	
0x0102	M0_INT_DPLL0[7:0]							
0x0103	M0_INT_DPLL0[15:8]							
0x0104	M0_INT_DPLL0[23:16]							
0x0105	M0_INT_DPLL0[31:24]							
0x0106	1	1	Reserved					
0x0107	PD_APLL0	PD_PFD_APLL0	PD_FB_APLL0	PD_FB_DPLL0	PD_P0	Reserved		
0x0108	M_NUM_APLL0[7:0]							
0x0109	M_NUM_APLL0[15:8]							
0x010A	M_NUM_APLL0[23:16]							
0x010C	M_DEN_APLL0[7:0]							
0x010D	M_DEN_APLL0[15:8]							
0x010E	M_DEN_APLL0[23:16]							
0x0110	CAL_REF_APLL0[7:0]							
0x0111	CAL_EN_APLL0	Reserved	CAL_REF_APLL0[13:8]					
0x0112	Reserved	P0[6:0]						

Table 60. DPLL-0 (APLL-0) Frequency Configuration Field Descriptions

Bit Field Name	Field Type	Default Value	Description
M_INT_APLL0[9:0]	R/W	0x1A	Integer portion of the fractional feedback divider of APLL-0 (binary coding).
M0_INT_DPLL0[31:0]	R/W	0xA00	Integer portion of the fractional feedback divider of DPLL-0 for input clock 0 (CLK_0), (binary coding).
PD_APLL0	R/W	0	Power down APLL-0 (except VCO of APLL-0) 0 = Power up 1 = Power down
PD_PFD_APLL0	R/W	0	Power down APLL-0 phase frequency detector 0 = Power up 1 = Power down
PD_FB_APLL0	R/W	0	Power down APLL-0 feedback divider M 0 = Power up 1 = Power down

Table 60. DPLL-0 (APLL-0) Frequency Configuration Field Descriptions (Cont.)

Bit Field Name	Field Type	Default Value	Description
PD_FB_DPLL0	R/W	1	Power down DPLL-0 feedback divider M0, M1 0 = Power up 1 = Power down
PD_P0	R/W	1	Power down P0 (post-divider of APLL-0) 0 = Power up 1 = Power down
M_NUM_APLL0[23:0]	R/W	0x040000	Numerator portion of the fractional feedback divider of APLL-0 (binary coding)
M_DEN_APLL0[23:0]	R/W	0x600000	Denominator portion of the fractional feedback divider of APLL-0 (binary coding)
CAL_REF_APLL0[13:0]	R/W	0x624	APLL-0 Calibration reference frequency divider $CAL_REF_APLL0[13:0] = 16384 \times f_{APLL0_REF} / (2 \times f_{VCO} \times 10\%)$ f_{APLL0_REF} is the reference frequency of APLL-0 (OSCI/ or XO_DPLL).
CAL_EN_APLL0	R/W	1	APLL-0 calibration (VCO band selection) enable 0 = Calibration is disabled 1 = Calibration is enabled
P0[6:0]	R/W	0x10	APLL-0 Post Divider (binary coding) Divides the output frequency of APLL-0 to a lower value. Use this divider, together with the two other ± 2 dividers in the signal path from the VCO (APLL-0), to lower the value of the VCO frequency (2450-2580MHz) routed to the RF-PLL or to APLL-2 to a frequency less than 250MHz (less than 160MHz if APLL-2 is in fractional mode and its source is APLL-0).

DPLL-0 (APLL-0) DSM Control and APLL-0 Charge Pump Configuration

Table 61. DPLL-0 (APLL-0) DSM Control and APLL-0 Charge Pump Locations and Descriptions

Address	D7	D6	D5	D4	D3	D2	D1	D0
0x0114	Reserved	DSM_DITH_EN_APLL0	DSM_DITH_NS_APLL0	DSM_DITH_GAIN_APLL0[1:0]		DSM_ORDER_APLL0[1:0]		Reserved
0x0115	EN_CP_APLL0	Reserved	ICP_OFFSET_APLL0[5:0]					
0x0116	GBOOST_APLL0[3:0]			EN_CPC_APLL0[3:0]				
0x0117	SOURCE_APLL0[3:0]			SINK_APLL0[3:0]				

Table 62. DPLL-0 (APLL-0) DSM Control and Charge Pump Locations and Descriptions

Bit Field Name	Field Type	Default Value	Description
DSM_DITH_EN_APLL0	R/W	0	Dither enable for DSM of APLL-0. Value will be determined by Renesas. 0 = Dither off 1 = Dither on
DSM_DITH_NS_APLL0	R/W	0	Noise shaping for APLL-0 DSM. Value will be determined by Renesas. 0 = Dither not shaped 1 = Dither shaped
DSM_DITH_GAIN_APLL0[1:0]	R/W	0	Gain control for APLL-0 DSM. Value will be determined by Renesas. 00 = LSB 01 = 2×LSB 10 = 4×LSB 11 = 8×LSB
DSM_ORDER_APLL0[1:0]	R/W	3	Order for the APLL-0 DSM. Will be determined by Renesas. 00 = No accum 01 = First order 10 = Second order 11 = Third order
EN_CP_APLL0	R/W	1	APLL-0 enable charge pump 0 = Disable charge pump current 1 = Enable charge pump current
ICP_OFFSET_APLL0[5:0]	R/W	0x20	APLL-0 programmable charge pump offset output current. ICP_OFFSET_APLL0 is an additive current applied to ICP_APLL0_PLL effectively introducing a phase offset into the APLL-0. Use ICP_OFFSET_APLL0 to improve charge pump linearity and APLL-0 phase noise. Offset current is programmable between 12.5µA and 487.5µA in 12.5µA steps. $ICP = ICP_OFFSET_APLL0[0] \times 12.5\mu A + ICP_OFFSET_APLL0[1] \times 25\mu A + ICP_OFFSET_APLL0[2] \times 50.0\mu A + ICP_OFFSET_APLL0[3] \times 100\mu A + ICP_OFFSET_APLL0[4] \times 100\mu A + ICP_OFFSET_APLL0[5] \times 200\mu A$
GBOOST_APLL0[3:0]	R/W	1111	APLL-0 Programmable reference voltage setting the voltage drops across the gain boosted cascode circuits.

Table 62. DPLL-0 (APLL-0) DSM Control and Charge Pump Locations and Descriptions (Cont.)

Bit Field Name	Field Type	Default Value	Description
EN_CPC_APLL0[3:0]	R/W	1111	<p>The charge pump of APLL-0 contains of the parallel connection of identical 4 cores. When set to 1, each bit enables one charge pump core. Enabled charge pump cores are additive.</p> <p>0000 = no charge pump core enabled</p> <p>...</p> <p>1111 = 4 charge pump cores are enabled</p> <p>The APLL-0 charge pump current is programmable between 0μA and 2mA (source current) and in between 0μA to 500μA (sink current).</p> <p>APLL-0 source current (ICP_APLL-0):</p> $= 500\mu\text{A} \times (\text{EN_CPC_APLL0}[0] \times \text{SOURCE_APLL0}[0] + \text{EN_CPC_APLL0}[1] \times \text{SOURCE_APLL0}[1] + \text{EN_CPC_APLL0}[2] \times \text{SOURCE_APLL0}[2] + \text{EN_CPC_APLL0}[3] \times \text{SOURCE_APLL0}[3])$ <p>APLL-0 sink current (ICP_APLL-0):</p> $= 250\mu\text{A} \times (\text{EN_CPC_APLL0}[0] \times \text{SINK_APLL0}[0] + \text{EN_CPC_APLL0}[1] \times \text{SINK_APLL0}[1] + \text{EN_CPC_APLL0}[2] \times \text{SINK_APLL0}[2] + \text{EN_CPC_APLL0}[3] \times \text{SINK_APLL0}[3])$
SOURCE_APLL0[3:0]	R/W	1111	<p>APLL-0 individual charge pump source current enable.</p> <p>Each bit is defined as:</p> <p>0 = Charge pump n (n=0 to 3) source current disabled</p> <p>1 = Charge pump n (n=0 to 3) source current enabled</p>
SINK_APLL0[3:0]	R/W	0000	<p>APLL-0 individual charge pump sink current enable.</p> <p>Each bit is defined as:</p> <p>0 = Charge pump n (n=0 to 3) sink current disabled</p> <p>1 = Charge pump n (n=0 to 3) sink current enabled</p>

DPLL-0 Feedback Divider M0

Table 63. DPLL-0 Feedback Divider M0 Register Locations

Address	D7	D6	D5	D4	D3	D2	D1	D0
0x0118	M0_NUM_DPLL0[7:0]							
0x0119	M0_NUM_DPLL0[15:8]							
0x011A	M0_NUM_DPLL0[23:16]							
0x011C	M0_DEN_DPLL0[7:0]							
0x011D	M0_DEN_DPLL0[15:8]							
0x011E	M0_DEN_DPLL0[23:16]							

Table 64. DPLL-0 Feedback Divider M0 Register Descriptions

Bit Field Name	Field Type	Default Value	Description
M0_NUM_DPLL0[23:0]	R/W	0x000	Numerator portion of the fractional feedback divider of DPLL-0 for input clock 0 (CLK_0), (binary coding)
M0_DEN_DPLL0[23:0]	R/W	0x800000	Denominator portion of the fractional feedback divider of DPLL-0 for input clock 0 (CLK_0), (binary coding)

DPLL-0 Frequency Control

Table 65. DPLL-0 Frequency Control Register Locations

Address	D7	D6	D5	D4	D3	D2	D1	D0
0x0120	REF_SEL_MODE_DPLL0[1:0]		REF_MAN_SEL_DPLL0	FB_SEL_DPLL0	REF_PRIORITY_DPLL0	REVERTIVE_EN_DPLL0	HITLESS_EN_DPLL0	TIE_CLR_DPLL0

Table 66. DPLL-0 Frequency Control Register Descriptions

Bit Field Name	Field Type	Default Value	Description
REF_SEL_MODE_DPLL0[1:0]	R/W	01	Reference Selection for DPLL-0 00 = Pin selection, follow CLK_n_SEL[1:0] through GPIO pins 01 = Manual selection, follow ref_man_select_cfg 10 = Auto selection, select based on CLK_n qualities and priorities 11 = Same as 00
REF_MAN_SEL_DPLL0	R/W	0	Selection of the DPLL-0 reference to TDC 0 = CLK_0 1 = CLK_1
FB_SEL_DPLL0	R/W	0	Selection of the DPLL-0 feedback clock 0 = DPLL-0 feedback divider 1 = CLK_1 When this bit is set to 1, the phase detector can be used to measure two input clocks. In this case DPLL-0 should be manually set to select CLK-0. It can also be used for external loopback by connecting one of the DPLL-0 output to CLK_1.
REF_PRIORITY_DPLL0	R/W	0	This bit sets the priority of the clock 0 = CLK_0 higher priority 1 = CLK_1 higher priority
REVERTIVE_EN_DPLL0	R/W	0	This bit sets the revertive and non-revertive reference switching 0 = Non-revertive 1 = Revertive
HITLESS_EN_DPLL0	R/W	0	This bit enable/disable hitless reference switching 0 = Disable 1 = Enable
TIE_CLR_DPLL0	WC	0	If TIE_CLR_DPLL0 is set to 1, then the stored phase error is cleared, and DPLL0 output phase will align to the input reference. It is self-cleared.

DPLL-0 Lock Timer

Table 67. DPLL-0 Lock Timer Register Locations

Address	D7	D6	D5	D4	D3	D2	D1	D0
0x0121	DPLL0_LOCK_TIMER[7:0]							
0x0122	DPLL0_LOCK_TIMER[15:8]							

Table 68. DPLL-0 Lock Timer Register Descriptions

Bit Field Name	Field Type	Default Value	Description
DPLL0_LOCK_TIMER[15:0]	R/W	0x00FF	16-bit unsigned Lock timer = LOCK_TIMER_DPLL0[15:0]×2ms If phase error is within the lock_threshold for the time set in this register, DPLL-0 declares lock

DPLL-0 Hitless Switch

Table 69. DPLL-0 Hitless Switch Bit Field Locations

Address	D7	D6	D5	D4	D3	D2	D1	D0
0x0123	HITLESS_BW_SHIFT_DPLL0[4:0]					HITLESS_AVG_DPLL0[2:0]		

Table 70. DPLL-0 Mode Control Bit Descriptions

Bit Field Name	Field Type	Default Value	Description
HITLESS_BW_SHIFT_DPLL0[4:0]	R/W	0x0E	DPLL-0 hitless switch, the bandwidth shift value
HITLESS_AVG_DPLL0[2:0]	R/W	5	DPLL-0 hitless switch, the phase offset is averaged for 2 ^{hitless_avg} cycles of the (new) input clock

DPLL-0 Mode Control

Table 71. DPLL-0 Mode Control Bit Field Locations

Address	D7	D6	D5	D4	D3	D2	D1	D0
0x0124	PH_STS_SELECT_DPLL0	WRITE_PHASE_EN_DPLL0	WRITE_FREQUENCY_EN_DPLL0	Reserved	Reserved	DPLL_STATE_DPLL0[2:0]		
0x0125	FILTER_STS_SELECT_DPLL0[1:0]	SYSCOMBO_MODE_EN_DPLL0		COMBO_MODE_EN_DPLL0	Reserved	Reserved	Reserved	WRITE_TIMER_TRIG_DPLL0
0x0126	Reserved					FREQ_ON_TIME_OUT	FAIL_HOLD_DPLL0	DIRECT_WRITE_MODE_DPLL0

Table 72. DPLL-0 Mode Control Bit Descriptions

Bit Field Name	Field Type	Default Value	Description
PH_STS_SELECT_DPLL0	R/W	0	Selects source of the phase status register 0 = From decimator 1 = From TDC
WRITE_PHASE_EN_DPLL0	R/W	0	This bit programs the device in write phase mode. 0 = Normal DPLL mode, TDC phase get in to DPLL-0 1 = Write_phase mode enable
WRITE_FREQUENCY_EN_DPLL0	R/W	0	This bit programs the device in write frequency mode. 0 = Normal DPLL-0 mode 1 = Write_frequency mode enable, set FCW to the value set in register WRITE_FREQUENCY_CNFG
DPLL_STATE_DPLL0[2:0]	R/W	5	DPLL-0 state Configuration: 000 = Freerun 001 = Lock acquisition 010 = Lock 011 = Holdover 100 = Lock recovery 101 = Auto state machine (freerun/acq1/lock/holdover/acq2) Others = Freerun
FILTER_STS_SELECT_DPLL0[1:0]	R/W	0	Selects source of the filter status register 00 = Integrator 10 = Proportional + integrator 01 = Holdover value 11 = fcw
SYSCOMBO_MODE_EN_DPLL0	R/W	0	Enable SYS-DPLL combo mode (add frequency control word from SysDPLL) 0 = Disable 1 = Enable syscombo mode

Table 72. DPLL-0 Mode Control Bit Descriptions (Cont.)

Bit Field Name	Field Type	Default Value	Description
COMBO_MODE_EN_DPLL0	R/W	0	Combo mode enable/disable Enable frequency control word from DPLL-1 0 = Disable 1 = Enable
WRITE_TIMER_TRIG_DPLL0	WC	0	Write 1 to this bit will start the write_timer. This bit is self clear
FREQ_ON_TIMEOUT	R/W	0	When the write timer expires, the value that is set in the DCO can be either the holdover value or the DCO can be set to zero. If FREQ_ON_TIMEOUT is zero, then when the write timer expires, the holdover value will be used and it is dependent on the holdover state If FREQ_ON_TIMEOUT is 1, then when the write timer expires, the DCO value is set to zero.
FAIL_HOLD_DPLL0	R/W	1	fail_hold 0 = If the DPLL is programmed in lock acquisition, or lock recovery, or locked/normal state, and if the input clock fails, then the DPLL will stay in the programmed state (Lock acquisition, or Lock recovery, or Locked/normal state). 1 = If the DPLL is programmed in lock acquisition, or Lock recovery, or Locked/Normal state, and if the input clock fails, then the DPLL will go to holdover state.
DIRECT_WRITE_MODE_DPLL0	R/W	1	direct_write_mode: 0 = Write_phase and write_frequency active after write_timer is triggered and inactive when time out 1 = Write_phase and write_frequency active right after being written, write_timer is not involved in this mode.

DPLL-0 Phase Offset, Write Phase and Frequency

Table 73. DPLL-0 Phase Offset, Write Phase and Frequency Bit Field Locations

Address	D7	D6	D5	D4	D3	D2	D1	D0
0x0127	PHASE_OFFSET_DPLL0[7:0]							
0x0128	PHASE_OFFSET_DPLL0[15:8]							
0x0129	PHASE_OFFSET_DPLL0[23:16]							
0x012A	PHASE_OFFSET_DPLL0[31:24]							
0x012B	Reserved				PHASE_OFFSET_DPLL0[35:32]			
0x012C	WRITE_PHASE_DPLL0[7:0]							
0x012D	WRITE_PHASE_DPLL0[15:8]							
0x012E	WRITE_PHASE_DPLL0[23:16]							
0x012F	WRITE_PHASE_DPLL0[31:24]							
0x0130	WRITE_FREQUENCY_DPLL0[7:0]							
0x0131	WRITE_FREQUENCY_DPLL0[15:8]							
0x0132	WRITE_FREQUENCY_DPLL0[23:16]							
0x0133	WRITE_FREQUENCY_DPLL0[31:24]							
0x0134	WRITE_FREQUENCY_DPLL0[39:32]							
0x0135	Reserved						WRITE_FREQUENCY_DPLL0[41:40]	
0x0136	WRITE_TIMER_DPLL0[7:0]							
0x0137	WRITE_TIMER_DPLL0[15:8]							

Table 74. DPLL-0 Phase Offset, Write Phase and Frequency Bit Field Descriptions

Bit Field Name	Field Type	Default Value	Description
PHASE_OFFSET_DPLL0[35:0]	R/W	0	Phase offset to adjust the phase offset between the feedback and clock input. 36-bit 2's complement LSB = 1 TDC step, which is $T_{SYSAPLL_VCO} / 62$ (period of the SYS-APLL VCO divided by 62)
WRITE_PHASE_DPLL0[31:0]	R/W	0	In write phase mode, set the phase through this register. Write phase bits[31:0]. 32-bit 2's complement LSB = 1 TDC step, which is $T_{SYSAPLL_VCO} / 62$ (period of the SYS-APLL VCO divided by 62)

Table 74. DPLL-0 Phase Offset, Write Phase and Frequency Bit Field Descriptions (Cont.)

Bit Field Name	Field Type	Default Value	Description
WRITE_FREQUENCY_DPLL0[41:0]	R/W	0	In write frequency mode, set DCO frequency through this register. Write frequency bits[41:0]. 42-bit 2's complement LSB = 2^{-53} max= ± 244 ppm
WRITE_TIMER_DPLL0[15:0]	R/W	0	This timer sets the total time that WRITE_PHASE_DPLL0 or WRITE_FREQUENCY_DPLL0 takes effect. 16-bit, unsigned These bits set the total time to a multiple of 125us. When the write timer expires, the value that is set in the DCO can be either the holdover value or the DCO can be set to zero depending on the setting of FREQ_ON_TIMEOUT bit.

DPLL-0 Reference State

Table 75. DPLL-0 Reference State Bit Field Locations and Descriptions

Address	D7	D6	D5	D4	D3	D2	D1	D0
0x0138	Reserved	WRITE_TIMER_ACTIVE_STS_DPLL0	CURRENT_REF_STS_DPLL0[1:0]		LOCK_STS_DPLL0	DPLL_STATE_STS_DPLL0[2:0]		
0x0139	FILTER_STS_DPLL0[7:0]							
0x013A	FILTER_STS_DPLL0[15:8]							
0x013B	FILTER_STS_DPLL0[23:16]							
0x013C	FILTER_STS_DPLL0[31:24]							
0x013D	FILTER_STS_DPLL0[39:32]							
0x013E	FILTER_STS_DPLL0[47:40]							
0x013F	PHASE_STS_DPLL0[7:0]							
0x0140	PHASE_STS_DPLL0[15:8]							
0x0141	PHASE_STS_DPLL0[23:16]							
0x0142	PHASE_STS_DPLL0[31:24]							
0x0143	Reserved				PHASE_STS_DPLL0[35:32]			

Table 76. DPLL-0 Reference State Bit Field Locations and Descriptions

Bit Field Name	Field Type	Default Value	Description
WRITE_TIMER_ACTIVE_STS_DPLL0	R/O	0	Indicate write timer active 0 = Time out 1 = Not time out (indicates write_phase/write_frequency is in process)
CURRENT_REF_STS_DPLL0[1:0]	R/O	0	Indicate current selected ref 00 = CLK-0 01 = CLK-1 Others = No ref selected
LOCK_STS_DPLL0	R/O	0	dpll lock status 0 = Unlock 1 = Locked
DPLL_STATE_STS_DPLL0[2:0]	R/O	0	dpll states: 000 = Freerun 001 = Lock acquisition 010 = Normal lock 011 = Holdover 100 = Lock recovery
FILTER_STS_DPLL0[47:0]	R/O	0	DPLL-0 filter status controlled by FILTER_STS_SELECT_DPLL0. 48-bit 2's complement LSB = 2^{-53} Report DPLL-0 filter status according to FILTER_STS_SELECT_DPLL0.
PHASE_STS_DPLL0[35:0]	R/O	0	DPLL-0 phase status. 36-bit 2's complement LSB = $T_{\text{SYSAPLL_VCO}} / 62$ Current phase data from decimator or TDC selected by PH_STS_SELECT_DPLL0 bit.

DPLL-0 Lock Threshold, Lock Timer, Bandwidth

Table 77. DPLL-0 Lock Threshold, Lock Timer, Bandwidth Bit Field Locations and Descriptions

Address	D7	D6	D5	D4	D3	D2	D1	D0
0x0144	LOCK_THRESHOLD_DPLL0[7:0]							
0x0145	LOCK_THRESHOLD_DPLL0[15:8]							
0x0146	FREQ_SNAP_SLOPE_DPLL0[7:0]							
0x0147	AA_BW_SHIFT_DPLL0[4:0]				AA_BW_MULT_DPLL0[2:0]			
0x0148	NORMAL_BW_SHIFT_DPLL0[4:0]				NORMAL_BW_MULT_DPLL0[2:0]			
0x0149	Reserved		NORMAL_DAMPING_SHIFT_DPLL0[2:0]		NORMAL_DAMPING_MULT_DPLL0[2:0]			
0x014A	ACQ_BW_SHIFT_DPLL0[4:0]				ACQ_BW_MULT_DPLL0[2:0]			
0x014B	Reserved		ACQ_DAMPING_SHIFT_DPLL0[2:0]		ACQ_DAMPING_MULT_DPLL0[2:0]			

Table 78. DPLL-0 Lock Threshold, Lock Timer, Bandwidth Bit Field Locations and Descriptions

Bit Field Name	Field Type	Default Value	Description
LOCK_THRESHOLD_DPLL0[15:0]	R/W	0x155	DPLL-0 lock detector threshold 16-bit, unsigned $LSB = T_{SYSAPLL_VCO} / 62$
FREQ_SNAP_SLOPE_DPLL0[7:0]	R/W	0x20	Frequency snap slope limit 8-bit unsigned $LSB \text{ of } 2^{-40} \times 8000 \times 10^6 \text{ ppm/s.}$ If these bits are set to 0, then the frequency snap slope limit is unlimited.
AA_BW_SHIFT_DPLL0[4:0]	R/W	0xF	Anti alias shift. Anti aliasing filter bandwidth = $coe \times f / (2\pi)$ where, $coe = 2^{-(18-AA_BW_SHIFT_DPLL0)} \times AA_BW_MULT_DPLL0/8$ $f = \text{fb frequency}$ if AA_BW_MULT_DPLL0=0, then the anti aliasing filter is bypassed
AA_BW_MULT_DPLL0[2:0]	R/W	4	Anti alias multi. See AA_BW_SHIFT_DPLL0[4:0] description.
NORMAL_BW_SHIFT_DPLL0[4:0]	R/W	0x12	Normal bandwidth shift. Normal bandwidth shift and mult must be < 24 for stability $BW = (K_{TDC} \times K_{PEC} \times K_P) / 2\pi$ Where: $K_{TDC} = 1 / T_{DC_STEP}$ $T_{DC_STEP} = T_{SYSAPLL_VCO} / 62 \text{ (in ps)}$ $K_{PEC} = 2^7$ $K_P = (NORMAL_BW_SHIFT_DPLL0/4) \times 2^{(NORMAL_BW_SHIFT_DPLL0-53)}$
NORMAL_BW_MULT_DPLL0[2:0]	R/W	4	Normal bandwidth mult. See NORMAL_BW_SHIFT_DPLL0[4:0] description.

Table 78. DPLL-0 Lock Threshold, Lock Timer, Bandwidth Bit Field Locations and Descriptions (Cont.)

Bit Field Name	Field Type	Default Value	Description
NORMAL_DAMPING_SHIFT_DPLL0[2:0]	R/W	4	Normal damping shift The estimation for Gpeak is: $G_{peak}(dB) = 0.012 \times 2^{(NORMAL_DAMPING_SHIFT_DPLL0-1)} \times NORMAL_DAMPING_MULT_DPLL0/4$ --- assuming filter update rate is 562.5kHz. if update rate doubles, then Gpeak doubles
NORMAL_DAMPING_MULT_DPLL0[2:0]	R/W	5	Normal damping mult. See NORMAL_DAMPING_SHIFT_DPLL0[2:0] description.
ACQ_BW_SHIFT_DPLL0[4:0]	R/W	0x16	Acquire bandwidth shift. Acquire bandwidth shift and mult: <24 for stability, $BW = (K_{TDC} \times K_{PEC} \times K_P) / 2\pi$ Where: $K_{TDC} = 1e12 / T_{DC_STEP}$ $T_{DC_STEP} = T_{SYSAPLL_VCO} / 62$ (in ps) $K_{PEC} = 2^7$ $K_P = (ACQ_BW_MULT_DPLL0/4) \times 2^{(ACQ_BW_SHIFT_DPLL0-53)}$
ACQ_BW_MULT_DPLL0[2:0]	R/W	4	Acquire bandwidth mult. See ACQ_BW_SHIFT_DPLL0[4:0] description.
ACQ_DAMPING_SHIFT_DPLL0[2:0]	R/W	4	Acquire damping bandwidth shift The estimation for Gpeak is: $G_{peak}(dB) = 0.012 \times 2^{(ACQ_DAMPING_SHIFT_DPLL0-1)} \times ACQ_DAMPING_MULT_DPLL0/4$ --- assuming filter update rate is 562.5kHz. if update rate doubles, then Gpeak doubles
ACQ_DAMPING_MULT_DPLL0[2:0]	R/W	5	Acquire damping bandwidth mult See ACQ_DAMPING_SHIFT_DPLL0[4:0] description.

DPLL-0 Phase Slope Limiting

Table 79. DPLL-0 Phase Slope Limiting Bit Field Locations

Address	D7	D6	D5	D4	D3	D2	D1	D0
0x014C	PHASE_SLOPE_LIMIT_DPLL0[7:0]							
0x014D	PHASE_SLOPE_LIMIT_DPLL0[15:8]							
0x014E	PHASE_SLOPE_LIMIT_DPLL0[23:16]							
0x014F	Reserved	PHASE_SLOPE_LIMIT_DPLL0[30:24]						
0x0150	INTEGRATOR_LIMIT_DPLL0[7:0]							
0x0151	INTEGRATOR_LIMIT_DPLL0[15:8]							
0x0152	INTEGRATOR_LIMIT_DPLL0[23:16]							
0x0153	Reserved	INTEGRATOR_LIMIT_DPLL0[30:24]						

Table 80. DPLL-0 Phase Slope Limiting Bit Field Descriptions

Bit Field Name	Field Type	Default Value	Description
PHASE_SLOPE_LIMIT_DPLL0[30:0]	R/W	0x7FFFFFFF	DPLL phase slope limit configuration. These bits are used to limit the phase slope of the DPLL output. 31-bit unsigned LSB = $2^{-37} \times 10^6$ (us/s)
INTEGRATOR_LIMIT_DPLL0[30:0]	R/W	0x7FFFFFFF	These bits are used to program the pull-in range of the DPLL. 31-bit, unsigned LSB = $2^{-43} \times 10^6$ (ppm) max = $2^{31} \times 2^{-43} \times 10^6 = 244$ ppm

DPLL-0 Holdover, Phase Error Compensation (PEC)

Table 81. DPLL-0 Holdover, Phase Error Compensation Bit Field Locations and Descriptions

Address	D7	D6	D5	D4	D3	D2	D1	D0
0x0154	HOLDOVER_BW_SHIFT_DPLL0[4:0]					HOLDOVER_MULT_DPLL0[2:0]		
0x0155	HOLDOVER_MODE_DPLL0[1:0]		HOLDOVER_HISTORY_DPLL0[5:0]					
0x0156	HOLDOVER_VALUE_DPLL0[7:0]							
0x0157	HOLDOVER_VALUE_DPLL0[15:8]							
0x0158	HOLDOVER_VALUE_DPLL0[23:16]							
0x0159	HOLDOVER_VALUE_DPLL0[31:24]							
0x015A	HOLDOVER_VALUE_DPLL0[39:32]							
0x015B	Reserved						HOLDOVER_VALUE_DPLL0[41:40]	
0x015C	PEC_CLK0_CORR_DPLL0[7:0]							
0x015D	Reserved		PEC_CLK0_CORR_DPLL0[13:8]					
0x015E	PEC_CLK1_CORR_DPLL0[7:0]							
0x015F	Reserved		PEC_CLK1_CORR_DPLL0[13:8]					

Table 82. DPLL-0 Holdover, Phase Error Compensation Bit Field Locations and Descriptions

Bit Field Name	Field Type	Default Value	Description
HOLDOVER_BW_SHIFT_DPLL0[4:0]	R/W	8	DPLL-0 Holdover filter bandwidth shift. Holdover filter bandwidth = $coe \times f / (2\pi)$ where $coe = 2^{-(33-HOLDOVER_BW_SHIFT_DPLL0)} \times HOLDOVER_MULT_DPLL0 / 4$ f = DPLL-0 update rate If coe = 0, the filter is bypassed
HOLDOVER_MULT_DPLL0[2:0]	R/W	4	DPLL-0 Holdover filter bandwidth multiplier See HOLDOVER_BW_SHIFT_DPLL0[4:0] description.
HOLDOVER_MODE_DPLL0[1:0]	R/W	0	00 = Instantaneous 01 = History instantaneous 10 = Manual holdover 11 = History averaged
HOLDOVER_HISTORY_DPLL0[5:0]	R/W	0	Set holdover history from 1s to 64s 0 = Averaged value of 1s before 1 = Averaged value of 2s before ... 63 = Averaged value of 64s before
HOLDOVER_VALUE_DPLL0[41:0]	R/W	0	The value for manual holdover frequency. 42-bit, 2's complement LSB = 2^{-53} Max = ± 244 ppm

Table 82. DPLL-0 Holdover, Phase Error Compensation Bit Field Locations and Descriptions (Cont.)

Bit Field Name	Field Type	Default Value	Description
PEC_CLK0_CORR_DPLL0[13:0]	R/W	0x55	<p>Phase error cancellation (PEC) to compensate the phase error from the 1st-order modulated fractional feedback divider. The residual part of the fractional feedback is scaled to TDC resolution and is compensated to the TDC phase error.</p> <p>PEC scale factor for using CLK_0 as input: $PEC_CORR = (T_{VCO} \div T_{DC_STEP}) \times 2^{DEN_BITS/DEN}$ where: T_{VCO}: period of the feedback divider input clock T_{DC_STEP}: TDC step size DEN_BITS: total number of bits of denominator bits (24 bits) DEN: denominator (M0_DEN_DPLL0[23:0])</p>
PEC_CLK1_CORR_DPLL0[13:0]	R/W	0x55	<p>Phase error cancellation (PEC) to compensate the phase error from the 1st-order modulated fractional feedback divider. The residual part of the fractional feedback is scaled to TDC resolution and is compensated to the TDC phase error.</p> <p>PEC scale factor for using CLK_1 as input: $PEC_CORR = (T_{VCO} \div T_{DC_STEP}) \times 2^{DEN_BITS/DEN}$ where: T_{VCO}: period of the feedback divider input clock T_{DC_STEP}: TDC step size DEN_BITS: total number of bits of denominator bits (24 bits) DEN: denominator (M1_DEN_DPLL0[23:0])</p>

DPLL-0 Fractional Feedback Divider M1

Table 83. DPLL-0 Feedback Divider M1 Divider Bit Field Locations

Offset Address (Hex)	D7	D6	D5	D4	D3	D2	D1	D0
0x0160	R0_DPLL0[7:0]							
0x0161	Reserved						R0_DPLL0[9:8]	
0x0162	R1_DPLL0[7:0]							
0x0163	Reserved						R1_DPLL0[9:8]	
0x0164	M1_INT_DPLL0[7:0]							
0x0165	M1_INT_DPLL0[15:8]							
0x0166	M1_INT_DPLL0[23:16]							
0x0167	M1_INT_DPLL0[31:24]							
0x0169	M1_NUM_DPLL0[7:0]							
0x016A	M1_NUM_DPLL0[15:8]							
0x016B	M1_NUM_DPLL0[23:16]							
0x016C	M1_DEN_DPLL0[7:0]							
0x016D	M1_DEN_DPLL0[15:8]							
0x016E	M1_DEN_DPLL0[23:16]							

Table 84. DPLL-0 Feedback Divider M1 Divider Bit Field Descriptions

Bit Field Name	Field Type	Default Value	Description
R0_DPLL0[9:0]	R/W	0	CK0 pre-divider Pre-Divider is 10-bit and it can divide from 1 to $2^{10}-1$.
R1_DPLL0[9:0]	R/W	0	CK1 pre-divider Pre-Divider is 10-bit and it can divide from 1 to $2^{10}-1$.
M1_INT_DPLL0[31:0]	R/W	0xA00	Integer portion of the fractional feedback divider of DPLL-0 for input clock 1 (CK1)
M1_NUM_DPLL0[23:0]	R/W	0x000	Numerator portion of the fractional feedback divider of DPLL-0 for input clock 1 (CK1)
M1_DEN_DPLL0[23:0]	R/W	0x800000	Denominator portion of the fractional feedback divider of DPLL-0 for input clock 1 (CK1)

DPLL-1 (APLL-1) Frequency Configuration

Table 85. DPLL-1 (APLL-1) Frequency Configuration Field Locations

Address	D7	D6	D5	D4	D3	D2	D1	D0	
0x0180	M_INT_APLL1[7:0]								
0x0181	Reserved						M_INT_APLL1[9:8]		
0x0182	M0_INT_DPLL1[7:0]								
0x0183	M0_INT_DPLL1[15:8]								
0x0184	M0_INT_DPLL1[23:16]								
0x0185	M0_INT_DPLL1[31:24]								
0x0186	1	1	Reserved					FB_SEL_DPLL1_RF	
0x0187	PD_APLL1	PD_PFD_APLL1	PD_FB_APLL1	PD_FB_DPLL1	PD_P1	Reserved			
0x0188	M_NUM_APLL1[7:0]								
0x0189	M_NUM_APLL1[15:8]								
0x018A	M_NUM_APLL1[23:16]								
0x018C	M_DEN_APLL1[7:0]								
0x018D	M_DEN_APLL1[15:8]								
0x018E	M_DEN_APLL1[23:16]								
0x0190	CAL_REF_APLL1[7:0]								
0x0191	CAL_EN_APLL1	Reserved	CAL_REF_APLL1[13:8]						
0x0192	Reserved		P1[6:0]						

Table 86. DPLL-1 (APLL-1) Frequency Configuration Field Descriptions

Bit Field Name	Field Type	Default Value	Description
M_INT_APLL1[9:0]	R/W	0x028	Integer portion of the fractional feedback divider of APLL-1 (binary coding).
M0_INT_DPLL1[31:0]	R/W	0xFBA	Integer portion of the fractional feedback divider of DPLL-1 for input clock 0 (REF0), (binary coding)
FB_SEL_DPLL1_RF	R/W	0	Feedback select for DPLL-1 fractional vs RF 0 = Selects DPLL1 FRAC FB divider 1 = Selects 2 ^N RF FB divider
PD_APLL1	R/W	0	Power down APLL-1 (except VCO of APLL-1) 0 = Power up 1 = Power down
PD_PFD_APLL1	R/W	0	Power down APLL-1 phase frequency detector 0 = Power up 1 = Power down

Table 86. DPLL-1 (APLL-1) Frequency Configuration Field Descriptions (Cont.)

Bit Field Name	Field Type	Default Value	Description
PD_FB_APLL1	R/W	0	Power down APLL-1 feedback divider M 0 = Power up 1 = Power down
PD_FB_DPLL1	R/W	1	Power down DPLL-1 feedback divider M0, M1 0 = Power up 1 = Power down
PD_P1	R/W	0	Power down P0 (post-divider of APLL-1) 0 = Power up 1 = Power down
M_NUM_APLL1[23:0]	R/W	0x600000	Numerator portion of the fractional feedback divider of APLL-0 (binary coding).
M_DEN_APLL1[23:0]	R/W	0x640000	Denominator portion of the fractional feedback divider of APLL-0 (binary coding)
CAL_REF_APLL1[13:0]	R/W	0x3E8	APLL-1 Calibration reference frequency divider $CAL_REF_APLL1[13:0] = 16384 \times f_{APLL1_REF} / (2 \times f_{VCO} \times 10\%)$ f_{APLL1_REF} is the reference frequency of APLL-1 (OSCI/OSCO or XO_DPLL).
CAL_EN_APLL1	R/W	1	APLL-1 calibration (VCO band selection) enable 0 = Calibration is disabled 1 = Calibration is enabled
P1[6:0]	R/W	0x08	APLL-1 Post Divider (binary coding) Divides the output frequency of APLL-1 to a lower value. Use this divider, together with the ± 2 dividers in the signal path from the VCO (APLL-1), to lower the value of the VCO frequency (3932.16MHz) routed to the RF-PLL or to APLL-2 to a frequency less than 250MHz (less than 160MHz if APLL-2 is in fractional mode and its source is APLL-1).

DPLL-1 (APLL-1) DSM Control and APLL-1 Charge Pump Configuration

Table 87. DPLL-1 (APLL-1) DSM Control and APLL-1 Charge Pump Locations and Descriptions

Address	D7	D6	D5	D4	D3	D2	D1	D0
0x0194	Reserved	DSM_DITH_EN_APLL1	DSM_DITH_NS_APLL1	DSM_DITH_GAIN_APLL1[1:0]		DSM_ORDER_APLL1[1:0]		Reserved
0x0195	EN_CP_APLL1	Reserved	ICP_OFFSET_APLL1[5:0]					
0x0196	GBOOST_APLL1[3:0]			EN_CPC_APLL1[3:0]				
0x0197	SOURCE_APLL1[3:0]			SINK_APLL1[3:0]				

Table 88. DPLL-1 (APLL-1) DSM Control and Charge Pump Locations and Descriptions

Bit Field Name	Field Type	Default Value	Description
DSM_DITH_EN_APLL1	R/W	0	Dither enable for DSM of APLL-1. Value will be determined by Renesas. 0 = Dither off 1 = Dither on
DSM_DITH_NS_APLL1	R/W	0	Noise shaping for APLL-1 DSM. Value will be determined by Renesas. 0 = Dither not shaped 1 = Dither shaped
DSM_DITH_GAIN_APLL1[1:0]	R/W	0	Gain control for APLL-1 DSM. Value will be determined by Renesas. 00 = LSB 01 = 2×LSB 10 = 4×LSB 11 = 8×LSB
DSM_ORDER_APLL1[1:0]	R/W	3	Order for the APLL-1 DSM. Will be determined by Renesas. 00 = No accum 01 = First order 10 = Second order 11 = Third order
EN_CP_APLL1	R/W	1	APLL-1 enable charge pump 0 = Disable charge pump current 1 = Enable charge pump current
ICP_OFFSET_APLL1[5:0]	R/W	0x20	APLL-1 programmable charge pump offset output current. ICP_OFFSET_APLL1 is an additive current applied to ICP_APLL1 effectively introducing a phase offset into the APLL-1. Use ICP_OFFSET_APLL1 to improve charge pump linearity and APLL-1 phase noise. Offset current is programmable between 12.5µA and 487.5µA in 12.5µA steps. $ICP = ICP_OFFSET_APLL1[0] \times 12.5\mu A + ICP_OFFSET_APLL1[1] \times 25\mu A + ICP_OFFSET_APLL1[2] \times 50.0\mu A + ICP_OFFSET_APLL1[3] \times 100\mu A + ICP_OFFSET_APLL1[4] \times 100\mu A + ICP_OFFSET_APLL1[5] \times 200\mu A$
GBOOST_APLL1[3:0]	R/W	0xF	APLL-1 Programmable reference voltage setting the voltage drops across the gain boosted cascode circuits. Value will be determined by Renesas.

Table 88. DPLL-1 (APLL-1) DSM Control and Charge Pump Locations and Descriptions (Cont.)

Bit Field Name	Field Type	Default Value	Description
EN_CPC_APLL1[3:0]	R/W	0xF	<p>The charge pump of APLL-1 contains of the parallel connection of identical 4 cores. When set to 1, each bit enables one charge pump core. Enabled charge pump cores are additive.</p> <p>0000 = no charge pump core enabled</p> <p>...</p> <p>1111 = 4 charge pump cores are enabled</p> <p>The APLL-1 charge pump current is programmable between 0μA and 2mA (source current) and in between 0μA to 500μA (sink current).</p> <p>APLL-1 source current (ICP_APLL-1):</p> $= 500\mu\text{A} \times (\text{EN_CPC_APLL1}[0] \times \text{SOURCE_APLL1}[0] + \text{EN_CPC_APLL1}[1] \times \text{SOURCE_APLL1}[1] + \text{EN_CPC_APLL1}[2] \times \text{SOURCE_APLL1}[2] + \text{EN_CPC_APLL1}[3] \times \text{SOURCE_APLL1}[3])$ <p>APLL-1 sink current (ICP_APLL-1):</p> $= 250\mu\text{A} \times (\text{EN_CPC_APLL1}[0] \times \text{SINK_APLL1}[0] + \text{EN_CPC_APLL1}[1] \times \text{SINK_APLL1}[1] + \text{EN_CPC_APLL1}[2] \times \text{SINK_APLL1}[2] + \text{EN_CPC_APLL1}[3] \times \text{SINK_APLL1}[3])$
SOURCE_APLL1[3:0]	R/W	0xF	<p>APLL-1 individual charge pump source current enable.</p> <p>Each bit is defined as:</p> <p>0 = Charge pump n (n=0 to 3) source current disabled</p> <p>1 = Charge pump n (n=0 to 3) source current enabled</p>
SINK_APLL1[3:0]	R/W	0	<p>APLL-1 individual charge pump sink current enable.</p> <p>Each bit is defined as:</p> <p>0 = Charge pump n (n=0 to 3) sink current disabled</p> <p>1 = Charge pump n (n=0 to 3) sink current enabled</p>

Table 89. DPLL-1 Frequency Control Bit Locations

Address	D7	D6	D5	D4	D3	D2	D1	D0
0x0198	M0_NUM_DPLL1[7:0]							
0x0199	M0_NUM_DPLL1[15:8]							
0x019A	M0_NUM_DPLL1[23:16]							
0x019C	M0_DEN_DPLL1[7:0]							
0x019D	M0_DEN_DPLL1[15:8]							
0x019E	M0_DEN_DPLL1[23:16]							
0x01A0	REF_SEL_MODE_DPLL1[1:0]	REF_MAN_SEL_DPLL1	FB_SEL_DPLL1	REF_PRIORITY_DPLL1	REVERTIVE_EN_DPLL1	HITLESS_EN_DPLL1	TIE_CLR_DPLL1	

Table 90. DPLL-1 Frequency Control Bit Field Descriptions

Bit Field Name	Field Type	Default Value	Description
M0_NUM_DPLL1[23:0]	R/W	0x33F000	Numerator portion of the fractional feedback divider of DPLL-1 for input clock 0 (REF0), (binary coding)
M0_DEN_DPLL1[23:0]	R/W	0x61A800	Denominator portion of the fractional feedback divider of DPLL-1 for input clock 0(REF0), (binary coding)
REF_SEL_MODE_DPLL1[1:0]	R/W	1	Reference Selection for DPLL-1 00 = Pin selection, follow CLK_n_SEL[1:0] through GPIO pins 01 = Manual selection, follow REF_MAN_SEL_DPLL1 10 = Auto selection, select based on CLK_n qualities and priorities 11 = Same as 00
REF_MAN_SEL_DPLL1	R/W	1	Selection of the DPLL-1 reference to TDC 0 = CLK_0 1 = CLK_1
FB_SEL_DPLL1	R/W	0	Selection of the DPLL-1 feedback clock 0 = Selects per FB_SEL_DPLL1_RF 1 = CLK_1 When this bit is set to 1, the phase detector can be used to measure two input clocks. In this case DPLL-1 should be manually set to select CLK-0. It can also be used for external loopback by connecting one of the DPLL-1 output to CLK_1.
REF_PRIORITY_DPLL1	R/W	0	This bit sets the priority of the clock. 0 = CLK_0 higher priority 1 = CLK_1 higher priority
REVERTIVE_EN_DPLL1	R/W	0	This bit sets the revertive and non-revertive reference switching. 0 = Non-revertive 1 = Revertive
HITLESS_EN_DPLL1	R/W	0	This bit enable/disable hitless reference switching. 0 = Disable 1 = Enable
TIE_CLR_DPLL1	WC	0	If TIE_CLR_DPLL1 is set to 1, then the stored phase error is cleared, and DPLL1 output phase will align to the input reference. It is self-cleared.

DPLL-1 Lock Timer

Table 91. DPLL-1 Lock Timer Register Locations

Address	D7	D6	D5	D4	D3	D2	D1	D0
0x01A1	DPLL1_LOCK_TIMER[7:0]							
0x01A2	DPLL1_LOCK_TIMER[15:8]							

Table 92. DPLL-1 Lock Timer Register Descriptions

Bit Field Name	Field Type	Default Value	Description
DPLL1_LOCK_TIMER[15:0]	R/W	0x00FF	16-bit unsigned Lock timer = LOCK_TIMER_DPLL0[15:0] × 2ms If phase error is within the lock_threshold for the time set in this register, DPLL-0 declares lock.

DPLL-1 Hitless Switch

Table 93. DPLL-1 Hitless Switch Bit Field Locations

Address	D7	D6	D5	D4	D3	D2	D1	D0
0x01A3	HITLESS_BW_SHIFT_DPLL1[4:0]					HITLESS_AVG_DPLL1[2:0]		

Table 94. DPLL-1 Mode Control Bit Descriptions

Bit Field Name	Field Type	Default Value	Description
HITLESS_BW_SHIFT_DPLL1[4:0]	R/W	0x0E	DPLL-1 hitless switch, the bandwidth shift value
HITLESS_AVG_DPLL1[2:0]	R/W	5	DPLL-1 hitless switch, the phase offset is averaged for 2^hitless_avg cycles of the (new) input clock

DPLL-1 Mode Control

Table 95. DPLL-1 Mode Control Bit Field Locations

Address	D7	D6	D5	D4	D3	D2	D1	D0
0x01A4	PH_STS_SELECT_DPLL1	WRITE_PHASE_EN_DPLL1	WRITE_FREQUENCY_EN_DPLL1	Reserved	Reserved	DPLL_STATE_DPLL1[2:0]		
0x01A5	FILTER_STS_SELECT_DPLL1[1:0]	SYSCOMBO_MODE_EN_DPLL1		COMBO_MODE_EN_DPLL1	Reserved	Reserved	Reserved	WRITE_TIMER_TRIG_DPLL1
0x01A6	Reserved					FREQ_ON_TIME_OUT	FAIL_HOLD_DPLL1	DIRECT_WRITE_MODE_DPLL1

Table 96. DPLL-1 Mode Control Bit Field Descriptions

Bit Field Name	Field Type	Default Value	Description
PH_STS_SELECT_DPLL1	R/W	0	Selects source of the phase status register. 1 = From TDC 0 = From decimator
WRITE_PHASE_EN_DPLL1	R/W	0	This bit programs DPLL-1 in write phase mode. 0 = Normal DPLL mode, TDC phase get in to DPLL-1 1 = Write_phase mode enable
WRITE_FREQUENCY_EN_DPLL1	R/W	0	This bit programs DPLL-1 in write frequency mode. 0 = Normal DPLL mode 1 = Write_frequency mode enable, set FCW to the value set in register WRITE_FREQUENCY_CNFG
DPLL_STATE_DPLL1[2:0]	R/W	5	DPLL-1 state Configuration: 000 = Freerun 001 = Lock acquisition 010 = Lock 011 = Holdover 100 = Lock recovery 101 = Auto state machine (freerun/acq1/lock/holdover/acq2) Others = Freerun
FILTER_STS_SELECT_DPLL1[1:0]	R/W	0	Selects source of the filter status register 00 = Integrator 10 = Proportional + integrator 01 = Holdover value 11 = fcw
SYSCOMBO_MODE_EN_DPLL1	R/W	0	Enable SYS-DPLL combo mode (add frequency control word from SysDPLL) 0 = Disable 1 = Enable syscombo mode

Table 96. DPLL-1 Mode Control Bit Field Descriptions (Cont.)

Bit Field Name	Field Type	Default Value	Description
COMBO_MODE_EN_DPLL 1	R/W	0	Combo mode enable/disable Enable frequency control word from DPLL-0 0 = Disable 1 = Enable
WRITE_TIMER_TRIG_DPL L1	WC	0	Write 1 to this bit will start the write_timer. This bit is self clear
FREQ_ON_TIMEOUT	R/W	0	When the write timer expires, the value that is set in the DCO can be either the holdover value or the DCO can be set to zero. If FREQ_ON_TIMEOUT is zero, then when the write timer expires, the holdover value will be used and it is dependent on the holdover state If FREQ_ON_TIMEOUT is 1, then when the write timer expires, the DCO value is set to zero.
FAIL_HOLD_DPLL1	R/W	1	fail_hold 0 = If the DPLL is programmed in lock acquisition, or Lock recovery, or Locked/Normal state, and if the input clock fails, then the DPLL will stay in the programmed state (Lock acquisition, or Lock recovery, or Locked/normal state). 1 = If the DPLL is programmed in lock acquisition, or Lock recovery, or Locked/Normal state, and if the input clock fails, then the DPLL will go to holdover state.
DIRECT_WRITE_MODE_D PLL1	R/W	1	direct_write_mode: 0 = Write_phase and write_frequency active after write_timer is triggered and inactive when time out 1 = Write_phase and write_frequency active right after being written, write_timer is not involved in this mode.

DPLL-1 Phase Offset, Write Phase and Frequency

Table 97. DPLL-1 Phase Offset, Write Phase and Frequency Bit Field Locations

Address	D7	D6	D5	D4	D3	D2	D1	D0
0x01A7	PHASE_OFFSET_DPLL1[7:0]							
0x01A8	PHASE_OFFSET_DPLL1[15:8]							
0x01A9	PHASE_OFFSET_DPLL1[23:16]							
0x01AA	PHASE_OFFSET_DPLL1[31:24]							
0x01AB	Reserved				PHASE_OFFSET_DPLL1[35:32]			
0x01AC	WRITE_PHASE_DPLL1[7:0]							
0x01AD	WRITE_PHASE_DPLL1[15:8]							
0x01AE	WRITE_PHASE_DPLL1[23:16]							
0x01AF	WRITE_PHASE_DPLL1[31:24]							
0x01B0	WRITE_FREQUENCY_DPLL1[7:0]							
0x01B1	WRITE_FREQUENCY_DPLL1[15:8]							
0x01B2	WRITE_FREQUENCY_DPLL1[23:16]							
0x01B3	WRITE_FREQUENCY_DPLL1[31:24]							
0x01B4	WRITE_FREQUENCY_DPLL1[39:32]							
0x01B5	Reserved						WRITE_FREQUENCY_DPLL1[41:40]	
0x01B6	WRITE_TIMER_DPLL1[7:0]							
0x01B7	WRITE_TIMER_DPLL1[15:8]							

Table 98. DPLL-1 Phase Offset, Write Phase and Frequency Bit Field Descriptions

Bit Field Name	Field Type	Default Value	Description
PHASE_OFFSET_DPLL1[31:5:0]	R/W	0	Phase offset to adjust the phase offset between the feedback and clock input. 36-bit 2's complement LSB = 1 TDC step, which is $T_{SYSAPLL_VCO} / 62$
WRITE_PHASE_DPLL1[31:0]	R/W	0	In write phase mode, set the phase through this register. Write phase bits[31:0] 32-bit 2's complement LSB = 1 TDC step, which is $T_{SYSAPLL_VCO} / 62$

Table 98. DPLL-1 Phase Offset, Write Phase and Frequency Bit Field Descriptions (Cont.)

Bit Field Name	Field Type	Default Value	Description
WRITE_FREQUENCY_DPLL1[41:0]	R/W	0	In write frequency mode, set DCO frequency through this register. Write frequency bits[41:0] 42-bit 2's complement LSB = 2^{-53} Max = $\pm 244\text{ppm}$
WRITE_TIMER_DPLL1[15:0]	R/W	0	This timer sets the total time that the write_phase or write_frequency takes effect. If time out, then '0' is written in the loop. 16-bit, unsigned These bits set the total time to a multiple of 125us. When the write timer expires, the value that is set in the DCO can be either the holdover value or the DCO can be set to zero depending on the setting of FREQ_ON_TIMEOUT bit.

DPLL-1 Reference State

Table 99. DPLL-1 Reference State Bit Field Locations and Descriptions

Address	D7	D6	D5	D4	D3	D2	D1	D0
0x01B8	Reserved	WRITE_TIMER_ACTIVE_STS_DPLL1	CURRENT_REF_STS_DPLL1[1:0]		LOCK_STS_DPLL1	DPLL_STATE_STS_DPLL1[2:0]		
0x01B9	FILTER_STS_DPLL1[7:0]							
0x01BA	FILTER_STS_DPLL1[15:8]							
0x01BB	FILTER_STS_DPLL1[23:16]							
0x01BC	FILTER_STS_DPLL1[31:24]							
0x01BD	FILTER_STS_DPLL1[39:32]							
0x01BE	FILTER_STS_DPLL1[47:40]							
0x01BF	PHASE_STS_DPLL1[7:0]							
0x01C0	PHASE_STS_DPLL1[15:8]							
0x01C1	PHASE_STS_DPLL1[23:16]							
0x01C2	PHASE_STS_DPLL1[31:24]							
0x01C3	Reserved				PHASE_STS_DPLL1[35:32]			

Table 100. DPLL-1 Reference State Bit Field Locations and Descriptions

Bit Field Name	Field Type	Default Value	Description
WRITE_TIMER_ACTIVE_STS_DPLL1	R/O	0	Indicates write timer active 0 = Time out 1 = Not time out
CURRENT_REF_STS_DPLL1[1:0]	R/O	0	Indicates current selected ref 00 = Ref0 01 = Ref1 Others = No ref selected
LOCK_STS_DPLL1	R/O	0	DPLL lock sts 0 = Unlock 1 = Locked
DPLL_STATE_STS_DPLL1[2:0]	R/O	0	DPLL states. 000 = Freerun 001 = Lock acquisition 010 = Normal lock 011 = Holdover 100 = Lock recovery

Table 100. DPLL-1 Reference State Bit Field Locations and Descriptions (Cont.)

Bit Field Name	Field Type	Default Value	Description
FILTER_STS_DPLL1[47:0]	R/O	0	DPLL-1 filter status controlled by FILTER_STS_SELECT_DPLL1. 48-bit 2's complement LSB = 2^{-53} Report DPLL-1 filter status according to FILTER_STS_SELECT_DPLL1.
PHASE_STS_DPLL1[35:0]	R/O	0	DPLL-1 phase status. 36-bit 2's complement LSB = $T_{\text{SYSAPLL_VCO}} / 62$ Current phase data from decimator or TDC selected by PH_STS_SELECT_DPLL1 bit.

DPLL-1 Lock Threshold, Lock Timer, Bandwidth

Table 101. DPLL-1 Lock Threshold, Lock Timer, Bandwidth Bit Field Locations and Descriptions

Address	D7	D6	D5	D4	D3	D2	D1	D0
0x01C4	LOCK_THRESHOLD_DPLL1[7:0]							
0x01C5	LOCK_THRESHOLD_DPLL1[15:8]							
0x01C6	FREQ_SNAP_SLOPE_DPLL1[7:0]							
0x01C7	AA_BW_SHIFT_DPLL1[4:0]				AA_BW_MULT_DPLL1[2:0]			
0x01C8	NORMAL_BW_SHIFT_DPLL1[4:0]				NORMAL_BW_MULT_DPLL1[2:0]			
0x01C9	Reserved		NORMAL_DAMPING_SHIFT_DPLL1[2:0]			NORMAL_DAMPING_MULT_DPLL1[2:0]		
0x01CA	ACQ_BW_SHIFT_DPLL1[4:0]				ACQ_BW_MULT_DPLL1[2:0]			
0x01CB	Reserved		ACQ_DAMPING_SHIFT_DPLL1[2:0]			ACQ_DAMPING_MULT_DPLL1[2:0]		

Table 102. DPLL-1 Lock Threshold, Lock Timer, Bandwidth Bit Field Locations and Descriptions

Bit Field Name	Field Type	Default Value	Description
LOCK_THRESHOLD_DPLL1[15:0]	R/W	0x0155	DPLL-1 lock detector threshold 16-bit, unsigned LSB = $T_{SYSAPLL_VCO} / 62$
FREQ_SNAP_SLOPE_DPLL1[7:0]	R/W	0x20	Frequency snap slope limit 8-bit unsigned LSB of $2^{-40} \times 8000 \times 10^6$ ppm/s. If these bits are set to 0, then the frequency snap slope limit is unlimited.
AA_BW_SHIFT_DPLL1[4:0]	R/W	0x0A	Anti alias shift. Anti aliasing filter bandwidth = $coe \times f / (2\pi)$ where, $coe = 2^{-(18-AA_BW_SHIFT_DPLL1)} \times AA_BW_MULT_DPLL1/8$ f = fb frequency if AA_BW_MULT_DPLL1=0, then the anti aliasing filter is bypassed
AA_BW_MULT_DPLL1[2:0]	R/W	4	Anti alias multi. See AA_BW_SHIFT_DPLL1[4:0] description.
NORMAL_BW_SHIFT_DPLL1[4:0]	R/W	0x0D	Normal bandwidth shift. Normal bandwidth shift and mult must be < 24 for stability $BW = (K_{TDC} \times K_{PEC} \times K_P) / 2\pi$ Where: $K_{TDC} = 1/T_{DC_STEP}$ $T_{DC_STEP} = T_{SYSAPLL_VCO} / 62$ (in ps) $K_{PEC} = 2^7$ $K_P = (NORMAL_BW_SHIFT_DPLL1/4) \times 2^{(NORMAL_BW_SHIFT_DPLL1-53)}$
NORMAL_BW_MULT_DPLL1[2:0]	R/W	4	Normal bandwidth mult. See NORMAL_BW_SHIFT_DPLL1[4:0] description.

Table 102. DPLL-1 Lock Threshold, Lock Timer, Bandwidth Bit Field Locations and Descriptions (Cont.)

Bit Field Name	Field Type	Default Value	Description
NORMAL_DAMPING_SHIFT_DPLL1[2:0]	R/W	4	Normal damping shift The estimation for Gpeak is: $G_{peak}(dB) = 0.012 \times 2^{(NORMAL_DAMPING_SHIFT_DPLL1-1)} \times NORMAL_DAMPING_MULT_DPLL1/4$ --- assuming filter update rate is 562.5kHz. if update rate doubles, then Gpeak doubles
NORMAL_DAMPING_MULT_DPLL1[2:0]	R/W	4	Normal damping mult. See NORMAL_DAMPING_SHIFT_DPLL1[2:0] description.
ACQ_BW_SHIFT_DPLL1[4:0]	R/W	0x10	Acquire bandwidth shift. Acquire bandwidth shift and mult: <24 for stability, $BW = (K_{TDC} \times K_{PEC} \times K_P) / 2\pi$ Where: $K_{TDC} = 1e12/T_{DC_STEP}$ $T_{DC_STEP} = T_{SYSAPLL_VCO} / 62$ (in ps) $K_{PEC} = 2^7$ $K_P = (ACQ_BW_MULT_DPLL1/4) \times 2^{(ACQ_BW_SHIFT_DPLL1-53)}$
ACQ_BW_MULT_DPLL1[2:0]	R/W	4	Acquire bandwidth mult. See ACQ_BW_SHIFT_DPLL1[4:0] description.
ACQ_DAMPING_SHIFT_DPLL1[2:0]	R/W	4	Acquire damping bandwidth shift The estimation for Gpeak is: $G_{peak}(dB) = 0.012 \times 2^{(ACQ_DAMPING_SHIFT_DPLL1-1)} \times ACQ_DAMPING_MULT_DPLL1/4$ --- assuming filter update rate is 562.5kHz. if update rate doubles, then Gpeak doubles
ACQ_DAMPING_MULT_DPLL1[2:0]	R/W	5	Acquire damping bandwidth mult. See ACQ_DAMPING_SHIFT_DPLL1[4:0] description.

DPLL-1 Phase Slope Limiting

Table 103. DPLL-1 Phase Slope Limiting Bit Field Locations

Address	D7	D6	D5	D4	D3	D2	D1	D0
0x01CC	PHASE_SLOPE_LIMIT_DPLL1[7:0]							
0x01CD	PHASE_SLOPE_LIMIT_DPLL1[15:8]							
0x01CE	PHASE_SLOPE_LIMIT_DPLL1[23:16]							
0x01CF	Reserved	PHASE_SLOPE_LIMIT_DPLL1[30:24]						
0x01D0	INTEGRATOR_LIMIT_DPLL1[7:0]							
0x01D1	INTEGRATOR_LIMIT_DPLL1[15:8]							
0x01D2	INTEGRATOR_LIMIT_DPLL1[23:16]							
0x01D3	Reserved	INTEGRATOR_LIMIT_DPLL1[30:24]						

Table 104. DPLL-1 Phase Slope Limiting Bit Field Descriptions

Bit Field Name	Field Type	Default Value	Description
PHASE_SLOPE_LIMIT_DPLL1[30:0]	R/W	0x7FFFFFFF	DPLL phase slope limit configuration. These bits are used to limit the phase slope of the DPLL output. 31-bit unsigned LSB = $2^{-37} \times 10^6$ (us/s)
INTEGRATOR_LIMIT_DPLL1[30:0]	R/W	0x7FFFFFFF	These bits are used to program the pull-in range of the DPLL. 31-bit, unsigned LSB = $2^{-43} \times 10^6$ (ppm) Max = $2^{31} \times 2^{-43} \times 10^6 = 244$ ppm

DPLL-1 Holdover, Phase Error Compensation (PEC)

Table 105. DPLL-1 Holdover, Phase Error Compensation Bit Field Locations and Descriptions

Address	D7	D6	D5	D4	D3	D2	D1	D0
0x01D4	HOLDOVER_BW_SHIFT_DPLL1[4:0]					HOLDOVER_MULT_DPLL1[2:0]		
0x01D5	HOLDOVER_MODE_DPLL1[1:0]		HOLDOVER_HISTORY_DPLL1[5:0]					
0x01D6	HOLDOVER_VALUE_DPLL1[7:0]							
0x01D7	HOLDOVER_VALUE_DPLL1[15:8]							
0x01D8	HOLDOVER_VALUE_DPLL1[23:16]							
0x01D9	HOLDOVER_VALUE_DPLL1[31:24]							
0x01DA	HOLDOVER_VALUE_DPLL1[39:32]							
0x01DB	Reserved						HOLDOVER_VALUE_DPLL1[41:40]	
0x01DC	PEC_CLK0_CORR_DPLL1[7:0]							
0x01DD	Reserved		PEC_CLK0_CORR_DPLL1[13:8]					
0x01DE	PEC_CLK1_CORR_DPLL1[7:0]							
0x01DF	Reserved		PEC_CLK1_CORR_DPLL1[13:0]					

Table 106. DPLL-1 Holdover, Phase Error Compensation Bit Field Locations and Descriptions

Bit Field a Name	Field Type	Default Value	Description
HOLDOVER_BW_SHIFT_DPLL1[4:0]	R/W	8	DPLL-1 Holdover filter bandwidth shift. Holdover filter bandwidth = $coe \times f / (2\pi)$ where $coe = 2^{-(33-HOLDOVER_BW_SHIFT_DPLL1)} \times HOLDOVER_MULT_DPLL1 / 4$ f = DPLL-1 update rate If coe = 0, the filter is bypassed.
HOLDOVER_MULT_DPLL1[2:0]	R/W	4	DPLL-1 Holdover filter bandwidth mult. See HOLDOVER_BW_SHIFT_DPLL1[4:0] description.
HOLDOVER_MODE_DPLL1[1:0]	R/W	0	00 = Instantaneous 01 = History instantaneous 10 = Manual holdover 11 = History averaged

Table 106. DPLL-1 Holdover, Phase Error Compensation Bit Field Locations and Descriptions (Cont.)

Bit Field a Name	Field Type	Default Value	Description
HOLDOVER_HISTORY_DPLL1[5:0]	R/W	0	Set holdover history from 1s to 64s 0 = Averaged value of 1s before 1 = Averaged value of 2s before ... 63= averaged value of 64s before
HOLDOVER_VALUE_DPLL1[41:0]	R/W	0	The value for manual holdover frequency. 42-bit, 2's complement LSB = 2^{-53} Max = ± 244 ppm
PEC_CLK0_CORR_DPLL1[13:0]	R/W	0x23	Phase error cancellation (PEC) to compensate the phase error from the 1st-order modulated fractional feedback divider. The residual part of the fractional feedback is scaled to TDC resolution and is compensated to the TDC phase error. PEC scale factor for using CLK_0 as input: $PEC_CORR = (T_{VCO} \div T_{DC_STEP}) \times 2^{DEN_BITS/DEN}$ where: <ul style="list-style-type: none"> ▪ T_{VCO}: period of the feedback divider input clock ▪ T_{DC_STEP}: TDC step size ▪ DEN_BITS: total number of bits of denominator bits (24 bits) ▪ DEN: denominator (M0_DEN_DPLL1[23:0])
PEC_CLK1_CORR_DPLL1[13:0]	R/W	0x23	Phase error cancellation (PEC) to compensate the phase error from the 1st-order modulated fractional feedback divider. The residual part of the fractional feedback is scaled to TDC resolution and is compensated to the TDC phase error. PEC scale factor for using CLK_1 as input: $PEC_CORR = (T_{VCO} \div T_{DC_STEP}) \times 2^{DEN_BITS/DEN}$ where: <ul style="list-style-type: none"> ▪ T_{VCO}: period of the feedback divider input clock ▪ T_{DC_STEP}: TDC step size ▪ DEN_BITS: total number of bits of denominator bits (24 bits) ▪ DEN: denominator (M1_DEN_DPLL1[23:0])

DPLL-1 Fractional Feedback Divider M1

Table 107. DPLL-1 Feedback Divider M1 Divider Bit Field Locations

Offset Address (Hex)	D7	D6	D5	D4	D3	D2	D1	D0
0x01E0	R0_DPLL1[7:0]							
0x01E1	Reserved						R0_DPLL1[9:8]	
0x01E2	R1_DPLL1[7:0]							
0x01E3	Reserved						R1_DPLL1[9:8]	
0x01E4	M1_INT_DPLL1[7:0]							
0x01E5	M1_INT_DPLL1[15:8]							
0x01E6	M1_INT_DPLL1[23:16]							
0x01E7	M1_INT_DPLL1[31:24]							
0x01E9	M1_NUM_DPLL1[7:0]							
0x01EA	M1_NUM_DPLL1[15:8]							
0x01EB	M1_NUM_DPLL1[23:16]							
0x01EC	M1_DEN_DPLL1[7:0]							
0x01ED	M1_DEN_DPLL1[15:8]							
0x01EE	M1_DEN_DPLL1[23:16]							

Table 108. DPLL-1 Feedback Divider M1 Divider Bit Field Descriptions

Bit Field Name	Field Type	Default Value	Description
R0_DPLL1[9:0]	R/W	0	CK0 pre-divider Pre-Divider is 14-bit and it can divide from 1 to $2^{10}-1$.
R1_DPLL1[9:0]	R/W	0	CK1 pre-divider Pre-Divider is 14-bit and it can divide from 1 to $2^{10}-1$.
M1_INT_DPLL1[31:0]	R/W	0xFBA	Integer portion of the fractional feedback divider of DPLL-1 for input clock 1 (REF1), (binary coding)
M1_NUM_DPLL1[23:0]	R/W	0x33F000	Integer portion of the fractional feedback divider of DPLL-1 for input clock 1 (REF1), (binary coding)
M1_DEN_DPLL1[23:0]	R/W	0x61A800	Integer portion of the fractional feedback divider of DPLL-1 for input clock 1 (REF1), (binary coding)

APLL-2 Configuration Registers

Table 109. APLL-2 Configuration Bit Field Locations

Address	D7	D6	D5	D4	D3	D2	D1	D0	
0x0200	M_INT_APLL2[7:0]								
0x0201	DSM_EN_APLL2	SYNTH_MODE	Reserved				Reserved		
0x0202	CAL_REF_APLL2[7:0]								
0x0203	CAL_EN_APLL2	Reserved	CAL_REF_APLL2[13:8]						
0x0204	M_NUM_APLL2[7:0]								
0x0205	M_NUM_APLL2[15:8]								
0x0206	M_NUM_APLL2[23:16]								
0x0208	M_DEN_APLL2[7:0]								
0x0209	M_DEN_APLL2[15:8]								
0x020A	M_DEN_APLL2[23:16]								
0x020C	Reserved	DSM_DITH_EN_APLL2	DSM_DITH_NS_APLL2	DSM_DITH_GAIN_APLL2[1:0]		DSM_ORDER_APLL2[1:0]		Reserved	
0x020D	EN_CP_APLL2	Reserved	ICP_OFFSET_APLL2[5:0]						
0x020E	GBOOST_APLL2[3:0]				EN_CPC_APLL2[3:0]				
0x020F	SOURCE_APLL2[3:0]				SINK_APLL2[3:0]				
0x0210	PD_APLL2	PD_PFD_APLL2	PD_M_APLL2	RSEL_APLL2	Reserved				

Table 110. APLL-2 Configuration Bit Field Locations

Bit Field Name	Field Type	Default Value	Description
M_INT_APLL2[7:0]	R/W	0x31	Integer portion of the APLL-2 PLL feedback divider.
SYNTH_MODE	R/W	1	APLL-2 Mode of operation 0 = APLL-2 is used as DCO for the SYS-DPLL 1 = APLL-2 is used as an independent synthesizer for output frequency generation. In this mode, SYS-DPLL operation is not possible
DSM_EN_APLL2	R/W	1	APLL-2 DSM (Delta-Sigma Modulator) enable. Determines the operational mode of the APLL-2 feedback divider. Must use fractional mode for use of APLL-2 as DCO of the SYS-DPLL. 0 = Integer mode (lower power, better spurious performance) $f_{VCO_APLL2} = f_{APLL2_IN} \times M_INT_APLL2$ Use for lowest spurious. 1 = Fractional mode: $f_{VCO_APLL2} = f_{APLL2_IN} \times [M_INT_APLL2 + (M_NUM_APLL2 \div M_DEN_APLL2)]$

Table 110. APLL-2 Configuration Bit Field Locations (Cont.)

Bit Field Name	Field Type	Default Value	Description
CAL_REF_APLL2[13:0]	R/W	0x675	APLL-2 VCO auto-calibration frequency reference divider $CAL_REF_APLL2[13:0] = 16384 \times f_{APLL2_REF} / (2 \times f_{VCO} \times 10\%)$ If APLL-2 is used as synthesizer, f_{APLL2_REF} is the frequency from either APLL-0 or APLL-1, if APLL-2 is used as part of the SYS-DPLL, f_{APLL2_REF} is the crystal frequency.
CAL_EN_APLL2	R/W	0 Value: Disabled	APLL-2 VCO auto-calibration enable. During VCO calibration, the PLL selects a VCO band. Leave this setting at the default value (auto-calibration is enabled). In auto-calibration, also configure CAL_REF_APLL2[13:0]. 0 = APLL-2 VCO auto-calibration is disabled (default). 1 = APLL-2 VCO auto-calibration is enabled
M_NUM_APLL2[23:0]	R/W	0x430000	APLL-2 Numerator (NUM) of the APLL-2 DSM. Value range is 0x000000 to 0xFFFFFFFF. $M_NUM_APLL2 < M_DEN_APLL2$; APLL-2 should be a large value (as close as possible to 0xFFFFFFFF). Set DSM_EN_APLL2 = 1 to use the APLL-2 in fractional mode. See the DSM_EN_APLL2 description for operation.
M_DEN_APLL2[23:0]	R/W	0x7D0000	APLL-2 Denominator (DEN) of the APLL-2 DSM. Value range is 0x000000 to 0xFFFFFFFF. Set $M_NUM_APLL2 < M_DEN_APLL2$. Set DSM_EN_APLL2 = 1 to use the APLL-2 in fractional mode. See the DSM_EN_APLL2 description for operation.
DSM_DITH_EN_APLL2	R/W	0	Dither enable for DSM of APLL-2. Value will be determined by Renesas. 0 = Dither off 1 = Dither on
DSM_DITH_NS_APLL2	R/W	0	Noise shaping for APLL-2 DSM. Value will be determined by Renesas. 0 = Dither not shaped 1 = Dither shaped
DSM_DITH_GAIN_APLL2[1:0]	R/W	00	Gain control for APLL-2 DSM. Value will be determined by Renesas. 00 = LSB 01 = $2 \times$ LSB 10 = $4 \times$ LSB 11 = $8 \times$ LSB
DSM_ORDER_APLL2[1:0]	R/W	11	Order for the APLL-2 DSM. Will be determined by Renesas. 00 = No accum 01 = First order 10 = Second order 11 = Third order
EN_CP_APLL2	R/W	1	APLL-2 enable charge pump 0 = Disable charge pump current 1 = Enable charge pump current

Table 110. APLL-2 Configuration Bit Field Locations (Cont.)

Bit Field Name	Field Type	Default Value	Description
EN_CPC_APLL2[3:0]	R/W	0xF	<p>The charge pump of APLL-2 contains of the parallel connection of identical 4 cores. When set to 1, each bit enables one charge pump core. Enabled charge pump cores are additive.</p> <p>0000 = no charge pump core enabled</p> <p>...</p> <p>1111 = 4 charge pump cores are enabled</p> <p>The APLL-2 charge pump current is programmable between 0μA and 2mA (source current) and in between 0μA to 500μA (sink current).</p> <p>APLL-2 source current (ICP_APLL-2):</p> $= 500\mu\text{A} \times (\text{EN_CPC_APLL2}[0] \times \text{SOURCE_APLL2}[0] + \text{EN_CPC_APLL2}[1] \times \text{SOURCE_APLL2}[1] + \text{EN_CPC_APLL2}[2] \times \text{SOURCE_APLL2}[2] + \text{EN_CPC_APLL2}[3] \times \text{SOURCE_APLL2}[3])$ <p>APLL-2 sink current (ICP_APLL-2):</p> $= 250\mu\text{A} \times (\text{EN_CPC_APLL2}[0] \times \text{SINK_APLL2}[0] + \text{EN_CPC_APLL2}[1] \times \text{SINK_APLL2}[1] + \text{EN_CPC_APLL2}[2] \times \text{SINK_APLL2}[2] + \text{EN_CPC_APLL2}[3] \times \text{SINK_APLL2}[3])$
SOURCE_APLL2[3:0]	R/W	1111	<p>APLL-2 individual charge pump source current enable.</p> <p>Each bit is defined as:</p> <p>0 = Charge pump n (n=0 to 3) source current disabled</p> <p>1 = Charge pump n (n=0 to 3) source current enabled</p>
SINK_APLL2[3:0]	R/W	0000	<p>APLL-2 individual charge pump sink current enable.</p> <p>Each bit is defined as:</p> <p>0 = Charge pump n (n=0 to 3) sink current disabled</p> <p>1 = Charge pump n (n=0 to 3) sink current enabled</p>
ICP_OFFSET_APLL2[5:0]	R/W	0x20	<p>APLL-2 programmable charge pump offset output current. ICP_OFFSET_APLL2 is an additive current applied to ICP_APLL2_PLL effectively introducing a phase offset into the APLL-2. Use ICP_OFFSET_APLL2 to improve charge pump linearity and APLL-2 phase noise.</p> <p>Offset current is programmable between 12.5μA and 487.5μA in 12.5μA steps.</p> $\text{ICP} = \text{ICP_OFFSET_APLL2}[0] \times 12.5\mu\text{A} + \text{ICP_OFFSET_APLL2}[1] \times 25\mu\text{A} + \text{ICP_OFFSET_APLL2}[2] \times 50.0\mu\text{A} + \text{ICP_OFFSET_APLL2}[3] \times 100\mu\text{A} + \text{ICP_OFFSET_APLL2}[4] \times 100\mu\text{A} + \text{ICP_OFFSET_APLL2}[5] \times 200\mu\text{A}$
GBOOST_APLL2[3:0]	R/W	1111	<p>APLL-2 Programmable reference voltage setting the voltage drops across the gain boosted cascode circuits. Value will be determined by Renesas.</p>
PD_APLL2	R/W	1 Value: Power down	<p>APLL-2 power down all APLL blocks except the VCO</p> <p>0 = Power up</p> <p>1 = Power down</p>
PD_PFD_APLL2	R/W	1 Value: Power down	<p>APLL-2 power down phase frequency detector</p> <p>0 = Power up</p> <p>1 = Power down</p>

Table 110. APLL-2 Configuration Bit Field Locations (Cont.)

Bit Field Name	Field Type	Default Value	Description
PD_ANA_APLL2	R/W	1 Value: Power down	APLL-2 power down feedback divider M_INT_APLL2 0 = Power up 1 = Power down
RSEL_APLL2	R/W	0 Value: Select APLL-0 as reference	RF-PLL Input reference select. 0 = APLL-0 is the reference for APLL-2 $f_{REF,RFPLL} = f_{APLL0} \div (2 \times P0)$ 1 = APLL-1 is the reference for the APLL-2 $f_{REF,RFPLL} = f_{APLL1} \div (2 \times P1)$

RF-PLL Configuration Registers

Table 111. RF-PLL Configuration Bit Field Locations

Address	D7	D6	D5	D4	D3	D2	D1	D0
0x0240	M_INT_RFPLL[7:0]							
0x0242	CAL_REF_RFPLL[7:0]							
0x0243	CAL_EN_RFPLL	Reserved	CAL_REF_RFPLL[13:8]					
0x0244	M_NUM_RFPLL[7:0]							
0x0245	M_NUM_RFPLL[15:8]							
0x0246	M_NUM_RFPLL[23:16]							
0x0248	M_DEN_RFPLL[7:0]							
0x0249	M_DEN_RFPLL[15:8]							
0x024A	M_DEN_RFPLL[23:16]							
0x024C	Reserved	DSM_DITH_EN_RFPLL	DSM_DITH_NS_RFPLL	DSM_DITH_G_RFPLL[1:0]		DSM_ORDER_RFPLL[1:0]		Reserved
0x024D	EN_CP_RFPLL	Reserved	ICP_OFFSET_RFPLL[5:0]					
0x024E	GBOOST_RFPLL[3:0]				EN_CPC_RFPLL[3:0]			
0x024F	SOURCE_RFPLL[3:0]				SINK_RFPLL[3:0]			
0x0250	PD_ALL_RFPLL	PD_PFD_RFPLL	PD_M_RFPLL	RSEL_RFPLL	FB_DIV_RFPLL[3:0]			

Table 112. RF-PLL Configuration Bit Field Descriptions

Bit Field Name	Field Type	Default Value	Description
M_INT_RFPLL[7:0]	R/W	0x0C	RF-PLL Integer Feedback (M) Divider.
CAL_REF_RFPLL[13:0]	R/W	0x1AAA	RF-PLL VCO auto-calibration frequency reference divider $CAL_REF_RFPLL[13:0] = 16384 \times f_{RFPLL_REF} / (2 \times f_{VCO} \times 10\%)$ f_{RFPLL_REF} is the frequency from either APLL-0 or APLL-1.

Table 112. RF-PLL Configuration Bit Field Descriptions (Cont.)

Bit Field Name	Field Type	Default Value	Description
CAL_EN_RFPLL	R/W	1 Value: Auto-Calibration	RF-PLL VCO auto-calibration enable. During VCO calibration, the PLL selects a VCO band. Leave this setting at the default value (auto-calibration is enabled). In auto-calibration, also configure CAL_REF_RFPLL[13:0]. 0 = RF-PLL VCO auto-calibration is disabled 1 = RF-PLL VCO auto-Calibration is enabled (default).
EN_CP_RFPLL	R/W	1	RF-PLL enable charge pump 0 = Disable charge pump current 1 = Enable charge pump current
EN_CPC_RFPLL[3:0]	R/W	1111	The charge pump of PLL-0 contains of the parallel connection of identical 4 cores. When set to 1, each bit enables one charge pump core. Enabled charge pump cores are additive. 0000 = No charge pump core enabled 1000 = First charge pump core enabled, other three cores disabled ... 1111 = 4 charge pump cores are enabled The RF_PLL charge pump current is programmable between 0μA and 2mA (source current) and in between 0μA to 500μA (sink current). RF_PLL source current (ICP_RF_PLL): = 500μA × (EN_CPC_RFPLL[0] × SOURCE_RFPLL[0] + EN_CPC_RFPLL[1] × SOURCE_RFPLL[1] + EN_CPC_RFPLL[2] × SOURCE_RFPLL[2] + EN_CPC_RFPLL[3] × SOURCE_RFPLL[3]) RF_PLL sink current (ICP_RF_PLL): = 250μA × (EN_CPC_RFPLL[0] × SINK_RFPLL[0] + EN_CPC_RFPLL[1] × SINK_RFPLL[1] + EN_CPC_RFPLL[2] × SINK_RFPLL[2] + EN_CPC_RFPLL[3] × SINK_RFPLL[3])
SOURCE_RFPLL[3:0]	R/W	1111	RF-PLL individual charge pump source current enable. Each bit is defined as: 0 = Charge pump core n (n=0 to 3) source current disabled 1 = Charge pump core n (n=0 to 3) source current enabled
SINK_RFPLL[3:0]	R/W	0000	RF-PLL individual charge pump sink current enable. Each bit is defined as: 0 = Charge pump n (n=0 to 3) sink current disabled 1 = Charge pump n (n=0 to 3) sink current enabled
ICP_OFFSET_RFPLL[5:0]	R/W	100000 Value: 200μA	RF-PLL programmable charge pump offset output current. ICP_OFFSET_RF_PLL is an additive current applied to ICP_RF_PLL effectively introducing a phase offset into the RF-PLL. Use ICP_OFFSET_RF_PLL to improve charge pump linearity and RF-PLL phase noise. Offset current is programmable between 12.5μA and 487.5μA in 12.5μA steps. ICP = ICP_OFFSET_RFPLL[0] × 12.5μA + ICP_OFFSET_RFPLL[1] × 25μA + ICP_OFFSET_RFPLL[2] × 50.0μA + ICP_OFFSET_RFPLL[3] × 100μA + ICP_OFFSET_RFPLL[4] × 100μA + ICP_OFFSET_RFPLL[5] × 200μA

Table 112. RF-PLL Configuration Bit Field Descriptions (Cont.)

Bit Field Name	Field Type	Default Value	Description
GBOOST_RFPLL[3:0]	R/W	1111	RF-PLL Programmable reference voltage setting the voltage drops across the gain boosted cascade circuits. Value will be determined by Renesas.
PD_ALL_RFPLL	R/W	0	RF-PLL power down all PLL blocks except VCO 0 = RF-PLL is powered up. 1 = RF-PLL is powered-down (VCO of RF-PLL is powered up)
PD_PFD_RFPLL	R/W	0	RF-PLL power down phase frequency detector 0 = Phase-frequency detector of RF-PLL is powered up. 1 = Phase-frequency detector of RF-PLL is powered down.
PD_M_RFPLL	R/W	0	Feedback divider M_RFPLL power-down 0 = RF-PLL feedback divider M_RFPLL is powered up. 1 = RF-PLL feedback divider M_RFPLL is powered down.
RSEL_RFPLL	R/W	1	RF-PLL Input reference select. 0 = APLL-0 is the reference for the RF-PLL $f_{REF,RFPLL} = f_{APLL0} \div (2 \times P0)$ 1 = APLL-1 is the reference for the RF-PLL $f_{REF,RFPLL} = f_{APLL1} \div (2 \times P1)$
FB_DIV_RFPLL[3:0]	R/W	6	Extended RF-PLL feedback divider $2^{(N+1)}$ (2 to 2048)

SYSREF Registers

Table 113. SYSREF Bit Field Locations

Address	D7	D6	D5	D4	D3	D2	D1	D0
0x288	Reserved	N_SYNC[6:0]						
0x289	PD_S	Reserved						SYSREF_AC
0x28A	N_S[3:0]			Reserved				
0x28B	SRPC[7:0]							
0x28C	ΦREF_S[7:0]							
0x28D	ΦREF_S[8]	Reserved						
0x28E	PD_SYSREF	Reserved		SRG[2:0]			SRO[1:0]	
0x28F	SRWC[7:0]							

Table 114. SYSREF Bit Field Descriptions

Bit Field Name	Field Type	Default Value	Description		
N_SYNC[6:0]	R/W	0011 010 Value: ÷24 (8 × 3)	<p>SYSREF Frequency and SYSREF Synchronizer divider.</p> <p>This divider controls the release of SYSREF pulses at coincident QCLK_y clock edges. For SYSREF operation, set this divider value to a common multiple of the output channel clock divider values N_x that is greater than or equal to 12. For instance, if N_R0=÷2, N_R1=÷3 and N_R2=÷4 set the N_SYNC divider to ÷12. N_SYNC is also a frequency divider for SYSREF, see N_S divider description.</p> <p>The value of the frequency divider is set by the product of N_SYNC[6:3] × N_SYNC[2:0]</p> <table border="0" style="width: 100%;"> <tr> <td style="width: 50%; vertical-align: top;"> <p>N_SYNC[6:3]</p> <p>0000 = ÷1 0001 = ÷2 0010 = ÷4 0011 = ÷8 0100 = ÷16 0101 = ÷32 0110 = ÷64 0111 = ÷128 1000 = ÷256 1001 = ÷512 1010 = ÷1024 1011 - 1111 = reserved</p> </td> <td style="width: 50%; vertical-align: top;"> <p>N_SYNC[2:0]</p> <p>000 = ÷1 001 = ÷2 010 = ÷3 011 = ÷4 100 = ÷5 101 - 111 = reserved</p> </td> </tr> </table>	<p>N_SYNC[6:3]</p> <p>0000 = ÷1 0001 = ÷2 0010 = ÷4 0011 = ÷8 0100 = ÷16 0101 = ÷32 0110 = ÷64 0111 = ÷128 1000 = ÷256 1001 = ÷512 1010 = ÷1024 1011 - 1111 = reserved</p>	<p>N_SYNC[2:0]</p> <p>000 = ÷1 001 = ÷2 010 = ÷3 011 = ÷4 100 = ÷5 101 - 111 = reserved</p>
<p>N_SYNC[6:3]</p> <p>0000 = ÷1 0001 = ÷2 0010 = ÷4 0011 = ÷8 0100 = ÷16 0101 = ÷32 0110 = ÷64 0111 = ÷128 1000 = ÷256 1001 = ÷512 1010 = ÷1024 1011 - 1111 = reserved</p>	<p>N_SYNC[2:0]</p> <p>000 = ÷1 001 = ÷2 010 = ÷3 011 = ÷4 100 = ÷5 101 - 111 = reserved</p>				
PD_S	R/W	0	<p>Power down SYSREF</p> <p>0 = All SYSREF functions are powered-up 1 = All SYSREF functions are powered-down</p>		
SYSREF_AC	R/W	0	<p>SYSREF output voltage bias</p> <p>0 = QREF_r outputs are in a low/high state when nBIAS_r is set to 1 or during a SYSREF event (use for DC coupled outputs) 1 = QREF_r outputs are in a cross-point biased state when nBIAS_r is set to 1 or during a SYSREF event (use for AC-coupled outputs).</p>		

Table 114. SYSREF Bit Field Descriptions (Cont.)

Bit Field Name	Field Type	Default Value	Description
N_S[3:0]	R/W	0110	N_S (together with N_SYNC) divides the RF-PLL frequency generating the SYSREF frequency for JESD204B operation. $f_{SYSREF} = f_{VCO_RF_PLL} \div (N_S \times N_SYNC)$ 0000 = ÷1 0001 = ÷2 0010 = ÷4 0011 = ÷8 0100 = ÷16 0101 = ÷32 0110 = ÷64 (default) 0111 = ÷128 1000 = ÷256 1001 = ÷512 1010 - 1111 = reserved.
SRPC[7:0]	R/W	1	SYSREF pulse count Binary value of the SYSREF pulses generated and output at all enabled QREF_r outputs. Allows to generate 1 to 255 pulses after each write access.
ΦREF_S[8:0]	R/W	0	ΦREF_S global SYSREF phase delay. This setting affects all QREF_r outputs. ΦREF_S[8:0] Delay in ps = ΦREF_S × 169ps (512 steps) 0 0000 0000 = 0ps ... 1 1111 1111 = 86.359ns
PD_SYSREF	R/W	0	SYSREF power down. Power-up for internal SYSREF generation and QREF_r output phase delay. Set to 1 (power down) when using EXT_SYSREF (external SYSREF trigger). 0 = Power up 1 = Power down
SRG[2:0]	R/W	100	SYSREF Generation mode (see Table 21) 000 = EXT_SYS input signal is buffered out to all SYSREF outputs 001 = EXT_SYS input signal is buffered out to all SYSREF outputs (synchronized) 010 = Externally triggered mode 011 = Internally triggered mode 100 = Continuous SYSREF mode

Table 114. SYSREF Bit Field Descriptions (Cont.)

Bit Field Name	Field Type	Default Value	Description	
SRO[1:0]	R/W	00	SYSREF pulse generation. See table Table 21 . SRO is defined for the SYSREF trigger modes SRG[2:0] = 010 and 011, otherwise SRO has no function.	
			SRG[2:0] = 010	00 = Pulsed, rising edge trigger 01 = Pulsed, falling edge trigger 10 = Rising edge starts pulses; falling edge stops pulses 11 = Falling edge starts pulses; rising edge stops pulses
			SRG[2:0] = 011	00 = Pulsed 01 = Reserved 10 = Reserved 11 = Pulsed with auto-repeat
SRWC[7:0]	R/W	0	SYSREF Pulse Wait Count: Binary value of the number of pulses the SYSREF generator waits before generating the next series of SYSREF pulses. Generates a pause of 1 to 255.	

Channel D0-D3 and R0-R3 Registers

Table 115. Channel D0-D3 and R0-R3 Configuration Bit Field Locations

Address	D7	D6	D5	D4	D3	D2	D1	D0
0x0290	Reserved	N_R0[6:0]						
0x0291	ΦCLK_R0[8:1]							
0x0292	PD_R0	Reserved						ΦCLK_R0[0]
0x0294	Reserved	N_R1[6:0]						
0x0295	ΦCLK_R1[8:1]							
0x0296	PD_R1	Reserved						ΦCLK_R1[0]
0x0298	Reserved	N_R2[6:0]						
0x0299	ΦCLK_R2[8:1]							
0x029A	PD_R2	Reserved						ΦCLK_R2[0]
0x029C	Reserved	N_R3[6:0]						
0x029D	ΦCLK_R3[8:1]							
0x029E	PD_R3	Reserved						ΦCLK_R3[0]
0x02A0	Reserved	N_D3[6:0]						
0x02A1	ΦCLK_D3[8:1]							
0x02A2	PD_D3	Reserved				D3_SRC[1:0]		ΦCLK_D3[0]
0x02A4	N_D2D3_EXT[7:0]							
0x02A5	N_D2D3_EXT[15:8]							
0x02A6	Reserved			N_D2D3_EXT[20:16]				
0x02A8	Reserved	N_D2[6:0]						
0x02A9	ΦCLK_D2[8:1]							
0x02AA	PD_D2	Reserved				D2_SRC[1:0]		ΦCLK_D2[0]
0x02B0	Reserved	N_D1[6:0]						
0x02B1	ΦCLK_D1[8:1]							
0x02B2	PD_D1	Reserved				D1_SRC[1:0]		ΦCLK_D1[0]
0x02B4	N_D0D1_EXT[7:0]							
0x02B5	N_D0D1_EXT[15:8]							
0x02B6	Reserved			N_D0D1_EXT[20:16]				
0x02B8	Reserved	N_D0[6:0]						
0x02B9	ΦCLK_D0[8:1]							
0x02BA	PD_D0	Reserved				D0_SRC[1:0]		ΦCLK_D0[0]
0x02C0	Reserved					SEL_SYNC_DPLL0		EN_PRE_SYNC_DPLL0
0x02C1	Reserved					SEL_SYNC_DPLL1		EN_PRE_SYNC_DPLL1

Table 115. Channel D0-D3 and R0-R3 Configuration Bit Field Locations (Cont.)

Address	D7	D6	D5	D4	D3	D2	D1	D0
0x02C2	Reserved			SEL_SYNC_APLL2				EN_PRE_SY NC_APLL2
0x02C3	Reserved	EN_QCLKD2 _TRIGGER	EN_COUNTE R_RFPLL	SEL_SYNC_RFPLL				EN_PRE_SY NC_RFPLL
0x02C4	RF_COUNT[7:0]							
0x02C5	RF_COUNT[15:8]							
0x02C6	Reserved			RF_COUNT[20:16]				

Table 116. Channel D0-D3 and R0-R3 Configuration Bit Field Descriptions

Bit Field Name	Field Type	Default Value	Description																							
N_x[6:0] (x=R0 to R3)	R/W	N_R0: 0001 010 Value: ÷6 N_R1: 0001 010 Value: ÷6 N_R2: 0001 010 Value: ÷6 N_R3: 0011 010 Value: ÷24	RF-PLL Output Channel Frequency Divider. The value of the frequency divider is set by the product of N_x[6:3] × N_x[2:0]. Always start using the largest possible N[2:0] divide to create a final divide.																							
			<table border="0"> <tr> <td style="text-align: center;">N_x[6:3]</td> <td style="text-align: center;">N_x[2:0]</td> </tr> <tr> <td>0000 = ÷1</td> <td>000 = ÷1</td> </tr> <tr> <td>0001 = ÷2</td> <td>001 = ÷2</td> </tr> <tr> <td>0010 = ÷4</td> <td>010 = ÷3</td> </tr> <tr> <td>0011 = ÷8</td> <td>011 = ÷4</td> </tr> <tr> <td>0100 = ÷16</td> <td>100 = ÷5</td> </tr> <tr> <td>0101 = ÷32</td> <td>101 = ÷9</td> </tr> <tr> <td>0110 = ÷64</td> <td>110 = ÷15</td> </tr> <tr> <td>0111 = ÷128</td> <td>111 = ÷25</td> </tr> <tr> <td>1000 = ÷256</td> <td></td> </tr> <tr> <td>1001 = ÷512</td> <td></td> </tr> <tr> <td>1010 = ÷1024</td> <td></td> </tr> <tr> <td>1011-1111 = Reserved</td> <td></td> </tr> </table>	N_x[6:3]	N_x[2:0]	0000 = ÷1	000 = ÷1	0001 = ÷2	001 = ÷2	0010 = ÷4	010 = ÷3	0011 = ÷8	011 = ÷4	0100 = ÷16	100 = ÷5	0101 = ÷32	101 = ÷9	0110 = ÷64	110 = ÷15	0111 = ÷128	111 = ÷25	1000 = ÷256		1001 = ÷512		1010 = ÷1024
N_x[6:3]	N_x[2:0]																									
0000 = ÷1	000 = ÷1																									
0001 = ÷2	001 = ÷2																									
0010 = ÷4	010 = ÷3																									
0011 = ÷8	011 = ÷4																									
0100 = ÷16	100 = ÷5																									
0101 = ÷32	101 = ÷9																									
0110 = ÷64	110 = ÷15																									
0111 = ÷128	111 = ÷25																									
1000 = ÷256																										
1001 = ÷512																										
1010 = ÷1024																										
1011-1111 = Reserved																										
ΦCLK_x[8:0] (x=R0 to R3)	R/W	0 0000 0100	RF-PLL Channel Phase Delay Delay in ps = ΦCLK_x × 169ps (512 steps) 0 0000 0000 = 0ps ... 1 1111 1111 = 86.359ns																							
PD_x (x=R0 to R3)	R/W	0	Power down RF-PLL clock channel x. This bit affects the dividers N_x and all output drivers in the channel. 0 = Power up 1 = Power down																							

Table 116. Channel D0-D3 and R0-R3 Configuration Bit Field Descriptions (Cont.)

Bit Field Name	Field Type	Default Value	Description																
N_d[6:0] (d=D0 to D3)	R/W	N_D0: 0001 111 Value: ÷50	N_d Digital Output Channel Frequency Divider. The value of the frequency divider is set by the product of N_d[6:3] × N_d[2:0]. Always start using the largest possible N_d[2:0] divide to create a final divide.																
		N_D1: 0010 100 Value: ÷20	<table border="1"> <tr> <td>N_d[6:3]</td> <td>N_d[2:0]</td> </tr> <tr> <td>0000 = ÷1</td> <td>000 = ÷1</td> </tr> <tr> <td>0001 = ÷2</td> <td>001 = ÷2</td> </tr> <tr> <td>0010 = ÷4</td> <td>010 = ÷3</td> </tr> <tr> <td>0011 = ÷8</td> <td>011 = ÷4</td> </tr> <tr> <td>0100 = ÷16</td> <td>100 = ÷5</td> </tr> <tr> <td>0101 = ÷32</td> <td>101 = ÷9</td> </tr> <tr> <td>0110 = ÷64 (will enable ext. divider)</td> <td>110 = ÷15</td> </tr> <tr> <td>0111 - 1111 = Reserved</td> <td>111 = ÷25</td> </tr> </table>	N_d[6:3]	N_d[2:0]	0000 = ÷1	000 = ÷1	0001 = ÷2	001 = ÷2	0010 = ÷4	010 = ÷3	0011 = ÷8	011 = ÷4	0100 = ÷16	100 = ÷5	0101 = ÷32	101 = ÷9	0110 = ÷64 (will enable ext. divider)	110 = ÷15
N_d[6:3]	N_d[2:0]																		
0000 = ÷1	000 = ÷1																		
0001 = ÷2	001 = ÷2																		
0010 = ÷4	010 = ÷3																		
0011 = ÷8	011 = ÷4																		
0100 = ÷16	100 = ÷5																		
0101 = ÷32	101 = ÷9																		
0110 = ÷64 (will enable ext. divider)	110 = ÷15																		
0111 - 1111 = Reserved	111 = ÷25																		
		N_D2: 0001 011 Value: ÷8	See N_D1D0_EXT[20:0] and N_D3D2_EXT[20:0] which extends the N_d dividers to divide down to frequencies such as 1Hz (1PPS).																
		N_D3: 0000 111 Value: ÷25																	
ΦCLK_d[8:0] (d=D0 to D3)	R/W	QCLK_D0: 0 0000 0000	Output Phase Delay Delay in ps = ΦCLK_d × (0.5÷f _{VCO}) ps (512 steps). The delay unit is the half-period of the VCO of the selected frequency source. Frequency sources are DPLL-0/APLL-0, APLL-2 and the RF-PLL, selected by D0_SRC[1:0], D1_SRC[1:0], D2_SRC[1:0], and D3_SRC[1:0].																
		QCLK_D1: 0 0000 1010	0 0000 0000 = 0 ps																
		QCLK_D2: 0 0000 1010	...																
		QCLK_D3: 0 0000 0000	1 1111 1111 = 511 × (0.5÷f _{VCO_SELECTED})																
PD_d (d=D0 to D3)	R/W	0	Power down outputs Dd. This bit affects the dividers N_d and all output drivers in the channel. 0 = Power up 1 = Power down																
D0_SRC[1:0], D1_SRC[1:0]	R/W R/W	00 00	Output source selector (applies to outputs D0 and D1, respectively) 00 = DPLL-0 (DCO-0)/APLL-0 01 = APLL-2 10 = Reserved 11 = Reserved																
D2_SRC[1:0], D3_SRC[1:0]	R/W R/W	00 00	Output source selector (applies to outputs D2 and D3, respectively) 00 = DPLL-0 (DCO-0)/APLL-0 01 = APLL-2 10 = RF-PLL 11 = Reserved																

Table 116. Channel D0-D3 and R0-R3 Configuration Bit Field Descriptions (Cont.)

Bit Field Name	Field Type	Default Value	Description	
N_D1D0_EXT[20:0]	R/W	0x0000 Value: ÷1	<p>Extended output divider for N_D1, N_D0. Use this divider together with N_D0, N_D1 to achieve higher divider values for N_D0, N_D1, for instance for dividing down to 1Hz (1PPS).</p> <p>Extends the N_D0 output divider if N_D0[6:3] = 0110 and extends the N_D1 output divider if N_D1[6:3] = 0110. This divider can be used to extend N_D0 or N_D1 or both.</p> <p>Divider has no effect if neither N_D0[6:3] nor N_D1[6:3] are set to 0110.</p>	
			N_D1[6:3], N_D0[6:3] = 0110	N_D1[6:3], N_D0[6:3] ≠ 0110
			<p>N_D1D0_EXT is a binary-coded frequency divider that extends the divide value of N_D1, ND_0.</p> <p>Effective N_D1, ND_0 divider is:</p> <ul style="list-style-type: none"> ▪ for N_D1: N_D1[6:3] × N_D1[2:0] × N_D1D0_EXT[20:0]. ▪ for N_D0: N_D0[6:3] × N_D0[2:0] × N_D1D0_EXT[20:0]. <p>N_D1D0_EXT[20:0] coding:</p> <p>0 0000 0000 0000 0000 0000 = ÷1 0 0000 0000 0000 0000 0001 = ÷2 0 0000 0000 0000 0000 0010 = ÷4 0 0000 0000 0000 0000 0011 = ÷6 0 0000 0000 0000 0000 0100 = ÷8 ... 1 1111 1111 1111 1111 1111 = ÷4,194,302</p> <p>Example extending ND_0: N_D0[6:3] = 0110 (÷64) N_D0[2:0] = 111 (÷25) N_D1D0_EXT[20:0] = ÷1,562,500</p> <p>The total N_D0 divider is ÷2,500,000,000. With a given DPLL-0/APLL-0 frequency of 2450-2580MHz the QCLK_D0 output frequency is 1Hz (1PPS): 2450-2580MHz ÷ (64 × 25 × 1,562,500)</p>	N_D1, N_D0 dividers values are not extended

Table 116. Channel D0-D3 and R0-R3 Configuration Bit Field Descriptions (Cont.)

Bit Field Name	Field Type	Default Value	Description	
N_D2D3_EXT[20:0]	R/W	0	<p>Extended output divider for N_D2, N_D3. Use this divider together with N_D2, N_D3 to achieve higher divider values for N_D2, N_D3, for instance for dividing down to 1Hz (1PPS).</p> <p>Extends the N_D2 output divider if N_D2[6:3] = 0110 and extends the N_D3 output divider if N_D3[6:3] = 0110. This divider can be used to extend N_D2 or N_D3 or both.</p> <p>Divider has no effect if neither N_D2[6:3] nor N_D3[6:3] are set to 0110.</p>	
			N_D2[6:3], N_D3[6:3] = 0110	N_D2[6:3], N_D3[6:3] ≠ 0110
			<p>N_D2D3_EXT is a binary-coded frequency divider that extends the divide value of N_D2, ND_3.</p> <p>Effective N_D2, N_D3 divider is:</p> <ul style="list-style-type: none"> ▪ for N_D2: N_D2[6:3] × N_D2[2:0] × N_D2D3_EXT[20:0]. ▪ for N_D3: N_D3[6:3] × N_D3[2:0] × N_D2D3_EXT[20:0]. <p>N_D2D3_EXT[20:0] coding:</p> <p>0 0000 0000 0000 0000 0000 = ÷1</p> <p>0 0000 0000 0000 0000 0001 = ÷2</p> <p>0 0000 0000 0000 0000 0010 = ÷4</p> <p>0 0000 0000 0000 0000 0011 = ÷6</p> <p>0 0000 0000 0000 0000 0100 = ÷8</p> <p>...</p> <p>1 1111 1111 1111 1111 1111 = ÷4,194,302</p> <p>Example extending ND_2:</p> <p>N_D2[6:3] = 0110 (÷64)</p> <p>N_D2[2:0] = 111 (÷25)</p> <p>N_D2D3_EXT[20:0] = ÷1,562,500</p> <p>The total N_D2 divider is ÷2,500,000,000. With a given DPLL-0/APLL-0 frequency of 2450-2580MHz the QCLK_D2 output frequency is 1Hz (1PPS):</p> $2450\text{-}2580\text{MHz} \div (64 \times 25 \times 1,562,500)$	N_D2, N_D3 divider values are not extended

Table 116. Channel D0-D3 and R0-R3 Configuration Bit Field Descriptions (Cont.)

Bit Field Name	Field Type	Default Value	Description
SEL_SYNC_DPLLn[1:0] n = 0, 1	R/W	01	<p>Synchronization signal selector of DPLL-0/1. Selects the DPLL-0/1 synchronization signal as part of an input-to-output alignment procedure (for information, see Input to Output Phase Alignment). The SEL_SYNC_DPLLn selector bits must be configured before the bit INIT_CLK_A (DPLL-0 divider reset) and INIT_CLK_B (DPLL-1 divider reset) is set for reset/synchronization.</p> <p>00 = Reserved 01 = Selects the internal INIT3 signal as synchronization signal. Use for phase-alignment of non-1PPS input clocks to the outputs. 10 = Select the DPLL-0/1 output feedback divider M as synchronization signal. Use for phase-alignment of 1PPS input clocks to the outputs. 11 = Reserved</p> <p>Use the setting 10 (selects output of DPLLn feedback divider) when locking to 1PPS input signals, otherwise, use the setting 01.</p>
EN_PRESYNC_DPLLn n = 0,1		0	<p>Selects the VCO clock used for synchronization of DPLL-0/1 as the feedback clock for the feedback divider of DPLL-0/1 (for information, see Input to Output Phase Alignment). The EN_PRESYNC_DPLLn bits must be configured before the bit INIT_CLK_A (DPLL-0 divider reset) and INIT_CLK_B (DPLL-1 divider reset) is set for reset/synchronization.</p> <p>0 = Select the VCO clock of DPLL(APLL)-0/1 before synchronization. This is the preferred setting for locking DPLL-0/1 to a non-1PPS input signal 1 = Select the VCO clock of DPLL(APLL)-0/1 after synchronization. This is the preferred setting for locking DPLL-0/1 to a 1PPS input signal.</p>
SEL_SYNC_APLL2[3:0]	R/W	0001	<p>Synchronization signal selector of APLL-2. Selects the APLL-2 synchronization signal as part of an input-to-output alignment procedure (for information, see Input to Output Phase Alignment). The SEL_SYNC_APLL2 selector bit must be configured before the bit INIT_CLK_C (APLL-2 divider reset) is set for reset/synchronization.</p> <p>0000 = Reserved 0001 = Selects the internal INIT3 signal as the synchronization signal of APLL-2 0010 = Select the DPLL-0 feedback divider M output as the synchronization signal of APLL-2. Use for phase-alignment of 1PPS input clocks (through DPLL-0) to the outputs. 0100 = Select the QCLK_D2 output as the synchronization signal of APLL-2 1000 = Select the DPLL-1 feedback divider M as the synchronization signal of APLL-2. Use for phase-alignment of 1PPS input clocks (through DPLL-1) to the outputs.</p> <p>All other bit combinations are reserved</p>
EN_PRESYNC_APLL2		0	<p>Selects the VCO clock used for synchronization of APLL-2 as the feedback clock for the feedback divider of APLL-2 (for information, see Input to Output Phase Alignment). The EN_PRESYNC_APLL2 bit must be configured before the bit INIT_CLK_C (APLL-2 divider reset) is set for reset/synchronization.</p> <p>0 = Select the VCO clock of APLL-2 before synchronization. This is the preferred setting for locking to a non-1PPS input signal (through DPLL-0 or through DPLL-1) 1 = Select the VCO clock of APLL-2 after synchronization. This is the preferred setting for locking DPLL-0/1 to a 1PPS input signal (through DPLL-0 or through DPLL-1)</p>

Table 116. Channel D0-D3 and R0-R3 Configuration Bit Field Descriptions (Cont.)

Bit Field Name	Field Type	Default Value	Description
SEL_SYNC_RFPLL[3:0]	R/W	0001	<p>Synchronization signal selector of RF-PLL. Selects the RF-PLL synchronization signal as part of an input-to-output alignment procedure (for information, see Input to Output Phase Alignment). The SEL_SYNC_RF{LL} selector bit must be configured before the bit INIT_CLK_D (RF-PLL divider reset) is set for reset/synchronization.</p> <p>0000 = Reserved 0001 = Selects the internal INIT3 signal as the synchronization signal of RF-PLL 0010 = Select the DPLL-0 feedback divider M output as the synchronization signal of RF-PLL. Use for phase-alignment of 1PPS input clocks (through DPLL-0) to the outputs. 0100 = Select the QCLK_D2 output as the synchronization signal of RF-PLL 1000 = Select the DPLL-1 feedback divider M as the synchronization signal of RF-PLL. Use for phase-alignment of 1PPS input clocks (through DPLL-1) to the outputs. All other bit combinations are reserved</p>
EN_PRESYNC_RFPLL		0	<p>Selects the VCO clock used for synchronization of RF-PLL as the feedback clock for the feedback divider of RF_PLL (for information, see Input to Output Phase Alignment). The EN_PRESYNC_RFPLL bit must be configured before the bit INIT_CLK_D (RF-PLL divider reset) is set for reset/synchronization.</p> <p>0 = Select the VCO clock of RF-PLL before synchronization. This is the preferred setting for locking to a non-1PPS input signal (through DPLL-1) 1 = Select the VCO clock of RF-PLL after synchronization. This is the preferred setting for locking DPLL-0/1 to a 1PPS input signal (through DPLL-1)</p>
EN_QCLKD2_TRIGGER	R/W	0	<p>Selects operation of RFPLL QCLKD2</p> <p>0 = RFPLL QCLKD2 CLK is always low 1 = RFPLL QCLKD2 CLK is active</p>
EN_COUNTER_RFPLL	R/W	0	<p>Selects RFPLL SYNC</p> <p>0 = RFPLL SYNC is released from DPLL1 FB divider 1 = RFPLL SYNC is released upon completion of RF_COUNT</p>
RF_COUNT[20:0]		0x100000	RF-PLL synchronization counter. Sets Count values to 2 ^N value (1 to 2,097,151).

Output Registers

Table 117. Output Register Bit Field Locations

Address	D7	D6	D5	D4	D3	D2	D1	D0
QCLK_R0 to QCLK_R5								
0x02D0	QCLK_R0_PD	Reserved			QCLK_R0_V VOS	QCLK_R0_STYLE	QCLK_R0_A[1:0]	
0x02D2	QCLK_R1_PD	Reserved			QCLK_R1_V VOS	QCLK_R1_STYLE	QCLK_R1_A[1:0]	
0x02D4	QCLK_R2_PD	Reserved			QCLK_R2_V VOS	QCLK_R2_STYLE	QCLK_R2_A[1:0]	
0x02D6	QCLK_R3_PD	Reserved			QCLK_R3_V VOS	QCLK_R3_STYLE	QCLK_R3_A[1:0]	
0x02DA	QCLK_R4_PD	Reserved			QCLK_R4_V VOS	QCLK_R4_STYLE	QCLK_R4_A[1:0]	
0x02DE	QCLK_R5_PD	Reserved			QCLK_R5_V VOS	QCLK_R5_STYLE	QCLK_R5_A[1:0]	
QCLK_D3 to QCLK_D0								
0x02E0	QCLK_D3_PD	Reserved			QCLK_D3_V VOS	QCLK_D3_STYLE	QCLK_D3_A[1:0]	
0x02E1	QCLK_D3_CMOS_SEL		QCLK_D3_POL		Reserved	QCLK_D3_DS	QCLK_D3_SR	
0x02E2	QCLK_D2_PD	Reserved			QCLK_D2_V VOS	QCLK_D2_STYLE	QCLK_D2_A[1:0]	
0x02E3	QCLK_D2_CMOS_SEL		QCLK_D2_POL		Reserved	QCLK_D2_DS	QCLK_D2_SR	
0x02E4	QCLK_D1_PD	Reserved			QCLK_D1_V VOS	QCLK_D1_STYLE	QCLK_D1_A[1:0]	
0x02E5	QCLK_D1_CMOS_SEL		QCLK_D1_POL		Reserved	QCLK_D1_DS	QCLK_D1_SR	
0x02E6	QCLK_D0_PD	Reserved			QCLK_D0_V VOS	QCLK_D0_STYLE	QCLK_D0_A[1:0]	
0x02E7	QCLK_D0_CMOS_SEL		QCLK_D0_POL		Reserved	QCLK_D0_DS	QCLK_D0_SR	
QREF_R0 to QREF_R5								
0x02E8	QREF_R5_PD	Reserved			QREF_R5_V VOS	QREF_R5_STYLE	QREF_R5_A[1:0]	
0x02E9	Reserved				Φ REF_R5[3:0]			
0x02EA	QREF_R4_PD	Reserved			QREF_R4_V VOS	QREF_R4_STYLE	QREF_R4_A[1:0]	
0x02EB	Reserved				Φ REF_R4[3:0]			
0x02EC	QREF_R3_PD	Reserved			QREF_R3_V VOS	QREF_R3_STYLE	QREF_R3_A[1:0]	

Table 117. Output Register Bit Field Locations (Cont.)

Address	D7	D6	D5	D4	D3	D2	D1	D0
0x02ED	Reserved				ΦREF_R ₂ [3:0]			
0x02EE	QREF_R2_PD	Reserved			QREF_R2_VOS	QREF_R2_STYLE	QREF_R2_A[1:0]	
0x02EF	Reserved				ΦREF_R ₁ [3:0]			
0x02F0	QREF_R1_PD	Reserved			QREF_R1_VOS	QREF_R1_STYLE	QREF_R1_A[1:0]	
0x02F1	Reserved				ΦREF_R ₀ [3:0]			
0x02F2	QREF_R0_PD	Reserved			QREF_R0_VOS	QREF_R0_STYLE	QREF_R0_A[1:0]	
0x02F3	Reserved				ΦREF_R ₀ [3:0]			

Table 118. Output Register Bit Field Descriptions

Bit Field Name	Field Type	Default Value	Description
QCLK_y_PD	R/W	0	Output QCLK_y Power Down 0 = Output powered up 1 = Output powered down
QCLK_y_VOS	R/W	0	Output QCLK_y crosspoint voltage (VOS). Only applicable to LVDS (QCLK_y_STYLE = 1). See Table 138 for VOS values. 0 = Output VOS is related to V_{DD0_V} 1 = Output VOS is 1.25V (typical). Requires $V_{DD0_V} = 3.3V$ QCLK_R4, R5 VOS controls also VOS of the QCLK_R4b, QCLK_R5b outputs, respectively, when R4b, R5b are powered-on and bonded out.
QCLK_y_STYLE	R/W	1	Output QCLK_y Style 0 = Output is LVPECL 1 = Output is LVDS QCLK_R4, R5 STYLE controls also STYLE of the QCLK_R4b, QCLK_R5b outputs, respectively, when R4b, R5b are powered-on and bonded out.
QCLK_y_A[1:0]	R/W	11	Output QCLK_y Amplitude QCLK_R4, R5_A controls also Amplitude of the QCLK_R4b, QCLK_R5b outputs, respectively, when R4b, R5b are powered-on and bonded out. QCLK_y_STYLE = 0 (LVPECL) QCLK_y_STYLE = 1 (LVDS)
			00 = 350mV 01 = 500mV 10 = 750mV 11 = 1000mV
QCLK_d_PD	R/W	0	Output QCLK_d Power Down 0 = Output powered up 1 = Output powered down

Table 118. Output Register Bit Field Descriptions (Cont.)

Bit Field Name	Field Type	Default Value	Description
QCLK_d_VOS	R/W	1	Output QCLK_d crosspoint voltage (VOS). Only applicable to LVDS (QCLK_d_STYLE = 1). See Table 138 for VOS values. 0 = Output VOS is related to V_{DDO_V} 1 = Output VOS is 1.25V (typical). Requires $V_{DDO_V} = 3.3V$
QCLK_d_STYLE	R/W	1	Output QCLK_d differential output style. The output is differential LVPECL or LVDS if QCLK_d_CMOS_SEL[1:0] = 00 0 = Output is LVPECL 1 = Output is LVDS
QCLK_d_A[1:0]	R/W	11	Output QCLK_Dy Amplitude. Applies to differential LVPECL, LVDS. Does not apply if output is set to LVCMOS QCLK_d_STYLE = 0 (LVPECL) QCLK_d_STYLE = 1 (LVDS)
			00 = 350mV 01 = 500mV 10 = 750mV 11 = 1000mV
QCLK_d_CMOS_SEL	R/W	QCLK_D0: 11 QCLK_D1: 00 QCLK_D2: 00 QCLK_D3: 00	LVC MOS Select for the QCLK_d and nQCLK_d outputs 00 = QCLK_d is differential as set by the QCLK_d_STYLE bit 01 = QCLK_d is LVCMOS (active), nQCLK_d is in high impedance state 10 = QCLK_d is in high impedance state, nQCLK_d is LVCMOS (active) 11 = QCLK_d and nQCLK_d are both set to LVCMOS (active)
QCLK_d_POL	R/W	QCLK_D0: 10 QCLK_D1: 00 QCLK_D2: 00 QCLK_D3: 00	Output Polarity Select for non-inverting (QCLK_Dn) outputs configured to LVCMOS 00 = QCLK_d and nQCLK_d are both inverted 01 = QCLK_d polarity is inverted, nQCLK_d is normal 10 = QCLK_d polarity is normal, nQCLK_d is inverted 11 = QCLK_d, QCLK_Dn QCLK_d both have normal polarity
QCLK_d_DS	R/W	QCLK_D0: 0 QCLK_D1: 0 QCLK_D2: 0 QCLK_D3: 0	LVC MOS QCLK_Dn, nQCLK_Dn Output Drive Strength 0 = Regular (~18Ω at $V_{DDO_V} = 3.3V$, 30Ω at $V_{DDO_V} = 1.8V$) 1 = High (~9Ω at $V_{DDO_V} = 3.3V$, 15Ω at $V_{DDO_V} = 1.8V$)
QCLK_d_SR[1:0]	R/W	QCLK_D0: 00 QCLK_D1: 00 QCLK_D2: 00 QCLK_D3: 11	LVC MOS QCLK_Dn, nQCLK_Dn Output Slew Rate If QCLK_d_DS = 0 (Regular drive strength setting) x0 = Normal output slew rate for QCLK_d, nQCLK_d x1 = Reduced output slew rate for QCLK_d, nQCLK_d If QCLK_d_DS = 1 (High drive strength setting) 00 = Normal output slew rate for QCLK_d, nQCLK_d 01 = Reduced slew rate for QCLK_d, nQCLK_d 10 = Reduced slew rate for QCLK_d, nQCLK_d 11 = Low slew rate for QCLK_d, nQCLK_d
QREF_r_PD	R/W	1	Output QREF_r Power Down 0 = Output powered up 1 = Output powered down (high-impedance)

Table 118. Output Register Bit Field Descriptions (Cont.)

Bit Field Name	Field Type	Default Value	Description
QREF_r_VOS	R/W	1	Output QREF_r crosspoint voltage (VOS). Only applicable to LVDS (QREF_r_STYLE = 1). See Table 138 for VOS values. 0 = Output VOS is related to V_{DDO_V} 1 = Output VOS is 1.25V (typical). Requires $V_{DDO_V} = 3.3V$
QREF_r_STYLE	R/W	1	Output QREF_r Style 0 = Output is LVPECL 1 = Output is LVDS
QREF_r_A[1:0]	R/W	10	Output QREF_r Amplitude. QREF_r_STYLE = 0 (LVPECL) QREF_r_STYLE = 1 (LVDS)
			00 = 350mV 01 = 500mV 10 = 750mV 11 = 1000mV
Φ REF_Rr[3:0]	R/W	1000	SYSREF Output Rr Fine Phase Delay The delay is composed of 7 digital delay steps (half-period of the RF-PLL, 169ps) coded in bits [3:1] and an analog delay step coded in bit [0]. The analog delay step may vary from 60ps and 90ps over PVT. Delay in ps = Φ REF_Rr[3:1] \times 169ps + Φ REF_Rr[0] \times 75ps 0000 = 0ps 0001 = 75ps 0010 = 169ps 0011 = 169ps + 75ps = 244ps 0100 = 339ps 0101 = 339ps + 75ps = 414ps ... 1110 = 1186ps 1111 = 1186ps + 75ps = 1,261ps

GPIO Registers

Table 119. GPIO Register Bit Field Locations

Address	D7	D6	D5	D4	D3	D2	D1	D0
0x0300	Reserved			GPIO_0_TYPE	GPIO_0_FUNC[3:0]			
0x0301	Reserved			GPIO_1_TYPE	GPIO_1_FUNC[3:0]			
0x0302	Reserved			GPIO_2_TYPE	GPIO_2_FUNC[3:0]			
0x0303	Reserved			GPIO_3_TYPE	GPIO_3_FUNC[3:0]			

Table 120. GPIO Register Bit Field Descriptions

Bit Field Name	Field Type	Default Value	Description
GPIO_n_TYPE n = 0 to 3	R/W	GPIO_0: 0 GPIO_1: 0 GPIO_2: 1 GPIO_3: 1	Type of the GPIO pin 0 = GPIO pin is input 1 = GPIO pin is output GPIO_0: pin 19 GPIO_1: pin 20 GPIO_2: pin 21 GPIO_3: pin 22 GPIO_n_TYPE can be changed at any time after the device completed its startup, indicated by READY at the GPIO_3 pin and the register bit DEVICE_RDY_STS . GPIO_n_TYPE is not copied into the device in an EEPROM load operation.
GPIO_0_FUNC	R/W	0110	Function of the GPIO_0 pin. See also Table 26 for details and the definition of the output groups 0-6. 0000 = Interrupt 0001 = Input0 valid status 0010 = Debug: DPLL-1 feedback clock 0011 = DPLL-1 lock status 0100 = APLL-0 lock status 0101 = APLL-1 lock status 0110 = DPLL-0 input selection 0111 = CLK_0 disqualify 1000 = CLK_1 disqualify 1001 = Output group 0 enable 1010 = Output group 1 enable 1011 = Output group 2 enable 1100 = Output group 3 enable 1101 = Output group 4 enable 1110 = Output group 5 enable 1111 = Output group 6 enable GPIO_0_FUNC can be changed at any time after the device completed its startup, indicated by READY at the GPIO_3 pin and the register bit DEVICE_RDY_STS . GPIO_0_FUNC is not copied into the device in an EEPROM load operation.

Table 120. GPIO Register Bit Field Descriptions (Cont.)

Bit Field Name	Field Type	Default Value	Description
GPIO_1_FUNC	R/W	0110	<p>Function of the GPIO_1 pin. See also Table 27 for details and the definition of the output groups 0-6.</p> <p>0000 = Interrupt 0001 = Input1 valid status 0010 = Debug: SYS-APLL feedback clock 0011 = DPLL-1 lock status 0100 = APLL-1 lock status 0101 = RF-PLL lock status 0110 = DPLL-1 input selection 0111 = CLK_0 disqualify 1000 = CLK_1 disqualify 1001 = Output group 0 enable 1010 = Output group 1 enable 1011 = Output group 2 enable 1100 = Output group 3 enable 1101 = Output group 4 enable 1110 = Output group 5 enable 1111 = Output group 6 enable</p> <p>GPIO_1_FUNC can be changed at any time after the device completed its startup, indicated by READY at the GPIO_3 pin and the register bit DEVICE_RDY_STS. GPIO_1_FUNC is not copied into the device in an EEPROM load operation.</p>

Table 120. GPIO Register Bit Field Descriptions (Cont.)

Bit Field Name	Field Type	Default Value	Description
GPIO_2_FUNC	R/W	1010	<p>Function of the GPIO_2 pin. See also Table 28 for details and the definition of the output groups 0-6.</p> <p>0000 = Interrupt 0001 = CLK_0 valid status 0010 = DPLL-0 holdover status 0011 = DPLL-1 holdover status 0100 = DPLL-0 lock status 0101 = DPLL-1 lock status 0110 = APLL-0 lock status 0111 = RF-PLL lock status 1000 = DPLL-0 input selection 1001 = Output group 0 enable 1010 = Output group 1 enable 1011 = Output group 2 enable 1100 = Output group 3 enable 1101 = Output group 4 enable 1110 = Output group 5 enable 1111 = Output group 6 enable</p> <p>GPIO_2_FUNC can be changed at any time after the device completed its startup, indicated by READY at the GPIO_3 pin and the register bit DEVICE_RDY_STS. GPIO_2_FUNC is not copied into the device in an EEPROM load operation.</p>
GPIO_3_FUNC	R/W	0011	<p>Function of the GPIO_3 pin. See also Table 29 for details and the definition of the output groups 0-6.</p> <p>0000 = Interrupt 0001 = CLK_0 valid status 0010 = CLK_1 valid status 0011 = Device ready status 0100 = DPLL-0 lock status 0101 = DPLL-1 lock status 0110 = APLL-0 lock status 0111 = APLL-2 lock status 1000 = DPLL-1 input selection 1001 = Output group 0 enable 1010 = Output group 1 enable 1011 = Output group 2 enable 1100 = Output group 3 enable 1101 = Output group 4 enable 1110 = Output group 5 enable 1111 = Output group 6 enable</p> <p>GPIO_3_FUNC can be changed at any time after the device completed its startup, indicated by READY at the GPIO_3 pin and the register bit DEVICE_RDY_STS. GPIO_3_FUNC is not copied into the device in an EEPROM load operation.</p>

Device Status

Address	D7	D6	D5	D4	D3	D2	D1	D0
0x0317	ST_CAL_FIN_ALL	ST_I2C_MASTER_CLK_EN	ST_INITREF	Reserved	Reserved	Reserved	Reserved	ST_INITCLK

Bit Field Name	Field Type	Default Value	Description
ST_CAL_FIN_ALL	R/O	0	PLL calibration status 0 = APLL calibration not completed 1 = All APLLs have completed calibration (VCO band selection)
ST_I2C_MASTER_CLK_EN	R/O	0	Master clock activation status 0 = Not active. 1 = Active.
ST_INIT_REF			INIT_REF Synchronization Status. Indicates if QREF_r outputs are active and synchronized to QCLK_y outputs. 0 = Not synchronized or no active SYSREF event 1 = One or more QREF_r outputs are active and synchronized to the QCLK_y outputs.
ST_INITCLK	R/O		Internal initialization sequence status 0 = INIT_CLK_x initialization sequence is completed 1 = INIT_CLK_x initialization sequence active or stuck x = A, B, C, D

DPLL-0/DPLL-1/APLL-2/RF-PLL Status

Table 121. DPLL-0/DPLL-1/APLL-2/RF-PLL Field Locations

Address	D7	D6	D5	D4	D3	D2	D1	D0
0x0318	ST_DBIT_APLL0[7:0]							
0x0319	Reserved				ST_LOCK_A PLL0	ST_CAL_OV_ APLL0	ST_CAL_FIN_ _APLL0	ST_DBIT_AP LL0[8]
0x031A	ST_DBIT_APLL1[7:0]							
0x031B	Reserved				ST_LOCK_A PLL1	ST_CAL_OV_ APLL1	ST_CAL_FIN_ _APLL1	ST_DBIT_AP LL1[8]
0x031C	ST_DBIT_APLL2[7:0]							
0x031D	Reserved				ST_LOCK_A PLL2	ST_CAL_OV_ APLL2	ST_CAL_FIN_ _APLL2	ST_DBIT_AP LL2[8]
0x031E	ST_DBIT_RFPLL[7:0]							
0x031F	Reserved				ST_LOCK_R FPLL	ST_CAL_OV_ RFPLL	ST_CAL_FIN_ _RFPLL	ST_DBIT_RF PLL[8]

Table 122. DPLL-0/DPLL-1/APLL-2/RF-PLL Field Locations

Bit Field Name	Field Type	Default Value	Description
ST_DBIT_p[8:0] p = APLL0, APLL1, APLL2, RFPLL	R/O	0	Frequency band selected by PLL calibration (binary number)
ST_CAL_FIN_p p = APLL0, APLL1, APLL2, RFPLL	R/O	0	PLL calibration finish status 0 = PLL calibration is not finished 1 = PLL calibration is finished
ST_CAL_OV_p p = APLL0, APLL1, APLL2, RFPLL	R/O	0	PLL calibration overflow status 0 = PLL calibration without overflow 1 = PLL calibration with overflow
ST_LOCK_p p = APLL0, APLL1, APLL2, RFPLL	R/O	0	PLL lock status 0 = PLL is not locked 1 = PLL is locked

Initialization and Internal SYSREF Trigger

Table 123. Initialization and Internal SYSREF Trigger Field Locations

Address	D7	D6	D5	D4	D3	D2	D1	D0
0x0320	RELOCK							Reserved
0x0321	INIT_CLK_A							Reserved
0x0322	INIT_CLK_B							Reserved
0x0323	INIT_CLK_C							Reserved
0x0324	INIT_CLK_D							Reserved
0x0325	INIT_REF							Reserved

Table 124. Initialization and Internal SYSREF Trigger Field Descriptions

Bit Field Name	Field Type	Default Value	Description
RELOCK	W1AC	0	Re-start APLL calibration. Re-initializes calibration for <i>a</i> ll enabled APLLs. 0 = No calibration restart 1 = Re-lock the PLL calibration
INIT_CLK_A	W1AC	0	Resets and synchronizes the following frequency dividers: <ul style="list-style-type: none"> ▪ DPLL-0 feedback divider M ▪ DPLL-0 the post divider (P0) ▪ Output dividers N_d that are driven by DPLL-0/APLL-0 The divider reset is part of the a procedure to phase-align the DPLL-0 clock input to clock outputs driven by DPLL-0/APLL-0 (for information, see Input to Output Phase Alignment). During reset, the APLL-0 VCO clock is blocked from driving the dividers. Upon release from reset, the divider state machines are started at the same time and are synchronized to each other. 0 = No reset 1 = Reset/Synchronization
INIT_CLK_B	W1AC	0	Resets and synchronizes the following frequency dividers: <ul style="list-style-type: none"> ▪ DPLL-1 feedback divider M ▪ DPLL-1 the post divider (P0) The divider reset is part of the a procedure to phase-align the DPLL-1 clock input to clock outputs driven by DPLL-1/APLL-1 (for information, see Input to Output Phase Alignment). During reset, the APLL-1 VCO clock is blocked from driving the dividers. Upon release from reset, the divider state machines are started at the same time and are synchronized to each other. 0 = No reset 1 = Reset/Synchronization

Table 124. Initialization and Internal SYSREF Trigger Field Descriptions (Cont.)

Bit Field Name	Field Type	Default Value	Description
INIT_CLK_C	W1AC	0	<p>Resets and synchronizes the following frequency dividers:</p> <ul style="list-style-type: none"> ▪ APLL-2 feedback divider M ▪ Output dividers N_d that are driven by APLL-2 <p>The divider reset is part of the a procedure to phase-align the selected clock input to clock outputs driven by APLL-2 (for information, see Input to Output Phase Alignment). During reset, the APLL-2 VCO clock is blocked from driving the dividers. Upon release from reset, the divider state machines are started at the same time and are synchronized to each other.</p> <p>0 = No reset 1 = Reset/Synchronization</p>
INIT_CLK_D	W1AC	0	<p>Resets and synchronizes the following frequency dividers:</p> <ul style="list-style-type: none"> ▪ RF-PLL feedback divider M ▪ Output dividers N_x, N_r, N_D2, N_D3 that are driven by RF-PLL <p>The divider reset is part of the a procedure to phase-align the selected clock input to clock outputs driven by the RF-PLL (for information, see Input to Output Phase Alignment). During reset, the RF_PLL VCO clock is blocked from driving the dividers. Upon release from reset, the divider state machines are started at the same time and are synchronized to each other.</p> <p>0 = No reset 1 = Reset/Synchronization</p>
INIT_REF	W1AC	0	1 = Starts an initialization (synchronization) for the SYSREF divider N_S

Channel Enable and PLL Reference Registers Descriptions

Table 125. Channel Enable and PLL Reference Field Locations

Address	D7	D6	D5	D4	D3	D2	D1	D0
0x0326	EN_D0	EN_D1	EN_D2	EN_D3	EN_R5	EN_R4	EN_R3R2	EN_R1R0
0x0327	RDIV_SYSAPLL	RSEL_APLL0/1	RSEL_SYSAPLL	Reserved				QREF_ALL_EN

Table 126. Channel Enable Field Descriptions

Bit Field Name	Field Type	Default Value	Description
EN_D0	R/W	1	Output Enable QCLK_d (d = 0 to 3) 0 = Disabled 1 = Enabled
EN_D1	R/W	1	
EN_D2	R/W	1	
EN_D3	R/W	1	
EN_R5	R/W	1	Enable output QCLK_R5. 0 = Disabled 1 = Enabled
EN_R4	R/W	1	Enable output QCLK_R4. 0 = Disabled 1 = Enabled
EN_R3R2	R/W	1	Enable output QCLK_R2 and QCLK_R3 0 = Disabled 1 = Enabled
EN_R1R0	R/W	1	Enable output QCLK_R1 and QCLK_R0 0 = Disabled 1 = Enabled
RDIV_SYSAPLL	R/W	0	Reference clock divider for SYS-APLL 0 = $f_{REF,SYSAPLL} = f(\text{selected reference}) \div 2$ 1 = $f_{REF,SYSAPLL} = f(\text{selected reference}) \div 1$ Set to 1 if the selected reference frequency (OSCI/OSCO or XO_DLL input frequency, selected by RSEL_APLL0/1) is less than 27MHz, otherwise select $\div 2$.
RSEL_APLL0/1	R/W	1 Value: Select XO_DPLL input	Selects between crystal oscillator (OSCI/OSCO) and external oscillator (XO_DPLL) reference frequency source for APLL-0 and APLL-1. 0 = Select OSC (crystal oscillator) input as source 1 = Select XO_DPLL input as source

Table 126. Channel Enable Field Descriptions (Cont.)

Bit Field Name	Field Type	Default Value	Description
RSEL_SYSAPLL	R/W	0 Value: XO_DPLL input	Selects between crystal oscillator (OSC) and external oscillator (XO_DPLL) reference frequency source for the SYS-APLL. 0 = Select XO_DPLL input as source 1 = Select OSCI/OSCO (crystal oscillator) inputs as source
QREF_ALL_EN	R/W	0	Disables/Enables the QREF function. When enabled: Outputs are in low/high state if SYSREF_AC=0 and biased to midpoint if SYSREF_AC=1 0 = QREF function is disabled 1 = QREF function is enabled

Table 127. EEPROM Registers

Address	D7	D6	D5	D4	D3	D2	D1	D0
0x0337	EEPROM_VERSION							
0x0339	CHECKSUM[7:0]							

Electrical Characteristics

Table 128. EEPROM Registers Bit Field Descriptions

Bit Field Name	Field Type	Default Value	Description
EEPROM_VERSION	R	–	EEPROM version. The content of this register is copied from the EEPROM at the same offset address and acts as a EEPROM version register. Content of this register is also included in the checksum in register 0x0339. Values can only be read through the SPI and I3C/I2C interface, but not written.
CHECKSUM	R	–	EEPROM checksum including content of register 0x0337.

Absolute Maximum Ratings

The absolute maximum ratings are stress ratings only. Stresses greater than those listed below can cause permanent damage to the device. Functional operation of the 8V19N850 at absolute maximum ratings is not implied. Exposure to absolute maximum rating conditions may affect device reliability.

Table 129. Absolute Maximum Ratings

Item	Rating
Supply Voltage, V_{DD_V} , V_{DDO_V}	3.6V
Inputs	-0.5V to $V_{DD_V} + 0.5V$
Outputs, V_O (LVCMOS)	-0.5V to $V_{DDO_V} + 0.5V$
Outputs, I_O (LVPECL) Continuous Current Surge Current	50mA 100mA
Outputs, I_O (LVDS) Continuous Current Surge Current	50mA 100mA
Input termination current, I_{VT}	$\pm 35mA$
Junction Temperature, T_J	150°C
Storage Temperature, T_{STG}	-65°C to 150°C
ESD - Human Body Model ^a	2000V
ESD - Charged Device Model ^a	500V

a. According to JEDEC JS-001-2012/JESD22-C101

Table 130. Recommended Operating Conditions

Item	Rating
Supply Voltage, V_{DD_V}	3.3V
Supply Voltage, V_{DDO_V}	3.3V, 2.5V, 1.8V
Operating Junction Temperature, T_J ^a	$\leq 125^\circ C$
Board Temperature, T_B	$\leq 105^\circ C$

a. 125°C/10year lifetime is based on the evaluation of intrinsic wafer process technology reliability metrics. The limiting wafer level reliability factor for this technology with respect to high temperature operation is electromigration. The device is verified to the maximum operating junction temperature through simulation.

Pin Characteristics

Table 131. Pin Characteristics, $V_{DD_V} = 3.3V \pm 5\%$, $T_A = -40^\circ C$ to $+105^\circ C$ (Case)

Symbol	Parameter	Test Conditions	Minimum	Typical	Maximum	Units
C_{IN}^a	Input Capacitance			2	4	pF
		Other inputs		2	4	pF
R_{PU}	Input Pull-Up Resistor			51		k Ω
R_{PD}	Input Pull-Down Resistor			51		k Ω
R_{OUT}	LVC MOS Output Impedance			25		Ω

a. Guaranteed by design

External Oscillator Characteristics

Table 132. External Crystal/Oscillator Characteristics, $V_{DD_V} = 3.3V \pm 5\%$, $V_{DDO_V} = (3.3V, 2.5V, 1.8V) \pm 5\%$, $T_A = -40^\circ C$ to $+105^\circ C$ (Case) ^a

Symbol	Parameter	Test Conditions	Minimum	Typical	Maximum	Units
Crystal (OSCI, OSCO)						
	Mode of Oscillation		Fundamental			
f_{XTAL}	Crystal Frequency		25		54	MHz
ESR	Equivalent Series Resistance	$C_L = 12pF$			30	Ω
C_L	Load capacitance			12		pF
OSCI Overdriven by External Signal^b (OSCO is left open)						
f_{XO}	XO Frequency	To APLL-0, APLL-1 or APLL-2	25		100	MHz
		To SYS-APLL	10		54	MHz
XO_DPLL^c						
f_{TCXO}	XO Frequency	To SYS-DPLL	10		72 ^d	MHz

a. Electrical parameters are guaranteed over the specified ambient operating temperature range, which is established when the device is mounted in a test socket with maintained transverse airflow greater than 500 lfm. The device will meet specifications after thermal equilibrium has been reached under these conditions.

b. XO, TCXO, or OCXO. In this mode, the XO_DPLL is not used and the SYS-DPLL can be turned off.

c. TCXO or OCXO when used for SYS-DPLL only; otherwise, see f_{XO} for limits.

d. Based on $(SYS_CLK/3)*2$, where SYS_CLK is approximately 108MHz.

DC Characteristics

Table 133. Power Supply DC Characteristics, $T_A = -40^{\circ}\text{C}$ to $+105^{\circ}\text{C}$ (Case) ^a

Symbol	Parameter	Test Conditions	Minimum	Typical	Maximum	Units
V_{DD_V}	Core Supply Voltage	JESD8C-01 Narrow Range	3.135	3.3	3.465	V
V_{DDO_V}	Output Supply Voltage	JESD8C-01 Narrow Range	3.135	3.3	3.465	V
			2.375	2.5	2.625	V
			1.71	1.8	1.89	V
I_{DD_TOT}	Total Power Supply Current ^b	$V_{DD_V}=3.3\text{V}$, $V_{DDO_V} = 2.5\text{V}$ (except $V_{DDO_D0} = 3.3\text{V}$)		1.34	1.472	A
I_{DD_TOT}	Total Power Supply Current ^c	$V_{DD_V}=3.3\text{V}$, $V_{DDO_V} = 2.5\text{V}$		1.39	1.528	A
I_{DD_TOT}	Total Power Supply Current ^d	$V_{DD_V}=3.3\text{V}$, $V_{DDO_V} = 2.5\text{V}$ (except $V_{DDO_D2} = V_{DDO_D3} = 3.3\text{V}$)		1.57	1.725	A
I_{DD_TOT}	Total Power Supply Current ^e	$V_{DD_V}=3.3\text{V}$, $V_{DDO_V} = 3.3\text{V}$		1.48	1.626	A

a. Electrical parameters are guaranteed over the specified ambient operating temperature range, which is established when the device is mounted in a test socket with maintained transverse airflow greater than 500 lfm. The device will meet specifications after thermal equilibrium has been reached under these conditions.

b. Applicable to the default startup configuration 00

c. Applicable to the default startup configuration 01

d. Applicable to the default startup configuration 10

e. Applicable to the default startup configuration 11

Table 134. LVCMOS Input DC Characteristics, $V_{DD_V} = 3.3\text{V} \pm 5\%$, $V_{DDO_V} = (3.3\text{V}, 2.5\text{V}, 1.8\text{V}) \pm 5\%$, $T_A = -40^{\circ}\text{C}$ to $+105^{\circ}\text{C}$ (Case) ^a

Symbol	Parameter	Test Conditions	Minimum	Typical	Maximum	Units
Control Input SPI_SEL (LVCMOS Logic)						
V_{IH}	Input High Voltage		$0.65 \times V_{DDO_R5}$	$0.5 \times V_{DDO_R5}$	V_{DDO_R5}	V
V_{IL}	Input Low Voltage		-0.3		$0.35 \times V_{DDO_R5}$	V
I_{IH}	Input High Current	Input with pull-up resistor $V_{DD_V} = 3.3\text{V}$, $V_{IN} = 3.3\text{V}$			10	μA
I_{IL}	Input Low Current	$V_{DD_V} = 3.3\text{V}$, $V_{IN} = 0\text{V}$	-150			μA
SYSREF Trigger Input EXT_SYS (LVCMOS Logic)						
V_{IH}	Input High Voltage	1.8V logic	1.17		V_{DD_V}	V
V_{IL}	Input Low Voltage	1.8V logic	-0.3		0.63	V

Table 134. LVCMOS Input DC Characteristics, $V_{DD_V} = 3.3V \pm 5\%$, $V_{DDO_V} = (3.3V, 2.5V, 1.8V) \pm 5\%$, $T_A = -40^\circ C$ to $+105^\circ C$ (Case) ^a

Symbol	Parameter		Test Conditions	Minimum	Typical	Maximum	Units
I_{IH}	Input High Current	Input with pull-down resistor	$V_{DD_V} = 3.3V, V_{IN} = 1.8V$ or $3.3V$			150	μA
I_{IL}	Input Low Current		$V_{DD_V} = 3.3V, V_{IN} = 0V$	-10			μA
SPI Inputs: SDI, SCLK, nCS (1.8V Logic with Input Hysteresis)							
V_I	Input Voltage			-0.3		V_{DD_V}	V
V_{T+}	Positive-going input threshold voltage			0.660		1.350	V
V_{T-}	Negative-going input threshold voltage			0.495		1.170	V
V_H	Hysteresis Voltage		$V_{T+} - V_{T-}$	0.165		0.780	V

a. Electrical parameters are guaranteed over the specified ambient operating temperature range, which is established when the device is mounted in a test socket with maintained transverse airflow greater than 500 lfm. The device will meet specifications after thermal equilibrium has been reached under these conditions.

Table 135. LVCMOS Output DC Characteristics, $V_{DD_V} = 3.3V \pm 5\%$, $V_{DDO_V} = (3.3V, 2.5V, 1.8V) \pm 5\%$, $T_A = -40^\circ C$ to $+105^\circ C$ (Case) ^a

Symbol	Parameter		Test Conditions	Minimum	Typical	Maximum	Units
QCLK_Dn (LVCMOS)							
V_{OH}	Output High Voltage	Per JESD8C-01	$V_{DDO_V} = 3.3V, I_{OH} = -8mA$	2.4			V
		Per JESD5-5A-01	$V_{DDO_V} = 2.5V, I_{OH} = -4mA$	1.7			V
		Per JESD8-7A	$V_{DDO_V} = 1.8V, I_{OH} = -4mA$	$V_{DDO_V} - 0.45$			V
V_{OL}	Output Low Voltage	Per JESD8C-01	$V_{DDO_V} = 3.3V, I_{OH} = -8mA$			0.40	V
		Per JESD5-5A-01	$V_{DDO_V} = 2.5V, I_{OH} = -4mA$			0.70	V
		Per JESD8-7A	$V_{DDO_V} = 1.8V, I_{OH} = -4mA$			0.45	V
Z_{OUT}	Output Impedance	QCLK_d_DS = 0 QCLK_d_DS = 1	$V_{DDO_V} = 3.3V$		15 8		Ω Ω
		QCLK_d_DS = 0 QCLK_d_DS = 1	$V_{DDO_V} = 2.5V$		16 9		Ω Ω
		QCLK_d_DS = 0 QCLK_d_DS = 1	$V_{DDO_V} = 1.8V$		20 11		Ω Ω

Table 135. LVCMOS Output DC Characteristics, $V_{DD_V} = 3.3V \pm 5\%$, $V_{DDO_V} = (3.3V, 2.5V, 1.8V) \pm 5\%$, $T_A = -40^\circ C$ to $+105^\circ C$ (Case)^a

Symbol	Parameter		Test Conditions	Minimum	Typical	Maximum	Units
SPI output SDO (1.8V/3.3V Selectable Logic)							
V_{OH}	Output High Voltage		1.8V logic (SELSV2 = 0) $I_{OH} = -4mA$	1.35			V
			3.3V logic (SELSV2 = 1) $I_{OH} = -4mA$	2.4			V
V_{OL}	Output Low Voltage		1.8V logic (SELSV2 = 0) $I_{OL} = 4mA$			0.45	V
			3.3V logic (SELSV2 = 1) $I_{OL} = 4mA$			0.4	V

a. Electrical parameters are guaranteed over the specified ambient operating temperature range, which is established when the device is mounted in a test socket with maintained transverse airflow greater than 500 lfm. The device will meet specifications after thermal equilibrium has been reached under these conditions.

Table 136. Differential Input DC Characteristics, $V_{DD_V} = V_{DDO_V} = 3.3V \pm 5\%$, $V_{DDO_V} = (3.3V, 2.5V, 1.8V) \pm 5\%$, $T_A = -40^\circ C$ to $+105^\circ C$ (Case)^a

Symbol	Parameter		Test Conditions	Minimum	Typical	Maximum	Units
I_{IH}	Input High Current	Inputs with pull-down resistor ^b	$V_{DD_V} = V_{IN} = 3.465V$			150	μA
		Inputs with pull-down/pull-up resistor ^c				150	μA
I_{IL}	Input Low Current	Inputs with pull-down resistor ^b	$V_{DD_V} = 3.465V, V_{IN} = 0V$	-10			μA
		Inputs with pull-up/pull-down resistor ^c		-150			μA

a. Electrical parameters are guaranteed over the specified ambient operating temperature range, which is established when the device is mounted in a test socket with maintained transverse airflow greater than 500 lfm. The device will meet specifications after thermal equilibrium has been reached under these conditions.

b. Non-Inverting inputs: CLK_n, XO_DPLL

c. Inverting inputs: nCLK_n, nXO_DPLL

Table 137. LVPECL DC Characteristics (QCLK_y, QREF_r, STYLE = 0), $V_{DD_V} = 3.3V \pm 5\%$, $V_{DDO_V} = (3.3V, 2.5V, 1.8V) \pm 5\%$, $T_A = -40^\circ C$ to $+105^\circ C$ (Case)^a

Symbol	Parameter	Test Conditions	Minimum	Typical	Maximum	Units
V _{OH}	Output High Voltage ^b	350mV Amplitude Setting		$V_{DDO_V} - 0.98$		V
		500mV Amplitude Setting		$V_{DDO_V} - 1.04$		V
		750mV Amplitude Setting ^c		$V_{DDO_V} - 1.06$		V
		1000mV Amplitude Setting ^d		$V_{DDO_V} - 1.12$		V
V _{OL}	Output Low Voltage ^b	350mV Amplitude Setting		$V_{DDO_V} - 1.32$		V
		500mV Amplitude Setting		$V_{DDO_V} - 1.56$		V
		750mV Amplitude Setting ^e		$V_{DDO_V} - 1.81$		V
		1000mV Amplitude Setting ^f		$V_{DDO_V} - 2.09$		V

- a. Electrical parameters are guaranteed over the specified ambient operating temperature range, which is established when the device is mounted in a test socket with maintained transverse airflow greater than 500 lfm. The device will meet specifications after thermal equilibrium has been reached under these conditions.
- b. LVPECL outputs terminated with 50Ω to $V_{DDO_V} - 1.5V$ (350mV amplitude setting), $V_{DDO_V} - 1.75V$ (500mV amplitude setting), $V_{DDO_V} - 2.0V$ (750mV amplitude setting), $V_{DDO_V} - 2.25V$ (1000mV amplitude setting)
- c. 750mV amplitude setting is available at $V_{DDO_V} = 3.3V$
- d. 1000mV amplitude setting is available at $V_{DDO_V} = 3.3V$
- e. 750mV amplitude setting is available at $V_{DDO_V} = 3.3V$
- f. 1000mV amplitude setting is available at $V_{DDO_V} = 3.3V$

Table 138. LVDS DC Characteristics (QCLK_d, QCLK_y, QREF_r, STYLE = 1), $V_{DD_V} = 3.3V \pm 5\%$, $V_{DDO_V} = (3.3V, 2.5V, 1.8V) \pm 5\%$, $T_A = -40^\circ C$ to $+105^\circ C$ (Case)^a

Symbol	Parameter	Test Conditions	Minimum	Typical	Maximum	Units	
V _{OS}	Offset Voltage ^b QCLK_d_VOS = 0 QCLK_y_VOS = 0 QREF_r_VOS = 0	$V_{DDO_V} = 3.3V$	350mV Amplitude Setting	1.92	2.2	2.55	V
			500mV Amplitude Setting	1.77	2.1	2.45	V
		$V_{DDO_V} = 2.5V$	350mV Amplitude Setting	1.17	1.4	1.70	V
			500mV Amplitude Setting	1.01	1.3	1.60	V
		$V_{DDO_V} = 1.8V$	350mV Amplitude Setting	0.47	0.7	0.95	V
			500mV Amplitude Setting	0.34	0.6	0.85	V
		Offset Voltage ^c	$V_{DDO_V} = 3.3V$	Any Amplitude Setting	1.13	1.25	1.54
ΔV_{OS}	V _{OS} Magnitude Change			10	70	mV	

- a. Electrical parameters are guaranteed over the specified ambient operating temperature range, which is established when the device is mounted in a test socket with maintained transverse airflow greater than 500 lfm. The device will meet specifications after thermal equilibrium has been reached under these conditions.
- b. V_{OS} changes with V_{DDO_V}
- c. V_{OS} is internally regulated to 1.25V.

AC Characteristics

Table 139. AC Characteristics, $V_{DD_V} = 3.3V \pm 5\%$, $V_{DDO_V} = (3.3V, 2.5V, 1.8V) \pm 5\%$, $T_A = -40^\circ C$ to $+105^\circ C$ (Case)^a

Symbol	Parameter		Test Conditions	Minimum	Typical	Maximum	Units
RF-PLL and Device Clock Domain (VCO = 2949.12MHz)							
f_{VCO}	VCO Frequency				2949.12		MHz
f_{OUT}	Output Frequency	RF-PLL Clock Outputs QCLK_y	QCLK_y, N = ÷1		2949.12		MHz
			QCLK_y, N = ÷6		491.52		MHz
				
			QCLK_y, any N		$2949.12 \div N$		MHz
				
		QCLK_y, N = ÷3072		0.96		MHz	
		RF-PLL SYSREF Outputs QCLK_r	QREF_r, N = ÷96		30.72		MHz
			QREF_r, N = ÷384		7.68		MHz
			QREF_r, N = ÷1536		1.92		MHz
				
QREF_r, N = ÷3072			0.96		MHz		
APLL-2, Digital Clock Domain, (VCO = 3600-3868MHz)							
f_{VCO}	VCO Frequency			3600		3868	MHz
DPLL-0/APLL-0 and DPLL-1/APLL-1							
f_{CLK}	Input Frequency		CLK_n	0.001 (1PPS ^b)		1000	MHz
f_{VCO}	VCO frequency		APLL-0	2450	2500	2580	MHz
			APLL-1	3932.16			
V_{IN}	Input Voltage Amplitude ^c	CLK_n		0.16		1.2	V
V_{DIFF_IN}	Differential Input Voltage Amplitude ^{c, d}	CLK_n		0.32		2.4	V
V_{CMR}	Common Mode Input Voltage			0.92		$V_{DD_V} - (V_{IN} / 2)$	V

Table 139. AC Characteristics, $V_{DD_V} = 3.3V \pm 5\%$, $V_{DDO_V} = (3.3V, 2.5V, 1.8V) \pm 5\%$, $T_A = -40^\circ C$ to $+105^\circ C$ (Case)^a

Symbol	Parameter		Test Conditions	Minimum	Typical	Maximum	Units
	Startup time	Configuration 00 & 10				100	ms
		Configuration 10	DPLL-0 Locked, CLK_0=156.25MHz 9.2PPM offset between local XO and input ($\leq 40ns$ MTIE per G.8262)		15 ^e		s
		Configuration 11	DPLL-0 & DPLL-1 Locked, CLK_1=15.36MHz 9.2PPM offset between local XO and input ($\leq 65ns$ MTIE per 3GPP TS 36.133)		15 ^f		s
Output Characteristics							
odc	Output Duty Cycle	QCLK_y, QREF_r	Any frequency	45	50	55	%
			$ t_{pH}-t_{pL} $ at 122.88, 245.76, 491.52MHz		0	150	ps
		QCLK_d	Any frequency	45	50	55	%
			$ t_{pH}-t_{pL} $ at 100, 125, 156.25, 312.5MHz			150	ps
t_R / t_F	Output Rise/Fall Time	QCLK_y, QCLK_r	LVDS, 20% to 80%	45		250	ps
		QCLK_d ^h	LVDS, 20% to 80%	45		250	ps
		QCLK_d (Normal slew rate, high drive strength setting)	LVC MOS, 20% to 80%	210		315	ps
		GPIO Outputs	LVC MOS, 20%-80%		0.59	1	ns
SR	Differential Output Slew Rate	QCLK_y, QCLK_r	LVPECL, $V_{DDO_V} = 3.3V$ LVDS, $V_{DDO_V} = 3.3V$	1.3			V/ns
		QCLK_d	LVPECL, $V_{DDO_V} = 3.3V$ LVDS, $V_{DDO_V} = 3.3V$	1.9			V/ns
SR	LVC MOS Output Slew Rate	QCLK_d, Normal slew rate	LVC MOS, $V_{DDO_V} = 3.3V$ QCLK_d_SR[1:0] = 00	3.7			V/ns
$V_{O(PP)}^i$	QCLK_y, QREF_r, LVPECL Output Voltage Amplitude, Peak-to-peak, see also Table 137	350mV Amplitude	491.52MHz		320		mV
		500mV Amplitude	491.52MHz		475		mV
		750mV Amplitude	491.52MHz		675		mV
		1000mV Amplitude	491.52MHz		875		mV

Table 139. AC Characteristics, $V_{DD_V} = 3.3V \pm 5\%$, $V_{DDO_V} = (3.3V, 2.5V, 1.8V) \pm 5\%$, $T_A = -40^\circ C$ to $+105^\circ C$ (Case)^a

Symbol	Parameter	Test Conditions	Minimum	Typical	Maximum	Units	
$V_{O(PP)}^j$	QCLK_d LVPECL Output Voltage Amplitude, Peak-to-peak, see also Table 137	350mV Amplitude	312.5MHz		320	mV	
		500mV Amplitude	312.5MHz		490	mV	
		750mV Amplitude	312.5MHz		675	mV	
		1000mV Amplitude	312.5MHz		880	mV	
V_{OD}^k	QCLK_y, QREF_r, LVDS Output Voltage Swing, Peak-to-peak, see also Table 138	350mV Amplitude	491.52MHz	240		400	mV
		500mV Amplitude	491.52MHz	375		600	mV
V_{OD}^l	QCLK_d, LVDS Output Voltage Swing, Peak-to-peak, see also Table 138	350mV Amplitude	312.5MHz	235		400	mV
		500mV Amplitude	312.5MHz	365		600	mV
	Output Phase Change for Hitless Reference Switching ^m	Switching to an input reference with frequency $\geq 960kHz$ ⁿ		100		300	ps
		Switching to an input reference with frequency $< 960kHz$ ^o		1		2.5	ns
RF-PLL Delay and Clock Phase Characteristics							
Δt_{PD}	Propagation delay <i>variation</i>	CLK_n to any QCLK_y, QCLK_r	-500		+500	ps	
		CLK_n to any QCLK_d	-500		+500	ps	
$t_{sk(o)}$	Output to output skew, outputs configured (static phase delay) for an incident edge	QCLK_y, QCLK_r to any QCLK_y, QCLK_r			74	ps	
		QCLK_d (LVDS)		50		ps	
		QCLK_y to any QCLK_d		60		ps	
t_{PD}	SYSREF Propagation delay	EXT_SYS to SYSREF output (SRG=000) ^p	0.8		2.2	ns	
t_S	SYSREF Setup Time	EXT_SYS to CLK_n (SRG = 001, configuration 01) ^q	-1			ns	
t_H	SYSREF Hold Time		6				
t_W	SYSREF Pulse Width		SRG = 010 or 100	4			
		SRG = 001	(4Nx/Fvco)				
$\Delta t_{sk(o)}$	Output to output skew variation (drift) over temperature	QCLK_y, QCLK_r to any QCLK_y, QCLK_r			1	ps/°C	
$\Delta\Phi$	Output isolation between any neighboring clock output	QCLK_Dn $f_{OUT} = 312.5MHz$		65	58.5	dB	
		QCLK_Rn, $f_{OUT} = 491.52MHz$		76	74.8	dB	

Table 139. AC Characteristics, $V_{DD_V} = 3.3V \pm 5\%$, $V_{DDO_V} = (3.3V, 2.5V, 1.8V) \pm 5\%$, $T_A = -40^\circ C$ to $+105^\circ C$ (Case)^a

Symbol	Parameter	Test Conditions	Minimum	Typical	Maximum	Units
$\Delta\Phi$	Output isolation between any QCLK_y, QREF_r output	Both SYSREF and clock signals active		70.5		dB
PSNR	Supply Noise Rejection ^f	10kHz		10		mV RMS
		100kHz		9		mV RMS
		1MHz		7		mV RMS
		10MHz		3		mV RMS
PSNR	Supply Noise Rejection	Sinusoidal signal injected. f=10Hz-1MHz		61.7		dB
		Sinusoidal signal injected: f=1MHz-40MHz		84.5		dB

- a. Electrical parameters are guaranteed over the specified ambient operating temperature range, which is established when the device is mounted in a test socket with maintained transverse airflow greater than 500 lfm. The device will meet specifications after thermal equilibrium has been reached under these conditions.
- b. Supports 1Hz / 1PPS utilizing a frequency snap and phase snap mechanism.
- c. V_{IL} should not be less than -0.3V and V_{IH} should not be greater than V_{DD_V}
- d. Common Mode Input Voltage is defined as the cross-point voltage.
- e. Based on default DPLL-0 settings for BW, damping, and lock threshold. Use of fast lock or tighter lock threshold will improve settling time.
- f. Based on default DPLL-0 and DPLL-1 settings for BW, damping, and lock threshold. Use of fast lock or tighter lock threshold will improve settling time.
- g. t_{pH} = High pulse period; t_{pL} = Low pulse period.
- h. Applicable to the default startup configurations 00 and 10.
- i. LVPECL outputs terminated with 50Ω to $V_{DDO_V} - 1.5V$ (350mV amplitude setting), $V_{DDO_V} - 1.75V$ (500mV amplitude setting), $V_{DDO_V} - 2.0V$ (750mV amplitude setting), $V_{DDO_V} - 2.25V$ (1000mV amplitude setting and $V_{DDO_V} = 3.3V$)
- j. LVPECL outputs terminated with 50Ω to $V_{DDO_V} - 1.5V$ (350mV amplitude setting), $V_{DDO_V} - 1.75V$ (500mV amplitude setting), $V_{DDO_V} - 2.0V$ (750mV amplitude setting), $V_{DDO_V} - 2.25V$ (1000mV amplitude setting and $V_{DDO_V} = 3.3V$)
- k. LVDS outputs terminated 100Ω across terminals.
- l. LVDS outputs terminated 100Ω across terminals.
- m. This parameter was measured with a low phase noise reference provided to the system APLL.
- n. Tested with 960kHz input reference, with modified Hitless Filter values (Avg = 7 and Shift = 16).
- o. Tested with 1kHz input reference, with modified Hitless Filter values (Avg = 7 and Shift = 14)
- p. Delay values in SYSREF path set to 0
- q. Configuration for SYSREF ext. trigger modes SRG=001: $f_{IN} = 30.72MHz$ and DPLL-1 locked using RF-PLL feedback, $f_{IN-RFPLL} = 122.88MHz$, delay stages set to 0, SYSREF = 7.68MHz. See Figure 23 for setup and hold time definition.
- r. PSNR is measured at a differential output pair with the criteria: output spurious specification is met with an injected sinusoidal signal at the specified frequency and amplitude.

Figure 23. EXT_SYS Input Timing Diagram (SRG = 001)

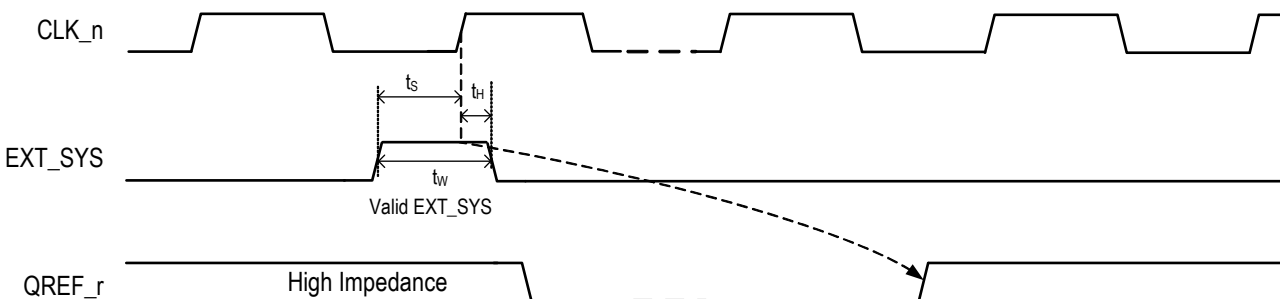

Table 140. RF-PLL Device Clock Domain QCLK_y Clock Phase Noise Characteristics, $V_{DD_V} = 3.3V \pm 5\%$, $T_A = -40^\circ C$ to $+105^\circ C$ (Case) ^{a b c d}

Symbol	Parameter		Test Conditions	Minimum	Typical	Maximum	Units		
$\text{jit}(\emptyset)$	RMS Phase Jitter (Random) RF-PLL Clock on QCLK_y, 491.52MHz		Integration Range: 1kHz – 100MHz Default configuration 00 Default configuration 01		168 144		fs		
			Integration Range: 10kHz – 20MHz Default configuration 00 Default configuration 01		147 123	250	fs		
$\text{jit}(\emptyset)$	RMS Phase Jitter (Random) RF-PLL Clock on QCLK_y, 245.76MHz		Integration Range: 10kHz – 20MHz Default configuration 10		129	250	fs		
$\text{jit}(\emptyset)$	RMS Phase Jitter (Random) RF-PLL Clock on QCLK_y, 122.88MHz		Integration Range: 10kHz – 20MHz Default configuration 00 Default configuration 01 Default configuration 10 Default configuration 11		159 136 141 162	250	fs		
$\emptyset(10)$	Clock Single-side Band Phase Noise	QCLK_y, 491.52MHz ^{e, f}	10Hz offset		-81.4		dBc/Hz		
$\emptyset(100)$			100Hz offset		-108		dBc/Hz		
$\emptyset(500)$			500Hz offset from carrier		-118.8		dBc/Hz		
$\emptyset(1k)$			1kHz offset from carrier		-120.9	-117.5	dBc/Hz		
$\emptyset(10k)$			10kHz offset from carrier		-125	-122.1	dBc/Hz		
$\emptyset(100k)$			100kHz offset from carrier		-128.8	-127.8	dBc/Hz		
$\emptyset(300k)$			300kHz offset from carrier		-132.4	-131.5	dBc/Hz		
$\emptyset(1M)$			1MHz offset from carrier		-140.6	-137.9	dBc/Hz		
$\emptyset(2M)$			2MHz offset from carrier		-152.7	-150.5	dBc/Hz		
$\emptyset(10M)$			10MHz offset from carrier		-157.7	-155.6	dBc/Hz		
$\emptyset(\geq 20M)$			≥ 20 MHz offset from carrier and noise floor		-158.3	-156	dBc/Hz		
$\emptyset(1)$			Clock Single-side Band Phase Noise	QCLK_y, 245.76MHz ^g	1Hz offset		-56.6		dBc/Hz
$\emptyset(10)$					10Hz offset		-85.5		dBc/Hz
$\emptyset(100)$	100Hz offset from carrier				-113.3		dBc/Hz		
$\emptyset(1k)$	1kHz offset from carrier				-126	-120	dBc/Hz		
$\emptyset(10k)$	10kHz offset from carrier				-127	-123	dBc/Hz		
$\emptyset(100k)$	100kHz offset from carrier				-132.9	-131	dBc/Hz		
$\emptyset(300k)$	300kHz offset from carrier				-140.4	-137	dBc/Hz		
$\emptyset(1M)$	1MHz offset from carrier				-149.4	-144	dBc/Hz		
$\emptyset(2M)$	2MHz offset from carrier				-156.7	-153	dBc/Hz		
$\emptyset_N(10M)$	10MHz offset from carrier				-159.1	-157	dBc/Hz		
$\emptyset_N(\geq 20M)$	≥ 20 MHz offset from carrier and noise floor				-160.3	-155	dBc/Hz		

Table 140. RF-PLL Device Clock Domain QCLK_y Clock Phase Noise Characteristics, $V_{DD_V} = 3.3V \pm 5\%$, $T_A = -40^\circ C$ to $+105^\circ C$ (Case) ^{a b c d} (Cont.)

Symbol	Parameter		Test Conditions	Minimum	Typical	Maximum	Units	
$\emptyset(1)$	Clock Single-side Band Phase Noise	QCLK_y, 122.88MHz ^h	1Hz offset		-65.1		dBc/Hz	
$\emptyset(10)$			10Hz offset		-91.3		dBc/Hz	
$\emptyset(100)$			100Hz offset from carrier		-117.8		dBc/Hz	
$\emptyset(1k)$			1kHz offset from carrier		-130.4	-126.2	dBc/Hz	
$\emptyset(10k)$			10kHz offset from carrier		-132.1	-129.3	dBc/Hz	
$\emptyset(100k)$			100kHz offset from carrier		-137.9	-135	dBc/Hz	
$\emptyset(300k)$			300kHz offset from carrier		-145.1	-141.2	dBc/Hz	
$\emptyset(1M)$			1MHz offset from carrier		-155.5	-148.2	dBc/Hz	
$\emptyset(2M)$			2MHz offset from carrier		-161.8	-158	dBc/Hz	
$\emptyset_N(10M)$			10MHz offset from carrier		-164.4	-162.5	dBc/Hz	
$\emptyset_N(\geq 20M)$			$\geq 20MHz$ offset from carrier and noise floor			-165	-163.3	dBc/Hz

Table 140. RF-PLL Device Clock Domain QCLK_y Clock Phase Noise Characteristics, $V_{DD_V} = 3.3V \pm 5\%$, $T_A = -40^\circ C$ to $+105^\circ C$ (Case) ^{a b c d} (Cont.)

Symbol	Parameter		Test Conditions	Minimum	Typical	Maximum	Units	
∅	Spurious Signal Rejection (QCLK, QREF as clock)	491.52MHz	2Hz – <100Hz Default configuration 00 Default configuration 01		58.6 55.7		dB	
			100Hz – <1kHz Default configuration 00 Default configuration 01		99.1 96.1		dB	
			1kHz – <983.04MHz Default configuration 00 Default configuration 01		68.2 77.1		dB	
		245.76MHz ^[g]	2Hz – <100Hz		62.5		dB	
			100Hz – <1kHz		103		dB	
			1kHz – <491.52MHz		83		dB	
		122.88MHz	2Hz – <100Hz Default configuration 00 Default configuration 01 Default configuration 10 Default configuration 11		60.4 65.6 63.8 65.5		dB	
				100Hz – <1kHz Default configuration 00 Default configuration 01 Default configuration 10 Default configuration 11		104.9 103.5 104.7 87.5		dB
				1kHz – <245.76MHz Default configuration 00 Default configuration 01 Default configuration 10 Default configuration 11		74.4 81.3 91.5 79.8		dB
	Harmonic rejection		491.52MHz ^[e] ^[f]	Even order harmonics		47.5		dB
			245.76MHz ^[g]			49.0		dB
			122.88MHz ^[h]			50.3		dB

- a. Phase noise and spurious specifications apply for device operation with QREF_r outputs active (SYSREF pulses generated). Phase noise specifications are applicable for all outputs active, N_x dividers not equal.
- b. Electrical parameters are guaranteed over the specified ambient operating temperature range, which is established when the device is mounted in a test socket with maintained transverse airflow greater than 500lfpm. The device will meet specifications after thermal equilibrium has been reached under these conditions.
- c. Phase noise characteristics at lower frequency offsets (1Hz ~1kHz) is primarily a function of the TCXO phase noise. TXCO: MX-503: -65dBc/Hz at 1Hz, -93dBc/Hz at 10Hz, -118dBc/Hz at 100Hz, -140dBc/Hz at 1kHz.
- d. Test conditions and data are based on the default configurations. The phase noise performance can be improved by optimization of the configuration and/or re-arrangement of clock outputs. For more information, please contact Renesas.
- e. Configuration 00
- f. Configuration 01
- g. Configuration 10
- h. Configuration 11

Table 141. Digital Clock Domain QCLK_d Clock Phase Noise Characteristics, $V_{DD_V} = 3.3V \pm 5\%$, $T_A = -40^\circ C$ to $+105^\circ C$ (Case)^{a b c d}

Symbol	Parameter		Test Conditions	Minimum	Typical	Maximum	Units
$\text{jit}(\emptyset)$	RMS Phase Jitter (Random) DPLL-0 (2500MHz) Clock on QCLK_d, 312.5MHz		Integration Range: 10kHz – 20MHz Default configuration 00 Default configuration 01		292 285		fs
$\text{jit}(\emptyset)$	RMS Phase Jitter (Random) DPLL-0 (2500MHz) Clock on QCLK_d, 156.25MHz		Integration Range: 10kHz – 20MHz Default configuration 10 Default configuration 11		257 253		fs
$\emptyset(100)$	Clock Single-side Band Phase Noise	QCLK_d, 100MHz ^{e,f}	100Hz offset from carrier		-121		dBc/Hz
$\emptyset(1k)$			1kHz offset from carrier		-136.4	-133	dBc/Hz
$\emptyset(10k)$			10kHz offset from carrier		-139.1	-132	dBc/Hz
$\emptyset(100k)$			100kHz offset from carrier		-142.9	-141	dBc/Hz
$\emptyset(1M)$			1MHz offset from carrier		-156.4	-154	dBc/Hz
$\emptyset(\geq 10M)$			$\geq 10MHz$ offset from carrier and noise floor		-162.1	-160	dBc/Hz
$\emptyset(100)$	Clock Single-side Band Phase Noise	QCLK_d, 156.25MHz ^g	100Hz offset		-118.6		dBc/Hz
$\emptyset(1k)$			1kHz offset from carrier		-131.8	-126	dBc/Hz
$\emptyset(10k)$			10kHz offset from carrier		-134.5	-130	dBc/Hz
$\emptyset(100k)$			100kHz offset from carrier		-137.6	-135	dBc/Hz
$\emptyset(1M)$			1MHz offset from carrier		-150.8	-147	dBc/Hz
$\emptyset(\geq 10M)$			$\geq 10MHz$ offset from carrier and noise floor		-155.3	-152	dBc/Hz
$\emptyset(100)$	Clock Single-side Band Phase Noise	QCLK_d, 156.25MHz ^h	100Hz offset		-113.9		dBc/Hz
$\emptyset(1k)$			1kHz offset from carrier		-127.1	-120	dBc/Hz
$\emptyset(10k)$			10kHz offset from carrier		-129.7	-123	dBc/Hz
$\emptyset(100k)$			100kHz offset from carrier		-135.4	-131	dBc/Hz
$\emptyset(1M)$			1MHz offset from carrier		-149	-143	dBc/Hz
$\emptyset(\geq 10M)$			$\geq 10MHz$ offset from carrier and noise floor		-154.2	-152	dBc/Hz

Table 141. Digital Clock Domain QCLK_d Clock Phase Noise Characteristics, $V_{DD_V} = 3.3V \pm 5\%$, $T_A = -40^\circ C$ to $+105^\circ C$ (Case) ^{a b c d} (Cont.)

Symbol	Parameter		Test Conditions	Minimum	Typical	Maximum	Units
$\emptyset(100)$	Clock Single-side Band Phase Noise	QCLK_d, 312.5MHz ^{[e][f]}	100Hz offset		-112.3		dBc/Hz
$\emptyset(1k)$			1kHz offset from carrier		-126.6	-122	dBc/Hz
$\emptyset(10k)$			10kHz offset from carrier		-129.1	-125	dBc/Hz
$\emptyset(100k)$			100kHz offset from carrier		-133	-131	dBc/Hz
$\emptyset(1M)$			1MHz offset from carrier		-147.8	-144	dBc/Hz
$\emptyset(\geq 10M)$			$\geq 10MHz$ offset from carrier and noise floor		-158.7	-155	dBc/Hz
\emptyset	Spurious Signal Rejection (QCLK_d)	312.5MHz	100Hz – 625MHz Default configuration 00 Default configuration 01		63.6 60.6		dB
		156.25MHz	100Hz – 312.5MHz Default configuration 10 Default configuration 11		64.4 56.6		dB
		100MHz	100Hz – 200MHz Default configuration 00 Default configuration 01		66.7 66.7		dB

- a. Phase noise and spurious specifications apply for device operation with QREF_r outputs active (SYSREF pulses generated). Phase noise specifications are applicable for all outputs active, N_x dividers not equal.
- b. Electrical parameters are guaranteed over the specified ambient operating temperature range, which is established when the device is mounted in a test socket with maintained transverse airflow greater than 500lfpm. The device will meet specifications after thermal equilibrium has been reached under these conditions.
- c. Phase noise characteristics at lower frequency offsets (1Hz ~1kHz) is primarily a function of the TCXO phase noise. TXCO: MX-503: -65dBc/Hz at 1Hz, -93dBc/Hz at 10Hz, -118dBc/Hz at 100Hz, -140dBc/Hz at 1kHz.
- d. Test conditions and data are based on the default configurations. The phase noise performance can be improved by optimization of the configuration and/or re-arrangement of clock outputs. For more information, please contact Renesas.
- e. Configuration 00
- f. Configuration 01
- g. Configuration 10
- h. Configuration 11

Table 142. SPI Interface AC Characteristics, $V_{DD_V} = 3.3V \pm 5\%$, $V_{DDO_V} = (3.3V, 2.5V, 1.8V) \pm 5\%$, $T_A = -40^\circ C$ to $+105^\circ C$ (Case)^a

Symbol	Parameter	Test Condition	Minimum	Maximum	Unit
f_{SCLK}	SCLK Frequency			20	MHz
T_{SCLK}	SCLK Clock Period		50		ns
t_{S1}	Setup Time, nCS (falling) to SCLK (rising)		10		ns
t_{S2}	Setup Time, SDIO (input) to SCLK (rising)		8		ns
t_{H1}	Hold Time, SCLK (rising) to nCS (rising)		30		ns
t_{H2}	Hold Time, SCLK (rising) to SDIO (input)		8		ns
t_{H3}	Hold Time, SCLK (falling) to nCS (rising)		8		ns
t_{PDF}	Propagation Delay, SCLK (falling) to SDIO (output in 3-wire mode) or SDO (in 4-wire mode)	CPOL = 0		10	ns
t_{PDR}	Propagation Delay, SCLK (rising) to SDIO (output in 3-wire mode) or SDO (in 4-wire mode)	CPOL = 1		10	ns

a. Electrical parameters are guaranteed over the specified ambient operating temperature range, which is established when the device is mounted in a test socket with maintained transverse airflow greater than 500 lfm. The device will meet specifications after thermal equilibrium has been reached under these conditions.

Figure 24. SPI Timing Diagram

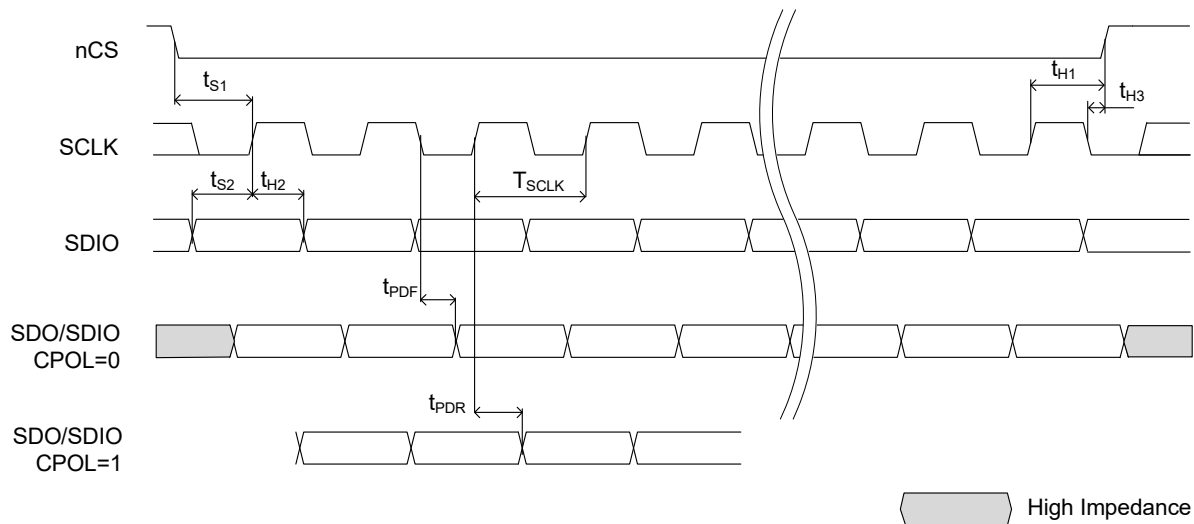

Table 143. I3C Interface AC Characteristics, $V_{DD_V} = 3.3V \pm 5\%$, $V_{DDO_V} = (3.3V, 2.5V, 1.8V) \pm 5\%$, $T_A = -40^\circ C$ to $+105^\circ C$ (Case)^a

Symbol	Parameter	Test Conditions	Minimum	Typical	Maximum	Units
I3CSDR Mode (Push-Pull Timing Parameters)						
f_{SCL}	SCL Clock Frequency		0.01	12.5	12.9	MHz
t_{LOW}	SCL Clock Low Period		24			ns
t_{DIG_L}			32			ns
t_{HIG}	SCL Clock High Period		24			ns
t_{DIG_H}			32			ns
t_{SCO}	Clock in to Data Out (Slave)				17.5 ^b	ns
t_{CR}	SCL Clock Rise Time				60	ns
t_{CF}	SCL Clock Fall Time				60	ns
t_{HD_PP}	SDA Signal Data Hold Time		2 ^c			ns
t_{SU_PP}	SDA Signal Data Setup Time		3			ns
C_b	Capacitive Load per Bus Line (SDA, SCL)				50	pF

a. Electrical parameters are guaranteed over the specified ambient operating temperature range, which is established when the device is mounted in a test socket with maintained transverse airflow greater than 500 lfpm. The device will meet specifications after thermal equilibrium has been reached under these conditions.

b. I3C specification is 12ns

c. I3C specification is 0ns

Figure 25. I3C Interface Timing Diagram for SCL (SDR Mode)

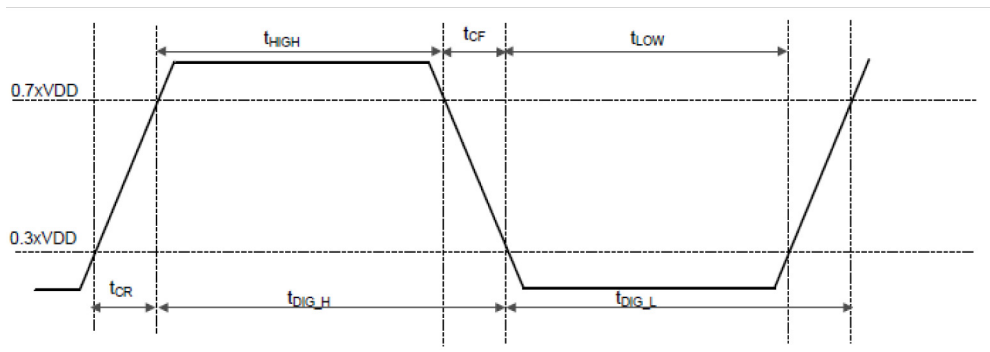

Figure 26. I3C Timing Diagram for Slave Output (SDA)

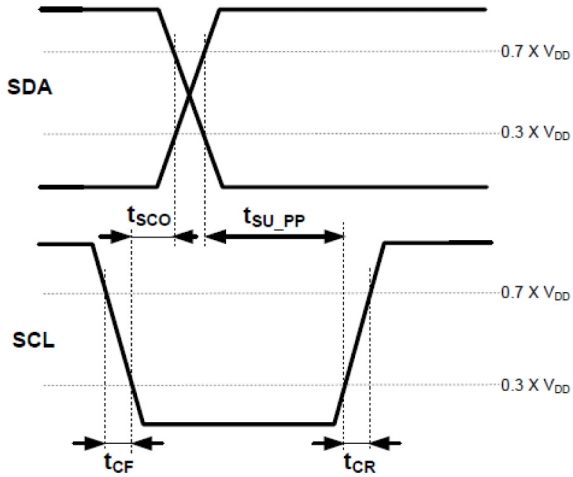

Figure 27. I3C Timing Diagram for Slave Output (SDA)

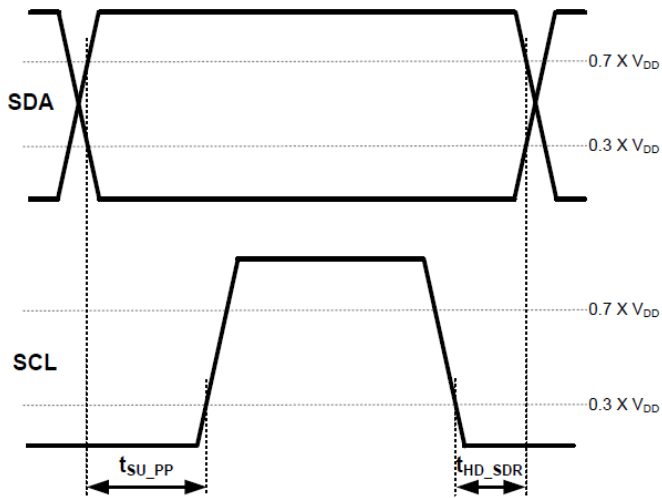

Figure 28. Legacy I²C Slave Timing Diagram

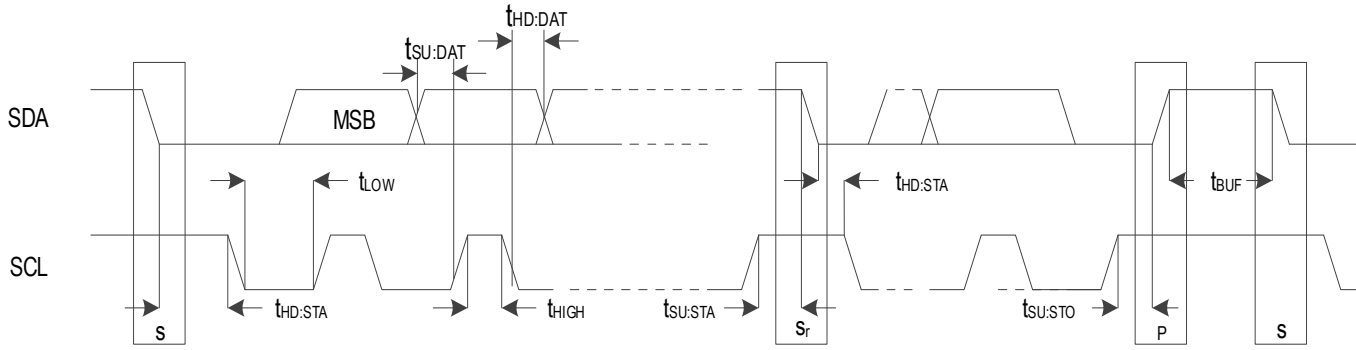

Table 144. Legacy I2C Interface AC Characteristics, $V_{DD_V} = 3.3V \pm 5\%$, $V_{DDO_V} = (3.3V, 2.5V, 1.8V) \pm 5\%$, $T_A = -40^\circ C$ to $+105^\circ C$ (Case)^a

Parameter	Description	Fast-mode		Fast-mode Plus		Units
		Minimum	Maximum	Minimum	Maximum	
f_{SCL}	SCL clock frequency	0	400	0	1000	kHz
$t_{HD:STA}$	Hold time (repeated) START condition	600	-	260	-	ns
t_{LOW}	LOW period of the SCL clock	1300	-	500	-	ns
t_{HIGH}	HIGH period of the SCL clock	600	-	260	-	ns
$t_{SU:STA}$	Set-up time for a repeated START condition	600	-	260	-	ns
$t_{HD:DAT}$	Data hold time ^b	0 ^c	- ^d	0	-	ns
$t_{SU:DAT}$	Data set-up time	100 ^e	-	50	-	ns
$t_{SU:STO}$	Set-up time for STOP condition	600	-	260	-	ns
t_{BUF}	Bus free time between a STOP and START condition	1300	-	500	-	ns
t_r	Rise time of both SDA and SCL signals	20	300	-	120	ns
t_f	Fall time of both SDA and SCL signals ^{fghi}	$20 \times (V_{DD_V} / 5.5 V)$	300	$20 \times (V_{DD_V} / 5.5 V)^j$	120 ^{li}	ns

- a. Electrical parameters are guaranteed over the specified ambient operating temperature range, which is established when the device is mounted in a test socket with maintained transverse airflow greater than 500 lfm. The device will meet specifications after thermal equilibrium has been reached under these conditions.
- b. $t_{HD:DAT}$ is the data hold time that is measured from the falling edge of SCL, applies to data in transmission and the acknowledge.
- c. A device must internally provide a hold time of at least 300 ns for the SDA signal (with respect to the $V_{IH}(\min)$ of the SCL signal) to bridge the undefined region of the falling edge of SCL.
- d. The maximum $t_{HD:DAT}$ could be 3.45 μs and 0.9 μs for Standard-mode and Fast-mode, but must be less than the maximum of $t_{VD:DAT}$ or $t_{VD:ACK}$ by a transition time. This maximum must only be met if the device does not stretch the LOW period (t_{LOW}) of the SCL signal. If the clock stretches the SCL, the data must be valid by the set-up time before it releases the clock.
- e. A Fast-mode I2C-bus device can be used in a Standard-mode I2C-bus system, but the requirement $t_{SU:DAT}$ 250 ns must then be met. This will automatically be the case if the device does not stretch the LOW period of the SCL signal. If such a device does stretch the LOW period of the SCL signal, it must output the next data bit to the SDA line $t_r(\max) + t_{SU:DAT} = 1000 + 250 = 1250$ ns (according to the Standard-mode I2C-bus specification) before the SCL line is released. Also the acknowledge timing must meet this set-up time.
- f. A device must internally provide a hold time of at least 300 ns for the SDA signal (with respect to the $V_{IH}(\min)$ of the SCL signal) to bridge the undefined region of the falling edge of SCL.

- g. If mixed with Hs-mode devices, faster fall times are allowed.
- h. The maximum t_f for the SDA and SCL bus lines is specified at 300 ns. The maximum fall time for the SDA output stage t_f is specified at 250 ns. This allows series protection resistors to be connected in between the SDA and the SCL pins and the SDA/SCL bus lines without exceeding the maximum specified t_f .
- i. In Fast-mode Plus, fall time is specified the same for both output stage and bus timing. If series resistors are used, designers should allow for this when considering bus timing.
- j. Necessary to be backwards compatible to Fast-mode.

Application Information

Termination for QCLK_y, QREF_r LVDS Outputs (STYLE = 0)

Figure 29 shows an example termination for the QCLK_y, QREF_r LVDS outputs. In this example, the characteristic transmission line impedance is 50Ω . The termination resistor R (100Ω) is matched to the line impedance. The termination resistor must be placed at the line end. No external termination resistor is required if R is an internal part of the receiver circuit. The LVDS termination in Figure 29 is applicable for any output amplitude setting specified in Table 23.

Figure 29. LVDS (STYLE = 0) Output Termination

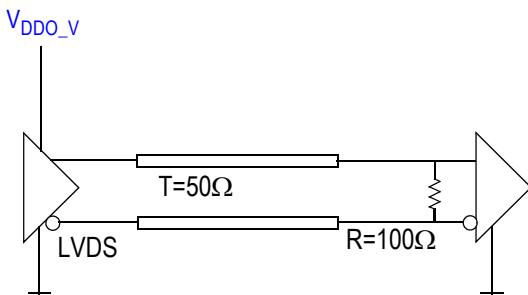

AC Termination for QCLK_y, QREF_r LVDS Outputs (STYLE = 0)

Figure 30 and Figure 31 show example AC terminations for the QCLK_y, QREF_r LVDS outputs. In the examples, the characteristic transmission line impedance is 50Ω . In Figure 30, the termination resistor R (100Ω) is placed at the line end. No external termination resistor is required if R is an internal part of the receiver circuit, which is shown in Figure 30. The LVDS terminations in both Figure 30 and Figure 31 are applicable for any output amplitude setting specified in Table 23. The receiver input should be re-biased according to its common mode range specifications.

Figure 30. LVDS (STYLE = 0) AC Output Termination

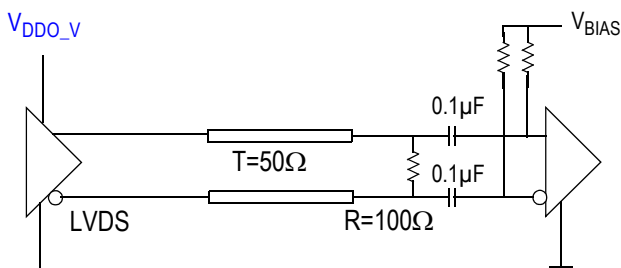
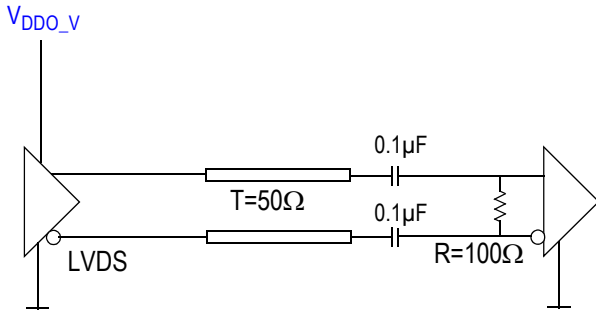

Figure 31. LVDS (STYLE = 0) AC Output Termination



Termination for QCLK_y, QREF_r LVPECL Outputs (STYLE = 1)

Figure 32 shows an example termination for the QCLK_y, QREF_r LVPECL outputs. In this example, the characteristic transmission line impedance is 50Ω. The R1 (50Ω) and R2 (50Ω) resistors are matched load terminations. The output is terminated to the termination voltage V_T . The V_T must be set according to the output amplitude setting defined in Table 23. The termination resistors must be placed close at the line end.

Figure 32. LVPECL (STYLE = 1) Output Termination

$$V_T = V_{DDO_V} - 1.50V \text{ (350mV Amplitude)}$$

$$V_T = V_{DDO_V} - 1.75V \text{ (500mV Amplitude)}$$

$$V_T = V_{DDO_V} - 2.00V \text{ (750mV Amplitude)}$$

$$V_T = V_{DDO_V} - 2.25V \text{ (1000mV Amplitude)}$$

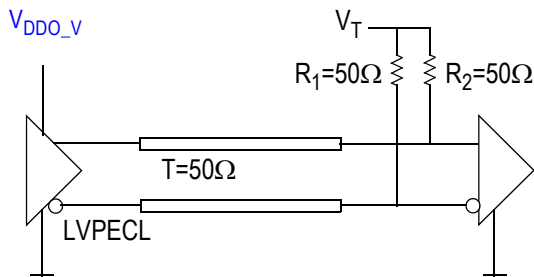

Thermal Characteristics

The 8V19N850 is a multi-functional, high-speed device that targets a wide variety of clock frequencies and applications. Since this device is highly programmable with a broad range of features and functionality, the power consumption will vary as each of these features and functions is enabled. The device was designed and characterized to operate within the board temperature range of -40°C to +105°C. The ambient temperature represents the temperature around the device, not the junction temperature. When using the device in extreme cases, such as maximum operating frequency and high ambient temperature, external air flow may be required in order to ensure a safe and reliable junction temperature. Extreme care must be taken to avoid exceeding 125°C junction temperature. For any concerns on calculating the power dissipation for your own specific configuration, please contact Renesas technical support.

Table 145. Thermal Characteristics for the 88-VFQFPN Package^a

Multi-Layer PCB, JEDEC Standard Test Board				
Symbol	Thermal Parameter	Condition	Value	Unit
Θ_{JA}	Junction to ambient	0 m/s air flow	21.7	°C/W
		1 m/s air flow	18.2	
		2 m/s air flow	16.9	
		3 m/s air flow	16	
		4 m/s air flow	15.7	
		5 m/s air flow	15.5	
Θ_{JC}	Junction to case	—	10	
Θ_{JB}	Junction to board	—	0.3	

a. Standard JEDEC 2S2P multilayer PCB

Case Temperature Considerations

The device supports applications in a natural convection environment as long as the junction temperature does not exceed the specified junction temperature, T_J . In applications where the heat dissipates through the PCB, Θ_{JB} is the correct metric to calculate the junction temperature. Θ_{JB} is the right metric in all other applications where the majority of the heat dissipates through the board (80%) and a minority (20%) through the top of the device. The following calculation uses the junction-to-board thermal characterization parameter Θ_{JB} to calculate the junction temperature, T_J . Care must be taken to not exceed the maximum allowed junction temperature, $T_{J, MAX}$ of 125 °C.

The junction temperature T_J is calculated using the following equation:

$$T_J = T_B + \Theta_{JB} \times P_D, \text{ where}$$

- T_J Junction temperature at steady state condition in (°C).
- T_B Case temperature (Bottom) at steady state condition in (°C).
- Θ_{JB} Thermal characterization parameter to report the difference between T_J and T_B
- P_D Total power dissipation (W)

The 8V19N850 Maximum power dissipation scenario: With the maximum allowed junction temperature, the maximum device power consumption and at the maximum supply voltage of 3.3V + 5%, the maximum supported board temperature can be determined. In this example, the part is configured to GPIO[1:0]=00 or GPIO[1:0]=10. The the maximum current consumption, I_{DD_TOT} is 1432mA (see [Table 133](#)):

- Total system power dissipation (including termination resistor power): $P_{TOT} = V_{DD_V, MAX} \times I_{DD_V, MAX} = 3.465V \times 1432mA = 4.96W$
- Total device power dissipation (excluding termination resistor power): $P_{TOT} = 4.94W$

In this scenario and with the Θ_{JB} thermal model, the maximum supported board temperature is:

- $T_{B, MAX} = T_{J, MAX} - \Theta_{JB} \times P_{TOT}$
- $T_{B, MAX} = 125^\circ\text{C} - 0.3^\circ\text{C/W} \times 4.94W$
- $T_{B, MAX} = 123.5^\circ\text{C}$

From above calculation and for the default device configuration of GPIO[1:0] = 00 or GPIO[1:0] = 10 at the maximum power dissipation, the board temperature must be kept below 123.5°C. It is recommended to keep the board temperature below 105°C for an additional margin. The board layout must have sufficient path for heat release from the package exposed pad through the whole board (e.g., via holes surrounding part that causes exposed pad islands should be avoided). Please refer to the application note for further recommendation. It is recommended to apply a thermal analysis for actual application board.

Package Exposed Pad Thermal Release Path

In order to maximize both the removal of heat from the package and the electrical performance, a land pattern must be incorporated on the Printed Circuit Board (PCB) within the footprint of the package corresponding to the exposed metal pad or exposed heat slug on the package. The solderable area on the PCB, as defined by the solder mask, should be at least the same size/shape as the exposed pad/slug area on the package to maximize the thermal/electrical performance. Sufficient clearance should be designed on the PCB between the outer edges of the land pattern and the inner edges of pad pattern for the leads to avoid any shorts.

Figure 33. Assembly for Exposed Pad Thermal Release Path – Side View (Drawing not to Scale)

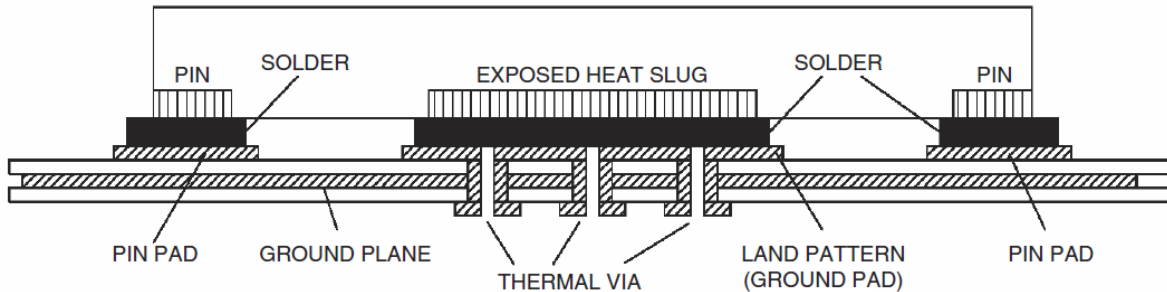

While the land pattern on the PCB provides a means of heat transfer and electrical grounding from the package to the board through a solder joint, thermal vias are necessary to effectively conduct from the surface of the PCB to the ground plane(s). The land pattern must be connected to ground through these vias. The vias act as “heat pipes.” The number of vias (i.e., “heat pipes”) are application-specific and are dependent upon the package power dissipation as well as electrical conductivity requirements. Thus, thermal and electrical analysis and/or testing are recommended to determine the minimum number needed. Maximum thermal and electrical performance is achieved when an array of vias is incorporated in the land pattern. It is recommended to use as many vias connected to ground as possible. It is also recommended that the via diameter should be 12 to 13 mils (0.30 to 0.33 mm) with 1oz copper via barrel plating. This is desirable to avoid any solder wicking inside the via during the soldering process which may result in voids in solder between the exposed pad/slug and the thermal land. Precautions should be taken to eliminate any solder voids between the exposed heat slug and the land pattern.

Note: These recommendations are to be used as a guideline only. For more information, refer to the application note on the Surface Mount Assembly of Amkor’s Thermally/Electrically Enhance Lead-frame Base Package, Amkor Technology.

Package Outline Drawings

The package outline drawings are located at the end of this document and are accessible from the Renesas website. The package information is the most current data available and is subject to change without revision of this document.

Marking Diagram



1. Lines 1 and 2 indicate the part number.
2. Line 3 indicates the following:
 - “#” denotes stepping.
 - “YY” is the last two digits of the year; “WW” is the work week number when the part was assembled.
 - “\$” denotes the mark code.

Ordering Information

Table 146. Ordering Information

Orderable Part Number	Package	Shipping Packaging	Board Temperature
8V19N850DNLGI	RoHS 6/6 88-VFQFPN, 10 × 10 mm	Tray	-40°C to +105°C
8V19N850DNLGI8		Tape & Reel, Pin 1 Orientation: EIA-481-C	
8V19N850DNLGI/W		Tape & Reel, Pin 1 Orientation: EIA-481-D/E	

Table 147. Pin 1 Orientation in Tape and Reel Packaging

Part Number Suffix	Pin 1 Orientation	Illustration
8	Quadrant 1 (EIA-481-C)	
/W	Quadrant 2 (EIA-481-D/E)	

Glossary

Table 148. Abbreviations and Nomenclature

Abbreviation	Description
Index <i>n</i>	Denominates a clock input CLK_ <i>n</i> . Range: 0 to 1
Index <i>x</i>	Denominates a RF clock channel, clock and SYSREF outputs, clock frequency divider, delay circuits and the associated configuration bits. Range: R0, R1, R2, R3
Index <i>y</i>	Denominates a QCLK RF-PLL output and associated configuration bits. Range: R0, R1, R2, R3, R4, R5
Index <i>d</i>	Denominates a QCLK DPLL output and associated configuration bits. Range: D0, D1, D2, D3
Index <i>r</i>	Denominates a QREF RF-PLL SYSREF output and associated configuration bits. Range: R0, R1, R2, R3, R4, R5
V _{DD_V}	Denominates voltage supply pins. Range: VDD_DPLL0, VDD_DPLL1, VDD_GPIO, VDD_APLL, VDD_RFPLL, VDD_RFVCO, VDD_DCO1, VDD_INP, VDD_SPI, VDD_OSC, VDD_XO, VDD_SYNC
V _{DDO_V}	Denominates voltage supply pins. Range: VDDO_QREF, VDDO_D0, VDDO_D1, VDDO_D2, VDDO_D3, VDDO_R01, VDDO_R23, VDDO_R4, VDDO_R5, VDDO_QR, VDDO_REF
status_condition	Status conditions.
[...]	Index brackets describe a group associated with a logical function or a bank of outputs.
{...}	List of discrete values
Device clock	Clock generated from the RF-PLL to drive converters (ADC, DAC). For converters, the device clock is a master clock signal from which a device must generate its local clocks.
SYSREF	A periodic or continues, one-shot (strobe-type), or “gapped” periodic signal used to align the boundaries of local clocks in JESD204B/C subclass 1 devices. SYSREF output signals are synchronous with the device clock.
DPLL-0 with DCO-0, APLL-0	Functional unit of a digital PLL zero that contains a digitally controlled oscillator (DCO-0) and an analog PLL (APLL-0) for jitter attenuation and frequency conversion.
DPLL-1 with DCO-1, APLL-1	Functional unit of a digital PLL one that contains a digitally controlled oscillator (DCO-1) and an analog PLL (APLL-1) for jitter attenuation and frequency conversion.
APLL-2	Functional unit of an analog PLL 2, independently operating from other PLLs.
RF-PLL	Functional unit of an analog PLL for RF frequency generation, independently operating from other PLLs.
SYS-APLL	System analog PLL. Provides internal clock signals.
SYS-DPLL	System digital PLL.
1PPS	A 1Hz synchronization signal (one pulse per second)
FCW	Frequency control word
TDC	Time-to-Digital converter. Front-end of the DPLLs
PEC	Phase Error Compensation
DSM or ΔΣ	Delta-Sigma modulator
R/O	Read-only register bit
R/W	Register bit with read/write access
RW1C	Register bit with read/write access, bit is cleared (reset to 0) by writing a “1”. Used for latched status bits
W1AC	Register bit with write access and auto-clear

Errata

Table 149. Functional Errata

#	Parameter/Function	Description	Work-Around
D1	tSCO - Clock in to Data Out (Slave) tHD_PP - SDA Signal Data Hold Time	Violations to I3C specification - see footnotes in Table 143	None.
D2	I3C/I2C Protocol	After the device NACKs for any errors, the master should issue a stop and then do a start for continuing the transaction. A Repeat start after the NACK does not ACK for the continuing transactions.	Master needs to issue single START.
D3	I3C/I2C Protocol	RSTDAA CCC - The slave does not respond to I2C after RSTDAA CCC instruction was sent. I2C does not respond after issuing the 7E address.	Not supported.
D6	Hitless switching and switching between low frequency clocks (< 1MHz).	When using hitless switching, for low frequency clocks (< 960kHz), larger than expect phase transient may be seen at the clock outputs. Worse case maximum is < 2.5ns.	To meet < 1ns, use clocks > 960kHz. AC/DC specification updated to reflect.
D7	Reference switching between 1PPS clocks.	Reference switching (both normal and hitless) is not supported with 1PPS input clocks.	None.

Revision History

Revision Date	Description
May 18, 2021	<ul style="list-style-type: none"> ▪ Updated the following figures: <ul style="list-style-type: none"> – Figure 1 – Figure in Table 6 – Figure in Table 7 – Figure 13 – Figure 14
March 15, 2021	<ul style="list-style-type: none"> ▪ Corrected description of “Optimized for low phase noise” in Features and Features (Full List) ▪ Corrected several typos in Table 140
February 25, 2021	<ul style="list-style-type: none"> ▪ Updated the address offsets in Table 51
February 17, 2021	<ul style="list-style-type: none"> ▪ Clarified throughout document that operating temperature range is based on “board” temperature ▪ Clarified in all AC/DC Tables that 105oC is measured at case ▪ Corrected that APLL-0 VCO supports range of 2.45-2.58GHz ▪ Corrected default value for HITLESS_BW_SHIFT_DPLL0[4:0] and HITLESS_BW_SHIFT_DPLL1[4:0] ▪ Update Table 139 to add “Output Phase Change for Hitless Reference Switching” ▪ Added D6 and D7 to Erratum section ▪ Other minor text edits for clarification or to fix typos
January 21, 2021	Initial release.

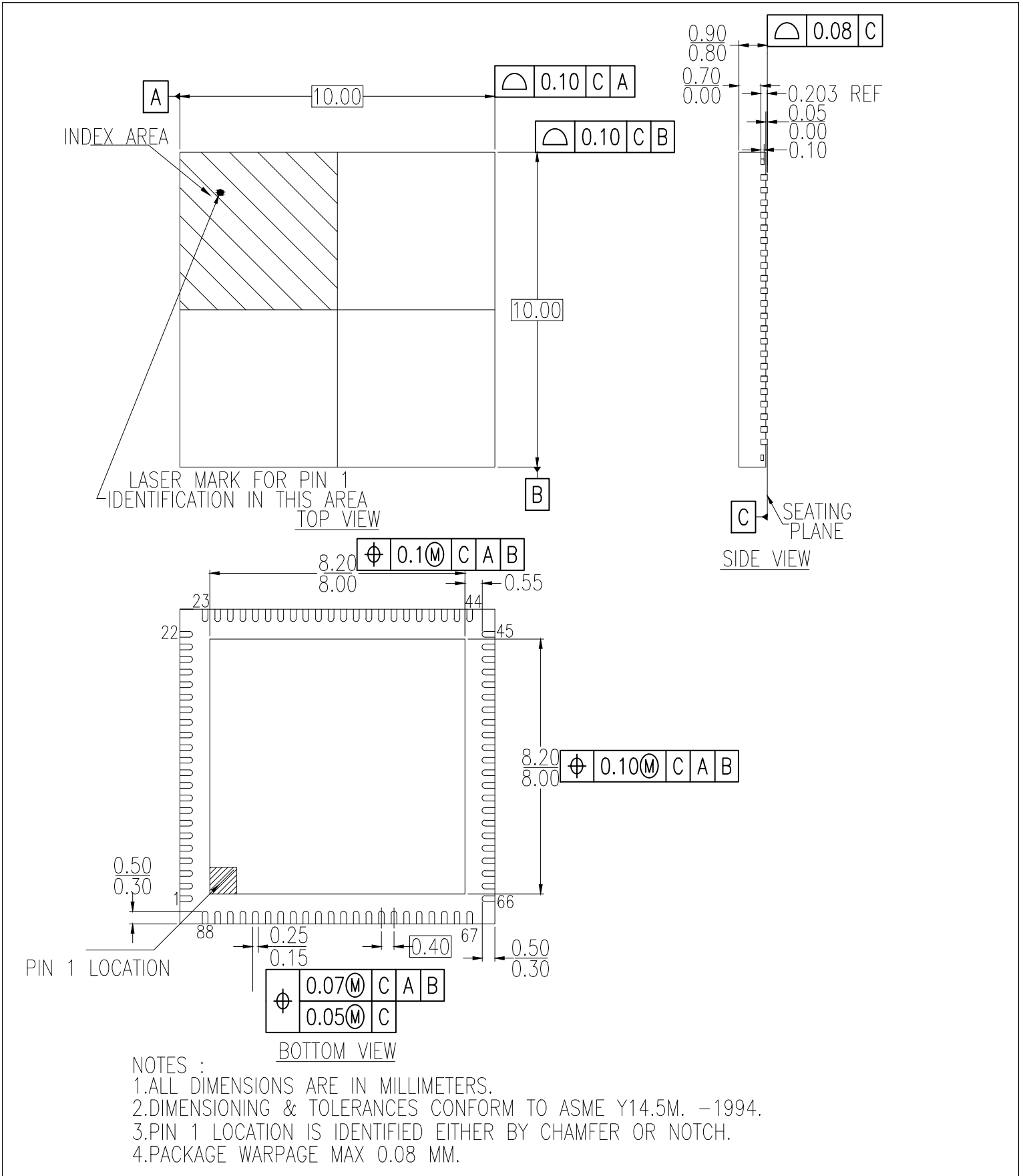

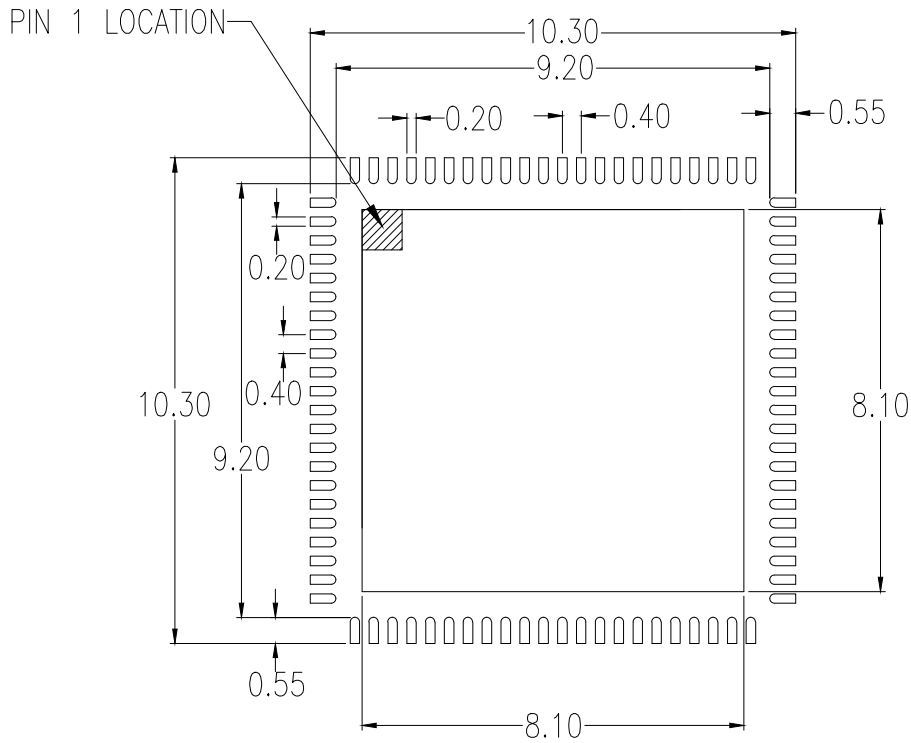

RECOMMENDED LAND PATTERN DIMENSION

NOTES:

1. ALL DIMENSIONS ARE IN MM. ANGLES IN DEGREES.
2. TOP DOWN VIEW. AS VIEWED ON PCB.
3. LAND PATTERN RECOMMENDATION PER IPC-7351B GENERIC REQUIREMENT FOR SURFACE MOUNT DESIGN AND LAND PATTERN.

Package Revision History		
Date Created	Rev No.	Description
March 8, 2018	Rev 02	Change QFN to VFQFPN, Change Pin 1 Identifier
Dec 4, 2017	Rev 01	New Format

IMPORTANT NOTICE AND DISCLAIMER

RENESAS ELECTRONICS CORPORATION AND ITS SUBSIDIARIES (“RENESAS”) PROVIDES TECHNICAL SPECIFICATIONS AND RELIABILITY DATA (INCLUDING DATASHEETS), DESIGN RESOURCES (INCLUDING REFERENCE DESIGNS), APPLICATION OR OTHER DESIGN ADVICE, WEB TOOLS, SAFETY INFORMATION, AND OTHER RESOURCES “AS IS” AND WITH ALL FAULTS, AND DISCLAIMS ALL WARRANTIES, EXPRESS OR IMPLIED, INCLUDING, WITHOUT LIMITATION, ANY IMPLIED WARRANTIES OF MERCHANTABILITY, FITNESS FOR A PARTICULAR PURPOSE, OR NON-INFRINGEMENT OF THIRD PARTY INTELLECTUAL PROPERTY RIGHTS.

These resources are intended for developers skilled in the art designing with Renesas products. You are solely responsible for (1) selecting the appropriate products for your application, (2) designing, validating, and testing your application, and (3) ensuring your application meets applicable standards, and any other safety, security, or other requirements. These resources are subject to change without notice. Renesas grants you permission to use these resources only for development of an application that uses Renesas products. Other reproduction or use of these resources is strictly prohibited. No license is granted to any other Renesas intellectual property or to any third party intellectual property. Renesas disclaims responsibility for, and you will fully indemnify Renesas and its representatives against, any claims, damages, costs, losses, or liabilities arising out of your use of these resources. Renesas' products are provided only subject to Renesas' Terms and Conditions of Sale or other applicable terms agreed to in writing. No use of any Renesas resources expands or otherwise alters any applicable warranties or warranty disclaimers for these products.

(Rev.1.0 Mar 2020)

Corporate Headquarters

TOYOSU FORESIA, 3-2-24 Toyosu,
Koto-ku, Tokyo 135-0061, Japan
www.renesas.com

Contact Information

For further information on a product, technology, the most up-to-date version of a document, or your nearest sales office, please visit:
www.renesas.com/contact/

Trademarks

Renesas and the Renesas logo are trademarks of Renesas Electronics Corporation. All trademarks and registered trademarks are the property of their respective owners.

X-ON Electronics

Largest Supplier of Electrical and Electronic Components

Click to view similar products for [Clock Generators & Support Products](#) category:

Click to view products by [Renesas](#) manufacturer:

Other Similar products are found below :

[CV183-2TPAG](#) [950810CGLF](#) [9DBV0741AKILF](#) [9VRS4420DKLF](#) [CY25404ZXI226](#) [CY25422SXI-004](#) [MPC9893AE](#) [NB3H5150-01MNTXG](#) [PL602-20-K52TC](#) [ICS557GI-03LF](#) [PI6LC48P0101LIE](#) [82P33814ANLG](#) [840021AGLF](#) [ZL30244LFG7](#) [PI6LC48C21LE](#) [ZL30245LFG7](#) [PI6LC48P0405LIE](#) [PI6LC48P03LE](#) [MAX24505EXG+](#) [ZL30163GDG2](#) [5L1503L-000NVGI8](#) [ZL30673LFG7](#) [MAX24188ETK2](#) [ZL30152GGG2](#) [5L1503-000NVGI8](#) [PI6C557-01BZHIEX](#) [PI6LC48C21LIE](#) [CY2542QC002](#) [5P35023-106NLGI](#) [5X1503L-000NLGI8](#) [ZL30121GGG2V2](#) [ZL30282LDG1](#) [ZL30102QDG1](#) [ZL30159GGG2](#) [DS1070K](#) [ZL30145GGG2](#) [ZL30312GKG2](#) [MAX24405EXG2](#) [ZL30237GGG2](#) [SY100EL34LZG](#) [9FGV1002BQ506LTGI](#) [AD9518-4ABCPZ](#) [MX852BB0030](#) [PI6LC4840ZHE](#) [AD9516-4BCPZ-REEL7](#) [AD9516-0BCPZ-REEL7](#) [AD9574BCPZ-REEL7](#) [PL602-21TC-R](#) [ZL30105QDG1](#) [ZL30100QDG1](#)