

High Performance Communication Buffer

General Description

The **ICS91309** is a high performance, low skew, low jitter zero delay buffer. It uses a phase lock loop (PLL) technology to align, in both phase and frequency, the REF input with the CLKOUT signal. It is designed to distribute high speed clocks in communication systems operating at speeds from 10 to 133 MHz.

The **ICS91309** provides synchronization between the input and output. The synchronization is established via CLKOUT feed back to the input of the PLL. Since the skew between the input and output is less than +/- 350 pS, the part acts as a zero delay buffer.

ICS91309 has two banks of four outputs controlled by two address lines. Depending on the selected address line, bank B or both banks can be put in a tri-state mode. In this mode, the PLL is still running and only the output buffers are put in a high impedance mode. The test mode shuts off the PLL and connects the input directly to the output buffers (see table below for functionality).

ICS91309 comes in a 16-pin 150 mil SOIC, SSOP or 4.40mm TSSOP package. In the absence of REF input, the device will enter a powerdown mode. In this mode, the PLL is turned off and the output buffers are pulled low. Power down mode provides the lowest power consumption for a standby condition.

Block Diagram

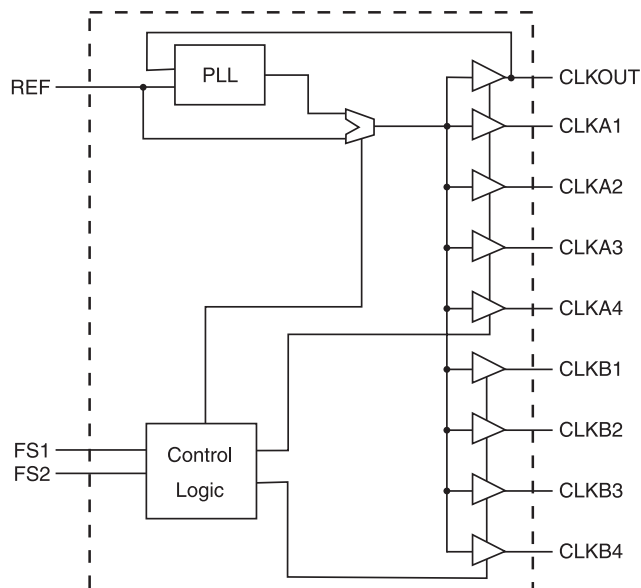

Features

- Zero input - output delay
- Frequency range 10 - 133 MHz (3.3V)
- 5V tolerant input REF
- High loop filter bandwidth ideal for Spread Spectrum applications.
- Less than 125 ps cycle to cycle Jitter
- Skew controlled outputs
- Available in 16 pin, 150 mil SSOP, SOIC & 4.40mm TSSOP packages
- Skew: Group-to-Group: <215 ps
- Skew within Group: <100 ps
- Commercial temperature range: 0°C to +70°C

Pin Configuration

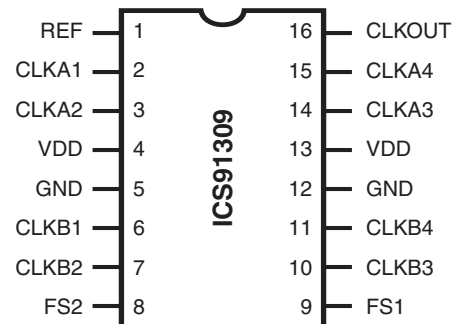

16 pin SSOP, SOIC & TSSOP

Functionality

FS2	FS1	CLKA(1:4)	CLKB(1:4)	CLKOUT	Ouput Source	PLL Shutdown
0	0	Tristate	Tristate	Driven	PLL	N
0	1	Driven	Tristate	Driven	PLL	N
1	0	PLL Bypass Mode	PLL Bypass Mode	PLL Bypass Mode	REF	Y
1	1	Driven	Driven	Driven	PLL	N

Pin Descriptions

PIN #	PIN NAME	PIN TYPE	DESCRIPTION
1	REF ¹	IN	Input reference frequency, 5V tolerant input
2	CLKA1 ²	OUT	Buffered clock output, Bank A
3	CLKA2 ²	OUT	Buffered clock output, Bank A
4, 13	VDD	PWR	Power Supply
5, 12	GND	PWR	Ground
6	CLKB1 ²	OUT	Buffered clock output, Bank B
7	CLKB2 ²	OUT	Buffered clock output, Bank B
8	FS2 ³	IN	Function select input, bit 2
9	FS1 ³	IN	Function select input, bit 1
10	CLKB3 ²	OUT	Buffered clock output, Bank B
11	CLKB4 ²	OUT	Buffered clock output, Bank B
14	CLKA3 ²	OUT	Buffered clock output, Bank A
15	CLKA4 ²	OUT	Buffered clock output, Bank A
16	CLKOUT ²	OUT	Buffered clock output, internal feedback

Notes:

1. Weak pull-down
2. Weak pull-down on all outputs
3. Weak pull-ups on these inputs

Absolute Maximum Ratings

Supply Voltage	7.0 V
Logic Inputs (Except REF)	GND -0.5 V to $V_{DD} + 0.5$ V
Logic Input REF	GND -0.5 V to GND + 5.5 V
Ambient Operating Temperature	0°C to +70°C
Storage Temperature	-65°C to +150°C

Stresses above those listed under *Absolute Maximum Ratings* may cause permanent damage to the device. These ratings are stress specifications only and functional operation of the device at these or any other conditions above those listed in the operational sections of the specifications is not implied. Exposure to absolute maximum rating conditions for extended periods may affect product reliability.

Electrical Characteristics - Input & Supply

$T_A = 0 - 70^\circ\text{C}$; Supply Voltage $V_{DD} = 3.3$ V +/-10%

PARAMETER	SYMBOL	CONDITIONS	MIN	TYP	MAX	UNITS
Input High Voltage	V_{IH}		2			V
Input Low Voltage	V_{IL}				0.8	V
Input High Current	I_{IH}	$V_{IN} = V_{DD}$		0.1	100	uA
Input Low Current	I_{IL}	$V_{IN} = 0$ V		19	50	uA
Output High Voltage	V_{OH}	$I_{OH} = -12$ mA	2.4			V
Output Low Voltage	V_{OL}	$I_{OL} = 12$ mA			0.4	V
Operating Supply Current	I_{DD}	Outputs Unloaded; REF = 66 MHz		30	45	mA
Powerdown Current	I_{DD}	REF = 0 Mhz		0.3	12	uA
Input Frequency	F_i		10		133	MHz
Input Capacitance ¹	C_{IN}				5	pF

NOTES:

1. Guaranteed by design and characterization, not 100% tested in production.

Electrical Characteristics - Outputs

$T_A = 0 - 70^\circ\text{C}$; $V_{DD} = 3.3 \text{ V} \pm 10\%$; $C_L = 30 \text{ pF}$ (unless otherwise specified)

PARAMETER	SYMBOL	CONDITIONS	MIN	TYP	MAX	UNITS
Output High Voltage	V_{OH}	$I_{OH} = -12 \text{ mA}$	2.4			V
Output Low Voltage	V_{OL}	$I_{OL} = 12 \text{ mA}$			0.4	V
Rise Time ¹	t_r	Measure between 0.8 V and 2.0 V		1.2	1.5	ns
Fall Time ¹	t_f	Measure between 2.0 V and 0.8 V		1.2	1.5	ns
PLL Lock Time ¹	T_{LOCK}	Stable V_{DD} , valid clock on REF			1	mS
Output Frequency	f_i	$C_L = 30 \text{ pF}$	10		100	MHz
	f_i	$C_L = 10 \text{ pF}$	10		133	MHz
Duty Cycle ¹	Dt1	Measured at 1.4 V, $F_{out} = 66.7 \text{ MHz}$	40	50	60	%
	Dt2	Measured at $V_{DD}/2$, $F_{out} < 50.0 \text{ MHz}$	45	50	55	%
Jitter, Cycle-to-cycle ¹	$t_{j\text{cyc-cyc}}$	Measured at 66.7 MHz, loaded outputs			125	ps
Jitter, Absolute ¹	Tjabs	10,000 cycles, $C_L = 30 \text{ pF}$	-100	70	100	ps
Jitter, 1-Sigma ¹	Tj1s	10,000 cycles, $C_L = 30 \text{ pF}$		14	30	ps
Skew, Group-to-Group ¹	Tsk	Measured at 1.4 V			215	ps
Skew, Output-to-Output ¹	Tsk	Measured at 1.4 V, within a group			100	ps
Skew, Device-to-Device ¹	Tdsk-Tdsk	Measured at $V_{DD}/2$, on CLKOUT pins			700	ps
Delay, Input-to-Output ¹	Dr1	Measured at 1.4 V			700	ps

Notes:

1. Guaranteed by design and characterization, not 100% tested in production.

Output to Output Skew

The skew between CLKOUT and the CLKA/B outputs is not dynamically adjusted by the PLL. Since CLKOUT is one of the inputs to the PLL, zero phase difference is maintained from REF to CLKOUT. If all outputs are equally loaded, zero phase difference will be maintained from REF to all outputs.

If applications requiring zero output-to-output skew, all the outputs must be equally loaded.

If the CLKA/B outputs are less loaded than CLKOUT, CLKA/B outputs will lead it; and if the CLKA/B is more loaded than CLKOUT, CLKA/B will lag the CLKOUT.

Since the CLKOUT and the CLKA/B outputs are identical, they all start at the same time, but different loads cause them to have different rise times and different times crossing the measurement thresholds.

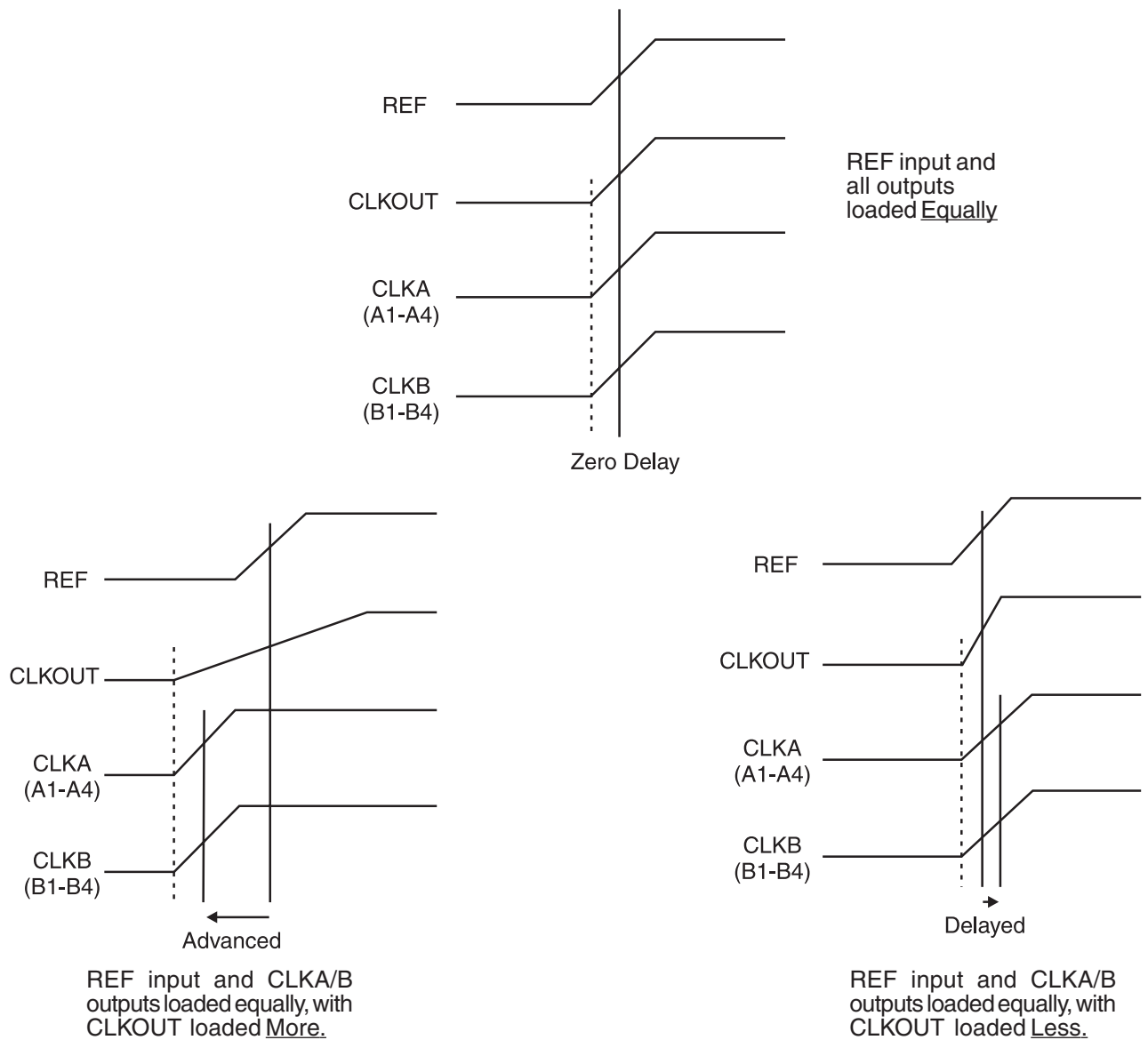

Application Suggestion:

ICS91309 is a mixed analog/digital product. The analog portion of the PLL is very sensitive to any random noise generated by charging or discharging of internal or external capacitor on the power supply pins. This type of noise will cause excess jitter to the outputs of **ICS91309**. Below is a recommended layout to alleviate any addition noise. For additional information on FT. layout, please refer to our AN07. The 0.1 uF capacitors should be connected as close as possible to power pins (4 & 13). An Isolated power plane with a 2.2 uF capacitor to ground will enhance the power line stability.

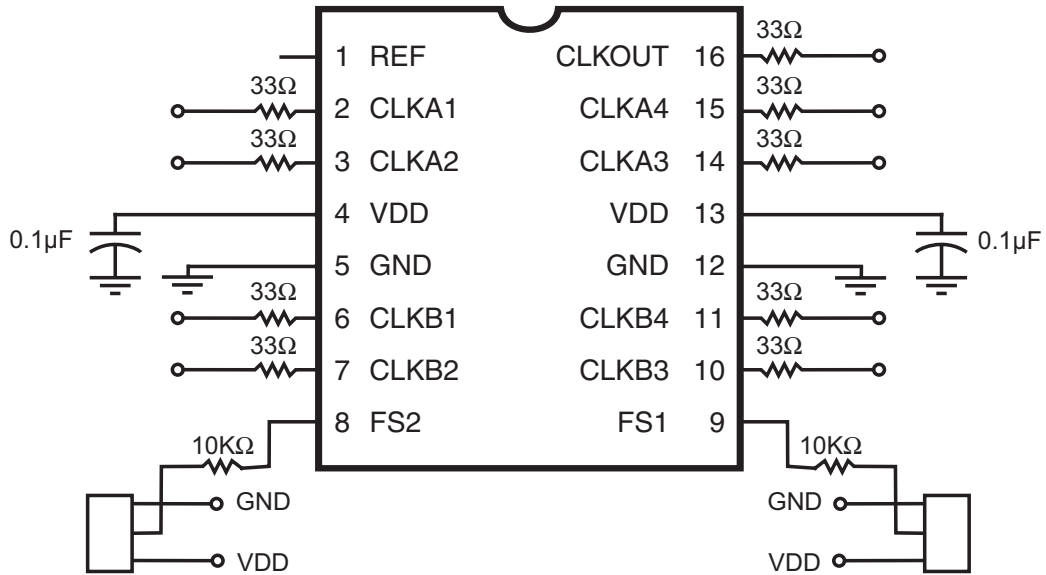

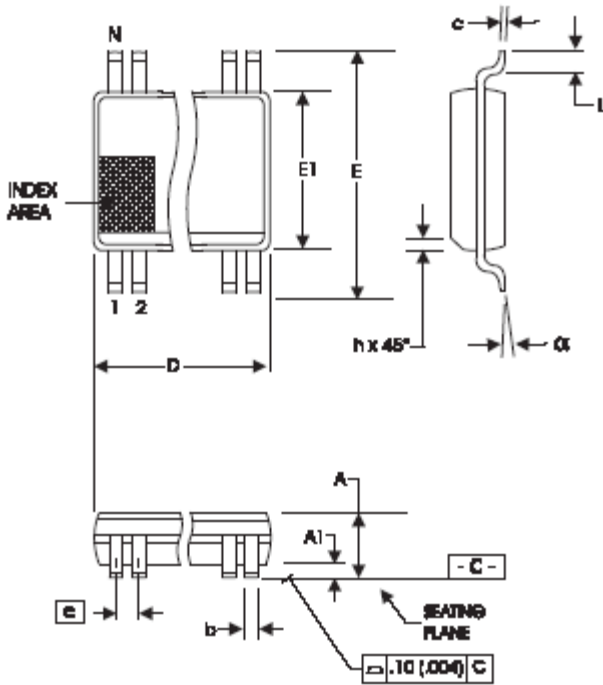

SYMBOL	In Millimeters COMMON DIMENSIONS		In Inches COMMON DIMENSIONS	
	MIN	MAX	MIN	MAX
A	1.35	1.75	.053	.069
A1	0.1	0.25	.0040	.010
A2	—	1.50	—	.059
b	0.20	0.30	.008	.012
c	0.18	0.25	.007	.010
D	SEE VARIATIONS		SEE VARIATIONS	
E	5.80	6.20	.228	.244
E1	3.80	4.00	.150	.157
e	0.635 BASIC		0.025 BASIC	
L	0.40	1.27	.016	.050
N	SEE VARIATIONS		SEE VARIATIONS	
α	0°	8°	0°	8°
ZD	SEE VARIATIONS		SEE VARIATIONS	

VARIATIONS

N	D mm.		ZD	D (inch)		ZD
	MIN	MAX	(Ref)	MIN	MAX	(Ref)
16	4.80	5.00	0.23	.189	.197	.009

JEDEC MO-137
DOC# 10-0032

6/1/00
REV B

Ordering Information

91309yFLFT

Example:

XXXX y F LFT

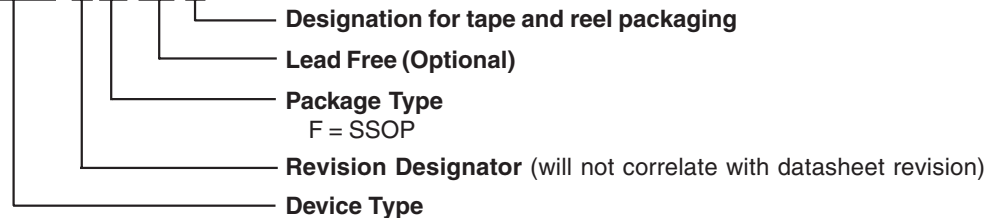

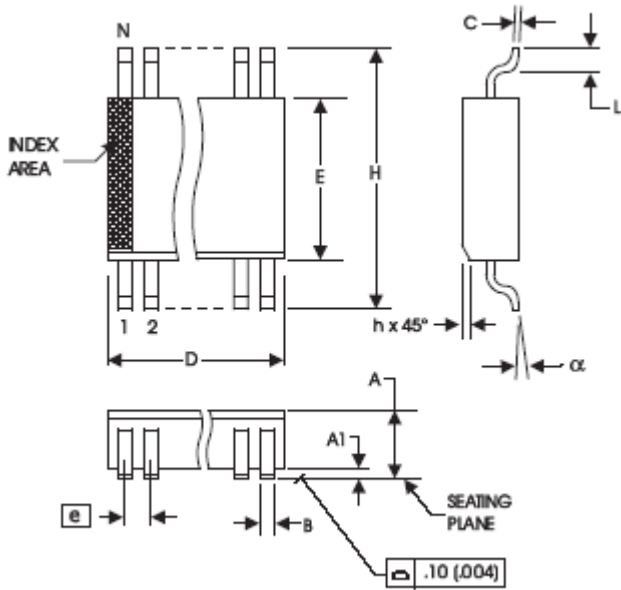

150 mil (Narrow Body) SOIC

SYMBOL	In Millimeters COMMON DIMENSIONS		In Inches COMMON DIMENSIONS	
	MIN	MAX	MIN	MAX
A	1.35	1.75	.0532	.0688
A1	0.10	0.25	.0040	.0098
B	0.33	0.51	.013	.020
C	0.19	0.25	.0075	.0098
D	SEE VARIATIONS		SEE VARIATIONS	
E	3.80	4.0	.1497	.1574
e	1.27 BASIC		0.050 BASIC	
H	5.80	6.20	.2284	.2440
h	0.25	0.50	.010	.020
L	0.40	1.27	.016	.050
N	SEE VARIATIONS		SEE VARIATIONS	
α	0°	8°	0°	8°

VARIATIONS

N	D mm.		D (inch)	
	MIN	MAX	MIN	MAX
16	9.80	10.00	.3859	.3937

Ordering Information

91309yMLFT

Example:

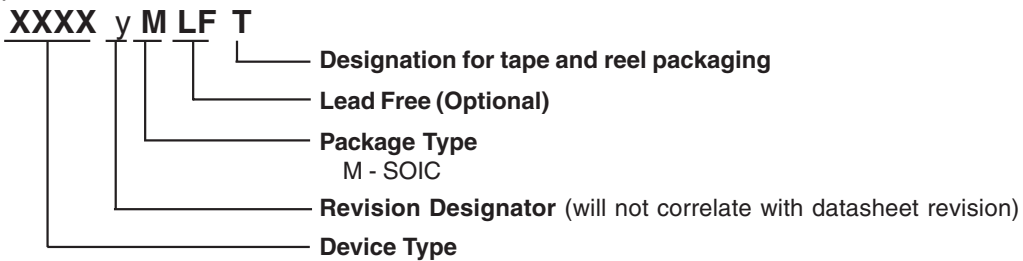

**4.40 mm. Body, 0.65 mm. Pitch TSSOP
(173 mil) (25.6 mil)**

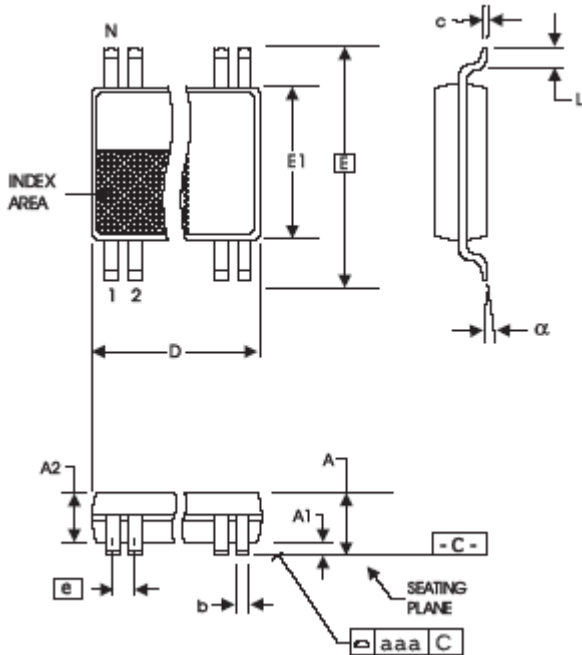

SYMBOL	In Millimeters		In Inches	
	COMMON DIMENSIONS	COMMON DIMENSIONS	COMMON DIMENSIONS	COMMON DIMENSIONS
A	--	1.20	--	.047
A1	0.05	0.15	.002	.006
A2	0.80	1.05	.032	.041
b	0.19	0.30	.007	.012
c	0.09	0.20	.0035	.008
D	SEE VARIATIONS		SEE VARIATIONS	
E	6.40 BASIC		0.252 BASIC	
E1	4.30	4.50	.169	.177
e	0.65 BASIC		0.0256 BASIC	
L	0.45	0.75	.018	.030
N	SEE VARIATIONS		SEE VARIATIONS	
alpha	0°	8°	0°	8°
aaa	--	0.10	--	.004

VARIATIONS

N	D mm.		D (inch)	
	MIN	MAX	MIN	MAX
16	4.90	5.10	.193	.201

Reference Doc.: JEDEC Publication 95, MO-153
10-0035

Ordering Information

91309yGLFT

Example:

XXXX y G LFT

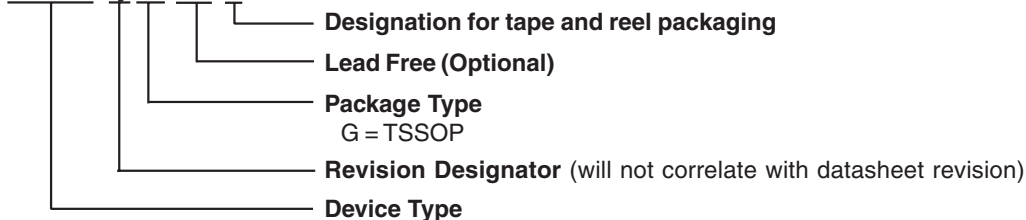

Revision History

Rev.	Issue Date	Description	Page #
H	12/9/2008	Removed ICS prefix from ordering information	7-9

IMPORTANT NOTICE AND DISCLAIMER

RENESAS ELECTRONICS CORPORATION AND ITS SUBSIDIARIES (“RENESAS”) PROVIDES TECHNICAL SPECIFICATIONS AND RELIABILITY DATA (INCLUDING DATASHEETS), DESIGN RESOURCES (INCLUDING REFERENCE DESIGNS), APPLICATION OR OTHER DESIGN ADVICE, WEB TOOLS, SAFETY INFORMATION, AND OTHER RESOURCES “AS IS” AND WITH ALL FAULTS, AND DISCLAIMS ALL WARRANTIES, EXPRESS OR IMPLIED, INCLUDING, WITHOUT LIMITATION, ANY IMPLIED WARRANTIES OF MERCHANTABILITY, FITNESS FOR A PARTICULAR PURPOSE, OR NON-INFRINGEMENT OF THIRD PARTY INTELLECTUAL PROPERTY RIGHTS.

These resources are intended for developers skilled in the art designing with Renesas products. You are solely responsible for (1) selecting the appropriate products for your application, (2) designing, validating, and testing your application, and (3) ensuring your application meets applicable standards, and any other safety, security, or other requirements. These resources are subject to change without notice. Renesas grants you permission to use these resources only for development of an application that uses Renesas products. Other reproduction or use of these resources is strictly prohibited. No license is granted to any other Renesas intellectual property or to any third party intellectual property. Renesas disclaims responsibility for, and you will fully indemnify Renesas and its representatives against, any claims, damages, costs, losses, or liabilities arising out of your use of these resources. Renesas' products are provided only subject to Renesas' Terms and Conditions of Sale or other applicable terms agreed to in writing. No use of any Renesas resources expands or otherwise alters any applicable warranties or warranty disclaimers for these products.

(Rev.1.0 Mar 2020)

Corporate Headquarters

TOYOSU FORESIA, 3-2-24 Toyosu,
Koto-ku, Tokyo 135-0061, Japan
www.renesas.com

Contact Information

For further information on a product, technology, the most up-to-date version of a document, or your nearest sales office, please visit:
www.renesas.com/contact/

Trademarks

Renesas and the Renesas logo are trademarks of Renesas Electronics Corporation. All trademarks and registered trademarks are the property of their respective owners.

X-ON Electronics

Largest Supplier of Electrical and Electronic Components

Click to view similar products for [Clock Buffer](#) category:

Click to view products by [Renesas](#) manufacturer:

Other Similar products are found below :

[MPC962309EJ-1H](#) [NB4N121KMNG](#) [IDT49FCT805ASO](#) [MK2308S-1HILF](#) [PL133-27GI-R](#) [NB3L02FCT2G](#) [NB3L03FCT2G](#)
[ZL40203LDG1](#) [ZL40200LDG1](#) [ZL40205LDG1](#) [9FG1200DF-1LF](#) [9FG1001BGLF](#) [ZL40202LDG1](#) [PI49FCT20802QE](#) [SL2305SC-1T](#)
[PI6C4931502-04LIE](#) [NB7L1008MNG](#) [NB7L14MN1G](#) [PI49FCT20807QE](#) [PI6C4931502-04LIEX](#) [ZL80002QAB1](#) [PI6C4931504-04LIEX](#)
[PI6C10806BLEX](#) [ZL40226LDG1](#) [ZL40219LDG1](#) [8T73S208B-01NLGI](#) [SY75578LMG](#) [PI49FCT32805QEX](#) [PL133-27GC-R](#)
[CDCV304PWG4](#) [MC10LVEP11DG](#) [MC10EP11DTG](#) [MC100LVEP11DG](#) [MC100E111FNG](#) [MC100EP11DTG](#) [NB6N11SMNG](#)
[NB7L14MMNG](#) [NB3N2304NZDTR2G](#) [NB6L11MMNG](#) [NB6L14MMNR2G](#) [NB6L611MNG](#) [PL123-02NGI-R](#) [NB3N111KMNR4G](#)
[ADCLK944BCPZ-R7](#) [ZL40217LDG1](#) [NB7LQ572MNG](#) [HMC940LC4BTR](#) [ADCLK946BCPZ-REEL7](#) [ADCLK946BCPZ](#)
[ADCLK846BCPZ-REEL7](#)