

Description

The 9DBV0831 is a member of Renesas' SOC-Friendly 1.8V Very-Low-Power (VLP) PCIe family. It can also be used for 50M or 125M Ethernet Applications via software frequency selection. The device has 8 output enables for clock management, and 3 selectable SMBus addresses.

Recommended Application

1.8V PCIe Gen1–5 Zero Delay/Fanout Buffer (ZDB/FOB)

Output Features

- Eight 1–200MHz Low-Power (LP) HCSL DIF pairs with $Z_o = 33\Omega$

Key Specifications

- DIF cycle-to-cycle jitter < 50ps
- DIF output-to-output skew < 50ps
- PCIe Gen5 CC additive phase jitter < 40fs RMS
- 12kHz–20MHz additive phase jitter = 156fs RMS at 156.25M (typical)

Features/Benefits

- LP-HCSL outputs save 16 resistors; minimal board space and BOM cost
- 62mW typical power consumption in PLL mode; minimal power consumption
- Spread Spectrum (SS) compatible; allows use of SS for EMI reduction
- OE# pins; support DIF power management
- HCSL compatible differential input; can be driven by common clock sources
- Programmable Slew rate for each output; allows tuning for various line lengths
- Programmable output amplitude; allows tuning for various application environments
- Pin/software selectable PLL bandwidth and PLL Bypass; minimize phase jitter for each application
- Outputs blocked until PLL is locked; clean system start-up
- Software selectable 50MHz or 125MHz PLL operation; useful for Ethernet applications
- Configuration can be accomplished with strapping pins; SMBus interface not required for device control
- 3.3V tolerant SMBus interface works with legacy controllers
- Space saving 6 x 6mm 48-VFQFPN; minimal board space
- Selectable SMBus addresses; multiple devices can easily share an SMBus segment

Block Diagram

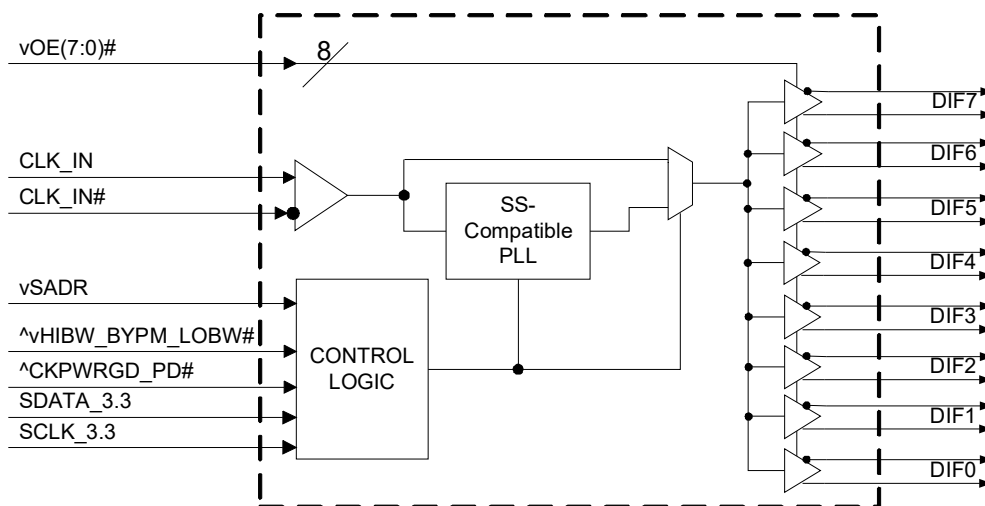

Pin Configuration

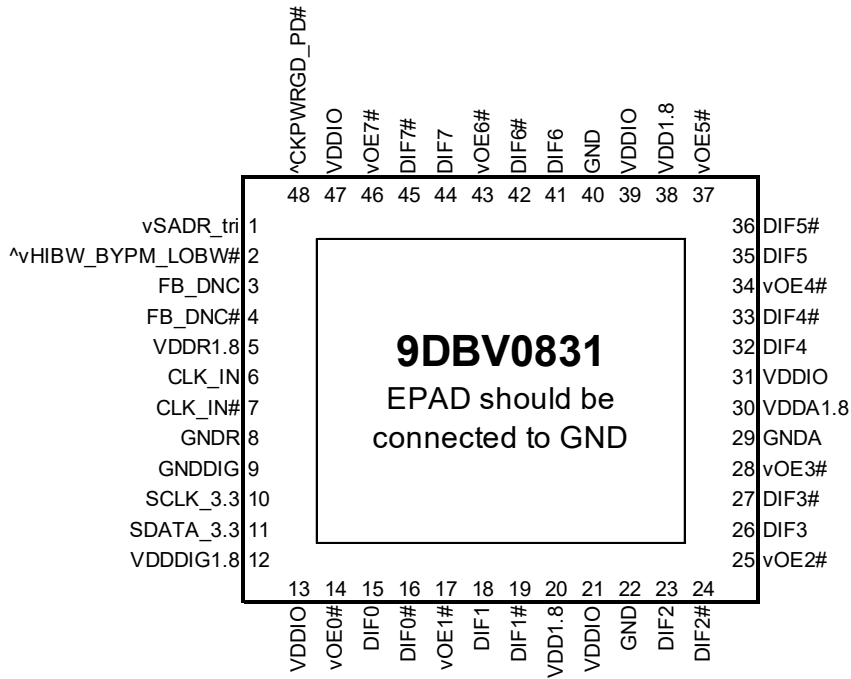

48-pin VFQFPN, 6x6 mm, 0.4mm pitch

- ^v prefix indicates internal 120KOhm pull up *AND* pull down resistor (biased to VDD/2)
- v prefix indicates internal 120KOhm pull down resistor
- ^ prefix indicates internal 120KOhm pull up resistor

SMBus Address Selection Table

	SADR	Address	+ Read/Write bit
State of SADR on first application of CKPWRGD_PD#	0	1101011	x
	M	1101100	x
	1	1101101	x

Power Management Table

CKPWRGD_PD#	CLK_IN	SMBus OEx bit	OEx# Pin	DIFx		PLL
				True O/P	Comp. O/P	
0	X	X	X	Low	Low	Off
1	Running	0	X	Low	Low	On ¹
1	Running	1	0	Running	Running	On ¹
1	Running	1	1	Low	Low	On ¹

1. If Bypass mode is selected, the PLL will be off, and outputs will be running.

Power Connections

Pin Number			Description
VDD	VDDIO	GND	
5		8	Input receiver analog
12		9	Digital Power
20, 31, 38	13, 21, 31, 39, 47	22, 29, 40	DIF outputs
30		29	PLL Analog

Frequency Select Table

FSEL Byte3 [4:3]	CLK_IN (MHz)	DIFx (MHz)
00 (Default)	100.00	CLK_IN
01	50.00	CLK_IN
10	125.00	CLK_IN
11	Reserved	Reserved

PLL Operating Mode

HiBW_BypM_LoBW#	MODE	Byte1 [7:6] Readback	Byte1 [4:3] Control
0	PLL Lo BW	00	00
M	Bypass	01	01
1	PLL Hi BW	11	11

Pin Descriptions

PIN #	PIN NAME	TYPE	DESCRIPTION
1	vSADR_tri	LATCHED IN	Tri-level latch to select SMBus Address. See SMBus Address Selection Table.
2	^vHIBW_BYPM_LOBW#	LATCHED IN	Trilevel input to select High BW, Bypass or Low BW mode. See PLL Operating Mode Table for Details.
3	FB_DNC	DNC	True clock of differential feedback. The feedback output and feedback input are connected internally on this pin. Do not connect anything to this pin.
4	FB_DNC#	DNC	Complement clock of differential feedback. The feedback output and feedback input are connected internally on this pin. Do not connect anything to this pin.
5	VDDR1.8	PWR	1.8V power for differential input clock (receiver). This VDD should be treated as an Analog power rail and filtered appropriately.
6	CLK_IN	IN	True Input for differential reference clock.
7	CLK_IN#	IN	Complementary Input for differential reference clock.
8	GNDR	GND	Analog Ground pin for the differential input (receiver)
9	GNDDIG	GND	Ground pin for digital circuitry
10	SCLK_3.3	IN	Clock pin of SMBus circuitry, 3.3V tolerant.
11	SDATA_3.3	I/O	Data pin for SMBus circuitry, 3.3V tolerant.
12	VDDDIG1.8	PWR	1.8V digital power (dirty power)
13	VDDIO	PWR	Power supply for differential outputs
14	vOE0#	IN	Active low input for enabling DIF pair 0. This pin has an internal pull-down. 1 =disable outputs, 0 = enable outputs
15	DIF0	OUT	Differential true clock output
16	DIF0#	OUT	Differential Complementary clock output
17	vOE1#	IN	Active low input for enabling DIF pair 1. This pin has an internal pull-down. 1 =disable outputs, 0 = enable outputs
18	DIF1	OUT	Differential true clock output
19	DIF1#	OUT	Differential Complementary clock output
20	VDD1.8	PWR	Power supply, nominal 1.8V
21	VDDIO	PWR	Power supply for differential outputs
22	GND	GND	Ground pin.
23	DIF2	OUT	Differential true clock output
24	DIF2#	OUT	Differential Complementary clock output
25	vOE2#	IN	Active low input for enabling DIF pair 2. This pin has an internal pull-down. 1 =disable outputs, 0 = enable outputs
26	DIF3	OUT	Differential true clock output
27	DIF3#	OUT	Differential Complementary clock output
28	vOE3#	IN	Active low input for enabling DIF pair 3. This pin has an internal pull-down. 1 =disable outputs, 0 = enable outputs
29	GNDA	GND	Ground pin for the PLL core.
30	VDDA1.8	PWR	1.8V power for the PLL core.
31	VDDIO	PWR	Power supply for differential outputs
32	DIF4	OUT	Differential true clock output
33	DIF4#	OUT	Differential Complementary clock output
34	vOE4#	IN	Active low input for enabling DIF pair 4. This pin has an internal pull-down. 1 =disable outputs, 0 = enable outputs
35	DIF5	OUT	Differential true clock output
36	DIF5#	OUT	Differential Complementary clock output
37	vOE5#	IN	Active low input for enabling DIF pair 5. This pin has an internal pull-down. 1 =disable outputs, 0 = enable outputs
38	VDD1.8	PWR	Power supply, nominal 1.8V

Pin Descriptions (cont.)

PIN #	PIN NAME	TYPE	DESCRIPTION
39	VDDIO	PWR	Power supply for differential outputs
40	GND	GND	Ground pin.
41	DIF6	OUT	Differential true clock output
42	DIF6#	OUT	Differential Complementary clock output
43	vOE6#	IN	Active low input for enabling DIF pair 6. This pin has an internal pull-down. 1 =disable outputs, 0 = enable outputs
44	DIF7	OUT	Differential true clock output
45	DIF7#	OUT	Differential Complementary clock output
46	vOE7#	IN	Active low input for enabling DIF pair 7. This pin has an internal pull-down. 1 =disable outputs, 0 = enable outputs
47	VDDIO	PWR	Power supply for differential outputs
48	^CKPWRGD_PD#	IN	Input notifies device to sample latched inputs and start up on first high assertion. Low enters Power Down Mode, subsequent high assertions exit Power Down Mode. This pin has internal pull-up resistor.
49	EPAD	GND	Connect to Ground

Test Loads

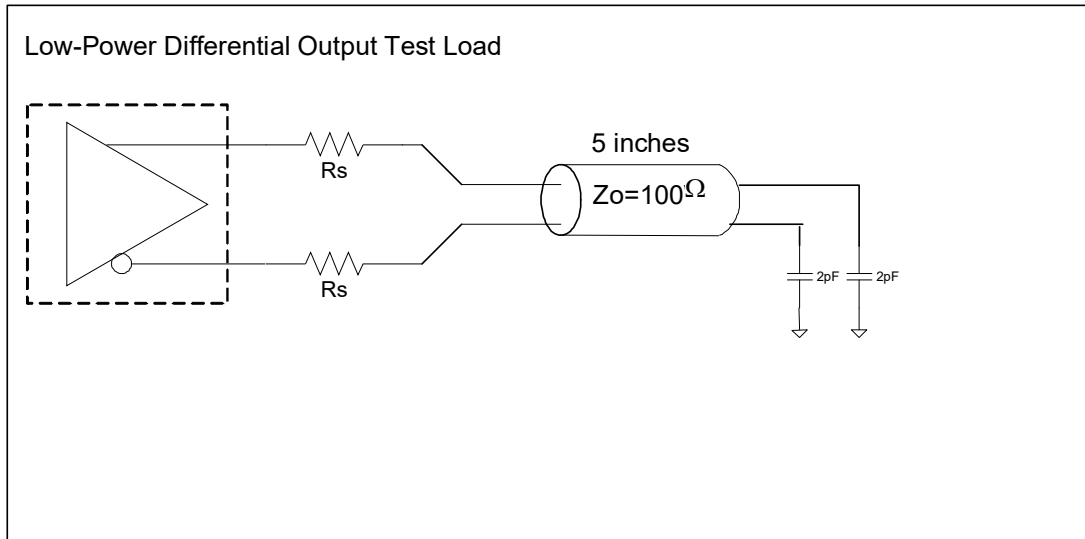

Alternate Differential Output Terminations

Rs	Zo	Units
33	100	Ohms
27	85	

Driving LVDS

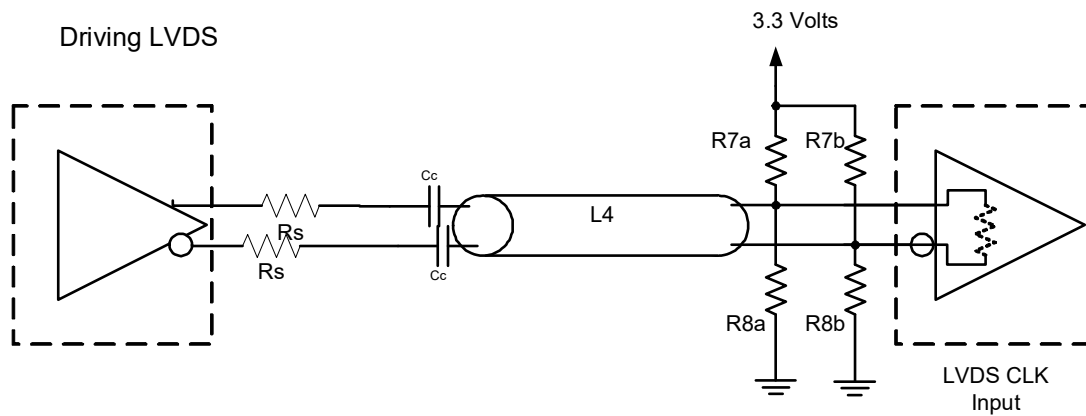

Driving LVDS inputs with the 9DBV0831

Component	Value		Note
	Receiver has termination	Receiver does not have termination	
R7a, R7b	10K ohm	140 ohm	
R8a, R8b	5.6K ohm	75 ohm	
Cc	0.1 uF	0.1 uF	
Vcm	1.2 volts	1.2 volts	

Absolute Maximum Ratings

Stresses above the ratings listed below can cause permanent damage to the 9DBV0831. These ratings, which are standard values for Renesas commercially rated parts, are stress ratings only. Functional operation of the device at these or any other conditions above those indicated in the operational sections of the specifications is not implied. Exposure to absolute maximum rating conditions for extended periods can affect product reliability. Electrical parameters are guaranteed only over the recommended operating temperature range.

PARAMETER	SYMBOL	CONDITIONS	MIN	TYP	MAX	UNITS	NOTES
Supply Voltage	VDDx		-0.5		2.5	V	1,2
Input Voltage	V _{IN}		-0.5		V _{DD} +0.5	V	1,3
Input High Voltage, SMBus	V _{IHSMB}	SMBus clock and data pins			3.6	V	1
Storage Temperature	T _s		-65		150	°C	1
Junction Temperature	T _j				125	°C	1
Input ESD protection	ESD prot	Human Body Model	2000			V	1

¹Guaranteed by design and characterization, not 100% tested in production.

²Operation under these conditions is neither implied nor guaranteed.

³Not to exceed 2.5V.

Electrical Characteristics–Clock Input Parameters

T_A = T_{AMB}, Supply Voltages per normal operation conditions, See Test Loads for Loading Conditions

PARAMETER	SYMBOL	CONDITIONS	MIN	TYP	MAX	UNITS	NOTES
Input Common Mode Voltage - DIF_IN	V _{COM}	Common Mode Input Voltage	200		725	mV	1
Input Swing - DIF_IN	V _{SWING}	Differential value	300		1450	mV	1
Input Slew Rate - DIF_IN	dV/dt	Measured differentially	0.4		8	V/ns	1,2
Input Leakage Current	I _{IN}	V _{IN} = V _{DD} , V _{IN} = GND	-5		5	uA	
Input Duty Cycle	d _{tin}	Measurement from differential waveform	45	50	55	%	1
Input Jitter - Cycle to Cycle	J _{DIFIN}	Differential Measurement	0		150	ps	1

¹Guaranteed by design and characterization, not 100% tested in production.

²Slew rate measured through +/-75mV window centered around differential zero.

Electrical Characteristics–Input/Supply/Common Parameters–Normal Operating Conditions

TA = T_{AMB}, Supply Voltages per normal operation conditions, See Test Loads for Loading Conditions

PARAMETER	SYMBOL	CONDITIONS	MIN	TYP	MAX	UNITS	NOTES
Supply Voltage	VDDx	Supply voltage for core and analog	1.7	1.8	1.9	V	
Output Supply Voltage	VDDIO	Supply voltage for Low Power HCSL Outputs	0.95	1.05	1.9	V	
Ambient Operating Temperature	T _{AMB}	Commercial range	0	25	70	°C	
		Industrial range	-40	25	85	°C	
Input High Voltage	V _{IH}	Single-ended inputs, except SMBus	0.75 V _{DD}		V _{DD} + 0.3	V	
Input Mid Voltage	V _{IM}	Single-ended tri-level inputs ('_tri' suffix)	0.4 V _{DD}		0.6 V _{DD}	V	
Input Low Voltage	V _{IL}	Single-ended inputs, except SMBus	-0.3		0.25 V _{DD}	V	
Input Current	I _{IN}	Single-ended inputs, V _{IN} = GND, V _{IN} = VDD	-5		5	uA	
	I _{INP}	Single-ended inputs V _{IN} = 0 V; Inputs with internal pull-up resistors V _{IN} = VDD; Inputs with internal pull-down resistors	-200		200	uA	
Input Frequency	F _{ibyp}	Bypass mode	1		200	MHz	2
	F _{ipll}	100MHz PLL mode	60	100.00	140	MHz	2
	F _{ipll}	125MHz PLL mode	75	125.00	175	MHz	2
	F _{ipll}	50MHz PLL mode	30	50.00	65	MHz	2
Pin Inductance	L _{pin}			7	nH	1	
Capacitance	C _{IN}	Logic Inputs, except DIF_IN	1.5		5	pF	1
	C _{INDIF_IN}	DIF_IN differential clock inputs	1.5		2.7	pF	1,5
	C _{OUT}	Output pin capacitance			6	pF	1
Clk Stabilization	T _{STAB}	From V _{DD} Power-Up and after input clock stabilization or de-assertion of PD# to 1st clock			1	ms	1,2
Input SS Modulation Frequency PCIe	f _{MODINPCIe}	Allowable Frequency for PCIe Applications (Triangular Modulation)	30		33	kHz	
Input SS Modulation Frequency non-PCIe	f _{MODIN}	Allowable Frequency for non-PCIe Applications (Triangular Modulation)	0		66	kHz	
OE# Latency	t _{LATOE#}	DIF start after OE# assertion DIF stop after OE# deassertion	1		3	clocks	1,3
Tdrive_PD#	t _{DRVPD}	DIF output enable after PD# de-assertion			300	us	1,3
Tfall	t _F	Fall time of single-ended control inputs			5	ns	2
Trise	t _R	Rise time of single-ended control inputs			5	ns	2
SMBus Input Low Voltage	V _{ILSMB}	V _{DD} SMB = 3.3V, see note 4 for V _{DD} SMB < 3.3V			0.6	V	
SMBus Input High Voltage	V _{IHSMB}	V _{DD} SMB = 3.3V, see note 5 for V _{DD} SMB < 3.3V	2.1		3.6	V	4
SMBus Output Low Voltage	V _{OLSMB}	@ I _{PULLUP}			0.4	V	
SMBus Sink Current	I _{PULLUP}	@ V _{OL}	4			mA	
Nominal Bus Voltage	V _{DD} SMB	Bus Voltage	1.7		3.6	V	
SCLK/SDATA Rise Time	t _{RSMB}	(Max V _{IL} - 0.15) to (Min V _{IH} + 0.15)			1000	ns	1
SCLK/SDATA Fall Time	t _{FSMB}	(Min V _{IH} + 0.15) to (Max V _{IL} - 0.15)			300	ns	1
SMBus Operating Frequency	f _{MAXSMB}	Maximum SMBus operating frequency			400	kHz	6

¹Guaranteed by design and characterization, not 100% tested in production.

²Control input must be monotonic from 20% to 80% of input swing.

³Time from deassertion until outputs are >200mV.

⁴For V_{DD}SMB < 3.3V, V_{IHSMB} >= 0.8xV_{DD}SMB.

⁵DIF_IN input.

⁶The differential input clock must be running for the SMBus to be active.

Electrical Characteristics–Low Power HCSL Outputs

TA = T_{COM} or T_{IND}; Supply Voltages per normal operation conditions, See Test Loads for Loading Conditions

PARAMETER	SYMBOL	CONDITIONS	MIN	TYP	MAX	UNITS	NOTES
Slew rate	dV/dt	Scope averaging on, fast setting	1.7	2.7	4	V/ns	1,2,3
	dV/dt	Scope averaging on, slow setting	1.2	2.1	3.3	V/ns	1,2,3
Slew rate matching	ΔdV/dt	Slew rate matching, Scope averaging on		4.6	20	%	1,2,4
Voltage High	V _{HIGH}	Statistical measurement on single-ended signal using oscilloscope math function. (Scope averaging on)	660	774	850	mV	7
Voltage Low	V _{LOW}		-150	18	150		7
Max Voltage	V _{max}	Measurement on single ended signal using absolute value. (Scope averaging off)		820	1150	mV	7
Min Voltage	V _{min}		-300	-25			7
Vswing	V _{swing}	Scope averaging off	300	1528		mV	1,2
Crossing Voltage (abs)	V _{cross_abs}	Scope averaging off	250	413	550	mV	1,5
Crossing Voltage (var)	Δ-V _{cross}	Scope averaging off		11	140	mV	1,6

¹Guaranteed by design and characterization, not 100% tested in production.

² Measured from differential waveform

³ Slew rate is measured through the V_{swing} voltage range centered around differential 0V. This results in a +/-150mV window around differential 0V.

⁴ Matching applies to rising edge rate for Clock and falling edge rate for Clock#. It is measured using a +/-75mV window centered on the average cross point where Clock rising meets Clock# falling. The median cross point is used to calculate the voltage thresholds the oscilloscope is to use for the edge rate calculations.

⁵ V_{cross} is defined as voltage where Clock = Clock# measured on a component test board and only applies to the differential rising edge (i.e. Clock rising and Clock# falling).

⁶ The total variation of all V_{cross} measurements in any particular system. Note that this is a subset of V_{cross_min/max} (V_{cross} absolute) allowed. The intent is to limit V_{cross} induced modulation by setting Δ-V_{cross} to be smaller than V_{cross} absolute.

⁷ At default SMBus settings.

Electrical Characteristics–Current Consumption

TA = T_{COM} or T_{IND}; Supply Voltages per normal operation conditions, See Test Loads for Loading Conditions

PARAMETER	SYMBOL	CONDITIONS	MIN	TYP	MAX	UNITS	NOTES
Operating Supply Current	I _{DDA}	VDDA+VDDR, PLL Mode, @100MHz		11	15	mA	
	I _{DD}	VDD, All outputs active @100MHz		7	10	mA	
	I _{DDO}	VDDO, All outputs active @100MHz		28	35	mA	
Powerdown Current	I _{DDAPD}	VDDA+VDDR, PLL Mode, @100MHz		0.6	1	mA	2
	I _{DDPD}	VDD, Outputs Low/Low		1	2	mA	2
	I _{DDOPD}	VDDO, Outputs Low/Low		0	0.01	mA	2

¹ Guaranteed by design and characterization, not 100% tested in production.

² Input clock stopped.

Electrical Characteristics–Output Duty Cycle, Jitter, Skew and PLL Characteristics

TA = T_{COM} or T_{IND}; Supply Voltages per normal operation conditions, See Test Loads for Loading Conditions

PARAMETER	SYMBOL	CONDITIONS	MIN	TYP	MAX	UNITS	NOTES
PLL Bandwidth	BW	-3dB point in High BW Mode	2	2.7	4	MHz	1,5
		-3dB point in Low BW Mode	1	1.4	2	MHz	1,5
PLL Jitter Peaking	t _{JPEAK}	Peak Pass band Gain		1.1	2	dB	1
Duty Cycle	t _{DC}	Measured differentially, PLL Mode	45	50.1	55	%	1
Duty Cycle Distortion	t _{DCCD}	Measured differentially, Bypass Mode @100MHz	-1	0.02	1	%	1,3
Skew, Input to Output	t _{pdBYP}	Bypass Mode, V _T = 50%	3000	3636	4400	ps	1
	t _{pdPLL}	PLL Mode V _T = 50%	0	81	200	ps	1,4
Skew, Output to Output	t _{sk3}	V _T = 50%		29	50	ps	1,4
Jitter, Cycle to cycle	t _{j_{cyc-cyc}}	PLL mode		13.0	50	ps	1,2
		Additive Jitter in Bypass Mode		0.1	25	ps	1,2

¹ Guaranteed by design and characterization, not 100% tested in production.

² Measured from differential waveform

³ Duty cycle distortion is the difference in duty cycle between the output and the input clock when the device is operated in bypass mode.

⁴ All outputs at default slew rate

⁵ The MIN/TYP/MAX values of each BW setting track each other, i.e., Low BW MAX will never occur with Hi BW MIN.

Electrical Characteristics–Phase Jitter Parameters – 12kHz to 20MHz

T_{AMB} = over the specified operating range. Supply Voltages per normal operation conditions. See Test Loads for loading conditions.

Parameter	Symbol	Conditions	Minimum	Typical	Maximum	Specification Limit	Units	Notes
12k-20M Additive Phase Jitter, Fan-out Buffer Mode	t _{j_{ph}12k-20MFOB}	Fan-out Buffer Mode, SSC OFF, 156.25MHz		156		n/a	fs (rms)	1, 2, 3

Notes:

1. Applies to all differential outputs, guaranteed by design and characterization. See Test Loads for measurement setup details.

2. 12kHz to 20MHz brick wall filter.

3. For RMS values additive jitter is calculated by solving for b where $[b = \sqrt{c^2 - a^2}]$, a is rms input jitter and c is rms total jitter.

Electrical Characteristics—Additive PCIe Phase Jitter for Fanout Buffer Mode^[7]

T_{AMB} = over the specified operating range. Supply Voltages per normal operation conditions. See Test Loads for loading conditions.

Parameter	Symbol	Conditions	Minimum	Typical	Maximum	Limit	Units	Notes
Additive PCIe Phase Jitter, Fan-out Buffer Mode (Common Clocked Architecture)	t _{ph} PCleG1-CC	PCIe Gen 1 (2.5 GT/s)		1.7	3.0	86	ps (p-p)	1, 2
	t _{ph} PCleG2-CC	PCIe Gen 2 Hi Band (5.0 GT/s)		0.033	0.049	3	ps (RMS)	1, 2
		PCIe Gen 2 Lo Band (5.0 GT/s)		0.122	0.199	3.1	ps (RMS)	1, 2
	t _{ph} PCleG3-CC	PCIe Gen 3 (8.0 GT/s)		0.059	0.098	1	ps (RMS)	1, 2
	t _{ph} PCleG4-CC	PCIe Gen 4 (16.0 GT/s)		0.059	0.098	0.5	ps (RMS)	1, 2, 3, 4
	t _{ph} PCleG5-CC	PCIe Gen 5 (32.0 GT/s)		0.023	0.038	0.15	ps (RMS)	1, 2, 3, 5
Additive PCIe Phase Jitter, Fan-out Buffer Mode (SRIS Architecture)	t _{ph} PCleG1-SRIS	PCIe Gen 1 (2.5 GT/s)		0.175	0.038	n/a	ps (RMS)	1, 2, 6
	t _{ph} PCleG2-SRIS	PCIe Gen 2 (5.0 GT/s)		0.156	0.275	n/a	ps (RMS)	1, 2, 6
	t _{ph} PCleG3-SRIS	PCIe Gen 3 (8.0 GT/s)		0.041	0.247	n/a	ps (RMS)	1, 2, 6
	t _{ph} PCleG4-SRIS	PCIe Gen 4 (16.0 GT/s)		0.043	0.064	n/a	ps (RMS)	1, 2, 6
	t _{ph} PCleG5-SRIS	PCIe Gen 5 (32.0 GT/s)		0.036	0.066	n/a	ps (RMS)	1, 2, 6

Notes:

- The RefClk jitter is measured after applying the filter functions found in PCI Express Base Specification 5.0, Revision 1.0. See the Test Loads section of the data sheet for the exact measurement setup. The total RefClk jitter limits for each data rate are listed for convenience. The worst case results for each data rate are summarized in this table. If oscilloscope data is used, equipment noise is removed from all results.
- Jitter measurements shall be made with a capture of at least 100,000 clock cycles captured by a real-time oscilloscope (RTO) with a sample rate of 20 GS/s or greater. Broadband oscilloscope noise must be minimized in the measurement. The measured PP jitter is used (no extrapolation) for RTO measurements. Alternately - Jitter measurements may be used with a Phase Noise Analyzer (PNA) extending (flat) and integrating and folding the frequency content up to an offset from the carrier frequency of at least 200 MHz (at 300 MHz absolute frequency) below the Nyquist frequency. For PNA measurements for the 2.5 GT/s data rate, the RMS jitter is converted to peak to peak jitter using a multiplication factor of 8.83. In the case where real-time oscilloscope and PNA measurements have both been done and produce different results the RTO result must be used.
- SSC spurs from the fundamental and harmonics are removed up to a cutoff frequency of 2 MHz taking care to minimize removal of any non-SSC content.
- Note that 0.7 ps RMS is to be used in channel simulations to account for additional noise in a real system.
- Note that 0.25 ps RMS is to be used in channel simulations to account for additional noise in a real system.
- The PCI Express Base Specification 5.0, Revision 1.0 provides the filters necessary to calculate SRIS jitter values, however, it does not provide specification limits, hence the n/a in the Limit column. SRIS values are informative only. In general, a clock operating in an SRIS system must be twice as good as a clock operating in a Common Clock system. For RMS values, twice as good is equivalent to dividing the CC value by $\sqrt{2}$. And additional consideration is the value for which to divide by $\sqrt{2}$. The conservative approach is to divide the ref clock jitter limit, and the case can be made for dividing the channel simulation values by $\sqrt{2}$, if the ref clock is close to the Tx clock input. An example for Gen4 is as follows. A "rule-of-thumb" SRIS limit would be either $0.5\text{ps RMS}/\sqrt{2} = 0.35\text{ps RMS}$ if the clock chip is far from the clock input, or $0.7\text{ps RMS}/\sqrt{2} = 0.5\text{ps RMS}$ if the clock chip is near the clock input.
- Additive jitter for RMS values is calculated by solving for b where $b = \sqrt{c^2 - a^2}$, and a is rms input jitter and c is rms output jitter.

Additive Phase Jitter Plot: 125M (12kHz to 20MHz)

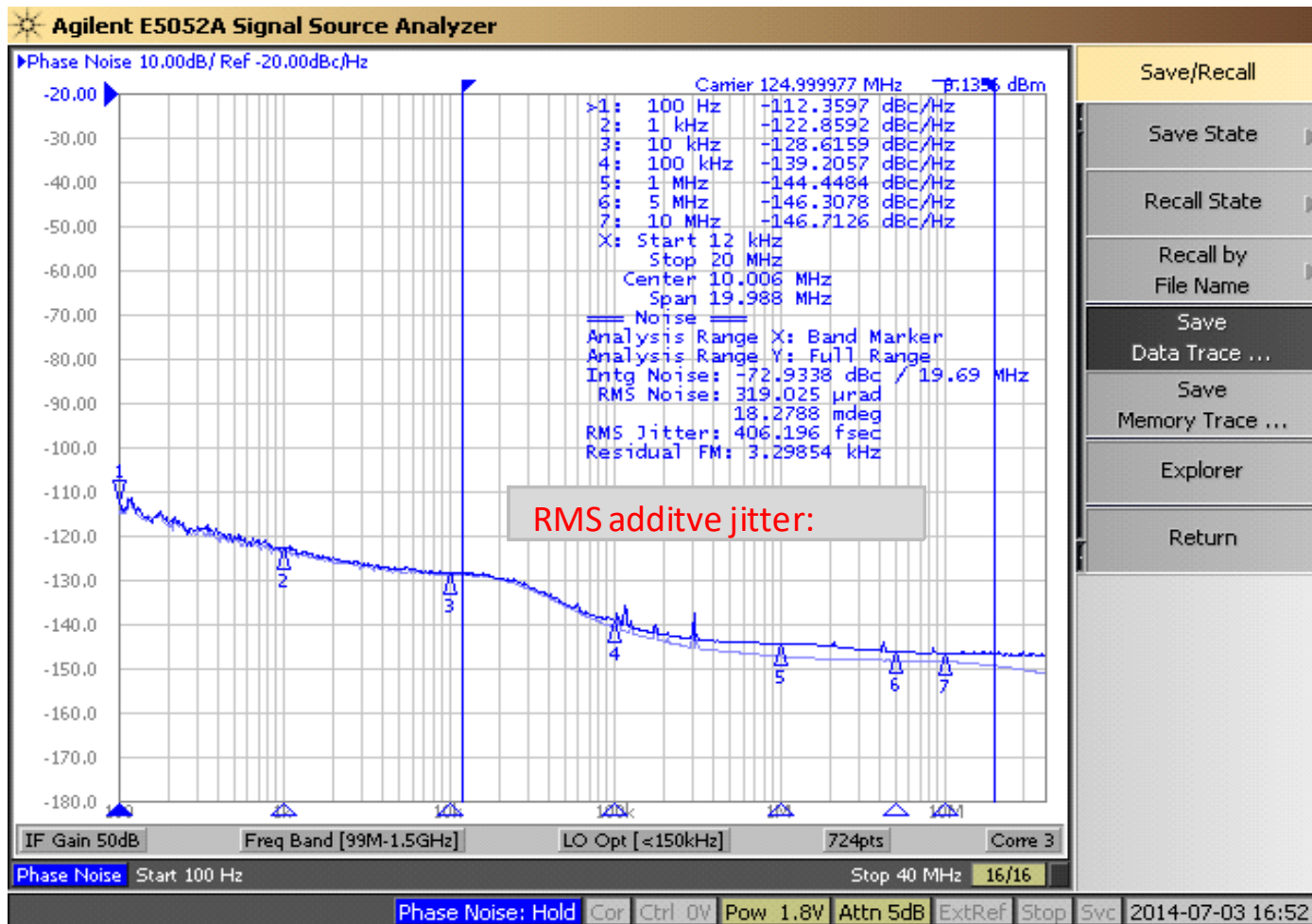

General SMBus Serial Interface Information

How to Write

- Controller (host) sends a start bit
- Controller (host) sends the write address
- Renesas clock will **acknowledge**
- Controller (host) sends the beginning byte location = N
- Renesas clock will **acknowledge**
- Controller (host) sends the byte count = X
- Renesas clock will **acknowledge**
- Controller (host) starts sending Byte N through Byte N+X-1
- Renesas clock will **acknowledge** each byte **one at a time**
- Controller (host) sends a Stop bit

How to Read

- Controller (host) will send a start bit
- Controller (host) sends the write address
- Renesas clock will **acknowledge**
- Controller (host) sends the beginning byte location = N
- Renesas clock will **acknowledge**
- Controller (host) will send a separate start bit
- Controller (host) sends the read address
- Renesas clock will **acknowledge**
- Renesas clock will send the data byte count = X
- Renesas clock sends Byte N+X-1
- Renesas clock sends **Byte 0 through Byte X (if X_(H) was written to Byte 8)**
- Controller (host) will need to acknowledge each byte
- Controller (host) will send a not acknowledge bit
- Controller (host) will send a stop bit

Index Block Write Operation			
Controller (Host)		Renesas (Slave/Receiver)	
T	starT bit		
Slave Address			
WR	WRite		
			ACK
Beginning Byte = N			
			ACK
Data Byte Count = X			
			ACK
Beginning Byte N		X Byte	
			ACK
O			O
O			O
			O
Byte N + X - 1			
			ACK
P	stoP bit		

Index Block Read Operation			
Controller (Host)		Renesas	
T	starT bit		
Slave Address			
WR	WRite		
			ACK
Beginning Byte = N			
			ACK
RT	Repeat starT		
Slave Address			
RD	ReaD		
			ACK
ACK			
ACK			
		X Byte	
O			O
O			O
O			O
ACK			
ACK			
ACK			
ACK			
ACK			
ACK			
ACK			
ACK			
ACK			
ACK			
ACK			
ACK			
ACK			
ACK			
ACK			
ACK			
N	Not acknowledge		
P	stoP bit		

Note: SMBus address is latched on SADR pin.

SMBus Table: Output Enable Register ¹

Byte 0	Name	Control Function	Type	0	1	Default
Bit 7	DIF OE7	Output Enable	RW	Low/Low	Enabled	1
Bit 6	DIF OE6	Output Enable	RW	Low/Low	Enabled	1
Bit 5	DIF OE5	Output Enable	RW	Low/Low	Enabled	1
Bit 4	DIF OE4	Output Enable	RW	Low/Low	Enabled	1
Bit 3	DIF OE3	Output Enable	RW	Low/Low	Enabled	1
Bit 2	DIF OE2	Output Enable	RW	Low/Low	Enabled	1
Bit 1	DIF OE1	Output Enable	RW	Low/Low	Enabled	1
Bit 0	DIF OE0	Output Enable	RW	Low/Low	Enabled	1

1. A low on these bits will override the OE# pin and force the differential output Low/Low

SMBus Table: PLL Operating Mode and Output Amplitude Control Register

Byte 1	Name	Control Function	Type	0	1	Default
Bit 7	PLLMODERB1	PLL Mode Readback Bit 1	R	See PLL Operating Mode Table		Latch
Bit 6	PLLMODERB0	PLL Mode Readback Bit 0	R			Latch
Bit 5	PLLMODE_SWCNTRL	Enable SW control of PLL Mode	RW	Values in B1[7:6] set PLL Mode	Values in B1[4:3] set PLL Mode	0
Bit 4	PLLMODE1	PLL Mode Control Bit 1	RW ¹	See PLL Operating Mode Table		0
Bit 3	PLLMODE0	PLL Mode Control Bit 0	RW ¹			0
Bit 2	Reserved					1
Bit 1	AMPLITUDE 1	Controls Output Amplitude	RW	00 = 0.6V	01 = 0.7V	1
Bit 0	AMPLITUDE 0		RW	10 = 0.8V	11 = 0.9V	0

1. B1[5] must be set to a 1 for these bits to have any effect on the part.

SMBus Table: DIF Slew Rate Control Register

Byte 2	Name	Control Function	Type	0	1	Default
Bit 7	SLEWRATESEL DIF7	Adjust Slew Rate of DIF7	RW	Slow Setting	Fast Setting	1
Bit 6	SLEWRATESEL DIF6	Adjust Slew Rate of DIF6	RW	Slow Setting	Fast Setting	1
Bit 5	SLEWRATESEL DIF5	Adjust Slew Rate of DIF5	RW	Slow Setting	Fast Setting	1
Bit 4	SLEWRATESEL DIF4	Adjust Slew Rate of DIF4	RW	Slow Setting	Fast Setting	1
Bit 3	SLEWRATESEL DIF3	Adjust Slew Rate of DIF3	RW	Slow Setting	Fast Setting	1
Bit 2	SLEWRATESEL DIF2	Adjust Slew Rate of DIF2	RW	Slow Setting	Fast Setting	1
Bit 1	SLEWRATESEL DIF1	Adjust Slew Rate of DIF1	RW	Slow Setting	Fast Setting	1
Bit 0	SLEWRATESEL DIF0	Adjust Slew Rate of DIF0	RW	Slow Setting	Fast Setting	1

f

SMBus Table: Frequency Select Control Register

Byte 3	Name	Control Function	Type	0	1	Default
Bit 7	Reserved					1
Bit 6	Reserved					1
Bit 5	FREQ_SEL_EN	Enable SW selection of frequency	RW	SW frequency change disabled	SW frequency change enabled	0
Bit 4	FSEL1	Freq. Select Bit 1	RW ¹	See Frequency Select Table		0
Bit 3	FSEL0	Freq. Select Bit 0	RW ¹			0
Bit 2	Reserved					1
Bit 1	Reserved					1
Bit 0	SLEWRATESEL FB	Adjust Slew Rate of FB	RW	2.0V/ns	3.0V/ns	1

1. B3[5] must be set to a 1 for these bits to have any effect on the part.

Byte 4 is Reserved and reads back 'hFF'

SMBus Table: Revision and Vendor ID Register

Byte 5	Name	Control Function	Type	0	1	Default
Bit 7	RID3	Revision ID	R	A rev = 0001		0
Bit 6	RID2		R			0
Bit 5	RID1		R			0
Bit 4	RID0		R			0
Bit 3	VID3	VENDOR ID	R	0001 = IDT		0
Bit 2	VID2		R			0
Bit 1	VID1		R			0
Bit 0	VID0		R			1

SMBus Table: Device Type/Device ID

Byte 6	Name	Control Function	Type	0	1	Default
Bit 7	Device Type1	Device Type	R	00 = FGx, 01 = DBx, 10 = DMx, 11= Reserved		0
Bit 6	Device Type0		R			1
Bit 5	Device ID5	Device ID	R	001000 binary or 08 hex		0
Bit 4	Device ID4		R			0
Bit 3	Device ID3		R			1
Bit 2	Device ID2		R			0
Bit 1	Device ID1		R			0
Bit 0	Device ID0		R			0

SMBus Table: Byte Count Register

Byte 7	Name	Control Function	Type	0	1	Default
Bit 7	Reserved					0
Bit 6	Reserved					0
Bit 5	Reserved					0
Bit 4	BC4	Byte Count Programming	RW	Writing to this register will configure how many bytes will be read back, default is = 8 bytes.		0
Bit 3	BC3		RW			1
Bit 2	BC2		RW			0
Bit 1	BC1		RW			0
Bit 0	BC0		RW			0

Marking Diagrams

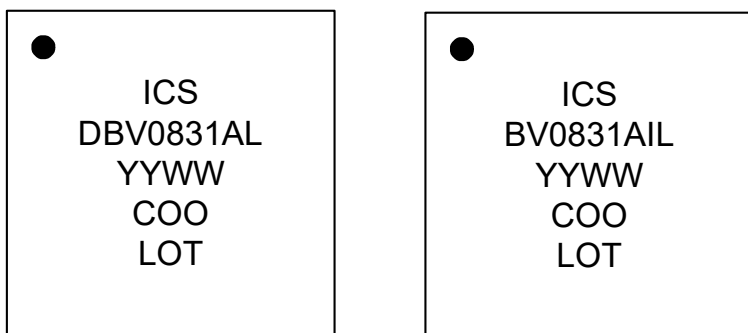

Notes:

1. "LOT" is the lot sequence number.
2. "COO" denotes country of origin.
3. YYWW is the last two digits of the year and week that the part was assembled.
4. Line 2: truncated part number
5. "L" denotes RoHS compliant package.
6. "I" denotes industrial temperature range device.

Thermal Characteristics

PARAMETER	SYMBOL	CONDITIONS	PKG	TYP VALUE	UNITS	NOTES
Thermal Resistance	θ_{JC}	Junction to Case	NDG48	33	°C/W	1
	θ_{Jb}	Junction to Base		2.1	°C/W	1
	θ_{JA0}	Junction to Air, still air		37	°C/W	1
	θ_{JA1}	Junction to Air, 1 m/s air flow		30	°C/W	1
	θ_{JA3}	Junction to Air, 3 m/s air flow		27	°C/W	1
	θ_{JA5}	Junction to Air, 5 m/s air flow		26	°C/W	1

¹ePad soldered to board

Package Outline Drawings

The package outline drawings are located at the end of this document and are accessible from the Renesas website. The package information is the most current data available and is subject to change without revision of this document.

[48-VFQFPN \(NDG48P1\)](#)

Ordering Information

Part / Order Number	Shipping Packaging	Package	Temperature
9DBV0831AKLF	Trays	48-VFQFPN	0 to +70° C
9DBV0831AKLFT	Tape and Reel	48-VFQFPN	0 to +70° C
9DBV0831AKILF	Trays	48-VFQFPN	-40 to +85° C
9DBV0831AKILFT	Tape and Reel	48-VFQFPN	-40 to +85° C

“LF” suffix to the part number are the Pb-Free configuration and are RoHS compliant.

“A” is the device revision designator (will not correlate with the datasheet revision).

Revision History

Revision Date	Description
March 22, 2012	<ol style="list-style-type: none"> Updated electrical tables with typical data from characterization. Updated ordering information to indicate B rev device. Data sheet title change to indicate PCIe Gen1/2/3. Move to preliminary.
July 6, 2012	<ol style="list-style-type: none"> Extensive changes to page 1 text: Description, Recommended Application, Output Features, Features/Benefits, DS Title. Indicated default value in Frequency Select Table. Pins 3,4 changed from FB,FB# to FB_DNC,FB_DNC# to indicate that these pins are Do Not Connect (DNC).
July 10, 2012	<ol style="list-style-type: none"> Removed 156.25M from input frequency specification.
August 13, 2012	<ol style="list-style-type: none"> Removed "Differential" from DS title and Recommended Application, corrected typo's in Description. Removed references to 60KOhm pulldown under pinout. Updated "Phase Jitter Parameters" table by adding "Industry Limit" column and updated all Electrical Tables with characterization data. Updated Byte3[0] to be consistent with Byte 2. Updated Byte6[7:6] definition. Updated Mark spec with correct part revision (A) and added thermal data to page 13. Added NDG48 to "Package Outline and Package Dimensions" on page 14 and updated Ordering information to correct part revision (A rev). Move to final.
February 25, 2013	<ol style="list-style-type: none"> Changed VIH min. from 0.65*VDD to 0.75*VDD Changed VIL max. from 0.35*VDD to 0.25*VDD Added missing mid-level input voltage spec (VIM) of 0.4*VDD to 0.6*VDD.
August 12, 2014	Changed package designator from "MLF" to "VFQFPN"
March 2, 2015	<ol style="list-style-type: none"> Minor formatting updates to electrical tables. Added callout for EPAD. Updated block diagram to latest format. Updated front page text to latest format. Added additive phase jitter plot. Corrected Byte 2 and Byte 5 in SMBus.
April 28, 2016	<ol style="list-style-type: none"> Updated max frequency of 100MHz PLL mode to 140MHz Updated max frequency of 125MHz PLL mode to 175MHz Updated max frequency of 50MHz PLL mode to 65MHz
July 26, 2021	<ol style="list-style-type: none"> Added new Electrical Characteristics–Phase Jitter Parameters tables. Updated datasheet title. Updated Recommended Applications. Updated Key Specifications. Updated Package Outline Drawings section.

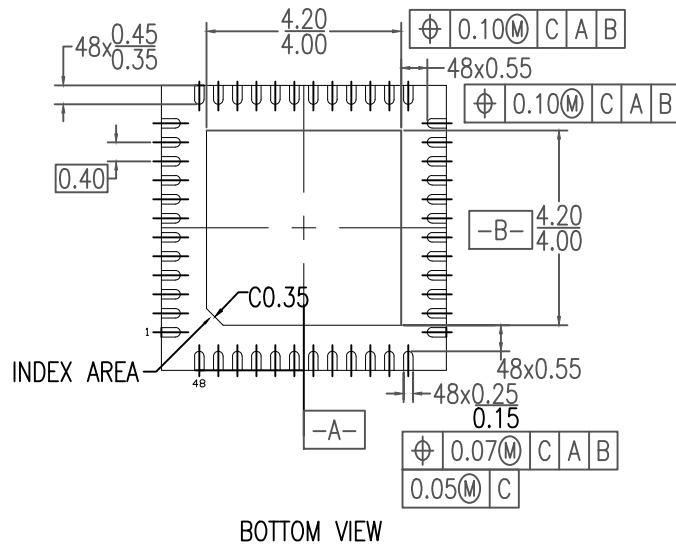
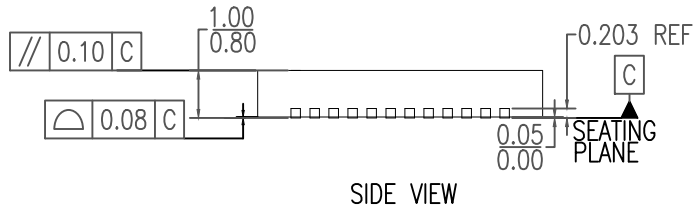
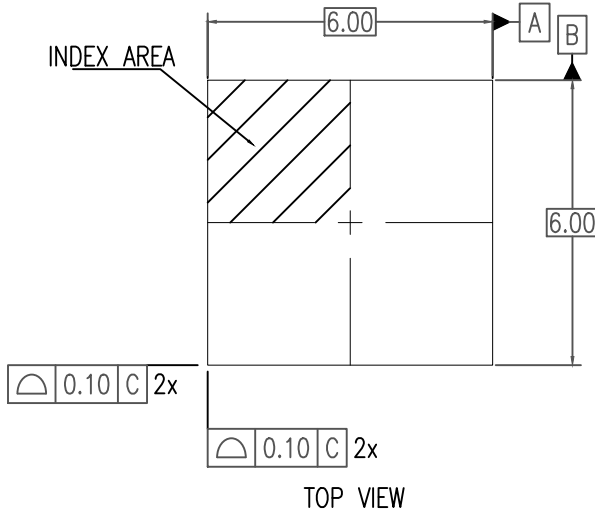

- NOTES:
1. ALL DIMENSIONING AND TOLERANCING CONFORM TO ANSI Y14.5M-1982
 2. ALL DIMENSIONS ARE IN MILLIMETERS.

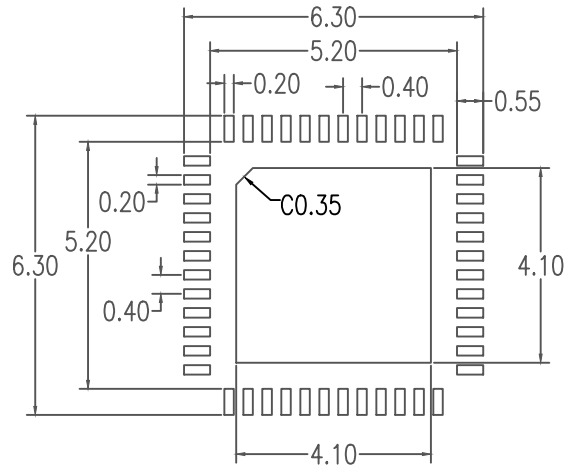

RECOMMENDED LAND PATTERN DIMENSION

NOTES:

1. ALL DIMENSION ARE IN MM. ANGLES IN DEGREES.
2. TOP DOWN VIEW. AS VIEWED ON PCB.
3. LAND PATTERN RECOMMENDATION PER IPC-7351B GENERIC REQUIREMENT FOR SURFACE MOUNT DESIGN AND LAND PATTERN.

Package Revision History		
Date Created	Rev No.	Description
Aug16, 2018	Rev 01	New Format Change QFN to VFQFPN, Recalculate Land Pattern
May 6, 2016	Rev 00	Add Chamfer

IMPORTANT NOTICE AND DISCLAIMER

RENESAS ELECTRONICS CORPORATION AND ITS SUBSIDIARIES (“RENESAS”) PROVIDES TECHNICAL SPECIFICATIONS AND RELIABILITY DATA (INCLUDING DATASHEETS), DESIGN RESOURCES (INCLUDING REFERENCE DESIGNS), APPLICATION OR OTHER DESIGN ADVICE, WEB TOOLS, SAFETY INFORMATION, AND OTHER RESOURCES “AS IS” AND WITH ALL FAULTS, AND DISCLAIMS ALL WARRANTIES, EXPRESS OR IMPLIED, INCLUDING, WITHOUT LIMITATION, ANY IMPLIED WARRANTIES OF MERCHANTABILITY, FITNESS FOR A PARTICULAR PURPOSE, OR NON-INFRINGEMENT OF THIRD PARTY INTELLECTUAL PROPERTY RIGHTS.

These resources are intended for developers skilled in the art designing with Renesas products. You are solely responsible for (1) selecting the appropriate products for your application, (2) designing, validating, and testing your application, and (3) ensuring your application meets applicable standards, and any other safety, security, or other requirements. These resources are subject to change without notice. Renesas grants you permission to use these resources only for development of an application that uses Renesas products. Other reproduction or use of these resources is strictly prohibited. No license is granted to any other Renesas intellectual property or to any third party intellectual property. Renesas disclaims responsibility for, and you will fully indemnify Renesas and its representatives against, any claims, damages, costs, losses, or liabilities arising out of your use of these resources. Renesas' products are provided only subject to Renesas' Terms and Conditions of Sale or other applicable terms agreed to in writing. No use of any Renesas resources expands or otherwise alters any applicable warranties or warranty disclaimers for these products.

(Rev.1.0 Mar 2020)

Corporate Headquarters

TOYOSU FORESIA, 3-2-24 Toyosu,
Koto-ku, Tokyo 135-0061, Japan
www.renesas.com

Contact Information

For further information on a product, technology, the most up-to-date version of a document, or your nearest sales office, please visit:
www.renesas.com/contact/

Trademarks

Renesas and the Renesas logo are trademarks of Renesas Electronics Corporation. All trademarks and registered trademarks are the property of their respective owners.

X-ON Electronics

Largest Supplier of Electrical and Electronic Components

Click to view similar products for [Clock Buffer](#) category:

Click to view products by [Renesas](#) manufacturer:

Other Similar products are found below :

[MPC962309EJ-1H](#) [NB4N121KMNG](#) [IDT49FCT805ASO](#) [MK2308S-1HILF](#) [PL133-27GI-R](#) [NB3L02FCT2G](#) [NB3L03FCT2G](#)
[ZL40203LDG1](#) [ZL40200LDG1](#) [ZL40205LDG1](#) [9FG1200DF-1LF](#) [9FG1001BGLF](#) [ZL40202LDG1](#) [PI49FCT20802QE](#) [SL2305SC-1T](#)
[PI6C4931502-04LIE](#) [NB7L1008MNG](#) [NB7L14MN1G](#) [PI49FCT20807QE](#) [PI6C4931502-04LIEX](#) [ZL80002QAB1](#) [PI6C4931504-04LIEX](#)
[PI6C10806BLEX](#) [ZL40226LDG1](#) [ZL40219LDG1](#) [8T73S208B-01NLGI](#) [SY75578LMG](#) [PI49FCT32805QEX](#) [PL133-27GC-R](#)
[CDCV304PWG4](#) [MC10LVEP11DG](#) [MC10EP11DTG](#) [MC100LVEP11DG](#) [MC100E111FNG](#) [MC100EP11DTG](#) [NB6N11SMNG](#)
[NB7L14MMNG](#) [NB6L11MMNG](#) [NB6L14MMNR2G](#) [NB6L611MNG](#) [PL123-02NGI-R](#) [NB3N111KMNR4G](#) [ADCLK944BCPZ-R7](#)
[ZL40217LDG1](#) [NB7LQ572MNG](#) [HMC940LC4BTR](#) [ADCLK946BCPZ-REEL7](#) [ADCLK946BCPZ](#) [ADCLK846BCPZ-REEL7](#)
[ADCLK854BCPZ-REEL7](#)