

IDT TIMING SOLUTIONS

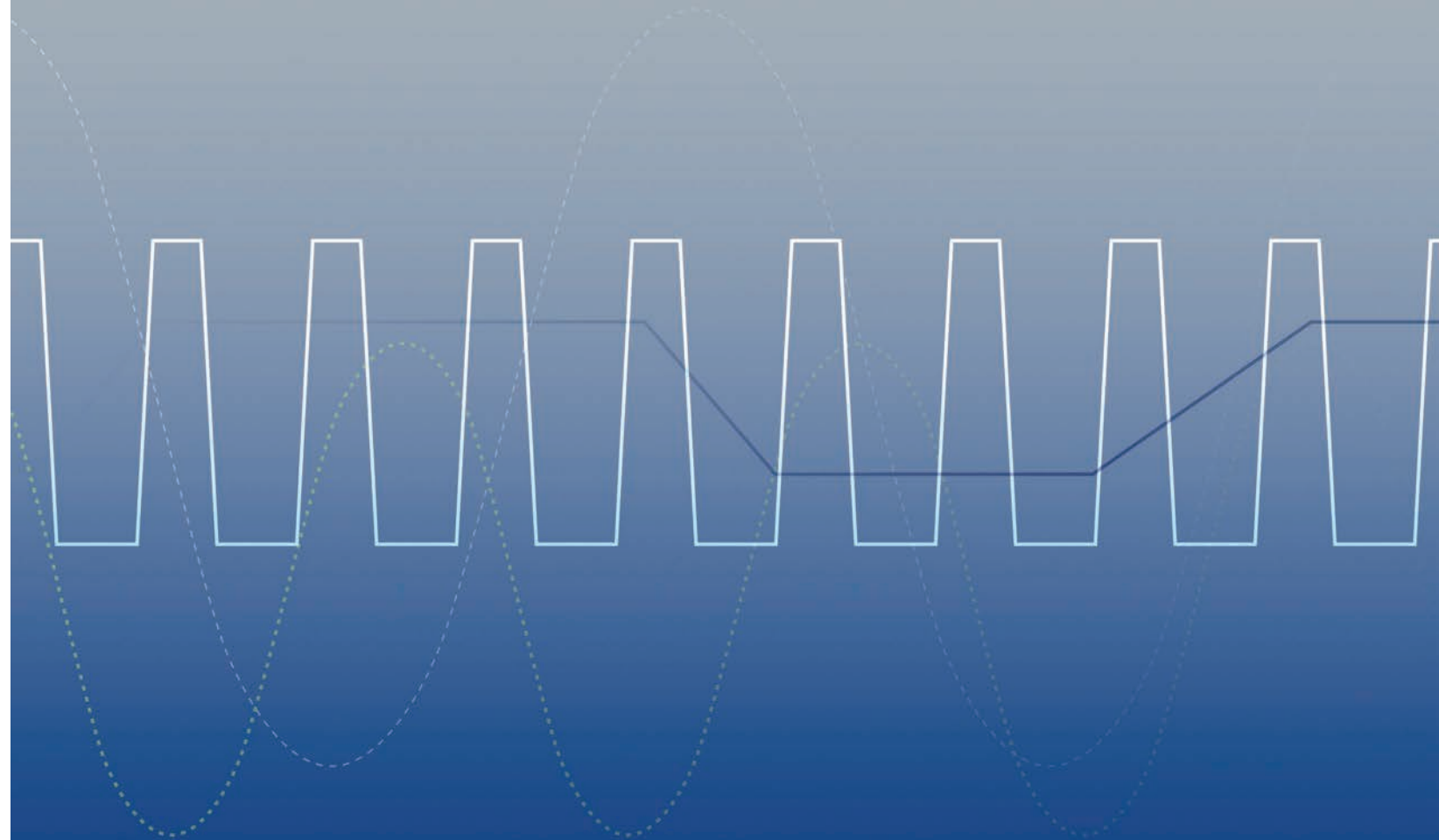

THE LEADER IN TIMING SOLUTIONS.



With a product portfolio that is 10 times greater than the nearest competitor, IDT is in a unique position to address your timing needs. We are the industry's only one-stop-shop for timing, from fully-featured products like the Universal Frequency Translator, WAN PLL and VersaClock families, through simple clock building-block products like fanout buffers and multiplexers. IDT has a multitude of products that are optimized for specific applications, including several that are featured on the reference designs of silicon-vendor partners.

WORLDWIDE SALES



We utilize a broad spectrum sales channel for the greatest flexibility in getting you the products you need. For a comprehensive list of sales office and Distributors world-wide, please visit our website at : www.idt.com/buy-sample/locations

DISCLAIMER Integrated Device Technology, Inc. (IDT) and its subsidiaries reserve the right to modify the products and/or specifications described herein at any time and at IDT's sole discretion. All information in this document, including descriptions of product features and performance, is subject to change without notice. Performance specifications and the operating parameters of the described products are determined in the independent state and are not guaranteed to perform the same way when installed in customer products. The information contained herein is provided without representation or warranty of any kind, whether express or implied, including, but not limited to, the suitability of IDT's products for any particular purpose, an implied warranty of merchantability, or non-infringement of the intellectual property rights of others. This document is presented only as a guide and does not convey any license under intellectual property rights of IDT or any third parties. IDT's products are not intended for use in life support systems or similar devices where the failure or malfunction of an IDT product can be reasonably expected to significantly affect the health or safety of users. Anyone using an IDT product in such a manner does so at their own risk, absent an express, written agreement by IDT.

Integrated Device Technology, IDT and the IDT logo are registered trademarks of IDT. Other trademarks and service marks used herein, including protected names, logos and designs, are the property of IDT or their respective third party owners. © Copyright 2012. All rights reserved.

CONTENTS

NON-PLL CLOCK DISTRIBUTION

Fanout Buffers and Dividers	4
Multiplexers and Fanout Multiplexers	6

CLOCK GENERATORS, SYNTHESIZERS AND ZERO DELAY BUFFERS

General Purpose Clock Generators, Synthesizers and Zero Delay Buffers	8
FemtoClock® Low Phase-Noise Frequency Synthesizers	10
VersaClock® III Programmable Clocks	12
VersaClock® LP Programmable Clocks	13
Spread-Spectrum Clocks	14

JITTER ATTENUATION AND FREQUENCY TRANSLATION

Universal Frequency Translators (UFT)	16
VCXO PLL Jitter Attenuators	17
VCSO PLL Jitter Attenuator Modules	18

NETWORK SYNCHRONIZATION WAN PLLS

PDH and SONET/SDH	20
Synchronous Ethernet and IEEE 1588	21

APPLICATION-SPECIFIC CLOCKS

Computing Clocks	24
PCI Express® Clocks	25
Video Clocks	26
Real Time Clocks	27

CRYSTALS, OSCILLATORS AND CRYSTALFREE FREQUENCY CONTROL PRODUCTS (FCP)

Fox Electronics Crystals	30
Fox Electronics Xpresso® Oscillators	32
Fox Electronics Oscillators	34
Fox Electronics TCXO and OCXOs	36
Quartz-Crystal and SAW Oscillators	37
CrystalFree™ Piezo MEMS (pMEMS™) Oscillators and Crystal Replacements	38

PARTNER ATTACH GUIDES

Xilinx FPGA	40
Freescale QorIQ Broadcom Switch/PHY	42
Freescale iMX	45
Cavium Designs	46
Altera FPGA	47
Broadcom BCM54382	49
Broadcom Switch/PHY	50
Intel Atom	52

RESOURCES

Clock Solution Customization	56
Part Number Legend	57



IDT CLOCK DISTRIBUTION PRODUCTS ARE
NON-PLL DEVICES THAT ARE USED TO
CONDITION, MANIPULATE AND DISTRIBUTE
CLOCK SIGNALS WITHIN AN APPLICATION.

NON-PLL CLOCK DISTRIBUTION

Fanout Buffers and Dividers	4
Multiplexers and Fanout Multiplexers	6



Fanout Buffers and Dividers

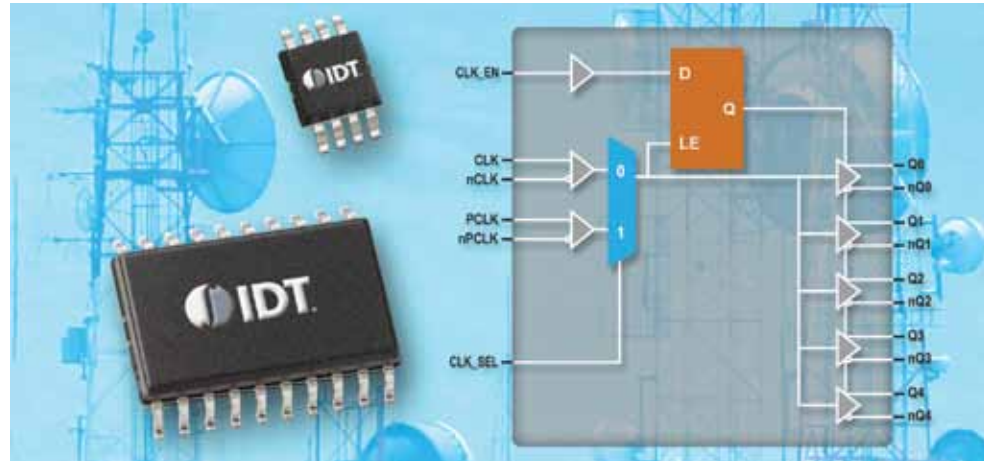

Fanout buffers are a useful building block of many clock trees, providing signal buffering and multiple low-skew copies of the input signal. The clock fanout from a single input reduces loading on the preceding driver and provides an efficient clock distribution network. Single output buffers are useful for translating a clock from one signaling standard to another (e.g. LVCMOS-in to LVPECL-out). Some devices have an integrated crystal oscillator, requiring only a low cost external fundamental-mode quartz crystal. The integrated oscillator provides an extremely low phase noise reference clock to drive jitter-sensitive devices such as the clock inputs of PHYs.

Clock dividers provide an output clock signal that is a divided frequency of the input. They can also be used to provide signal buffering and make multiple copies of the output frequency. Clock divider devices, when used in divide-by-1 mode, can also function as a fanout buffer.

FEATURES

- Devices with up to 27 outputs
- Output dividers up to divide-by-32
- Single-ended or differential outputs such as LVPECL, LVDS, HSTL, SSTL and CML available
- PCIe compliant HCSL outputs
- Differential output frequencies up to 3.2 GHz and single ended LVCMOS outputs for frequencies up to 350 MHz
- Extremely low output to output skew
- Operating voltages from 1.2V to 5V
- Crystal fan-out buffers have an internal oscillator
- Some buffers are available with mixed output signaling
- Industrial temperature range available

BENEFITS

- Extremely low additive phase noise to drive jitter sensitive devices
- Full differential internal architecture improves jitter performance
- Well suited for use in consumer, computing and embedded applications as well as networking, communications and high-end computing systems

Part Number	# of Outputs	# of Output Banks	Output Type	Output Frequency (MHz)	Supply Voltage (V)	Input Frequency (MHz)	Input Type	# of Inputs	Divider Value	Output Skew (ps)	Additive Phase Jitter RMS (ps)	Package Type
87332I-01	1	1	LVPECL	0 - 500	2.5, 3.3	0 - 1000	LVPECL, LVDS, LVHSTL, SSTL, HCSL	1	2	N/A	N/A	8-SOIC
87354I	1	1	LVPECL	0 - 250	3.3	0 - 1000	LVDS, LVPECL, LVHSTL, SSTL, HCSL, LVCMOS, GTL	1	4, 5	N/A	N/A	8-SOIC
74FCT38072	2	1	LVCMOS, TTL	0-166	3.3	0-166	LVCMOS, TTL	1	N/A	100	N/A	8-SOIC
8SLVP1102I	2	1	LVPECL	0-2000	2.5, 3.3	0 - 2000	CML, LVDS, LVPECL	1	N/A	15	0.036	16-VFOFPN
9DB102	2	2	HCSL	100	3.3	100	Differential	1	N/A	< 25	< 86 PCIe Gen 1, < 3.1 PCIe Gen 2	20-QSOP, 20/28-SSOP, 28-TSSOP
8S89871I	3	2	LVPECL	0 - 2500	2.5, 3.3	0 - 3200	CML, LVDS, LVPECL	1	1, 2, 4, 8, 16	55	0.15	16-VFOFN
553	4	1	LVCMOS	0 - 200	2.5, 3.3, 5	0 - 200	LVCMOS	1	N/A	50	N/A	8-SOIC
621	4	1	LVCMOS	0 - 200	1.2, 1.5, 1.8	0 - 200	LVCMOS	1	N/A	150	N/A	8-SOIC, 8-VFOFPN
8543	4	1	LVDS	0 - 800	3.3	0 - 800	CML, HCSL, HSTL, LVDS, LVPECL, SSTL	2	N/A	40	0.164	20-TSSOP
830154I-08	4	1	LVCMOS	0 - 160	1.5, 1.8, 2.5, 3.3	0 - 160	LVCMOS	1	N/A	250	0.094	8-SOIC, 8-TSSOP
8533I-01	4	1	LVPECL	0 - 650	3.3	0 - 650	CML, HCSL, HSTL, LVDS, LVPECL, SSTL	2	N/A	30	0.06	20-TSSOP
524	4	1	LVCMOS	0-200	2.5 - 5	0-200	LVCMOS	1	N/A	50	NA	8-SOIC
551	4	1	LVCMOS	0-160	3.3, 5	0-160	LVCMOS	1	N/A	250	N/A	8-SOIC
8SLVP2102I	4	2	LVPECL	0 - 2000	2.5, 3.3	0 - 2000	CML, LVDS, LVPECL	2	N/A	15	0.031	16-VFOFPN
9DB403D	4	4	HCSL	100	3.3	100	Differential	1	N/A	< 50	< 3.1 PCIe Gen 1, < 86 PCIe Gen 2	28-TSSOP
9DBL411B	4	1	LVCMOS	15 - 150	1.8, 2.5, 3.3	15 - 150	LVCMOS	1	N/A	50	0.04	20-MLF, 20-TSSOP

IDT TIMING SOLUTIONS

Part Number	# of Outputs	# of Output Banks	Output Type	Output Frequency (MHz)	Output Voltage (V)	Input Frequency (MHz)	Input Type	# of Inputs	Divider Value	Output Skew (ps)	Additive Phase Jitter RMS (ps)	Package Type
5V2305	5	1	LVC MOS, TTL	0-200	2.5, 3.3	0-200	LVC MOS, TTL	1	N/A	75	N/A	16-TSSOP, 16-VFQFPN
85214I	5	1	HSTL	0 - 700	1.8	0 - 700	HCSL, LVC MOS, LVDS, HSTL, LVPECL	2	N/A	40	N/A	20-TSSOP
85314I-01	5	1	LVPECL	0 - 700	2.5, 3.3	0 - 700	HCSL, LVC MOS, LVDS, HSTL, LVPECL, SSTL	2	N/A	30	0.05	20-TSSOP, 20-SOIC
854S015-01	5	1	LVDS, LVPECL	0 - 2000	2.5, 3.3	0 - 2000	CML, HCSL, LVDS, HSTL, LVPECL	2	N/A	25	0.065	24-VFQFPN
853S006I	6	1	LVPECL	0 - 2000	2.5, 3.3	0 - 2000	CML, LVDS, LVPECL	1	N/A	50	0.08	20-TSSOP
8546-01	6	1	LVDS	0 - 266	2.5, 3.3	14 - 40	Crystal, HCSL, LVDS, LVC MOS, HSTL, LVPECL	3	N/A	50	0.232	24-TSSOP
9DB106	6	3	HCSL	100	3.3	100	Differential	1	N/A	< 25	< 3.1 PCIe Gen 1, < 86 PCIe Gen 2	20-OSOP, 20/28-SSOP, 28-TSSOP
9P936	6	1	LVC MOS	45 - 500	1.8, 2.5	45 - 500	LVC MOS	1	N/A	40	N/A	28-TSSOP
552G-02	8	1	LVC MOS	0-200	2.5-5	0-200	LVC MOS	1	N/A	50	N/A	16-TSSOP
85408I	8	1	LVDS	0 - 700	3.3	0 - 700	HCSL, HSTL, LVDS, LVPECL, SSTL	1	N/A	50	0.167	24-TSSOP
8SLVP2104I	8	2	LVPECL	0 - 2000	2.5, 3.3	0 - 2000	CML, LVDS, LVPECL	2	N/A	25	0.043	28-VFQFPN
8T73S208I	8	1	LVPECL	0 - 1000	2.5, 3.3	0 - 1000	CML, LVDS, LVPECL	1	1, 2, 4, 8	60	0.051	32-VFQFN
9DB803D	8	4	HCSL	100	3.3	100, 133	Differential	1	N/A	< 50	< 86 PCIe Gen 1, < 3.1 PCIe Gen 2	48-TSSOP
49FCT3805	10	2	TTL	0-166	3.3, 5	0-166	TTL	2	N/A	500	N/A	20-SSOP, 20-OSOP, 20-SOIC
49FCT805A	10	2	LVC MOS, TTL	0-166	5	0-166	LVC MOS, TTL	2	N/A	700	N/A	20-SSOP, 20-SOIC
5V2310	10	2	LVC MOS, TTL	0-200	2.5, 3.3	0-200	LVC MOS, TTL	1	N/A	100	N/A	24-TSSOP
851010I	10	1	HCSL	0 - 250	3.3	0 - 250	HCSL, LVDS, HSTL, LVPECL	1	N/A	165	0.19	32-LQFP
8T53S111I	10	1	LVPECL	0 - 2500	2.5, 3.3	0 - 2500	LVDS, LVPECL	3	N/A	15	0.03	32-VFQFN
LV810	10	3	LVC MOS	1 - 133	1.5, 2.5	1 - 133	LVC MOS	1	N/A	200	N/A	20-OSOP, 20-SSOP
9ZX21200	12	1	HCSL	0 - 150	3.3	33 - 147	HCSL	1	N/A	65	PCIe Gen1/Gen2/Gen3, OPI	56-VFQFPN
9ZXL1230	12	1	HCSL	0 - 400	1.05 - 3.3	33 - 147	LVC MOS	1	N/A	65	PCIe Gen1/Gen2/Gen3, OPI	56-VFQFPN
9ZXL1231	12	1	HCSL	0 - 400	1.05 - 3.3	33 - 147	LVC MOS	1	N/A	65	PCIe Gen1/Gen2/Gen3, OPI	64-VFQFPN
MK74CB218	16	2	LVC MOS, TTL	0-200	3.3	0-200	LVC MOS, TTL	2	N/A	250	N/A	28-OSOP
8SLVP2108I	16	2	LVPECL	0 - 2000	2.5, 3.3	0 - 2000	LVDS, LVPECL	2	N/A	63	0.043	48-VFQFN
9DB823	16	8	HCSL	100, 133	3.3	100, 133	Differential	1	N/A	< 50	< 86 PCIe Gen 1, < 3.1 PCIe Gen 2, < 0.5 OPI	48-SSOP, 48-TSSOP
83918I	18	1	LVC MOS	0 - 200	1.8, 2.5, 3.3	12 - 40	Crystal, LVC MOS	2	N/A	75	0.145	32-TOFP
83940DI	18	1	LVC MOS	0 - 250	2.5, 3.3	0 - 250	CML, LVC MOS, LVPECL, SSTL	2	N/A	150	N/A	32-VFQFPN, 32-TOFP
874328I-01	20	6	LVDS, LVPECL	0 - 650	2.5	0 - 650	CML, LVDS, LVPECL, SSTL	1	1, 4	70	0.05	64-TOFP
MC100ES6221	20	1	LVPECL	0 - 2000	2.5, 3.3	0 - 2000	HSTL, LVPECL	2	N/A	100	N/A	52-PTOFP
8344I-01	24	1	LVC MOS	0 - 100	2.5, 3.3	0 - 100	HCSL, LVDS, HSTL, LVPECL	2	N/A	200	0.21	48-TOFP
MPC941	27	1	LVC MOS	0 - 250	2.5, 3.3	0 - 250	LVC MOS, LVPECL	2	N/A	2.5, 3.3	N/A	48-TOFP

These products represent only a portion of IDT's Fanout Buffer and Divider portfolio. For information on additional devices, please visit www.idt.com/timing/fanout-buffers

Multiplexers and Fanout Multiplexers



IDT multiplexers allow the selection from multiple clock inputs to drive the Output. Devices are available with fanout capability, providing multiple copies of the output signal. Some devices have integrated crystal oscillators, requiring only low cost external fundamental-mode quartz crystals. The integrated oscillators provide an extremely low phase noise reference clock to drive jitter sensitive devices such as the clock inputs of PHYs. Others are available that can translate the input clock from one signaling level to another (e.g. LVCMOS-in to LVPECL-out).

IDT's "8" series of multiplexers feature fully differential internal architecture, even devices with single-ended I/Os. This improves jitter due to inherent common-mode noise rejection and improves output skew. The differential circuitry is constant current and therefore injects less noise into system power supplies than single-ended solutions, reducing noise and decreasing EMI compliance concerns.

The IDT multiplexer portfolio includes devices with up to 16 inputs. Differential outputs such as LVPECL, LVDS, HCSL, CML, HSTL, as well as selectable outputs, are supported for output frequencies up to 3.2 GHz and single-ended LVCMOS outputs for frequencies up to 350 MHz. IDT's multiplexer portfolio has devices supporting supply voltages from 1.2 V up to 5 V and that are available in the commercial and industrial temperature ranges.

FEATURES

- Devices with up to 16 inputs
- 1.8V, 2.5V or 3.3V supply modes
- Differential outputs such as LVPECL, LVDS, HSTL and SSTL
- >-50 db MUX isolation between input paths
- Support for differential output frequencies up to 3.2 GHz and single ended LVCMOS outputs for frequencies up to 350 MHz

BENEFITS

- Outputs can be driven by selectable input
- Low phase noise to drive jitter sensitive devices
- Full differential internal architecture improves jitter performance
- Wide variety of output styles

Part Number	# of Inputs	Input Type	Input Frequency (MHz)	# of Outputs	Output Type	Output Frequency (MHz)	Output Voltage (V)	Output Skew (ps)	Additive Phase Jitter RMS (ps)	Package Type
5V41067A	2	HCSL	0 - 200	4	HCSL, LVDS	0 - 200	3.3	50	0.1	20-TSSOP
5V41068A	2	HCSL	0 - 200	1	HCSL, LVDS	0 - 200	3.3	N/A	0.1	16-TSSOP
8SLVP1212I	2	CML, LVDS, LVPECL	0 - 2000	12	LVPECL	0 - 2000	2.5, 3.3	15	0.045	40-VFOFN
83908-02	3	Crystal, LVCMOS	10 - 40	8	LVCMOS	10 - 40, 200	1.8, 2.5, 3.3	N/A	N/A	24-TSSOP
854S54I	3	LVDS, LVPECL	0 - 2500	3	LVDS	0 - 2500	2.5	N/A	0.045	16-VFOFPN
854S713I	3	CML, LVDS, LVPECL	0 - 3000	3	LVDS	0 - 3000	3.3	25	0.09	24-VFOFN
85357-01	4	LVDS, LVPECL, LVHSTL, SSTL, HCSL	0 - 750	1	LVPECL	0 - 750	3.3	N/A	N/A	20-TSSOP
859S0424I	4	CML, LVDS, LVPECL	0 - 3000	4	LVDS, LVPECL	0 - 3000	2.5, 3.3	25	0.22	24-TSSOP
83058I	8	LVCMOS	0 - 250	1	LVCMOS	0 - 250	1.8, 2.5, 3.3	N/A	0.14	16-TSSOP
853S058I	8	LVDS, LVPECL, SSTL	0 - 2500	1	LVPECL	0 - 2500	2.5, 3.3	N/A	0.075	24-TSSOP
850S1201I	12	LVCMOS	0 - 250	1	LVCMOS	0 - 250	2.5, 3.3	N/A	0.35	20-TSSOP
859S1601I	16	LVCMOS	0 - 250	1	LVDS, LVPECL	0 - 250	2.5, 3.3	2.5, 3.3	0.2	24-TSSOP

These products represent only a portion of IDT's Multiplexer and Fanout Multiplexer portfolio. For information on additional devices, please visit www.idt.com/timing/multiplexers

CLOCK GENERATORS, SYNTHESIZERS AND ZERO DELAY BUFFERS

Clock Generators, Synthesizers and Zero Delay Buffers	8
FemtoClock® Low Phase-Noise Frequency Synthesizers	10
VersaClock® III Programmable Clocks	12
VersaClock® LP Programmable Clocks	13
Spread-Spectrum Clocks	14



Clock Generators, Synthesizers and Zero Delay Buffers

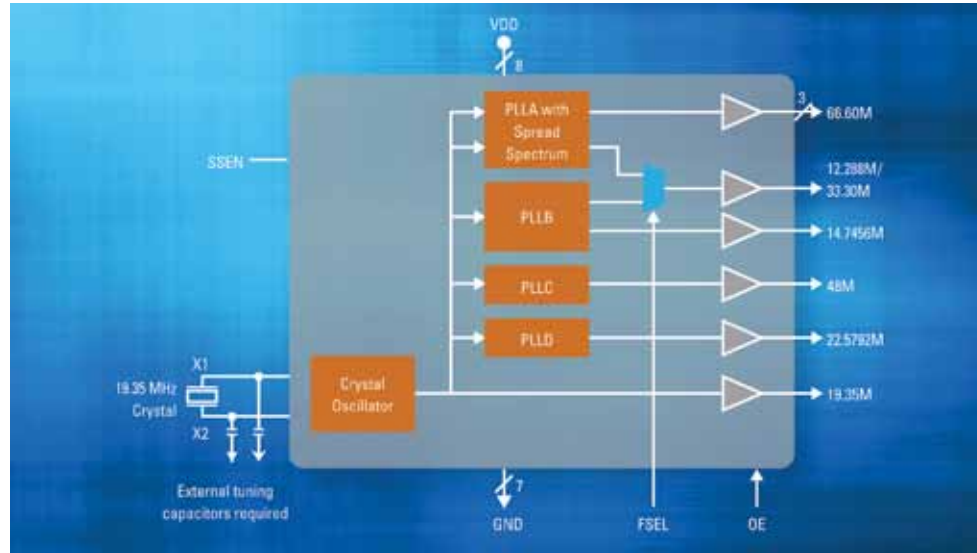

IDT clock generators are PLL-based products that generate different output frequencies from a common input frequency. Each peripheral in a system requires a different frequency to operate. IDT clock generators produce clock output frequencies within strict tolerances to the application they are sourcing. They use a simple, low cost, fundamental-mode quartz crystal or reference clock as the frequency reference, from which they generate low-jitter output clocks. Multiple copies of some frequencies may be provided to drive multiple loads. They also allow for frequency translation - either multiplication or division. IDT offers clock generators with both single ended and differential clock outputs. Some devices provide a programmable-skew feature allowing the user to adjust the timing of individual outputs. This provides flexibility for last minute clock skew management in the system. There are also devices available with an external feedback path, permitting precise control of clock signal timing to loads.

General purpose synthesizers are asynchronous clock sources with output frequencies readily selected with very high resolution (very small frequency steps). They use a simple, low cost, fundamental-mode quartz crystal as the frequency reference, from which they synthesize low-jitter output clocks. Allowing on-the-fly configuration of the output frequency through either a parallel or serial interface, these flexible synthesizers support many wide frequency, low jitter clocking applications. IDT synthesizers use a PLL architecture that simultaneously provides low jitter performance with a wide frequency range. Using silicon device integration techniques, they offer more functionality than fixed frequency oscillators.

Zero Delay Buffers are ideal for applications requiring synchronized clocking for FPGAs, CPUs, logic and synchronous memory. Zero-delay buffers are PLL-based devices that regenerate the input clock signal with fanout to drive multiple loads. Most devices allow the delay through the device to be adjusted through an external feedback path. This allows precise control of the timing of the clock signals to the loads. Zero-delay buffers provide a synchronous copy of the input clock at the outputs, usually without frequency translation. Simple frequency translation is possible when a single divider is used for all outputs, including feedback output, to maintain clock synchronization.

IDT's Clock generators, synthesizers and zero delay families are available in a wide range of versions. Differential outputs such as LVPECL, LVDS, HCSL, CML, HSTL, as well as selectable outputs, are supported for output frequencies up to 3.2 GHz and single-ended LVCMOS outputs for frequencies up to 350 MHz. IDT's PLL portfolio has devices supporting supply voltages from 1.2 V up to 3.3 V and that are available in the commercial and industrial temperature ranges.

FEATURES

- Devices with up to 21 outputs
- Single and Multiple frequency output devices available
- Differential outputs such as LVPECL, LVDS, HSTL and SSTL for frequencies up to 1.125 GHz
- Single ended LVCMOS outputs for frequencies up to 250 MHz
- Integrated fan-out
- Low cycle-to-cycle and period jitter
- Integer and fractional feedback architecture
- Available in multiple voltage ranges
- Synchronous copy of input to all outputs with minimal delay error
- Adjustability through external delay line
- Low Device-to-device skew <700 ps
- Full CMOS outputs with 25 mA output drive capability at TTL levels
- Industrial temperature range available

BENEFITS

- Improved reliability by reducing number of quartz crystals required on a board
- Reduces cost, BOM, and inventory by replacing multiple discrete devices with one IC
- Lower power consumption
- Tri-state mode for board-level testing available
- External feedback for delay adjustments

CLOCK GENERATORS AND SYNTHESIZERS

Part Number	# of Outputs	Output Type	Output Freq Range (MHz)	# of Output Banks	# of Inputs	Input Frequency (MHz)	Input Type	Output Skew (ps)	Phase Noise Typ RMS (ps)	Phase Noise Max RMS (ps)	Period Jitter Typ P-P (ps)	Output Voltage (V)	Package Type
501	1	LVC MOS	13 - 160	1	1	2 - 50	Crystal, LVC MOS	N/A	N/A	N/A	70	3.3, 5	8-TSSOP, 8-SOIC
511	1	LVC MOS	14 - 200	1	1	2 - 50	Crystal, LVC MOS	N/A	N/A	N/A	70	3.3, 5	8-SOIC
601-02	1	LVC MOS	13 - 170	1	1	10 - 27	Crystal, LVC MOS	N/A	N/A	N/A	50	2.5, 3.3	20-OSOP
502	2	LVC MOS	14 - 160	2	1	2 - 50	Crystal, LVC MOS	N/A	N/A	N/A	70	3.3, 5	8-SOIC
525-02	2	CMOS	1.5 - 250	2	1	2 - 50	Crystal, LVC MOS	N/A	N/A	N/A	85	3.3, 5	28-OSOP
512	2	CMOS	14 - 160	1	1	2 - 50	Crystal, LVC MOS	N/A	N/A	N/A	200	3 - 5.5	8-SOIC
514	2	CMOS	14 - 140	1	1	2 - 50	Crystal, LVC MOS	N/A	N/A	N/A	160	3.3 - 5.5	8-SOIC
661	2	LVC MOS	8.192 - 73.728	1	1	27	Crystal	N/A	N/A	N/A	175	1.8, 2.5, 3.3	16-TSSOP
MK2703	2	LVC MOS	8.792 - 27	1	1	27	Crystal	N/A	N/A	N/A	190	1.8, 2.5, 3.3	16-TSSOP
8430I-61	2	LVPECL	20.83 - 500	1	1	14 - 27	Crystal	15	N/A	N/A	N/A	2.5, 3.3	32-TOFP
525-03	2	LVC MOS, LVPECL	1 - 250	1	1	0.5 - 250	LVPECL	N/A	N/A	N/A	350	3.3, 5	28-SSOP
8342-101	2	LVPECL	25 - 700	1	1	40	LVPECL, LVDS, LVHSTL, SSTL, HC SL	15	N/A	5	N/A	3.3	32-TOFP
84321	2	LVPECL	103.3 - 260	1	1	14 - 40	Crystal	15	2.5	N/A	N/A	3.3	32-TOFP
844003I-02	3	LVDS	98 - 680	2	2	25, 26.04167, 31.25	Crystal, LVC MOS		0.5	0.34	N/A	3.3	32-VFOFPN
650-27	7	LVC MOS	8.333 - 666	2	2	12.5, 25	Crystal	N/A	N/A	N/A	150	3.3	20-OSOP
650-21	7	LVC MOS	12 - 100	2	1	25	Crystal, LVC MOS	N/A	N/A	N/A	N/A	3, 5.5	20-SSOP
8430S10I-03	10	LVC MOS, LVDS, LVPECL	25 - 133.333	6	2	25	Crystal, CML, LVC MOS, LVC MOS, LVDS, LVPECL, SSTL	25	0.557	N/A	N/A	2.5, 3.3	48-PTOFP
843207-350	7	LVPECL	87.5 - 175.35	7	2	12.4 - 15	Crystal, LVC MOS	3.3	N/A	1.48	N/A	3.3	48-TOFP

ZERO DELAY BUFFERS

Part Number	# of Outputs	Output Type	Output Freq Range (MHz)	# of Output Banks	# of Inputs	Input Frequency (MHz)	Input Type	Output Skew (ps)	C-C Jitter Max P-P (ps)	Output Voltage (V)	Package Type
87002-02	2	LVC MOS	15.625 - 250	1	1	15.625 - 250	HC SL, HSTL, LVDS, LVPECL, SSTL	35	45	2.5, 3.3	20-TSSOP
86004-01	4	LVC MOS	62.5 - 250	1	1	62.5 - 250	LVC MOS	55	45	2.5, 3.3	16-TSSOP
2305-1	5	LVC MOS	10 - 133	1	1	10 - 133	LVC MOS	250	200	3.3	8-TSSOP
23S05-1	5	LVC MOS	10 - 133	1	1	10 - 133	LVC MOS	250	200	3.3	8-SOIC
8634-01	5	LVPECL	31.25 - 700	1	2	31.25 - 700	HC SL, HSTL, LVDS, LVPECL, SSTL	25	25	3.3	32-TOFP
87931I-147	6	LVC MOS	0 - 240	3	2	0 - 240	LVC MOS, HSTL, LVDS, LVPECL, SSTL	165	45	3.3	32-LOFP
23S08-1	8	LVC MOS	10 - 133	2	1	10 - 133	LVC MOS	250	200	3.3	16-SOIC, 16-TSSOP
8752I	8	LVC MOS	18.33 - 240	2	2	18.33 - 240	LVC MOS	90	75	2.5, 3.3	32-TOFP
23S09-1	9	LVC MOS	10 - 133	2	1	10 - 133	LVC MOS	250	200	3.3	16-SOIC, 16-TSSOP
8624I	10	HSTL	31.25 - 700	5	2	31.25 - 700	HC SL, HSTL, LVDS, LVPECL, SSTL	25	25	2.5, 3.3	32-TOFP

These products represent only a portion of IDT's Clock Generator, Synthesizer and Zero Delay Buffer portfolio. For information on additional devices, please visit www.idt.com/timing/clock-gen

FemtoClock® Low Phase-Noise Frequency Synthesizers

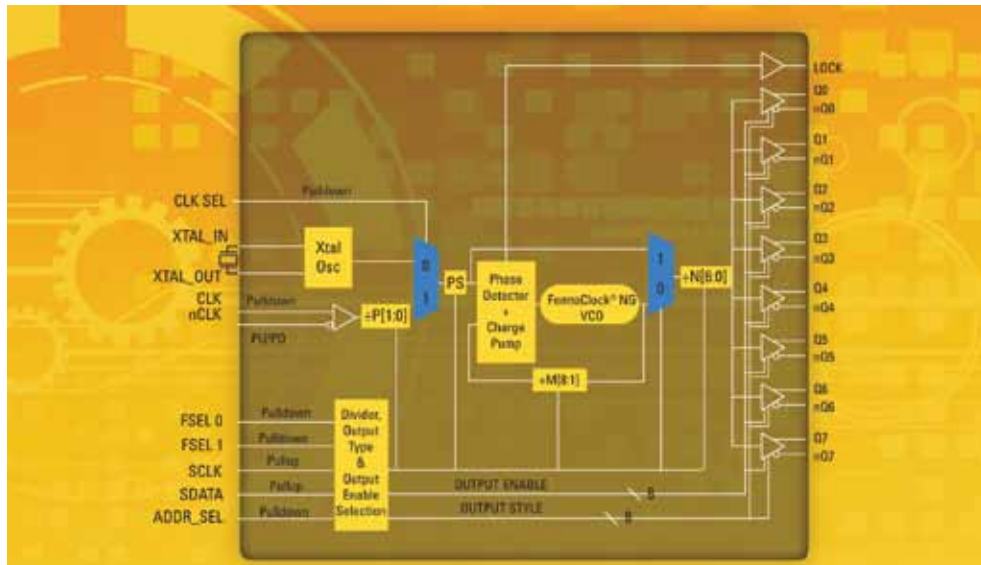

IDT FemtoClock® and FemtoClock Next Generation (NG) devices are advanced, high-performance clock-frequency synthesizers. Employing a simple, low cost, fundamental-mode quartz crystal as the low frequency reference these devices synthesize high quality clock signals with less than 0.5 ps of RMS phase noise, up to 1.3 GHz.

FemtoClock devices are fully customizable, stand-alone solutions that generate reference frequencies allowing them to replace crystal and SAW oscillators in high-performance applications. This family of devices is often used to replace third overtone and high frequency fundamental (HFF, inverted mesa) crystal oscillators or expensive surface acoustic wave (SAW) oscillators. They are more reliable, cost less, and are more readily available with shorter lead times.

Unlike fixed frequency oscillators, FemtoClocks are a frequency-synthesis technology capable of multiple clock frequencies and more flexibility in any application. Because FemtoClocks are silicon IC-based clock devices, additional clock tree functions unavailable in a single function fixed frequency oscillator can be integrated into a single device. The IDT FemtoClock family delivers a wide range of device packages and capabilities, starting with small 8-pin TSSOP devices that provide one clean, low jitter clock signal. Also available are devices with more integrated functions, multiple outputs, multiple frequencies and other more complex programmable synthesis functions.

These devices are designed to work in conjunction with other devices on the board that require a reference clock, such as PHYs, switches, ASICs and network processors and meet the specification requirements of many interface standards, such as 10 Gigabit Ethernet, PCI Express, Fibre Channel and SONET. While generally optimized for synthesizing reference clock frequencies commonly used in communication applications, there are also a variety of FemtoClock devices with frequencies useful for CPU, memory, logic and other general-purpose clocking applications, including:

- ASICs, DSPs, CPUs and memory
- Communication (including SONET/SDH and SPI4.2)
- Networking (including 1 Gb, 10 Gb, XAUI and 12 Gb Ethernet)
- PCI Express®
- SERDES and PHY Reference Clocks
- Serial Storage (SAS, SATA, Fibre Channel 4, 8 and 10 Gb)
- Wireless Infrastructure (including CPRI, RP3)

FEATURES

- Multi-output, multi-frequency, and multi-style product families
- Fully programmable clock sources
- Programmable crystal-oscillator and VCXO
- Multiple frequencies produced from a single device
- Spread spectrum clocking for EMI reduction
- <500 fs RMS phase noise jitter
- Improved power-supply noise rejection
- Up to four user defined, factory-programmed output frequencies stored within the device

BENEFITS

- Flexible frequency configurations solve complex design problems
- Configurable to output any clock rate using two-wire I²C serial interface
- Short lead times compared to traditional crystal oscillators
- Reduces overall component count and inventory management
- Dynamic frequency changes enable board and system test and diagnosis by clock frequency margining
- Lower cost than oscillators

FEMTOCLOCK DEVICES

Part Number	# of Outputs	Output Type	Output Freq Range (MHz)	Output Banks (#)	# of Inputs	Input Type	Input Frequency (MHz)	Output Voltage (V)	Output Skew (ps)	Phase Noise Typ RMS (ps)	Package Type
83PR2261-01	1	LVPECL	83.33-213.33	1	1	Crystal	15.625 - 32	2.5, 3.3	N/A	0.44	10-VFOFPN
843001	1	LVPECL	106.25, 187.5, 212.5	1	1	Crystal	23.4375, 26.5625	3.3	N/A	0.6	8-TSSOP, 16-TSSOP
843051	1	LVPECL	155.52, 156.25, 161.13	1	1	Crystal	12 - 40	3.3	N/A	0.43	8-TSSOP
874001I-05	1	LVDS	98-640	1	1	LVDS, LVPECL, LVHSTL, SSTL, HCSL	98 - 128	3.3	90	N/A	24-TSSOP
8430252I-45	2	LVC MOS, LVPECL	125, 156.25	2	1	Crystal	25	3.3	N/A	0.39	16-TSSOP
843003I-01	3	LVPECL	61.25-680	2	2	Crystal, LVC MOS	15.313 - 27.2	3.3	125	0.43	24-TSSOP
843034I-06	3	LVPECL	120 - 375	1	4	LVPECL, LVDS, LVHSTL, HCSL, SSTL	12 - 40	3.3	N/A	1.33	48-TOFP
871004I-04	4	HCSL	98-640	1	1	LVDS, LVPECL, LVHSTL, SSTL, HCSL	98 - 128	3.3	N/A	N/A	24-TSSOP
841604I	4	HCSL	100, 125	1	2	Crystal, LVC MOS	25	3.3	75	0.36	28-TSSOP
841664I	5	HCSL, LVC MOS	25, 125, 156.25	3	2	Crystal, LVC MOS	25	3.3	140	0.41	28-TSSOP
844256DI	6	LVDS	62.5-625	1	1	Crystal	15.625 - 25.5	2.5, 3.3	60	0.43	24-TSSOP
843207-350	7	LVPECL	87.5 - 175.35	7	2	Crystal, LVC MOS	12.4 - 15	3.3	N/A	1.48	48-TOFP
841608I	8	HCSL	100, 125	1	2	Crystal, LVC MOS	25	3.3	105	0.37	28-TSSOP
814S208I	9	LVDS	30.72, 122.88, 153.6	4	2	Crystal, LVPECL, LVDS, CML	30.72	1.8, 2.5, 3.3	100	0.642	48-VFOFPN
849S625I	10	LVDS, LVPECL	125, 156.25, 312.5, 625	3	2	Crystal, LVC MOS	25	3.3	N/A	0.373	48-TOFP

FEMTOCLOCK NG DEVICES

Generic	# of Outputs	Output Type	Output Frequency Range (MHz)	Output Banks (#)	# of Inputs	Input Type	Input Frequency (MHz)	Output Voltage (V)	Output Skew (ps)	Phase Noise Typ RMS (ps)	Package Type
83PN156I	1	LVPECL	100 - 156.25	1	1	Crystal, LVC MOS	20 - 25	2.5, 3.3	N/A	0.314	10-VFOFPN
83PN625I	1	LVPECL	156.25 - 625	1	1	Crystal	25	2.5, 3.3	N/A	0.3	10-VFOFPN
83PN187I	1	LVPECL	125 - 187.5	1	1	Crystal	25	2.5, 3.3	N/A	0.3	10-VFOFPN
843N252-45	2	LVC MOS, LVPECL	125, 156.25	2	1	Crystal	25	3.3	N/A	0.33	16-TSSOP
843N3960I	2	LVPECL	100, 125, 156.25, 212.5	1	2	Crystal, LVPECL, LVDS, HCSL	25	3.3	50	0.5	20-TSSOP
841N254I	4	LVDS, HCSL	100, 125, 156.25, 250	1	2	Crystal, LVC MOS	25	2.5, 3.3	2700	0.27	32-VFOFPN
8T49N004I	4	LVDS, LVPECL	15.16 - 1250	1	2	Crystal, LVPECL, LVDS, HCSL	10 - 312.5	2.5, 3.3	45	0.05	32-VFOFPN
849N2505I	5	LVDS, LVPECL	25, 50, 125, 156.25	1	1	LVDS, LVPECL	10	3.3	N/A	0.336	32-VFOFPN
8T49N008I	8	LVDS, LVPECL	15.16 - 1250	1	2	Crystal, LVPECL, LVDS, HCSL	10 - 312.5	2.5, 3.3	50	0.05	40-VFOFPN
843N571I	10	LVC MOS, LVPECL	25 - 156.25	5	2	Crystal, LVC MOS	25	3.3	40	0.212	40-VFOFPN

These products represent only a portion of IDT's FemtoClock portfolio. For information on additional devices, please visit www.idt.com/timing/femtoclock

VersaClock® III Programmable Clocks

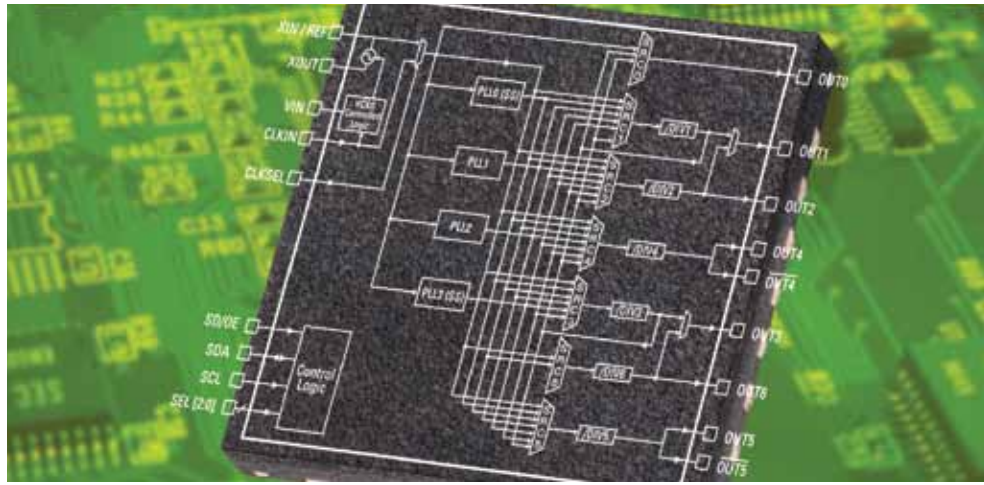

VersaClock® III products allow designers to save board space and cost by replacing crystals, oscillators and buffers with a single timing device. Exceptional versatility and configurability allow for maximum freedom in the design process.

There are four internal PLLs, each individually programmable, allowing for up to seven unique frequencies. These frequencies are generated from a single reference clock, which can come from one of two redundant clock inputs. A glitchless automatic or manual switchover function allows the redundant clock to be selected during normal operation.

VersaClock devices are highly configurable and can be programmed through the use of the I²C interface. The programming interface enables the device to be programmed when it is in normal operation. An internal EEPROM allows the user to save and restore the configuration of the device without having to reprogram it on power-up.

FEATURES

- 3.3V device with up to four independently controlled VDDO (1.8V - 3.3V)
- Two of four integrated PLLs support spread spectrum generation for EMI reduction
- Integrated VCXO
- Output frequency range: 4.9 kHz to 500 MHz
 - 1.8 - 3.3 V LVTTTL/ LVCMOS, LVPECL, LVDS and HCSSL
- Programmable loop bandwidth
- Programmable slew rate control
- Redundant clock inputs with glitchless auto and manual switchover options
- Small 4x4mm and 5x5mm QFN and TSSOP packages
- Spread spectrum for EMI reduction

BENEFITS

- Small footprint saves board space
- Reduces Cost, BOM and inventory by replacing multiple crystals, oscillators and buffers
- Flexible devices for high performance clocking applications
- Integrated EEPROM for easy re-programming if frequency requirements change

Part Number	# of Outputs	Output Type	Output Freq Range (MHz)	# of Output Banks	Core Voltage (V)	Output Voltage (V)	Output Skew (ps)	Period Jitter Typ P-P (ps)	Prog. Interface	Functionality	Package Type
5V19EE403	4	LVCMOS	0.001 - 200	4	3.3	3.3	75	80	I ² C, EEPROM	VersaClock III VCXO	24-VFQFPN
5V49EE501	5	LVCMOS, LVPECL, LVDS, HCSSL	0.001 - 200	5	3.3	3.3	75	60	I ² C, EEPROM	VersaClock III XO	24-VFQFPN
5V49EE502	5	LVCMOS, LVPECL, LVDS, HCSSL	0.001 - 200	5	3.3	1.8, 3.3	75	60	I ² C, EEPROM	VersaClock III XO	24-VFQFPN
5V49EE503	5	LVCMOS	0.001 - 200	5	3.3	3.3	75	80	I ² C, EEPROM	VersaClock III XO	24-VFQFPN
5V49EE504	5	LVCMOS	0.001 - 200	5	3.3	1.8, 3.3	75	80	I ² C, EEPROM	VersaClock III XO	24-VFQFPN
5V19EE604	6	LVCMOS	0.001 - 200	5	3.3	1.8, 3.3	75	80	I ² C, EEPROM	VersaClock III VCXO	28-VFQFPN
5V49EE704	7	LVCMOS	0.001 - 200	6	3.3	1.8, 3.3	75	80	I ² C, EEPROM	VersaClock III XO	28-VFQFPN
5V19EE904	9	LVCMOS	0.001 - 200	7	3.3	1.8, 3.3	75	80	I ² C, EEPROM	VersaClock III VCXO	32-VFQFPN
5V49EE901	9	LVCMOS, LVPECL, LVDS, HCSSL	0.001 - 200	7	3.3	3.3	75	60	I ² C, EEPROM	VersaClock III XO	32-VFQFPN, 28-TSSOP
5V49EE902	9	LVCMOS, LVPECL, LVDS, HCSSL	0.001 - 200	7	3.3	1.8, 3.3	75	60	I ² C, EEPROM	VersaClock III XO	32-VFQFPN
5V49EE904	9	LVCMOS	0.001 - 200	7	3.3	1.8, 3.3	75	80	I ² C, EEPROM	VersaClock III XO	32-VFQFPN
5V19EE901	9	LVCMOS, LVPECL, LVDS, HCSSL	0.001 - 200	7	3.3	3.3	75	60	I ² C, EEPROM	VersaClock III VCXO	32-VFQFPN, 28-TSSOP

These products represent only a portion of IDT's VersaClock III portfolio. For information on additional devices, please visit www.idt.com/timing/versaclock

VersaClock® LP Programmable Clocks

FEATURES

- Low Power PLLs
 - 4-8mW per clock output
 - 20µW in power down mode
 - 200µW power down with 32.768kHz active
- Supports clock input or crystal input
- 32.768kHz clock support
- Spread spectrum for EMI reduction
 - Unique video spread capability
- Small 3x3 and 4x4 QFN package
- Synthesizes kHz to 120Mhz outputs
- Less than 100ps (pico seconds) period jitter (typical)
- 1.8-3.3V LVTTTL or LVDS outputs

BENEFITS

- Small footprint saves board space
- Reduces system power consumption
- Reduces Cost, BOM and inventory by replacing multiple crystals, oscillators and buffers
- Flexible devices for battery-powered applications
- Integrated EEPROM for easy re-programming if frequency requirements change

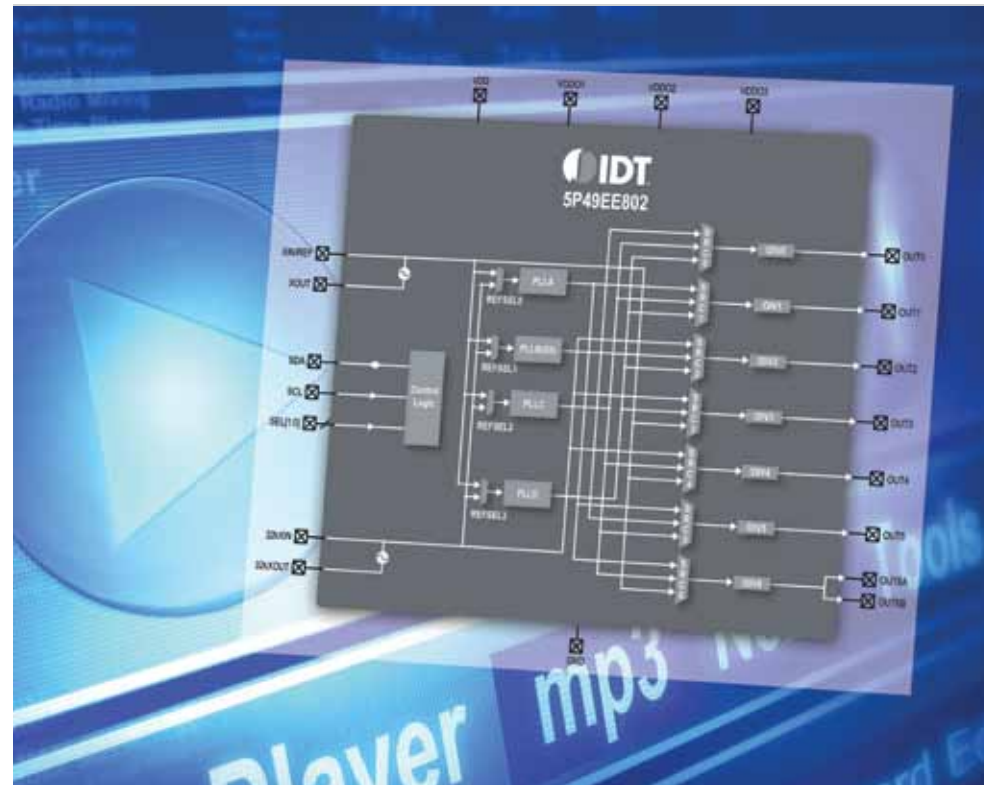

VersaClock® LP products allow the designer to save board space, power consumption and cost by replacing crystals, oscillators and buffers with a single timing device. Exceptional versatility and configurability allow for maximum freedom in the design process.

There are four internal PLLs, each individually programmable, allowing for up to eight unique frequencies. The frequencies are generated from a single reference clock or crystal.

VersaClock devices can be programmed through the use of the I²C interfaces, which enables the device to be programmed when it is in normal operation. An internal EEPROM allows the user to save and restore the configuration of the device without having to reprogram it on power-up. VersaClock LP products from IDT provide an almost universal solution for a variety of high performance clock applications.

Part Number	# of Outputs	Output Type	Output Freq Range (MHz)	Input Frequency (MHz)	# of Inputs	# of Output Banks	Core Voltage (V)	Output Voltage (V)	Output Skew (ps)	Prog. Interface	Package Type
5P49EE601	6	LVC MOS, LVDS	0.001 - 150	1 - 40	2	5	1.8	1.8, 2.5, 3.3	200	I ² C, EEPROM	24-VFOFPN
5P49EE602	6	LVC MOS	0.001 - 120	1 - 40	2	5	1.8	1.8, 2.5, 3.3	75	I ² C, EEPROM	24-VFOFPN
5P49EE801	8	LVC MOS, LVDS	0.001 - 150	1 - 40	2	7	1.8	1.8, 2.5, 3.3	75	I ² C, EEPROM	28-VFOFPN
5P49EE802	8	LVC MOS	0.001 - 120	1 - 40	2	7	1.8	1.8, 2.5, 3.3	75	I ² C, EEPROM	28-VFOFPN

These products represent only a portion of IDT's VersaClock LP portfolio. For information on additional devices, please visit www.idt.com/timing/versaclock

Spread Spectrum Clocks



Electromagnetic Interference (EMI) is a major challenge for designers of electronic devices. Frequency references, whether crystal oscillators or silicon based PLLs, can be a major source of EMI on circuit boards. Spread spectrum is a technique where the output frequency is modulated slightly to lower the peak energy generated by a clock. Using spread spectrum lowers clock generated EMI from both the fundamental frequency and subsequent harmonics, thereby reducing the total system EMI.

IDT's spread products support two different types of spread spectrum: down spread and center spread. Center spread modulates evenly around the clock frequency while down spread modulates below the clock frequency. The type of spread used depends on the specifications of the clock destination. Some destination chipsets, CPU's, etc have a maximum clock frequency specification that cannot be violated. In these cases, down spread should be applied.

IDT's spread portfolio has products supporting crystal or clock reference inputs. For systems requiring spread injection on clock reference inputs, IDT's high performance PLL technology maintains good phase noise and high performance while reducing EMI. By using IDT's spread spectrum technology, customers maintain high performance while saving cost and design time on expensive shielding, chokes and ferrite beads.

FEATURES

- Accepts a clock input and provides same frequency dithered output
- Center and down spread option available
- Low additive cycle to cycle jitter
- Peak reduction by 7dB - 14dB typical on 3rd - 19th odd harmonics
- Wide input frequency ranges available
- Available in many small packages minimizing board space

BENEFITS

- Reduces EMI on boards
- Reduces cost, BOM and inventory
- Good phase noise and high performance clocks

Part Number	# of Outputs	Output Type	Output Freq Range (MHz)	Input Frequency (MHz)	# of Inputs	Input Type	Output Voltage (V)	Modulation Rate	Spread Amount (%)	C-C Jitter Max P-P (ps)	Package Type
5P50901	1	LVC MOS	10 - 25	10 - 25	1	LVC MOS	1.8, 2.5, 3.3	ICLK*27/10000	Center 0.25, 0.5, 1.0, 1.5, 2.0; Down -0.5, -1.0	150 (typ)	8-DFN 8-MSOP
5P50902	1	LVC MOS	20 - 50	20 - 50	1	LVC MOS	1.8, 2.5, 3.3	ICLK*27/20000	Center 0.25, 0.5, 1.0, 1.5, 2.0; Down -0.5, -1.0	150 (typ)	8-DFN 8-MSOP
5P50903	1	LVC MOS	40 - 100	40 - 100	1	LVC MOS	1.8, 2.5, 3.3	ICLK*27/40000	Center 0.25, 0.5, 1.0, 1.5, 2.0; Down -0.5, -1.0	150 (typ)	8-DFN 8-MSOP
5P50904	1	LVC MOS	80 - 170	80 - 170	1	LVC MOS	1.8, 2.5, 3.3	ICLK*27/80000	Center 0.25, 0.5, 1.0, 1.5, 2.0; Down -0.5, -1.0	150 (typ)	8-DFN 8-MSOP
5P50911	1	LVC MOS	5 - 15	10 - 30	1	Crystal	1.8, 2.5, 3.3	ICLK*27/10000	Center 0.5, 1.5; Down -0.5	150 (typ)	8-DFN 8-MSOP
5P50912	1	LVC MOS	10 - 30	10 - 30	1	Crystal	1.8, 2.5, 3.3	ICLK*27/10000	Center 0.5, 1.5; Down -0.5	150 (typ)	8-DFN 8-MSOP
5P50913	1	LVC MOS	20 - 60	10 - 30	1	Crystal	1.8, 2.5, 3.3	ICLK*27/10000	Center 0.5, 1.5; Down -0.5	150 (typ)	8-DFN 8-MSOP
5P50914	1	LVC MOS	40 - 120	10 - 30	1	Crystal	1.8, 2.5, 3.3	ICLK*27/10000	Center 0.5, 1.5; Down -0.5	150 (typ)	8-DFN 8-MSOP
7152	1	LVC MOS	16 - 134	16.6 - 134	1	LVC MOS	3.3	33 kHz	Center 0.5, 1.5; Down -0.5	150	8-SOIC
5V50015	1	LVC MOS	135 - 200	135 - 200	1	LVC MOS	3.3	32kHz @ 130Mh	Center 0.5, 1.0, 1.5, 2.0	100	8-SOIC, 8-TSSOP
5V50017	1	LVC MOS	15 - 60	15 - 60	1	LVC MOS	3.3	32kHz @ 20Mhz	Down -1.0, -2.0, -3.0	100	8-SOIC
841S041	4	HCSL	100	25	1	Crystal	3.3	32 kHz	Down -0.35, -0.5	35	24-TSSOP
8414841	5	HCSL, LVC MOS	25, 100, 125, 200, 400	25	2	Crystal, LVC MOS	3.3	32 kHz	Down -0.5	36	32-VQFN

These products represent only a portion of IDT's Spread Spectrum portfolio. For information on additional devices, please visit www.idt.com/timing/spread-spectrum

JITTER ATTENUATION AND FREQUENCY TRANSLATION

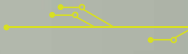

Universal Frequency Translators (UFT)	16
VCXO PLL Jitter Attenuators	17
VCXO PLL Jitter Attenuator Modules	18



Universal Frequency Translators (UFT)

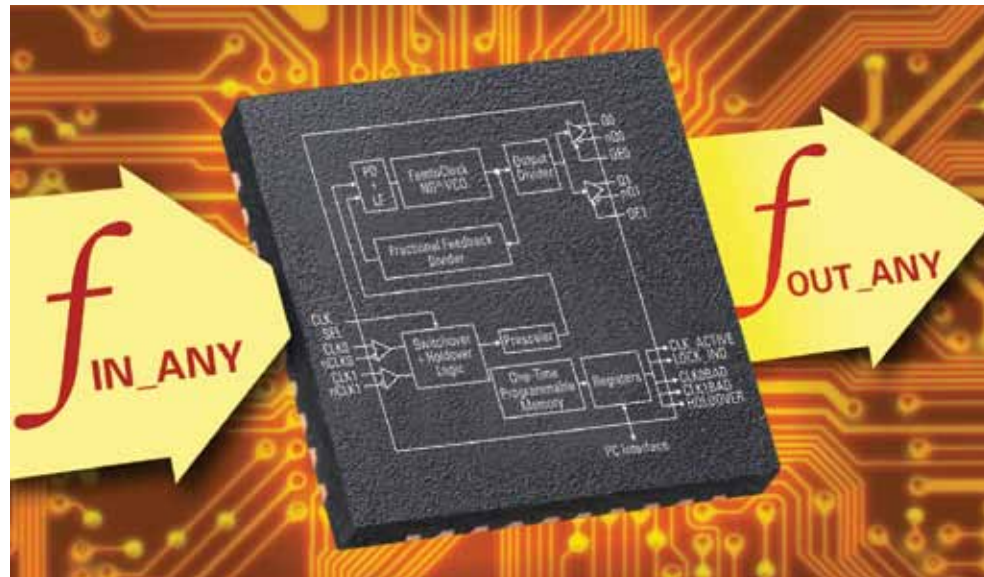

IDT FemtoClock® NG Universal Frequency Translators (UFT) cover all your frequency synthesis and translation needs. Family members are available that support 1, 2, 3 or 4 PLL's in a single package.

As a frequency synthesizer, a low-cost, readily-available fundamental mode crystal can be used to generate output frequencies that range from 1MHz to 1.3GHz. The internal architecture of the device allows any frequency of crystal from 16MHz to 40MHz to be used regardless of the frequency desired.

As a frequency translator, this family of devices accepts 1 or 2 input reference clocks per PLL from 8 kHz to 710 MHz, switching between them as necessary and generates any output frequency from 1 MHz to 1.3 GHz with no frequency translation error in most cases.

Family members support either one or two different pin-selectable configurations per PLL that may be pre-loaded into the internal One-Time Programmable (OTP) non-volatile memory for automatic operation directly from powerup, or an I2C serial interface can be used to set the desired configurations.

In addition to a crystal input, the UFT features up to two clock inputs per PLL and provides up to two outputs per PLL. Each output is individually programmable as LVPECL or LVDS. Versions of the UFT with single-ended outputs are also available. Selection between the two input references per PLL may be performed manually via either pin or register, or it may be performed automatically with revertive or non-revertive recovery.

FEATURES

- Input frequency range: 8 kHz to 710 MHz
- Output frequency range: 1 MHz to 1300 MHz
- Frequency synthesis
- High-bandwidth frequency translation
- Low-bandwidth frequency translation and jitter attenuation
- Each PLL has up to two outputs, LVPEL or LVDS level. Single-ended is also available.
- Industrial temperature range
- Up to 4 independent PLL
- Hitless Switching

BENEFITS

- Fully programmable clock source adds flexibility to the design cycle
- Two clock inputs with automatic hitless switching
- On-die non-volatile memory allows device to be fully functional at power-up without requiring complicated user programming
- Very low RMS jitter on all outputs for high-end communication applications

Part Number	# of Outputs	Output Type	Output Frequency Range (MHz)	# of Output Banks	# of Inputs	Input Type	Input Frequency (MHz)	Output Voltage (V)	Output Skew (ps)	Phase Noise Typ RMS (ps)	Package Type
8T49N222I	2	LVC MOS, LVDS, LVPECL	7.68 - 1200	1	3	Crystal, LVPECL, LVDS, HSTL, HCSL	0.008 - 710	2.5, 3.3	N/A	0.314	48-VFOFPN
8T49N203I	2	LVDS, LVPECL	0.98 - 1300	1	3	Crystal, LVPECL, LVDS, HSTL, HCSL	0.008 - 710	2.5, 3.3	42	0.285	40-VFOFPN
840N202I	2	LVC MOS	0.98 - 250	1	3	Crystal, LVPECL, LVDS, HSTL, HCSL	0.008 - 710	2.5, 3.3	25	0.5	40-VFOFPN
849N202I	2	LVC MOS, LVDS, LVPECL	0.98 - 1300	1	3	Crystal, LVPECL, LVDS, HSTL, HCSL	0.008 - 710	2.5, 3.3	30	0.301	40-VFOFPN
849N212I	2	LVDS, LVPECL, LVC MOS	0.98 - 250	1	3	Crystal, LVPECL, LVDS, HSTL, HCSL	0.008 - 710	2.5, 3.3	1000	0.388	40-VFOFPN

For additional information, please visit www.idt.com/timing/uft

VCXO PLL Jitter Attenuators

FEATURES

- Excellent jitter attenuation and frequency translation for synchronous clocking
- Output Frequency range from 15.476MHz – 1.3GHz
- Clock recovery
- 2:1 Input MUX for input reference clocks
- Single and multiple frequencies, tunable by a VIN control pin
- No switching glitches on output
- Multiple frequency pullability ranges, using recommended crystal
- Industrial temperature range
- Low power CMOS technology
- PLL filters input jitter while locking to the input reference
- Very low phase noise <0.7ps RMS

BENEFITS

- PLL filters input jitter while locking to the input reference
- Lower cost and shorter lead time than oscillators
- Reduced part count leads to cost, BOM and inventory reduction
- Straightforward programmability through Versaclock Software

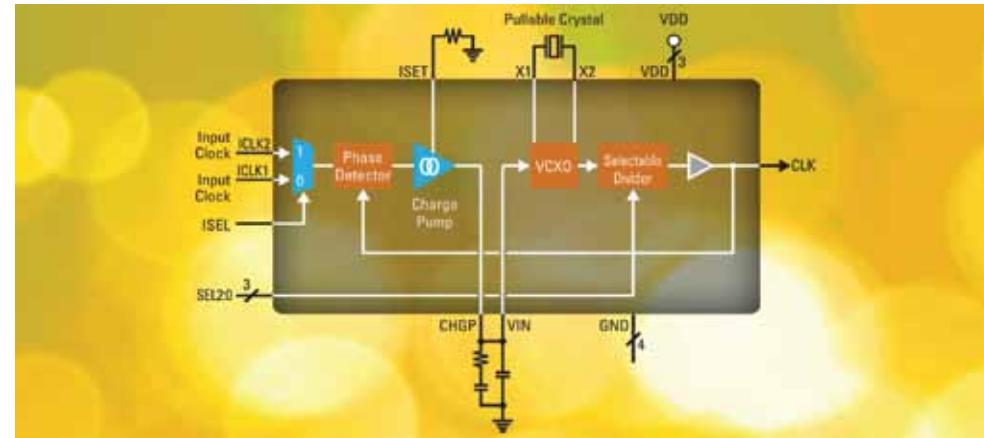

IDT voltage-controlled crystal oscillator (VCXO) jitter attenuator devices are synchronous jitter attenuation and frequency translation products featuring a VCXO-based PLL stage with either internal VCXO requiring only an external pullable crystal, or with an external low frequency VCXO. This PLL stage is typically configured with low loop bandwidth to provide jitter attenuation. It can also accommodate numerous pre, feedback, and output divider combinations to allow for frequency translation. The output frequency from the VCXO PLL stage is then followed by a frequency multiplier.

Some products use IDT’s FemtoClock® or FemtoClock NG technology for frequency multiplication. FemtoClock NG devices use a fixed crystal and perform the frequency pulling digitally using DPLL technology. The FemtoClock versions provide the capability to generate output frequencies up to 800 MHz with typical random phase-noise jitter of 1 ps RMS, while the NG versions have a maximum output frequency of up to 1.3GHz and a typical random phase-noise jitter of less than 0.7 ps RMS.

Part Number	# of Outputs	Output Type	Output Frequency Range (MHz)	# of Output Banks	# of Inputs	Input Type	Input Frequency (MHz)	Output Voltage (V)	Output Skew (ps)	Phase Noise Typ RMS (ps)	Package Type
2059-02	1	LVC MOS	10.368, 19.44, 27	1	2	LVC MOS	0.008, 0.015625, 0.015734265, 0.151875, 27	3.3	N/A	N/A	16-TSSOP
810251I	1	LVC MOS	25	1	1	LVC MOS	25, 125	2.5, 3.3	N/A	0.22	16-TSSOP
MK2058-01	1	LVC MOS	0.0033 - 27	1	2	LVC MOS	0.0033 - 27	3.3	N/A	N/A	20-SOIC
810251I-01	2	LVC MOS	0.008, 19.44, 25	2	1	LVC MOS	19.44, 25	3.3	N/A	N/A	16-TSSOP
810252DI-02	2	LVC MOS	25 - 312.5	2	2	LVPECL, LVDS, HSTL, SSTL, HCSL	0.008 - 155.52	3.3	200	1.05	32-VFQFPN
810N322I-02	2	LVC MOS	19.44 - 622.08	2	2	LVPECL, LVDS, HSTL, HCSL	0.008 - 156.25	3.3	80	0.624	32-VFQFPN
843002I-41	2	LVPECL	19.44, 77.76, 155.52, 311.04, 622.08	2	2	LVDS, LVPECL, HSTL, HCSL, SSTL, LVC MOS	19.44, 38.88, 77.76, 155.52, 311.04, 622.08	2.5, 3.3	150	0.81	32-VFQFPN
843002I-72	2	LVPECL	122.88	1	2	Crystal, LVC MOS	3.84, 19.2	2.5, 3.3	50	0.49	32-VFQFPN
8V89308I	2	LVPECL	25 - 156.25	2	1	LVPECL, LVDS	0.008 - 155.52	3.3	25	0.223	32-VFQFPN
813323	3	LVPECL	19.44, 77.76, 155.52, 622.08	1	1	LVPECL, LVDS, HSTL, SSTL, HCSL	19.44, 77.76, 155.52, 622.08	2.5, 3.3	50	1.4	24-TSSOP
814253	3	LVDS	19.6 - 27.2, 98 - 170, 245 - 340	1	1	LVPECL, LVDS, HSTL, HCSL	19.6 - 27.2, 49 - 68, 78.4 - 136	2.5, 3.3	40	0.405	24-TSSOP
843002-31	4	LVC MOS, LVPECL	1.1875 - 700	4	3	LVDS, LVPECL, HSTL, HCSL, SSTL, LVC MOS	0.008 - 622.08	3.3	N/A	N/A	64-TOFP
814075I	5	LVDS	12.288 - 614.4	2	2	LVDS, LVPECL, HSTL, HCSL, SSTL, LVC MOS	30.72 - 153.6	3.3	20	1.4	48-PTOFP
813078I	9	LVPECL	30.72, 38.4, 61.44, 76.8, 98.304, 122.88, 153.6, 245.76, 307.2, 491.52, 614.4	3	2	LVDS, LVPECL, HSTL	10, 12.88, 15, 15.36, 20, 30.72, 61.44, 122.88	3.3	200	0.92	64-TOFP

These products represent only a portion of IDT’s VCXO PLL Jitter Attenuator portfolio. For information on additional devices, please visit www.idt.com/timing/vcxo

VCSO PLL Jitter Attenuator Modules

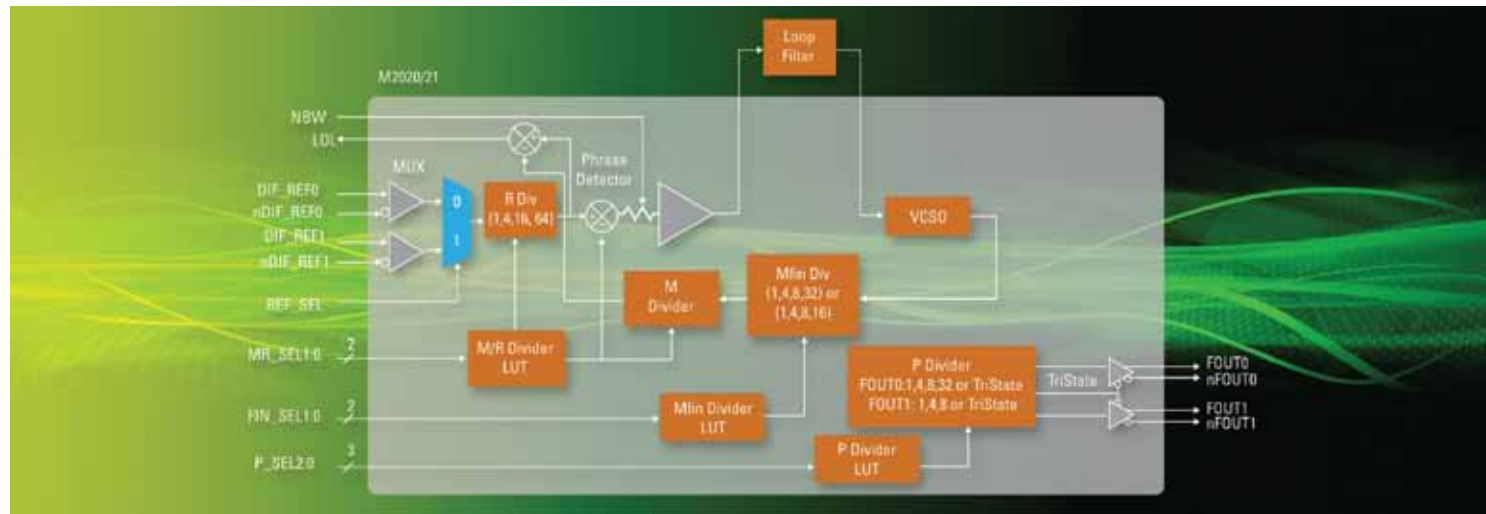

IDT VCSO PLL modules provide low noise jitter for optical networking and clock generation applications. The M900, M1000 and M2000 families of voltage-controlled SAW oscillator (VCSO) PLL modules combine an IDT custom IC and an IDT high-Q quartz surface acoustic wave (SAW) delay line in a 9mm x 9mm, hermetically sealed ceramic surface mount package. This provides a high performance, feature-rich solution that easily meets the ultra-low phase noise and jitter requirements of telecom and optical networking systems.

Each part number incorporates additional features such as phase build-out, hitless-switching, auto-switch, and simplified divider programming with FEC and DFEC look-up tables, and multiple outputs with programmable dividers to address the particular needs of the communications applications.

FEATURES

- Single and multiple frequencies, tunable by VIN control pin
- Jitter attenuation and frequency translation
- Output frequencies up to 3 GHz

BENEFITS

- Better close-in phase noise than traditional crystal oscillators
- RMS phase noise performance that exceeds OC-192 standards

Part Number	# of Outputs	Output Type	Output Frequency (MHz)	# of Output Banks	Input Frequency (MHz)	# of Inputs	Input Type	Core Voltage	Output Voltage	Phase Noise Typ. RMS (ps)	Package Type
M2004-02	1	LVPECL	50, 100, 200, 400	1	1 - 175	2	LVC MOS, LVPECL, LVDS	3.3	3.3	0.5	36-CLCC
M1020	2	LVPECL	19.44, 77.76, 155.52	1	15 - 700	2	LVC MOS, LVPECL, LVDS	3.3	3.3	0.4	36-CLCC
M2004-01	2	LVPECL	77.76, 155.52, 311.04, 622.08	1	1 - 175	2	LVC MOS	3.3	3.3	0.5	36-CLCC
M2006-02	2	LVPECL	19.44, 77.76, 155.52, 622.08	2	10 - 700	2	LVC MOS, LVPECL, LVDS	3.3	3.3	0.5	36-CLCC
M2020	2	LVPECL	19.44, 77.76, 155.52, 622.08	2	10 - 700	2	LVC MOS, LVPECL, LVDS	3.3	3.3	0.25	36-CLCC
M2050	2	LVPECL	25.781252, 128.90626, 161.132825, 644.5313	1	10 - 700	2	LVC MOS, LVPECL, LVDS	3.3	3.3	0.25	36-CLCC
M2061	2	LVPECL	19.44, 77.76, 155.52, 622.08	2	10 - 700	2	LVC MOS, LVPECL, LVDS	3.3	3.3	0.25	36-CLCC
M2065	2	LVPECL	41.8329125, 83.665825, 167.33165, 669.3266	2	10 - 700	2	LVC MOS, LVPECL, LVDS	3.3	3.3	0.25	36-CLCC
M902-01	2	LVPECL	156.25	1	25	1	Crystal, LVC MOS	3.3	3.3	0.5	36-CLCC
M2006-03	4	LVPECL	491.52	3	2.048, 4.096, 10.24, 20.48	2	LVC MOS	3.3	3.3	3	36-CLCC
M906-01	6	LVPECL	125	1	25	1	Crystal, LVC MOS	3.3	3.3	0.7	36-CLCC
M908-01	8	LVPECL	156.25	1	25	1	Crystal, LVC MOS	3.3	3.3	0.7	36-CLCC

These products represent only a portion of IDT's VCSO PLL Jitter Attenuator module portfolio. For information on additional devices, please visit www.idt.com/timing/vcso

NETWORK SYNCHRONIZATION WAN-PLL

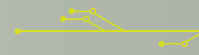

PDH and SONET/SDH	20
Synchronous Ethernet and IEEE 1588	21



PDH and SONET/SDH

IDT's WAN (Wide Area Network) PLLs are designed for synchronization of PDH, SONET/SDH and TDM equipment and interfaces. These devices comply with ITU-T recommendations for SECs (SDH Equipment Clocks); as well as Telcordia and ATIS/ANSI requirements for stratum 4, stratum 4E, stratum 3 and SONET minimum clock. IDT WAN PLLs provide functions such as selectable loop filters, holdover, hitless reference switching, phase slope limiting and clock redundancy.

FEATURES

- Compliance with Synchronous Ethernet, Stratum Level 2, 3, SMC, 4E and 4 timing requirements
- Jitter attenuation using internal analog PLL

BENEFITS

- Simplifies Synchronous Ethernet and Stratum compliant clock systems design
- Clock generation for IEEE-1588

- Monolithic solution for network synchronization in access, metro and core equipment
- Field proven to meet equipment standards from Telcordia, ITU and others
- Master/slaves support enhances high availability systems with failover
- Broad family of devices with software compatibility enhances design portability
- Offloads critical system processors tasks such as automatic switching of revertive clock input

Part Number	# of Outputs	Output Type	Output Freq Range (MHz)	Input Frequency (MHz)	# of Inputs	Input Type	# of Output Banks	Core Voltage (V)	Output Voltage (V)	Output Skew (ps)	Phase Noise Typ RMS (ps)	Phase Noise Max RMS (ps)	App Jitter Compliance	Package Type
82V32021	2	LVC MOS	0.000001 - 155.52	0.002 - 155.52	4	LVC MOS	2	3.3	3.3	N/A	<100	N/A	GR-1244-CORE, GR-253-CORE, ITU-T G.812, ITU-T G.813, ITU-T G.783, Stratum 4E and 4 clocks	68-VFOFPN
82V3202	3	LVC MOS, LVDS, LVPECL	0.000001 - 622.08	0.002 - 155.52	4	LVC MOS	3	3.3	3.3	50	<100	N/A	GR-1244-CORE, GR-253-CORE, ITU-T G.812, ITU-T G.813, ITU-T G.783, Stratum 3, SMC, Stratum 4E and 4 clocks	68-VFOFPN
82V3203B	4	LVC MOS, LVDS, LVPECL	0.000001 - 622.08	0.002 - 622.08	6	LVC MOS	4	3.3	3.3	50	<100	N/A	GR-1244-CORE, GR-253-CORE, ITU-T G.812, ITU-T G.813, ITU-T G.783, Stratum 3, SMC, Stratum 4E and 4 clocks	68-VFOFPN
82V3255	4	LVC MOS, LVDS, LVPECL	0.000001 - 622.08	0.002 - 622.08	8	LVPECL, LVDS, LVC MOS	4	3.3	3.3	50	<100	N/A	GR-1244-CORE, GR-253-CORE, ITU-T G.812, ITU-T G.813, ITU-T G.783, Stratum 3, SMC, Stratum 4E and 4 clocks	64-LOFP, 64-TOFP
82V3285A	7	LVPECL, LVDS, LVC MOS	0.000001 - 622.08	0.002 - 622.08	6	LVPECL, LVDS, LVC MOS	7	3.3	3.3	50	<100	N/A	GR-1244-CORE, GR-253-CORE, GR-1377-CORE, ITU G.812, ITU G.813, ITU G.783 ITU-T G.813 (STM-16/Option 1)	100-TOFP
82V3280	11	AMI, LVC MOS, LVDS, LVPECL	0.000001 - 622.08	0.002 - 622.08	15	AMI, LVPECL, LVDS, LVC MOS	11	3.3	3.3	50	<100	N/A	GR-1244-CORE, GR-253-CORE, ITU-T G.812, ITU-T G.813, ITU-T G.783, Stratum 3, SMC, Stratum 4E and 4 clocks	100-TOFP
82V3002A	12	LVC MOS	0.008, 1.544, 2.048, 3.088, 4.096, 6.312, 8.192, 16.384, 19.44, 32.768	0.008, 1.544, 2.048	2	LVC MOS	12	3.3	3.3	N/A	N/A	N/A	TR62411, GR-1244-CORE, ETS 300 011, ITU-T G.813 (Option 1), ITU-T G.812	56-SSOP
82V3288	13	AMI, LVPECL, LVDS, LVC MOS	0.000001 - 622.08	0.002 - 622.08	17	AMI, LVPECL, LVDS, LVC MOS	13	3.3	3.3	50	<100	N/A	GR-1244-CORE, GR-253-CORE, GR-1377-CORE, ITU G.812, ITU G.813, ITU G.783 ITU-T G.813 (STM-16/Option 1)	208-CABGA
82V3011	16	LVC MOS, LVDS	0.008, 1.544, 2.048, 3.088, 4.096, 6.312, 8.192, 16.384, 19.44, 32.768	0.008, 1.544, 2.048, 19.44	1	LVC MOS	17	3.3	3.3	N/A	N/A	N/A	TR62411, GR-1244-CORE, ETS 300 011, Stratum 4	56-SSOP
82V3012	16	LVC MOS, LVDS	0.008, 1.544, 2.048, 3.088, 4.096, 6.312, 8.192, 16.384, 19.44, 32.768	0.008, 1.544, 2.048, 19.44	2	LVC MOS	17	3.3	3.3	N/A	N/A	N/A	TR62411, GR-1244-CORE, ETS 300 011, ITU-T G.813 (Option 1), ITU-T G.812, Stratum 4	56-SSOP
82V3155	16	LVC MOS, LVDS	0.008, 1.544, 2.048, 3.088, 4.096, 6.312, 8.192, 16.384, 19.44, 32.768	0.008, 1.544, 2.048, 19.44	2	LVC MOS	17	3.3	3.3	N/A	N/A	N/A	TR62411, GR-1244-CORE, ETS 300 011, ITU-T G.813 (Option 1), ITU-T G.812, Stratum 4	56-SSOP

These products represent only a portion of IDT's WAN PLL portfolio. For more information about additional devices, please visit www.idt.com/timing/sonet

Synchronous Ethernet and IEEE 1588

FEATURES

- Integrated single-chip solution for Synchronous Equipment Timing Source, including Stratum Level 3, 4E, 4, SMC, EEC-Option 1 and EEC-Option 2 Clocks
- Hitless reference switching to minimize DPLL output phase transients
- Programmable input-to-output phase offset adjustment
- Provides 6 output clocks from 1 Hz (1PPS) to 644.53125 MHz
- Provides 6 input clocks from 1Hz (1PPS) to 625 MHz
- Jitter attenuation using internal analog PLL
- Provides node clock for ITU-T G.8261/G.8262 Synchronous Ethernet (SyncE)
- Provides SONET clocks with less than 1.5ps of RMS Phase Jitter (12kHz - 20MHz)

BENEFITS

- Solutions meet requirements of packet synchronization networks
- Optimized for Carrier Ethernet equipment
- Master / Slave application to enable system protection against single chip failure
- Supports Master clock calibration

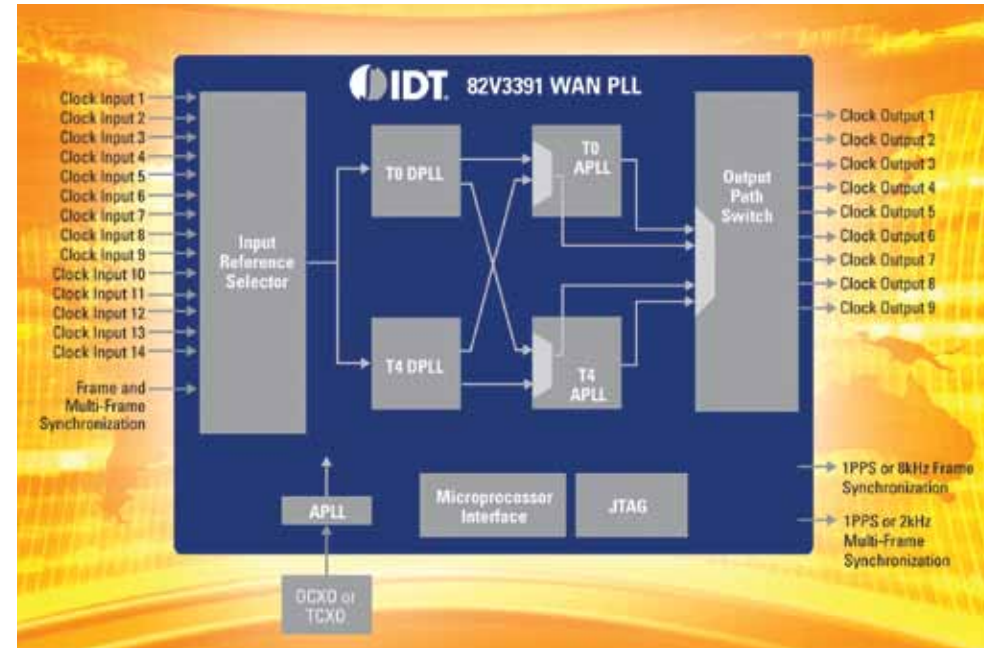

IDT's DPLLs (Digital PLLs) for IEEE1588 and synchronous Ethernet are designed for synchronization over packet switched networks. For IEEE1588 applications the embedded DCOs (Digitally Controlled Oscillators) can be used as low-jitter synthesizers for IEEE1588 clock recovery algorithms. For synchronous Ethernet applications the DPLLs comply with ITU-T recommendations for EECs (synchronous Ethernet Equipment Clocks); these devices also comply with SONET/SDH, PDH and TDM synchronization requirements. IDT's DPLLs can be switched between IEEE1588 DCO and SyncE modes; and they provide capabilities such as selectable loop filters, holdover, hitless reference switching, phase slope limiting and clock redundancy.

Part Number	# of Outputs	Output Type	Output Freq Range (MHz)	Input Frequency (MHz)	# of Inputs	Input Type	# of Output Banks	Output Voltage (V)	Output Skew (ps)	Phase Noise Typ RMS (ps)	Package Type
82V3352	4	LVPECL, LVDS, LVCMOS	0.000001 - 622.08	0.002 - 622.08	8	LVPECL, LVDS, LVCMOS	4	3.3	50	4.3	64-TQFP
82V3355	4	LVPECL, LVDS, LVCMOS	0.000001 - 622.08	0.002 - 622.08	8	LVPECL, LVDS, LVCMOS	4	3.3	50	4.3	64-TQFP
82V3358	6	LVPECL, LVDS, LVCMOS	0.000001 - 622.08	0.002 - 622.08	8	LVPECL, LVDS, LVCMOS	6	3.3	50	4.3	64-TQFP
82V3395	6	LVPECL, LVDS, LVCMOS	0.000001 - 644.53125	0.000001 - 156.25	6	LVPECL, LVDS, LVCMOS	6	3.3	150	0.2	72-OFN
82V3385	7	LVPECL, LVDS, LVCMOS	0.000001 - 622.08	0.002 - 622.08	6	LVPECL, LVDS, LVCMOS	7	3.3	50	4.3	100-TQFP
82V3389	7	LVPECL, LVDS, LVCMOS	0.000001 - 622.08	0.002 - 622.08	6	LVPECL, LVDS, LVCMOS	7	3.3	100	0.8	100-TQFP
82V3380A	11	AMI, LVPECL, LVDS, LVCMOS	0.000001 - 622.08	0.002 - 622.08	15	AMI, LVPECL, LVDS, LVCMOS	11	3.3	50	4.3	100-TQFP
82V3380	11	AMI, LVPECL, LVDS, LVCMOS	0.000001 - 622.08	0.002 - 622.08	15	AMI, LVPECL, LVDS, LVCMOS	11	3.3	50	4.3	100-TQFP
82V3390	11	AMI, LVPECL, LVDS, LVCMOS	0.002 - 625	0.002 - 625	15	AMI, LVPECL, LVDS, LVCMOS	11	3.3	100	0.3	100-TQFP
82V3391	11	AMI, LVPECL, LVDS, LVCMOS	0.002 - 625	0.002 - 625	15	AMI, LVPECL, LVDS, LVCMOS	11	3.3	150	0.2	100-TQFP

For additional information, please visit www.idt.com/timing/synce



IDT FEATURES SEVERAL FAMILIES OF
CLOCK PRODUCTS THAT ARE OPTIMIZED
FOR SPECIFIC APPLICATIONS. IN THEIR
TARGET APPLICATION, THESE PRODUCTS
PERFORM BETTER AND ARE EASIER TO USE
THAN GENERAL-PURPOSE CLOCKS.

APPLICATION SPECIFIC CLOCKS

Computing Clocks	24
PCI Express® Clocks	25
Video Clocks	26
Real Time Clocks	27



Computing Clocks

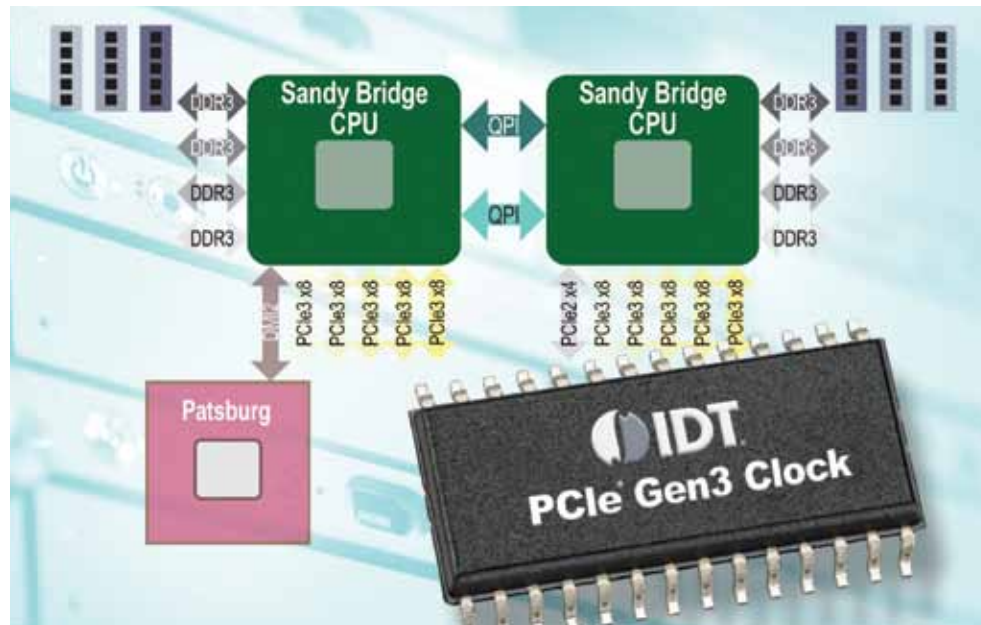

The wide range of interfaces in today's computing systems (PCI Express, SATA, USB, SAS, DMI, QPI, Hypertransport, etc.) demand a daunting array of tradeoffs in areas of performance, BOM cost, and board space. IDT has the longest standing relationship with the industry's leading CPU and Compute vendors to offer both the largest portfolio of reference clock solutions and value-added clocks that provide customer-optimized tradeoffs in the areas mentioned above. IDT is a leading innovator in the compute timing space with many firsts including: first to introduce low power HCSL outputs to replace standard-HCSL outputs for power savings up to 85%; first to provide dynamic frequency control for over/under clocking; first to incorporate multiple PLLs in a single device to save power and board space. IDT takes pride in offering timing devices with the best fit for computing platforms.

FEATURES

- Spread-Spectrum Capable
- Meet Stringent Phase Jitter requirements
- PCIe Gen1/2/3 compliant PCIe outputs
- Low-power differential outputs with and without integrated terminations
- Low Drift PCIe outputs on some parts for Non-Transparent Bridging Support
- Differential and Single-ended outputs support today's computing system requirements
- Latch or Real time Frequency select pin
- 2 to 19 output devices available
- HCSL and Low-Power HCSL compatible output types
- QPI/SMI 9.6GB/s devices available
- External feedback on some devices allows for input to output delay tuning
- Drive 85 Ω or 100 Ω differential traces
- Integrated 33 Ω series resistor on all differential outputs
- Supports Wake_On_LAN

BENEFITS

- Supports tight ppm accuracy clocks for Serial-ATA and PCIeX
- Dynamic Over Clocking capability for improved system performance
- Programmable Spread Spectrum to reduce system EMI
- Up to 5 PLLs integration to save board space
- Support SRC power management by CLKREQ# pins
- User fully programmable PLL

Part Number	Chipset	# of Outputs	Output Type	Output Freq Range (MHz)	Input Frequency (MHz)	# of Output Banks	Core Voltage (V)	Output Voltage (V)	Output Skew (ps)	App Jitter Compliance	Package Type
952601	Intel 875P,865G	23	HCSL, LVCMOS	14.318, 33.33, 48, 66.66, 100, 133.33, 166.67, 200	14.318	9	3.3	3.3	100	N/A	56-TSSOP
954101	Intel 910, 915, 925, 945, 946, 955, 975	21	HCSL, LVCMOS	14.318, 33.33, 48, 100, 133.33, 200, 233.33, 266.66, 333.33, 400	14.318	7	3.3	3.3	100	PCIe Gen 1	56-TSSOP
932S421	Intel 5400, 5520	19	HCSL, LVCMOS	14.318, 33.33, 48, 100, 133.33, 166.67, 200, 266.67, 333.33, 400	14.318	5	3.3	3.3	50	PCIe Gen 1/2, QPI	56-TSSOP
932SQ420	Intel C600	19	HCSL, LVCMOS	14.318, 33.33, 48, 96, 100, 133.33	25	7	3.3	3.3	50	PCIe Gen 1/2/3, QPI	64-TSSOP, 64-VFQFPN
9VRS4338D	Intel Atom	15	HCSL, LVCMOS	14.318, 33.33, 48, 96, 100, 133.33, 167.67, 200	14.318	10	1.5, 3.3	1.05, 1.5	205	PCIe Gen1/ 2, PCIe	48-VFQFPN
9EMS9633	Intel US15	9	HCSL, LVCMOS	14.318, 96, 100, 133.33, 166.67, 200	14.318	5	3.3	3.3	100	PCIe Gen 1	48-VFQFPN
9LPRS501	Intel P965 and newer	22	HCSL, LVCMOS	14.318, 33.33, 48, 96, 100, 133.33, 166.66, 266.66, 333.33, 400	14.318	9	3.3	1.05 - 3.3	100	PCIe Gen 1	64-TSSOP
9LPRS436	Intel NM10	14	HCSL, LVCMOS	12, 12.288, 14.318, 25, 33.33, 48, 83.33, 75, 96, 100, 133.33, 166.67	25	9	3.3	3.3	N/A	PCIe Gen 1/2	48-TSSOP, 48-VFQFPN
9LPRS525	Intel P965 and newer	19	HCSL, LVCMOS	14.318-400	14.318	9	3.3	1.05 - 3.3	100	PCIe Gen 1/2	56-TSSOP
9LRS3165	Intel P965 and newer	7	HCSL, LVCMOS	14.318, 27, 33.33, 48, 96, 100, 133.33, 200, 266.66	14.318	8	3.3	1.05 - 3.3	100	PCIe Gen 1/2	32-VFQFPN
9UMS9610	Intel US15	9	HCSL, LVCMOS	14.318, 96, 100, 133.33, 166.67, 200	14.318	5	1.5	1.5, 3.3	100	PCIe Gen 1	48-VFQFPN

These products represent only a portion of IDT's Computing Clock portfolio. For information on additional devices, please visit www.idt.com/timing/computing

FEATURES

- Non-PLL Fan-out Buffers, Clock Synthesizers, and Muxes
- Single-ended clock input to differential outputs
- Spread-spectrum options available for EMI reduction
- Zero-Delay Buffers
- 2 to 21 outputs in a single device
- Selectable PLL bandwidth allows for device cascading
- Low Power options available
- 1 to 4 outputs per device with 2 inputs
- Jitter Attenuators
- Special purpose PLL reduces incoming clock jitter

BENEFITS

- Industry's broadest offering of clock generation, buffering and muxing for PCIe Gen1, Gen2 and Gen3.
- World's first PCI Express Gen3 family of timing devices
- Low Power Product offerings

PCI Express® Clocks

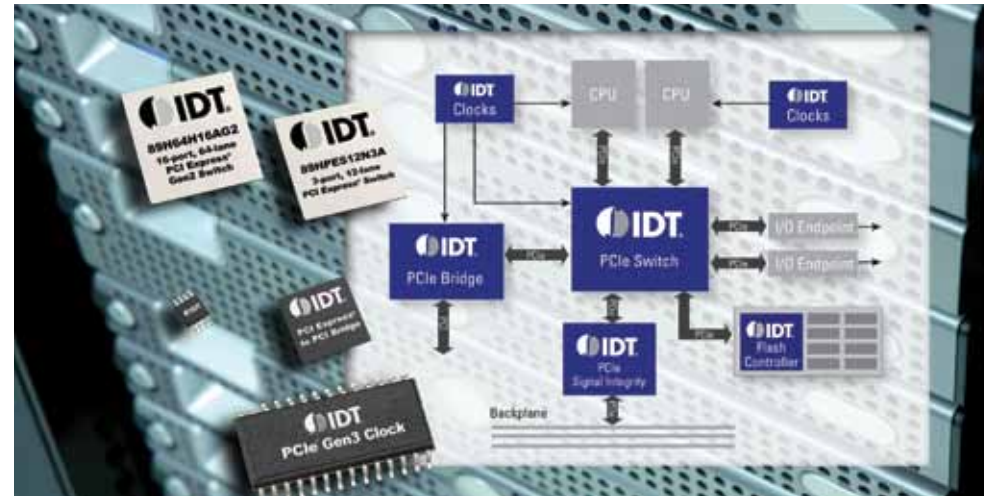

PCI Express is one of the most widely used high-performance peripheral interfaces in the world. From its origins in PC graphics, PCI Express has been adopted in fields as diverse as computing, servers, storage, networking, instrumentation and consumer. Such a wide applications space requires multiple solutions to the ever present tradeoffs of performance, BOM cost and board space. IDT's strong position with leading computing, networking and consumer customers and our participation on the appropriate standards bodies allows us to offer optimized PCI Express timing solutions for any application.

IDT has a history of firsts in PCI Express clocking: The first PCIe Gen1, Gen2 and Gen3 clocking solutions, the industry's first low power PCI Express clocking solutions; and the world's lowest power PCI Express clocking solutions. Whether your application requires PCIe Gen1, Gen2 or Gen3 performance with synthesizer, buffer or multiplexer functionality, we have the optimal solution.

Part Number	# of Outputs	Output Type	Output Freq Range (MHz)	Input Frequency (MHz)	# of Inputs	Input Type	# of Output Banks	Output Voltage (V)	Output Skew (ps)	Phase Noise Typ RMS (ps)	C-C Jitter Max P-P (ps)	App Jitter Compliance	Package Type
9DBV0231	2	LP-HCSL	50, 100, 125	50, 100, 125	1	HCSL	1	1.8	28	0.5	50	PCIe Gen 1 / 2 / 3	24-VFOFPN
9FGV0231	2	LP-HCSL	25, 100	25	1	Crystal	2	1.8	N/A	0.5	250	PCIe Gen 1 / 2 / 3	24-VFOFPN
5V41065	2	HCSL, LVDS	25-200	25	1	Crystal, LVCMOS	1	3.3	50	0.8	100	PCIe Gen 1/2	16-TSSOP
841202-245	2	HCSL	25, 100, 125, 250	25	1	Crystal	1	3.3	40	N/A	N/A	PCIe	32-VFOFPN
874003DI-02	3	LVDS	98-320	98 - 128	1	HCSL, LVDS, LVHSTL, LVPECL, SSTL	2	3.3	185	N/A	30	PCIe	20-TSSOP
557-05A	4	HCSL, LVDS	100, 200	25	1	Crystal, LVCMOS	1	3.3	50	N/A	80	PCIe	20-TSSOP
5V41066	4	HCSL, LVDS	25-200	25	1	Crystal, LVCMOS	1	3.3	50	0.76	100	PCIe Gen 1/2	20-TSSOP
9FG104E	5	HCSL	100, 125, 133.33, 166.67, 200, 266, 333, 400	14, 318, 25	1	Crystal, LVCMOS	2	3.3	30	0.25	50	PCIe Gen 1/2, OPI	28-TSSOP
9DBV0831	8	LP-HCSL	50, 100, 125	50, 100, 125	1	HCSL	1	1.8	28	0.5	50	PCIe Gen 1 / 2 / 3	48-VFOFPN
9FGV0831	8	LP-HCSL	25, 100	25	1	Crystal	2	1.8	N/A	0.5	250	PCIe Gen 1 / 2 / 3	48-VFOFPN
9FG108E	9	HCSL, LVCMOS	100, 125, 133.33, 166.67, 200, 266, 333, 400	14, 318, 25	1	Crystal, LVCMOS	2	3.3	50	N/A	50	PCIe Gen 1/2, OPI	48-SSOP, 48-TSSOP
9ZXL1230	12	HCSL	0-400	33 - 147	1	LVCMOS	1	3.3	65	0.12	50	PCIe Gen 3, OPI	56-VFOFPN
9EX21831	18	LVCMOS	0-166	33 - 167	2	LVCMOS	1	3.3	150	0.5	50	PCIe Gen 1 / 2 / 3	72-MLF
9ZX21901C	19	HCSL	0-400	33 - 140	1	HCSL	1	3.3	65	0.18	50	PCIe Gen 2 / 3	72-MLF

These products represent only a portion of IDT's PCIe Clock portfolio. For information on additional devices, please visit www.idt.com/timing/pcie

Video Clocks

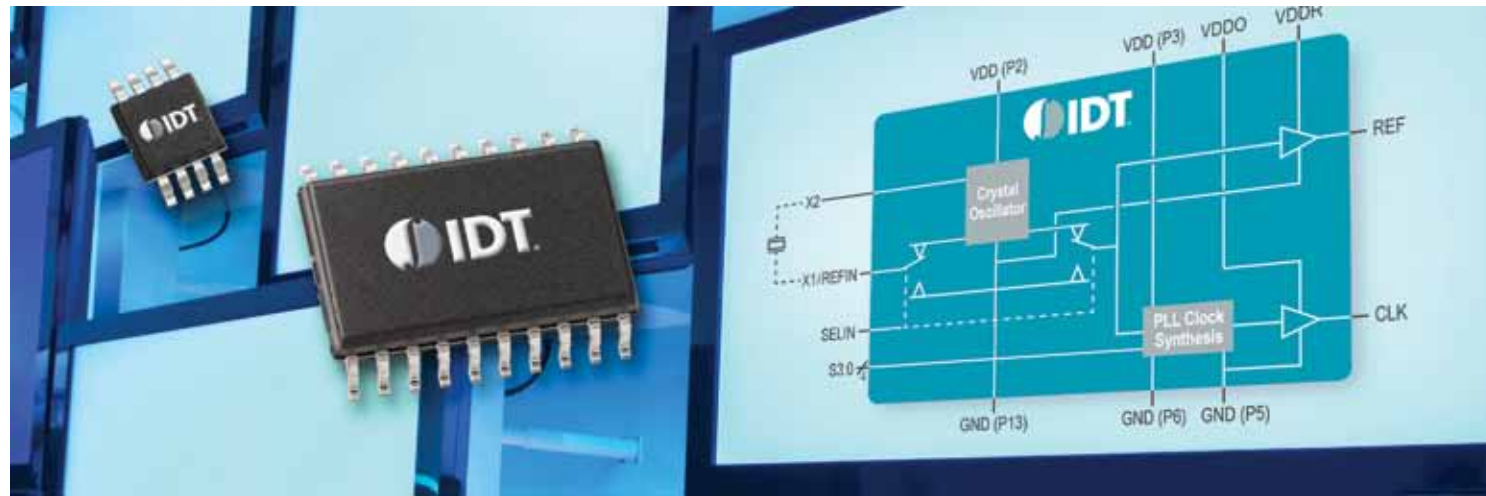

IDT video clocks are designed specifically for video applications which include GENLOCK clock synthesizers and general purpose audio/video clocks. They use a simple, low cost, fundamental-mode-quartz crystal as the frequency reference to synthesize low jitter video clock outputs. IDT offers clock outputs in both differential and single-ended formats. In certain IDT video clocks, Dynamic Phase Adjust allows I2C control of the output clocks phase relative to the input sync signal. A second, half-speed set of outputs that can be separately enabled allows such applications as clocking analog to digital converters.

Applications for IDT's video clocks include televisions, projectors, LCD monitors, and embedded displays.

FEATURES

- Single and multiple frequencies
- I²C Programming
- GENLOCK clock support
- Support for HDTV, NTSC and PAL clock sources
- User programmable

BENEFITS

- Consolidation of multiple clock frequencies into a single device
- Low cost
- Reduction in BOM components required

Part Number	Function	Input Frequency (MHz)	Output Voltage (V)	# of Outputs	Prog. Clock	Period Jitter Typ (ps)	Package Type
662M-03	HDTV Audio/Video Clock Source	74.25, 74.175824	3.3	1	No	75	8-SOIC
664G-01	Digital Video Clock Source	13.5, 27, 74.25, 74.175824, 54	3.3, 2.5	1	No	100	16-TSSOP
810001-22	FemtoClock Dual VCXO Video PLL	0.0156094 - 0.0675	3.3	1	Yes	N/A	32-VFOFPN
MK2712	NTSC / PAL Clock Source	27	3.3, 5	1	No	180	8-SOIC
660	Digital Video Clock Source	13.5, 27, 74.25, 74.175824, 16.9344, 125, 14.3181818, 106.25, 27.027	2.5, 3.3	2	No	125	16-TSSOP
664G-02	PECL Digital Video Clock Source	13.5, 27, 74.25, 74.175824, 54	3.3, 2.6	2	No	70	16-TSSOP
MK2703	PLL Audio Clock Synthesizer	27	3.3, 5	2	No	190	8-SOIC
MK2716	HDTV Clock Synthesizer	27	3.3, 5	2	No	200	8-SOIC
664G-03	Digital Video Clock Source	13.5, 27, 74.25, 74.175824, 54	3.3, 2.7	3	No	100	16-TSSOP
664G-05	Digital Video Clock Source	27, 74.25, 74.175824, 54, 67.5	3.3, 2.8	4	No	100	16-TSSOP
1523	Video Clock Synthesizer with I ² C Programmable Delay	0.05-100	3.3	5	Yes	N/A	24-SOIC
MK2745-21	DVD / MPEG Clock Source	27	3.3, 5	5	No	200	16-SOIC
MK2761A	Set-Top Clock Source	27	5	7	No	250	16-SOIC
MK2745-24	DVD / MPEG Clock Source	20 - 160	3.3, 5	8	No	300	16-SOIC
MK3771-17	VCXO and HDTV Set-Top Clock Source	13.5	3.3	8	No	250	28-OSOP

These products represent only a portion of IDT's Video Clock portfolio. For information on additional devices, please visit www.idt.com/timing/video

Real Time Clocks

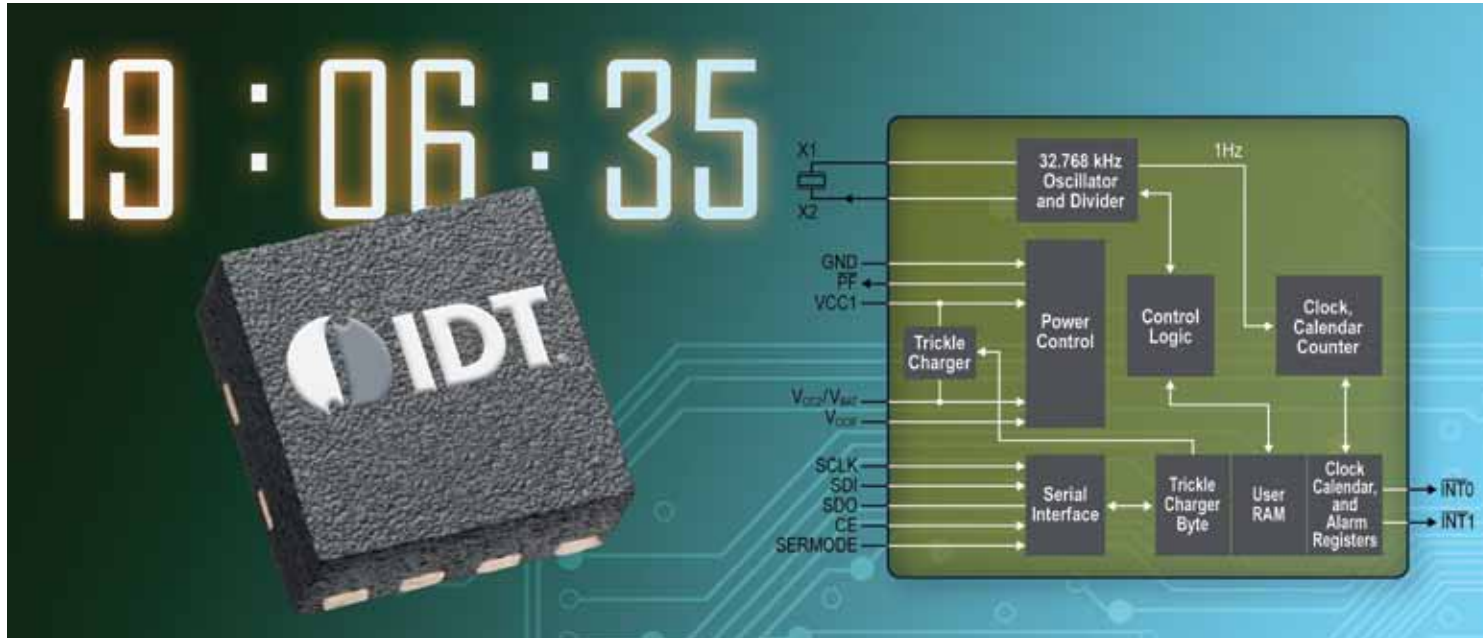

FEATURES

- Real-Time Clock (RTC) counts seconds, minutes, hours, day, date, month, and year with leap-year compensation valid up to 2100
- Operating voltage of 1.8 to 5.5 V
- Fast mode I²C Serial interface
- Programmable square-wave output
- Packaged in 8-pin MSOP, 8-pin SOIC, or 16-pin SOIC (with an integrated crystal)

BENEFITS

- Ultra low-power time keeping device
- Alternate source of power so can keep time while the primary source of power is off or unavailable
- Alarms allow system to execute tasks at a certain time

A **Real-time Clock (RTC)** with a 32.768kHz quartz tuning-fork crystal is the standard timekeeping reference for most electronic applications. The RTC maintains the time and date by counting seconds, which requires a 1Hz clock signal derived from the 32.768kHz crystal oscillator. The current time and date information is stored in a set of registers which is accessed through a communication interface, typically I²C. RTCs often have an alternate source of power so they can keep time while the primary source of power is off or unavailable. The IDT RTCs that have this Vbat pin automatically detect the loss of the primary source of power and switch over to running the device from the battery. The dual power-supplies support a programmable trickle charge circuit that allows a rechargeable energy source such as a super capacitor or rechargeable battery. IDT RTCs have programmable time-of-day alarms that can generate an interrupt on a programmable combination of seconds, minutes, hours and day. IDT RTCs also have additional battery-backed non-volatile RAM (NVRAM) to store critical data.

Generic	Operating Voltage (V)	Time of Day Alarms	Extra Battery Backed nVRAM (Bytes)	Trickle Charge	VBAT	Option w/Crystal Inside	Package Type
1337G	1.8 - 5.5	2	0	N	N	Y	8-MSOP, 8-SOIC, 16-SOIC, 16-OFN
1338-18	1.8 - 5.5	0	56	N	Y	Y	8-SOIC, 8-TSSOP
1338-31	2.7 - 5.5	0	56	N	Y	Y	8-SOIC, 8-TSSOP
1339-2	1.8 - 5.5	2	0	Y	Y	Y	8-SOIC, 8-TSSOP
1339-31	2.7 - 5.5	2	0	Y	Y	Y	8-SOIC, 8-TSSOP

For additional information, please visit www.idt.com/timing/rtc



FOX ELECTRONICS, AN IDT COMPANY, IS A LEADING GLOBAL SUPPLIER OF FREQUENCY CONTROL PRODUCTS. FOX'S PRODUCT PORTFOLIO AND LEADERSHIP IN THE FREQUENCY CONTROL MARKET, COUPLED WITH IDT'S FREQUENCY CONTROL PRODUCTS, OFFER THE INDUSTRY'S MOST COMPREHENSIVE ONE-STOP SHOP FOR FREQUENCY CONTROL PRODUCTS.

CRYSTALS, OSCILLATORS AND CRYSTALFREE™ FREQUENCY CONTROL PRODUCTS



Fox Electronics Crystals	30
Fox Electronics Xpresso® Oscillators	32
Fox Electronics Oscillators	34
Fox Electronics TCXO and OCXOs	36
Quartz-Crystal and SAW Oscillators	37
CrystalFree™ Piezo MEMS (pMEMS™) Oscillators and Crystal Replacements	38



Fox Electronics Crystals



FOX ELECTRONICS' mission has been to provide a broad line of highly precise, highly reliable frequency control products to the worldwide electronics markets. Combining the disciplines of advanced engineering, flexible manufacturing, quality assurance, operations, information systems and marketing, Fox strives to provide our customers with superior quality, excellent service, leading edge products, and thoroughly knowledgeable application support. Our ability to meet those objectives is reflected in our long-term and on-going ranking as America's preferred source for frequency control products.

Fox produces six basic classes of products: quartz crystals in more than 20 types including micro and ultra miniature, thru-hole or surface mount, with stabilities as low as 3 PPM, and frequencies to over 200 MHz; clock oscillators, including standard quartz oscillators, low current oscillators, tight stability oscillators, and configurable oscillators in HCMOS and complementary output types in frequencies up to 1.35 GHz; temperature compensated, voltage controlled, and oven controlled crystal oscillators (TCXOs, VCXOs, and OCXOs); and monolithic crystal filters.

FEATURES

- Extremely broad product range
- Industry standard packages
- Leading edge technologies

BENEFITS

- Cost-effective development with rapid turnaround
- Engineered solutions from minor modifications to full custom
- Dedicated engineering support team
- Advanced frequency control expertise

FOX ELECTRONICS CRYSTALS

Part Number	Frequency Range	Frequency Tolerance	Frequency Stability	Temperature Range	Package	Notes
FX216 Series	24 MHz ~ 60 MHz	± 50 PPM ~ ± 10 PPM	± 50 PPM ~ ± 10 PPM	-10°C ~ +60°C to -40°C ~ +85°C	2 x 1.6 x 0.4 mm	4-pad design RoHS compliant
FX252BS	12 MHz ~ 80 MHz	±50 PPM ~ ± 10 PPM	± 50 PPM ~ ± 10 PPM	0°C ~ +70°C to -40°C ~ +85°C	2.5 x 2 x 0.6 mm	4-pad design RoHS compliant
FQ3225B	12 MHz ~ 50 MHz	± 30 PPM~ ± 20 PPM	± 30 PPM~ ± 20 PPM	-10°C ~ +70°C to -40°C ~ +85°C	3.2 x 2.5 x 1.0 mm	4-pad design RoHS compliant
FX325BS	16 MHz ~ 50 MHz	± 50 PPM ~ ± 10 PPM	± 50 PPM ~ ± 10 PPM	-10°C ~ +60°C to -40°C ~ +85°C	3.2 x 2.5 x 0.8 mm	4-pad design RoHS compliant
FQ5032 Series	12 MHz ~ 48 MHz	± 30 PPM~ ± 20 PPM	± 30 PPM~ ± 20 PPM	0°C ~ +70°C to -40°C ~ +85°C	5 x 3.2 x 1.2 mm	2- or 4-pad design RoHS compliant
FX532 Series	10 MHz ~ 67 MHz	± 50 PPM ~ ± 10 PPM	± 50 PPM ~ ± 10 PPM	-10°C ~ +60°C to -40°C ~ +85°C	5 x 3.2 x 1.0 mm	2- or 4-pad design RoHS compliant
FQ6035 Series	6 MHz ~ 40 MHz	± 30 PPM~ ± 20 PPM	± 30 PPM~ ± 20 PPM	0°C ~ +70°C to -40°C ~ +85°C	6 x 3.5 x 1.3 mm	2- or 4-pad design RoHS compliant
FMB	9 MHz ~ 176 MHz	± 50 PPM~ ± 5 PPM	± 50 PPM~ ± 3 PPM	-10°C ~ +60°C to -40°C ~ +85°C	6 x 3.5 x 1.1 mm	4-pad design RoHS compliant
FD	6 MHz ~ 218 MHz	± 50 PPM~ ± 5 PPM	± 50 PPM~ ± 3 PPM	-10°C ~ +60°C to -40°C ~ +85°C	7 x 5 x 1.1 mm	4-pad design RoHS compliant
FE	6 MHz ~ 160 MHz	± 50 PPM~ ± 20 PPM	± 50 PPM~ ± 20 PPM	-10°C ~ +60°C to -40°C ~ +85°C	7 x 5 x 1.7 mm	2-pad design RoHS compliant
FQ1045A	3.2768 MHz ~ 7 MHz	± 30 PPM~ ± 20 PPM	± 30 PPM~ ± 20 PPM	0°C ~ +70°C to -40°C ~ +85°C	10 x 4.5 x 1.7 mm	4-pad design RoHS compliant
HC49SDF	3.2 MHz ~ 80 MHz	± 50 PPM~ ± 10 PPM	± 50 PPM~ ± 5 PPM	-20°C ~ +70°C to -40°C ~ +85°C	13.9 x 5 x 4.5 mm	Industry standard RoHS compliant

AUTOMOTIVE GRADE AEC-Q200 CRYSTALS

Part Number	Frequency Range	Frequency Tolerance	Frequency Stability	Temperature Range	Package	Notes
FXA2520	16 MHz ~ 50 MHz	± 50 PPM	± 50 PPM ~ ± 100 PPM	-40°C ~ +85°C to -40°C ~ +125°C	2.5 x 2 x 0.6mm	4-pad design RoHS compliant
FXA3225	12 MHz ~ 52 MHz	± 50 PPM	± 50 PPM ~ ± 100 PPM	-40°C ~ +85°C to -40°C ~ +125°C	3.2 x 2.5 x 0.75 mm	4-pad design RoHS compliant
FXA5032	8 MHz ~ 52 MHz	± 50 PPM	± 50 PPM ~ ± 100 PPM	-40°C ~ +85°C to -40°C ~ +125°C	5 x 3.2 x 1.0 mm	4-pad design RoHS compliant
FXA7050	6 MHz ~ 48 MHz	± 50 PPM	± 50 PPM ~ ± 100 PPM	-40°C ~ +85°C to -40°C ~ +125°C	7 x 5 x 1.1 mm	4-pad design RoHS compliant

WATCH CRYSTALS

Part Number	Frequency Range	Frequency Tolerance	Frequency Stability	Temperature Range	Package	Notes
FX122	32.768 kHz	± 20 PPM	-0.04 PPM / ΔC ²	-40°C ~ +85°C	2.0 x 1.2 x 0.6 mm	12.5pF or 9pF RoHS Compliant
FX135	32.768 kHz	± 20 PPM	-0.04 PPM / ΔC ²	-40°C ~ +85°C	3.2 x 1.5 x 0.9 mm	12.5pF or 9pF RoHS Compliant
FX145	32.768 kHz	± 20 PPM	-0.04 PPM / ΔC ²	-40°C ~ +85°C	4.1 x 1.5 x 0.9 mm	12.5pF RoHS Compliant
FX255	32.768 kHz	± 20 PPM	-0.04 PPM / ΔC ²	-40°C ~ +85°C	4.9 x 1.8 x 1.0 mm	12.5pF RoHS Compliant
FSXLF	32.768 kHz	± 20 PPM	-0.04 PPM / ΔC ²	-40°C ~ +85°C	7 x 1.5 x 1.4 mm	12.5pF or 7pF RoHS Compliant
FSRLF	32.768 kHz	± 20 PPM	-0.04 PPM / ΔC ²	-40°C ~ +85°C	8.7 x 3.7 x 2.5 mm	12.5pF or 6pF RoHS Compliant
FSMLF	32.768 kHz	± 20 PPM	-0.04 PPM / ΔC ²	-40°C ~ +85°C	10.41 x 4.06 x 3.56 mm	12.5pF or 6pF RoHS Compliant
NCLF Series	32.768 kHz	± 20 PPM	-0.04 PPM / ΔC ²	-40°C ~ +85°C	3 x 8, 2 x 6, or 1 x 5 mm	12.5pF or 6pF RoHS Compliant

These products represent only a portion of Fox's Crystal portfolio. For the most complete and current engineering data available, please visit www.foxonline.com

Fox Electronics XpressO[®] Crystal Oscillators



WHO SAYS YOU CAN'T HAVE IT ALL? — The revolutionary XpressO[®] crystal oscillator family from Fox provides a wider range of options, with fewer compensating factors, shorter lead times, and reduced pricing. Instead of being faced with crucial tradeoffs in cost, performance, or delivery times, you can have virtually the best of all worlds in one package.

Great for your designs: If an oscillator can't deliver the performance you need in your design, it doesn't matter how much it costs. But Fox XpressO oscillators with patented technologies (including proprietary ASICs with noise reduction silicon architectures and proven production techniques) deliver accurate performance over an extremely wide range of parameters – all at a lower cost than conventional oscillators!

Great for your business, too! – Specifying the optimum oscillator for your design is only half the battle. Getting it delivered in time to meet the most pressing customer deadlines for engineering prototypes or full production models – without technical compromise and without paying a premium – can be the difference between a profitable contract and a lost opportunity. This is where XpressO really lives up to its name.

FEATURES

- The exact frequency you need, from 0.750 MHz to 1.350 GHz
- Stabilities as tight as ± 20 ppm
- Low jitter and phase noise characteristics
- Choice of HCMOS, LVDS, and LVPECL versions for both XO and VCXO product families
- Choice of 2.5 V or 3.3 V supply voltages
- Choice of 7 x 5 mm, 5 x 3.2 mm and 3.2 x 2.5 mm package sizes

BENEFITS

- Next day shipment of samples for prototyping
- Mere days for lead times on production quantities
- A new pricing structure that won't penalize you for requesting quick turnaround on unique frequencies

Part Number	Frequency Range	Frequency Stability	Temperature Range	Package	Voltage operation	Phase Jitter	Output
FXO-HC32 Series	750 kHz ~ 180 MHz	$\pm 100, \pm 50, \pm 25$ PPM	-20°C ~ +70°C -40°C ~ +85°C (Option)	3.2 x 2.5 mm	2.5 V	< 1pS Phase Jitter	HCMOS
FXO-HC33 Series	750 kHz ~ 250 MHz	$\pm 100, \pm 50, \pm 25$ PPM	-20°C ~ +70°C -40°C ~ +85°C (Option)	3.2 x 2.5 mm	3.3 V	< 1pS Phase Jitter	HCMOS
FXO-LC32 Series	750 kHz ~ 1 GHz	$\pm 100, \pm 50, \pm 25$ PPM	-20°C ~ +70°C -40°C ~ +85°C (Option)	3.2 x 2.5 mm	2.5 V	< 1pS Phase Jitter	LVDS
FXO-LC33 Series	750 kHz ~ 1.35 GHz	$\pm 100, \pm 50, \pm 25$ PPM	-20°C ~ +70°C -40°C ~ +85°C (Option)	3.2 x 2.5 mm	3.3 V	< 1pS Phase Jitter	LVDS
FXO-HC52 Series	750 kHz ~ 180 MHz	$\pm 100, \pm 50, \pm 25, \pm 20$ PPM	-20°C ~ +70°C -40°C ~ +85°C (Option)	5 x 3.2 mm	2.5 V	< 1pS Phase Jitter	HCMOS
FXO-HC53 Series	750 kHz ~ 250 MHz	$\pm 100, \pm 50, \pm 25, \pm 20$ PPM	-20°C ~ +70°C -40°C ~ +85°C (Option)	5 x 3.2 mm	3.3 V	< 1pS Phase Jitter	HCMOS
FXO-PC52 Series	750 kHz ~ 1 GHz	$\pm 100, \pm 50, \pm 25, \pm 20$ PPM	-20°C ~ +70°C -40°C ~ +85°C (Option)	5 x 3.2 mm	2.5 V	< 1pS Phase Jitter	LV-PECL
FXO-PC53 Series	750 kHz ~ 1.35 GHz	$\pm 100, \pm 50, \pm 25, \pm 20$ PPM	-20°C ~ +70°C -40°C ~ +85°C (Option)	5 x 3.2 mm	3.3 V	< 1pS Phase Jitter	LV-PECL
FXO-LC52 Series	750 kHz ~ 1 GHz	$\pm 100, \pm 50, \pm 25, \pm 20$ PPM	-20°C ~ +70°C -40°C ~ +85°C (Option)	5 x 3.2 mm	2.5 V	< 1pS Phase Jitter	LVDS
FXO-LC53 Series	750 kHz ~ 1.35 GHz	$\pm 100, \pm 50, \pm 25, \pm 20$ PPM	-20°C ~ +70°C -40°C ~ +85°C (Option)	5 x 3.2 mm	3.3 V	< 1pS Phase Jitter	LVDS
FXO-HC72 Series	750 kHz ~ 180 MHz	$\pm 100, \pm 50, \pm 25, \pm 20$ PPM	-20°C ~ +70°C -40°C ~ +85°C (Option)	7 x 5 mm	2.5 V	< 1pS Phase Jitter	HCMOS

IDT TIMING SOLUTIONS

Part Number	Frequency Range	Frequency Stability	Temperature Range	Package	Voltage operation	Phase Jitter	Output
FXO-HC73 Series	750 kHz ~ 250 MHz	±100, ±50, ±25, ±20 PPM	-20°C ~ +70°C -40°C ~ +85°C (Option)	7 x 5 mm	3.3 V	< 1pS Phase Jitter	HCMOS
FXO-PC72 Series	750 kHz ~ 1 GHz	±100, ±50, ±25, ±20 PPM	-10°C ~ +70°C -40°C ~ +85°C (Option)	7 x 5 mm	2.5 V	< 1pS Phase Jitter	LV-PECL
FXO-PC73 Series	750 kHz ~ 1.35 GHz	±100, ±50, ±25, ±20 PPM	-10°C ~ +70°C -40°C ~ +85°C (Option)	7 x 5 mm	3.3 V	< 1pS Phase Jitter	LV-PECL
FXO-LC72 Series	750 kHz ~ 1 GHz	±100, ±50, ±25, ±20 PPM	-20°C ~ +70°C -40°C ~ +85°C (Option)	7 x 5 mm	2.5 V	< 1pS Phase Jitter	LVDS
FXO-LC73 Series	750 kHz ~ 1.35 GHz	±100, ±50, ±25, ±20 PPM	-20°C ~ +70°C -40°C ~ +85°C (Option)	7 x 5 mm	3.3 V	< 1pS Phase Jitter	LVDS

Xpress0® VCX0's

Part Number	Frequency Range	Frequency Pullability	Temperature Range	Package	Voltage Operation	Phase Jitter	Output
FVXO-HC52 Series	750 kHz ~ 180 MHz	± 50 PPM APR	-20°C ~ +70°C -40°C ~ +85°C (Option)	5 x 3.2 mm	2.5 V	< 1pS Phase Jitter	HCMOS
FVXO-HC53 Series	750 kHz ~ 250 MHz	± 50 PPM APR	-20°C ~ +70°C -40°C ~ +85°C (Option)	5 x 3.2 mm	3.3 V	< 1pS Phase Jitter	HCMOS
FVXO-LC52 Series	750 kHz ~ 1 GHz	± 50 PPM APR	-20°C ~ +70°C -40°C ~ +85°C (Option)	5 x 3.2 mm	2.5 V	< 1pS Phase Jitter	LVDS
FVXO-LC53 Series	750 kHz ~ 1.35 GHz	± 50 PPM APR	-20°C ~ +70°C -40°C ~ +85°C (Option)	5 x 3.2 mm	3.3 V	< 1pS Phase Jitter	LVDS
FVXO-PC52 Series	750 kHz ~ 1 GHz	± 50 PPM APR	-20°C ~ +70°C -40°C ~ +85°C (Option)	5 x 3.2 mm	2.5 V	< 1pS Phase Jitter	LVPECL
FVXO-PC53 Series	750 kHz ~ 1.35 GHz	± 50 PPM APR	-20°C ~ +70°C -40°C ~ +85°C (Option)	5 x 3.2 mm	3.3 V	< 1pS Phase Jitter	LVPECL
FVXO-HC72 Series	750 kHz ~ 180 MHz	± 50 PPM APR	-20°C ~ +70°C -40°C ~ +85°C (Option)	7.5 x 5 mm	2.5 V	< 1pS Phase Jitter	HCMO
FVXO-HC73 Series	750 kHz ~ 250 MHz	± 50 PPM APR	-20°C ~ +70°C -40°C ~ +85°C (Option)	7.5 x 5 mm	3.3 V	< 1pS Phase Jitter	HCMO
FVXO-LC72 Series	750 kHz ~ 1 GHz	± 50 PPM APR	-20°C ~ +70°C -40°C ~ +85°C (Option)	7.5 x 5 mm	2.5 V	< 1pS Phase Jitter	LVDS
FVXO-LC73 Series	750 kHz ~ 1.35 GHz	± 50 PPM APR	-20°C ~ +70°C -40°C ~ +85°C (Option)	7.5 x 5 mm	3.3 V	< 1pS Phase Jitter	LVDS
FVXO-PC72 Series	750 kHz ~ 1 GHz	± 50 PPM APR	-20°C ~ +70°C -40°C ~ +85°C (Option)	7.5 x 5 mm	2.5 V	< 1pS Phase Jitter	LVPECL
FVXO-PC73 Series	750 kHz ~ 1.35 GHz	± 50 PPM APR	-20°C ~ +70°C -40°C ~ +85°C (Option)	7.5 x 5 mm	3.3 V	< 1pS Phase Jitter	LVPECL

Xpress0® TCX0s

Part Number	Frequency Range	Frequency Stability	Temperature Range	Package	Voltage Operation	Output
FXTC-HE72 Series	750 kHz ~ 180 MHz	± 5, ± 2.5, ± 1.5, ± 1 PPM	0°C ~ +70°C; -40°C ~ +85°C (Option)	7 x 5 mm	2.5 V	HCMOS
FXTC-HE73 Series	750 kHz ~ 250 MHz	± 5, ± 2.5, ± 1.5, ± 1 PPM	0°C ~ +70°C; -40°C ~ +85°C (Option)	7 x 5 mm	3.3 V	HCMOS
FXTC-LE72 Series	750 kHz ~ 1 GHz	± 5, ± 2.5, ± 1.5, ± 1 PPM	0°C ~ +70°C; -40°C ~ +85°C (Option)	7 x 5 mm	2.5 V	LVDS
FXTC-LE73 Series	750 kHz ~ 1.35 GHz	± 5, ± 2.5, ± 1.5, ± 1 PPM	0°C ~ +70°C; -40°C ~ +85°C (Option)	7 x 5 mm	3.3 V	LVDS

These products represent only a portion of Fox's Xpress0® portfolio. For the most complete and current engineering data available, please visit www.foxonline.com

Fox Electronics Oscillators



Part Number	Frequency Range	Frequency Stability	Temperature Range	Package	Voltage Operation	Output
F110 Series	1 MHz ~ 80 MHz	±100, ±50, ±25 PPM	-10°C ~ +70°C -40°C ~ +85°C (Option)	2.0 x 1.6 mm	1.8 V	HCMOS
F140 Series	1 MHz ~ 80 MHz	±100, ±50, ±25 PPM	-10°C ~ +70°C -40°C ~ +85°C (Option)	2.0 x 1.6 mm	2.5 V	HCMOS
F130 Series	1 MHz ~ 80 MHz	±100, ±50, ±25 PPM	-10°C ~ +70°C -40°C ~ +85°C (Option)	2.0 x 1.6 mm	3.3 V	HCMOS
F200 Series	1.8 MHz ~ 50MHz	±100, ±50, ±25 PPM	-10°C ~ +70°C -40°C ~ +85°C (Option)	2.5 x 2.0 mm	1.0 V	HCMOS
F210 Series	750 kHz ~ 50 MHz	±100, ±50, ±25 PPM	-10°C ~ +70°C -40°C ~ +85°C (Option)	2.5 x 2.0 mm	1.8 V	HCMOS
F240 Series	750 kHz ~ 50 MHz	±100, ±50, ±25 PPM	-10°C ~ +70°C -40°C ~ +85°C (Option)	2.5 x 2.0 mm	2.5 V	HCMOS
F230 Series	750 kHz ~ 67 MHz	±100, ±50, ±25 PPM	-10°C ~ +70°C -40°C ~ +85°C (Option)	2.5 x 2.0 mm	3.3 V	HCMOS
F247/F249	4 MHz ~ 54 MHz	±20, ±15, ±10 PPM	-10°C ~ +70°C -40°C ~ +85°C (Option)	2.5 x 2.0 mm	2.5 V	HCMOS
F237/F239	4 MHz ~ 54 MHz	±20, ±15, ±10 PPM	-10°C ~ +70°C -40°C ~ +85°C (Option)	2.5 x 2.0 mm	3.3 V	HCMOS
F300 Series	1.8 MHz ~ 50 MHz	±100, ±50, ±25, ±20 PPM	-10°C ~ +70°C -40°C ~ +85°C (Option)	3.2 x 2.5 mm	1.0 V	HCMOS
F310 Series	1.8 MHz ~ 80 MHz	±100, ±50, ±25, ±20 PPM	-10°C ~ +70°C -40°C ~ +85°C (Option)	3.2 x 2.5 mm	1.8 V	HCMOS
F340 Series	625 kHz ~ 80 MHz	±100, ±50, ±25, ±20 PPM	-10°C ~ +70°C -40°C ~ +85°C (Option)	3.2 x 2.5 mm	2.5 V	HCMOS
F330 Series	625 kHz ~ 75 MHz	±100, ±50, ±25, ±20 PPM	-10°C ~ +70°C -40°C ~ +85°C (Option)	3.2 x 2.5 mm	3.3 V	HCMOS
F347/F349	4 MHz ~ 54 MHz	±15, ±10 PPM	-10°C ~ +70°C -40°C ~ +85°C (Option)	3.2 x 2.5 mm	2.5 V	HCMOS
F337/F339	4 MHz ~ 54 MHz	±15, ±10 PPM	-10°C ~ +70°C -40°C ~ +85°C (Option)	5 x 3.2 mm	3.3 V	HCMOS

Part Number	Frequency Range	Frequency Stability	Temperature Range	Package	Voltage Operation	Output
F510	1.544 MHz ~125 MHz	±100, ±50, ±25, ±20 PPM	-10°C to +70°C -40°C to +85°C (Option)	5 x 3.2 mm	1.8 V	HCMOS
F540	1.8 MHz ~ 125 MHz	±100, ±50, ±25, ±20 PPM	-10°C to +70°C -40°C to +85°C (Option)	5 x 3.2 mm	2.5 V	HCMOS
F530	1.544 MHz ~155.52 MHz	±100, ±50, ±25, ±20 PPM	-10°C to +70°C -40°C to +85°C (Option)	5 x 3.2 mm	3.3 V	HCMOS
F547 / F549	4 MHz ~ 54 MHz	±15, ±10, ±8 PPM	-10°C to +70°C -40°C to +85°C (Option)	5 x 3.2 mm	2.5 V	HCMOS
F537 / F539	4 MHz ~ 54 MHz	±15, ±10, ±8 PPM	-10°C to +70°C -40°C to +85°C (Option)	5 x 3.2 mm	2.5 V	HCMOS
F4500 Series	1.8 MHz ~ 160 MHz	±100, ±50, ±25, ±20 PPM	-10°C ~ +70°C -40°C ~ +85°C (Option)	7 x 5 mm	1.8 V	HCMOS
F4400 Series	1.8 MHz ~ 125 MHz	±100, ±50, ±25, ±20 PPM	-10°C ~ +70°C -40°C ~ +85°C (Option)	7 x 5 mm	2.5 V	HCMOS
F4100 Series	12 kHz ~ 170 MHz	±100, ±50, ±25, ±20 PPM	-10°C ~ +70°C -40°C ~ +85°C (Option)	7 x 5 mm	3.3 V	HCMOS
F4107/F4109 Series	1.8 MHz ~ 54 MHz	±20, ±15, ±10, ±8 PPM	-10°C ~ +70°C -40°C ~ +85°C (Option)	7 x 5 mm	3.3 V	HCMOS
F4101 Series	12 kHz ~ 170 MHz	±100, ±50, ±25, ±20 PPM	-10°C ~ +70°C -40°C ~ +85°C (Option)	7 x 5 mm	5.0 V	HCMOS
F3345 Series	1 MHz ~ 80 MHz	±100, ±50, ±25, ±20 PPM	-10°C ~ +70°C -40°C ~ +85°C (Option)	7 x 5 mm	5.0 V	HCMOS

AUTO GRADE AEC-Q200 OSCILLATORS

Part Number	Frequency Range	Frequency Stability	Temperature Range	Package	Voltage Operation	Output
FA510	2 MHz ~ 48 MHz	±100, ±50, ±25 PPM	-40°C ~ +85°C -40°C ~ +125°C (Option)	5 x 3.2 mm	1.8 V	HCMOS
FA540	2 MHz ~ 75 MHz	±100, ±50, ±25 PPM	-40°C ~ +85°C -40°C ~ +125°C (Option)	5 x 3.2 mm	2.5 V	HCMOS
FA530	2 MHz ~ 135 MHz	±100, ±50, ±25 PPM	-40°C ~ +85°C -40°C ~ +125°C (Option)	5 x 3.2 mm	3.3 V	HCMOS
FA4500	2 MHz ~ 48 MHz	±100, ±50, ±25 PPM	-40°C ~ +85°C -40°C ~ +125°C (Option)	7 x 5 mm	1.8 V	HCMOS
FA4400	2 MHz ~ 75 MHz	±100, ±50, ±25 PPM	-40°C ~ +85°C -40°C ~ +125°C (Option)	7 x 5 mm	2.5 V	HCMOS
FA4100	2 MHz ~ 135 MHz	±100, ±50, ±25 PPM	-40°C ~ +85°C -40°C ~ +125°C (Option)	7 x 5 mm	3.3 V	HCMOS

These products represent only a portion of Fox's Oscillator portfolio. For the most complete and current engineering data available, please visit www.foxonline.com



Fox Electronics TCXOs and OCXOs



TCXOs						
Part Number	Frequency Range	Frequency Stability	Temperature Range	Package	Voltage Operation	Output
FOX922 Series	10 MHz ~ 40 MHz	± 2 PPM	-20°C ~ +75°C	2.5 x 2 mm	2.5 ~ 3.3 V	Clipped Sine
FOX922-GP Series	16 MHz ~ 38.4 MHz	± 0.5 PPM	-30°C ~ +85°C	2.5 x 2 mm	1.8 ~ 3.3 V	Clipped Sine
FOX251 Series	4 MHz ~ 54 MHz	± 2.5 PPM	-30°C ~ +85°C	2.5 x 2 mm	2.5 ~ 3.3 V	HCMOS
FOX923 Series	8 MHz ~ 52 MHz	± 2.5 PPM	-30°C ~ +85°C	3.2 x 2.5 mm	1.8 ~ 3.3 V	Clipped Sine
FOX923-GP Series	10 MHz ~ 27.456 MHz	± 0.5 PPM	-30°C ~ +85°C	3.2 x 2.5 mm	1.8 ~ 3.3 V	Clipped Sine
FOX923CH Series	8.192 MHz ~ 32.768 MHz	± 2.5 PPM	-30°C ~ +85°C	3.2 x 2.5 mm	3.3 V	HCMOS
FOX914 SERIES	8 MHz ~ 40 MHz	± 2.5 PPM	-30°C ~ +85°C	5 x 3.2 mm	1.8 ~ 3.3 V	Clipped Sine
FOX924 SERIES	8 MHz ~ 34 MHz	± 2.5 PPM	-30°C ~ +85°C	5 x 3.2 mm	3.3 V	HCMOS
FOX331 SERIES	10 MHz ~ 26 MHz	± 0.28 PPM	-20°C ~ +70°C -40°C ~ +85°C (Option)	7 x 5 mm	3.3 V	HCMOS
FXTC-HE72 Series	750 kHz ~ 180 MHz	± 5, ± 2.5, ± 1.5, ± 1 PPM	0°C ~ +70°C; -40°C ~ +85°C (Option)	7 x 5 mm	2.5 V	HCMOS
FXTC-HE73 Series	750 kHz ~ 250 MHz	± 5, ± 2.5, ± 1.5, ± 1 PPM	0°C ~ +70°C; -40°C ~ +85°C (Option)	7 x 5 mm	3.3 V	HCMOS
FXTC-LE72 Series	750 kHz ~ 1 GHz	± 5, ± 2.5, ± 1.5, ± 1 PPM	0°C ~ +70°C -40°C ~ +85°C (Option)	7 x 5 mm	2.5 V	LVDS
FXTC-LE73 Series	750 kHz ~ 1.35 GHz	± 5, ± 2.5, ± 1.5, ± 1 PPM	0°C ~ +70°C -40°C ~ +85°C (Option)	7 x 5 mm	3.3 V	LVDS
FOX801LF Series	10 MHz ~ 50 MHz	± 2.5 PPM	0°C ~ +70°C	11.4 x 9.6 mm	3 V, 3.3 V, or 5 V	Clipped Sine
FOX801BHCLF Series	10 MHz ~ 56 MHz	± 2.5 PPM	0°C ~ +70°C	11.4 x 9.6 mm	3 V, 3.3 V, or 5 V	HCMOS
OCXOs						
Part Number	Frequency Range	Frequency Stability	Temperature Range	Package	Voltage Operation	Output
FHS301/501 Series	5 MHz ~ 80 MHz	± 250 PPB	-30°C ~ +75°C	8 Pin Half Dip / Low Profile	3.3 V or 5V	Clipped Sine or HCMOS
FTS310 Series	2.43 MHz ~ 60 MHz	± 250 PPB	-40°C ~ +65°C -40°C ~ +85°C (Option)	14 Pin DIP	3.3 V	HCMOS/TTL
FTS301/501 Series	10 MHz ~ 40 MHz	± 250 PPB	0°C ~ +70°C -20°C ~ +70°C (Option)	14 Pin DIP	3.3 V or 5V	HCMOS/TTL
FTC Series	1 MHz ~ 100 MHz	± 10, ± 20, ± 50 PPB	0°C ~ +70°C -40°C ~ +75°C (Option)	1 in x 1 in	5 V	Clipped Sine or HCMOS
FTE Series	5 MHz ~ 50 MHz	± 7, ± 10, ± 15 PPB	0°C ~ +70°C -40°C ~ +75°C (Option)	36 x 27.2 mm Euro Package	5 V	Clipped Sine or HCMOS
FTM301AH	5 MHz ~ 40 MHz	± 10, ± 20, ± 50 PPB	0°C ~ +70°C -40°C ~ +85°C (Option)	25.4 x 22.1 mm SMD	3.3V	HCMOS

These products represent only a portion of Fox's TCXO AND OCXO portfolio. For the most complete and current engineering data available, please visit www.foxonline.com

Quartz-Crystal and SAW Oscillators

FEATURES

- Output frequencies from 4 MHz up to 133 MHz
- ± 50 ppm tolerance
- < 30 ps cycle-to-cycle jitter @ 3.3 V
- 400 μ s start-up time
- Operating voltage from 1.8 V to 3.3 V
- LVCMOS output
- Variety of ultra-small packages, down to 2.5 x 2.0 mm
- Wide range of operating temperatures

BENEFITS

- Ultra-low power consumption
- Pin-compatible to industry standard packages
- No aging effects on performance
- No sensitivity to shock and vibration
- Ultra-low power consumption
- Fewer Components = simpler BOM
- Short lead time
- Fast ramp to production

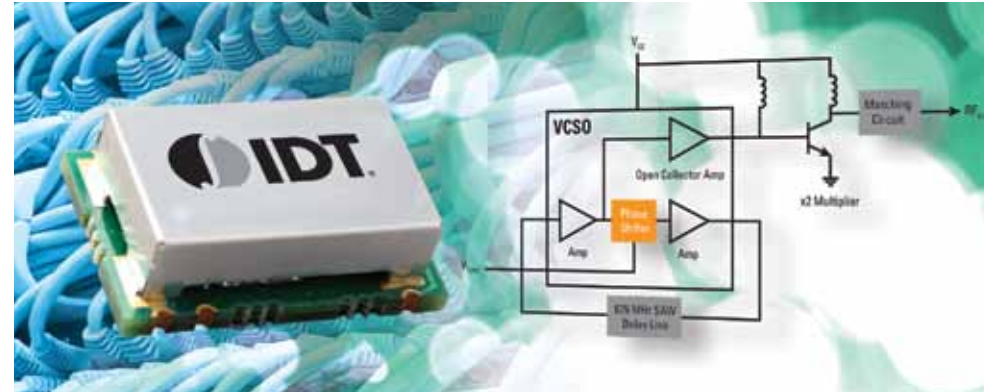

Quartz-Crystal Oscillators — FemtoClock® NG 5mm x 7mm devices are clock frequency sources that provide frequencies from 15.48 to 1300 MHz. Each device features a set of up to four user defined frequencies that are pre-programmed from the factory. An additional I²C programming interface allows access to internal PLL registers for reconfiguring the output frequency. The VCXO devices also allow configuration of the absolute pull-range (APR) from ± 7.5 to ± 757.5 ppm. Compatible with the standard 6-pin 5mm x 7mm ceramic package, these devices are an ideal alternative to classic oscillators, SO, VCXOs and VCSOs, with the additional benefit of a 4-pin interface for output frequency programming. The devices use standard outputs such as differential LVPECL, LVDS and single ended LVCMOS. These devices can be ordered with integrated crystals with an accuracy of ± 20 , ± 50 or ± 100 ppm.

SAW Oscillators — These devices are available in 5 x 7 mm hermetically sealed ceramic surface mount packages that incorporate the oscillator IC and the SAW delay in the package. Standard output frequencies, from 100 MHz to 900 MHz, are readily available. The high-Q quartz SAW delay lines that control the frequency of the VCSOs yield low phase noise and jitter, as well as an extremely stable frequency, over the operating temperature range. The VCSOs are well suited for high performance phase-locked loop circuits such as jitter attenuation and frequency translation, as well as other timing applications in telecom and optical networking systems.

Part Number	# of Outputs	Output Type	Output Frequency Range (MHz)	Supply Voltage (V)	VCO Gain Typ. (ppm/V)	Phase Noise Typ RMS (ps)	Phase Noise Max RMS (ps)	Frequenc Accuracy Total (\pm ppm)	Abs. Pull Range Min. (\pm PPM)	Package Type
M665	1	LVPECL	622.08 - 693.483	3.3	400	0.16	N/A	± 100	± 120	6-CLCC
M675	1	LVPECL	155.52 - 693.483	3.3	400	0.36	N/A	± 100	± 100	6-CLCC
M675S02	1	LVPECL	622.08 - 873.8115	3.3	330	0.155	N/A	± 120	± 120	6-CLCC
M685	1	LVPECL	622.08 - 707.3527	3.3	400	0.16	N/A	± 100	± 120	6-CLCC
M695SDM	1	LVC MOS	1968.75	5	165	0.02	N/A	N/A	± 50	6-CLCC
M690SDM	1	LVC MOS	1747.030837 - 1748.793733	5	340	0.25	N/A	± 300	± 100	6-ld Board
8N3Q001	1	LVPECL	15.476 - 866.67, 975 - 1300	2.5, 3.3	N/A	0.475	0.99	± 63	± 100	10-CLCC
8N4Q001	1	LVDS	15.476 - 866.67, 975 - 1300	3.3	N/A	0.24	0.39	± 113	± 100	10-CLCC
8N3QV01	1	LVPECL	15.476 - 866.67, 975 - 1300	2.5	10	0.475	0.757	± 33	± 4.5	10-CLCC
8N4QV01	1	LVDS	15.476 - 866.67, 975 - 1300	3.3	7.57	0.475	0.757	± 63	± 4.5	10-CLCC
8N3DV85	1	LVPECL	15.476 - 866.67, 975 - 1300	3.3	7.57	0.44	0.71	± 113	± 12.5	10-CLCC
8N3S270	1	LVPECL	15.476 - 866.67, 975 - 1300	3.3	N/A	0.474	0.986	± 63	± 100	10-CLCC
8N3SV75	1	LVPECL	15.476 - 866.67, 975 - 1300	3.3	7.57	0.44	0.66	± 33	± 4.5	10-CLCC
8N4DV85	1	LVDS	15.476 - 866.67, 975 - 1300	2.5	10	0.46	0.63	± 63	± 4.5	6-CLCC
8N0Q001	1	LVC MOS	15.476 - 260	3.3	N/A	0.4	N/A	± 63	± 100	10-CLCC
8N4S270	1	LVDS	15.476 - 866.67, 975 - 1300	3.3	N/A	0.5	N/A	± 113	± 100	10-CLCC

These products represent only a portion of IDT's Quartz-Crystal and SAW Oscillator portfolio. For information on additional devices, please visit www.idt.com/timing/oscillators

CrystalFree™ Piezo MEMS (pMEMS™) Oscillators and Crystal Replacements



IDT CrystalFree Piezo MEMS (pMEMS™) Oscillator technology is transforming the frequency control market. Combining the advantages of piezoelectric quartz with the advantages and reliability of silicon MEMS resonators, IDT's pMEMS resonator technology combines the strong electromechanical coupling of the piezoelectric material with the stability and low damping of single crystal silicon to create a passive frequency source of unparalleled performance and reliability. Based on over 40 patents (granted or filed), IDT's CrystalFree pMEMS resonators are the world's smallest hermetically-sealed wafer level package (WLP) resonators

MEMS oscillators are rapidly replacing legacy quartz based oscillators. By adopting standard semiconductor processes and high volume plastic packaging, IDT has significantly improved upon the lead time and availability of oscillator procurement. Utilizing MEMS processing and fabrication, delivery concerns that have plagued the quartz industry for decades is no longer an issue. With full factory configurability, standard as well as custom frequencies can now ship within 3 to 4 weeks of order placement.

FEATURES

- Short Lead Times
 - Enables Just-In-Time inventory management
 - Next day sampling
- Standard Differential Outputs
 - LVDS, LVPECL
- Small packages down to 2 x 1.6 mm for space-constrained designs
- Low Phase-Jitter
 - < 1 ps rms (12k to 20MHz)
- Frequency Stability
 - ±50 ppm (-40 to 85°C)
- Ultra-low power consumption of about 2 mA

BENEFITS

- Up to 75% Power Savings when replacing XOs with CrystalFree Oscillators
- Semiconductor grade reliability offering shock and vibration resistance
- Frequency stability appropriate for most consumer, computing and storage applications
- The world's smallest hermetically-sealed wafer level package (WLP) resonators
- Wide temperature ranges to support a wide variety of applications
- Frequency stability appropriate for most consumer, computing and storage applications
- Pin-compatible to industry standard packages
- No aging effects on performance
- Fast start-up time allows frequent power cycles
- Faster time to market
- Short lead times (< 4 weeks)

Part Number	Package Size	Frequency	Output
4MA125000Z3AACUGI	5.0 x 3.2; 7.0 x 5.0 mm	125.0000	LVDS / LVPECL
4MA125000Z3BACUGI	5.0 x 3.2; 7.0 x 5.0 mm	125.0000	LVDS / LVPECL
4MA125000Z4AACUGI	5.0 x 3.2; 7.0 x 5.0 mm	125.0000	LVDS / LVPECL
4MA125000Z4BACUGI	5.0 x 3.2; 7.0 x 5.0 mm	125.0000	LVDS / LVPECL
4MA156250Z3AACUGI	5.0 x 3.2; 7.0 x 5.0 mm	156.2500	LVDS / LVPECL
4MA156250Z3BACUGI	5.0 x 3.2; 7.0 x 5.0 mm	156.2500	LVDS / LVPECL
4MA156250Z4AACUGI	5.0 x 3.2; 7.0 x 5.0 mm	156.2500	LVDS / LVPECL
4MA156250Z4BACUGI	5.0 x 3.2; 7.0 x 5.0 mm	156.2500	LVDS / LVPECL

For additional information, please visit www.idt.com/timing/crystalfree



PARTNER ATTACH GUIDES

Xilinx FPGA	40
Freescale QorIQ	42
Freescale iMX	45
Cavium Designs	46
Altera FPGA	47
Broadcom BCM54382	49
Broadcom Switch/PHY	50
Intel Atom	52



IDT Attach Guide for Xilinx FPGAs

IDT TIMING SOLUTIONS PORTFOLIO

CLOCK GENERATION

- 5x7 Crystal Oscillator, VCXOs
- SAW Oscillator, VCXO Modules
- FemtoClock® and FemtoClock NG
- PLL Synthesizers
- Spread Spectrum Clocks
- QUICClocks
- VCXO + Fanout
- VCXO + FemtoClock

Part Numbers

8N3PN10I	843241	841654I	844N234	810001-21	844031i-01
8N3O001	8413S12	843N252-45	844N236	874003-02	8430-11
8N3QV01	841S101	84xN1611-01	843001-21	874003-05	8442
8T49N Series	871S1022	814S208I	844003I-01	874001-05	844021-01
8T43N Series	8430S10-03	844256-24	8745-21	9DB202	

CLOCK DISTRIBUTION

- Zero Delay Buffers
- Frequency Translation (Dividers & Multipliers)
- Dynamic Clock Switches
- Clock Multiplexers
- Fanout Buffers

Part Numbers

8543	8535I-01	85108I
853S006	85411	5V5218
854S006	853S011	83905
8304	87339-01	8535i-31
8308	85102I	83908-02
85310-01	85104I	83904-02
830154I-08	85105I	83918

JITTER ATTENUATION & FREQUENCY TRANSLATION

- PLL Clock Generators
- VCXO + FemtoClock
- Stratum WAN PLL
- IEEE1588 WAN PLL
- Sync-E Jitter Attenuators
- “Hitless” Switches

Part Numbers

82V3288	810N322-02	813N2532
82V3285	813N322-02	813N2560
82V3280	814322-02	813N252-02
82V3255	82V3388	814N252-02
82V3012/3002	82V3380	813N252-09
82V3011/3001	82V3385	82V3391

Best In-Class Performance

- Low Jitter
- < 0.3 ps rms (FemtoNG™ in Integer mode)
- < 0.5 ps rms (FemtoNG™ in Fractional mode)
- Excellent PSNR (-80dBc)
- Integrated Fanout from 1 to 16 outputs
- 1GHz+ frequency support
- Field-proven standards compliance for IEEE, Telcordia, ITU, DOCSIS, JEDEC and others

Widest Selection of Densities and I/O

- Output densities from 1 to 44
- High performance fan-out buffers with speeds up to 3GHz
- Universal inputs support any logic type with AC or DC coupling
- LVPECL, LVDS, HCSL and HSTL output support
- LVCMOS (1.2V, 1.5V, 1.8V, 2.5V, 3.3V)
- Mixed voltage support
- Designed for tight timing budgets – optimized for low skew, delay, jitter
- Low additive jitter < 0.09 ps
- Low output Skew < 15 ps
- Propagation delays below 500ps

Synchronization enabling products for TDM and Wireless Infrastructure

- 1 PPS input and output
- SONET OC-12/48/192
- 10/40/100 GbE
- IEEE-1588 and Sync-E compliant clocks
- I/O frequency range from 1KHz to 900MHz
- Multiple FEC rate conversion
- Excellent wander and jitter performance
- Selectable Loop Bandwidth
- EEC-Option 1, EEC-Option 2, Stratum 3, SMC, 4E and 4 (ITU-T G.8262, ITU-T G.813, GR-253-CORE, and GR-1244-CORE)
- Automatic hitless switching on failure
- Phase Build Out and Phase slope limiting support

IDT has the industry’s broadest portfolio of timing solutions, supporting many Networking and Communication applications. With products that uniquely complement Xilinx designs, IDT provides the performance, design expertise, reliability and delivery necessary to achieve design success. IDT’s PLL-based clock generators and high performance fanout buffers offer sub picosecond jitter, low-skew clock outputs, and edge rates that meet the input specifications of Xilinx’s existing and next generation FPGA products.

IDT TECHNOLOGY DIFFERENTIATORS

- World leader in Silicon Timing
- Largest portfolio of devices with differential levels: LVPECL, LVDS, HCSL, HSTL
- Specializing in very low jitter for wireless infrastructure, SDH/SONET, Ethernet, PCIe, storage, instrumentation, phase-noise sensitive systems
- Largest portfolio of devices with mixed I/Os, voltage levels and frequencies
- Established design wins with major communication equipment manufacturers

Interconnect Protocol	Line Rate (Gbps)	Xilinx FPGA Family	Clock Generation		Clock Distribution	Level Translation	Jitter Attenuation & Frequency Translation
			Reference Clocks	Ref Clocks with Integrated Fanout			
1 GbE	1.25	Spartan 6 Virtex 4 / 5 / 6 / 7 Artix 7, Kintex 7	8N3PN10I	8T49N & 8T43N Series 8535I-31, 83905, ICS843001-21, ICS8442, ICS844031-01, ICS844021-01, ICS844003I-01	8304 830154I-08 8535I-01	85411 853S011 830S21	810251
40GbE 100GbE	10.3125	Virtex 6 HXT Virtex 7, Kintex 7	8N3PN10I 8N3O001(XO) 8N3OV01(VCXO)	8T49N Series 8T43N Series 843003-01	87339-01, 8308, 854S006, 8543, 830154I-08, 8535I-01	85411 853S011 830S21	849N202
PCIe Gen1 Gen2	2.5 5.0	Spartan 6 Virtex 4 / 5 / 6 / 7, Artix 7, Kintex 7	841S101 8N3PN10I	8T49N & 8T43N Series 8413S12, 8430S10-03 871S1022, 874003-02 874003-05, 874001-05	85102I, 85104I 85105I, 85108I	85411 853S011 830S21	874003-02, 874003-05 874001-05, 871S1022
PCIe Gen3	8	Virtex 6 HXT Virtex 7, Kintex 7	841S101 8N3PN10I	8T49N & 8T43N Series 841S104 / 102	85102I, 85104I 85105I, 85108I	85411 853S011 830S21	874001-05 874003-05
Serial RapidIO	1.25, 2.5 3.125, 5, 6.25	Spartan 6 Virtex 4 / 5 / 6 / 7, Artix 7, Kintex 7	8N3PN10I	8T49N & 8T43N Series 844N255, 8413S12 843N252-45, ICS843001-21	8543, 853S006, 854S006, 8304, 8308, 830154I-08, 8535I-01	85411 853S011 830S21	849N202
Fibre Channel	1.0625 2.125, 4.25 8.5, 10.52	Virtex 4 / 5 / 6 / 7, Artix 7, Kintex 7	8N3PN10IMDKI-020LF	8T49N & 8T43N Series 8535I-31, 83905	8543, 853S006, 854S006, 8304, 8308, 830154I-08, 8535I-01	85411 853S011 830S21	849N202
SAS / SATA	1.5, 3.0 6.0	Virtex 5 / 6 / 7, Artix 7, Kintex 7	843241 8N3PN10	8T49N & 8T43N Series 843256, 844256	8543, 853S006, 854S006, 8304, 8308, 830154I-08, 8535I-01	85411 853S011 830S21	849N202
10GbE XAUI	3.125	Spartan 6 Virtex 4 / 5 / 6 / 7, Artix 7, Kintex 7	8N3PN10I 8N3O001(XO) 8N3OV01(VCXO)	8T49N & 8T43N Series, 844N255, 8413S12, 843N252-45, ICS843001-21 ICS844003I-01	8543, 853S006, 854S006, 8304, 8308, 830154I-08, 8535I-01	85411 853S011 830S21	849N202
10GbE XFI	10.3125	Virtex 6 HXT Virtex 7 Kintex 7	8N3PN10I 8N3O001(XO) 8N3OV01(VCXO)	8T49N Series 8T43N Series	8543, 853S006, 854S006, 8304, 8308, 830154I-08, 8535I-01	85411 853S011 830S21	849N202
SONET OC-48 OC-192	2.488 9.953	Virtex 6 HXT Virtex 7 Kintex 7	8N3PN10I 8N3O001(XO) 8N3OV01(VCXO)	8T49N & 8T43N Series 843256, 844256, ICS843001-21	8543, 853S006, 854S006, 8304, 8308, 830154I-08, 8535I-01	85411 853S011 830S21	82V3391, 82V3390, 82V3399, 82V3395, 82V3380, 82V3355, 82V3288, 82V3285, 82V3280, 82V3255, 810N322-02, 813N322-02, 813N322-02, 814N322-02
OTN OTU-2	10.709	Virtex 6 HXT Virtex 7 Kintex 7	8N3PN10I 8N3O001(XO) 8N3OV01(VCXO)	8T49N Series 8T43N Series	8543, 853S006, 854S006, 8304, 8308, 830154I-08, 8535I-01	85411 853S011 830S21	82V3391, 82V3390, 82V3399, 82V3395, 82V3380, 82V3355, 82V3288, 82V3285, 82V3280, 82V3255, 810N322-02, 813N322-02, 813N322-02, 814N322-02
OTN OTU-3 OTU-4	43.018 112	Virtex 6 HXT Virtex 7 Kintex 7	8N3PN10I 8N3O001(XO) 8N3OV01(VCXO)	8T49N Series 8T43N Series	8543, 853S006, 854S006, 8304, 8308, 830154I-08, 8535I-01	85411 853S011 830S21	82V3391, 82V3390, 82V3399, 82V3395, 82V3380, 82V3355, 82V3288, 82V3285, 82V3280, 82V3255, 810N322-02, 813N322-02, 813N322-02, 814N322-02
CPRI	0.6144, 1.2288, 2.4876, 3.072, 4.9152, 6.144, 9.8304	Spartan 6 Virtex 4 / 5 / 6 / 7 Artix 7, Kintex 7	84xN161I-01 84xN161I-04	8T49N and 8T43N Series, 814S208, 844256-24, 844N234, 844N236	85310-01 853S9252	85411 853S011 830S21	819N422I-01 819N432I
Video 3G-SDI HD-SDI Genlock	13.5, 14.3181818, 16.9344, 27, 27.027, 54, 67.5, 74.175824, 74.25, 106.25, 125 (MHz)	Spartan 6 Virtex 4/5/6/7	1574BMLF 8N3O011(XO) 662M-05 663M 664G-01	664G-02 664G-05 660 1526GILF	8543 853S006 854S006 8304 8308	85411 853S011 830S21	849N202

IDT Attach Guide for Freescale™ QorIQ

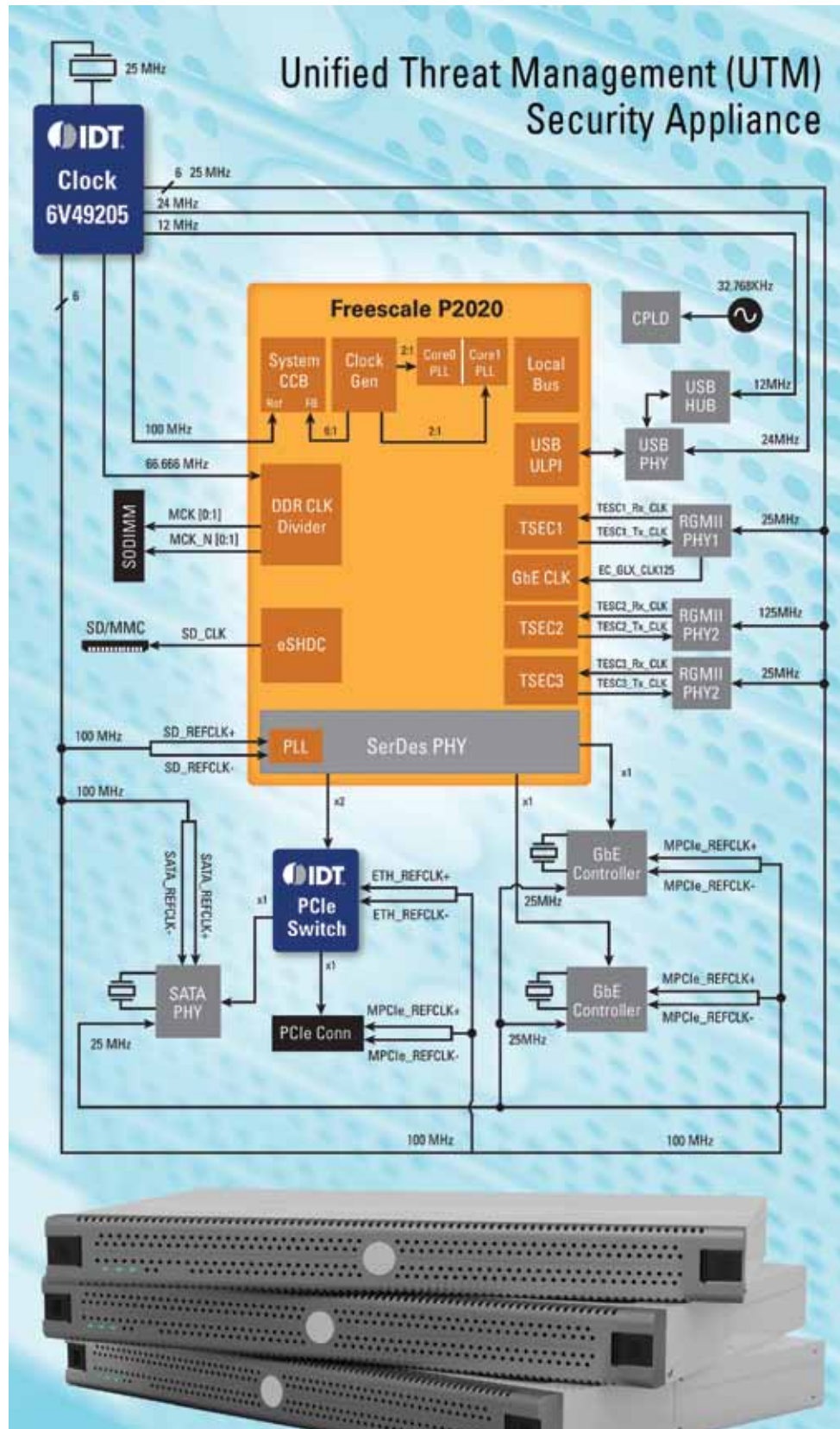

IDT has the industry's broadest portfolio of timing solutions for Industrial, Networking, Consumer and Embedded applications. With products uniquely complimenting Freescale's QorIQ processors, IDT provides the performance, flexibility, design expertise, reliability and manufacturing capabilities to ensure customer success.

INTEGRATED CLOCK GENERATION

- Spread-Spectrum Capable for EMI reduction
- Highly-integrated single-chip solutions replace up to:
 - 11 Crystals
 - 2 Oscillators
 - 3 clock synthesizers
- Low-power PCIe outputs with integrated terminations
- PCIe Gen1/2/3 compliant PCIe outputs
- < 3ps RMS for 125M outputs
- Programmable Slew Rate
- As little as 400mW power dissipation

BUILDING BLOCK CLOCK GENERATION

- SERDES clocks support PCIe Gen3 and up to 10G XAU1
- Mix and match various clocks as long as the desired frequency and data rate are supported
- Supports HCSL, LP-HCSL, LVPECL, LVDS, LVCMOS, LVTTTL signaling standards
- Low-Power HCSL outputs reduce power consumption by as much as 30mW per output compared to standard HCSL devices

CLOCK DISTRIBUTION

- Zero Delay/Fan out Buffers
- Clock multiplexers

Selecting clocks for QorIQ designs is straightforward. Once the “Qor” clocking requirements of the Freescale QorIQ processors are satisfied (SYS_CCB clock, etc.), product selection proceeds to other required clocks, such as USB or 25M for Ethernet. Then, the number of, the frequencies of and the desired data rates of the SERDES links are factored into the clock selection. IDT offers both integrated and building block approaches to QorIQ timing solutions as shown in the Product Selector Tables.

QorIQ Devices: P1 and P2 Series

CLOCK GENERATION	“Qor” Clocks			SERDES Clock Pairs			Other Clocks	
Part Number	SYS_CCB (MHz)	DDR_CLK (MHz)	GTX_CLK (MHz)	Pairs (MHz)	Standards	Data Rates (Gb/s)	USB_CLK (MHz)	Other Outputs (MHz)
6V49205B	1x 66.7 / 80 / 83.3 / 100 / LVCMOS / LVTTTL	1x 66.7 LVCMOS / LVTTTL	1x 125 LVCMOS / LVTTTL	6x 100 LP-HCSL1	PCIe G1/G2, SGMII, sRIO 1x / 2x SATA / SATA3G	1.25 / 2.5 / 5 / 1.5 / 3	2 x 12 / 24 LVCMOS / LVTTTL	6 x 25 REF 2 x 2.048 LVCMOS / LVTTTL
CLOCK GENERATION	“Qor” Clocks			SERDES Clock Pairs			Other Clocks	
Part Number	SYS_CCB (MHz)	DDR_CLK (MHz)	GTX_CLK (MHz)				Other Outputs (MHz)	
840S07	3x 33.33, 50, 66.67 / 83.33 / 100 / 125 / 133.33 / 166.67 LVCMOS / LVTTTL		1x 33.33, 50, 66.67 / 83.33 / 100 / 125 / 133.33 / 166.67 LVCMOS / LVTTTL				-	
MPC9855	3x 66.67 / 83.33 / 100 / 133.33 / 166.67 / 200 LVCMOS / LVTTTL		3x 133.33 / 166.67 / 200 LVCMOS / LVTTTL				2x 25 REF LVCMOS / LVTTTL	

CLOCK GENERATION	SERDES Clock Pairs			Other Clocks
Part Number	Pairs (MHz)	Standards	Data Rates (Gb/s)	Other Outputs (MHz)
5V41144	8x 100 / 125 / 156.25 / HCSSL	PCIe G1/G2, SGMII 1x / 2.5x, sRIO 1x / 1.25x / 2x, SATA / SATA3G, XAUI	1.25 / 2.5 / 3.125 / 5 / 1.5 / 3	1x 25 REF LVCMOS / LVTTTL
5V41145	4x 100 / 125 / 156.25 / HCSSL		1.25 / 2.5 / 3.125 / 5 / 1.5 / 3	1x 25 REF LVCMOS / LVTTTL
9FGL839	8x 100 LP-HCSL		1.25 / 2.5 / 3.125 / 5 / 1.5 / 3	-
8T49N222A-ddd (ddd= 100, 101, 102,...119)	2x 100/ 125 / 156.25 / 312.5 LVPECL / LVDS	PCIe G1/G2, SGMII 1x / 2.5x, sRIO 1x / 1.25x / 2x, SATA / SATA3G, XAUI, XAUI 10G	1.25 / 2.5 / 3.125 / 5 / 10 / 1.5 / 3	-
8413S12	10x 100/ 125 / 156.25 / 312.5 HCSSL		1.25 / 2.5 / 3.125 / 5 / 10 / 1.5 / 3	1x 25 REF / 1x 50 REF LVCMOS / LVTTTL

QorIQ Devices: P3, B4, P4, T4, P5 Series

CLOCK GENERATION	“Qor” Clocks			Other Clocks	
Part Number	SYS_CCB (MHz)	DDR_CLK (MHz)	GTX_CLK (MHz)	USB_CLK (MHz)	Other Outputs (MHz)
840NT4	4x 66.67 / 100 / 125 / 133.33 LVCMOS / LVTTTL	4x 66.67 / 100 / 125 / 133.33 LVCMOS / LVTTTL	-	-	1x 25 REF, 1x 3.125 / 1.5625 LVCMOS / LVTTTL
840NT4-01	-	-	8x 125 LVCMOS / LVTTTL	1x 24 LVCMOS / LVTTTL	1x 25 REF

CLOCK GENERATION	SERDES Clock Pairs		
Part Number	Pairs (MHz)	Standards	Data Rates (Gb/s)
849N202	2x Any Rate, LVDS/ LVPECL Outputs fOUT= 0.98 to 1,300	PCIe G1/G2, SGMII 1x/2.5x, sRIO 1x/1.25x/2x SATA/SATA3G, XAUI, XAUI 10G	1.25 / 2.5 / 3.125 / 5 / 10 / 1.5 / 3
8T49N222A-ddd (ddd = 100, 101, 102, ...119)	2x Any Rate Independently Selectable LVDS/ LVPECL Outputs, fOUT = 7.72 to 875		

* LP-HCSL are Low-Power HCSL-compatible Differential Outputs

Non-PLL Fanout Buffers and Muxes

Part Number	Input Qty	Input Type	Output Qty	Output Type	Frequency (MHz)	Standards	Data Rates (Gb/s)
6V31021	1 DIF	HCSL	4 DIF	LP-HCSL*	15 - 167	PCIe G1/G2/G3, SGMII 1x/2.5x, sRIO 1x/1.25x/2x SATA/SATA3G, XAUI, XAUI 10G	1.25 / 2.5 / 3.125 / 5 / 10, 1.5 / 3
85104	1 SE / 1 DIF	LVPECL / LVDS / LVHSTL / HCSL / SSTL or LVCMOS / LVTTTL	4 DIF	HCSL	0 - 500		1.25 / 2.5 / 3.125 / 5 / 10; 1.5 / 3"
853S011C	1 DIF	ECL / LVPECL / LVDS / CML / SSTL	2 DIF	LVPECL / ECL	0 - 2500		1.25 / 2.5 / 3.125 / 5 / 10; 1.5 / 3
6V31023	2 DIF	HCSL	1 DIF	HCSL	0 - 200		1.25 / 2.5 / 3.125 / 5 / 10; 1.5 / 3
8535-01	2 SE	LVCNOS/LVTTTL	4 DIF	LVPECL	0-266		1.25 / 2.5 / 3.125 / 5 / 10; 1.5 / 3
830154AGI-08	1 SE	1.8-3.3V; LVCMOS/LVTTTL	4 SE	1.8-3.3V; LVCMOS/LVTTTL	0-160	N/A	N/A

PLL Differential Buffers and Jitter Attenuators (all devices can be configured as fanout buffer with PLL bypassed)

Part Number	Input Qty	Input Type	Output Qty	Output Type	Frequency (MHz)	Standards	Data Rates (Gb/s)
9DB433	1 DIF	HCSL	4 DIF	HCSL	5 - 166	PCIe G1/G2/G3, sRIO 1x/2x SATA/SATA3G	2.5 / 5/8; 1.5 / 3"
9DB833	1 DIF	HCSL	8 DIF	HCSL	5 - 166		
871S1022	1 DIF/ 1 XTAL	LVPECL / LVDS / LVHSTL / HCSL	4 DIF	HCSL	125 / 100 / 250 / 500	PCIe G1/G2/G3, SGMII 1x/2.5x, sRIO 1x/1.25x/2x SATA/SATA3G, XAUI, XAUI 10G	1.25 / 2.5 / 3.125 / 5 / 8 / 10; 1.5 / 3.0 (SATA)
849N202	2 DIF/ 1 XTAL	LVPECL / LVDS / LVHSTL / HCSL	2 DIF	LVPECL / LVDS	0.98 to 1,300		

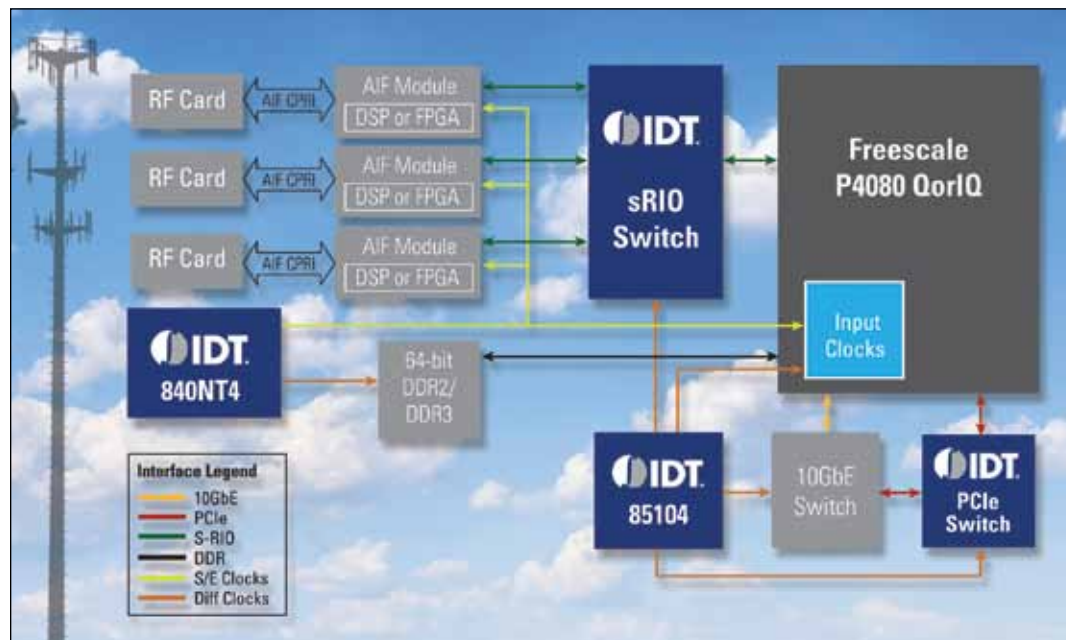

SERDES Data Rates vs Protocols

SERDES Data Rates (Gb/s)	SERDES Protocols
1.25	SGMII
1.5	SATA
2.5	PCIe G1; sRIO
3	SATA
3.125	2.5x SGMII; sRIO; XAUI
5	PCIe G2, sRIO
8	PCIe G3
10	XAUI 10G

IDT has the industry's broadest portfolio of timing solutions, supporting applications in communications, computing and consumer markets. With products that uniquely complement Freescale™ i.MX designs, IDT provides the design expertise, reliability and delivery necessary to achieve design success. The following information identifies current IDT timing solutions for Freescale i.MX designs.

KEY BENEFITS

- Increased integration
- Reduced crystal and oscillator count
- Reduced board space and Part count
- Better availability and lead times
- Low jitter and skew
- Very low Active and Standby power
- Reduced total cost
- Selectable frequencies for different applications
- Small 4mm x 4mm footprint
- Spread spectrum and LVDS output capability for EMI reduction
- Full 1.8V core with 1.8V to 3.3V IO minimizes power and eliminates need for level translation

TARGET MARKETS & APPLICATIONS

- eBooks
- Smartbooks
- Tablets
- Personal Navigation Devices

RELATED IDT PRODUCTS

- 1894K-32LF 10/100 Ethernet PHY
- LDS61xx Capacitive Touch Buttons with LED Control
- LDS62xx Capacitive Touch Buttons with Proximity Sense
- ACS52201 Audio Codec w/ HiPerf Amp
- ACS422x00 Audio Codec w/ HiPerf Class D Amp

IDT Versaclock LP Attach Guide for Freescale i.MX Designs

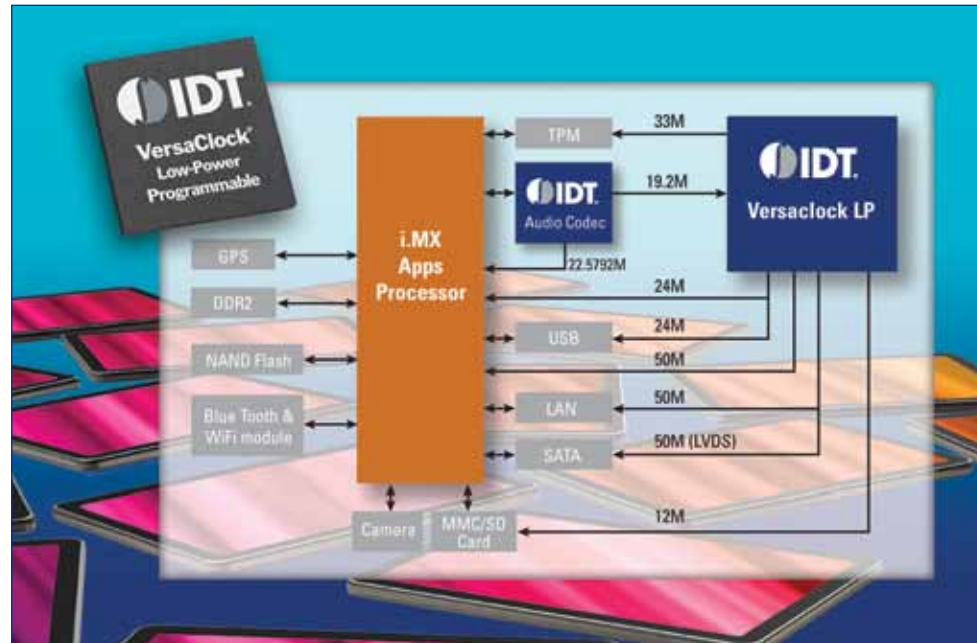

Freescale i.MX Typical Application Diagram

Part Number	Input Type	# of Outputs	Output Type	VDDO	Package	i.MX Processor Family	Target Applications
5P49EE502	MHz TCXO, ICLK, Crystal	5	LVC MOS	1.8-3.3V	20-pin 3x3mm QFN	i.MX233 i.MX257 i.MX353 i.MX515	Ebooks
5P49EE505	MHz TCXO, ICLK, Crystal	5	LVC MOS/ Buffered Sine Wave	1.8-3.3V	20-pin 3x3mm QFN		
5P49EE601	MHz, ICLK, Crystal, 32.768kHz	6	LVC MOS / LVDS	1.8-3.3V	24-pin 4x4mm QFN		
5P49EE602	MHz, ICLK, Crystal, 32.768kHz	6	LVC MOS	1.8-3.3V	24-pin 4x4mm QFN		
5P49EE605	MHz, ICLK, Crystal, 32.768kHz	6	LVC MOS/ Buffered Sine Wave	1.8-3.3V	24-pin 4x4mm QFN		
5P49EE801	MHz, ICLK, Crystal, 32.768kHz	8	LVC MOS / LVDS	1.8-3.3V	28-pin 4x4mm QFN	i.MX233 i.MX31 i.MX353 i.MX355 i.MX515	Smartbooks, Tablets, Portable Navigation Devices
5P49EE802	MHz, ICLK, Crystal, 32.768kHz	8	LVC MOS	1.8-3.3V	28-pin 4x4mm QFN		
5P49EE805	MHz, ICLK, Crystal, 32.768kHz	8	LVC MOS/ Buffered Sine Wave	1.8-3.3V	28-pin 4x4mm QFN		

IDT Attach Guide for Cavium Designs

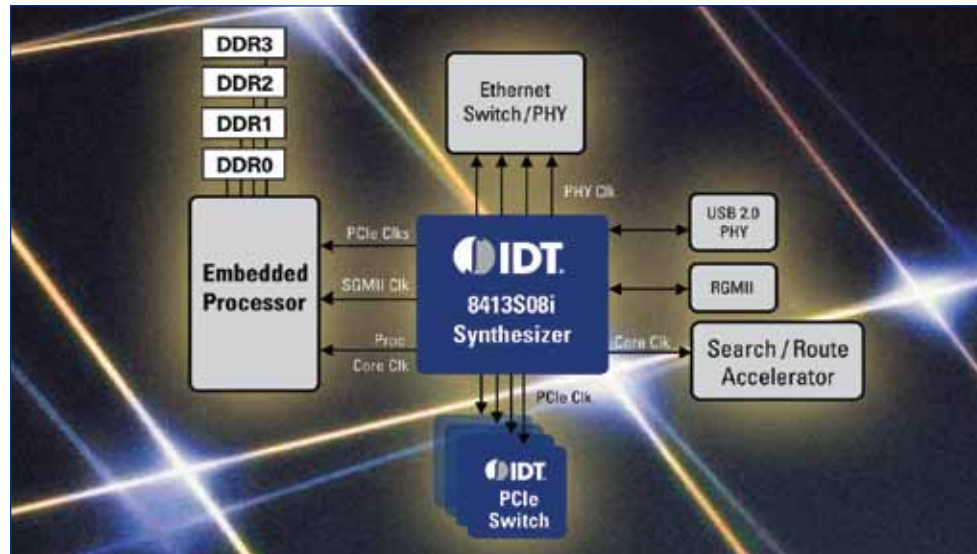

Networking / Communication Example

IDT Part Number	Reference Clock Outputs & Frequencies	Cavium Processor	Target Applications
8413S12I	PCIe/sRIO/XAUI/10GbE ref clocks: 100MHz, 125MHz, 156.25MHz, or 312.5MHz (x10 copies) Processor ref clock: 50MHz Single-ended (S/E) ref clocks: 25MHz (2x copies) & 125MHz (1x copy)	CN6xxx Series CN68xx CN67xx CN63xx	Secure datacenters, mobile internet, and borderless enterprise applications
8305I	RGMII fanout ref clocks: 125MHz (x4 copies)		
841N4830I	HCSL ref clocks: 100MHz (x3 diff) S/E ref clock: 100MHz Selectable S/E ref clock: 50MHz or 100MHz Diff ref clock: 25MHz		
841654I	PCIe and/or sRIO ref clocks: 100MHz or 125MHz (x4) S/E ref clock: 25MHz		
8413S08I	PCIe and sRIO ref clocks: 100MHz or 125MHz (x8 copies) SGMII ref clock: 156.25MHz Processor Core clock: 33.3MHz or 50MHz Single-ended GbE PHY ref clock: 25MHz Diff GbE PHY ref clock: 25 MHz (x3 copies)	CN5xxx Series CN58xx CN57xx CN56xx CN55xx CN54xx CN52xx CN50xx	Networking and storage equipment, including routers, switches, triple-play gateways, WLAN and 3G/4G access, storage arrays, storage networking equipment, servers, and intelligent NICs
8413S12I	PCIe/sRIO/XAUI/10GbE ref clocks: 100MHz, 125MHz, 156.25MHz, or 312.5MHz (x10 copies) Processor ref clock: 50MHz Single-ended (S/E) ref clocks: 25MHz (2x copies) & 125MHz (1x copy)		
8430S10I S8430S10I-02 8430S10I-03	DDR400, DDR533, or DDR667 ref clock: 83.3MHz, 100MHz, 125MHz, 133.3MHz Processor Core clock: 33.3MHz or 50MHz (x2 copies) PCI or PCI-X ref clock: 33.33MHz, 66.67MHz, 100MHz, or 133.33MHz SPI4.2 ref clock: 80MHz, 100MHz, 125MHz, or 400MHz (x2 copies) Gigabit Ethernet MAC ref clock: 125MHz GbE PHY clocks: 25MHz (x3 copies)		
840S06 840S07I	Processor Core clock: 33.3MHz or 50MHz PCI or PCI-X ref clock: 33.33MHz, 66.67MHz, 100MHz, or 133.33MHz Gigabit Ethernet MAC ref clock: 125MHz GbE PHY clocks: 25MHz (x3 copies)	CN3xxx Series CN38xx CN36xx CN31xx CN30xx	Intelligent, multi-gigabit networking, control plane, storage, and wireless applications
8430S07I 8430S07I-02	DDR400, DDR533, or DDR667 ref clock: 83.3MHz, 100MHz, 125MHz, 133.3MHz Processor Core clock: 33.3MHz or 50MHz PCI or PCI-X ref clock: 33.33MHz, 66.67MHz, 100MHz, or 133.33MHz GbE PHY ref clock: 25MHz (x3 copies) Gigabit Ethernet MAC: 125MHz		

IDT has the industry's broadest portfolio of timing solutions, supporting applications in communications, computing and consumer markets. With products that uniquely complement Cavium designs IDT provides the design expertise, reliability and delivery necessary to achieve design success. The following information identifies current IDT timing solutions for Cavium designs.

KEY BENEFITS

- Integrated solution optimized for Cavium Processors
- Low Jitter and skew meets Cavium requirements
- Phase noise of <0.8ps RMS (12k to 20M)
- Reduced Total Cost
- Reduced board space and Part count
- Better availability and lead times (4-8 weeks)
- Selectable frequencies for different processors
- Small foot print 5mm X 5mm
- LVPECL and LVCMOS output levels
- Full 3.3V or mixed 3.3V/2.5V operation mode

TARGET MARKETS & APPLICATIONS

- Networking
- Communication
- Computing
- System clock for Cavium NPU
- PCI Express® Switches
- Ethernet PHYs
- Search Accelerator

RELATED IDT PRODUCTS

- 8430S07
- 8430S07-02
- 8413S08
- 8430S10
- 8430S10-02
- 8430S10-03
- IDT PCIe Switches

IDT has the industry's broadest portfolio of timing solutions. With products that uniquely complement Altera designs, IDT provides the performance, design expertise, reliability and delivery necessary to achieve design success. IDT's PLL-based clock generators and high performance fanout buffers offer sub picosecond jitter, low-skew clock outputs, and edge rates that meet the input specifications of Altera's existing and next generation FPGA products.

TECHNOLOGY DIFFERENTIATORS

- World leader in Silicon Timing
- Largest portfolio of devices with differential levels: LVPECL, LVDS, HCSL, HSTL, CML
- Specializing in very low jitter for wireless infrastructure, SDH/SONET, Ethernet, PCIe, storage, instrumentation, phase-noise sensitive systems
- Largest portfolio of devices with mixed I/Os, voltage levels and frequencies
- Established design wins with major communication equipment manufacturers

IDT Attach Guide for Altera FPGAs

CLOCK GENERATION

- 5x7 XO & SO
- Modules
- XO + Fanout
- FemtoClocks™
- PLL Synthesizers
- SSC Clocks
- QUICCclocks
- VCXO + Fanout
- VCXO + FemtoClock
- VCSO Modules

Part Numbers

8N3PN10I	843241	841654I	84xN161I-04
8N3Q001	8413S12	8535I-31	840S2306I
8N3QV01	841S101	83905	
8T49N Series	871S1022	843N252-45	
8T43N Series	8430S10-03	84xN161I-01	

Best In-Class Performance

- Low Jitter
 < 0.3 ps rms (FemtoNG™ in Integer mode)
 < 0.5 ps rms (FemtoNG™ in Fractional mode)
- Excellent PSNR (-80dBc)
 – Integrated Fanout from 1 to 16 outputs
 – 1GHz+ frequency support
- Field-proven standards compliance for IEEE, Telcordia, ITU, DOCSIS, JEDEC and others

CLOCK DISTRIBUTION

- Zero Delay Buffers
- Programmable Skew
- Frequency Translation (Dividers & Multipliers)
- Dynamic Clock Switches
- Clock Multiplexers
- Fanout Buffers

Part Numbers

2305	830154I-08	85108I
2308	8535I-01	5V5201
8543	85411	5V5206
853S006	853S011	5V5216
854S006	87339-01	5V5218
8304	85102I	8CA3052
8308	85104I	8CA3054-01
85310-01	85105I	

Widest Selection of Densities and I/O

- Output densities from 1 to 44
- High performance fan-out buffers with speeds up to 3GHz
- Universal inputs support any logic type with AC or DC coupling
- LVPECL, LVDS, MLVDS, LVTTTL, HCSL and HSTL output support
- LVCMOS (5V, 3.3V, 2.5V, 1.8V)
- Mixed voltage support
- Designed for tight timing budgets – optimized for low skew, delay, jitter
- Low additive jitter < 0.09 ps
- Low output Skew < 15 ps
- Propagation delays below 500ps (SiGe)

JITTER ATTENUATION & FREQUENCY TRANSLATION

- PLL Clock Generators
- VCXO + FemtoClock
- VCSO + PLL Modules
- Stratum WAN PLL
- IEEE1588 WAN PLL
- Sync-E Jitter Attenuators
- “Hitless” Switches

Part Numbers

82V3288	82V3155	810N322-02
82V3285	82V3012/3002	813N322-02
82V3280	82V3011/3001	814322-02
82V3255	82V3203A/B	

Synchronization enabling products for TDM and Wireless Infrastructure

- 1 PPS input and output
- SONET OC-12/48/192
- 10/40/100 GbE
- IEEE-1588 and Sync-E compliant clocks
- I/O frequency range from 1KHz to 900MHz
- Multiple FEC rate conversion
- Excellent wander and jitter performance
- Selectable Loop Bandwidth
- EEC-Option 1, EEC-Option 2, Stratum 3E, 3, SMC, 4E and 4 (ITU-T G.8262, ITU-T G.813, GR-253-CORE, and GR1244-CORE)
- Automatic hitless switching on failure
- Phase Build Out and Phase slope limiting support

Interconnect Protocol	Line Rate (Gbps)	Altera FPGA Family	Clock Generation		Clock Distribution	Level Translation	Jitter Attenuation & Frequency Translation
			Reference Clocks	Ref Clocks with Integrated Fanout			
1 GbE	1.25	Stratix V, Stratix IV, Arria V, Arria II, Cyclone V, Cyclone IV, Cyclone IV GX	8N3PN10I	8T49N Series 8T43N Series 8535I-31, 83905	8304 830154I-08 8535I-01	85411 853S011 830S21	810251
40GbE 100GbE	10.3125	Stratix V, Stratix IV GT	8N3PN10I 8N3Q001(XO) 8N3QV01(VCXO)	8T49N Series 8T43N Series 8535I-31, 83905	87339-01, 8308, 854S006, 8543, 830154I-08, 8535I-01	85411 853S011 830S21	849N202
PCIe Gen1 Gen2	2.5 5.0	Stratix V, Stratix IV, Arria V, Arria II	841S101 8N3PN10I 871S1022	8T49N & 8T43N Series, 8413S12, 8430S10-03, 8535I-31, 83905	851021, 851041 851051, 851081	85411 853S011 830S21	874003-02 871S1022
PCIe Gen3	8	Stratix V, Stratix IV	841S101 8N3PN10I 871S1022	8T49N Series 8T43N Series 8535I-31, 83905	85102I, 85104I 85105I, 85108I	85411 853S011 830S21	874003-02
Serial RapidIO	1.25, 2.5 3.125, 5 6.25	Stratix V, Stratix IV, Arria V, Arria II, Cyclone V GX Cyclone IV GX	8N3PN10I	8T49N & 8T43N Series, 8413S12, 8430S10-03, 841654I, 8535I-31, 83905	8543, 853S006, 854S006, 8304, 8308, 830154I-08, 8535I-01	85411 853S011 830S21	849N202
Fibre Channel	1.0625 2.125, 4.25 8.5, 10.52	Stratix V, Stratix IV Arria V, Arria II	8N3PN10MDKI-020LF	8T49N Series 8T43N Series 8535I-31, 83905	8543, 853S006, 854S006, 8304, 8308, 830154I-08, 8535I-01	85411 853S011 830S21	849N202
SAS/ SATA	1.5, 3.0 6.0	Stratix V, Stratix IV, Arria V, Arria II	843241 8N3PN10	8T49N Series 8T43N Series 8535I-31, 83905	8543, 853S006, 854S006, 8304, 8308, 830154I-08, 8535I-01	85411 853S011 830S21	849N202
10GbE XAUI	3.125	Stratix V, Stratix IV, Arria V, Arria II, Cyclone V, Cyclone IV Cyclone IV GX	8N3PN10I 8N3Q001(XO) 8N3QV01(VCXO)	8T49N Series 8T43N Series 8535I-31, 83905	8543, 853S006, 854S006, 8304, 8308, 830154I-08, 8535I-01	85411 853S011 830S21	849N202
10GbE XFI	10.3125	Stratix V Stratix IV GT, Arria V, Arria II	8N3PN10I 8N3Q001(XO) 8N3QV01(VCXO)	8T49N Series 8T43N Series 8535I-31, 83905	8543, 853S006, 854S006, 8304, 8308, 830154I-08, 8535I-01	85411 853S011 830S21	849N202
SONET OC-48 OC-192	2.488 9.953	Stratix V Stratix IV Arria V Arria II	8N3PN10I 8N3Q001(XO) 8N3QV01(VCXO)	8T49N Series 8T43N Series 8535I-31 83905	8543, 853S006, 854S006, 8304, 8308, 830154I-08, 8535I-01	85411 853S011 830S21	82V3288, 82V3285, 82V3280, 82V3255, 82V3155, 82V301 2/3002, 82V3011/3001, 810N322-02, 813N322-02, 813N322-02, 814N322-02
OTN OTU-2	10.709	Stratix V Stratix IV GT Arria V Arria II	8N3PN10I 8N3Q001(XO) 8N3QV01(VCXO)	8T49N Series 8T43N Series 8535I-31 83905	8543, 853S006, 854S006, 8304, 8308, 830154I-08, 8535I-01	85411 853S011 830S21	82V3288, 82V3285, 82V3280, 82V3255, 82V3155, 82V301 2/3002, 82V3011/3001, 810N322-02, 813N322-02, 813N322-02, 814N322-02
OTN OTU-3 OTU-4	43.018 112	Stratix V Stratix IV Arria V Arria II	8N3PN10I 8N3Q001(XO) 8N3QV01(VCXO)	8T49N Series 8T43N Series 8535I-31 83905	8543, 853S006, 854S006, 8304, 8308, 830154I-08, 8535I-01	85411 853S011 830S21	82V3288, 82V3285, 82V3280, 82V3255, 82V3155, 82V301 2/3002, 82V3011/3001, 810N322-02, 813N322-02, 813N322-02, 814N322-02
CPRI	0.6144, 1.2288, 2.4876, 3.072, 4.9152, 6.144, 9.8304	Stratix V, Stratix IV, Arria V, Arria II, Cyclone V GX Cyclone IV GX	843N252-45, 84xN161I-01, 84xN161I-04, 840S2306I, 840S2316I, 840S2326I	819N422I-01 819N432I 844S012I	85310-01, 5V5201, 5V5206, 5V5216, 5V5218	85411 853S011 830S21	82V3216, 82V3218, 82V3288, 82V3280, 82V3255, 82V3203A/B
Video 3G-SDI HD-SDI Genlock	13.5, 14.3181818, 16.9344, 27, 27.027, 54, 67.5, 74.175824, 74.25, 106.25, 125 (MHz)	Arria IV, Arria II, Cyclone V Cyclone IV	1574BMLF 8N3Q011(XO) 662M-03 663M 664G-01	664G-02 664G-05 660 1526GILF	8543 853S006 854S006 8304 8308	85411 853S011 830S21	849N202

IDT CLOCK SYNTHESIZER SOLUTION

IDT8R834242I clock synthesizer and the IDT8R89S212I clock multiplexer/buffer uniquely complement the Broadcom BCM54382 to 10/100/1000 Base-T Ethernet Transceiver designs. The IDT8R834242I is a flexible timing solution that provides excellent phase noise performance necessary to support 1GE applications. For applications that require precise and accurate synchronization, the IDT8R89S212I provides low propagation delay and ultra-low additive phase jitter of a recovered system clock. As the leader in timing solutions, IDT provides the performance, design expertise, reliability and delivery necessary to achieve design success.

APPLICATIONS

- Enterprise
- Data Center
- Industrial Power
- Smart Grid Automation

IDT SOLUTIONS FOR BCM54382

IDT8R834242I

- Two 3.3V differential LVPECL output pairs
- Using a 31.25MHz or 26.041666 crystal, the two output banks can be independently set for 625MHz, 312.5MHz, 156.25MHz or 125MHz
- Crystal oscillator interface
- VCO range: 560MHz to 700MHz
- RMS phase jitter @ 625MHz (1.875MHz - 20MHz): 0.4ps (typical)

IDT8R89S212I

- High speed 2:1 differential multiplexer with a 1:2 fanout buffer
- Two differential LVPECL or LVDS output pairs
- Part-to-part skew: 25ps (typical)
- Propagation delay: 555ps (typical)
- Additive phase jitter, RMS: 0.16ps (typical)

IDT Attach Guide for Broadcom BCM54382

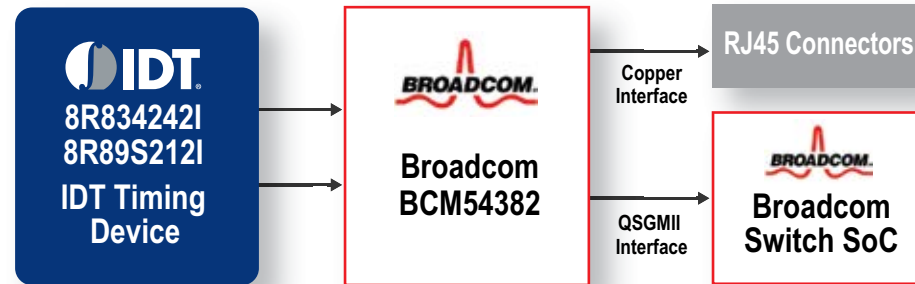

IDT8R834242I CLOCK SYNTHESIZER SOLUTION

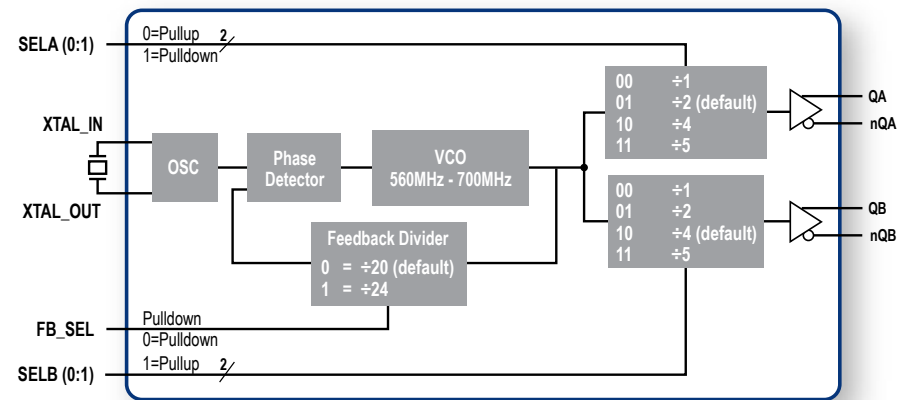

IDT8R89S212I CLOCK RECOVERY SOLUTION

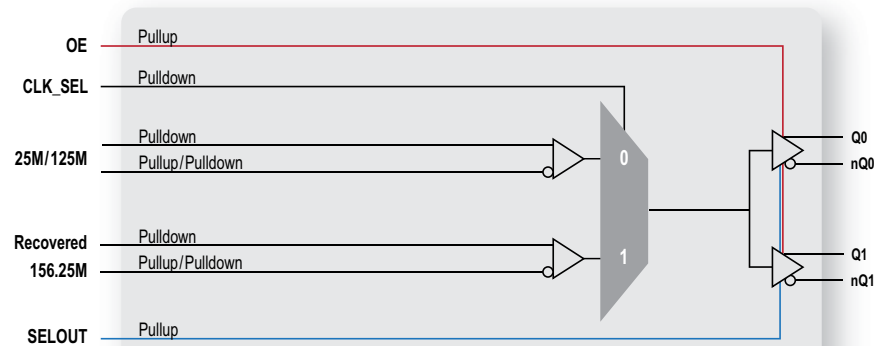

Synchronous Ethernet Attach Guide for Broadcom Switch/PHY

IDT SOLUTION FOR BCM 56640

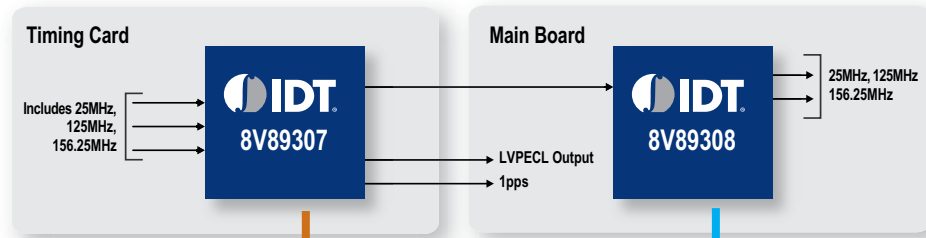

8V89307 BLOCK DIAGRAM

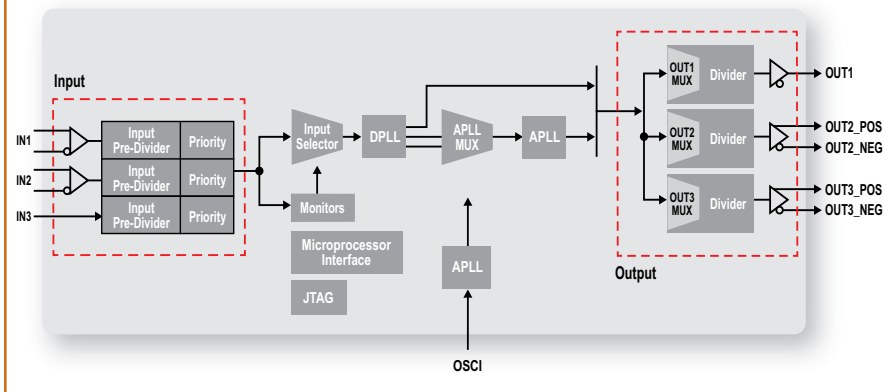

8V89308 BLOCK DIAGRAM

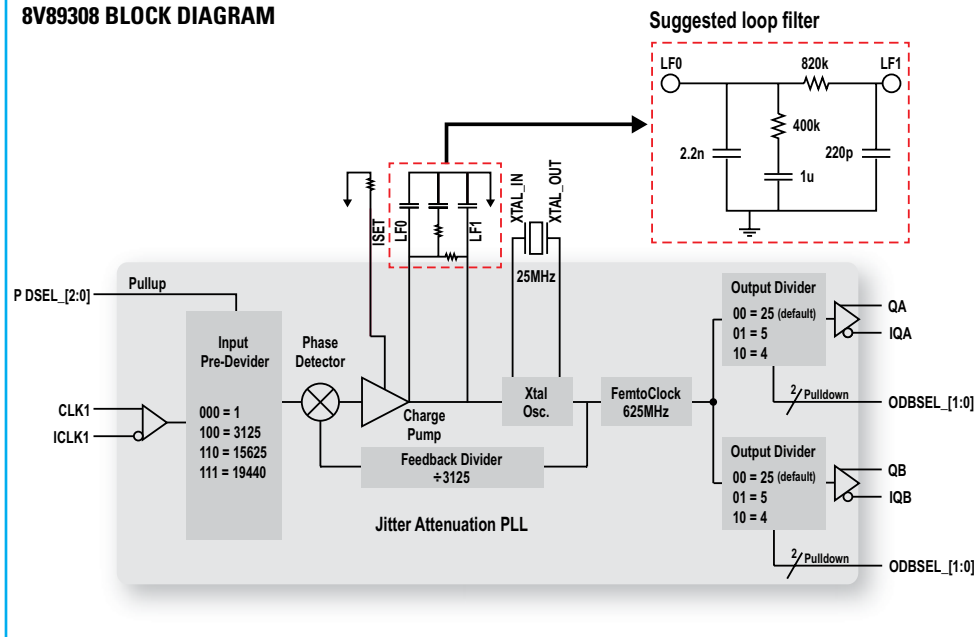

BROADCOM SWITCH/PHY REFERENCE DESIGNS

- BCM 56640
- BCM 56440 / 56441 / 56442 / 56443
- BCM 56445 / 56448
- BCM 88650
- BCM 88030
- BCM 56842 / 56844 / 56846
- BCM 56850

IDT SYNCHRONOUS ETHERNET SOLUTIONS

The IDT **8V89307 + 8V89308** clocking solution uniquely complements Broadcom Switch/PHY SyncE designs. The IDT 8V89307 + 8V89308 clocking solution fully supports the requirements laid out in ITU-T G.8262 for synchronous Ethernet Equipment Clocks and it meets the stringent phase noise requirements of 10GE/40GE SyncE applications.

IDT provides the performance, design expertise, reliability and delivery necessary to achieve design success.

IDT SOLUTION FOR BCM 56640

8V89307 + 8V89308

- Input frequencies: 10MHz – 156.25MHz
- Output frequencies: 1pps, 25MHz, 125MHz, 156.25MHz
- RMS jitter: <0.3ps
- Aligns outputs to reference input phase with offset control
- Automatic hitless switching with less than 0.61ns transient
- Automatic switching between free-run, locked, holdover
- I²C or SPI interface control
- IEEE 1149.1 JTAG Boundary Scan

BROADCOM SWITCH/PHY REFERENCE DESIGNS

- BCM 56640
- BCM 56440 / 56441 / 56442 / 56443
- BCM 56445 / 56448
- BCM 88650
- BCM 88030
- BCM 56842 / 56844 / 56846
- BCM 56850

IDT SYNCHRONOUS ETHERNET SOLUTIONS

The IDT 8V89307 is a flexible clocking solution that fully supports the requirements laid out in ITU-T G.8262 for synchronous Ethernet Equipment Clocks and it meets the tight phase noise requirements of Broadcom Switch/PHY 1GE applications. No other external components are needed to achieve 1GE requirements.

IDT has a wide portfolio of fanout buffers to complement different design requirements to fanout multiple copies of the clock.

IDT has long been a leader in wireline market space. IDT has a complete portfolio of T1/E1/J1 products such as Line Interface Units (LIU), transceivers and framers. To support TDM in this reference design, designers can choose from T1/E1 LIU in different number of port counts that can support long- and short-haul, and also short-haul only applications.

IDT SOLUTION FOR BCM 56440 / 56441 / 56442 / 56443

8V89307

- Input frequencies: 10MHz – 156.25MHz
- Output frequencies: 1pps, 25MHz, 125MHz, 156.25MHz
- 8V89307 will meet Broadcom requirements without jitter attenuator for 1GE applications

BUFFERS

8S898311

- 1:4 Differential-to-LVPECL Fanout Buffer

853S0061

- 1:6 Differential to LVPECL Fanout buffer

Based on individual design requirements

For a complete selection of IDT Buffers, visit idt.com/go/clocks

IDT SOLUTION FOR BCM 56440 / 56441 / 56442 / 56443

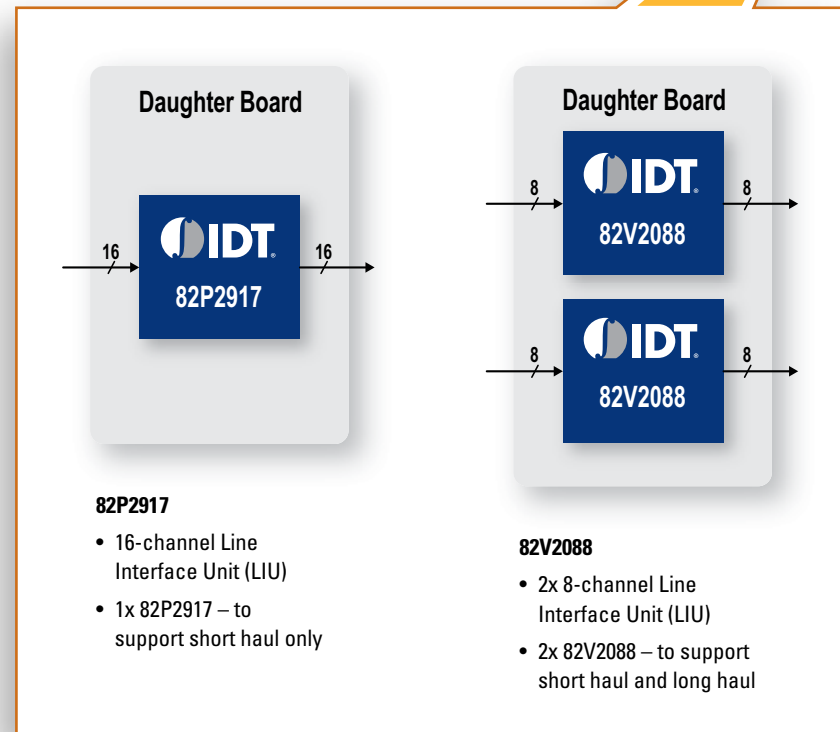
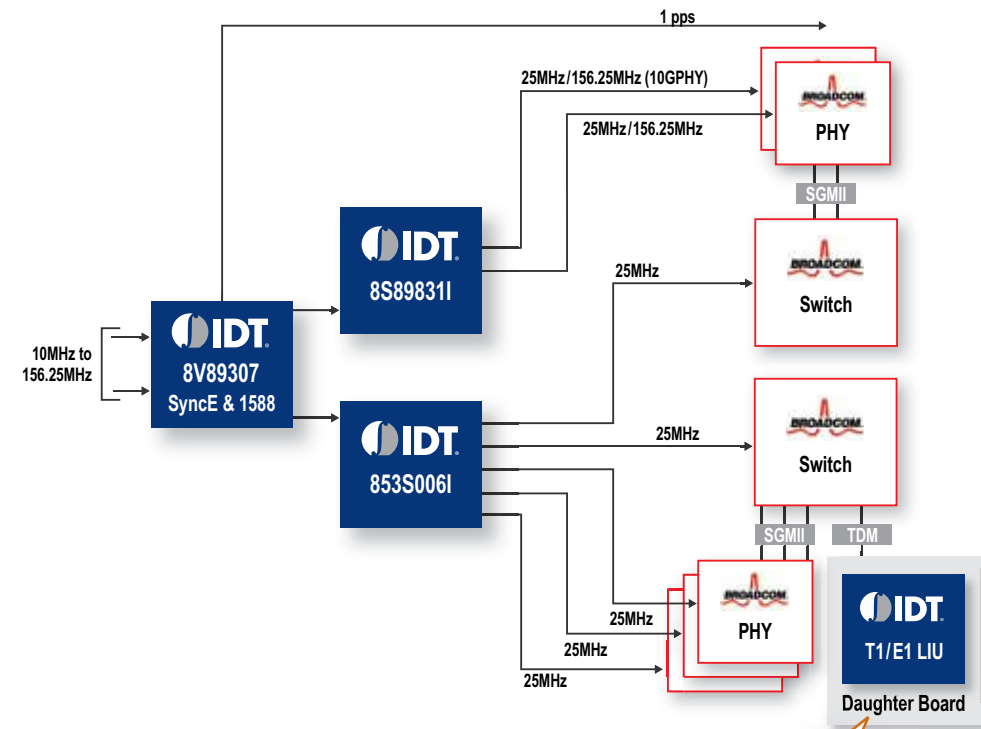

82P2917

- 16-channel Line Interface Unit (LIU)
- 1x 82P2917 – to support short haul only

82V2088

- 2x 8-channel Line Interface Unit (LIU)
- 2x 82V2088 – to support short haul and long haul

IDT Attach Guide for Atomic* Clocks

*Clocks for Intel Atom-Based Embedded Systems

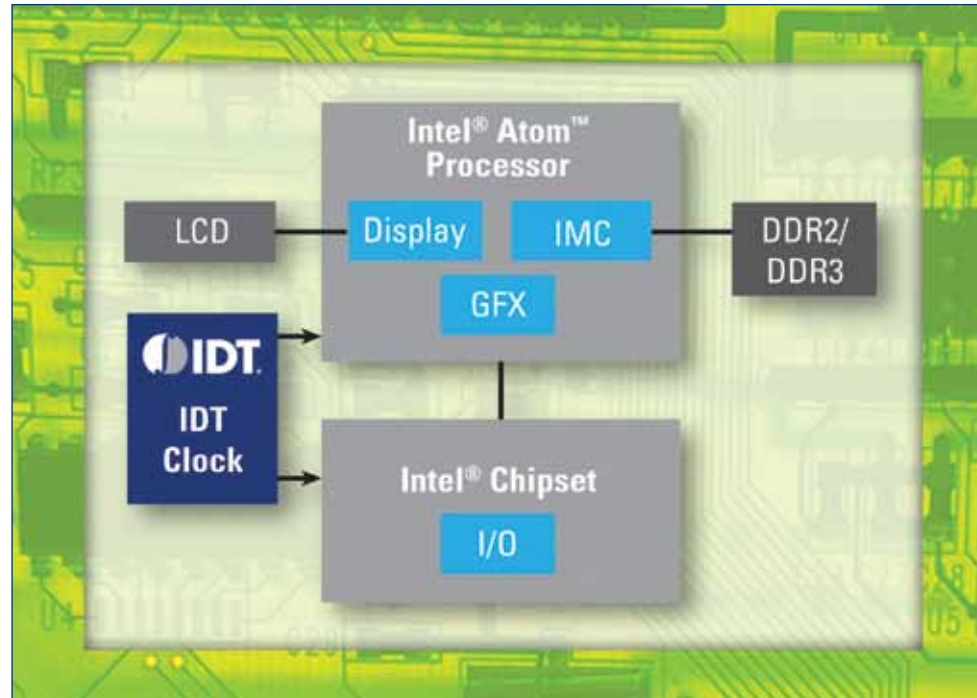

Typical Application Diagram

Small Desktop	Atom 230/330 (Diamondville) 9UMS9001 (CK540) 9UMS9610 (CK610) 9UMS9633 (CK633) 9LPRS525 (CK505)	Atom D4xx, D5xx Series (Tunnel Creek) 9LPRS436 (CK505 derivative) 9LPS525 (CK505)	Atom N26xx, N28xx Series (Cedarview) 9VRS4338 (CK-NET) 9VRS4339 (CK-NET derivative) 9LPRS525 (CK505) 9DBL411 (Optional low power PCIe fanout buffer)
Small Notebook (Netbook)	Atom N270/N280 (Diamondville) 9UMS9001 (CK540) 9UMS9610 (CK610) 9UMS9633 (CK633)	Atom D4xx, D5xx Series (Tunnel Creek) 9LPRS436 (CK505 derivative) 9LPS525 (CK505)	
Embedded (including Industrial temp, Automotive)	Atom N270/N280 (Diamondville) 9UMS9633 (CK633)	Atom E6xx Series (Tunnel Creek, Stellarton) 9LPRS436 (CK505 derivative) 9LPS525 (CK505)	Atom N26xx, N28xx Series (Cedarview) 9VRS4338 (CK-NET) 9LPRS436 (CK505 derivative) 9LPRS525 (CK505) 9DBL411 (Optional low-power PCIe fanout buffer)
Mobile Internet Devices (Ultra Mobile PC)	Atom Z5xx, Z6xx Series (Silverthorn, Lincroft) 9UMS9001 (CK540) 9UMS9610 (CK610)	Moorsetown HE Smartphones Lincroft SOC (45nm) Langwell I/O PCH (65nm) Custom PMIC/SOC	Medfield Custom PMIC/SOC

An enormous number of Internet connected devices use Intel's Atom™ CPU. While some of these devices are in familiar applications, like desktop and notebook PCs, many Atom CPUs are used in embedded applications such as communications equipment, industrial control, automotive In-Vehicle Infotainment (IVI), and micro-servers. IDT has the industry's broadest line of 'Atomic' clocks so that no matter what the application, IDT has the perfect clocking device.

KEY BENEFITS

- Industry's Widest Selection of 'Atomic' Clocks – one-stop-shop for any application
- Industrial temperature grade parts available for systems that must function in demanding environments.
- Automotive AEC Q100 level devices available. Suitable for use in Automotive In-Vehicle Infotainment.
- Integrated series resistors and voltage regulators for differential outputs. Minimal external component count with maximum performance
- PCI Express® Gen 2 on many devices for higher performance and increased system margin.
- VDD_IO rail on many devices for maximum power savings
- 1.5 V core operation on some devices minimizes power consumption.
- Wide range of I/O configurations allows 'right-sizing' the clock to the design, resulting in the smallest footprint device for the application.

TARGET MARKETS & APPLICATIONS

- POS Terminals
- Embedded CPU cards
- Automotive IVI
- Micro-Servers
- Industrial Controllers
- Communication cards
- Internet Kiosks
- Digital Signage
- Home Energy Management
- Medical Instrumentation

Device	9UMS9001	9UMS9610	9UMS9633	9LPRS525	9LPRS436	9VRS4338	9VRS4339
Package	56 MLF ² (8x8mm Body, 0.5mm pin pitch)	48 MLF ¹ (6x6mm Body, 0.4mm pin pitch)	48 MLF ¹ (6x6mm Body, 0.4mm pin pitch) 48SSOP ^{2,3} (300 mil Body, 25 mil pin pitch)	56SSOP ² (300 mil Body, 25 mil pin pitch) 56 TSSOP ² (6.1mm Body, 0.5mm pin pitch)	48 MLF ¹ (6x6mm Body, 0.4mm pin pitch) 48TSSOP ² (6.1mm Body, 0.5mm pin pitch)	48 MLF ¹ (6x6mm Body, 0.4mm pin pitch)	56 MLF ¹ (7x7mm Body, 0.4mm pin pitch)
Core Voltage	3.3 V	1.5 V	3.3 V	3.3 V	3.3 V	1.5 V	1.5 V
Separate VDD_IO rail for power savings	Yes (1.05 to 3.3 V)	Yes (1.5 V)	Yes (1.5 to 3.3 V)	Yes (1.05 to 3.3 V)	No	Yes (1.05 to 1.5 V)	Yes (1.05 to 1.5 V)
Fully integrated Voltage Regulator for VDD_IO	Yes	Yes	Yes	Yes	Yes	Yes	Yes
Integrated Series Resistors on Differential Outputs	Yes	Yes	Yes	Yes	Yes	Yes	Yes
Operating Temperature Range	C	C	C, I, W3	C, I	C, I	C	C
Typical Power Consumption	190mW ⁴	100mW ⁵	215mW ⁶	430mW ⁴	330mw ⁸	125mw ⁷	150mw ⁷
Target Applications	UMPC, Embedded, Portable Internet Devices	UMPC, Portable Internet Devices	Embedded, Industrial, Automotive	Embedded, Desktop, Netbook	Embedded, μServers	Ultrabook, Netbook, Desktop, Embedded, Servers	Ultrabook, Netbook, Desktop
PCIe Phase Noise Capability	Gen1	Gen1	Gen1	Gen2	Gen2	Gen2	Gen2

I/O Mix

	CK540	CK610/CK633	CK505 56-pin	CK505 Derivative	CK-NET	CK-NET Derivative
CPU pairs	2	3	2	2	2	2
SRC pairs	4	3	5	2	3	5
ITP/SRC pair	1 ITP	0	1	1	1	1
DOT96/SRC pair	1 DOT96	1 DOT96	1	1 DOT96	1	1
SATA/SRC pair	0	0	1	1 (SATA = 75 or 100 M)	1	1
LCD/SRC pair	1 LCD	1 LCD	1	0	1 LCD	1 LCD
Single-ended Outputs/SRC pair	0	0	1 muxed (with LCD/SCR pair)	12.288M, 25M	1 PCI/25 M output	1 25 M, 1 PCI/27 M
PCI outputs	3	0	6	2	3	3
USB48 output	1	0	1	2 (1 selectable 12M/48M)	1	2
REF output	1	1	1	1	1	1
CLKREQ#	4	3	6 muxed	3	1 muxed, 1 non-muxed	2 muxed, 1 non-muxed

1. HDI PCB technology required
 2. HDI PCB technology NOT required
 3. 48 SSOP is available in AECQ-100 Level 3 Grade for Automotive Applications
 4. VDD = 3.3 V, VDD_IO = 1.05 V

5. VDD = 1.5 V, VDDREF = 3.3 V, VDD_IO = 1.5 V
 6. VDD = 3.3 V, VDDREF = 3.3 V, VDD_IO = 1.5 V
 7. VDD33 = 3.3 V, VDD=1.5 V, VDD_IO = -1.05 V
 8. VDD = 3.3 V

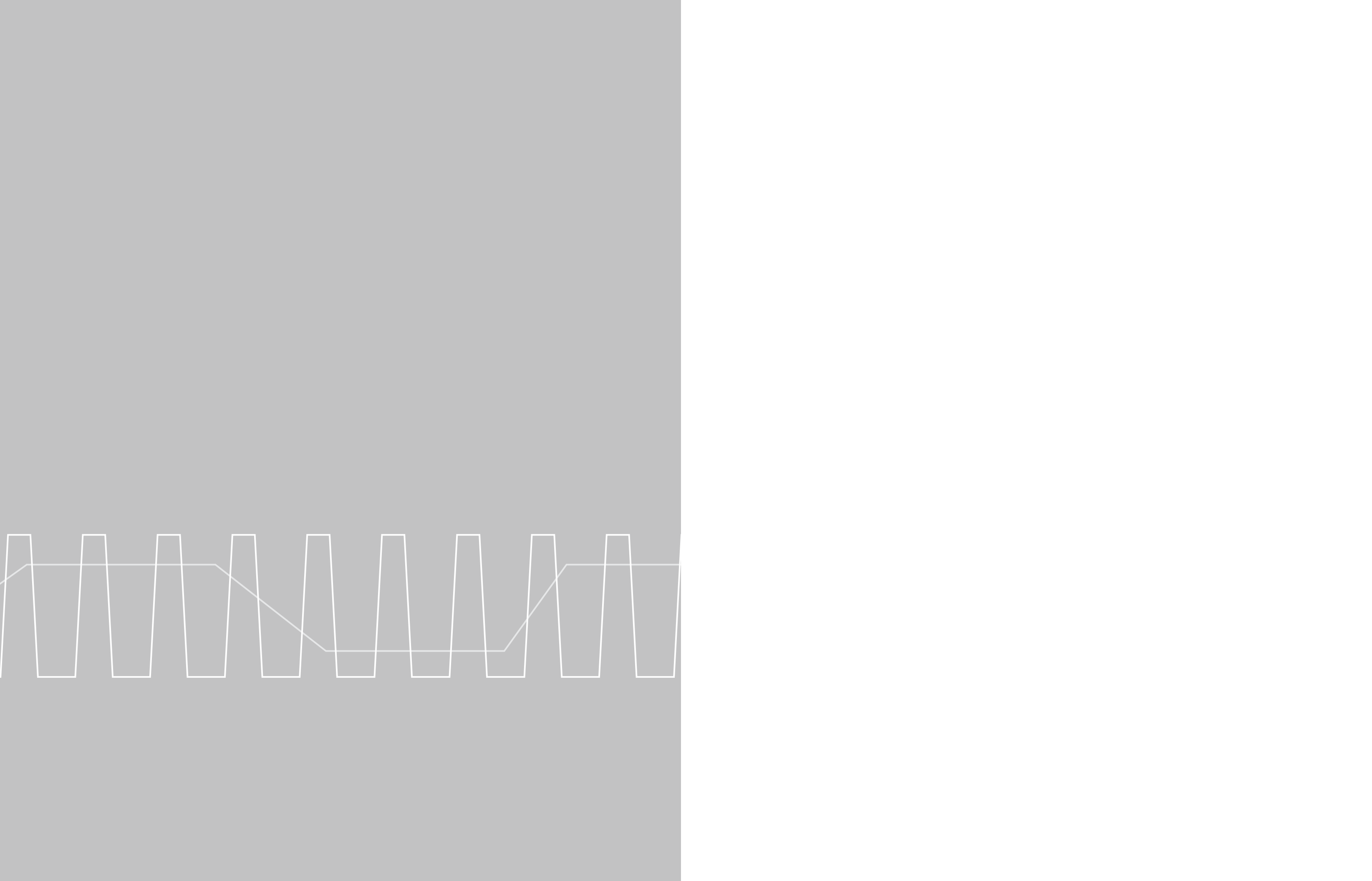

RESOURCES

Clock Solution Customization	56
Part Number Legend	57



Clock Solution Customization

IDT offers an unmatched portfolio of clock solutions for a wide variety of applications. The breadth of offerings provides customers with an off-the-shelf solution for the majority of designs. However, no two designs are the same and some requirements result in the need for optimized solutions to provide differentiation in the market place. Criteria that may dictate the use of a customized clocking solution include aggressive system cost, power dissipation, performance, or board space requirements. IDT provides clock solution customization capabilities and often works with customers to develop customized solutions to address specific needs. IDT's strong regional field applications teams can assist in proposal development for these customized solutions and custom prototype samples are typically available 10-12 weeks from the time specifications are finalized.

The following are some of the available customization options:

- **Supply Voltage:** 1.5V, 1.8V, 2.5V, 3.3V
- **Input/Output levels:** LVDS, LVPECL, HCSL, HSTL, LVCMOS, LVTTTL, DDR
- **Number of outputs**
- **Output Levels**
- **Output frequencies:** up to 3GHz.
- **Electrical performance:** rise time, fall time, duty cycle, jitter performance, skew, propagation delay, low I_{dd}
- **Additional Features:** output enable signals, power down modes, pin selectable frequencies, spread spectrum capability for EMI reduction, I²C or SPI programming, forward error correction (FEC) rates, output reference clocks, frequency margining
- **Packages type:** 8 pin to 144 pin, SOIC, TSSOP, SSOP, QFN etc.
- XO, VCXO and clock input support
- Jitter attenuation, frequency translation and level translation for reference clocks
- On-chip configuration storage via reprogrammable or one time programmable memory

Contact IDT sales to explore the feasibility of customizing your clocking solution.

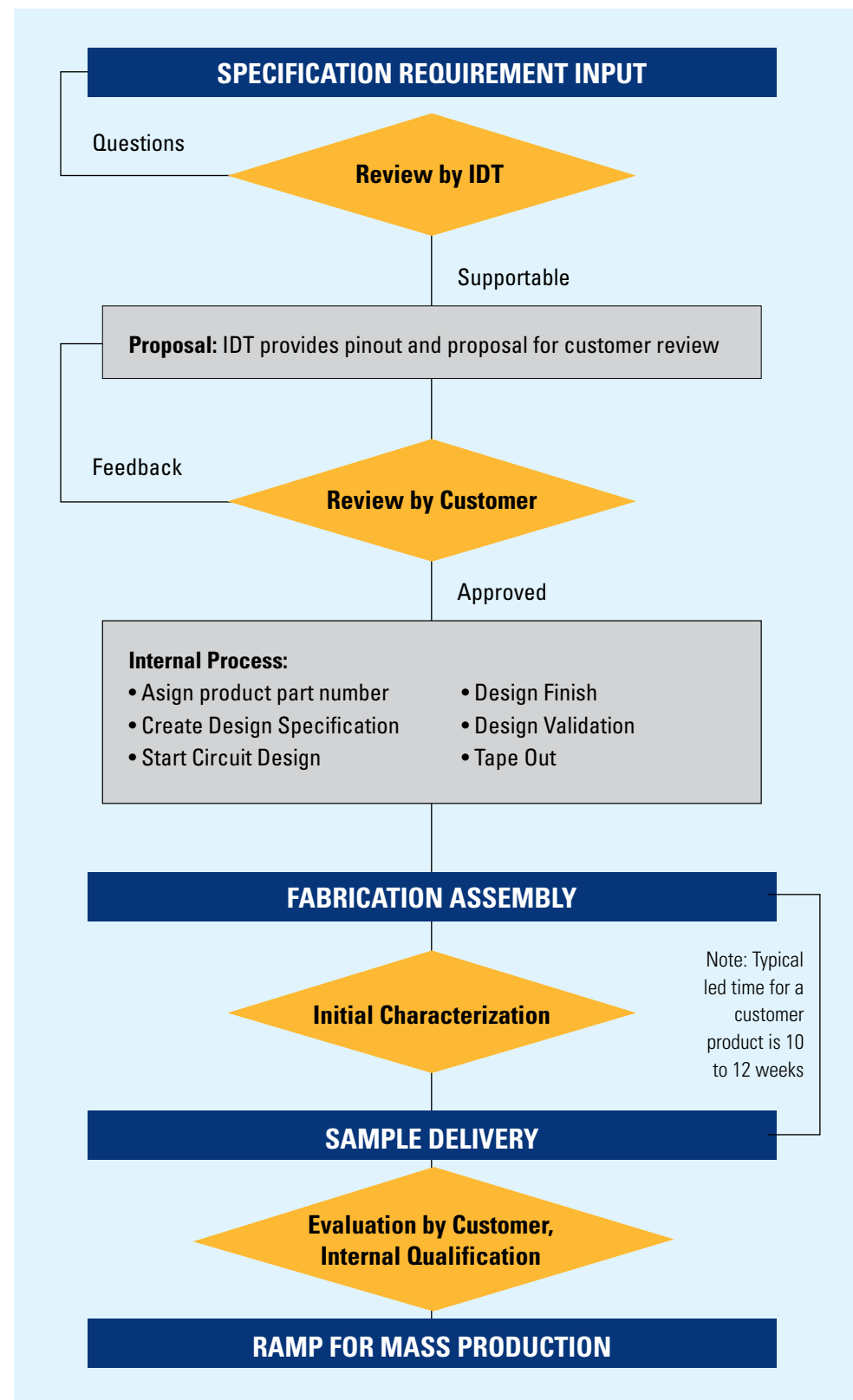

Part Number Legend

There are several part number types in the IDT high-performance clock nomenclature. IDT has acquired product lines from both ICS and Freescale and the established part numbers have been maintained. The clock families can be identified by their marketing part number prefix and are defined in the following charts.

TIMING NOMENCLATURE 1

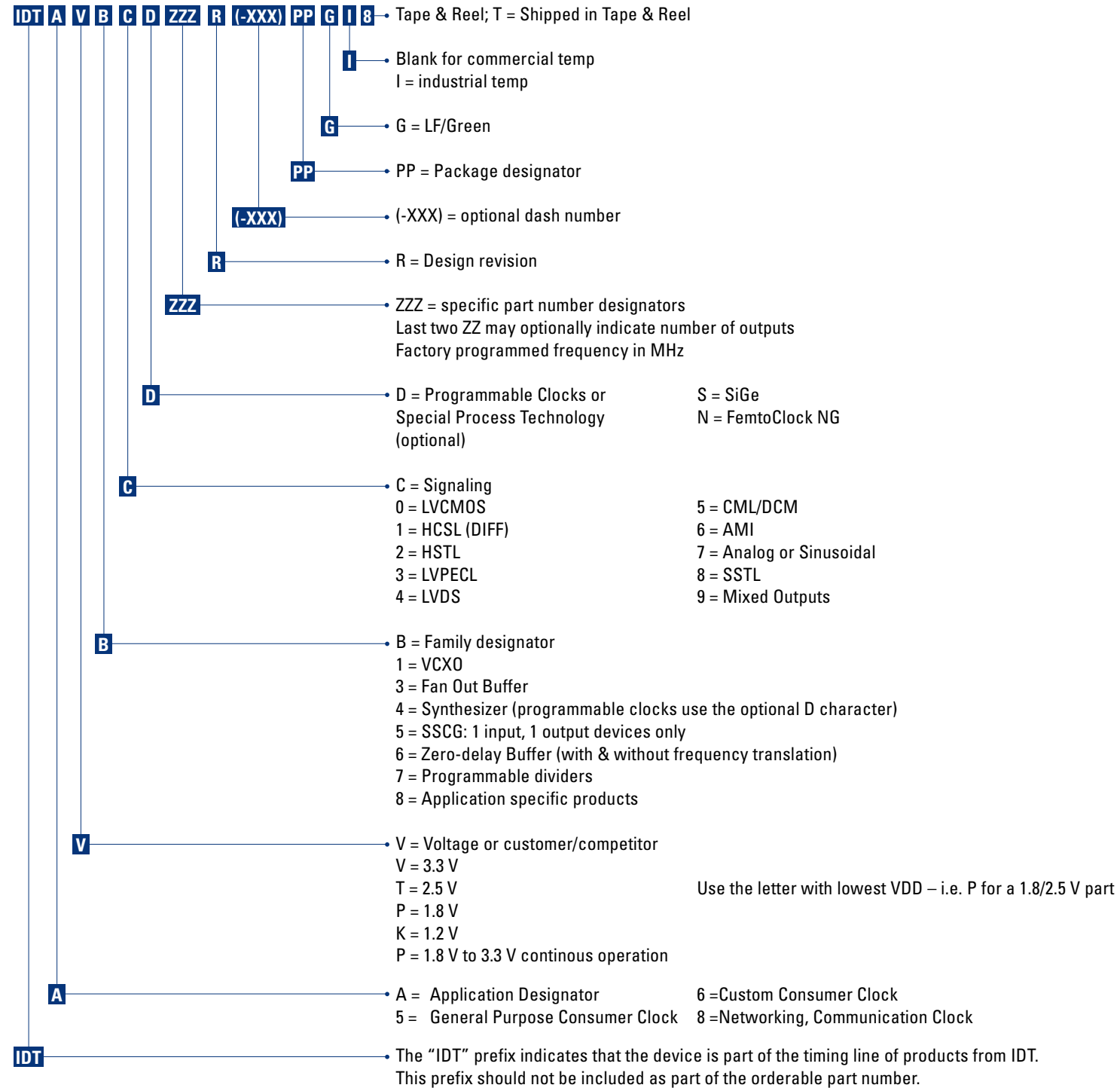

TIMING NOMENCLATURE 2

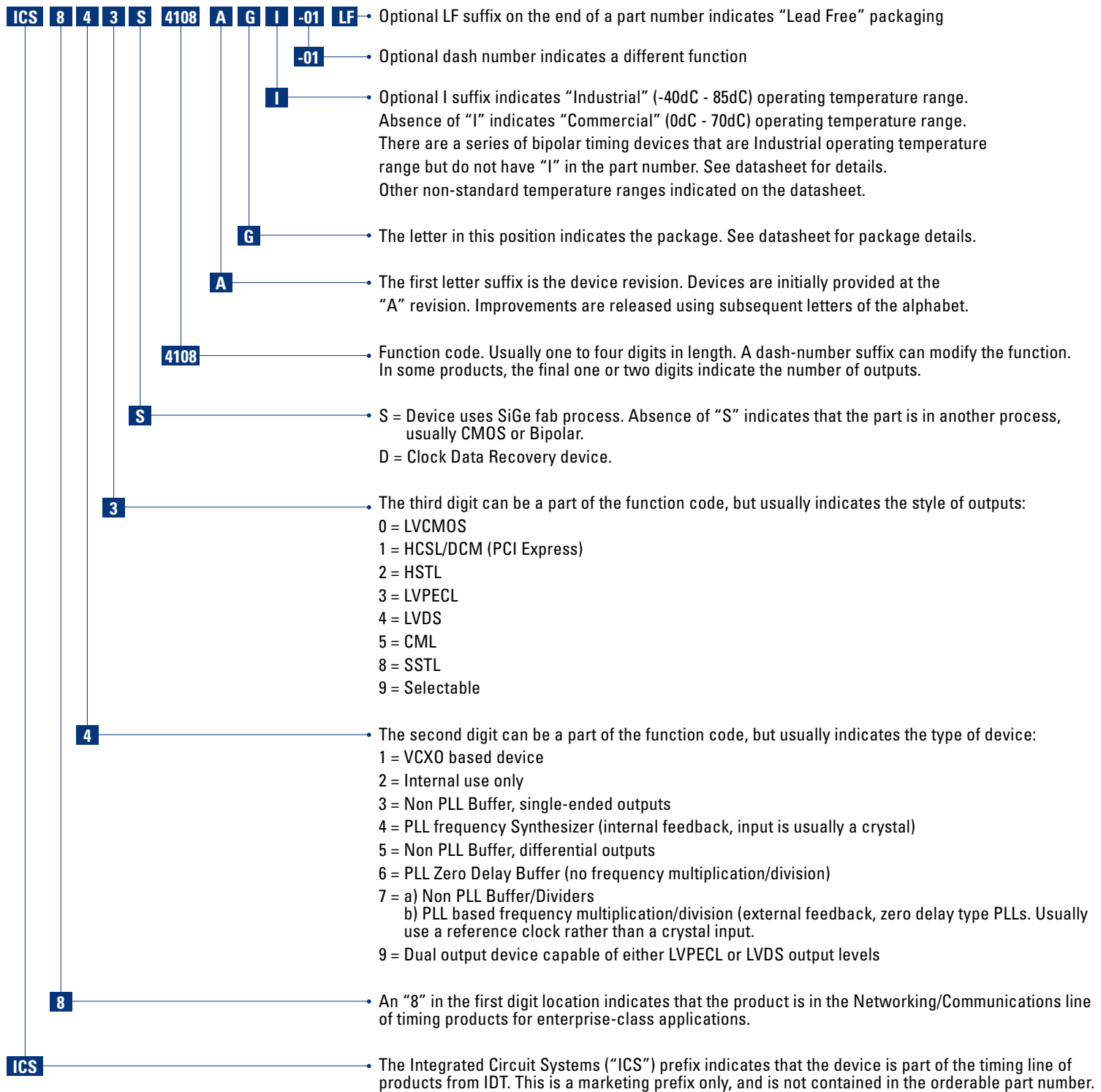

TIMING NOMENCLATURE 3

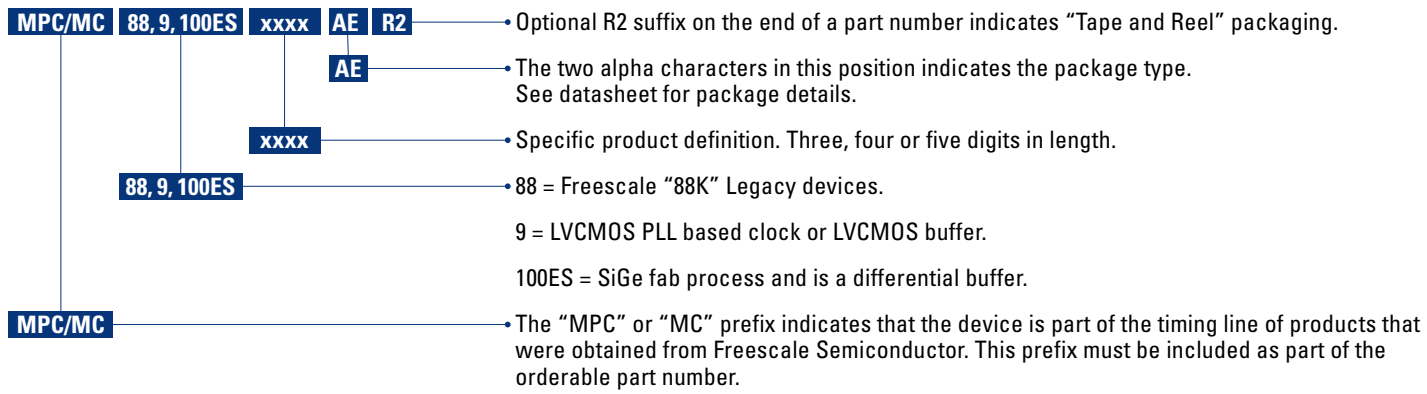

FEMTOCLOCK NG 5x7 CERAMIC

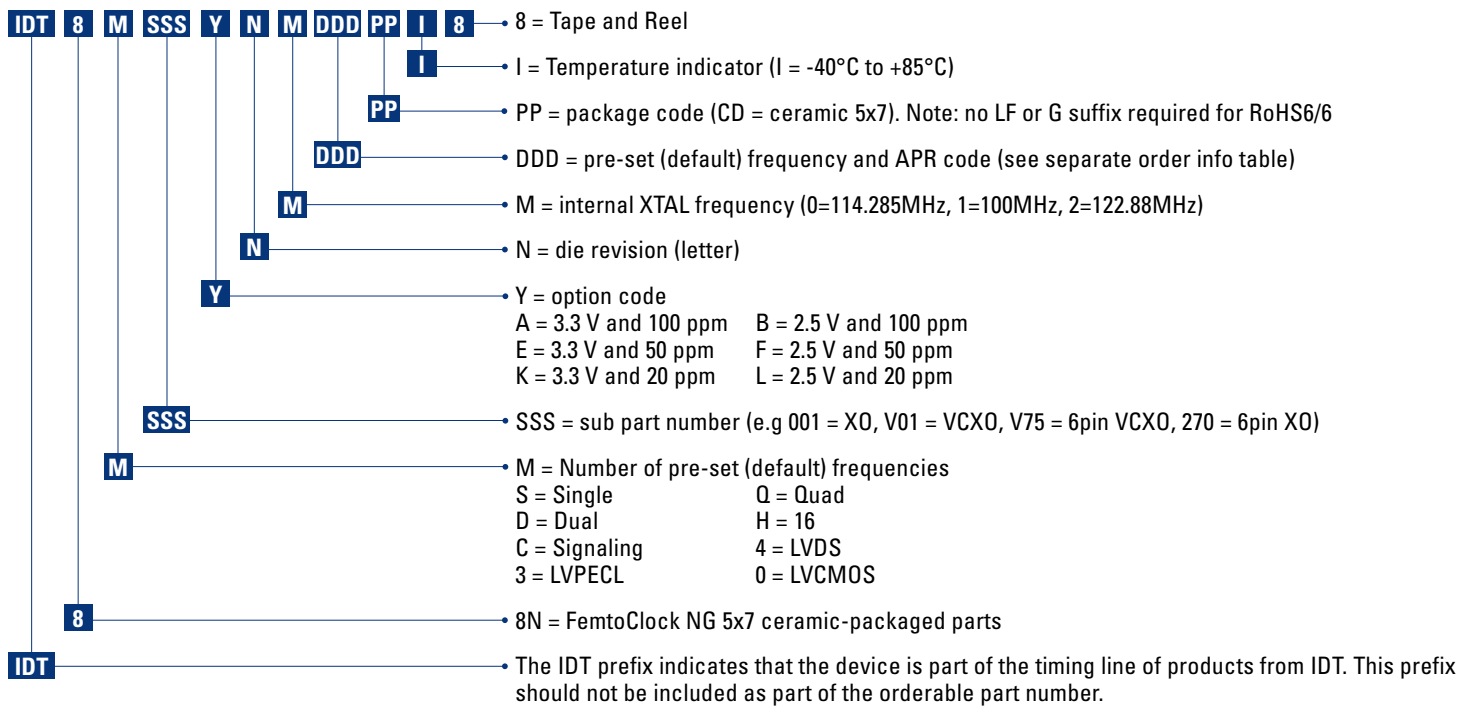

Example: IDT 8N3Q001LG-0001CDI8 is a LVPECL FemtoClockNG programmable oscillator, quad output frequency (125, 100, 122.88, 156.25 MHz), 2.5 V, 20 ppm, G-revision, 114.285 MHz XTAL in a RoHS 6/6 ceramic 5x7 package with tape and reel.

FEMTOCLOCK NG 5x7 10QFN

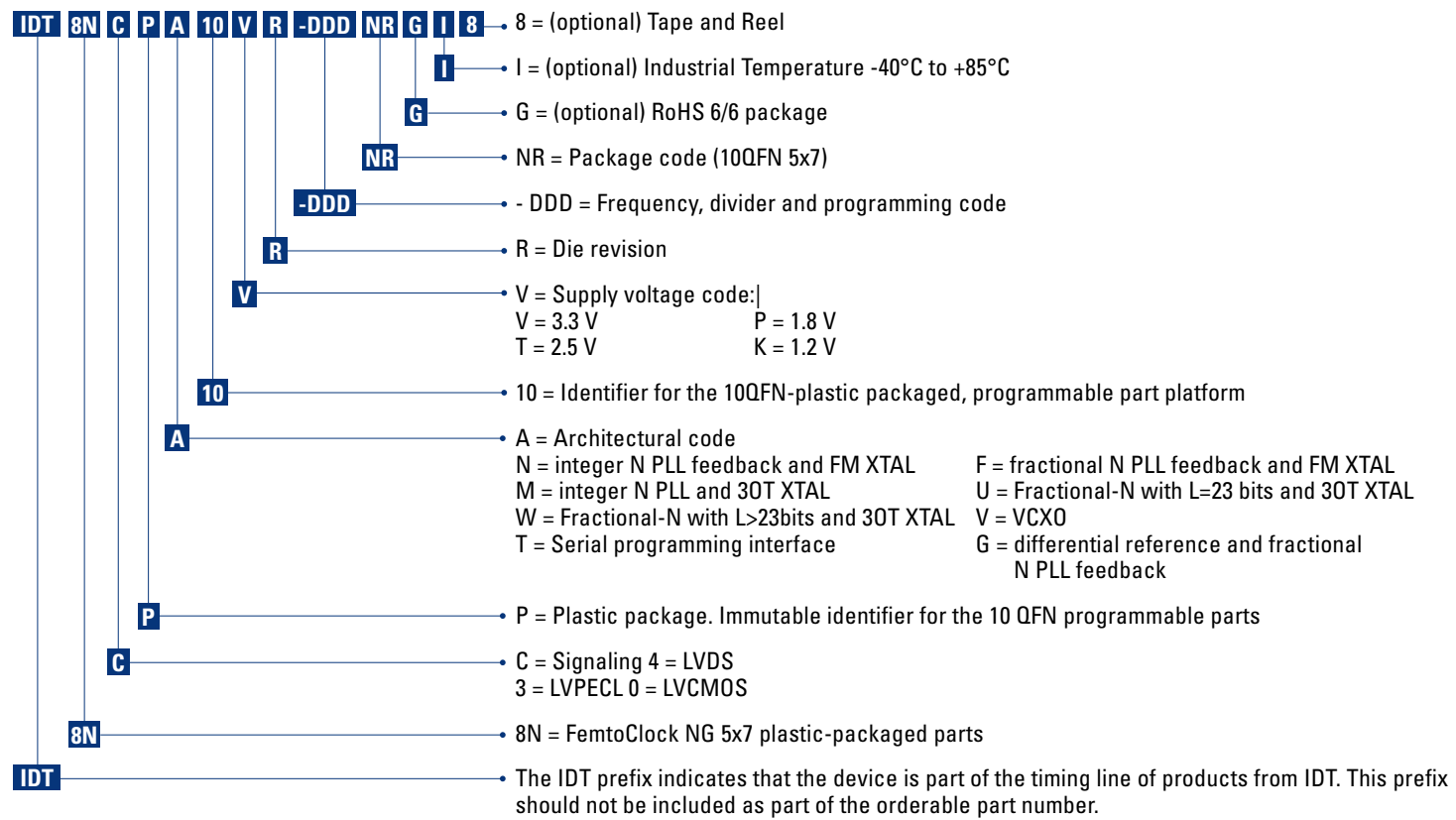

Example: IDT 8N3PN10VA-001NRGI8 is a LVPECL FemtoClockNG programmable clock generator with an internal integer-N feedback PLL, with the frequency coded by "001", 3.3 V, A-revision, in a RoHS 6/6 plastic 5x7 package (10QFN), industrial temperature and with tape and reel.

IDT PC CLOCK NOMENCLATURE

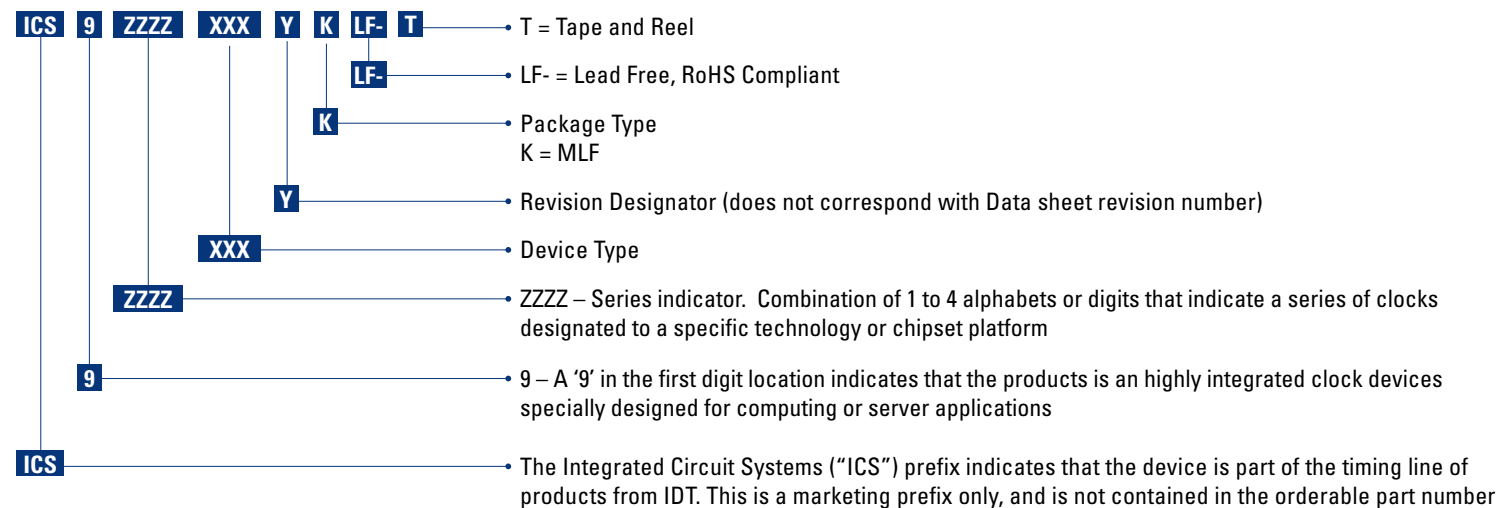

THE LEADER IN TIMING SOLUTIONS.



With a product portfolio that is 10 times greater than the nearest competitor, IDT is in a unique position to address your timing needs.

We are the industry's only one-stop-shop for timing, from fully-featured products like the Universal Frequency Translator, WAN PLL and VersaClock families, through simple clock building-block products like fanout buffers and multiplexers. IDT has a multitude of products that are optimized for specific applications, including several that are featured on the reference designs of silicon-vendor partners.

WORLDWIDE SALES



We utilize a broad spectrum sales channel for the greatest flexibility in getting you the products you need. For a comprehensive list of sales office and Distributors world-wide, please visit our website at : www.idt.com/buy-sample/locations

DISCLAIMER Integrated Device Technology, Inc. (IDT) and its subsidiaries reserve the right to modify the products and/or specifications described herein at any time and at IDT's sole discretion. All information in this document, including descriptions of product features and performance, is subject to change without notice. Performance specifications and the operating parameters of the described products are determined in the independent state and are not guaranteed to perform the same way when installed in customer products. The information contained herein is provided without representation or warranty of any kind, whether express or implied, including, but not limited to, the suitability of IDT's products for any particular purpose, an implied warranty of merchantability, or non-infringement of the intellectual property rights of others. This document is presented only as a guide and does not convey any license under intellectual property rights of IDT or any third parties. IDT's products are not intended for use in life support systems or similar devices where the failure or malfunction of an IDT product can be reasonably expected to significantly affect the health or safety of users. Anyone using an IDT product in such a manner does so at their own risk, absent an express, written agreement by IDT.

Integrated Device Technology, IDT and the IDT logo are registered trademarks of IDT. Other trademarks and service marks used herein, including protected names, logos and designs, are the property of IDT or their respective third party owners. © Copyright 2012. All rights reserved.

X-ON Electronics

Largest Supplier of Electrical and Electronic Components

Click to view similar products for [Clock Generators & Support Products](#) category:

Click to view products by [Renesas](#) manufacturer:

Other Similar products are found below :

[CV183-2TPAG](#) [950810CGLF](#) [9DBV0741AKILF](#) [9VRS4420DKLF](#) [CY25404ZXI226](#) [CY25422SXI-004](#) [MPC9893AE](#) [NB3H5150-01MNTXG](#) [PL602-20-K52TC](#) [ICS557GI-03LF](#) [PI6LC48P0101LIE](#) [82P33814ANLG](#) [840021AGLF](#) [ZL30244LFG7](#) [PI6LC48C21LE](#) [ZL30245LFG7](#) [PI6LC48P0405LIE](#) [PI6LC48P03LE](#) [MAX24505EXG+](#) [ZL30163GDG2](#) [5L1503L-000NVGI8](#) [ZL30673LFG7](#) [MAX24188ETK2](#) [ZL30152GGG2](#) [5L1503-000NVGI8](#) [PI6C557-01BZHIEX](#) [PI6LC48C21LIE](#) [CY2542QC002](#) [5P35023-106NLGI](#) [5X1503L-000NLGI8](#) [ZL30121GGG2V2](#) [ZL30282LDG1](#) [ZL30102QDG1](#) [ZL30159GGG2](#) [DS1070K](#) [ZL30145GGG2](#) [ZL30312GKG2](#) [MAX24405EXG2](#) [ZL30237GGG2](#) [SY100EL34LZG](#) [AD9518-4ABCPZ](#) [MX852BB0030](#) [PI6LC4840ZHE](#) [AD9516-0BCPZ-REEL7](#) [AD9574BCPZ-REEL7](#) [PL602-21TC-R](#) [ZL30105QDG1](#) [ZL30100QDG1](#) [ZL30142GGG2](#) [ZL30250LDG1](#)