

12-OUTPUT DIFFERENTIAL Z-BUFFER FOR PCIe GEN2/3 AND QPI 9ZX21201

General Description

The IDT9ZX21201 is a 12-output DB1200Z suitable for PCI-Express Gen3 or QPI applications. The part is backwards compatible to PCIe Gen1 and Gen2. A fixed external feedback maintains low drift for critical QPI applications. In bypass mode, the IDT9ZX21201 can provide outputs up to 150MHz.

Recommended Application

12-output PCIe Gen3/ QPI differential buffer for Romley and newer platforms

Key Specifications

- Cycle-to-cycle jitter <50ps
- Output-to-output skew < 65 ps
- Input-to-output delay variation <50ps
- PCIe Gen3 phase jitter < 1.0ps RMS
- QPI 9.6GT/s-12UI phase jitter < 0.2ps RMS

Features/Benefits

- Space-saving 64-pin packages
- Fixed feedback path/ 0ps input-to-output delay
- 9 Selectable SMBus Addresses/Multiple devices can share the same SMBus Segment
- 12 OE# pins/Hardware control of each output
- PLL or bypass mode/PLL can dejitter incoming clock
- 100MHz or 133MHz PLL mode operation/supports PCIe and QPI applications
- Selectable PLL bandwidth/minimizes jitter peaking in downstream PLL's
- Spread Spectrum Compatible/tracks spreading input clock for low EMI
- Software control of PLL Bandwidth and Bypass Settings/ PLL can dejitter incoming clock (B Rev only)

Output Features

- 12 - 0.7V differential HCSL output pairs

Functional Block Diagram

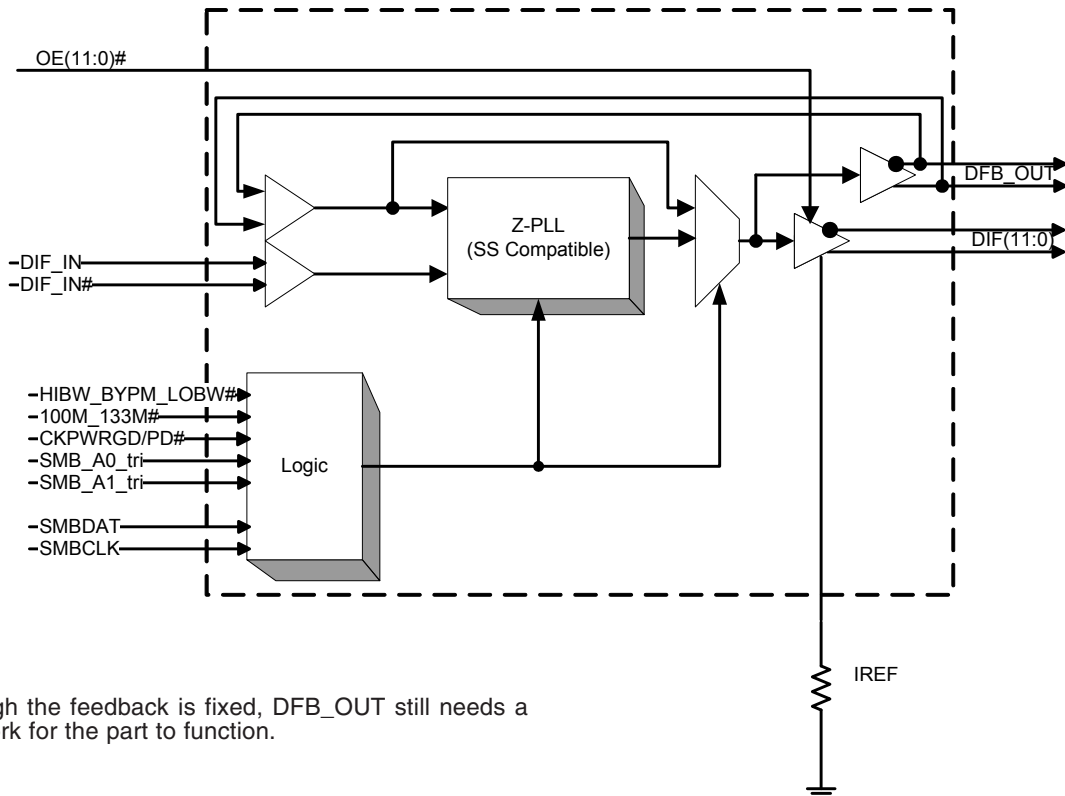

Note: Even though the feedback is fixed, DFB_OUT still needs a termination network for the part to function.

Pin Configuration

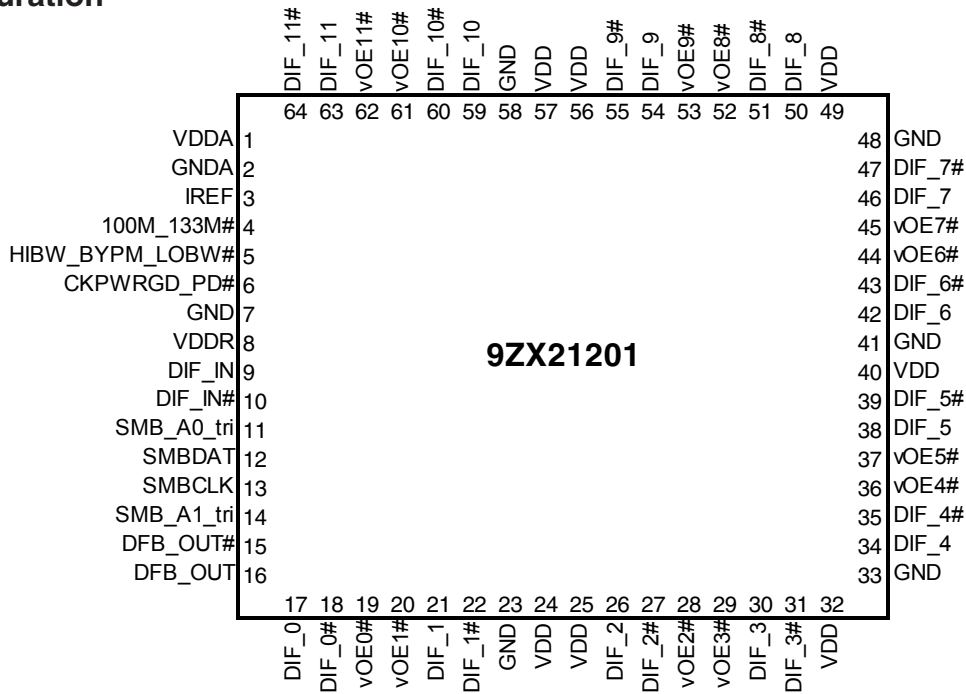

Notes: Pins with ^ prefix have internal ~100K pullup
Pins with v prefix have internal ~100K pulldown.

Tri-level Input Thresholds

Level	Voltage
Low	<0.8V
Mid	1.2<Vin<1.8V
High	Vin > 2.2V

Functionality at Power Up (PLL Mode)

100M_133M#	DIF_IN (MHz)	DIF
1	100.00	DIF_IN
0	133.33	DIF_IN

PLL Operating Mode Readback Table

HiBW_BypM_LoBW#	Byte0, bit 7	Byte 0, bit 6
Low (Low BW)	0	0
Mid (Bypass)	0	1
High (High BW)	1	1

PLL Operating Mode

HiBW_BypM_LoBW#	MODE
Low	PLL Lo BW
Mid	Bypass
High	PLL Hi BW

NOTE: PLL is OFF in Bypass Mode

MLF Power Connections

Pin Number			Description
VDD	VDD	GND	
1		2	Analog PLL
8		7	Analog Input
24,40,57	25,32,49,56	23,33,41,48,58	DIF clocks

9ZX21201 SMBus Addressing

Pin		SMBus Address (Rd/Wrt bit = 0)
SMB_A1_tri	SMB_A0_tri	
0	0	D8
0	M	DA
0	1	DE
M	0	C2
M	M	C4
M	1	C6
1	0	CA
1	M	CC
1	1	CE

Pin Description

PIN #	PIN NAME	TYPE	DESCRIPTION
1	VDDA	PWR	3.3V power for the PLL core.
2	GNDA	PWR	Ground pin for the PLL core.
3	IREF	OUT	This pin establishes the reference for the differential current-mode output pairs. It requires a fixed precision resistor to ground. 475ohm is the standard value for 100ohm differential impedance. Other impedances require different values. See data sheet.
4	100M_133M#	IN	3.3V Input to select operating frequency See Functionality Table for Definition
5	HIBW_BYPM_LOBW#	IN	Trilevel input to select High BW, Bypass or Low BW mode. See PLL Operating Mode Table for Details.
6	CKPWRGD_PD#	IN	Notifies device to sample latched inputs and start up on first high assertion, or exit Power Down Mode on subsequent assertions. Low enters Power Down Mode.
7	GND	PWR	Ground pin.
8	VDDR	PWR	3.3V power for differential input clock (receiver). This VDD should be treated as an analog power rail and filtered appropriately.
9	DIF_IN	IN	0.7 V Differential TRUE input
10	DIF_IN#	IN	0.7 V Differential Complementary Input
11	SMB_A0_tri	IN	SMBus address bit. This is a tri-level input that works in conjunction with the SMB_A1 to decode 1 of 9 SMBus Addresses.
12	SMBDAT	I/O	Data pin of SMBUS circuitry, 5V tolerant
13	SMBCLK	IN	Clock pin of SMBUS circuitry, 5V tolerant
14	SMB_A1_tri	IN	SMBus address bit. This is a tri-level input that works in conjunction with the SMB_A0 to decode 1 of 9 SMBus Addresses.
15	DFB_OUT#	OUT	Complementary half of differential feedback output, provides feedback signal to the PLL for synchronization with input clock to eliminate phase error.
16	DFB_OUT	OUT	True half of differential feedback output, provides feedback signal to the PLL for synchronization with the input clock to eliminate phase error.
17	DIF_0	OUT	0.7V differential true clock output
18	DIF_0#	OUT	0.7V differential Complementary clock output
19	vOE0#	IN	Active low input for enabling DIF pair 0. 1 =disable outputs, 0 = enable outputs
20	vOE1#	IN	Active low input for enabling DIF pair 1. 1 =disable outputs, 0 = enable outputs
21	DIF_1	OUT	0.7V differential true clock output
22	DIF_1#	OUT	0.7V differential Complementary clock output
23	GND	PWR	Ground pin.
24	VDD	PWR	Power supply, nominal 3.3V
25	VDD	PWR	Power supply, nominal 3.3V
26	DIF_2	OUT	0.7V differential true clock output
27	DIF_2#	OUT	0.7V differential Complementary clock output
28	vOE2#	IN	Active low input for enabling DIF pair 2. 1 =disable outputs, 0 = enable outputs
29	vOE3#	IN	Active low input for enabling DIF pair 3. 1 =disable outputs, 0 = enable outputs
30	DIF_3	OUT	0.7V differential true clock output
31	DIF_3#	OUT	0.7V differential Complementary clock output
32	VDD	PWR	Power supply, nominal 3.3V

Pin Description (continued)

33	GND	PWR	Ground pin.
34	DIF_4	OUT	0.7V differential true clock output
35	DIF_4#	OUT	0.7V differential Complementary clock output
36	vOE4#	IN	Active low input for enabling DIF pair 4 1 =disable outputs, 0 = enable outputs
37	vOE5#	IN	Active low input for enabling DIF pair 5. This pin has an internal pull-down 1 =disable outputs, 0 = enable outputs
38	DIF_5	OUT	0.7V differential true clock output
39	DIF_5#	OUT	0.7V differential Complementary clock output
40	VDD	PWR	Power supply, nominal 3.3V
41	GND	PWR	Ground pin.
42	DIF_6	OUT	0.7V differential true clock output
43	DIF_6#	OUT	0.7V differential Complementary clock output
44	vOE6#	IN	Active low input for enabling DIF pair 6. This pin has an internal pull-down 1 =disable outputs, 0 = enable outputs
45	vOE7#	IN	Active low input for enabling DIF pair 7. This pin has an internal pull-down 1 =disable outputs, 0 = enable outputs
46	DIF_7	OUT	0.7V differential true clock output
47	DIF_7#	OUT	0.7V differential Complementary clock output
48	GND	PWR	Ground pin.
49	VDD	PWR	Power supply, nominal 3.3V
50	DIF_8	OUT	0.7V differential true clock output
51	DIF_8#	OUT	0.7V differential Complementary clock output
52	vOE8#	IN	Active low input for enabling DIF pair 8. This pin has an internal pull-down 1 =disable outputs, 0 = enable outputs
53	vOE9#	IN	Active low input for enabling DIF pair 9. This pin has an internal pull-down 1 =disable outputs, 0 = enable outputs
54	DIF_9	OUT	0.7V differential true clock output
55	DIF_9#	OUT	0.7V differential Complementary clock output
56	VDD	PWR	Power supply, nominal 3.3V
57	VDD	PWR	Power supply, nominal 3.3V
58	GND	PWR	Ground pin.
59	DIF_10	OUT	0.7V differential true clock output
60	DIF_10#	OUT	0.7V differential Complementary clock output
61	vOE10#	IN	Active low input for enabling DIF pair 10. This pin has an internal pull-down 1 =disable outputs, 0 = enable outputs
62	vOE11#	IN	Active low input for enabling DIF pair 11. This pin has an internal pull-down 1 =disable outputs, 0 = enable outputs
63	DIF_11	OUT	0.7V differential true clock output
64	DIF_11#	OUT	0.7V differential Complementary clock output

Electrical Characteristics - Absolute Maximum Ratings

PARAMETER	SYMBOL	CONDITIONS	MIN	TYP	MAX	UNITS	NOTES
3.3V Core Supply Voltage	VDD, VDDA	VDD for core logic and PLL			4.6	V	1,2
Input Low Voltage	V _{IL}		GND-0.5			V	1
Input High Voltage	V _{IH}	Except for SMBus interface			V _{DD} +0.5V	V	1
Input High Voltage	V _{IHSMB}	SMBus clock and data pins			5.5V	V	1
Storage Temperature	T _s		-65		150	°C	1
Junction Temperature	T _j				125	°C	1
Input ESD protection	ESD prot	Human Body Model	2000			V	1

¹Guaranteed by design and characterization, not 100% tested in production.

²Operation under these conditions is neither implied nor guaranteed.

Electrical Characteristics - Input/Supply/Common Parameters

T_A = T_{COM}; Supply Voltage V_{DD}/V_{DDA} = 3.3 V +/-5%

PARAMETER	SYMBOL	CONDITIONS	MIN	TYP	MAX	UNITS	NOTES
Ambient Operating Temperature	T _{COM}	Commercial range	0		70	°C	1
Input High Voltage	V _{IH}	Single-ended inputs, except SMBus, low threshold and tri-level inputs	2		V _{DD} + 0.3	V	1
Input Low Voltage	V _{IL}	Single-ended inputs, except SMBus, low threshold and tri-level inputs	GND - 0.3		0.8	V	1
Input Current	I _{IN}	Single-ended inputs, V _{IN} = GND, V _{IN} = VDD	-5		5	uA	1
	I _{INP}	Single-ended inputs V _{IN} = 0 V; Inputs with internal pull-up resistors V _{IN} = VDD; Inputs with internal pull-down resistors	-200		200	uA	1
Input Frequency	F _{IBYP}	V _{DD} = 3.3 V, Bypass mode	33		150	MHz	2
	F _{IPLL}	V _{DD} = 3.3 V, 100MHz PLL mode	90	100.00	110	MHz	2
	F _{IPLL}	V _{DD} = 3.3 V, 133.33MHz PLL mode	120	133.33	147	MHz	2
Pin Inductance	L _{pin}				7	nH	1
Capacitance	C _{IN}	Logic Inputs, except DIF_IN	1.5		5	pF	1
	C _{INDIF_IN}	DIF_IN differential clock inputs	1.5		2.7	pF	1,4
	C _{OUT}	Output pin capacitance			6	pF	1
Clk Stabilization	T _{STAB}	From V _{DD} Power-Up and after input clock stabilization or de-assertion of PD# to 1st clock		0.300	1	ms	1,2
Input SS Modulation Frequency	f _{MODIN}	Allowable Frequency (Triangular Modulation)	30		33	kHz	1
OE# Latency	t _{LATOE#}	DIF start after OE# assertion DIF stop after OE# deassertion	4	6	12	clocks	1
Tdrive_PD#	t _{DRVPD}	DIF output enable after PD# de-assertion		16	300	us	1,3
Tfall	t _F	Fall time of control inputs			10	ns	1,2
Trise	t _R	Rise time of control inputs			10	ns	1,2
SMBus Input Low Voltage	V _{ILSMB}				0.8	V	1
SMBus Input High Voltage	V _{IHSMB}		2.1		V _{DD} SMB	V	1
SMBus Output Low Voltage	V _{OLSMB}	@ I _{PULLUP}			0.4	V	1
SMBus Sink Current	I _{PULLUP}	@ V _{OL}	4			mA	1
Nominal Bus Voltage	V _{DD} SMB	3V to 5V +/- 10%	2.7		5.5	V	1
SCLK/SDATA Rise Time	t _{RSMB}	(Max V _{IL} - 0.15) to (Min V _{IH} + 0.15)			1000	ns	1
SCLK/SDATA Fall Time	t _{FSMB}	(Min V _{IH} + 0.15) to (Max V _{IL} - 0.15)			300	ns	1
SMBus Operating Frequency	f _{MAXSMB}	Maximum SMBus operating frequency			100	kHz	1,5

¹Guaranteed by design and characterization, not 100% tested in production.

²Control input must be monotonic from 20% to 80% of input swing.

³Time from deassertion until outputs are >200 mV

⁴DIF_IN input

⁵The differential input clock must be running for the SMBus to be active

Electrical Characteristics - DIF_IN Clock Input Parameters

T_{AMB}=T_{COM} unless otherwise indicated, Supply Voltages per normal operation conditions, See Test Loads for Loading Conditions

PARAMETER	SYMBOL	CONDITIONS	MIN	TYP	MAX	UNITS	NOTES
Input Crossover Voltage - DIF_IN	V _{CROSS}	Cross Over Voltage	150		900	mV	1
Input Swing - DIF_IN	V _{SWING}	Differential value	300			mV	1
Input Slew Rate - DIF_IN	dv/dt	Measured differentially	0.4		8	V/ns	1,2
Input Leakage Current	I _{IN}	V _{IN} = V _{DD} , V _{IN} = GND	-5		5	uA	
Input Duty Cycle	d _{in}	Measurement from differential waveform	45		55	%	1
Input Jitter - Cycle to Cycle	J _{DIFin}	Differential Measurement	0		125	ps	1

¹ Guaranteed by design and characterization, not 100% tested in production.

² Slew rate measured through +/-75mV window centered around differential zero

Electrical Characteristics - DIF 0.7V Current Mode Differential Outputs

T_A = T_{COM}; Supply Voltage V_{DD}/V_{DDA} = 3.3 V +/-5%

PARAMETER	SYMBOL	CONDITIONS	MIN	TYP	MAX	UNITS	NOTES
Slew rate	Trf	Scope averaging on	1	2	4	V/ns	1, 2, 3
Slew rate matching	ΔTrf	Slew rate matching, Scope averaging on		8	20	%	1, 2, 4
Voltage High	VHigh	Statistical measurement on single-ended signal using oscilloscope math function. (Scope averaging on)	660	705	850	mV	1
Voltage Low	VLow		-150	1	150		1
Max Voltage	Vmax	Measurement on single ended signal using absolute value. (Scope averaging off)		725	1150	mV	1
Min Voltage	Vmin		-300	-22			1
Vswing	Vswing	Scope averaging off	300	1407		mV	1, 2
Crossing Voltage (abs)	Vcross_abs	Scope averaging off	250	309	550	mV	1, 5
Crossing Voltage (var)	ΔVcross	Scope averaging off		22	140	mV	1, 6

¹ Guaranteed by design and characterization, not 100% tested in production. I_{REF} = V_{DD}/(3xR_R). For R_R = 412Ω (1%), I_{REF} = 2.7mA.

I_{OH} = 6.4 x I_{REF} and V_{OH} = 0.7V @ Z_O=85Ω differential impedance.

² Measured from differential waveform

³ Slew rate is measured through the Vswing voltage range centered around differential 0V. This results in a +/-150mV window around differential 0V.

⁴ Matching applies to rising edge rate of Clock / falling edge rate of Clock#. It is measured in a +/-75mV window centered on the average cross point where Clock rising meets Clock# falling. The median cross point is used to calculate the voltage thresholds the oscilloscope uses for the edge rate calculations.

⁵ Vcross is defined as voltage where Clock = Clock# measured on a component test board and only applies to the differential rising edge (i.e. Clock rising and Clock# falling).

⁶ The total variation of all Vcross measurements in any particular system. Note that this is a subset of V_{cross_min}/max (V_{cross} absolute) allowed. The intent is to limit Vcross induced modulation by setting V_{cross_delta} to be smaller than V_{cross} absolute.

Electrical Characteristics - Current Consumption

T_A = T_{COM}; Supply Voltage V_{DD}/V_{DDA} = 3.3 V +/-5%

PARAMETER	SYMBOL	CONDITIONS	MIN	TYP	MAX	UNITS	NOTES
Operating Current	I _{DDVDD}	133MHz, C _L = Full load; VDD rail, Z _O =85Ω		260	275	mA	1
	I _{DDVDDA}	133MHz, C _L = Full load; VDD rail, Z _O =85Ω		13	20	mA	1
Powerdown Current	I _{DDVDDPD}	Power Down, VDD rail, Z _O =85Ω		2	6	mA	1
	I _{DDVDDAPD}	Power Down, VDD rail, Z _O =85Ω		1.3	2	mA	1

¹ Guaranteed by design and characterization, not 100% tested in production.

Electrical Characteristics - Skew and Differential Jitter ParametersT_A = T_{COMI}; Supply Voltage V_{DD}/V_{DDA} = 3.3 V +/-5%

PARAMETER	SYMBOL	CONDITIONS	MIN	TYP	MAX	UNITS	NOTES
CLK_IN, DIF[x:0]	t _{SPO_PLL}	Input-to-Output Skew in PLL mode nominal value @ 25°C, 3.3V	-100	29	100	ps	1,2,4,5,8
CLK_IN, DIF[x:0]	t _{PD_BYP}	Input-to-Output Skew in Bypass mode nominal value @ 25°C, 3.3V	2.5	3.7	4.5	ns	1,2,3,5,8
CLK_IN, DIF[x:0]	t _{DSPO_PLL}	Input-to-Output Skew Variation in PLL mode across voltage and temperature	-50		50	ps	1,2,3,5,8
CLK_IN, DIF[x:0]	t _{DSPO_BYP}	Input-to-Output Skew Variation in Bypass mode across voltage and temperature	-250		250	ps	1,2,3,5,8
CLK_IN, DIF[x:0]	t _{DTE}	Random Differential Tracking error between two 9ZX devices in Hi BW Mode		2.9	5	ps (rms)	1,2,3,5,8
CLK_IN, DIF[x:0]	t _{DSSTE}	Random Differential Spread Spectrum Tracking error between two 9ZX devices in Hi BW Mode		14	75	ps	1,2,3,5,8
DIF[x:0]	t _{SKREW_ALL}	Output-to-Output Skew across all outputs (Common to Bypass and PLL mode)		32	65	ps	1,2,3,8
PLL Jitter Peaking	j _{peak-hibw}	LOBW#_BYPASS_HIBW = 1	0	1.8	2.5	dB	7,8
PLL Jitter Peaking	j _{peak-lobw}	LOBW#_BYPASS_HIBW = 0	0	0.7	2	dB	7,8
PLL Bandwidth	pll _{HIBW}	LOBW#_BYPASS_HIBW = 1	2	3.1	4	MHz	8,9
PLL Bandwidth	pll _{LOBW}	LOBW#_BYPASS_HIBW = 0	0.7	1.1	1.4	MHz	8,9
Duty Cycle	t _{DC}	Measured differentially, PLL Mode	45	49.6	55	%	1
Duty Cycle Distortion	t _{DCD}	Measured differentially, Bypass Mode @100MHz	-2	-0.2	2	%	1,10
Jitter, Cycle to cycle	t _{jcy-cyc}	PLL mode		15.7	50	ps	1,11
		Additive Jitter in Bypass Mode		0.1	50	ps	1,11

Notes for preceding table:

- ¹ Measured into fixed 2 pF load cap. Input to output skew is measured at the first output edge following the corresponding input.
- ² Measured from differential cross-point to differential cross-point. This parameter can be tuned with external feedback path, if present.
- ³ All Bypass Mode Input-to-Output specs refer to the timing between an input edge and the specific output edge created by it.
- ⁴ This parameter is deterministic for a given device
- ⁵ Measured with scope averaging on to find mean value.
- ⁶ t is the period of the input clock
- ⁷ Measured as maximum pass band gain. At frequencies within the loop BW, highest point of magnification is called PLL jitter peaking.
- ⁸ Guaranteed by design and characterization, not 100% tested in production.
- ⁹ Measured at 3 db down or half power point.
- ¹⁰ Duty cycle distortion is the difference in duty cycle between the output and the input clock when the device is operated in bypass mode.
- ¹¹ Measured from differential waveform

Electrical Characteristics - Phase Jitter Parameters

T_A = T_{COM}; Supply Voltage V_{DD}/V_{DDA} = 3.3 V +/-5%

PARAMETER	SYMBOL	CONDITIONS	MIN	TYP	MAX	UNITS	Notes
Phase Jitter, PLL Mode	t _{phPCIeG1}	PCIe Gen 1		32	86	ps (p-p)	1,2,3
	t _{phPCIeG2}	PCIe Gen 2 Lo Band 10kHz < f < 1.5MHz		0.8	3	ps (rms)	1,2
		PCIe Gen 2 High Band 1.5MHz < f < Nyquist (50MHz)		1.9	3.1	ps (rms)	1,2
	t _{phPCIeG3}	PCIe Gen 3 (PLL BW of 2-4MHz, CDR = 10MHz)		0.45	1	ps (rms)	1,2,4
	t _{phQPI_SMI}	QPI & SMI (100MHz or 133MHz, 4.8Gb/s, 6.4Gb/s 12UI)		0.20	0.5	ps (rms)	1,5
		QPI & SMI (100MHz, 8.0Gb/s, 12UI)		0.14	0.3	ps (rms)	1,5
QPI & SMI (100MHz, 9.6Gb/s, 12UI)			0.12	0.2	ps (rms)	1,5	
Additive Phase Jitter, Bypass mode	t _{phPCIeG1}	PCIe Gen 1		0.10	10	ps (p-p)	1,2,3
	t _{phPCIeG2}	PCIe Gen 2 Lo Band 10kHz < f < 1.5MHz		0.13	0.3	ps (rms)	1,2,6
		PCIe Gen 2 High Band 1.5MHz < f < Nyquist (50MHz)		0.10	0.7	ps (rms)	1,2,6
	t _{phPCIeG3}	PCIe Gen 3 (PLL BW of 2-4MHz, CDR = 10MHz)		0.10	0.3	ps (rms)	1,2,4,6
	t _{phQPI_SMI}	QPI & SMI (100MHz or 133MHz, 4.8Gb/s, 6.4Gb/s 12UI)		0.09	0.3	ps (rms)	1,5,6
		QPI & SMI (100MHz, 8.0Gb/s, 12UI)		0.09	0.1	ps (rms)	1,5,6
QPI & SMI (100MHz, 9.6Gb/s, 12UI)			0.09	0.1	ps (rms)	1,5,6	

¹ Applies to all outputs.

² See <http://www.pcisig.com> for complete specs

³ Sample size of at least 100K cycles. This figures extrapolates to 108ps pk-pk @ 1M cycles for a BER of 1-12.

⁴ Subject to final radification by PCI SIG.

⁵ Calculated from Intel-supplied Clock Jitter Tool v 1.6.4

⁶ For RMS figures, additive jitter is calculated by solving the following equation: (Additive jitter)² = (total jitter)² - (input jitter)²

Power Management Table

Inputs		Control Bits/Pins			Outputs	PLL State
CKPWRGD•/PD#	DIF_IN/ DIF_IN#	SMBus EN bit	OE# Pin	DIF(11:0)/ DIF(11:0)#	DFB_OUT/ DFB_OUT#	
0	X	X	X	Hi-Z ¹	Hi-Z ¹	OFF
1	Running	0	X	Hi-Z ¹	Running	ON
		1	0	Running	Running	ON
		1	1	Hi-Z ¹	Running	ON

NOTE:

1. Due to external pull down resistors, HI-Z results in Low/Low on the True/Complement outputs

Clock Periods - Differential Outputs with Spread Spectrum Disabled

SSC OFF	Center Freq. MHz	Measurement Window							Units	Notes
		1 Clock	1us	0.1s	0.1s	0.1s	1us	1 Clock		
		-c2c jitter AbsPer Min	-SSC Short-Term Average Min	- ppm Long-Term Average Min	0 ppm Period Nominal	+ ppm Long-Term Average Max	+SSC Short-Term Average Max	+c2c jitter AbsPer Max		
DIF	100.00	9.94900		9.99900	10.00000	10.00100		10.05100	ns	1,2,3
	133.33	7.44925		7.49925	7.50000	7.50075		7.55075	ns	1,2,4

Clock Periods - Differential Outputs with Spread Spectrum Enabled

SSC ON	Center Freq. MHz	Measurement Window							Units	Notes
		1 Clock	1us	0.1s	0.1s	0.1s	1us	1 Clock		
		-c2c jitter AbsPer Min	-SSC Short-Term Average Min	- ppm Long-Term Average Min	0 ppm Period Nominal	+ ppm Long-Term Average Max	+SSC Short-Term Average Max	+c2c jitter AbsPer Max		
DIF	99.75	9.94906	9.99906	10.02406	10.02506	10.02607	10.05107	10.10107	ns	1,2,3
	133.00	7.44930	7.49930	7.51805	7.51880	7.51955	7.53830	7.58830	ns	1,2,4

Notes:

- ¹Guaranteed by design and characterization, not 100% tested in production.
- ²All Long Term Accuracy specifications are guaranteed with the assumption that the input clock complies with CK420BQ/CK410B+ accuracy requirements (+/-100ppm). The 9ZX21201 itself does not contribute to ppm error.
- ³ Driven by SRC output of main clock, 100 MHz PLL Mode or Bypass mode
- ⁴ Driven by CPU output of main clock, 133 MHz PLL Mode or Bypass mode

Differential Output Termination Table

DIF Zo (Ω)	Iref (Ω)	Rs (Ω)	Rp (Ω)
100	475	33	50
85	412	27	42.2 or 43.2

9ZX21201 Differential Test Loads

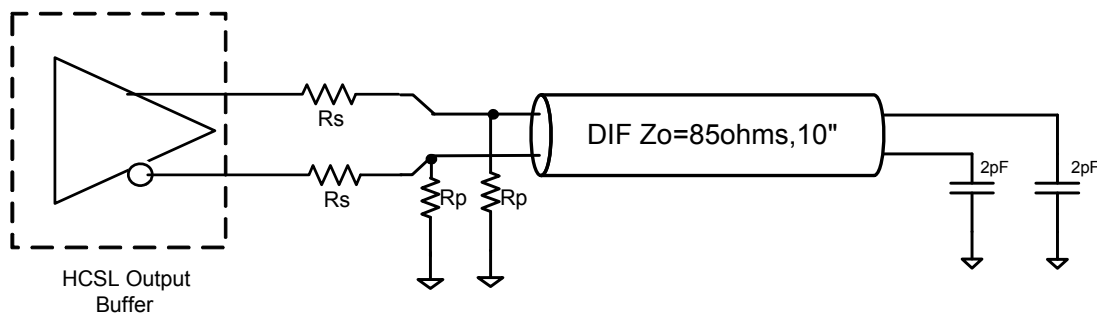

General SMBus serial interface information for the 9ZX21201

How to Write:

- Controller (host) sends a start bit.
- Controller (host) sends the write address $XX_{(H)}$
- IDT clock will **acknowledge**
- Controller (host) sends the beginning byte location = N
- IDT clock will **acknowledge**
- Controller (host) sends the data byte count = X
- IDT clock will **acknowledge**
- Controller (host) starts sending **Byte N through Byte N + X - 1**
- IDT clock will **acknowledge** each byte **one at a time**
- Controller (host) sends a Stop bit

How to Read:

- Controller (host) will send start bit.
- Controller (host) sends the write address $XX_{(H)}$
- IDT clock will **acknowledge**
- Controller (host) sends the beginning byte location = N
- IDT clock will **acknowledge**
- Controller (host) will send a separate start bit.
- Controller (host) sends the read address $YY_{(H)}$
- IDT clock will **acknowledge**
- IDT clock will send the data byte count = X
- IDT clock sends **Byte N + X - 1**
- IDT clock sends **Byte 0 through byte X (if $X_{(H)}$ was written to byte 8).**
- Controller (host) will need to acknowledge each byte
- Controller (host) will send a not acknowledge bit
- Controller (host) will send a stop bit

Index Block Write Operation		
Controller (Host)		IDT (Slave/Receiver)
T	starT bit	
Slave Address $XX_{(H)}$		
WR	WRite	
		ACK
Beginning Byte = N		
		ACK
Data Byte Count = X		
		ACK
Beginning Byte N	X Byte	ACK
◇		◇
◇		◇
◇		◇
Byte N + X - 1		ACK
P	stoP bit	

Note: $XX_{(H)}$ is defined by SMBus address select pins.

Index Block Read Operation		
Controller (Host)		IDT (Slave/Receiver)
T	starT bit	
Slave Address $XX_{(H)}$		
WR	WRite	
		ACK
Beginning Byte = N		
		ACK
RT	Repeat starT	
Slave Address $YY_{(H)}$		
RD	ReaD	
		ACK
		Data Byte Count = X
ACK		
		Beginning Byte N
ACK		
◇		◇
◇		◇
◇		◇
		Byte N + X - 1
N	Not acknowledge	
P	stoP bit	

SMBusTable: PLL Mode, and Frequency Select Register

Byte 0	Pin #	Name	Control Function	Type	0	1	Default
Bit 7	5	PLL Mode 1	PLL Operating Mode Rd back 1	R	See PLL Operating Mode Readback Table		Latch
Bit 6	5	PLL Mode 0	PLL Operating Mode Rd back 0	R			Latch
Bit 5			Reserved				0
Bit 4			Reserved				0
Bit 3	These bits available in B rev only.	PLL_SW_EN	Enable S/W control of PLL BW	RW	HW Latch	S/W Control	0
Bit 2		PLL Mode 1	PLL Operating Mode 1	RW	See PLL Operating Mode Readback Table		1
Bit 1		PLL Mode 0	PLL Operating Mode 1	RW			1
Bit 0	4	100M 133M#	Frequency Select Readback	R	133MHz	100MHz	Latch

SMBusTable: Output Control Register

Byte 1	Pin #	Name	Control Function	Type	0	1	Default
Bit 7	47/46	DIF 7 En	Output Control - '0' overrides OE# pin	RW	Low/Low	Enable	1
Bit 6	43/42	DIF 6 En	Output Control - '0' overrides OE# pin	RW			1
Bit 5	39/38	DIF 5 En	Output Control - '0' overrides OE# pin	RW			1
Bit 4	35/34	DIF 4 En	Output Control - '0' overrides OE# pin	RW			1
Bit 3	30/31	DIF 3 En	Output Control - '0' overrides OE# pin	RW			1
Bit 2	26/27	DIF 2 En	Output Control - '0' overrides OE# pin	RW			1
Bit 1	21/22	DIF 1 En	Output Control - '0' overrides OE# pin	RW			1
Bit 0	17/18	DIF 0 En	Output Control - '0' overrides OE# pin	RW			1

SMBusTable: Output Control Register

Byte 2	Pin #	Name	Control Function	Type	0	1	Default
Bit 7			Reserved				0
Bit 6			Reserved				0
Bit 5			Reserved				0
Bit 4			Reserved				0
Bit 3	64/63	DIF 11 En	Output Control - '0' overrides OE# pin	RW	Low/Low	Enable	1
Bit 2	59/60	DIF 10 En	Output Control - '0' overrides OE# pin	RW			1
Bit 1	54/55	DIF 9 En	Output Control - '0' overrides OE# pin	RW			1
Bit 0	50/51	DIF 8 En	Output Control - '0' overrides OE# pin	RW			1

SMBusTable: Reserved Register

Byte 3	Pin #	Name	Control Function	Type	0	1	Default
Bit 7			Reserved				0
Bit 6			Reserved				0
Bit 5			Reserved				0
Bit 4			Reserved				0
Bit 3			Reserved				0
Bit 2			Reserved				0
Bit 1			Reserved				0
Bit 0			Reserved				0

SMBusTable: Reserved Register

Byte 4	Pin #	Name	Control Function	Type	0	1	Default
Bit 7			Reserved				0
Bit 6			Reserved				0
Bit 5			Reserved				0
Bit 4			Reserved				0
Bit 3			Reserved				0
Bit 2			Reserved				0
Bit 1			Reserved				0
Bit 0			Reserved				0

SMBusTable: Vendor & Revision ID Register

Byte 5	Pin #	Name	Control Function	Type	0	1	Default
Bit 7	-	RID3	REVISION ID	R	A rev = 0000 B rev = 0001		X
Bit 6	-	RID2		R			X
Bit 5	-	RID1		R			X
Bit 4	-	RID0		R			X
Bit 3	-	VID3	VENDOR ID	R	0001 for IDT/ICS		0
Bit 2	-	VID2		R			0
Bit 1	-	VID1		R			0
Bit 0	-	VID0		R			1

SMBusTable: DEVICE ID

Byte 6	Pin #	Name	Control Function	Type	0	1	Default
Bit 7	-		Device ID 7 (MSB)	R	1201 is 201 decimal or C9 hex		1
Bit 6	-		Device ID 6	R			1
Bit 5	-		Device ID 5	R			0
Bit 4	-		Device ID 4	R			0
Bit 3	-		Device ID 3	R			1
Bit 2	-		Device ID 2	R			0
Bit 1	-		Device ID 1	R			0
Bit 0	-		Device ID 0	R			1

SMBusTable: Byte Count Register

Byte 7	Pin #	Name	Control Function	Type	0	1	Default
Bit 7			Reserved				0
Bit 6			Reserved				0
Bit 5			Reserved				0
Bit 4	-	BC4	Writing to this register configures how many bytes will be read back.	RW	Default value is 8 hex, so 9 bytes (0 to 8) will be read back by default.		0
Bit 3	-	BC3		RW			1
Bit 2	-	BC2		RW			0
Bit 1	-	BC1		RW			0
Bit 0	-	BC0		RW			0

SMBusTable: Reserved Register

Byte 8	Pin #	Name	Control Function	Type	0	1	Default
Bit 7			Reserved				0
Bit 6			Reserved				0
Bit 5			Reserved				0
Bit 4			Reserved				0
Bit 3			Reserved				0
Bit 2			Reserved				0
Bit 1			Reserved				0
Bit 0			Reserved				0

DIF Reference Clock			
Common Recommendations for Differential Routing	Dimension or Value	Unit	Figure
L1 length, route as non-coupled 50ohm trace	0.5 max	inch	1
L2 length, route as non-coupled 50ohm trace	0.2 max	inch	1
L3 length, route as non-coupled 50ohm trace	0.2 max	inch	1
R_s	33	ohm	1
R_t	49.9	ohm	1

Down Device Differential Routing			
L4 length, route as coupled microstrip 100ohm differential trace	2 min to 16 max	inch	1
L4 length, route as coupled stripline 100ohm differential trace	1.8 min to 14.4 max	inch	1

Differential Routing to PCI Express Connector			
L4 length, route as coupled microstrip 100ohm differential trace	0.25 to 14 max	inch	2
L4 length, route as coupled stripline 100ohm differential trace	0.225 min to 12.6 max	inch	2

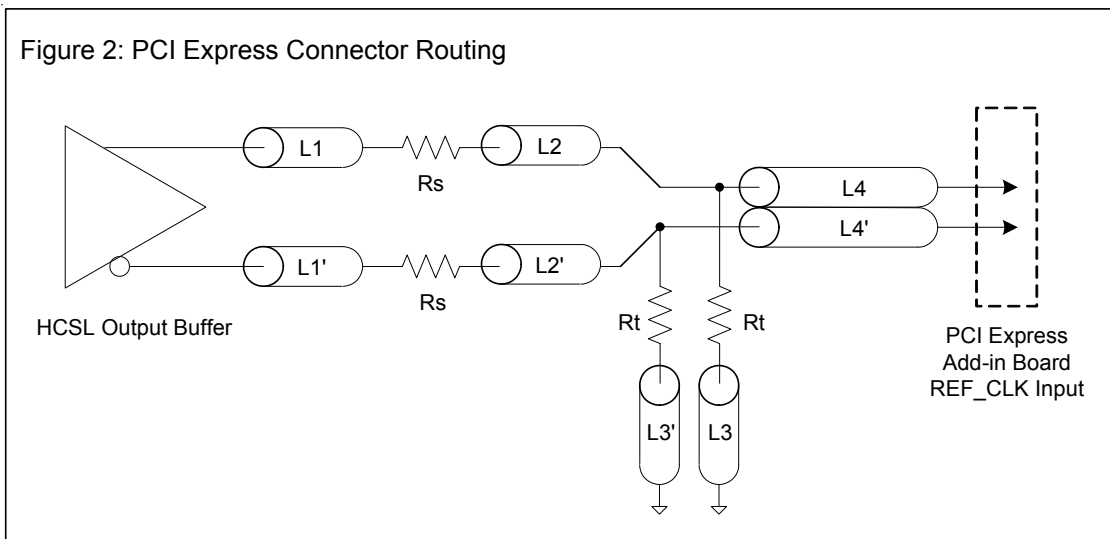
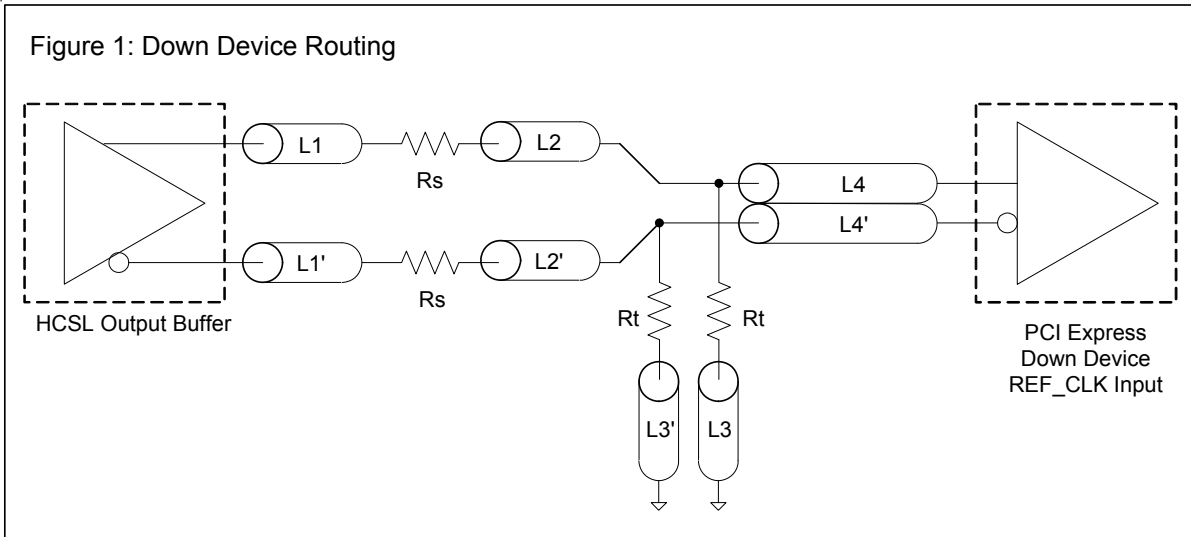

Alternative Termination for LVDS and other Common Differential Signals (figure 3)

Vdiff	Vp-p	Vcm	R1	R2	R3	R4	Note
0.45v	0.22v	1.08	33	150	100	100	
0.58	0.28	0.6	33	78.7	137	100	
0.80	0.40	0.6	33	78.7	none	100	ICS874003i-02 input compatible
0.60	0.3	1.2	33	174	140	100	Standard LVDS

R1a = R1b = R1

R2a = R2b = R2

Figure 3

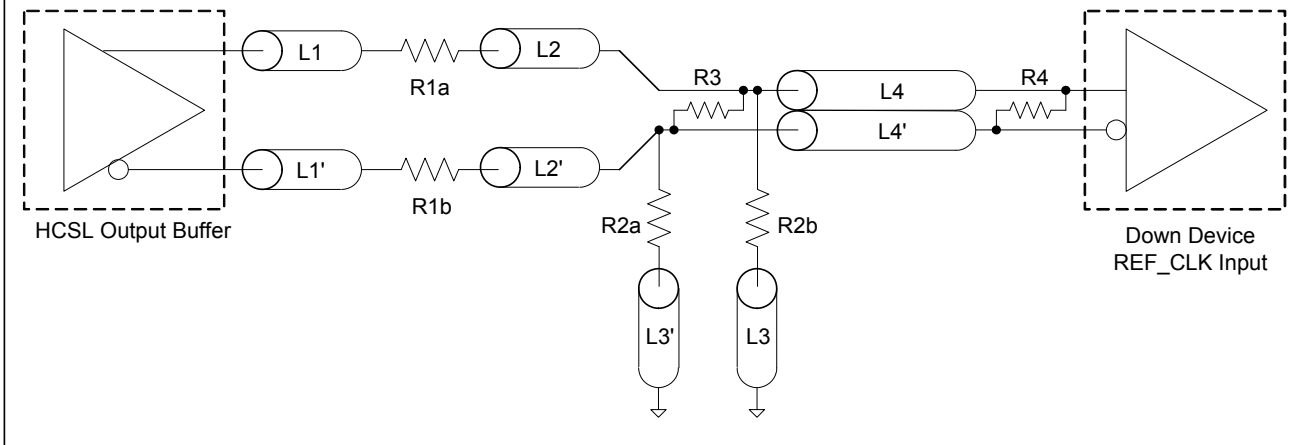

Cable Connected AC Coupled Application (figure 4)

Component	Value	Note
R5a, R5b	8.2K 5%	
R6a, R6b	1K 5%	
Cc	0.1 μF	
Vcm	0.350 volts	

Figure 4

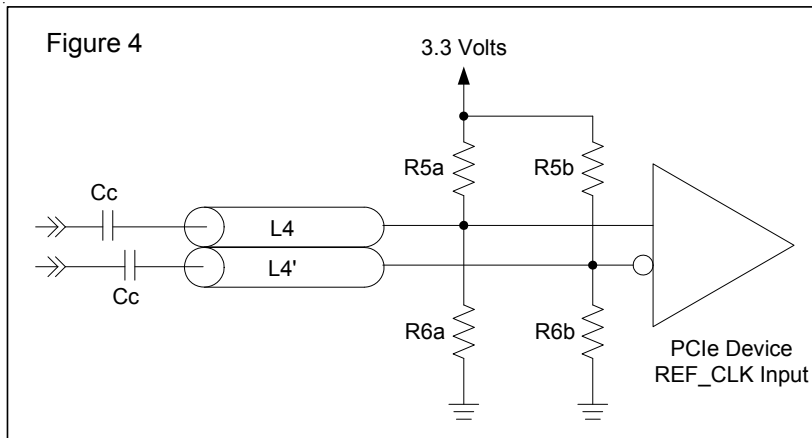

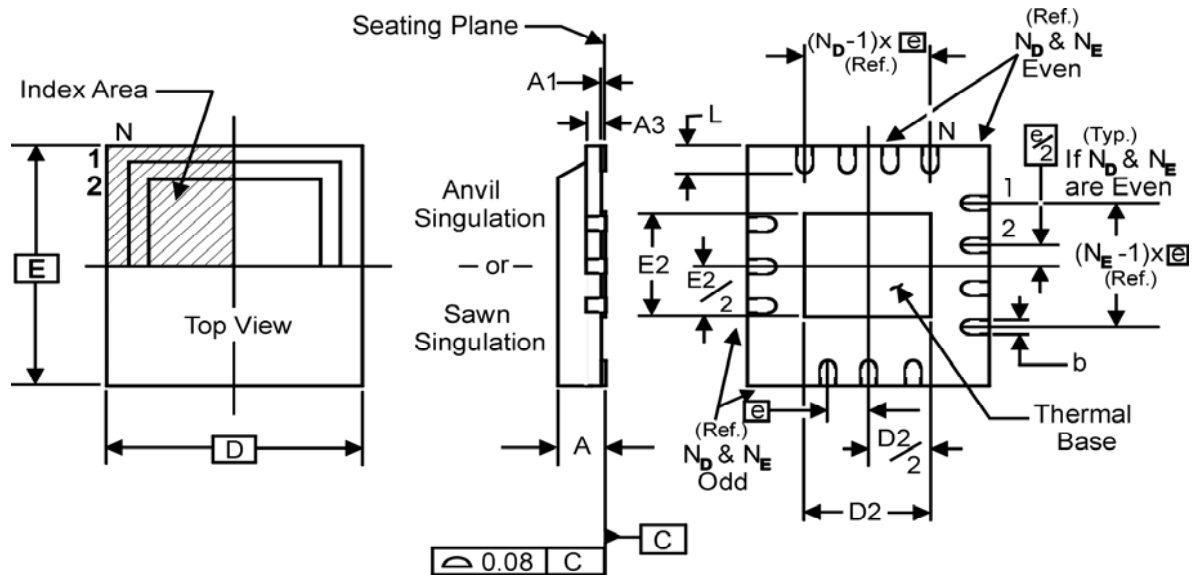

**THERMALLY ENHANCED, VERY THIN, FINE PITCH
QUAD FLAT / NO LEAD PLASTIC PACKAGE**

DIMENSIONS

SYMBOL	64L
N	64
N_D	16
N_E	16

DIMENSIONS (mm)

SYMBOL	MIN.	MAX.
A	0.8	1.0
A1	0	0.05
A3	0.25 Reference	
b	0.18	0.3
e	0.50 BASIC	
D x E BASIC	9.00 x 9.00	
D2 MIN. / MAX.	6.00	6.25
E2 MIN. / MAX.	6.00	6.25
L MIN. / MAX.	0.30	0.50

Ordering Information

Part / Order Number	Shipping Package	Package	Temperature	Difference
9ZX21201AKLF	Trays	64-pin MLF	0 to +70°C	W/O Byte 0 PLL Control
9ZX21201AKLFT	Tape and Reel	64-pin MLF	0 to +70°C	
9ZX21201BKLF	Trays	64-pin MLF	0 to +70°C	With Byte 0 PLL Mode Control
9ZX21201BKLFT	Tape and Reel	64-pin MLF	0 to +70°C	

"LF" designates PB-free configuration, RoHS compliant.

"A and B" are the device revision designators (will not correlate with the datasheet revision).

Revision History

Rev.	Issuer	Issue Date	Description	Page #
A	RDW	9/13/2011	1. Updated electrical tables with char data 2. Fixed minor typographical errors 3. Moved to final	Various
B	RDW	12/8/2011	1. Added B rev functionality description to Features, Benefits 2. Updated tDSPO_BYP parameter from +/-350ps to +/-250ps 3. Updated SMBus Byte 0 with B rev functionality 4. Updated ordering information to include B rev	1,7,11,15
C	RDW	4/18/2012	1. Updated Power connections table to be consistent with 9ZXL1231. 2. Updated Rp value for 85 ohm differential Zo from 43.2ohms to 42.2 OR 43.2 ohms to be consistent with Intel recommendations.	2,9
D	RDW	5/5/2014	1. Fixed error in feedback path on block diagram	1
E	RDW	11/19/2015	1. Updated the DIF_IN Input clock specification to align with the PCIe SIG specification.	6

IMPORTANT NOTICE AND DISCLAIMER

RENESAS ELECTRONICS CORPORATION AND ITS SUBSIDIARIES (“RENESAS”) PROVIDES TECHNICAL SPECIFICATIONS AND RELIABILITY DATA (INCLUDING DATASHEETS), DESIGN RESOURCES (INCLUDING REFERENCE DESIGNS), APPLICATION OR OTHER DESIGN ADVICE, WEB TOOLS, SAFETY INFORMATION, AND OTHER RESOURCES “AS IS” AND WITH ALL FAULTS, AND DISCLAIMS ALL WARRANTIES, EXPRESS OR IMPLIED, INCLUDING, WITHOUT LIMITATION, ANY IMPLIED WARRANTIES OF MERCHANTABILITY, FITNESS FOR A PARTICULAR PURPOSE, OR NON-INFRINGEMENT OF THIRD PARTY INTELLECTUAL PROPERTY RIGHTS.

These resources are intended for developers skilled in the art designing with Renesas products. You are solely responsible for (1) selecting the appropriate products for your application, (2) designing, validating, and testing your application, and (3) ensuring your application meets applicable standards, and any other safety, security, or other requirements. These resources are subject to change without notice. Renesas grants you permission to use these resources only for development of an application that uses Renesas products. Other reproduction or use of these resources is strictly prohibited. No license is granted to any other Renesas intellectual property or to any third party intellectual property. Renesas disclaims responsibility for, and you will fully indemnify Renesas and its representatives against, any claims, damages, costs, losses, or liabilities arising out of your use of these resources. Renesas' products are provided only subject to Renesas' Terms and Conditions of Sale or other applicable terms agreed to in writing. No use of any Renesas resources expands or otherwise alters any applicable warranties or warranty disclaimers for these products.

(Rev.1.0 Mar 2020)

Corporate Headquarters

TOYOSU FORESIA, 3-2-24 Toyosu,
Koto-ku, Tokyo 135-0061, Japan
www.renesas.com

Contact Information

For further information on a product, technology, the most up-to-date version of a document, or your nearest sales office, please visit:
www.renesas.com/contact/

Trademarks

Renesas and the Renesas logo are trademarks of Renesas Electronics Corporation. All trademarks and registered trademarks are the property of their respective owners.

X-ON Electronics

Largest Supplier of Electrical and Electronic Components

Click to view similar products for [Clock Buffer](#) category:

Click to view products by [Renesas](#) manufacturer:

Other Similar products are found below :

[MPC962309EJ-1H](#) [NB4N121KMNG](#) [IDT49FCT805ASO](#) [MK2308S-1HILF](#) [PL133-27GI-R](#) [NB3L02FCT2G](#) [NB3L03FCT2G](#)
[ZL40203LDG1](#) [ZL40200LDG1](#) [ZL40205LDG1](#) [9FG1200DF-1LF](#) [9FG1001BGLF](#) [ZL40202LDG1](#) [PI49FCT20802QE](#) [SL2305SC-1T](#)
[PI6C4931502-04LIE](#) [NB7L1008MNG](#) [NB7L14MN1G](#) [PI49FCT20807QE](#) [PI6C4931502-04LIEX](#) [ZL80002QAB1](#) [PI6C4931504-04LIEX](#)
[PI6C10806BLEX](#) [ZL40226LDG1](#) [ZL40219LDG1](#) [8T73S208B-01NLGI](#) [SY75578LMG](#) [PI49FCT32805QEX](#) [PL133-27GC-R](#)
[CDCV304PWG4](#) [MC10LVEP11DG](#) [MC10EP11DTG](#) [MC100LVEP11DG](#) [MC100E111FNG](#) [MC100EP11DTG](#) [NB6N11SMNG](#)
[NB7L14MMNG](#) [NB3N2304NZDTR2G](#) [NB6L11MMNG](#) [NB6L14MMNR2G](#) [NB6L611MNG](#) [PL123-02NGI-R](#) [NB3N111KMNR4G](#)
[ADCLK944BCPZ-R7](#) [ZL40217LDG1](#) [NB7LQ572MNG](#) [HMC940LC4BTR](#) [ADCLK946BCPZ-REEL7](#) [ADCLK946BCPZ](#)
[ADCLK846BCPZ-REEL7](#)