

D2-1 Family Audio SOC

D2-1 Family for Manufacturers of High-Performance Class-D Audio Amplifiers

FN6786
Rev. 3.00
Mar 18, 2019

The D2 Audio DSP D2-1 Family ([D2-81412](#), [D2-81431](#), [D2-81433](#), and [D2-81435](#)) is a fully self-contained 4-channel digital amplifier controller System-On-Chip (SOC). The D2-1 Family enables rapid system design for manufacturers of home theater receivers, multi-room distributed audio systems, and powered speakers.

The D2-1 Family contains a high-performance digital switching controller to play any input source on any output channel.

A configurable audio signal processor provides equalization, volume control, tone control, and compression for each channel, as well as crossover and power limiting for powered speaker applications.

The D2-1 Family includes 4-channels I²S/left-justified inputs (16-bit to 24-bit, 32kHz to 192kHz) and an optional S/PDIF receiver (16-bit to 24-bit).

Boot options include: Self-boot from an external serial ROM, asynchronous SCI slave boot, and serial slave boot from a host microcontroller.

See the Ordering Information table on [page 3](#) for additional information about support for D2 Audio DSP Sound Enhancement Algorithms firmware, as well as for SRS Labs™ and Dolby Labs™ algorithm support.

Features

- Powerful digital audio management: design dependent SRC, routing, mixing, multiple digital audio I/O, tone control, parametric EQ, and compression
- Reduced audio system cost for manufacturers of Class-D audio amplifiers
- Audio processing features enable optimized speaker performance and deliver dramatically improved sound quality
- Minimum development cost/risk/time-to-market
- Pure digital path
- Superior dynamic range
- >110dB SNR, <0.1% THD+N
- 20Hz-20kHz ±0.5dB frequency response

Complete Class-D Amplifier Controller SOC

- Digital switching controller
- Flexible audio input sources
- Multiple controller synchronization
- Bridge and non-bridged output topologies
- Standalone or microcontroller boot option
- Four channels
- Pb-free (RoHS compliant)

High-Performance Sound

- Unique performance for each part number
- Superior dynamic range
- >110 dB SNR, <0.1% THD+N
- 20Hz-20kHz ±0.5dB frequency response

Graceful Protection and Recovery

- Complete short-circuit, overcurrent, and overvoltage fault protection

Pure Digital Path

- Digital audio inputs support I²S and left-justified formats with linear PCM (32kHz to 192kHz, 16-bit to 24-bit)
- Digital audio input supports S/PDIF format with linear PCM (32kHz to 192kHz, 16-bit to 24-bit)

Multiple Part Offerings

- D2-81412-LR: 144 Ld LQFP supports D2 Audio DSP Sound Enhancement Algorithms
- D2-81431-LR: 128 Ld LQFP supports D2 Audio DSP Sound Enhancement Algorithms
- D2-81435-LR: 128 Ld LQFP supports D2 Audio DSP Sound Enhancement Algorithms and DTS™ (SRS) Technology

Related Literature

For a full list of related documents, visit our website:

- [D2-81412](#), [D2-81431](#), [D2-81433](#), and [D2-81435](#) device pages

Table of Contents

Ordering Information	3
D2-1 Family Architecture	4
Absolute Maximum Ratings	5
Thermal Information	5
Operating Conditions	5
Electrical Specifications	5
Switching Characteristics, Serial Audio Port	6
Switching Characteristics, 2-Wire Interface	7
Pin Configuration, 128 Ld LQFP Package	8
Pin Definitions, 128 Ld LQFP Package	8
Pin Descriptions, 128 Ld Package	11
Pin Configuration	14
Pin Definitions, 144 Ld LQFP Package	14
Pin Descriptions, 144-Pin Package	17
D2-1 Family Reset and Boot Modes	20
Reset	20
Boot Modes	20
Revision History	22
Trademarks	24
Disclaimer for Dolby Technology License Required Notice	24
Disclaimer for DTS (SRS) Technology License Required Notice	24
Package Outline Drawings	25

Ordering Information

PART NUMBER (Notes 1, 2)	PART MARKING	TEMP RANGE (°C)	PACKAGE (RoHS Compliant)	PKG. DWG. #
D2-81412-LR (Not recommended for new designs, recommended replacement: D2-81431-LR)	D2-81412-LR	-40 to 85	144 Ld LQFP	Q144.20x20B
D2-81431-LR	D2-81431-LR	-40 to 85	128 Ld LQFP	Q128.14x14
D2-81433-LR (No longer available, recommended replacement: D2-81435-LR)	D2-81433-LR	-40 to 85	128 Ld LQFP	Q128.14x14
D2-81435-LR	D2-81435-LR	-40 to 85	128 Ld LQFP	Q128.14x14

NOTES:

1. These Pb-free plastic packaged products employ special Pb-free material sets, molding compounds/die attach materials, and 100% matte tin plate plus anneal (e3 termination finish, which is RoHS compliant and compatible with both SnPb and Pb-free soldering operations). The Pb-free products are MSL classified at Pb-free peak reflow temperatures that meet or exceed the Pb-free requirements of IPC/JEDEC J STD-020.
2. For Moisture Sensitivity Level (MSL), see the [D2-81412](#), [D2-81431](#), [D2-81433](#), and [D2-81435](#) device pages. For more information about MSL, see [IB363](#).

D2-1 Family Architecture

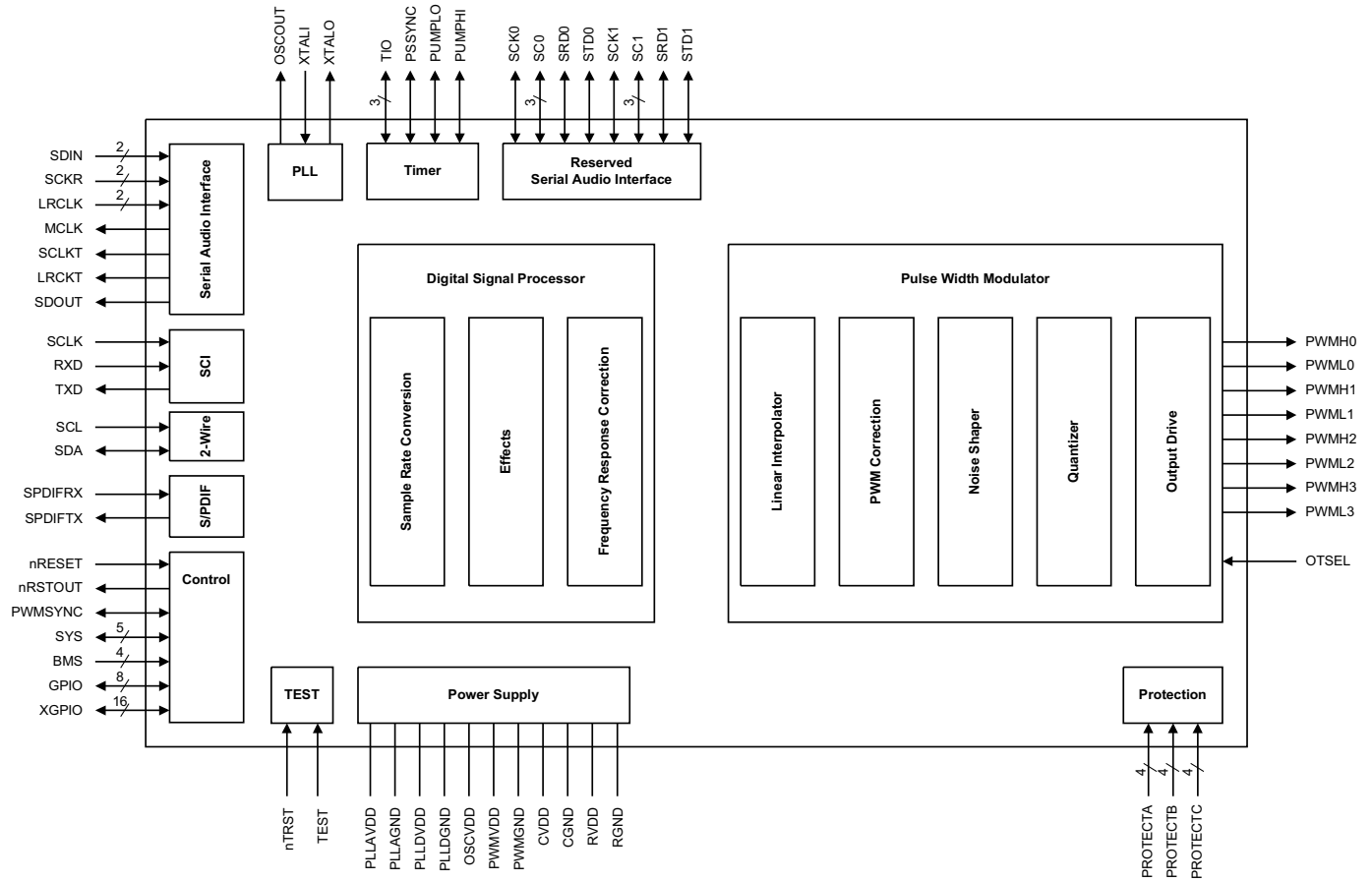

FIGURE 1. D2-1 FAMILY BLOCK DIAGRAM (144 LD PACKAGE)

Absolute Maximum Ratings

Supply Voltage RVDD, PWMVDD	-0.3V to 4.0V
Supply Voltage CVDD, PLLAVDD, PLLDVDD, OSCVDD	-0.3V to 2.4V
Input Voltage, any Input but XTALI	-0.3V to RVDD + 0.3V
Input Voltage XTALI	-0.3V to OSCVDD + 0.3V
Input Current, any Pin but Supplies	±10mA

Thermal Information

Thermal Resistance (Typical)	θ_{JA} (°C/W)	θ_{JC} (°C/W)
128 Ld LQFP (Notes 4, 5)	44	12
144 Ld LQFP (Notes 4, 5)	42	12
Junction Temperature (T_{JNC}) (Note 3)	+125°C	
Storage Temperature Range (T_{STG}) (Note 3)	-55°C to +150°C	
Pb-Free Reflow Profile	see TB493	

Operating Conditions

Operating Temperature (T_{MAX}) (Note 3)	-10°C to +85°C
--	----------------

CAUTION: Do not operate at or near the maximum ratings listed for extended periods of time. Exposure to such conditions can adversely impact product reliability and result in failures not covered by warranty.

NOTES:

- For both 128 Ld LQFP and 144 Ld LQFP.
- θ_{JA} is measured with the component mounted on a high-effective thermal conductivity test board in free air. See [TB379](#) for details.
- For θ_{JC} , the “case temp” location is taken at the package top center.

Electrical Specifications

PARAMETER	SYMBOL	MIN	TYP	MAX	UNIT
PIN CHARACTERISTICS $T_A = +25^\circ\text{C}$, CVDD = PLLAVDD = PLLDVDD = OSCVDD = 1.8V ±5%, RVDD = PWMVDD = 3.3V ±10%. All grounds at 0.0V. All voltages referenced to ground.					
High Level Input Drive Voltage (Note 6)	V_{IH}	2.0	-	-	V
Low Level Input Drive Voltage (Note 6)	V_{IL}	-	-	0.8	V
High Level Output Drive Voltage (Note 7) $I_{OUT} = \text{-Pad Drive}$	V_{OH}	RVDD - 0.3	-	-	V
Low Level Output Drive Voltage (Note 7) $I_{OUT} = \text{+Pad drive}$	V_{OL}	-	-	0.3	V
High Level Input Drive Voltage (Note 8)	V_{IHx}	0.7	-	OSCVDD	V
Low Level Input Drive Voltage (Note 8)	V_{ILx}	-	-	0.3	V
High Level Output Drive Voltage OSCOUT pin	V_{OH0}	PLLDVDD - 0.3	-	-	V
Low Level Output Drive Voltage OSCOUT pin	V_{OLO}	-	-	0.3	V
Input Leakage Current	I_{IN}	-	-	±10	uA
Input Capacitance	C_{IN}	-	9	-	pF
Output Capacitance	C_{OUT}	-	9	-	pF
POWER REQUIREMENTS Typical supply currents measured at $T_A = +25^\circ\text{C}$, PLL at 300MHz, OSC at 27MHz, core running at 150MHz with typical audio data traffic. Minimum supply currents are measured in full power-down configuration.					
Core Supply Pins	CVDD	1.7	1.8	1.9	V
		0.01	325		mA
Digital I/O Pad Ring Supply Pins	RVDD	3.0	3.3	3.6	V
		0.01	10		mA
PWM I/O Pad Ring Supply Pins	PWMVDD	3.0	3.3	3.6	V
		0.01	5		mA

Electrical Specifications (Continued)

PARAMETER	SYMBOL	MIN	TYP	MAX	UNIT
Analog Supply Pins (PLL)	PLLAVDD	1.7	1.8	1.9	V
		0.01	10		mA
	PLLDVDD	1.7	1.8	1.9	V
		0.01	2		mA
	OSCVDD	1.7	1.8	1.9	V
		0.01	4		mA

NOTES:

- 6. All input pins except XTALI.
- 7. All digital output pins.
- 8. For XTALI input overdrive operation only.

Switching Characteristics, Serial Audio Port $T_A = +25^\circ\text{C}$, $CVDD = PLLAVDD = PLLDVDD = OSCVDD = 1.8\text{V} \pm 5\%$, $RVDD = PWMVDD = 3.3\text{V} \pm 10\%$. All grounds at 0.0V. All voltages referenced to ground.

SYMBOL	DESCRIPTION	MIN	TYP	MAX	UNIT
$t_c\text{SCLK}$	SCKRx frequency - SCKR0, SCKR1			12.5	MHz
$t_w\text{SCLK}$	SCKRx pulse width (high and low) - SCKR0, SCKR1	40			ns
$t_s\text{LRCLK}$	LRCKRx setup to SCLK rising - LRCKR0, LRCKR1	20			ns
$t_h\text{LRCLK}$	LRCKRx hold from SCLK rising - LRCKR0, LRCKR1	20			ns
$t_s\text{SDI}$	SDINx setup to SCLK rising - SDIN0, SDIN1	20			ns
$t_h\text{SDI}$	SDINx hold from SCLK rising - SDIN0, SDIN1	20			ns
$t_d\text{SDO}$	SDOUTx delay from SCLK falling			20	ns

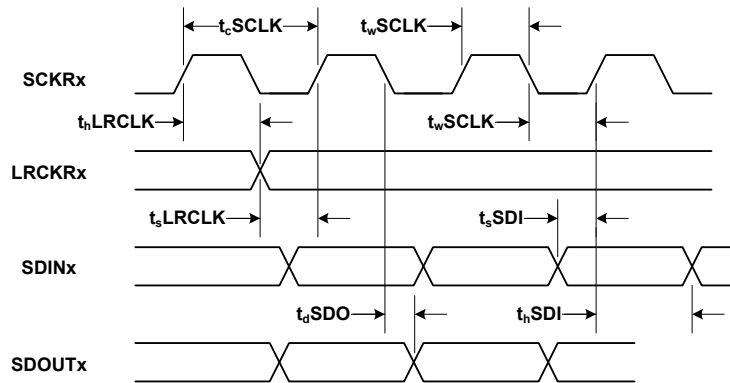

FIGURE 2. SERIAL AUDIO PORT TIMING

SERIAL AUDIO INTERFACE (SAI PORTS)

The D2-1 Family IC contains one SAI port for each pair of channels. Each input can support an individually selectable sample rate from 32kHz to 192kHz. All digital audio inputs are 3.3V CMOS logic. The SAI port is designed to interface with standard digital audio components and to accept I²S or left-justified data formats.

For the I²S format, the left channel data is read when LRCK is low. For the left-justified format, the left channel data is read when LRCK is high. Both formats require data to be valid on the rising edge of SCLK and sent MSB-first on SDIN with 32 bits of data per channel. Each set of digital inputs runs asynchronously to the others and accepts different sample rates and formats.

Note: This port is entirely independent from the Reserved SAI port. The Reserved SAI port is optional for a particular design.

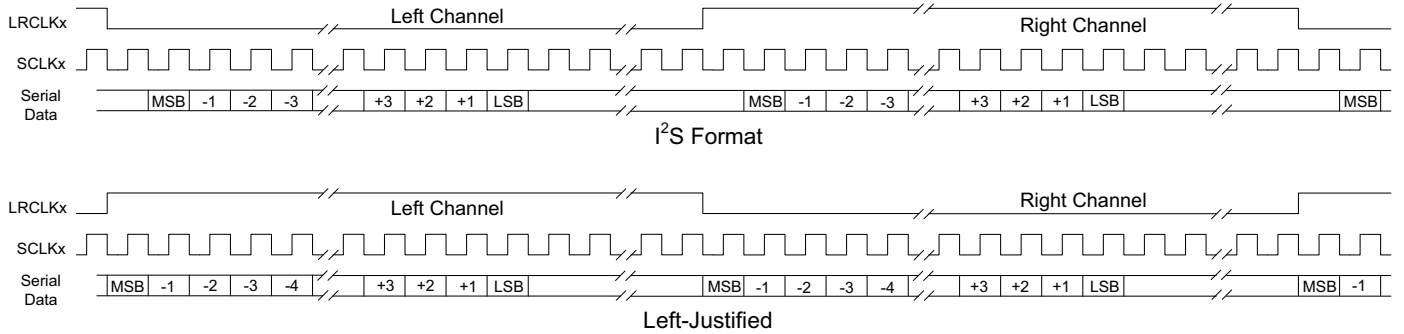

FIGURE 3. SAI PORT DATA FORMATS

Switching Characteristics, 2-Wire Interface $T_A = +25^\circ\text{C}$, $CVDD = PLLAVD = PLLDVDD = OSCVDD = 1.8\text{V} \pm 5\%$, $RVDD = PWMVDD = 3.3\text{V} \pm 10\%$. All grounds at 0.0V. All voltages referenced to ground.

SYMBOL	DESCRIPTION	MIN	MAX	UNIT
fSCL	SCL frequency		100	kHz
t _{buf}	Bus free time between transmissions	4.7		μs
t _{wlow} SCLx	SCL clock low	4.7		μs
t _{whigh} SCLx	SCL clock high	4.0		μs
t _s STA	Setup time for a (repeated) Start	4.7		μs
t _h STA	Start condition Hold time	4.0		μs
t _h SDAx	SDA hold from SCL falling (Note 9)	0		μs
t _s SDAx	SDA setup time to SCL rising	250		ns
t _d SDAx	SDA output delay time from SCL falling		3.5	μs
t _r	Rise time of both SDA and SCL		1	μs
t _f	Fall time of both SDA and SCL		300	ns
t _s STO	Setup time for a Stop condition	4.7		μs

NOTE:

9. Data must be held sufficient time to bridge the 300ns SCL transition time.

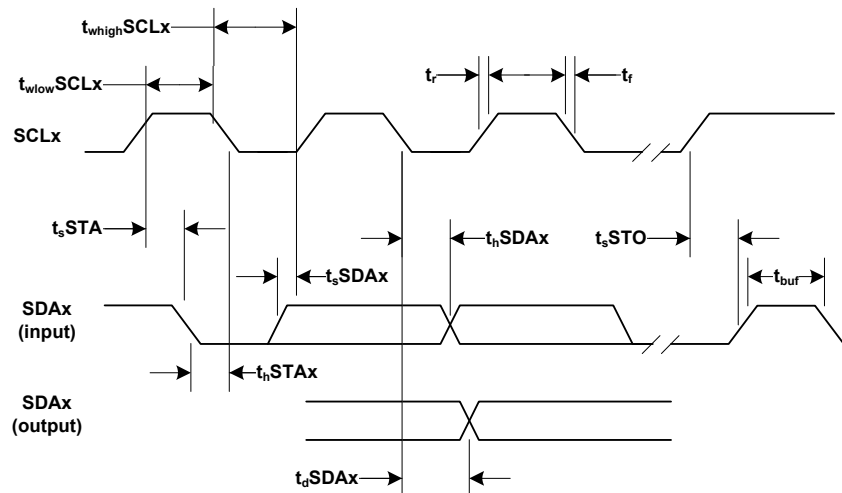
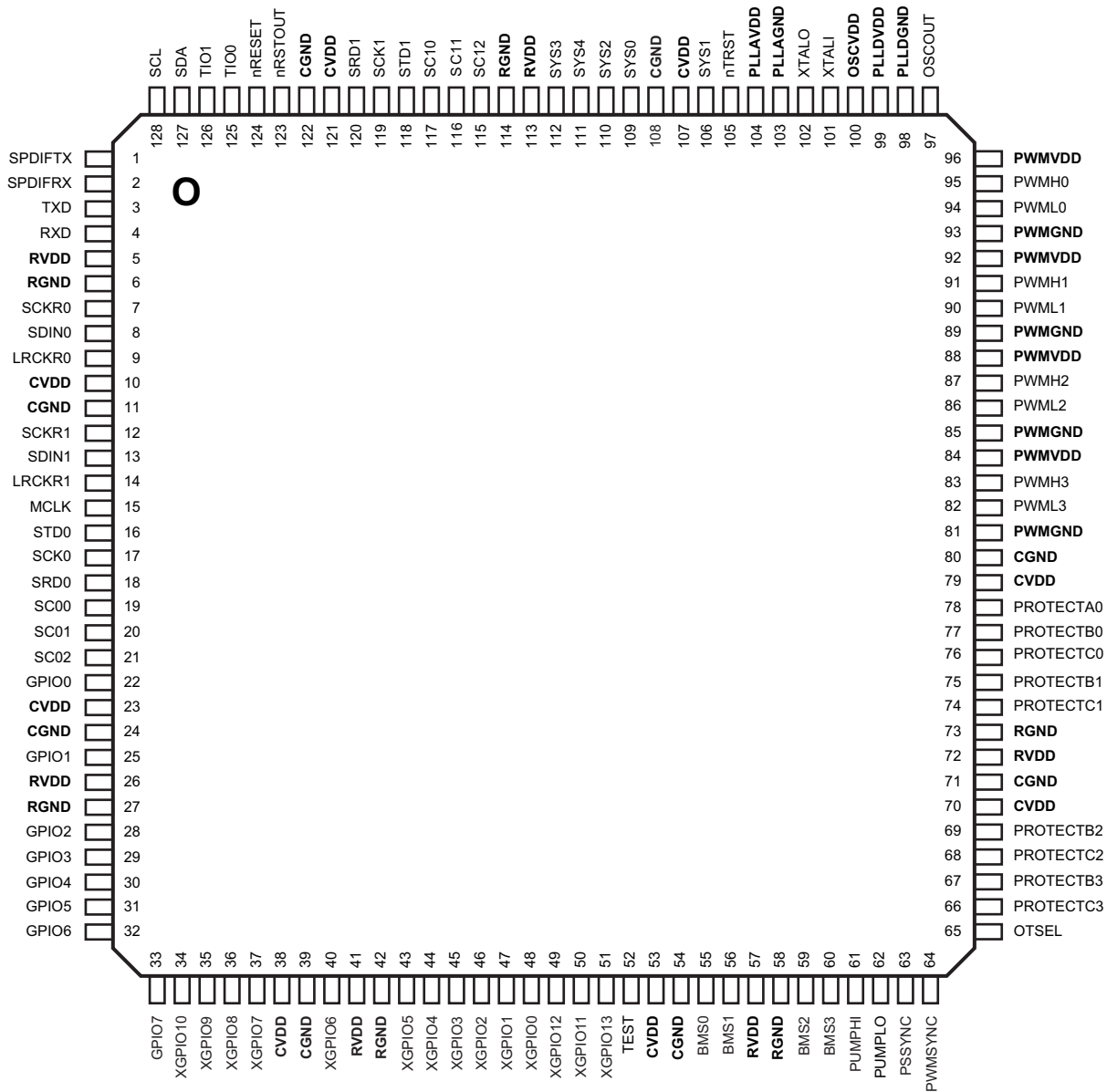

FIGURE 4. 2-WIRE INTERFACE TIMING

Pin Configuration, 128 Ld LQFP Package

D2-1 Family
(128 LD LQFP)
TOP VIEW



Pin Definitions, 128 Ld LQFP Package

PIN NUMBER	PORT NAME	TYPE	DESCRIPTION
SERIAL AUDIO INTERFACE (SAI) PINS			
15	MCLK	Output	Master Clock
7	SCKR0	I/O	Serial Audio Bit Clock Receiver 0
9	LRCKR0	I/O	Serial Audio Left/Right Clock Receiver 0
8	SDIN0	Input	Serial Audio Data In 0
12	SCKR1	I/O	Serial Audio Bit Clock Receiver 1
14	LRCKR1	I/O	Serial Audio Left/Right Clock Receiver 1

Pin Definitions, 128 Ld LQFP Package (Continued)

PIN NUMBER	PORT NAME	TYPE	DESCRIPTION
13	SDIN1	Input	Serial Audio Data In 1
SPDIF PINS			
1	SPDIFTX	Output	S/PDIF data output
2	SPDIFRX	Input	S/PDIF data input
PWM PINS			
95	PWMH0	Output	Channel 0 PWM high-side output
94	PWML0	Output	Channel 0 PWM low-side output
91	PWMH1	Output	Channel 1 PWM high-side output
90	PWML1	Output	Channel 1 PWM low-side output
87	PWMH2	Output	Channel 2 PWM high-side output
86	PWML2	Output	Channel 2 PWM low-side output
83	PWMH3	Output	Channel 3 PWM high-side output
82	PWML3	Output	Channel 3 PWM low-side output
65	OTSEL	Input	Output topology select input
64	PWMSYNC	I/O	PWM sync
2-WIRE SERIAL PINS			
128	SCL	I/O	Two-wire serial clock
127	SDA	I/O	Two-wire serial data
XGPIO PINS			
34, 35, 36, 37, 40, 43, 44, 45, 46, 47, 48	XGPIO[10:0]	I/O	General purpose I/O
50	XGPIO[11]	I/O	
49	XGPIO[12]	I/O	
51	XGPIO[13]	I/O	
GPIO PINS			
33, 32, 31, 30, 29, 28, 25, 22	GPIO[7:0]	I/O	General purpose I/O
RESET AND TEST PINS			
124	nRESET	Input	Reset, active low
123	nRSTOUT	Output	Reset output, active low output
105	nTRST	Input	Test reset, active low
52	TEST	Input	Hardware test pin
CRYSTAL OSCILLATOR AND PLL PINS			
97	OSCOUT	Output	Oscillator output to slave device
101	XTALI	Input	Crystal oscillator input
102	XTALO	Output	Crystal oscillator output

Pin Definitions, 128 Ld LQFP Package (Continued)

PIN NUMBER	PORT NAME	TYPE	DESCRIPTION
SYSTEM CONFIGURATION PINS			
109	SYS0	I/O	Reserved for factory test
106	SYS1	I/O	
110	SYS2	I/O	
112	SYS3	I/O	
111	SYS4	I/O	
SERIAL COMMUNICATIONS INTERFACE (SCI) PINS			
4	RXD	I/O	SCI receive data
3	TXD	I/O	SCI transmit data
RESERVED SERIAL AUDIO INTERFACE PINS			
16	STD0	I/O	Reserved Serial Audio Interface 0 Tx Data or GPIO
17	SCK0	I/O	Reserved Serial Audio Interface 0 Clock or GPIO
18	SRD0	I/O	Reserved Serial Audio Interface 0 Rx Data or GPIO
19	SC00	I/O	Reserved Serial Audio Interface 0 Control 0 or GPIO
20	SC01	I/O	Reserved Serial Audio Interface 0 Control 1 or GPIO
21	SC02	I/O	Reserved Serial Audio Interface 0 Control 2 or GPIO
118	STD1	I/O	Reserved Serial Audio Interface 1 Tx Data or GPIO
119	SCK1	I/O	Reserved Serial Audio Interface 1 Clock or GPIO
120	SRD1	I/O	Reserved Serial Audio Interface 1 Rx Data or GPIO
117	SC10	I/O	Reserved Serial Audio Interface 1 Control 0 or GPIO
116	SC11	I/O	Reserved Serial Audio Interface 1 Control 1 or GPIO
115	SC12	I/O	Reserved Serial Audio Interface 1 Control 2 or GPIO
BOOT MODE SELECT PINS			
55	BMS0	Input	Boot Mode Select 0
56	BMS1	Input	Boot Mode Select 1
59	BMS2	Input	Boot Mode Select 2
60	BMS3	Input	Boot Mode Select 3
TIMER (TIO) PINS			
126, 125	TIO[1:0]	I/O	Timer I/O ports
61	PUMPHI	I/O	Power supply pump control, high-side or GPIO
62	PUMPLO	I/O	Power supply pump control, low-side or GPIO
63	PSSYNC	I/O	Power supply synchronization or GPIO
PWM PROTECTION PINS			
78	PROTECTAO	I/O	PWM temperature status input, or GPIO
67, 69, 75, 77	PROTECTB[3:0]	I/O	PWM overcurrent protection inputs, or GPIO
66, 68, 74, 76	PROTECTC[3:0]	I/O	PWM shoot-through current inputs or GPIO
POWER PINS			
104	PLLAVDD	Power	PLL analog power
103	PLLAGND	Ground	PLL analog ground

Pin Definitions, 128 Ld LQFP Package (Continued)

PIN NUMBER	PORT NAME	TYPE	DESCRIPTION
99	PLLDVDD	Power	PLL digital power
98	PLLDGND	Ground	PLL digital ground
100	OSCVDD	Power	Oscillator power
121, 107, 79, 70, 53, 38, 23, 10	CVDD	Power	Core power, 8 pins
122, 108, 80, 71, 54, 39, 24, 11	CGND	Ground	Core ground, 8 pins
96, 92, 88, 84	PWMVDD	Power	PWM output pin power, four pins
93, 89, 85, 81	PWMGND	Ground	PWM output pin ground, four pins
113, 72, 57, 41, 26, 5	RVDD	Power	Digital pad ring power, six pins
114, 73, 58, 42, 27, 6	RGND	Ground	Digital pad ring ground, six pins

Pin Descriptions, 128 Ld Package

Pins are 100% firmware and Reference Design Platform (RDP) Package dependent for their functionality. Output pins have one of three drive strengths: 4mA, 8mA, or 16mA. These strengths are characterized by the current that the pin sources or sinks at the specified output voltage level.

SERIAL AUDIO INTERFACE (SAI) PINS

MCLK Master Clock Output

Master Clock output for external ADC/DAC components with 8mA drive strength. This pin drives low on reset. MCLK is also used by test hardware to monitor various internal clocks.

SCKR0 SAI Receiver Bit Clock 1

The SAI Receiver 0 bit clock is an output when the D2-1 Family is a master and is an input when the D2-1 Family is a slave. Defaults to an input on reset. Output has 4mA drive strength. Input has hysteresis.

LRCKR0 SAI Receiver Left/Right Clock 0

The SAI Receiver 0 left/right audio frame clock is an output when the D2-1 Family is a master and is an input when the D2-1 Family is a slave. Defaults to an input on reset. Output has 4mA drive strength. Input has hysteresis.

SDIN0 SAI Receiver Serial Data Input 0

SAI Receiver 0 data input.

SCKR1 SAI Receiver Bit Clock 1

The SAI Receiver 1 bit clock is an output when the D2-1 Family is a master and is an input when the D2-1 Family is a slave. Defaults to an input on reset. Output has 4mA drive strength. Input has hysteresis.

LRCKR1 SAI Receiver Left/Right Clock 1

The SAI Receiver 1 left/right audio frame clock is an output when the D2-1 Family is a master and is an input when the D2-1 Family is a slave. Defaults to an input on reset. Output has 4mA drive strength. Input has hysteresis.

SDIN1 SAI Receiver Serial Data Input 1

SAI Receiver 1 data input.

S/PDIF PINS

SPDIFRX S/PDIF Data Input

This pin is the S/PDIF audio input and accepts a 3.3V stereo input up to 192kHz. To drive this pin, appropriate buffer and/or isolation circuits may be necessary to convert the S/PDIF cable input signal to clean logic levels.

SPDIFTX S/PDIF Data Output

This pin is the S/PDIF audio output and drives a 3.3V stereo output up to 192kHz.

PWM PINS

PWMxH PWM High-side Driver Outputs

PWM high-side driver outputs, where x is 0 to 3, with 16mA drive strength. This pin drives to the state determined by OTSEL on reset.

PWMxL PWM Low-Side Driver Outputs

PWM low-side driver outputs, where x is 0 to 3, with 16mA drive strength. Pin drives low on reset.

OTSEL Output Topology Select Input

Output topology select input. The OTSEL pin state controls the PWMxH drive polarity. OTSEL is typically tied either high for active-low PWMxH FET drivers, or tied low for active-high PWMxH FET drivers.

PWMSYNC PWM Synchronization

PWM synchronization port with 4mA drive. Used in multi-D2-1 Family configurations to synchronize the PWM controllers. The master D2-1 Family drives synchronization data to the slave D2-1 Family(ies), so this pin is an output on the master D2-1 Family and an input on the slave D2-1 Family(ies). This pin floats on reset.

2-WIRE SERIAL PINS**SCL Serial Clock**

Two-Wire Serial clock port, open drain driver with 4mA drive strength. This bidirectional signal is used by both the master and slave controllers for clock signaling.

SDA Serial Data

Two-Wire Serial data port, open drain driver with 4mA drive strength. This bidirectional signal is used by both the master and slave controllers for data transport.

XGPIO PINS**XGPIO[10:0] General Purpose I/O**

Bidirectional GPIO port with 4mA driver. Resets to the input port.

XGPIO[11] General Purpose I/O

Bidirectional GPIO port with 4mA driver. Resets to the input port.

XGPIO[12] General Purpose I/O

Bidirectional GPIO port with 4mA driver. Resets to the input port.

XGPIO[13] General Purpose I/O

Bidirectional GPIO port with 4mA driver. Resets to the input port.

RESET AND TEST PINS**nRESET System Reset Input**

Active low reset input with hysteresis. A low level activates system level reset, which initializes all internal logic and program operations. The system latches the boot mode selection on the IRQ input pins on the rising edge.

nRSTOUT System Reset Output

Active low reset output with 4mA driver. This pin drives low on any POR output, 3.3V brownout detector, or 1.8V brownout detector.

TEST Test Mode Input

Hardware test mode control. For D2 Audio DSP usage only. Must be tied low.

nTRST Test Reset Input

Active low test port reset. A low level activates test reset and initializes test hardware. Must be driven low with nRESET.

CRYSTAL OSCILLATOR AND PLL PINS**OSCOUT Oscillator Output**

Analog oscillator output to slave the D2-1 Family devices. On reset, OSCOUT drives a buffered version of the crystal oscillator signal from the XTALI pin. Can be turned off by program control.

XTALI Crystal Oscillator Input

Crystal oscillator analog input port. An external clock source can be driven into the this port. In multi-D2-1 Family systems, the OSCOUT from the master D2-1 Family drives the XTALI pin.

XTALO Crystal Oscillator Output

Crystal oscillator analog output port. This pin must be open when using an external clock source.

GPIO PINS**GPIO[7:0] General Purpose I/O**

Bidirectional GPIO ports with 4mA driver. Resets to the input ports.

SYSTEM CONFIGURATION PINS**SYS0 System Configuration Data 0**

Reserved for factory test. Tie low with a 10kΩ resistor.

SYS1 System Configuration Data 1

Reserved for factory test. Tie high with a 10kΩ resistor.

SYS2 System Configuration Data 2

Reserved for factory test. Tie high with a 10kΩ resistor.

SYS3 System Configuration Data 3

Reserved for factory test. Tie high with a 10kΩ resistor.

SYS4 System Configuration Data 4

Reserved for factory test. Tie high with a 10kΩ resistor.

SERIAL COMMUNICATIONS INTERFACE (SCI) PINS**RXD Receive Data**

Serial communications receiver data with 4mA drive. Resets to the input port. Can be configured to GPIO.

TXD Transmit Data

Serial communications transmitter data with 4mA drive. Resets to the input port. Can be configured to GPIO.

OPTIONAL/RESERVED FUNCTION PINS**SCK0 Reserved Serial Audio Interface 0 Serial Clock**

Serial Audio Interface 0 serial clock port with 4mA driver and hysteresis receiver. Resets to the input port. Can be configured as GPIO.

SC00-SC02 Reserved Serial Audio Interface 0 Serial Control

0 serial control port with 4mA driver. Resets to the input port. Can be configured as GPIO.

STD0 Reserved Serial Audio Interface 0 Serial Transmit Data

Serial Audio Interface 0 serial transmit data port with 4mA driver. Resets to the input port. Can be configured as GPIO.

SRD0 Reserved Serial Audio Interface 0 Serial Receive Data

Serial Audio Interface 0 serial receive data port with 4mA driver. Resets to the input port. Can be configured as GPIO.

SCK1 Reserved Serial Audio Interface 1 Serial Clock

Serial Audio Interface 1 serial clock port with 4mA driver and hysteresis receiver. Resets to the input port. Can be configured as GPIO.

SC10-SC12 Reserved Serial Audio Interface 1 Serial Control

Serial Audio Interface 1 serial control port with 4mA driver. Resets to the input port. Can be configured as GPIO.

STD1 Reserved Serial Audio Interface 1 Serial Transmit Data

Serial Audio Interface 1 serial transmit data port with 4mA driver. Resets to the input port. Can be configured as GPIO.

SRD1 Reserved Serial Audio Interface 1 Serial Receive Data

Serial Audio Interface 1 serial receive data port with 4mA driver. Resets to the input port. Can be configured as GPIO.

BOOT MODE SELECT PINS**BMS[3:0] Boot Mode Select Inputs**

External boot mode select inputs. On nRESET deassertion, these pins provide the boot mode selection.

TIMER (TIO) PINS**TIO[1:0] Timer**

Timer I/O ports with 4mA driver. Can be configured as GPIO.

PUMPHI Power Supply Pump High

High-side power supply pump output with 16mA driver. Can be configured as GPIO. Drives low on reset. Provides control for operating an external switching power supply.

PUMPLO Power Supply Pump Low

Low-side power supply pump output with 16mA driver. Can be configured as GPIO. Drives low on reset. Provides control means for operating an external switching power supply.

PSSYNC Power Supply Synchronization

Switching power supply synchronization signal with 16mA driver. Can be configured as GPIO. Resets to the input port.

PWM PROTECTION PINS**PROTECTA0 PWM Temperature Protection Input**

PWM temperature protection input with hysteresis. Can be configured as GPIO. In this instance, the GPIO pin has a 4mA driver.

PROTECTB[3:0] PWM Overcurrent Protection Inputs

PWM overcurrent protection inputs with hysteresis. Can be configured as GPIO. In this instance, the GPIO pins each have a 4mA driver. Each PWMOCPP input is associated with the corresponding PWM driver channel.

PROTECTC[3:0] PWM Shoot-Through Current Protection

PWM shoot-through-current protection inputs with hysteresis. In this instance, the GPIO pins each have a 4mA driver. Can be configured as GPIO. Each PWMSTC input is associated with the corresponding PWM driver channel.

POWER PINS**PLLAIDD/PLLAGND PLL Analog power and ground**

PLL analog supply/return. This 1.8V supply is used for the jitter critical sections of the PLL.

PLLDVDD/PLLDGND PLL Digital power and ground

PLL digital supply/return. This 1.8V supply is used for the “dirty” sections of the PLL and provides the pad supplies for all of the analog pads.

Note: PLLDGND and CGND are connected through the substrate.

OSCVDD Oscillator power

Oscillator supply. This 1.8V supply is used for the crystal oscillator and oscillator bias circuits only.

CVDD/CGND Core power and ground

Core supply/return. This 1.8V supply is used in the chip interior logic and pad ring interfaces. Eight core supply pad pairs are internally connected around the pad ring.

PWMVDD/PWMGND PWM driver power and ground

PWM I/O pad driver supply/return. This 3.3V supply is used for the PWM pad drivers only. There are four PWM internally connected supply pairs, one for each PWM data channel.

RVDD/RGND Pad Ring power and ground

Ring I/O pad driver supply/return. This 3.3V supply is used for all the digital I/O pad drivers and receivers except for the PWM and analog pads. Six ring supply pairs are internally connected around the pad ring.

Pin Configuration

D2-1 Family
(144 LD LQFP)
TOP VIEW

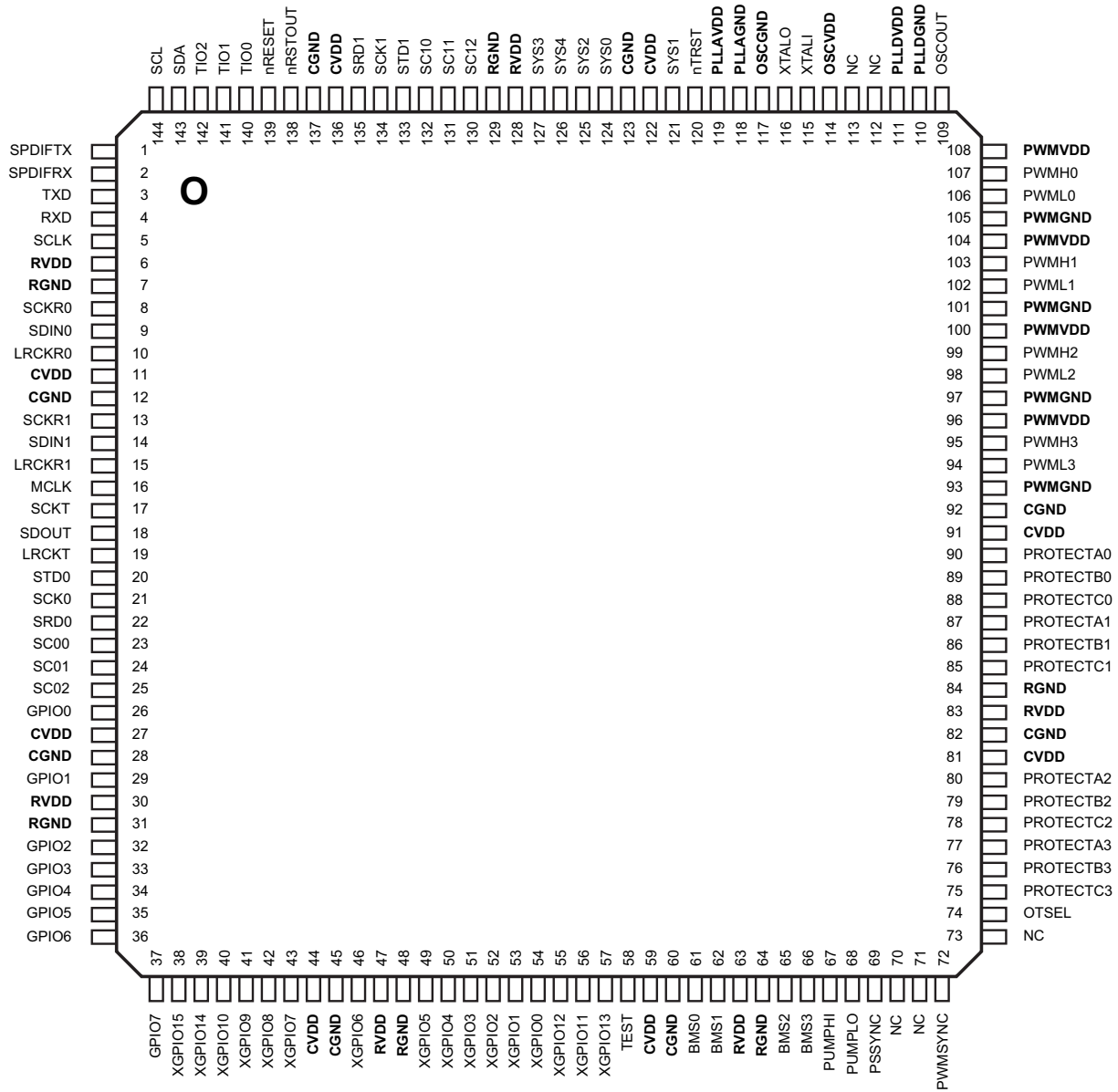

Pin Definitions, 144 Ld LQFP Package

PIN NUMBER	PORT NAME	TYPE	DESCRIPTION
SERIAL AUDIO INTERFACE (SAI) PINS			
16	MCLK	Output	Master clock output
8	SCKR0	I/O	Serial Audio Input 0 clock receiver
10	LRCKR0	I/O	Serial Audio Input 0 left/right clock receiver
9	SDIN0	Input	Serial Audio Input 0 data
13	SCKR1	I/O	Serial Audio Input Clock 1 receiver
15	LRCKR1	I/O	Serial Audio Input 1 left/right clock receiver

Pin Definitions, 144 Ld LQFP Package (Continued)

PIN NUMBER	PORT NAME	TYPE	DESCRIPTION
14	SDIN1	Input	Serial Audio Input 1 data
17	SCKT	I/O	Serial Audio Output clock transmit
19	LRCKT	I/O	Serial Audio Output left/right clock transmit
18	SDOUT	Output	Serial Audio Output
S/PDIF			
1	SPDIFTX	Output	S/PDIF data out
2	SPDIFRX	Input	S/PDIF data in
PWM PINS			
107	PWMH0	Output	Channel 0 PWM high-side output
106	PWML0	Output	Channel 0 PWM low-side output
103	PWMH1	Output	Channel 1 PWM high-side output
102	PWML1	Output	Channel 1 PWM low-side output
99	PWMH2	Output	Channel 2 PWM high-side output
98	PWML2	Output	Channel 2 PWM low-side output
95	PWMH3	Output	Channel 3 PWM high-side output
94	PWML3	Output	Channel 3 PWM low-side output
74	OTSEL	Input	Output topology select input
72	PWMSYNC	I/O	PWM sync
2-WIRE SERIAL PINS			
144	SCL	I/O	Two-wire serial clock
143	SDA	I/O	Two-wire serial data
XGPIO PINS			
43, 46, 49, 50, 51, 52, 53, 54	XGPIO[7:0]	I/O	General purpose I/O
38, 39, 57, 55, 56, 40, 41, 42	XGPIO[15:8]	I/O	
RESET AND TEST PINS			
139	nRESET	Input	Reset, active low
138	nRSTOUT	Output	Reset output, active low output
120	nTRST	Input	Test reset, active low
58	TEST	Input	Hardware test pin
CRYSTAL OSCILLATOR AND PLL PINS			
109	OSCOUT	Output	Oscillator output to slave device
115	XTALI	Input	Crystal oscillator input
116	XTALO	Output	Crystal oscillator output
GPIO PINS			
37, 36, 35, 34, 33, 32, 29, 26	GPIO[7:0]	I/O	General purpose I/O

Pin Definitions, 144 Ld LQFP Package (Continued)

PIN NUMBER	PORT NAME	TYPE	DESCRIPTION
SYSTEM CONFIGURATION PINS			
124	SYS0	I/O	Reserved for factory test
121	SYS1	I/O	
125	SYS2	I/O	
127	SYS3	I/O	
126	SYS4	I/O	
SERIAL COMMUNICATIONS INTERFACE (SCI) PINS			
5	SCLK	I/O	SCI clock
4	RXD	I/O	SCI receive data
3	TXD	I/O	SCI transmit data
RESERVED SERIAL AUDIO INTERFACE PINS			
20	STD0	I/O	Reserved Serial Audio Interface 0 Tx Data or GPIO
21	SCK0	I/O	Reserved Serial Audio Interface 0 Clock or GPIO
22	SRD0	I/O	Reserved Serial Audio Interface 0 Rx Data or GPIO
23	SC00	I/O	Reserved Serial Audio Interface 0 Control 0 or GPIO
24	SC01	I/O	Reserved Serial Audio Interface 0 Control 1 or GPIO
25	SC02	I/O	Reserved Serial Audio Interface 0 Control 2 or GPIO
133	STD1	I/O	Reserved Serial Audio Interface 1 Tx Data or GPIO
134	SCK1	I/O	Reserved Serial Audio Interface 1 Clock or GPIO
135	SRD1	I/O	Reserved Serial Audio Interface 1 Rx Data or GPIO
132	SC10	I/O	Reserved Serial Audio Interface 1 Control 0 or GPIO
131	SC11	I/O	Reserved Serial Audio Interface 1 Control 1 or GPIO
130	SC12	I/O	Reserved Serial Audio Interface 1 Control 2 or GPIO
BOOT MODE SELECT PINS			
61	BMS0	Input	Boot Mode Select 0
62	BMS1	Input	Boot Mode Select 1
65	BMS2	Input	Boot Mode Select 2
66	BMS3	Input	Boot Mode Select 3
TIMER (TIO) PINS			
142, 141, 140	TIO[2:0]	I/O	Timer I/O ports
67	PUMPHI	I/O	Power supply pump control, high-side or GPIO
68	PUMPLO	I/O	Power supply pump control, low-side or GPIO
69	PSSYNC	I/O	Power supply synchronization or GPIO
PWM PROTECTION PINS			
77, 80, 87, 90	PROTECTA[3:0]	I/O	PWM temperature status input, or GPIO
76, 79, 86, 89	PROTECTB[3:0]	I/O	PWM over current protection inputs, or GPIO
75, 78, 85, 88	PROTECTC[3:0]	I/O	PWM shoot-through current inputs or GPIO

Pin Definitions, 144 Ld LQFP Package (Continued)

PIN NUMBER	PORT NAME	TYPE	DESCRIPTION
POWER PINS			
119	PLLAVDD	Power	PLL analog power
118	PLLAGND	Ground	PLL analog ground
111	PLLDVDD	Power	PLL digital power
110	PLLDGND	Ground	PLL digital ground
114	OSCVDD	Power	Oscillator power
117	OSCGND	Ground	Oscillator ground
11, 27, 44, 59, 81, 91, 122, 136	CVDD	Power	Core power, eight pins
12, 28, 45, 60, 82, 92, 123, 137	CGND	Ground	Core ground, eight pins
96, 100, 104, 108	PWMVDD	Power	PWM output pin power, four pins
93, 97, 101, 105	PWMGND	Ground	PWM output pin ground, four pins
6, 30, 47, 63, 83, 128	RVDD	Power	Digital pad ring power, six pins
7, 31, 48, 64, 84, 129	RGND	Ground	Digital pad ring ground, six pins
NO CONNECT PINS			
70, 71, 73, 112, 113	NC		No connect, leave pin floating

Pin Descriptions, 144-Pin Package

Pins are 100% firmware and Reference Design Platform (RDP) package dependent for their functionality. Output pins have one of three drive strengths: 4mA, 8mA, or 16mA. These strengths are characterized by the current that the pin sources or sinks at the specified output voltage level.

SERIAL AUDIO INTERFACE (SAI) PINS

MCLK Master Clock Output

Master Clock output for external ADC/DAC components with 8mA drive strength. This pin drives low on reset. MCLK is also used by test hardware to monitor various internal clocks.

SCKR0 SAI Receiver Bit Clock 0

The SAI Receiver 0 bit clock is an output when the D2-1 Family is a master and is an input when the D2-1 Family is a slave. Defaults to an input on reset. Output has 4mA drive strength. Input has hysteresis.

LRCKR0 SAI Receiver Left/Right Clock 0

The SAI Receiver 0 left/right audio frame clock is an output when D2-1 Family is a master and is an input when the D2-1 Family is a slave. Defaults to an input on reset. Output has 4mA drive strength. Input has hysteresis.

SDIN0 SAI Receiver Serial Data Input 0

SAI Receiver 0 data input.

SCKR1 SAI Receiver Bit Clock 1

The SAI Receiver 1 bit clock is an output when the D2-1 Family is a master and is an input when the D2-1 Family is a slave. Defaults to an input on reset. Output has 4mA drive strength. Input has hysteresis.

LRCKR1 SAI Receiver Left/Right Clock 1

The SAI Receiver 1 left/right audio frame clock is an output when the D2-1 Family is a master and is an input when the D2-1 Family is a slave. Defaults to an input on reset. Output has 4mA drive strength. Input has hysteresis.

SDIN1 SAI Receiver Serial Data Input 1

SAI Receiver 1 data input.

SCKT SAI Transmitter Bit Clock

The SAI Transmitter bit clock is an output when the D2-1 Family is a master and is an input when the D2-1 Family is a slave. Defaults to an input on reset. Output has 4mA drive strength. SCKT is used to monitor the 3.3V brownout detector during the POR hardware test.

LRCKT SAI Transmitter Left/Right Clock

The SAI Transmitter left/right audio frame clock is an output when D2-1 Family is a master and is an input when the D2-1 Family is a slave. Defaults to an input on reset. Output has 4mA drive strength. LRCKT monitors the 1.8V brownout detector during the POR Hardware test. It also monitors PLL Lock during the PLL Hardware test.

SDOUT Serial Data Output

SAI Transmitter data output with 4mA drive strength. This pin drives low on reset.

S/PDIF PINS**SPDIFRX S/PDIF Data Input**

This pin is the S/PDIF audio input and accepts a 3.3V stereo input up to 192kHz. To drive this pin, appropriate buffer and/or isolation circuits may be necessary to convert the S/PDIF cable input signal to clean logic levels.

SPDIFTX S/PDIF Data Output

This pin is the S/PDIF audio output and drives a 3.3V stereo output up to 192kHz.

PWM PINS**PWMxH PWM High-Side Driver Outputs**

PWM high-side driver outputs, where x is 0 to 3, with 16mA drive strength. This pin drives to the state determined by OTSEL on reset.

PWMxL PWM Low-Side Driver Outputs

PWM low-side driver outputs, where x is 0 to 3, with 16mA drive strength. This pin drives low on reset.

OTSEL Output Topology Select Input

Output topology select input. The OTSEL pin state controls the PWMxH drive polarity. OTSEL is typically tied either high for active-low PWMxH FET drivers, or tied low for active-high PWMxH FET drivers.

PWMSYNC PWM Synchronization

PWM synchronization port with 4mA drive. Used in multi-D2-1 Family configurations to synchronize the PWM controllers. The master D2-1 Family drives synchronization data to the slave D2-1 Family(ies), so this pin is an output on the master D2-1 Family and an input on the slave D2-1 Family(ies). This pin floats on reset.

2-WIRE SERIAL PINS**SCL Serial Clock**

Two-Wire Serial clock port, open drain driver with 4mA drive strength. This bidirectional signal is used by both the master and slave controllers for clock signaling.

SDA Serial Data

Two-Wire Serial data port, open drain driver with 4mA drive strength. This bidirectional signal is used by both the master and slave controllers for data transport.

XGPIO PINS**XGPIO[15:0] Extended General Purpose I/O**

Bidirectional GPIO port with 4mA driver. Resets to the input port.

RESET AND TEST PINS**nRESET System Reset Input**

Active low reset input with hysteresis. A low level activates system level reset, which initializes all internal logic and program operations. The system latches the boot mode selection on the IRQ input pins on the rising edge.

nRSTOUT System Reset Output

Active low reset output with 4mA driver. This pin drives low on any POR output, 3.3V brownout detector, or 1.8V brownout detector.

TEST Test Mode Input

Hardware test mode control. For D2 Audio DSP usage only. Must be tied low.

nTRST Test Reset Input

Active low test port reset. A low level activates test reset, which initializes test hardware. Must be driven low with nRESET.

CRYSTAL OSCILLATOR AND PLL PINS**OSCOU Oscillator Output**

Analog oscillator output to slave D2-1 Family devices. On reset, OSCOUT drives a buffered version of the crystal oscillator signal from the XTALI pin. Can be turned off by program control.

XTALI Crystal Oscillator Input

Crystal oscillator analog input port. An external clock source is driven into the this port. In multi-D2-1 Family systems, the OSCOUT from the master D2-1 Family drives the XTALI pin.

XTALO Crystal Oscillator Output

Crystal oscillator analog output port. This pin must be open when using an external clock source.

GPIO PINS**GPIO[7:0] General Purpose I/O**

Bidirectional GPIO ports with 4mA driver. Resets to the input ports.

SYSTEM CONFIGURATION PINS**SYS0 System Configuration Data 0**

Reserved for factory test. Tie low with a 10kΩ resistor.

SYS1 System Configuration Data 1

Reserved for factory test. Tie high with a 10kΩ resistor.

SYS2 System Configuration Data 2

Reserved for factory test. Tie high with a 10kΩ resistor.

SYS3 System Configuration Data 3

Reserved for factory test. Tie high with a 10kΩ resistor.

SYS4 System Configuration Data 4

Reserved for factory test. Tie high with a 10kΩ resistor.

SERIAL COMMUNICATIONS INTERFACE (SCI) PINS**SCLK Serial Clock**

Serial communications clock with 4mA drive and hysteresis on input. Resets to the input port. Can be configured to GPIO.

RXD Receive Data

Serial communications receiver data with 4mA drive. Resets to the input port. Can be configured to GPIO.

TXD Transmit Data

Serial communications transmitter data with 4mA drive. Resets to the input port. Can be configured to GPIO.

OPTIONAL/RESERVED FUNCTION PINS**SCK0 Reserved Serial Audio Interface 0 Serial Clock**

Serial Audio Interface 0 serial clock port with 4mA driver and hysteresis receiver. Resets to the input port. Can be configured as GPIO.

SC00-SC02 Reserved Serial Audio Interface 0 Serial Control

Serial Audio Interface 0 serial control port with 4mA driver. Resets to the input port. Can be configured as GPIO.

STD0 Reserved Serial Audio Interface 0 Serial Transmit Data

Serial Audio Interface 0 serial transmit data port with 4mA driver. Resets to the input port. Can be configured as GPIO.

SRD0 Reserved Serial Audio Interface 0 Serial Receive Data

Serial Audio Interface 0 serial receive data port with 4mA driver. Resets to the input port. Can be configured as GPIO.

SCK1 Reserved Serial Audio Interface 1 Serial Clock

Serial Audio Interface 1 serial clock port with 4mA driver and hysteresis receiver. Resets to the input port. Can be configured as GPIO.

SC10-SC12 Reserved Serial Audio Interface 1 Serial Control

Serial Audio Interface 1 serial control port with 4mA driver. Resets to the input port. Can be configured as GPIO.

STD1 Reserved Serial Audio Interface 1 Serial Transmit Data

Serial Audio Interface 1 serial transmit data port with 4mA driver. Resets to the input port. Can be configured as GPIO.

SRD1 Reserved Serial Audio Interface 1 Serial Receive Data

Serial Audio Interface 1 serial receive data port with 4mA driver. Resets to the input port. Can be configured as GPIO.

BOOT MODE SELECT PINS**BMS[3:0] Boot Mode Select Inputs**

External boot mode select inputs. On nRESET deassertion, these pins provide the boot mode selection.

TIMER (TIO) PINS**TIO[2:0] Timer**

Timer I/O ports with 4mA driver. Can be configured as GPIO.

PUMPHI Power Supply Pump High

High-side power supply pump output with 16mA driver. Can be configured as GPIO. Drives low on reset. Provides control for operating an external switching power supply.

PUMPLO Power Supply Pump Low

Low-side power supply pump output with 16mA driver. Can be configured as GPIO. Drives low on reset. Provides control for operating an external switching power supply.

PSSYNC Power Supply Synchronization

Switching power supply synchronization signal with 16mA driver. Can be configured as GPIO. Resets to the input port.

PWM PROTECTION PINS**PROTECTA[3:0] PWM Temperature Protection Inputs**

PWM temperature protection inputs with hysteresis. Can be configured as GPIO. In this instance, the GPIO pins each have a 4mA driver. Each PWMTEMP input is associated with the corresponding PWM driver channel.

PROTECTB[3:0] PWM Overcurrent Protection Inputs

PWM overcurrent protection inputs with hysteresis. Can be configured as GPIO. In this instance, the GPIO pins each have a 4mA driver. Each PWMOCP input is associated with the corresponding PWM driver channel.

PROTECTC[3:0] PWM Shoot-Through Current Protection

PWM shoot-through-current protection inputs with hysteresis. Can be configured as GPIO. In this instance, the GPIO pins each have a 4mA driver. Each PWMSTC input is associated with the corresponding PWM driver channel.

POWER PINS**PLLAVDD/PLLAGND PLL Analog power and ground**

PLL analog supply/return. This 1.8V supply is used for the jitter critical sections of the PLL.

PLLDVDD/PLLDGND PLL Digital power and ground

PLL digital supply/return. This 1.8V supply is used for the “dirty” sections of the PLL and provides the pad supplies for all of the analog pads.

Note: PLLDGND and CGND are connected through the substrate.

OSCVDD/OSCGND Oscillator power and ground

Oscillator supply/return. This 1.8V supply is used for the crystal oscillator and oscillator bias circuits only.

CVDD/CGND Core power and ground

Core supply/return. This 1.8V supply is used in the chip interior logic and pad ring interfaces. Eight core supply pad pairs are internally connected around the pad ring.

PWMVDD/PWMGND PWM driver power and ground

PWM I/O pad driver supply/return. This 3.3V supply is used for the PWM pad drivers only. There are 4 PWM internally connected supply pairs, one for each PWM data channel.

RVDD/RGND Pad Ring power and ground

Ring I/O pad driver supply/return. This 3.3V supply is used for all the digital I/O pad drivers and receivers except for the PWM and analog pads. Six ring supply pairs are internally connected around the pad ring.

D2-1 Family Reset and Boot Modes

Reset

The D2-1 Family has a two reset inputs: the nRESET and nTRST input pins. The nRESET input pin is effectively a power-on system reset. All internal state logic, except internal test hardware, is initialized by nRESET. The system is held in the reset condition while reset is active. The reset conditions means all internal reset signals are active, the crystal oscillator is running, and the PLL is disabled. The nTRST input resets internal factory test hardware only.

To ensure proper system initialization, the nTRST input pin must be asserted along with nRESET.

TABLE 1. POWER-ON RESET TIMING DETAILS

SYMBOL	DESCRIPTION	MIN	TYP	MAX	UNIT
t-1.8Vgood	Valid 1.8V power before nRESET release	10			ns
t-3.3Vgood	Valid 3.3V power before nRESET release	10			ns
tBMSsu	Boot Mode Select (BMS[3:0]) setup	10			ns
tBMShd	Boot Mode Select (BMS[3:0]) hold	0			ns

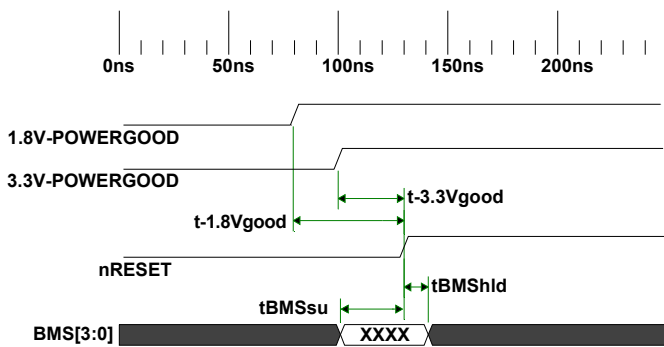

FIGURE 5. POWER-ON RESET TIMING

Boot Modes

The boot mode is determined by the BMS[3:0] pin inputs. The BMS[3:0] pin state is latched on the deassertion of system reset. The application board should have pull-ups in the BMS[3:0] pins so that the desired boot mode is selected by default. [Table 2](#) defines the boot modes.

TABLE 2. BOOT MODES

MODE	BMS[3:0]	M/S	INTERFACE SPEED	DESCRIPTION
0	0000			Reserved
1	0001	M	400kb/s	ROM on 2-wire 0 port
2	0010	S	384kb/s	Fast Asynchronous SCL slave boot (ex: D2-814xx to D2-814xx)
3	0011	S	per master	SPI slave
7	0111	M	384kb/s	2-wire ROM on GPIO port (SCL = GPIO7, SDA = GPIO6)
8	1000			Reserved
9	1001			Reserved
A	1010			Reserved
B	1011			Reserved
C	1100	S	per master	2-wire slave boot from micro, address = 1000100x
D	1101			Reserved
E	1110			Reserved
F	1111			Reserved

The Interface Speed specification is the speed at which the interface is configured to operate by the boot code. For the selection where the interface speed is “per Master”, the interface must operate within the requirements of the selected interface specification. For example, the EEPROM boot speed with 2-wire interface is 400kHz.

TABLE 3. EXTERNAL HOST BOOT TIMING DETAILS

SYMBOL	DESCRIPTION	MIN	TYP	MAX	UNIT
tBMSsu	Boot Mode Select (BMS[3:0]) setup	10			ns
tBMShd	Boot Mode Select (BMS[3:0]) hold	0			ns
tEXTbootRDY	2-Wire external source ready to boot	2400000			ns

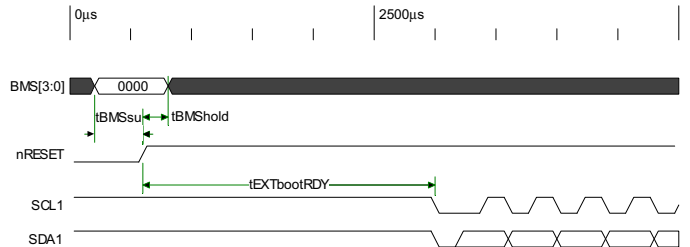

FIGURE 6. EXTERNAL HOST BOOT TIMING

TABLE 4. 2-WIRE EEPROM BOOT TIMING DETAILS

SYMBOL	DESCRIPTION	MIN	TYP	MAX	UNIT
tEEboot	2-Wire EE boot delay	2650000			ns
tBMSsu	Boot Mode Select (BMS[3:0]) setup	10			ns
tBMShd	Boot Mode Select (BMS[3:0]) hold	0			ns

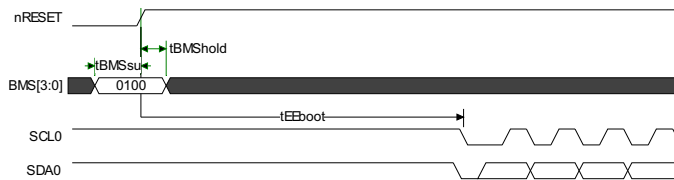

FIGURE 7. 2-WIRE EEPROM BOOT TIMING

Revision History The revision history provided is for informational purposes only and is believed to be accurate, but not warranted. Visit our website to make sure that you have the latest revision.

Rev	Date	Description
FN6786.3	Mar 18, 2019	<ul style="list-style-type: none"> -Changed name of datasheet to "D2-1 Family Audio SOC". -Changed references to "D2-814xx" to "D2-1 Family" throughout datasheet. -Changed all instances of "D2Audio™" to "D2 Audio DSP"; "DAE-1" to "D2-1 Family"; and "SoundSuite" to "Sound Enhancement Algorithms". Added Related Literature section. -Removed D2-81434 from datasheet. -Ordering Information table on page 2: <ul style="list-style-type: none"> Removed Notes 1, 2, and 3 and added Temp Range column For part number D2-81412-LR, added text "Not recommended for new designs. Recommended replacement: D2-81431-LR" -Changed θ_{JA} and θ_{JA} for both package types in Thermal Information section on page 5. -Changed "Intersil" to "Renesas" throughout datasheet, including in the Disclaimer for Dolby Technology License Required Notice on page 24. -Removed About Intersil section and added new disclaimer.
FN6786.2	May 18, 2016	<ul style="list-style-type: none"> Added Part number D2-81431 to datasheet Page 1 Features: Multiple Part Offerings updated descriptions, removed D2-81433 and D2-81434 from listing. Added D2-81431 Page 3 Ordering Information table: added D2-81431-LR, and updated D2-81433-LR and Ds-81434-LR (lifecycle status/recommended replacement). Thermal Information page 5, added notes for Theta JA and JC. Added Dolby and DTS (SRS) Disclaimers on page 24.
FN6786.1	Nov 24, 2015	<ul style="list-style-type: none"> -Updated the Ordering Information table on page 3. -Updated Package Outline Drawing (POD) Q144.20x20B to the latest revision. Changes from Rev. 0 to Rev. 1 are as follows: <ul style="list-style-type: none"> -Changed title from "Thin Plastic Quad Flatpack Package (LQFP)" to "Low Plastic Quad Flatpack Package (LQFP)" -Updated Package Outline Drawing (POD) Q128.14x14 to the latest revision. Changes from Rev. 0 to Rev. 1 are as follows: <ul style="list-style-type: none"> -Changed title from "Thin Plastic Quad Flatpack Package (LQFP)" to "Low Plastic Quad Flatpack Package (LQFP)"
FN6786.0	Mar 15, 2010	Converted to Intersil format. Assigned file number FN6786. Rev 0 - first release with this file number. Removed part numbering scheme and replaced available parts with ordering information table.
1.1.4	Oct 4, 2007	<ul style="list-style-type: none"> -Added new part numbers (D2-81434-LR and D2-81435-LR) on page 1 and pages 32, 33 -Revised part descriptions to include new part numbers
1.1.3	Nov 29, 2006	<ul style="list-style-type: none"> -Added [3:0] vector to Table 2, "BOOT MODES," on page 20 -Added timing details Table 1, "POWER-ON RESET TIMING DETAILS," on page 20, Table 3, "EXTERNAL HOST BOOT TIMING DETAILS," on page 20, Table 4, "2-WIRE EEPROM BOOT TIMING DETAILS," on page 21 -Added timing sequence figures Figure 5 on page 20, Figure 6 on page 20, Figure 7 on page 21
1.1.2	Jul 17, 2006	<ul style="list-style-type: none"> -Changed Core Supply Pins CVDD from 300 mA to 325 mA in Table 3, "POWER REQUIREMENTS," on page 6 -Updated Environment Category in Section , "IC Part Numbering Scheme," on page 25 -Swapped Theta J_A and J_C values for 128-pin and 144-pin LQFP packages in Table 4, "THERMAL CHARACTERISTICS," on page 6
1.1.1	Mar 27, 2006	Updated Theta J_A and J_C values for 128-pin and 144-pin LQFP packages in Table 4, "THERMAL CHARACTERISTICS," on page 6.
1.0.6	Feb 20, 2006	Added Junction Temperature to Table 1, "ABSOLUTE MAXIMUM RATINGS," on page 5 in addition to Note 1 on Operating Temperature, Storage Temperature and Storage Temperature. Added Table 4, "THERMAL CHARACTERISTICS," on page 6 which shows Theta J_A and J_C values for 128-pin and 144-pin LQFP packages.
1.0.5	Feb 8, 2006	Changed all related text, pin descriptions and pinout drawings for CTRL0, CTRL1, CTRL2, CTRL3. CTRL0 is now PUMPHI. CTRL1 is now PUMPLO. CTRL2 is now PSSYNC. CTRL3 is now PWMSYNC.

Revision History

The revision history provided is for informational purposes only and is believed to be accurate, but not warranted. Visit our website to make sure that you have the latest revision. **(Continued)**

Rev	Date	Description
1.0.4	Feb 7, 2006	Changed text on cover page regarding valid boot modes. Updated Figure 1 on page 4 to relabel the Serial Audio block to Serial Audio Interface block. Renamed Serial Audio Interface block to be Reserved Serial Audio Interface block. Updated text in Ordering Information on page 4. Changed "module" to "IC" in "Serial Audio Interface (SAI ports)" on page 6. Updated text in Table on page 8 to change "Serial Audio (SAI) Pins" to be "Serial Audio Interface (SAI) Pins". Updated text in Table on the following page to change "Serial Audio Interface Pins" to be "Reserved Serial Audio Interface Pins" in both header and pin description sections. Changed title in "Serial Audio Interface (SAI) Pins" on page 11 from "Serial Audio (SAI) Pins" to be "Serial Audio Interface (SAI) Pins". Changed SPDIF to S/PDIF in section "Serial Audio Interface (SAI) Pins" on page 11. Deleted "or nRESET active low" from "Reset and Test Pins" on page 12 and in "Reset and Test Pins" on page 18 from the nRSTOUT pin description. Changed the title in "Optional/Reserved Function Pins" on page 12 from "Optional Function Pins" to "Optional/Reserved Function Pins". Changed the pin descriptions in this section to now have a "Reserved" in front. Changed text in "PWM Protection Pins" on page 13 on all pin descriptions. Relabeled pin "SDO" to "SDOUT" in Figure 6 on page 14, in Table on page 14 as well as in "Serial Audio Interface (SAI) Pins" on page 17.
1.0.3	Jan 31, 2006	Changed 128-pin package pinouts on page 8, and Table on page 8.
1.0.2	Dec 22, 2005	Corrected cover page feature set descriptions, corrected Available Part Numbers in Ordering table.
1.0.1	Dec 6, 2005	Updated SYS0 pin from tie-high to tie-low.
1.0.0	Oct 20, 2005	Updated cover page, updated block diagram Serial Audio Interface, updated OTSEL pin description, added 2-Wire interface and Serial Audio Port sections, added firmware and reference design disclaimers, updated part numbers.
0.0.5	Sep 14, 2005	Updated all 128/144 package pinout tables and descriptions, removed waveforms, added block diagram, updated cover page.
0.0.4	Aug 17, 2005	Updated IC image on master pages, added Section 8.1 "0" performance option, renamed document, updated cover page
0.0.3	Aug 15, 2005	Updated pins in 128-pin/144-pin package drawings, eliminated signal flow diagram, added 2 part numbers.
0.0.2	Aug 12, 2005	Updated product features, included new drawings of 128-pin/144-pin package, included new 144-pin pinout and pin name descriptions.
0.0.1	Jul 25, 2005	Created new data sheet template, updated product features, included new drawings of 128-pin package, included new 128-pin pinout and pin name descriptions.

Trademarks

Audistry™ by Dolby, Dolby Headphone™, Dolby Pro Logic II, Dolby Pro Logic II/IIx™, Dolby Pro Logic II™, Dolby Virtual Speaker™, and Surround EX™ are trademarks of Dolby Laboratories Licensing Corporation. Audyssey 2EQ™, Audyssey EQ™, Audyssey MultEQ Pro™, Audyssey MultEQ XT™ and Audyssey MultEQ™ are trademarks of Audyssey Laboratories, Inc. BBE™ is a trademark of BBE Sound, Inc. DTS Neo:6™ is a trademark of Digital Theater Systems, Inc. Logic 7™ is a trademark of Harman International Industries, Incorporated. Microsoft™, Windows™ XP, Windows™ 2000 are trademarks of Microsoft Corporation. SRS Definition™, SRS Dialog Clarity™, SRS FOCUS™, SRS Headphone 360™, SRS TruBass™, SRS TruSurround HD™, SRS TruSurround HD4™, SRS TruSurround XT HD/HD4™, SRS TruSurround XT™, SRS TruSurround™, SRS WOW HD™ and SRS WOW™ are trademarks of SRS Laboratories, Inc. THX Adaptive De-Correlation™, THX Advanced Speaker Array (ASA)™, THX Bass Management with Bass Peak Limiter™, THX Boundary Gain Compensation (BGC)™, THX Cinema Re-EQ™, THX™ Ultra2™ and THX™ Select™ are trademarks of THX Ltd.

Disclaimer for Dolby Technology License Required Notice

Renesas may distribute Dolby™ technology separately from its D2 Audio DSP integrated circuits. Dolby™ technology would be embedded in firmware to be loaded onto and executed by Dolby™ enabled D2 Audio DSP integrated circuits. Supply of this implementation of Dolby technology does not convey a license nor imply a right under any patent or any other industrial or intellectual property right of Dolby Laboratories to use this implementation in any finished end-user or ready-to-use final product. It is hereby notified that a license for such use is required from Dolby Laboratories. In some cases the Dolby™ technology may include at least one Dolby™ Pro Logic™ decoder. The party receiving this implementation must be licensed for at least one of the three Dolby Laboratories Licensing Corporation ("Dolby") technologies contained in this implementation. If the party receiving this implementation is not a Licensee for all three of the Dolby technologies contained in this implementation then the party may only use the unlicensed technology(ies) contained on the implementation for internal testing and evaluation purposes.

Disclaimer for DTS (SRS) Technology License Required Notice

NOTICE OF LICENSE REQUIREMENT: Supply of this implementation of DTS technology to DTS Product Licensees directly or through a distributor does not incur a royalty payment or convey a license, exhaust DTS' rights in the implementation, or imply a right under any patent or any other industrial or intellectual property right of DTS to use, offer for sale, sell, or import such implementation in any finished end-user or ready-to-use final product. A license from and royalty payment to DTS is required prior to and for such use.

Package Outline Drawings

For the most recent package outline drawing, see [Q144.20x20B](#).

Q144.20x20B

144 Lead Low Plastic Quad Flatpack Package (LQFP)

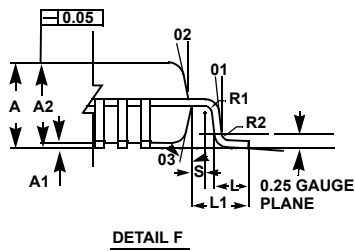
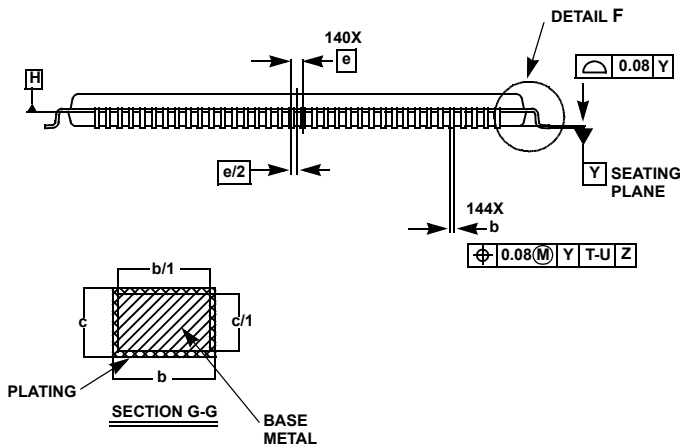
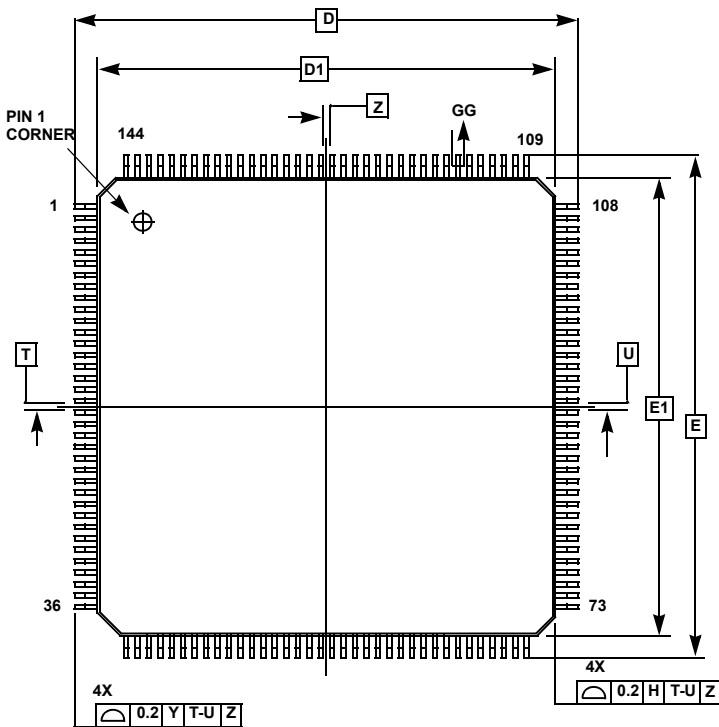

SYMBOL	MILLIMETERS			NOTES
	MIN	NOM	MAX	
A	-	-	1.60	
A1	0.05	-	0.15	
A2	1.35	1.40	1.45	
b	0.17	0.22	0.27	13
b1	0.17	0.20	0.23	
c	0.09	-	0.20	
c1	0.09	-	0.16	
D	22 BSC			
D1	20 BSC			12
E	22 BSC			
E1	20 BSC			12
L	0.45	0.60	0.75	
L1	1.00 REF			
R1	0.08	-	-	
R2	0.08	-	0.20	
S	0.20	-	-	
θ	0°	3.5°	7.0°	
θ1	0°	-	-	
θ2	11°	12°	13°	
θ3	11°	12°	13°	
N	128			5
e	0.50 BSC			

Rev. 1 7/11

NOTES:

- Dimensions are in millimeters. Dimensions in () for Reference Only.
- Dimensioning and tolerancing conform to AMSE Y14.5m-1994.
- Dimensions D1 and E1 are excluding mold protrusion. Allowable protrusion is 0.25mm per side. Dimensions D1 and E1 are inclusive of mold mismatch and determined by datum plane H.
- Dimension b does not include dambar protrusion. Allowable dambar protrusion shall not cause the lead width to exceed the maximum b dimension by more than 0.08mm. Dambar cannot be located at the lower radius or the foot. Minimum space between protrusion and an adjacent lead is 0.07mm.
- N is total number of the lead terminals.

Q128.14x14
128 LEAD LOW PLASTIC QUAD FLATPACK PACKAGE .4 MM PITCH (LQFP)

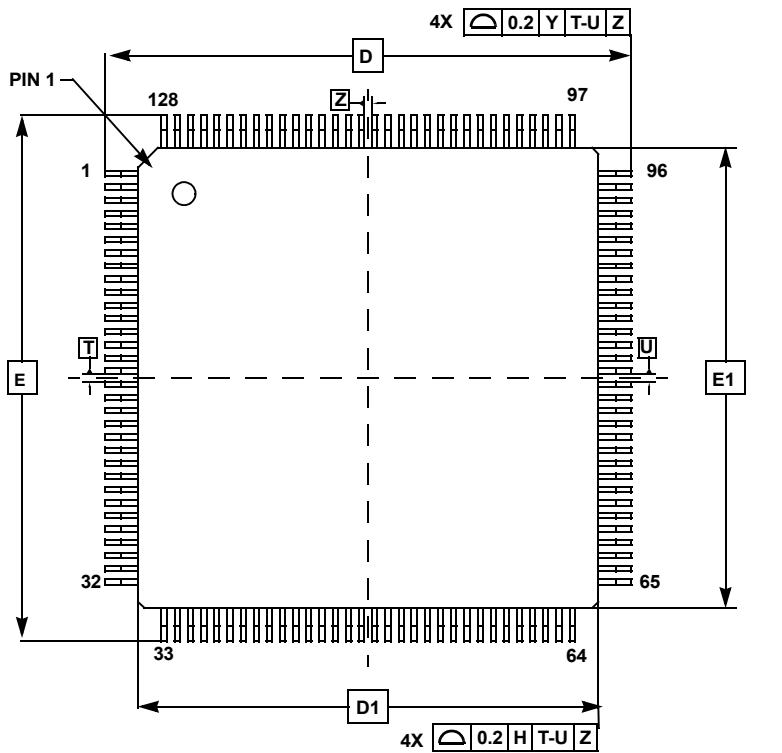

SYMBOL	MILLIMETERS			NOTES
	MIN	NOM	MAX	
A	-		1.60	-
A1	0.05		0.15	-
A2	1.35	1.40	1.45	-
b	0.13	0.16	0.23	4
b1	0.13	-	0.19	-
c	0.09	-	0.20	-
c1	0.09	-	0.16	-
D	16 BSC			-
D1	14 BSC			3
E	16 BSC			-
E1	14 BSC			3
L	0.45	0.60	0.75	-
L1	1.00 REF			-
R1	0.08	-	-	-
R2	0.08	-	0.20	-
S	0.20	-	-	-
0	0°	3.5°	7°	-
01	0°	-	-	-
02	11°	12°	13°	-
03	11°	12°	13°	-
N	128			-
e	0.40 BSC			-

Rev. 1 7/11

NOTES:

- Dimensions are in millimeters. Dimensions in () for Reference Only.
- Dimensions and tolerances per AMSEY14.5M-1994.
- Dimensions D1 and E1 are excluding mold protrusion. Allowable protrusion is 0.25 per side. Dimensions D1 and E1 are exclusive of mold mismatch and determined by datum plane H.
- Dimension b does not include dambar protrusion. Allowable dambar protrusion shall not cause the lead width to exceed the maximum b dimension by more than 0.08mm. Dambar cannot be located at the lower radius or the foot. Minimum space between protrusion and an adjacent lead is 0.07 mm.

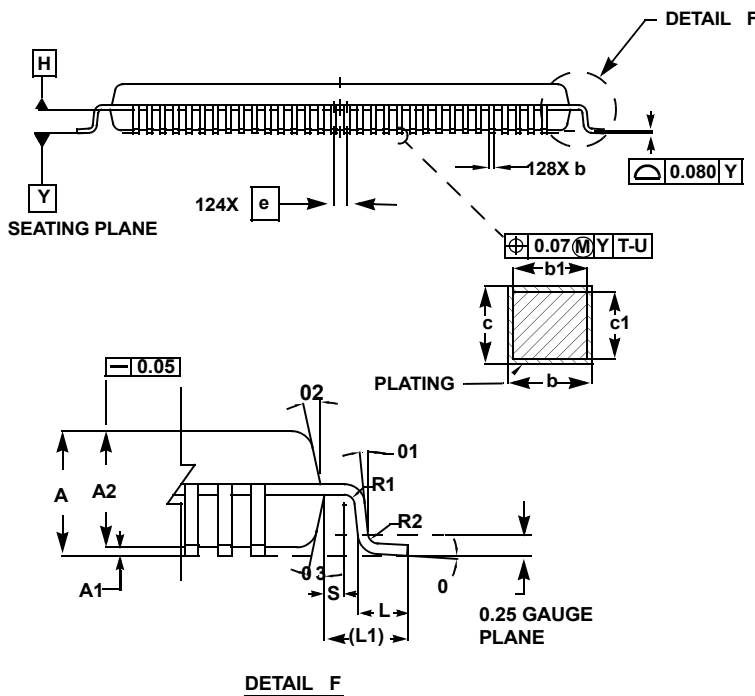

Notice

1. Descriptions of circuits, software and other related information in this document are provided only to illustrate the operation of semiconductor products and application examples. You are fully responsible for the incorporation or any other use of the circuits, software, and information in the design of your product or system. Renesas Electronics disclaims any and all liability for any losses and damages incurred by you or third parties arising from the use of these circuits, software, or information.
 2. Renesas Electronics hereby expressly disclaims any warranties against and liability for infringement or any other claims involving patents, copyrights, or other intellectual property rights of third parties, by or arising from the use of Renesas Electronics products or technical information described in this document, including but not limited to, the product data, drawings, charts, programs, algorithms, and application examples.
 3. No license, express, implied or otherwise, is granted hereby under any patents, copyrights or other intellectual property rights of Renesas Electronics or others.
 4. You shall not alter, modify, copy, or reverse engineer any Renesas Electronics product, whether in whole or in part. Renesas Electronics disclaims any and all liability for any losses or damages incurred by you or third parties arising from such alteration, modification, copying or reverse engineering.
 5. Renesas Electronics products are classified according to the following two quality grades: "Standard" and "High Quality". The intended applications for each Renesas Electronics product depends on the product's quality grade, as indicated below.
 - "Standard": Computers; office equipment; communications equipment; test and measurement equipment; audio and visual equipment; home electronic appliances; machine tools; personal electronic equipment; industrial robots; etc.
 - "High Quality": Transportation equipment (automobiles, trains, ships, etc.); traffic control (traffic lights); large-scale communication equipment; key financial terminal systems; safety control equipment; etc.Unless expressly designated as a high reliability product or a product for harsh environments in a Renesas Electronics data sheet or other Renesas Electronics document, Renesas Electronics products are not intended or authorized for use in products or systems that may pose a direct threat to human life or bodily injury (artificial life support devices or systems; surgical implantations; etc.), or may cause serious property damage (space system; undersea repeaters; nuclear power control systems; aircraft control systems; key plant systems; military equipment; etc.). Renesas Electronics disclaims any and all liability for any damages or losses incurred by you or any third parties arising from the use of any Renesas Electronics product that is inconsistent with any Renesas Electronics data sheet, user's manual or other Renesas Electronics document.
 6. When using Renesas Electronics products, refer to the latest product information (data sheets, user's manuals, application notes, "General Notes for Handling and Using Semiconductor Devices" in the reliability handbook, etc.), and ensure that usage conditions are within the ranges specified by Renesas Electronics with respect to maximum ratings, operating power supply voltage range, heat dissipation characteristics, installation, etc. Renesas Electronics disclaims any and all liability for any malfunctions, failure or accident arising out of the use of Renesas Electronics products outside of such specified ranges.
 7. Although Renesas Electronics endeavors to improve the quality and reliability of Renesas Electronics products, semiconductor products have specific characteristics, such as the occurrence of failure at a certain rate and malfunctions under certain use conditions. Unless designated as a high reliability product or a product for harsh environments in a Renesas Electronics data sheet or other Renesas Electronics document, Renesas Electronics products are not subject to radiation resistance design. You are responsible for implementing safety measures to guard against the possibility of bodily injury, injury or damage caused by fire, and/or danger to the public in the event of a failure or malfunction of Renesas Electronics products, such as safety design for hardware and software, including but not limited to redundancy, fire control and malfunction prevention, appropriate treatment for aging degradation or any other appropriate measures. Because the evaluation of microcomputer software alone is very difficult and impractical, you are responsible for evaluating the safety of the final products or systems manufactured by you.
 8. Please contact a Renesas Electronics sales office for details as to environmental matters such as the environmental compatibility of each Renesas Electronics product. You are responsible for carefully and sufficiently investigating applicable laws and regulations that regulate the inclusion or use of controlled substances, including without limitation, the EU RoHS Directive, and using Renesas Electronics products in compliance with all these applicable laws and regulations. Renesas Electronics disclaims any and all liability for damages or losses occurring as a result of your noncompliance with applicable laws and regulations.
 9. Renesas Electronics products and technologies shall not be used for or incorporated into any products or systems whose manufacture, use, or sale is prohibited under any applicable domestic or foreign laws or regulations. You shall comply with any applicable export control laws and regulations promulgated and administered by the governments of any countries asserting jurisdiction over the parties or transactions.
 10. It is the responsibility of the buyer or distributor of Renesas Electronics products, or any other party who distributes, disposes of, or otherwise sells or transfers the product to a third party, to notify such third party in advance of the contents and conditions set forth in this document.
 11. This document shall not be reprinted, reproduced or duplicated in any form, in whole or in part, without prior written consent of Renesas Electronics.
 12. Please contact a Renesas Electronics sales office if you have any questions regarding the information contained in this document or Renesas Electronics products.
- (Note1) "Renesas Electronics" as used in this document means Renesas Electronics Corporation and also includes its directly or indirectly controlled subsidiaries.
- (Note2) "Renesas Electronics product(s)" means any product developed or manufactured by or for Renesas Electronics.

(Rev.4.0-1 November 2017)

Corporate Headquarters

TOYOSU FORESIA, 3-2-24 Toyosu,
Koto-ku, Tokyo 135-0061, Japan
www.renesas.com

Contact Information

For further information on a product, technology, the most up-to-date version of a document, or your nearest sales office, please visit:
www.renesas.com/contact/

Trademarks

Renesas and the Renesas logo are trademarks of Renesas Electronics Corporation. All trademarks and registered trademarks are the property of their respective owners.

X-ON Electronics

Largest Supplier of Electrical and Electronic Components

Click to view similar products for [Audio DSPs](#) category:

Click to view products by [Renesas](#) manufacturer:

Other Similar products are found below :

[AT85C51SND3B1-RTTUL](#) [BR281W31A101V1G](#) [CS47048C-CQZR](#) [MAX9892ERT+T](#) [SB3231-E1](#) [HMC1022-SX](#) [SA3229-E1-T](#)
[LC75056PE-H](#) [IA8201-RDI-01](#) [R3710-CEAA-E1](#) [HMC5622LS7TR](#) [TAS3204PAGR](#) [LC823450TA-2H](#) [LC823450XDTBG](#) [ZL38052LDG1](#)
[ADAU1452WBCPZ-RL](#) [ADAV4601BSTZ](#) [AD1954YSTZ](#) [ADAU1701JSTZ-RL](#) [AD1940YSTZ](#) [ADAU1701JSTZ](#) [ADAU1702JSTZ](#)
[ADAU1401AWBSTZ-RL](#) [PT2399](#) [XD567](#) [XD1881](#) [LM4863G-N20-R](#) [IA8201CQ](#) [SPK2611HM7H-1-2](#) [CM108B](#) [CM118B](#) [HS-100B](#)
[CM108AH](#) [CMX823E4](#) [S1V30120F01A100](#) [CMX138AE1](#) [MAX9892ELTT](#) [LC786820E-6E03-3H](#) [DSPB56720AG](#) [LC823455XATBG](#)
[XFS3031CNP](#) [ZL38060LDG1](#) [BD37033FV-ME2](#) [BM28720MUV-E2](#) [WT588H-16S](#) [WT588S-16S](#) [WT588D-20SS](#) [BD3702FV-E2](#)
[TEA1062NG-S16-R](#) [TM2313](#)