

## Description

The 5X1503 is a series of small form factor programmable clock generators intended for low-power, consumer, battery powered applications, wearable and smart devices.

The device is a 1 PLL + DCO architecture design with one embedded crystal. The device is OTP programmable, allowing for up to 3 unique frequency outputs. The 5X1503 has built-in unique features such as Proactive Power Saving (PPS) and a low power DCO to support system date/time keeping clock at 32.768kHz. Dynamic Frequency Control (DFC) supports dynamically changing between four different PLL frequencies via external requests with controlled frequency changes, reducing frequency overshoot and undershoot (ORT). The 5X1503S device can also support a spread clock for EMI reduction. For a description of terms and their functions, see [Glossary of Features](#).

An internal OTP memory allows the user to store up to four independent configurations that can be loaded on power-up without programming. It can then be reprogrammed again through the I<sup>2</sup>C interface.

The 5X1503 supports three LVCMOS type outputs. Two outputs have programmable amplitude. A low-power 32.768kHz clock is supported with only less than 1.5μA current consumption for system RTC reference clock needs.

| 5X1503 Base Number | Description                         | VCO Range (MHz) |
|--------------------|-------------------------------------|-----------------|
| 5X1503             | Standard, Integrated Crystal        | 50 – 130        |
| 5X1503L            | Ultra Low-power, Integrated Crystal | 50 – 130        |
| 5X1503S            | Spread Clock, Integrated Crystal    | 500 – 1100      |

## Typical Applications

- SmartDevice
- Handheld
- Wearable applications
- Portable Consumer applications

## Features

- Proactive Power Saving (PPS) features save power during the end device power-down mode
- Dynamic Frequency Control (DFC) feature allows programming up to 4 difference frequencies that switch dynamically
- Programmable output clock amplitude (1V, 1.1V, 1.2V and 1.8V) to support low swing clock requirement
- Dedicated 32kHz output with 6 clock amplitude options (5X1503L)
- Integrated crystal; no external input source requirement
- Configurable through I2C or OTP programming
- Spread spectrum clock support (5X1503S)
- 1.8V operating supply voltage
- 2 × 2 mm 10-VFQFPN package

## Output Features

- 3 LVCMOS outputs, 1MHz–100MHz or 32.768kHz
- Low-power 32.768kHz clock supported

## Key Specifications

- Output cycle-cycle jitter: 50ps (typ)
- Low power-on fully active mode: 2mA (typ)
- Low-power 32.768kHz < 1.0μA (5X1503L)

# Contents

|   |    |
|---|----|
| Description .....                               | 1  |
| Typical Applications .....                      | 1  |
| Features .....                                  | 1  |
| Output Features .....                           | 1  |
| Key Specifications .....                        | 1  |
| Block Diagram .....                             | 3  |
| Pin Assignments .....                           | 3  |
| Pin Descriptions .....                          | 4  |
| Device Feature and Function .....               | 4  |
| DFC – Dynamic Frequency Control .....           | 4  |
| DFC Function Programming .....                  | 5  |
| PPS – Proactive Power Saving Function .....     | 5  |
| PPS Function Programming .....                  | 6  |
| Output Divider Selection .....                  | 6  |
| Device Output Support .....                     | 7  |
| 5X1503 .....                                    | 7  |
| 5X1503L .....                                   | 7  |
| 5X1503S .....                                   | 7  |
| Input Pin Function .....                        | 7  |
| Spread Spectrum .....                           | 9  |
| Spread Spectrum .....                           | 9  |
| Digital Spread Spectrum .....                   | 9  |
| Absolute Maximum Ratings .....                  | 10 |
| Thermal Characteristics .....                   | 10 |
| Recommended Operating Conditions .....          | 10 |
| Crystal Characteristics .....                   | 11 |
| DC Electrical Characteristics .....             | 11 |
| AC Electrical Characteristics .....             | 12 |
| I2C Bus DC Characteristics .....                | 14 |
| Spread Spectrum Generation Specifications ..... | 15 |
| General I2C Interface Information .....         | 16 |
| How to Write .....                              | 16 |
| How to Read .....                               | 16 |
| Glossary of Features .....                      | 26 |
| Package Outline Drawings .....                  | 27 |
| Ordering Information .....                      | 27 |
| Marking Diagrams .....                          | 27 |
| Revision History .....                          | 28 |

## Block Diagram

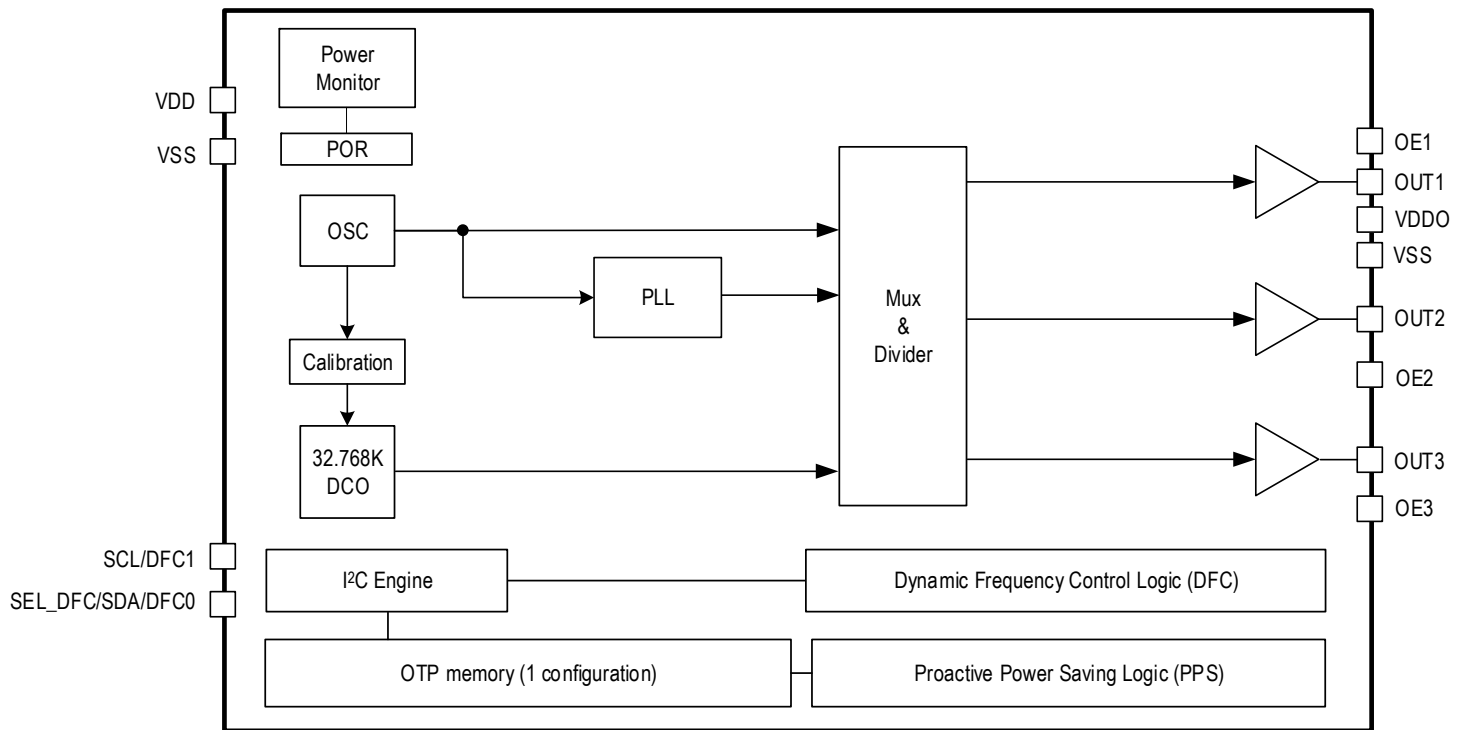

## Pin Assignments

Figure 1. Pin Assignments for 2.0 × 2.0 mm 10-VFQFPN Package

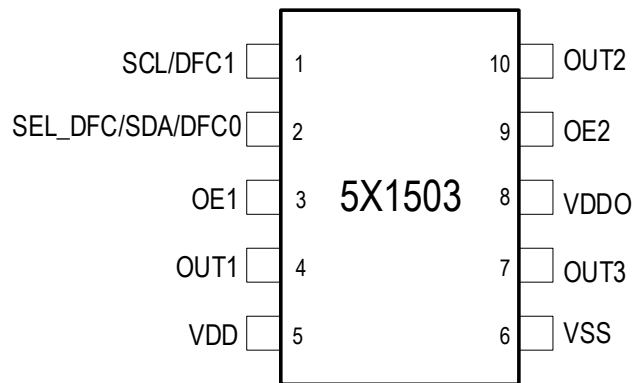

## Pin Descriptions

Table 1. Pin Descriptions

| Number | Name              | Type   | Description  |
|--------|-------------------|--------|--|
| 1      | SCL/DFC1          | Input  | I2C clock pin/dynamic frequency input pin.   |
| 2      | SEL_DFC /SDA/DFC0 | I/O    | Functional selection pin/I2C data pin/dynamic frequency input pin.<br>0 = HW mode; 0 = I2C mode. |
| 3      | OE1               | Input  | OUT1 output enable pin. The pin can be configured to other functions (DFC and PPS).              |
| 4      | OUT1              | Output | Programmable LVCMOS clock output (32.768kHz only on 5X1503L).                                    |
| 5      | VDD               | Power  | 1.8V power supply for core, PLL, and 32kHz DCO.  |
| 6      | VSS               | GND    | Connect to ground.   |
| 7      | OUT3              | Output | Programmable LVCMOS clock output.  |
| 8      | VDDO              | Power  | 1.8V power supply for I/O.   |
| 9      | OE2               | Input  | OUT2 output enable pin. The pin can be configured to other functions (DFC and PPS).              |
| 10     | OUT2              | Output | Programmable LVCMOS clock output.  |

## Device Feature and Function

### DFC – Dynamic Frequency Control

- OTP programmable—4 different feedback fractional dividers (4 VCO frequencies) that apply to PLL.
- ORT (overshoot reduction) function will be applied automatically during the VCO frequency change.
- Smooth frequency incremental or decremental from current VCO to targeted VCO based on DFC hardware pins selection.

Figure 2. DFC Function Block Diagram

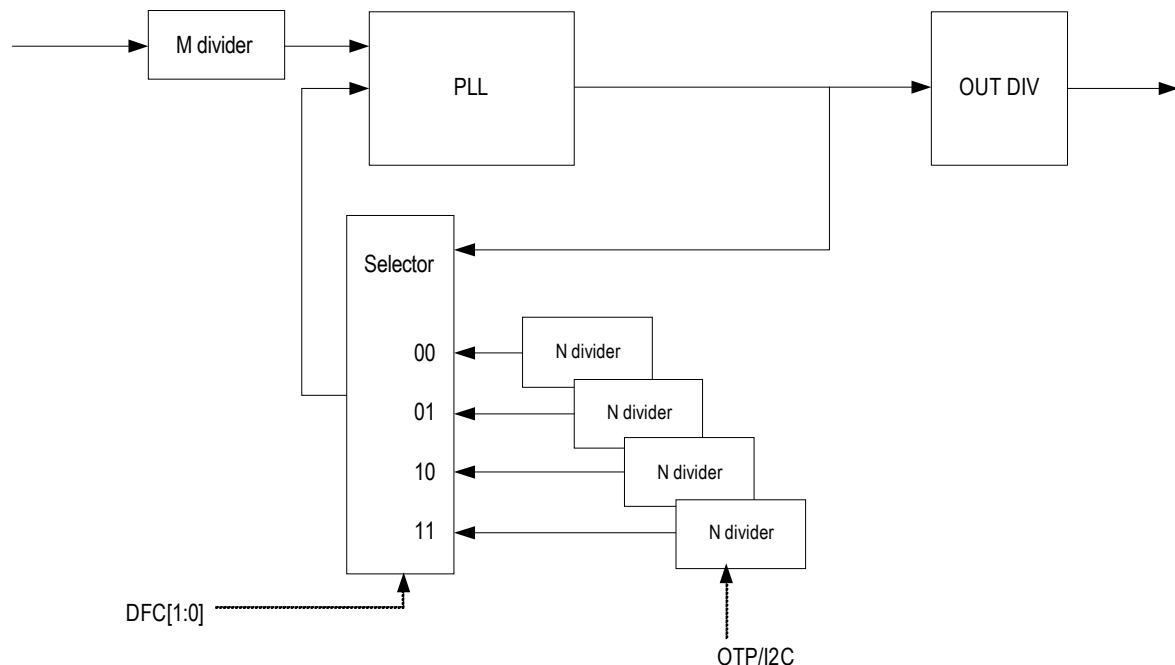

Table 2. DFC Function Priority

| Mode | DFC_EN B17[0] | I2C Read/Write | SDA_DFC0 Latch | SCL_HW_Mode_sel B18[5] | OE1_fun_sel B16[6:5] | OE2_fun_sel B16[3:2] | DFC1  | DFC1  | Notes                 |
|------|---------------|----------------|----------------|------------------------|----------------------|----------------------|-------|-------|-----------------------|
| x    | 0             | Yes            | x              | x                      | x                    | x                    | x     | x     | DFC disable           |
| SW   | 1             | Yes            | 1              | 0                      | 00–10                | 00 or 10             | B0[1] | B0[0] | Select via I2C        |
| HW   | 1             | No             | 0              | 1                      | 11                   | 00–10                | SCL   | OE1   | Select via pins       |
| HW   | 1             | No             | 0              | 1                      | 00–10                | 00–10                | SCL   | SDA   | Select via pins       |
| HW   | 1             | No             | 0              | 1                      | 11                   | 11                   | OE2   | OE1   | Select via pins       |
| HW   | 1             | No             | 0              | 1                      | 11                   | 01                   | —     | OE1   | Select via single pin |

## DFC Function Programming

- Register B0b1:0 – select DFC00–DFC11 configuration.
- Byte5–8 are the registers for PLL VCO setting. Based on B0b1:0 configuration selection, the data write to B5–8 will be stored in selected configuration OTP memory.
- Refer to [DFC Function Priority](#) table. Select proper control pin(s) to activate DFC function.
- Note the DFC function can also be controlled by I2C access.

## PPS – Proactive Power Saving Function

PPS (Proactive Power Saving) is an IDT patented unique design for the clock generator that proactively detects end device power down state and then switches output clocks between normal operation clock frequency and low power mode 32kHz clock that only consumes < 1.5µA current. The system could save power when the device goes into power down or sleep mode. The PPS function diagram is shown as below.

Figure 3. PPS Function Block Diagram

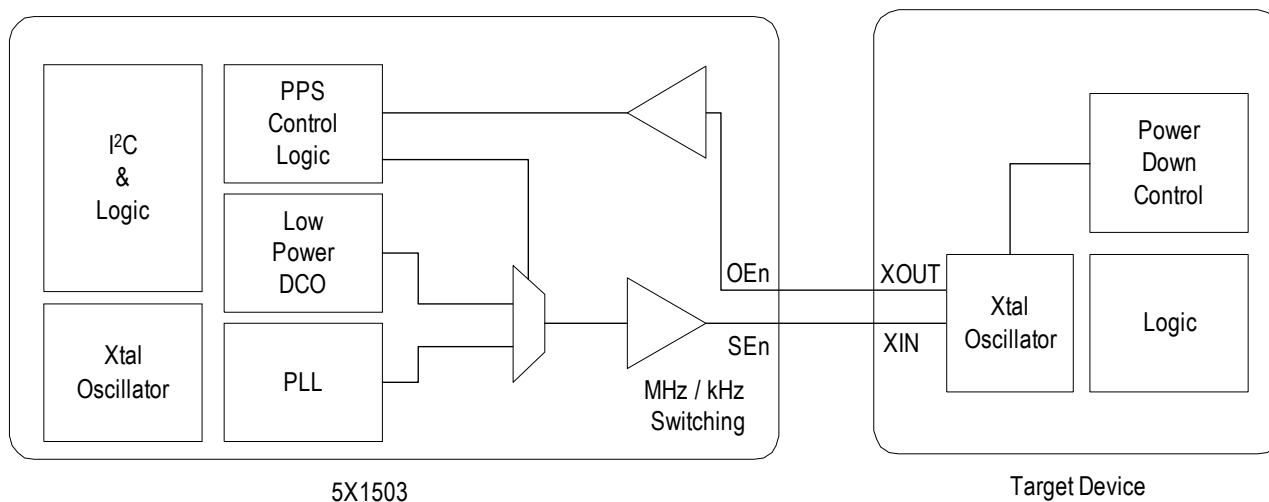
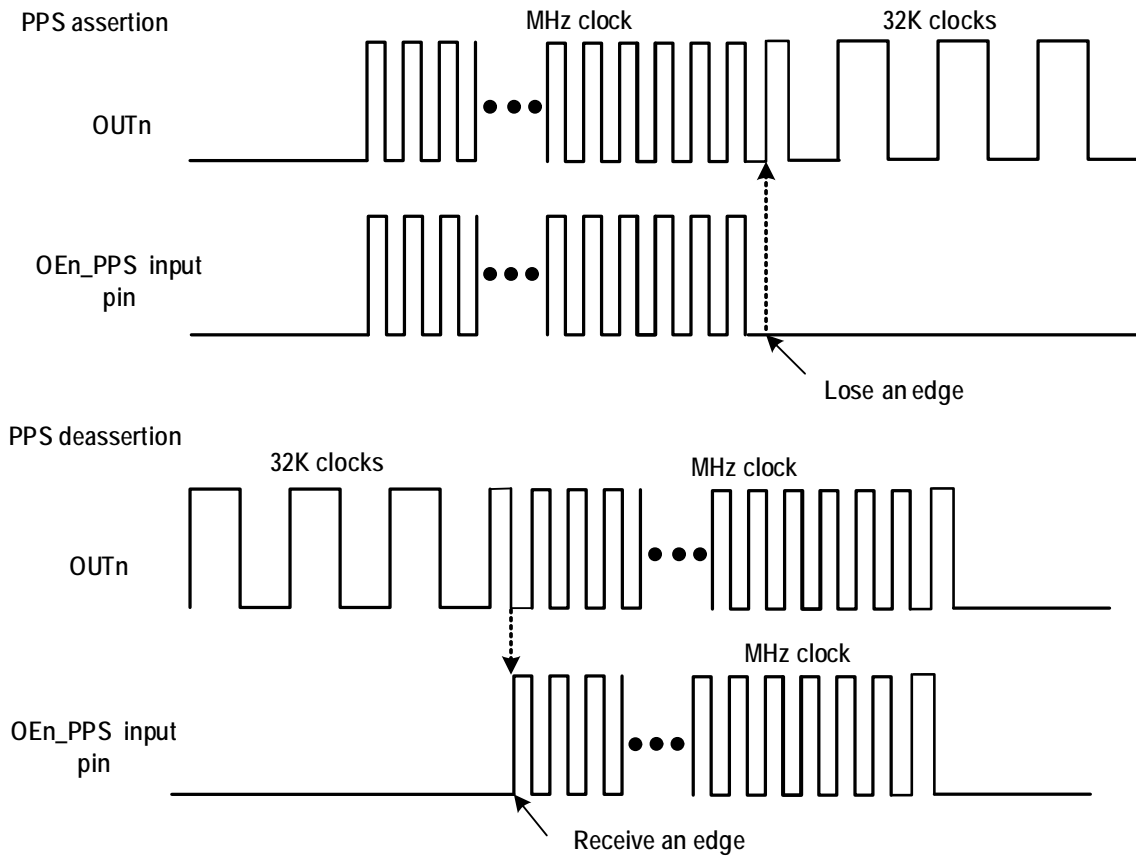

Figure 4. PPS Assertion/Deassertion Timing Chart



### PPS Function Programming

- Refer to the [OE Pin Function](#) table to have proper PPS function selected for OE pin(s). Note that the register default is set to Output Enable (OE) function for OE pins.
- Have proper setup to Byte 16 for OE1–OE2 function selection. For PPS function, select 10 to control register bits.

### Output Divider Selection

Table 3. Output Divider Selection

| Output Divider bits<4:3> | Output Divider bits<2:0> |     |     |     |     |     |
|--------------------------|--------------------------|-----|-----|-----|-----|-----|
|                          | 000                      | 001 | 010 | 011 | 100 | 101 |
| 00                       | 1                        | 3   | 5   | 7   | 9   | 11  |
| 01                       | 2                        | 6   | 10  | 14  | 18  | 22  |
| 10                       | 4                        | 12  | 20  | 28  | 36  | 44  |
| 11                       | 8                        | 24  | 40  | 56  | 72  | 88  |

## Device Output Support

### 5X1503

| Outputs | Frequency                    | Amplitude            | VCO Range      | Spread Spectrum |
|---------|------------------------------|----------------------|----------------|-----------------|
| OUT1    | 32kHz or up to 100MHz LVCMOS | 1.8V                 | 50MHz – 130MHz | N/A             |
| OUT2    |                              | 1V, 1.1V, 1.2V, 1.8V |                |                 |
| OUT3    |                              |                      |                |                 |

### 5X1503L

| Outputs | Frequency                    | Amplitude                        | VCO Range      | Spread Spectrum |
|---------|------------------------------|----------------------------------|----------------|-----------------|
| OUT1    | 32kHz                        | 0.8V, 0.9V, 1V, 1.1V, 1.2V, 1.8V | 50MHz – 130MHz | N/A             |
| OUT2    | 32kHz or up to 100MHz LVCMOS | 1V, 1.1V, 1.2V, 1.8V             |                |                 |
| OUT3    |                              |                                  |                |                 |

### 5X1503S

| Outputs | Frequency                    | Amplitude            | VCO Range        | Spread Spectrum |
|---------|------------------------------|----------------------|------------------|-----------------|
| OUT1    | 32kHz or up to 100MHz LVCMOS | 1.8V                 | 500MHz – 1100MHz | Available       |
| OUT2    |                              | 1V, 1.1V, 1.2V, 1.8V |                  |                 |
| OUT3    |                              |                      |                  |                 |

## Input Pin Function

OE pins in the 5X1503 have multiple functions. The OE pins can be configured as output enable control (OE) or chip power-down control (PD#) or Proactive Power Saving function (PPS). Furthermore, the OE1 pin can be configured as single or Dynamic Frequency Control (DFC).

Table 4. OE Pin Function

| Function                     | OE1      |                | OE2      |                |
|------------------------------|----------|----------------|----------|----------------|
|                              | B16<6:5> | Function       | B16<3:2> | Function       |
| Output Enable/Disable        | 00       | OUT1 (Default) | 00       | OUT2 (Default) |
| Global Power Down (PD#)      | 01       | PD#            | 01       | Config_SEL     |
| Proactive Power Saving Input | 10       | OUT1_PPS       | 10       | OUT2_PPS       |
| DFC Control                  | 11       | DFC0           | 11       | DFC1           |

Note: Config\_SEL and DFC Control require the device to be in H/W mode with no I2C access

Table 5. OE Pin Function Summary

| Pin           | Function   |
|---------------|--|
| OE1: OUT1     | OE1 only control OUT1 enable/disable, other outputs are not affected by this pin status.   |
| OE2: OUT2     | OE2 only control OUT2 enable/disable, other outputs are not affected by this pin status.   |
| OE1: PD#      | OE1 control chip global power down (PD#) except 32.768kHz on OE1 (when 32K is enabled), When the PD# pin is active low, the chip goes to lowest power down mode and all outputs are disabled except 32kHz output and only keep 32k/Xtal calibration. |
| OE1: OUT1_PPS | Config OE1 as OUT1_PPS (Proactive Power Saving) function pin.  |
| OE2: OUT2_PPS | Config OE2 as OUT2_PPS (Proactive Power Saving) function pin.  |
| OE1:DFC0      | Config OE1 as DFC0 control pin 0.  |
| OE2:DFC1      | Config OE2 as DFC1 control pin 1.  |

Table 6. PD# Priority

| PD# | I2C_OE_EN_bit | OUT1/2/3,<br>OUTx_PPS | Output  | Notes          |
|-----|---------------|-----------------------|---------|----------------|
| 0   | X             | X                     | stop    | 32KHz free run |
| 1   | 0             | X                     | stop    |                |
| 1   | 1             | 0                     | stop    |                |
| 1   | 1             | 1                     | running |                |



# Spread Spectrum

## Spread Spectrum

The 5X1503 supports spread spectrum clocks from PLL with digital spread spectrum.

## Digital Spread Spectrum

Figure 5. Digital Spread Spectrum

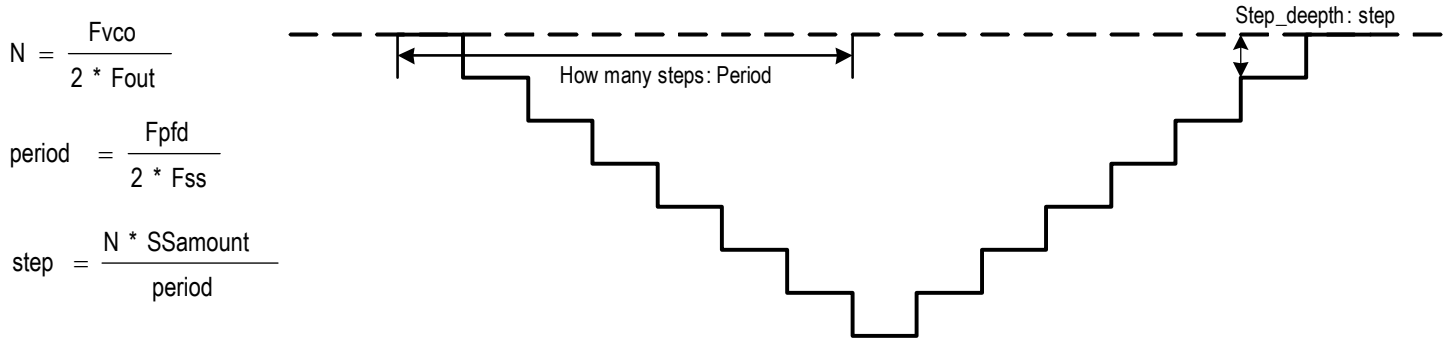

### Down spread or spread off

$$N = F_{vco}/F_{pfd}$$

N: include integer and fraction

Fvco: VCOs frequency

Fpfd: PLLs pfd frequency

Fss: spread modulation rate

SSamount: spread percentage

N will decrease to make the center frequency lower than spread off.

Example: 0.5% down spread at 32kHz modulation rate.

## Absolute Maximum Ratings

Stresses above the ratings listed below can cause permanent damage to the 5X1503. These ratings, which are standard values for IDT commercially rated parts, are stress ratings only. Functional operation of the device at these or any other conditions above those indicated in the operational sections of the specifications is not implied. Exposure to absolute maximum rating conditions for extended periods can affect product reliability. Electrical parameters are guaranteed only over the recommended operating temperature range.

Table 7. Absolute Maximum Ratings

| Item                                 | Rating                           |
|--------------------------------------|----------------------------------|
| Supply Voltage: $V_{DD}$ , $V_{DDO}$ | -0.5V to 2.2V                    |
| Inputs: DFC, OE1, OE2, SCL           | -0.5V to $V_{DD}/V_{DDO}$        |
| Outputs: LVCMOS                      | -0.5V to $V_{DD}/V_{DDO} + 0.5V$ |
| Outputs: SDA                         | 10mA                             |
| Storage Temperature, $T_{STG}$       | -65°C to 150°C                   |
| ESD Human Body Model                 | 2000V                            |
| Junction Temperature                 | 125°C                            |

## Thermal Characteristics

Table 8. Thermal Characteristics

| Symbol        | Parameter                                   | Value | Units |
|---------------|---|-------|-------|
| $\theta_{Jb}$ | Theta $J_B$ . Junction to board             | 28.4  | °C/W  |
| $\theta_{Jc}$ | Theta $J_C$ . Junction to case              | 183.3 | °C/W  |
|               | Moisture Sensitivity Rating (per J-STD-020) | MSL1  | —     |

## Recommended Operating Conditions

Table 9. Recommended Operating Conditions

| Symbol          | Parameter  | Minimum | Typical | Maximum | Units |
|-----------------|--|---------|---------|---------|-------|
| $V_{DDOUT1}$    | Power Supply Voltage for Supporting OUT1   | 1.71    | 1.8     | 1.89    | V     |
| $V_{DDOUT2}$    | Power Supply Voltage for Supporting OUT2/OUT3  | 1.71    | 1.8     | 1.89    | V     |
| $V_{DD1\_8}$    | Power Supply Voltage for Core Logic Functions  | 1.71    | 1.8     | 1.89    | V     |
| $T_A$           | Ambient Operating Temperature  | -40     | —       | 85      | °C    |
| $C_{LOAD\_OUT}$ | Maximum Load Capacitance (1.8V LVCMOS only)  | —       | 5       | —       | pF    |
| $t_{PU}$        | Power-up Time for all $V_{DDs}$ to reach Minimum Specified Voltage (power ramps must be monotonic) | 0.05    | —       | 3       | ms    |

## Crystal Characteristics

Table 10. Embedded Crystal Characteristics

| Parameter                          | Test Conditions | Minimum     | Typical | Maximum | Units |
|------------------------------------|-----------------|-------------|---------|---------|-------|
| Mode of Oscillation                | —               | Fundamental |         |         |       |
| Frequency                          | —               | —           | 52      | —       | MHz   |
| Frequency Tolerance <sup>1</sup>   | After trimming  | —           | —       | ±20     | ppm   |
| Equivalent Series Resistance (ESR) | —               | —           | —       | 80      | Ω     |
| Shunt Capacitance                  | —               | —           | 2       | 7       | pF    |
| Load Capacitance (C <sub>L</sub> ) | —               | 6           | 8       | 10      | pF    |
| Maximum Crystal Drive Level        | —               | —           | —       | 100     | μW    |

<sup>1</sup> Frequency tolerance includes initial frequency, over temperature range and aging data.

## DC Electrical Characteristics

Table 11. DC Electrical Characteristics – Current

V<sub>DD</sub> = V<sub>DDO</sub> = 1.8V ±5%, V<sub>SS</sub> = 0V, T<sub>A</sub> = -40°C to +85°C.

| Symbol              | Parameter                                     | Conditions  | Minimum | Typical | Maximum | Units |
|---------------------|---|---|---------|---------|---------|-------|
| I <sub>dd</sub>     | Core Supply Current (5X1503/5X1503L)          | V <sub>DD</sub> = V <sub>DDO</sub> = 1.8V, Xtal = 52MHz, DCO = OFF, no output; PLL default.     | —       | —       | 2.0     | mA    |
|                     | Core Supply Current (5X1503S)                 | V <sub>DD</sub> = V <sub>DDO</sub> = 1.8V, Xtal = 52MHz, DCO = OFF, no output; PLL default.     | —       | —       | 9.5     | mA    |
| I <sub>dd_PLL</sub> | PLL Supply Current (5X1503/5X1503L)           | V <sub>DD</sub> = V <sub>DDO</sub> = 1.8V, Xtal = 52MHz, no output; PLL= default                | —       | —       | 1.0     | mA    |
|                     | PLL Supply Current (5X1503S)                  | V <sub>DD</sub> = V <sub>DDO</sub> = 1.8V, Xtal = 52MHz, no output; PLL= default                | —       | —       | 9.0     | mA    |
| I <sub>ddox</sub>   | Output Buffer Supply Current (5X1503/5X1503L) | LVC MOS, OUT1 = 8MHz, V <sub>DD</sub> = V <sub>DDO</sub> = 1.8V.                                | —       | —       | 0.5     | mA    |
|                     |   | LVC MOS, OUT1 = 100MHz, V <sub>DD</sub> = V <sub>DDO</sub> = 1.8V.                              | —       | —       | 2       | mA    |
|                     | Output Buffer Supply Current (5X1503S)        | LVC MOS, OUT1 = 8MHz, V <sub>DD</sub> = V <sub>DDO</sub> = 1.8V.                                | —       | —       | 0.5     | mA    |
|                     |   | LVC MOS, OUT1 = 100MHz, V <sub>DD</sub> = V <sub>DDO</sub> = 1.8V.                              | —       | —       | 2       | mA    |
| I <sub>ddpd</sub>   | Power Down Current (5X1503/5X1503L)           | PD asserted with V <sub>DD</sub> and V <sub>DDO</sub> ON, I2C enable, 32.768kHz clock running.  | —       | —       | 310     | μA    |
|                     | Power Down Current (5X1503S)                  | PD asserted with V <sub>DD</sub> and V <sub>DDO</sub> ON, I2C enable, 32.768kHz clock running.  | —       | —       | 320     | μA    |
| I <sub>ddupd</sub>  | Ultra Power Down Current (5X1503/5X1503L)     | PD asserted with V <sub>DD</sub> and V <sub>DDO</sub> ON, I2C disable, 32.768kHz clock running. | —       | —       | 7       | μA    |
|                     | Ultra Power Down Current (5X1503S)            | PD asserted with V <sub>DD</sub> and V <sub>DDO</sub> ON, I2C disable, 32.768kHz clock running. | —       | —       | 9.5     | μA    |

Table 11. DC Electrical Characteristics – Current (Cont.)

$V_{DD} = V_{DDO} = 1.8V \pm 5\%$ ,  $V_{SS} = 0V$ ,  $T_A = -40^\circ C$  to  $+85^\circ C$ .

| Symbol                 | Parameter                       | Conditions  | Minimum | Typical | Maximum | Units   |
|------------------------|---------------------------------|---|---------|---------|---------|---------|
| I <sub>ddsuspend</sub> | Power Suspend Current (5X1503)  | $V_{DDD} = 1.8V$ , $V_{DDO} = GND$ , OUT1 = 32.768kHz running in DCO mode, no output loads, I2C and OE pins open. | —       | —       | 1.4     | $\mu A$ |
|                        | Power Suspend Current (5X1503L) | $V_{DDD} = 1.8V$ , $V_{DDO} = GND$ , OUT1 = 32.768kHz running in DCO mode, no output loads, I2C and OE pins open. | —       | —       | 1       | $\mu A$ |
|                        | Power Suspend Current (5X1503S) | $V_{DDD} = 1.8V$ , $V_{DDO} = GND$ , OUT1 = 32.768kHz running in DCO mode, no output loads, I2C and OE pins open. | —       | —       | 1.4     | $\mu A$ |

Table 12. DC Electrical Characteristics – Input and Output Voltage

| Symbol     | Parameter              | Conditions                               | Minimum               | Typical | Maximum               | Units   |
|------------|------------------------|--|-----------------------|---------|-----------------------|---------|
| $V_{OH}$   | Output High Voltage    | $I_{OH} = -8mA$ .                        | $0.7 \times V_{DDO}$  | —       | $V_{DDO}$             | V       |
| $V_{OL}$   | Output Low Voltage     | $I_{OL} = 8mA$ .                         | —                     | —       | $0.25 \times V_{DDO}$ | V       |
| $I_{OZDD}$ | Output Leakage Current | Tri-state outputs, $V_{DDO} = 1.89V$ .   | —                     | —       | 80                    | $\mu A$ |
| $V_{IH}$   | Input High Voltage     | Single-ended inputs – DFC, OE, SDA, SCL. | $0.65 \times V_{DDO}$ | —       | $V_{DDO} + 0.3$       | V       |
| $V_{IL}$   | Input Low Voltage      | Single-ended inputs – DFC, OE, SDA, SCL. | $GND - 0.3$           | —       | $0.35 \times V_{DDO}$ | V       |

## AC Electrical Characteristics

Table 13. AC Timing Electrical Characteristics

$V_{DDSE} = 1.8V \pm 5\%$ ,  $T_A = -40^\circ C$  to  $+85^\circ C$ . Spread spectrum = OFF.

| Symbol          | Parameter                   | Conditions  | Minimum | Typical | Maximum | Units |
|-----------------|-----------------------------|---|---------|---------|---------|-------|
| $f_{IN}$        | Integrated Xtal Frequency   | Input frequency limit (XIN) <sup>1</sup> .          | —       | 52      | —       | MHz   |
| $f_{OUT}$       | Output Frequency            | Single-ended clock output limit (LVCMOS).           | 1       | —       | 100     | MHz   |
| $f_{VCO1}$      | VCO Frequency Range of PLL  | VCO operating frequency range (5X1503).             | 50      | —       | 130     | MHz   |
| $f_{VCO2}$      | VCO Frequency Range of PLL  | VCO operating frequency range (5X1503L).            | 50      | —       | 130     | MHz   |
| $f_{VCO3}$      | VCO Frequency Range of PLL  | VCO operating frequency range (5X1503S).            | 500     | —       | 1100    | MHz   |
| $f_{PFD1}$      | PFD Frequency Range of PLL1 | PFD operating frequency range (5X1503 and 5X1503L). | 0       | —       | 0.125   | MHz   |
| $f_{PFD1}$      | PFD Frequency Range of PLL1 | PFD operating frequency range (5X1503S).            | 0.8     | —       | 100     | MHz   |
| $f_{BW1}$       | Loop Bandwidth for PLL1     | Input frequency = 52MHz.                            | 0.001   | —       | 1       | MHz   |
| $F_{32K\_ACC1}$ | 32K Stability               | Average accuracy after 24 hours <sup>2</sup> .      | —       | —       | 42      | ppm   |
| $F_{32K\_ACC2}$ | 32K Stability               | Average accuracy after 3 days <sup>2</sup> .        | —       | —       | 36      | ppm   |
| $F_{32K\_ACC3}$ | 32K Stability               | Average accuracy after 7 days <sup>2</sup> .        | —       | —       | 32      | ppm   |

Table 13. AC Timing Electrical Characteristics (Cont.)

$V_{DDSE} = 1.8V \pm 5\%$ ,  $T_A = -40^\circ C$  to  $+85^\circ C$ . Spread spectrum = OFF.

| Symbol          | Parameter               | Conditions   | Minimum | Typical | Maximum  | Units |
|-----------------|-------------------------|--|---------|---------|----------|-------|
|                 | Minimum Input Amplitude | For a 40/60% SE input duty cycle.  | 800     | —       | $V_{DD}$ | mV    |
| t2              | Input Duty Cycle        | Duty cycle.  | 30      | —       | 70       | %     |
| t3              | Output Duty Cycle       | Measured at $V_{DD}/2$ , all outputs with a crystal or a 50% input duty cycle clock.   | 45      | —       | 55       | %     |
| t4 <sup>3</sup> | Rise/Fall Slew Rate     | 1.8V LVCMOS clock rise and fall time, 20% to 80% of $V_{DDO}/V_{DD}$ (output load = 2 pF).                                       | —       | 2.0     | —        | V/ns  |
| t4 <sup>3</sup> | Rise/Fall Slew Rate     | 1.2V LVCMOS clock rise and fall time, 20% to 80% of $V_{DDO}/V_{DD}$ (output load = 2 pF).<br>Byte19<3:2> = 11 Byte19<1:0> = 11. | —       | 1.1     | —        | V/ns  |
| t4 <sup>3</sup> | Rise/Fall Slew Rate     | 1.1V LVCMOS clock rise and fall time, 20% to 80% of $V_{DDO}/V_{DD}$ (output load = 2 pF).                                       | —       | 1.0     | —        | V/ns  |
| t4 <sup>3</sup> | Rise/Fall Slew Rate     | 1.0V LVCMOS clock rise and fall time, 20% to 80% of $V_{DDO}/V_{DD}$ (output load = 2 pF).                                       | —       | 1.0     | —        | V/ns  |
| t4 <sup>3</sup> | Rise/Fall Slew          | OUT1 1.8V 32kHz LVCMOS clock rise and fall time, 20% to 80% of $V_{DDO}/V_{DD}$ ,<br>Byte20<2:0>=000 (5X1503L).                  | —       | 27.4    | —        | V/μs  |
| t4 <sup>3</sup> | Rise/Fall Slew          | OUT1 0.8V 32kHz LVCMOS clock rise and fall time, 20% to 80% of $V_{DDO}/V_{DD}$ ,<br>Byte20<2:0> = 001 (5X1503L).                | —       | 2.3     | —        | V/μs  |
| t4 <sup>3</sup> | Rise/Fall Slew          | OUT1 0.9V 32kHz LVCMOS clock rise and fall time, 20% to 80% of $V_{DDO}/V_{DD}$ ,<br>Byte20<2:0> = 010 (5X1503L).                | —       | 3.9     | —        | V/μs  |
| t4 <sup>3</sup> | Rise/Fall Slew          | OUT1 1.0V 32kHz LVCMOS clock rise and fall time, 20% to 80% of $V_{DDO}/V_{DD}$ ,<br>Byte20<2:0> = 011 (5X1503L).                | —       | 5.4     | —        | V/μs  |
| t4 <sup>3</sup> | Rise/Fall Slew          | OUT1 1.1V 32kHz LVCMOS clock rise and fall time, 20% to 80% of $V_{DDO}/V_{DD}$ ,<br>Byte20<2:0> = 100 (5X1503L).                | —       | 6.7     | —        | V/μs  |
| t4 <sup>3</sup> | Rise/Fall Slew          | OUT1 1.2V 32kHz LVCMOS clock rise and fall time, 20% to 80% of $V_{DDO}/V_{DD}$ ,<br>Byte20<2:0> = 101 (5X1503L).                | —       | 8.5     | —        | V/μs  |
| t6 <sup>4</sup> | Clock Jitter            | Cycle-to-cycle jitter, 1.8V LVCMOS output clock.<br>OUT1 = 32.768KHz (1.8V LVCMOS)<br>OUT2 = 72MHz<br>OUT3 = 26MHz               | —       | 50      | —        | ps    |
| t6 <sup>4</sup> | Clock Jitter            | Cycle-to-cycle jitter, 1.2V LVCMOS output clock.<br>OUT1 = 32.768KHz (1.8V LVCMOS)<br>OUT2 = 72MHz<br>OUT3 = 26MHz               | —       | 50      | —        | ps    |

Table 13. AC Timing Electrical Characteristics (Cont.)

$V_{DDSE} = 1.8V \pm 5\%$ ,  $T_A = -40^\circ C$  to  $+85^\circ C$ . Spread spectrum = OFF.

| Symbol | Parameter    | Conditions   | Minimum | Typical | Maximum | Units |
|--------|--------------|--|---------|---------|---------|-------|
| $t6^4$ | Clock Jitter | Cycle-to-cycle jitter, 1.1V LVCMOS output clock<br>OUT1 = 32.768kHz (1.8V LVCMOS)<br>OUT2 = 72MHz<br>OUT3 = 26MHz  | —       | 50      | —       | ps    |
| $t6^4$ | Clock Jitter | Cycle-to-cycle jitter, 1.0V LVCMOS output clock.<br>OUT1 = 32.768kHz (1.8V LVCMOS)<br>OUT2 = 72MHz<br>OUT3 = 26MHz | —       | 50      | —       | ps    |
| $t7$   | Output Skew  | Skew between the same frequencies, with outputs using the same driver format.                                      | —       |         | 300     | ps    |
| $t8^5$ | Lock Time    | PLL lock time from power-up.   | —       |         | 5       | ms    |
| $t9$   | Lock Time    | 32.768kHz clock low power power-up time.   | —       | 10      | 20      | ms    |

<sup>1</sup> High Drive only when crystal frequency is higher than 30MHz.

<sup>2</sup> The data is measured on constant temperature.

<sup>3</sup> The slew rate is set by Byte19<3:2> and Byte19<1:0>.

<sup>4</sup> Jitter performance depend on output configuration.

<sup>5</sup> Includes loading the configuration bits from EPROM to PLL registers. It does not include EPROM programming/write time.

<sup>6</sup> Actual PLL lock time depends on the loop configuration.

## I<sup>2</sup>C Bus DC Characteristics

Table 14. I<sup>2</sup>C Bus DC Characteristics

| Symbol    | Parameter             | Conditions       | Minimum               | Typical | Maximum              | Units   |
|-----------|-----------------------|------------------|-----------------------|---------|----------------------|---------|
| $V_{IH}$  | Input High Level      | —                | $0.7 \times V_{DDO}$  | —       | —                    | V       |
| $V_{IL}$  | Input Low Level       | —                | —                     | —       | $0.3 \times V_{DDO}$ | V       |
| $V_{HYS}$ | Hysteresis of Inputs  | —                | $0.05 \times V_{DDO}$ | —       | —                    | V       |
| $I_{IN}$  | Input Leakage Current | —                | —                     | 1       | 10                   | $\mu A$ |
| $V_{OL}$  | Output Low Voltage    | $I_{OL} = 3mA$ . | —                     | —       | 0.4                  | V       |

Note: I2C bus is 3.3V tolerant.

Table 15. I<sup>2</sup>C Bus AC Characteristics

| Symbol                | Parameter                                | Minimum                   | Typical | Maximum | Units |
|-----------------------|--|---------------------------|---------|---------|-------|
| F <sub>SCLK</sub>     | Serial Clock Frequency (SCL)             | —                         | 100     | 400     | kHz   |
| t <sub>BUF</sub>      | Bus Free Time between STOP and START     | 1.3                       | —       | —       | μs    |
| t <sub>SU:START</sub> | Setup Time, START                        | 0.6                       | —       | —       | μs    |
| t <sub>HD:START</sub> | Hold Time, START                         | 0.6                       | —       | —       | μs    |
| t <sub>SU:DATA</sub>  | Setup Time, Data Input (SDA)             | 100                       | —       | —       | ns    |
| t <sub>HD:DATA</sub>  | Hold Time, Data Input (SDA) <sup>1</sup> | 0                         | —       | —       | μs    |
| t <sub>OVD</sub>      | Output Data Valid from Clock             | —                         | —       | 0.9     | μs    |
| C <sub>B</sub>        | Capacitive Load for Each Bus Line        | —                         | —       | 400     | pF    |
| t <sub>R</sub>        | Rise Time, Data and Clock (SDA, SCL)     | 20 + 0.1 × C <sub>B</sub> | —       | 300     | ns    |
| t <sub>F</sub>        | Fall Time, Data and Clock (SDA, SCL)     | 20 + 0.1 × C <sub>B</sub> | —       | 300     | ns    |
| t <sub>HIGH</sub>     | High Time, Clock (SCL)                   | 0.6                       | —       | —       | μs    |
| t <sub>LOW</sub>      | Low Time, Clock (SCL)                    | 1.3                       | —       | —       | μs    |
| t <sub>SU:STOP</sub>  | Setup Time, STOP                         | 0.6                       | —       | —       | μs    |

<sup>1</sup> A device must internally provide a hold time of at least 300ns for the SDA signal (referred to the V<sub>IH(MIN)</sub> of the SCL signal) to bridge the undefined region of the falling edge of SCL.

## Spread Spectrum Generation Specifications

Table 16. Spread Spectrum Generation Specifications (5X1503S only)

| Symbol              | Parameter        | Description  | Minimum      | Typical | Maximum | Units              |
|---------------------|------------------|--|--------------|---------|---------|--------------------|
| f <sub>OUT</sub>    | Output Frequency | Output frequency range.                            | 1            | —       | 100     | MHz                |
| f <sub>MOD</sub>    | Mod Frequency    | Modulation frequency.                              | 30 – 63      |         |         | kHz                |
| f <sub>SPREAD</sub> | Spread Value     | Amount of spread value (programmable)–down spread. | 0.15% – 2.0% |         |         | % f <sub>OUT</sub> |

## General I2C Interface Information

### How to Write

- Controller (host) sends a start bit
- Controller (host) sends the write address
- IDT clock will acknowledge
- Controller (host) sends the beginning byte location = N
- IDT clock will acknowledge
- Controller (host) sends the byte count = X
- IDT clock will acknowledge
- Controller (host) starts sending Byte N through Byte N+X-1
- IDT clock will acknowledge each byte one at a time
- Controller (host) sends a stop bit

| Index Block Write Operation |           |                      |     |
|-----------------------------|-----------|----------------------|-----|
| Controller (Host)           |           | IDT (Slave/Receiver) |     |
| T                           | starT bit |                      |     |
| Slave Address               |           |                      |     |
| WR                          | WRite     |                      |     |
|                             |           |                      | ACK |
| Beginning Byte = N          |           |                      |     |
|                             |           |                      | ACK |
| Data Byte Count = X         |           |                      |     |
|                             |           |                      | ACK |
| Beginning Byte N            |           | X Byte               |     |
|                             |           |                      | ACK |
| 0                           |           |                      | 0   |
| 0                           |           |                      | 0   |
| 0                           |           |                      | 0   |
| Byte N + X - 1              |           |                      |     |
|                             |           |                      | ACK |
| P                           | stoP bit  |                      |     |

### How to Read

- Controller (host) will send a start bit
- Controller (host) sends the write address
- IDT clock will acknowledge
- Controller (host) sends the beginning byte location = N
- IDT clock will acknowledge
- Controller (host) will send a separate start bit
- Controller (host) sends the read address
- IDT clock will acknowledge
- IDT clock will send the data byte count = X
- IDT clock sends Byte N+X-1
- IDT clock sends Byte 0 through Byte X (if  $X_{(H)}$  was written to Byte 8)
- Controller (host) will need to acknowledge each byte
- Controller (host) will send a not acknowledge bit
- Controller (host) will send a stop bit

| Index Block Read Operation |                 |                      |                   |
|----------------------------|-----------------|----------------------|-------------------|
| Controller (Host)          |                 | IDT (Slave/Receiver) |                   |
| T                          | starT bit       |                      |                   |
| Slave Address              |                 |                      |                   |
| WR                         | WRite           |                      |                   |
|                            |                 |                      | ACK               |
| Beginning Byte = N         |                 |                      |                   |
|                            |                 |                      | ACK               |
| RT                         | Repeat starT    |                      |                   |
| Slave Address              |                 |                      |                   |
| RD                         | ReaD            |                      |                   |
|                            |                 |                      | ACK               |
|                            |                 |                      | Data Byte Count=X |
|                            |                 |                      | ACK               |
|                            |                 | X Byte               | Beginning Byte N  |
|                            |                 |                      | 0                 |
|                            |                 |                      | 0                 |
|                            |                 |                      | 0                 |
|                            |                 |                      | 0                 |
|                            |                 |                      | Byte N + X - 1    |
| N                          | Not acknowledge |                      |                   |
| P                          | stoP bit        |                      |                   |



### Byte 0: General Control

| Byte 00h | Name                     | Control Function                  | Type | 0  | 1                        | PWD |
|----------|--------------------------|-----------------------------------|------|--|--------------------------|-----|
| Bit 7    | OTP_Burned               | OTP memory programming indication | R/W  | OTP memory non-programmed  | OTP memory programmed    | 0   |
| Bit 6    | OTP TRIM                 | OTP memory programming indication | R/W  | OTP TRIM bits non-programmed   | OTP TRIM bits programmed | 0   |
| Bit 5    | I2C_addr[1]              | I2C address select bit 1          | R/W  | 00: D0 / 01: D2<br>10: D4 / 11: D6   |                          | 0   |
| Bit 4    | I2C_addr[0]              | I2C address select bit 0          | R/W  |  |                          | 0   |
| Bit 3    | OTP TRIM Protect         | OTP TRIM bits memory protection   | R/W  | read/write   | write locked             | 0   |
| Bit 2    | OTP Configure Select 2   | OTP Config Select Bit             | R/W  | Config 0   | Config 1                 | 0   |
| Bit 1    | OTP Configure Select <1> | DFC Config Select Bit 1           | R/W  | 00: DFC Config 0<br>01: DFC Config 1<br>10: DFC Config 2<br>11: DFC Config 3 |                          | 0   |
| Bit 0    | OTP Configure Select <0> | DFC Config Select Bit 0           | R/W  |  |                          | 0   |

### Byte 1: Dash Code ID (optional)

| Byte 01h | Name           | Control Function | Type | 0      | 1      | PWD |
|----------|----------------|------------------|------|--------|--------|-----|
| Bit 7    | XTAL_DIV2      | XTAL Divider     | R/W  | Div /2 | Bypass | 0   |
| Bit 6    | DashCode ID[6] | Dash code ID     | R/W  | —      | —      | 0   |
| Bit 5    | DashCode ID[5] | Dash code ID     | R/W  | —      | —      | 0   |
| Bit 4    | DashCode ID[4] | Dash code ID     | R/W  | —      | —      | 0   |
| Bit 3    | DashCode ID[3] | Dash code ID     | R/W  | —      | —      | 0   |
| Bit 2    | DashCode ID[2] | Dash code ID     | R/W  | —      | —      | 0   |
| Bit 1    | DashCode ID[1] | Dash code ID     | R/W  | —      | —      | 0   |
| Bit 0    | DashCode ID[0] | Dash code ID     | R/W  | —      | —      | 0   |

### Byte 2: Crystal Cap Setting

| Byte 02h | Name           | Control Function            | Type | 0  | 1 | PWD |
|----------|----------------|-----------------------------|------|--|---|-----|
| Bit 7    | Xtal_Cap[3]    | Xtal cap load trimming bits | R/W  | x1 x2<br>x4 x8<br>total 15pF                 |   | 0   |
| Bit 6    | Xtal_Cap[2]    | Xtal cap load trimming bits | R/W  |  |   | 0   |
| Bit 5    | Xtal_Cap[1]    | Xtal cap load trimming bits | R/W  |  |   | 0   |
| Bit 4    | Xtal_Cap[0]    | Xtal cap load trimming bits | R/W  |  |   | 1   |
| Bit 3    | PPS Hyst Prog  | PPS Hysteresis Prog Bit1    | R/W  | 00: 20mV<br>01: 40mV<br>10: 60mV<br>11: 80mV |   | 0   |
| Bit 2    | PPS Hyst Prog  | PPS Hysteresis Prog Bit0    | R/W  |  |   | 0   |
| Bit 1    | PPS Vbias Prog | PPS Vbias Prog Bit 1        | R/W  | —  | — | 0   |
| Bit 0    | PPS Vbias Prog | PPS Vbias Prog Bit 0        | R/W  | —  | — | 0   |

**Byte 3: OTP Protect**

| Byte 03h | Name                    | Control Function             | Type | 0  | 1            | PWD |
|----------|-------------------------|------------------------------|------|--|--------------|-----|
| Bit 7    | OTP Configure 3 Protect | —                            | R/W  | read/write                                       | write locked | 0   |
| Bit 6    | OTP Configure 2 Protect | —                            | R/W  | read/write                                       | write locked | 0   |
| Bit 5    | OTP Configure 1 Protect | —                            | R/W  | read/write                                       | write locked | 0   |
| Bit 4    | OTP Configure 0 Protect | —                            | R/W  | read/write                                       | write locked | 0   |
| Bit 3    | PPS2 Amp Prog           | PPS OE2 Amplitude Prog Bit 1 | R/W  | 00: 400mV<br>01: 500mV<br>10: 600mV<br>11: 700mV |              | 0   |
| Bit 2    | PPS2 Amp Prog           | PPS OE2 Amplitude Prog Bit 0 | R/W  |  |              | 0   |
| Bit 1    | PPS1 Amp Prog           | PPS OE1 Amplitude Prog Bit 1 | R/W  | 00: 400mV<br>01: 500mV<br>10: 600mV<br>11: 700mV |              | 0   |
| Bit 0    | PPS1 Amp Prog           | PPS OE1 Amplitude Prog Bit 0 | R/W  |  |              | 0   |

**Byte 4: (Apply to 5X1503S)**

| Byte 04h | Name           | Control Function                   | Type | 0        | 1                     | PWD |
|----------|----------------|------------------------------------|------|----------|-----------------------|-----|
| Bit 7    | UltraPowerDown | Ultra Power Down                   | R/W  | disabled | enabled               | 0   |
| Bit 6    | EN DIFF CLKIN  | Enable Differential Clkin on X1/X2 | R/W  | disabled | enabled               | 0   |
| Bit 5    | PLL HRS EN     | -                                  | R/W  | normal   | enable (shift 4 bits) | 0   |
| Bit 4    | PLL EN 3rd     | -                                  | R/W  | disabled | enabled               | 0   |
| Bit 3    | Reserved       |                                    | R/W  | —        | —                     | 0   |
| Bit 2    | PLL_FB_INT[10] | PLL feedback integer divider 10    | R/W  | —        | —                     | 0   |
| Bit 1    | PLL_FB_INT[9]  | PLL feedback integer divider 9     | R/W  | —        | —                     | 0   |
| Bit 0    | PLL_FB_INT[8]  | PLL feedback integer divider 8     | R/W  | —        | —                     | 0   |

**Byte 4: (Apply to 5X1503/5X1503L)**

| Byte 04h | Name           | Control Function                   | Type | 0        | 1                     | PWD |
|----------|----------------|------------------------------------|------|----------|-----------------------|-----|
| Bit 7    | UltraPowerDown | Ultra Power Down                   | R/W  | disabled | enabled               | 0   |
| Bit 6    | EN DIFF CLKIN  | Enable Differential Clkin on X1/X2 | R/W  | disabled | enabled               | 0   |
| Bit 5    | PLL HRS EN     | —                                  | R/W  | normal   | enable (shift 4 bits) | 0   |
| Bit 4    | PLL EN 3rd     | —                                  | R/W  | disabled | enabled               | 0   |
| Bit 3    | SEL_PREDIV     | Divide by 4                        | R/W  | disabled | enabled               | 0   |
| Bit 2    | PLL_FB_INT[10] | PLL feedback integer divider 10    | R/W  | —        | —                     | 0   |
| Bit 1    | PLL_FB_INT[9]  | PLL feedback integer divider 9     | R/W  | —        | —                     | 0   |
| Bit 0    | PLL_FB_INT[8]  | PLL feedback integer divider 8     | R/W  | —        | —                     | 0   |

**Byte 5: PLL Integer Feedback Divider (Apply to 5X1503S)**

| Byte 05h | Name              | Control Function               | Type | 0 | 1 | PWD |
|----------|-------------------|--------------------------------|------|---|---|-----|
| Bit 7    | PLL_FB_INT_DIV[7] | PLL feedback integer divider 7 | R/W  | — | — | 0   |
| Bit 6    | PLL_FB_INT_DIV[6] | PLL feedback integer divider 6 | R/W  | — | — | 0   |
| Bit 5    | PLL_FB_INT_DIV[5] | PLL feedback integer divider 5 | R/W  | — | — | 1   |
| Bit 4    | PLL_FB_INT_DIV[4] | PLL feedback integer divider 4 | R/W  | — | — | 0   |
| Bit 3    | PLL_FB_INT_DIV[3] | PLL feedback integer divider 3 | R/W  | — | — | 1   |
| Bit 2    | PLL_FB_INT_DIV[2] | PLL feedback integer divider 2 | R/W  | — | — | 0   |
| Bit 1    | PLL_FB_INT_DIV[1] | PLL feedback integer divider 1 | R/W  | — | — | 0   |
| Bit 0    | PLL_FB_INT_DIV[0] | PLL feedback integer divider 0 | R/W  | — | — | 0   |

**Byte 5: PLL Integer Feedback Divider (Apply to 5X1503/5X1503L)**

| Byte 05h | Name              | Control Function               | Type | 0 | 1 | PWD |
|----------|-------------------|--------------------------------|------|---|---|-----|
| Bit 7    | PLL_FB_INT_DIV[7] | PLL feedback integer divider 7 | R/W  | — | — | 0   |
| Bit 6    | PLL_FB_INT_DIV[6] | PLL feedback integer divider 6 | R/W  | — | — | 0   |
| Bit 5    | PLL_FB_INT_DIV[5] | PLL feedback integer divider 5 | R/W  | — | — | 1   |
| Bit 4    | PLL_FB_INT_DIV[4] | PLL feedback integer divider 4 | R/W  | — | — | 1   |
| Bit 3    | PLL_FB_INT_DIV[3] | PLL feedback integer divider 3 | R/W  | — | — | 0   |
| Bit 2    | PLL_FB_INT_DIV[2] | PLL feedback integer divider 2 | R/W  | — | — | 0   |
| Bit 1    | PLL_FB_INT_DIV[1] | PLL feedback integer divider 1 | R/W  | — | — | 0   |
| Bit 0    | PLL_FB_INT_DIV[0] | PLL feedback integer divider 0 | R/W  | — | — | 0   |

**Byte 6: PLL Fractional Feedback Divider**

| Byte 06h | Name               | Control Function                   | Type | 0 | 1 | PWD |
|----------|--------------------|------------------------------------|------|---|---|-----|
| Bit 7    | PLL_FB_FRC_DIV[15] | PLL feedback fractional divider 15 | R/W  | — | — | 0   |
| Bit 6    | PLL_FB_FRC_DIV[14] | PLL feedback fractional divider 14 | R/W  | — | — | 0   |
| Bit 5    | PLL_FB_FRC_DIV[13] | PLL feedback fractional divider 13 | R/W  | — | — | 0   |
| Bit 4    | PLL_FB_FRC_DIV[12] | PLL feedback fractional divider 12 | R/W  | — | — | 0   |
| Bit 3    | PLL_FB_FRC_DIV[11] | PLL feedback fractional divider 11 | R/W  | — | — | 0   |
| Bit 2    | PLL_FB_FRC_DIV[10] | PLL feedback fractional divider 10 | R/W  | — | — | 0   |
| Bit 1    | PLL_FB_FRC_DIV[9]  | PLL feedback fractional divider 9  | R/W  | — | — | 0   |
| Bit 0    | PLL_FB_FRC_DIV[8]  | PLL feedback fractional divider 8  | R/W  | — | — | 0   |

### Byte 7: Fractional Feedback Divider

| Byte 07h | Name              | Control Function                  | Type | 0 | 1 | PWD |
|----------|-------------------|-----------------------------------|------|---|---|-----|
| Bit 7    | PLL_FB_FRC_DIV[7] | PLL feedback fractional divider 7 | R/W  | — | — | 0   |
| Bit 6    | PLL_FB_FRC_DIV[6] | PLL feedback fractional divider 6 | R/W  | — | — | 0   |
| Bit 5    | PLL_FB_FRC_DIV[5] | PLL feedback fractional divider 5 | R/W  | — | — | 0   |
| Bit 4    | PLL_FB_FRC_DIV[4] | PLL feedback fractional divider 4 | R/W  | — | — | 0   |
| Bit 3    | PLL_FB_FRC_DIV[3] | PLL feedback fractional divider 3 | R/W  | — | — | 0   |
| Bit 2    | PLL_FB_FRC_DIV[2] | PLL feedback fractional divider 2 | R/W  | — | — | 0   |
| Bit 1    | PLL_FB_FRC_DIV[1] | PLL feedback fractional divider 1 | R/W  | — | — | 0   |
| Bit 0    | PLL_FB_FRC_DIV[0] | PLL feedback fractional divider 0 | R/W  | — | — | 0   |

### Byte 8: PLL Spread Spectrum Control

| Byte 08h | Name         | Control Function                    | Type | 0 | 1 | PWD |
|----------|--------------|-------------------------------------|------|---|---|-----|
| Bit 7    | PLL_STEP[15] | PLL spread step size control bit 15 | R/W  | — | — | 0   |
| Bit 6    | PLL_STEP[14] | PLL spread step size control bit 14 | R/W  | — | — | 0   |
| Bit 5    | PLL_STEP[13] | PLL spread step size control bit 13 | R/W  | — | — | 0   |
| Bit 4    | PLL_STEP[12] | PLL spread step size control bit 12 | R/W  | — | — | 0   |
| Bit 3    | PLL_STEP[11] | PLL spread step size control bit 11 | R/W  | — | — | 0   |
| Bit 2    | PLL_STEP[10] | PLL spread step size control bit 10 | R/W  | — | — | 0   |
| Bit 1    | PLL_STEP[9]  | PLL spread step size control bit 9  | R/W  | — | — | 0   |
| Bit 0    | PLL_STEP[8]  | PLL spread step size control bit 8  | R/W  | — | — | 0   |

### Byte 9: PLL Spread Spectrum Control

| Byte 09h | Name        | Control Function                   | Type | 0 | 1 | PWD |
|----------|-------------|------------------------------------|------|---|---|-----|
| Bit 7    | PLL_STEP[7] | PLL spread step size control bit 7 | R/W  | — | — | 0   |
| Bit 6    | PLL_STEP[6] | PLL spread step size control bit 6 | R/W  | — | — | 0   |
| Bit 5    | PLL_STEP[5] | PLL spread step size control bit 5 | R/W  | — | — | 0   |
| Bit 4    | PLL_STEP[4] | PLL spread step size control bit 4 | R/W  | — | — | 0   |
| Bit 3    | PLL_STEP[3] | PLL spread step size control bit 3 | R/W  | — | — | 0   |
| Bit 2    | PLL_STEP[2] | PLL spread step size control bit 2 | R/W  | — | — | 0   |
| Bit 1    | PLL_STEP[1] | PLL spread step size control bit 1 | R/W  | — | — | 0   |
| Bit 0    | PLL_STEP[0] | PLL spread step size control bit 0 | R/W  | — | — | 0   |

### Byte 10: PLL Period Control

| Byte 0Ah | Name          | Control Function         | Type | 0 | 1 | PWD |
|----------|---------------|--------------------------|------|---|---|-----|
| Bit 7    | PLL_PERIOD[7] | PLL period control bit 7 | R/W  | — | — | 0   |
| Bit 6    | PLL_PERIOD[6] | PLL period control bit 6 | R/W  | — | — | 0   |
| Bit 5    | PLL_PERIOD[5] | PLL period control bit 5 | R/W  | — | — | 0   |
| Bit 4    | PLL_PERIOD[4] | PLL period control bit 4 | R/W  | — | — | 0   |
| Bit 3    | PLL_PERIOD[3] | PLL period control bit 3 | R/W  | — | — | 0   |
| Bit 2    | PLL_PERIOD[2] | PLL period control bit 2 | R/W  | — | — | 0   |
| Bit 1    | PLL_PERIOD[1] | PLL period control bit 1 | R/W  | — | — | 0   |
| Bit 0    | PLL_PERIOD[0] | PLL period control bit 0 | R/W  | — | — | 0   |

### Byte 11: PLL M Divider Setting (Apply to 5X1503S)

| Byte 0Bh | Name        | Control Function                    | Type | 0                   | 1                   | PWD |
|----------|-------------|-------------------------------------|------|---------------------|---------------------|-----|
| Bit 7    | PLL_MDIV1   | PLL reference divider 1             | R/W  | disable M DIV1      | bypadd divider (/1) | 1   |
| Bit 6    | PLL_MDIV2   | PLL reference divider 2             | R/W  | disable M DIV2      | bypadd divider (/2) | 0   |
| Bit 5    | PLL_MDIV[5] | PLL reference divider control bit 5 | R/W  | 3–63, default is 26 |                     | 0   |
| Bit 4    | PLL_MDIV[4] | PLL reference divider control bit 4 | R/W  |                     |                     | 1   |
| Bit 3    | PLL_MDIV[3] | PLL reference divider control bit 3 | R/W  |                     |                     | 1   |
| Bit 2    | PLL_MDIV[2] | PLL reference divider control bit 2 | R/W  |                     |                     | 0   |
| Bit 1    | PLL_MDIV[1] | PLL reference divider control bit 1 | R/W  |                     |                     | 1   |
| Bit 0    | PLL_MDIV[0] | PLL reference divider control bit 0 | R/W  |                     |                     | 0   |

### Byte 11: PLL M Divider Setting (Apply to 5X1503/5X1503L)

| Byte 0Bh | Name        | Control Function                    | Type | 0                   | 1                   | PWD |
|----------|-------------|-------------------------------------|------|---------------------|---------------------|-----|
| Bit 7    | PLL_MDIV1   | PLL reference divider 1             | R/W  | disable M DIV1      | bypadd divider (/1) | 0   |
| Bit 6    | PLL_MDIV2   | PLL reference divider 2             | R/W  | disable M DIV2      | bypadd divider (/2) | 0   |
| Bit 5    | PLL_MDIV[5] | PLL reference divider control bit 5 | R/W  | 3–63, default is 26 |                     | 0   |
| Bit 4    | PLL_MDIV[4] | PLL reference divider control bit 4 | R/W  |                     |                     | 1   |
| Bit 3    | PLL_MDIV[3] | PLL reference divider control bit 3 | R/W  |                     |                     | 1   |
| Bit 2    | PLL_MDIV[2] | PLL reference divider control bit 2 | R/W  |                     |                     | 0   |
| Bit 1    | PLL_MDIV[1] | PLL reference divider control bit 1 | R/W  |                     |                     | 1   |
| Bit 0    | PLL_MDIV[0] | PLL reference divider control bit 0 | R/W  |                     |                     | 0   |

**Byte 12: PLL Loop R Setting (Apply to 5X1503S)**

| Byte 0Ch | Name             | Control Function                  | Type | 0       | 1                  | PWD |
|----------|------------------|-----------------------------------|------|---------|--------------------|-----|
| Bit 7    | PLL_MDIV_Doubler | PLL reference divider - doubler   | R/W  | disable | enable             | 0   |
| Bit 6    | PLL IREF         | PLL CP reference current          | R/W  | 1X      | 2X                 | 1   |
| Bit 5    | PLL_SSEN         | PLL spread spectrum enable        | R/W  | disable | enable             | 0   |
| Bit 4    | PLL_R100K        | PLL Loop filter resistor 100kOhm  | R/W  | bypass  | plus 100kOhm       | 0   |
| Bit 3    | PLL_R50K         | PLL Loop filter resistor 50kOhm   | R/W  | bypass  | plus 50kOhm        | 0   |
| Bit 2    | PLL_R25K         | PLL Loop filter resistor 25kOhm   | R/W  | bypass  | plus 25kOhm        | 0   |
| Bit 1    | PLL_R12.5K       | PLL Loop filter resistor 12.5kOhm | R/W  | bypass  | plus 12.5kOhm      | 0   |
| Bit 0    | PLL_R1K          | PLL Loop filter resistor 1kOhm    | R/W  | bypass  | only 1kOhm applied | 1   |

**Byte 12: PLL Loop R Setting (Apply to 5X1503/5X1503L)**

| Byte 0Ch | Name             | Control Function                  | Type | 0       | 1             | PWD |
|----------|------------------|-----------------------------------|------|---------|---------------|-----|
| Bit 7    | PLL_MDIV_Doubler | PLL reference divider - doubler   | R/W  | disable | enable        | 0   |
| Bit 6    | PLL IREF         | PLL CP reference current          | R/W  | 1X      | 2X            | 0   |
| Bit 5    | PLL_SSEN         | PLL spread spectrum enable        | R/W  | disable | enable        | 0   |
| Bit 4    | PLL_R100K        | PLL Loop filter resistor 100kOhm  | R/W  | bypass  | plus 100kOhm  | 0   |
| Bit 3    | PLL_R75K         | PLL Loop filter resistor 75kOhm   | R/W  | bypass  | plus 75kOhm   | 0   |
| Bit 2    | PLL_R50K         | PLL Loop filter resistor 50kOhm   | R/W  | bypass  | plus 50kOhm   | 0   |
| Bit 1    | PLL_R25K         | PLL Loop filter resistor 25kOhm   | R/W  | bypass  | plus 25kOhm   | 1   |
| Bit 0    | PLL_R12.5K       | PLL Loop filter resistor 12.5kOhm | R/W  | bypass  | plus 12.5kOhm | 1   |

**Byte 13: PLL Charge Pump Control (Apply to 5X1503S)**

| Byte 0Dh | Name       | Control Function        | Type | 0 | 1   | PWD |
|----------|------------|-------------------------|------|---|-----|-----|
| Bit 7    | PLL_CP_31X | PLL charge pump control | R/W  | — | x31 | 1   |
| Bit 6    | PLL_CP_16X | PLL charge pump control | R/W  | — | x16 | 0   |
| Bit 5    | PLL_CP_8X  | PLL charge pump control | R/W  | — | x8  | 1   |
| Bit 4    | PLL_CP_4X  | PLL charge pump control | R/W  | — | x4  | 1   |
| Bit 3    | PLL_CP_2X  | PLL charge pump control | R/W  | — | x2  | 1   |
| Bit 2    | PLL_CP_1X  | PLL charge pump control | R/W  | — | x1  | 0   |
| Bit 1    | PLL_CP_/24 | PLL charge pump control | R/W  | — | /24 | 0   |
| Bit 0    | PLL_CP_/3  | PLL charge pump control | R/W  | — | /3  | 1   |

**Byte 13: PLL Charge Pump Control (Apply to 5X1503/5X1503L)**

| Byte 0Dh | Name       | Control Function        | Type | 0 | 1   | PWD |
|----------|------------|-------------------------|------|---|-----|-----|
| Bit 7    | PLL_CP_31X | PLL charge pump control | R/W  | — | x31 | 0   |
| Bit 6    | PLL_CP_16X | PLL charge pump control | R/W  | — | x16 | 0   |
| Bit 5    | PLL_CP_8X  | PLL charge pump control | R/W  | — | x8  | 0   |
| Bit 4    | PLL_CP_4X  | PLL charge pump control | R/W  | — | x4  | 1   |
| Bit 3    | PLL_CP_2X  | PLL charge pump control | R/W  | — | x2  | 0   |
| Bit 2    | PLL_CP_1X  | PLL charge pump control | R/W  | — | x1  | 1   |
| Bit 1    | PLL_CP_/24 | PLL charge pump control | R/W  | — | /24 | 1   |
| Bit 0    | PLL_CP_/3  | PLL charge pump control | R/W  | — | /3  | 0   |

**Byte 14: Output Divider1 Control (Apply to 5X1503S)**

| Byte 0Eh | Name                  | Control Function              | Type | 0   | 1                      | PWD |
|----------|-----------------------|-------------------------------|------|---|------------------------|-----|
| Bit 7    | OUTDIV1[4]            | Output divider1 control bit 4 | R/W  | DIV1[3:2] = 1,3,5,7,9,11;<br>DIV1[1:0] = 1,2,4,8;<br>DefaultDivider=00001=3 |                        | 0   |
| Bit 6    | OUTDIV1[3]            | Output divider1 control bit 3 | R/W  |   |                        | 1   |
| Bit 5    | OUTDIV1[2]            | Output divider1 control bit 2 | R/W  |   |                        | 0   |
| Bit 4    | OUTDIV1[1]            | Output divider1 control bit 1 | R/W  |   |                        | 1   |
| Bit 3    | OUTDIV1[0]            | Output divider1 control bit 0 | R/W  |   |                        | 0   |
| Bit 2    | OUTDIV2 Source Select | OUTDIV2 Source Select         | R/W  | From REF  | OUTDIV2_Source         | 0   |
| Bit 1    | OUTDIV1 Source Select | OUTDIV1 Source Select         | R/W  | From REF  | From PLL               | 1   |
| Bit 0    | OUTDIV1 Seed          | OUTDIV1 Seed                  | R/W  | disabled  | enable seed to OUTDIV2 | 0   |

**Byte 14: Output Divider1 Control (Apply to 5X1503/5X1503L)**

| Byte 0Eh | Name                  | Control Function              | Type | 0   | 1                      | PWD |
|----------|-----------------------|-------------------------------|------|---|------------------------|-----|
| Bit 7    | OUTDIV1[4]            | Output divider1 control bit 4 | R/W  | DIV1[3:2] = 1,3,5,7,9,11;<br>DIV1[1:0] = 1,2,4,8;<br>DefaultDivider=00001=3 |                        | 0   |
| Bit 6    | OUTDIV1[3]            | Output divider1 control bit 3 | R/W  |   |                        | 0   |
| Bit 5    | OUTDIV1[2]            | Output divider1 control bit 2 | R/W  |   |                        | 0   |
| Bit 4    | OUTDIV1[1]            | Output divider1 control bit 1 | R/W  |   |                        | 0   |
| Bit 3    | OUTDIV1[0]            | Output divider1 control bit 0 | R/W  |   |                        | 1   |
| Bit 2    | OUTDIV2 Source Select | OUTDIV2 Source Select         | R/W  | From REF  | OUTDIV2_Source         | 0   |
| Bit 1    | OUTDIV1 Source Select | OUTDIV1 Source Select         | R/W  | From REF  | From PLL               | 1   |
| Bit 0    | OUTDIV1 Seed          | OUTDIV1 Seed                  | R/W  | disabled  | enable seed to OUTDIV2 | 0   |

### Byte 15: Output Divider 2 Control

| Byte 0Fh | Name         | Control Function              | Type | 0   | 1        | PWD |
|----------|--------------|-------------------------------|------|---|----------|-----|
| Bit 7    | OUTDIV2[4]   | Output divider2 control bit 4 | R/W  | DIV1[3:2] = 1, 3, 5, 7, 9, 11;<br>DIV1[1:0] = 1, 2, 4, 8;<br>DefaultDivider=00001=3 |          | 0   |
| Bit 6    | OUTDIV2[3]   | Output divider2 control bit 3 | R/W  |   |          | 0   |
| Bit 5    | OUTDIV2[2]   | Output divider2 control bit 2 | R/W  |   |          | 0   |
| Bit 4    | OUTDIV2[1]   | Output divider2 control bit 1 | R/W  |   |          | 0   |
| Bit 3    | OUTDIV2[0]   | Output divider2 control bit 0 | R/W  |   |          | 1   |
| Bit 2    | OUT3_OUT_TRI | OUT3 State Select             | R/W  | normal  | Tristate | 0   |
| Bit 1    | OUT2_OUT_TRI | OUT2 State Select             | R/W  | normal  | Tristate | 0   |
| Bit 0    | OUT1_OUT_TRI | OUT1 State Select             | R/W  | normal  | Tristate | 0   |

### Byte 16: PLL Operation Control Register

| Byte 10h | Name           | Control Function                 | Type | 0                          | 1                           | PWD |
|----------|----------------|----------------------------------|------|----------------------------|-----------------------------|-----|
| Bit 7    | OUT1_EN        | OUT1 output enable control       | R/W  | disable                    | enable                      | 1   |
| Bit 6    | OE1_fun_sel[1] | OE1 pin function selection bit 1 | R/W  | 11: DFC0<br>01: PD#        | 10: OUT1_PPS<br>00: OUT1 OE | 0   |
| Bit 5    | OE1_fun_sel[0] | OE1 pin function selection bit 0 | R/W  |                            |                             | 0   |
| Bit 4    | OUT2_EN        | OUT2 output enable control       | R/W  | disable                    | enable                      | 1   |
| Bit 3    | OE2_fun_sel[1] | OE2 pin function selection bit 1 | R/W  | 11: DFC1<br>01: Config_SEL | 10: OUT2_PPS<br>00: OUT2 OE | 0   |
| Bit 2    | OE2_fun_sel[0] | OE2 pin function selection bit 0 | R/W  |                            |                             | 0   |
| Bit 1    | OUT2 Freerun   | OUT2 Freerun enable control      | R/W  | Freerun                    | normal                      | 1   |
| Bit 0    | OUT1 Freerun   | OUT1 Freerun enable control      | R/W  | Freerun                    | normal                      | 0   |

### Byte 17: OE and DFC Control

| Byte 11h | Name          | Control Function            | Type | 0   | 1      | PWD |
|----------|---------------|-----------------------------|------|---|--------|-----|
| Bit 7    | OUT1 CLKSEL 1 | OUT1 output clock selection | R/W  | 00: CLK32K, 01: OUTDIV2<br>10: NA, 11: OUTDIV1  |        | 0   |
| Bit 6    | OUT1 CLKSEL 0 | OUT1 output clock selection | R/W  |   |        | 0   |
| Bit 5    | OUT2 CLKSEL 1 | OUT2 output clock selection | R/W  | 00: CLK32K, 01: OUTDIV2<br>10: NA, 11: OUTDIV1  |        | 1   |
| Bit 4    | OUT2 CLKSEL 0 | OUT2 output clock selection | R/W  |   |        | 1   |
| Bit 3    | OUT3 CLKSEL 1 | OUT3 output clock selection | R/W  | 00: CLK32K, 01: OUTDIV2<br>10: REF, 11: OUTDIV1 |        | 1   |
| Bit 2    | OUT3 CLKSEL 0 | OUT3 output clock selection | R/W  |   |        | 0   |
| Bit 1    | OUT3_EN       | OUT3 output enable control  | R/W  | disable   | enable | 1   |
| Bit 0    | DFC_EN        | DFC function control        | R/W  | disable   | enable | 0   |



### Byte 18: Control Register

| Byte 12h | Name              | Control Function                     | Type | 0  | 1             | PWD |
|----------|-------------------|--------------------------------------|------|--|---------------|-----|
| Bit 7    | PLL PDB           | PLL Powerdown enable control         | R/W  | Powerdown                                  | Not powerdown | 1   |
| Bit 6    | PLL LOCKBYPASS    | PLL Lock Bypass enable control       | R/W  | Bypass                                     | Not Bypass    | 1   |
| Bit 5    | SCL HW Mode Sel   | SCL in hardware mode function select | R/W  | N/A  | DFC1          | 0   |
| Bit 4    | PPS PDB EN        | PPS PDB enable control               | R/W  | disable                                    | enable        | 0   |
| Bit 3    | PPS2 Timer_sel<1> | PPS2 Timer select bit 1              | R/W  | 00: 100µs 01: 200µs<br>10: 400µs 11: 800µs |               | 0   |
| Bit 2    | PPS2 Timer_sel<0> | PPS2 Timer select bit 0              | R/W  |  |               | 0   |
| Bit 1    | PPS1 Timer_sel<1> | PPS1 Timer select bit 1              | R/W  | 00: 100µs 01: 200µs<br>10: 400µs 11: 800µs |               | 0   |
| Bit 0    | PPS1 Timer_sel<0> | PPS1 Timer select bit 0              | R/W  |  |               | 0   |

### Byte 19: Control Register

| Byte 13h | Name            | Control Function              | Type | 0                                      | 1      | PWD |
|----------|-----------------|-------------------------------|------|--|--------|-----|
| Bit 7    | OUT1 CLK Invert | OUT1 CLK Invert control       | R/W  | Non-Invert                             | Invert | 0   |
| Bit 6    | OUT2 CLK Invert | OUT2 CLK Invert control       | R/W  | Non-Invert                             | Invert | 0   |
| Bit 5    | OUT3 CLK Invert | OUT3 CLK Invert control       | R/W  | Non-Invert                             | Invert | 0   |
| Bit 4    | OUT3 Freerun    | OUT3 Freerun enable control   | R/W  | Freerun                                | normal | 1   |
| Bit 3    | OUT2 Amp OUT 1  | OUT2 Amplitude Select control | R/W  | 00: 1.8V 01: 1.0V<br>10: 1.1V 11: 1.0V |        | 0   |
| Bit 2    | OUT2 Amp OUT 0  | OUT2 Amplitude Select control | R/W  |  |        | 0   |
| Bit 1    | OUT3 Amp OUT 1  | OUT3 Amplitude Select control | R/W  | 00: 1.8V 01: 1.0V<br>10: 1.1V 11: 1.0V |        | 0   |
| Bit 0    | OUT3 Amp OUT 0  | OUT3 Amplitude Select control | R/W  |  |        | 0   |

### Byte 20: OUT1 and DIV4 Control (Apply to 5X1503/5X1503S)

| Byte 14h | Name                   | Control Function                   | Type | 0             | 1               | PWD |
|----------|------------------------|------------------------------------|------|---------------|-----------------|-----|
| Bit 7    | I2C_PDB                | chip power down control bit        | R/W  | power down    | normal          | 1   |
| Bit 6    | Ref_free_run           | Reference clock output (OUT2/OUT3) | R/W  | stop          | freerun         | 0   |
| Bit 5    | free_run_output_config | OUT clocks free run control        | R/W  | OUT2 free run | OUT2/3 free run | 0   |
| Bit 4    | PDB Invert             | PDB polarity control bit           | R/W  | Non-Invert    | Invert          | 0   |
| Bit 3    | BYP_AC                 | Bypass AC cap in X1 (5X1503 only)  | R/W  | normal        | Bypass          | 0   |
| Bit 2    | Reserved               |                                    | R/W  | —             | —               | 0   |
| Bit 1    | Reserved               |                                    | R/W  | —             | —               | 1   |
| Bit 0    | Reserved               |                                    | R/W  | —             | —               | 1   |

### Byte 20: OUT1 and DIV4 Control (Apply to 5X1503L)

| Byte 14h | Name                             | Control Function                       | Type | 0   | 1               | PWD |
|----------|----------------------------------|--|------|---|-----------------|-----|
| Bit 7    | I2C_PDB                          | chip power down control bit            | R/W  | power down  | normal          | 1   |
| Bit 6    | Ref_free_run                     | Reference clock output (OUT2/OUT3)     | R/W  | stop  | freerun         | 0   |
| Bit 5    | free_run_output_config           | OUT clocks free run control            | R/W  | OUT2 free run   | OUT2/3 free run | 0   |
| Bit 4    | PDB Invert                       | PDB polarity control bit               | R/W  | Non-Invert  | Invert          | 0   |
| Bit 3    | BYP_AC                           | Bypass AC cap in X1                    | R/W  | normal  | Bypass          | 0   |
| Bit 2    | CLK32K Low Drive Amp Select<2:0> | CLK32K Low Drive Amplitude Select<2:0> | R/W  | 000: 1.8V 001: 0.8V 010: 0.9V<br>011: 1.0V 100: 1.1V 101:1.2V |                 | 0   |
| Bit 1    |                                  |  | R/W  |   |                 | 1   |
| Bit 0    |                                  |  | R/W  |   |                 | 1   |

## Glossary of Features

Table 17. Glossary of Features

| Term        | Function Description   | Apply to |
|-------------|--|----------|
| DFC         | Dynamic Frequency Control from selected PLL (TBD) to support two VCO frequencies—two different output frequencies by assigning H/W pin state changes (H-L or L-H). Needs to have frequency change Glitch-free function in order to not crash application system. | All      |
| ORT         | Overshoot Reduction Technology—when the PLL performs VCO frequency changes by DFC, or manually programming, the VCO changes frequencies smoothly to target frequency without overshoot or undershoot.  | All      |
| OE          | Output Enable function. High active. Each output can be controlled by assigned OE pin and the dedicated OE pin can be OTP programmable as Global Power Down function (PD#) or Output enable (OE) or proactive power saving function (PPS).                       | All      |
| PCT         | Programmable Calibration Time, for 32K DCO, the programmable calibration time will help power saving or output accuracy adjustments.   | All      |
| Glitch-free | The output clock should not have short pulses that will kill the application system, the output frequency switch (based on DFC) should has glitch free function.   | All      |
| SS          | Spread Spectrum Clock  | 5X1503S  |
| PPS         | Proactive Power Saving. Utilizes OE pin as monitor pin for end device X2 clock status. See <a href="#">PPS – Proactive Power Saving Function</a> description for details.  | All      |

## Package Outline Drawings

The package outline drawings are appended at the end of this document and are accessible from the link below. The package information is the most current data available.

[www.idt.com/document/psc/10-vfqfpn-package-outline-drawing-20-x-20-x-10-mm-body-epad-16-x-08-mm-04mm-pitch-nlg10p1](http://www.idt.com/document/psc/10-vfqfpn-package-outline-drawing-20-x-20-x-10-mm-body-epad-16-x-08-mm-04mm-pitch-nlg10p1)

## Ordering Information

| Orderable Part Number | Package                      | Shipping Packaging | Temperature   |
|-----------------------|------------------------------|--------------------|---------------|
| 5X1503-xxxNLGI        | 2.0 × 2.0 × 1.0 mm 10-VFQFPN | Tray               | -40° to +85°C |
| 5X1503-xxxNLGI8       | 2.0 × 2.0 × 1.0 mm 10-VFQFPN | Reel               | -40° to +85°C |
| 5X1503L-xxxNLGI       | 2.0 × 2.0 × 1.0 mm 10-VFQFPN | Tray               | -40° to +85°C |
| 5X1503L-xxxNLGI8      | 2.0 × 2.0 × 1.0 mm 10-VFQFPN | Reel               | -40° to +85°C |
| 5X1503S-xxxNLGI       | 2.0 × 2.0 × 1.0 mm 10-VFQFPN | Tray               | -40° to +85°C |
| 5X1503S-xxxNLGI8      | 2.0 × 2.0 × 1.0 mm 10-VFQFPN | Reel               | -40° to +85°C |

## Marking Diagrams

### 5X1503

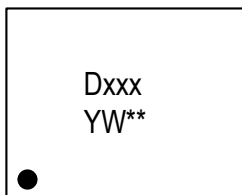

- Line 1 is the truncated part number and indicates the following:
  - “D” denotes 5X1503; “xxx” denotes dash code.
  - “E” denotes 5X1503L; “xxx” denotes dash code.
  - “F” denotes 5X1503S; “xxx” denotes dash code.
- Line 2 indicates the following:
  - “YW” is the last digit of the year and work week the part was assembled.
  - “\*\*” denotes sequential lot number.

### 5X1503L

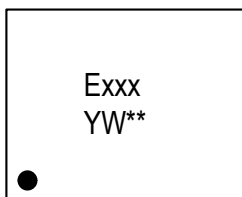

### 5X1503S

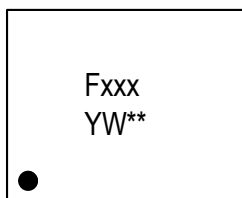

## Revision History

| Revision Date | Description of Change |
|---------------|-----------------------|
| June 19, 2019 | Initial release.      |

## IMPORTANT NOTICE AND DISCLAIMER

RENESAS ELECTRONICS CORPORATION AND ITS SUBSIDIARIES (“RENESAS”) PROVIDES TECHNICAL SPECIFICATIONS AND RELIABILITY DATA (INCLUDING DATASHEETS), DESIGN RESOURCES (INCLUDING REFERENCE DESIGNS), APPLICATION OR OTHER DESIGN ADVICE, WEB TOOLS, SAFETY INFORMATION, AND OTHER RESOURCES “AS IS” AND WITH ALL FAULTS, AND DISCLAIMS ALL WARRANTIES, EXPRESS OR IMPLIED, INCLUDING, WITHOUT LIMITATION, ANY IMPLIED WARRANTIES OF MERCHANTABILITY, FITNESS FOR A PARTICULAR PURPOSE, OR NON-INFRINGEMENT OF THIRD PARTY INTELLECTUAL PROPERTY RIGHTS.

These resources are intended for developers skilled in the art designing with Renesas products. You are solely responsible for (1) selecting the appropriate products for your application, (2) designing, validating, and testing your application, and (3) ensuring your application meets applicable standards, and any other safety, security, or other requirements. These resources are subject to change without notice. Renesas grants you permission to use these resources only for development of an application that uses Renesas products. Other reproduction or use of these resources is strictly prohibited. No license is granted to any other Renesas intellectual property or to any third party intellectual property. Renesas disclaims responsibility for, and you will fully indemnify Renesas and its representatives against, any claims, damages, costs, losses, or liabilities arising out of your use of these resources. Renesas' products are provided only subject to Renesas' Terms and Conditions of Sale or other applicable terms agreed to in writing. No use of any Renesas resources expands or otherwise alters any applicable warranties or warranty disclaimers for these products.

(Rev.1.0 Mar 2020)

### Corporate Headquarters

TOYOSU FORESIA, 3-2-24 Toyosu,  
Koto-ku, Tokyo 135-0061, Japan  
[www.renesas.com](http://www.renesas.com)

### Contact Information

For further information on a product, technology, the most up-to-date version of a document, or your nearest sales office, please visit:  
[www.renesas.com/contact/](http://www.renesas.com/contact/)

### Trademarks

Renesas and the Renesas logo are trademarks of Renesas Electronics Corporation. All trademarks and registered trademarks are the property of their respective owners.

## X-ON Electronics

Largest Supplier of Electrical and Electronic Components

*Click to view similar products for [Clock & Timer Development Tools](#) category:*

*Click to view products by [Renesas](#) manufacturer:*

Other Similar products are found below :

[AD9517-0A/PCBZ](#) [AD9517-2A/PCBZ](#) [AD9522-4/PCBZ](#) [AD9520-5PCBZ](#) [AD9530/PCBZ](#) [AD9553/PCBZ](#) [ADCLK914PCBZ](#)  
[LMH2180SDEVAL](#) [DSC400-0333Q0032KE1-EVB](#) [TDGL013](#) [MAX2880EVKIT#](#) [MAX2750EVKIT](#) [MAX2752EVKIT](#) [ADCLK946PCBZ](#)  
[ADCLK946/PCBZ](#) [MAX2622EVKIT](#) [EKIT01-HMC1032LP6G](#) [Si5332-8IX-EVB](#) [Si5332-12IX-EVB](#) [RV-3029-C2-EVALUATION-BOARD-](#)  
[OPTION-B](#) [Si5332-6IX-EVB](#) [SKY72310-11-EVB](#) [EV1HMC8364LP6G](#) [RV-8263-C7-EVALUATION-BOARD](#) [EVK9FGV1002](#)  
[EVK9FGV1008](#) [EV1HMC6832ALP5L](#) [EVAL01-HMC830LP6GE](#) [EVAL01-HMC911LC4B](#) [EVAL01-HMC988LP3E](#) [TS3002DB](#) [125605-](#)  
[HMC702LP6CE](#) [LMX2487E-EVM](#) [MIKROE-2481](#) [2045](#) [EKIT01-HMC835LP6G](#) [EKIT01-HMC834LP6GE](#) [TS3006DB](#) [DSC-](#)  
[TIMEFLASH2-KIT1](#) [110227-HMC510LP5](#) [110227-HMC513LP5](#) [AD9515/PCBZ](#) [ADCLK948/PCBZ](#) [ADCLK954/PCBZ](#) [112261-](#)  
[HMC739LP4](#) [ADCLK925/PCBZ](#) [AD9522-0/PCBZ](#) [AD9520-4/PCBZ](#) [AC164147](#) [DFR0469](#)