

ICL3238E

±15kV ESD Protected, +3V to +5.5V, 10nA, 250kbps, RS-232 Transceiver with Enhanced Automatic Powerdown

The [ICL3238E](#) contains 3.0V to 5.5V powered RS-232 transmitters/receivers that meet EIA/TIA-232 and V.28/V.24 specifications, even at $V_{CC} = 3.0V$. It provides ±15kV ESD protection (IEC61000-4-2 Air Gap and Human Body Model) on transmitter outputs and receiver inputs (RS-232 pins). Targeted applications are cell phones, Palmtops, and data cables in which the low operational power consumption and even lower standby power consumption is critical. Efficient on-chip charge pumps coupled with manual and enhanced automatic powerdown functions reduce the standby supply current to a 10nA trickle. Small footprint packaging and the use of small, low value capacitors ensure board space savings. Data rates greater than 250kbps are ensured at worst-case load conditions and provide compatibility with popular PC communication software.

The ICL3238E is a five driver, three receiver device optimized for DCE applications with full hardware handshaking. It includes a noninverting, always-active receiver for RING INDICATOR monitoring.

The ICL3238E features an enhanced automatic powerdown function that powers down the on-chip power-supply and driver circuits. Automatic powerdown occurs when all receiver and transmitter inputs detect no signal transitions for a period of 30s. The ICL3238E automatically powers back up whenever it senses a transition on any transmitter or receiver input.

The transmitter and logic inputs include active feedback resistors that retain the input state when driven to a valid logic level.

[Table 1](#) summarizes the features of the ICL3238E. [Application Note AN9863](#) summarizes the features of each device in the ICL32xxE 3V RS-232 family.

Related Literature

For a full list of related documents, visit our website:

- [ICL3238E](#) device page

Features

- Pb-free (RoHS compliant)
- ESD protection for RS-232 I/O pins to ±15kV (IEC61000)
- Active feedback resistors on T_X and logic inputs
- Manual and enhanced automatic powerdown features
- Pin compatible replacement for MAX3238E, MAX3238, and SP3238E
- Meets EIA/TIA-232 and V.28/V.24 specifications at 3V
- RS-232 compatible outputs at 2.7V supply
- Flow through pinout
- Latch-up free
- On-chip voltage converters require only four external capacitors
- Receiver and transmitter hysteresis for improved noise immunity
- Guaranteed minimum data rate: 250kbps
- Guaranteed minimum slew rate: 6V/μs
- Wide power supply range: Single +3V to +5.5V
- Low supply current in powerdown state: 10nA

Applications

- Any system requiring RS-232 communication ports
 - Battery powered, hand-held, and portable equipment
 - Data cradles
 - Modems, printers, and other peripherals
 - Cellular/mobile phones and data cables

Table 1. Summary of Features

Part Number	No. of Tx.	No. of Rx.	No. of Monitor Rx. (R_{OUTB})	Data Rate (kbps)	Rx. Enable Function?	Ready Output?	Manual Powerdown?	Enhanced Automatic Powerdown Function?
ICL3238E	5	3	1	250	No	No	Yes	Yes

Contents

1. Overview	3
1.1 Typical Operating Circuit	3
1.2 Ordering Information	3
1.3 Pin Configuration	4
1.4 Pin Descriptions	4
2. Specifications	6
2.1 Absolute Maximum Ratings	6
2.2 Thermal Information	6
2.3 Recommended Operating Conditions	6
2.4 Electrical Specifications	7
3. Typical Performance Curves	9
4. Application Information	10
4.1 Charge Pump	10
4.1.1 Charge Pump Abs Max Ratings	10
4.2 Transmitters	11
4.3 Receivers	11
4.4 Operation Down to 2.7V	13
4.5 Powerdown Functionality	13
4.5.1 Software Controlled (Manual) Powerdown	13
4.5.2 INVALID Output	13
4.5.3 Enhanced Automatic Powerdown	15
4.5.4 Emulating Standard Automatic Powerdown	16
4.5.5 Hybrid Automatic Powerdown Options	16
4.6 Capacitor Selection	16
4.7 Power Supply Decoupling	17
4.8 Transmitter Outputs when Exiting Powerdown	17
4.9 High Data Rates	18
4.10 Interconnection with 3V and 5V Logic	18
5. ±15kV ESD Protection	19
5.1 Human Body Model (HBM) Testing	19
5.2 IEC61000-4-2 Testing	19
5.3 Air-Gap Discharge Test Method	19
5.4 Contact Discharge Test Method	19
6. Die Characteristics	20
7. Revision History	21
8. Package Outline Drawings	22

Part Number (Notes 4, 5)	Part Marking	Temp Range (°C)	Tape and Reel (Units) (Note 3)	Package (RoHS Compliant)	Pkg. Dwg. #
ICL3238EIVZ	ICL3238 EIVZ	-40 to +85	-	28 Ld TSSOP	M28.173
ICL3238EIVZ-T	ICL3238 EIVZ	-40 to +85	2.5k	28 Ld TSSOP	M28.173

Notes:

- See [TB347](#) for details about reel specifications.
- These Pb-free plastic packaged products employ special Pb-free material sets; molding compounds/die attach materials and NiPdAu-Ag plate - e4 termination finish, which is RoHS compliant and compatible with both SnPb and Pb-free soldering operations. Pb-free products are MSL classified at Pb-free peak reflow temperatures that meet or exceed the Pb-free requirements of IPC/JEDEC J STD-020.
- For Moisture Sensitivity Level (MSL), see the [ICL3238E](#) device page. For more information about MSL, see [TB363](#).

1.3 Pin Configuration

28 Ld SSOP, 28 Ld TSSOP
Top View

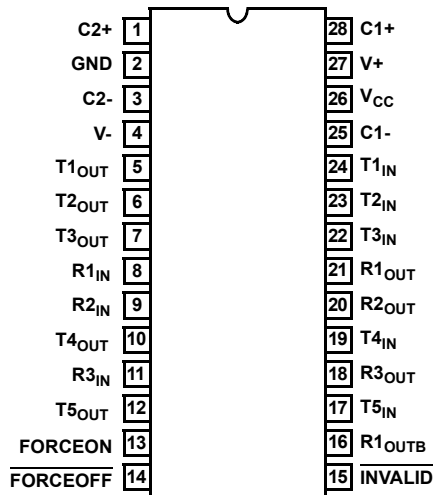

1.4 Pin Descriptions

Pin	Function
V _{CC}	System power supply input (3.0V to 5.5V).
V+	Internally generated positive transmitter supply (+5.5V).
V-	Internally generated negative transmitter supply (-5.5V).
GND	Ground connection.
C1+	External capacitor (voltage doubler) is connected to this lead.
C1-	External capacitor (voltage doubler) is connected to this lead.
C2+	External capacitor (voltage inverter) is connected to this lead.
C2-	External capacitor (voltage inverter) is connected to this lead.
T _{XIN}	TTL/CMOS compatible transmitter inputs (Note 6).
T _{XOUT}	±15kV ESD protected, RS-232 level (nominally ±5.5V) transmitter outputs.
R _{XIN}	±15kV ESD protected, RS-232 compatible receiver inputs.
R _{XOUT}	TTL/CMOS level receiver outputs.
R _{XOUTB}	TTL/CMOS level, noninverting, always enabled receiver outputs.
INVALID	Active low output that indicates if no valid RS-232 levels are present on any receiver input.

Pin	Function
$\overline{\text{FORCEOFF}}$	Active low to shut down transmitters and on-chip power supply. This pin overrides any automatic circuitry and FORCEON (see Table 5 , Note 6).
FORCEON	Active high input to override automatic powerdown circuitry, which keeps transmitters active ($\overline{\text{FORCEOFF}}$ must be high, Note 6).

Note:

6. These input pins incorporate positive feedback resistors. When the input is driven to a valid logic level, the feedback resistor maintains that logic level until V_{CC} is removed. Unused transmitter inputs can remain unconnected.

2. Specifications

2.1 Absolute Maximum Ratings

Parameter	Minimum	Maximum	Unit
V _{CC} to GND	-0.3	+6	V
V+ to GND	-0.3	+7	V
V- to GND	+0.3	-7	V
V+ to V-		+14	V
Input Voltages			
T _{IN} , FORCEOFF, FORCEON	-0.3	+6	V
R _{IN}		±25	V
Output Voltages			
T _{OUT}		±13.2	V
R _{OUT} , INVALID	-0.3	V _{CC} + 0.3	V
Short-Circuit Duration			
T _{OUT}		Continuous	
ESD Rating	See ESD Performance		

CAUTION: Do not operate at or near the maximum ratings listed for extended periods of time. Exposure to such conditions can adversely impact product reliability and result in failures not covered by warranty.

2.2 Thermal Information

Thermal Resistance (Typical) (Note 7)	θ_{JA} (°C/W)
28 Ld TSSOP Package	100
28 Ld SSOP Package	110

Note:

- θ_{JA} is measured with the component mounted on a low-effective thermal conductivity test board in free air. See [TB379](#) for details.

Parameter	Minimum	Maximum	Unit
Maximum Junction Temperature (Plastic Package)		+150	°C
Maximum Storage Temperature Range	-65	+150	°C
Pb-Free Reflow Profile	see TB493		

2.3 Recommended Operating Conditions

Parameter	Minimum	Maximum	Unit
Temperature Range			
ICL3238ECx	0	+70	°C
ICL3238EIx	-40	+85	°C

2.4 Electrical Specifications

Test conditions: $V_{CC} = 3.15V$ to $5.5V$, $C_1 - C_4 = 0.1\mu F$; $V_{CC} = 3V$, $C_1 - C_4 = 0.22\mu F$; unless otherwise specified. Typical values are at $T_A = 25^\circ C$

Parameter	Test Conditions	Temp (°C)	Min	Typ	Max	Unit	
DC Characteristics							
Supply Current, Automatic Powerdown	All R_{IN} Open, FORCEON = GND, $\overline{FORCEOFF} = V_{CC}$	25	-	10	300	nA	
Supply Current, Powerdown	$\overline{FORCEOFF} = GND$	25	-	10	300	nA	
Supply Current, Automatic Powerdown Disabled	All Outputs Unloaded, FORCEON = $\overline{FORCEOFF} = V_{CC}$	25	-	0.3	1.0	mA	
Logic and Transmitter Inputs and Receiver Outputs							
Input Logic Threshold Low	T_{IN} Active	Full	-	-	0.8	V	
	T_{IN} , FORCEON, $\overline{FORCEOFF}$ Wake up Threshold	$V_{CC} = 3.3V$	Full	-	-	0.8	V
		$V_{CC} = 5.0V$	Full	-	-	0.8	V
Input Logic Threshold High	T_{IN} Active	$V_{CC} = 3.6V$	Full	2.0	-	-	V
	T_{IN} , FORCEON, $\overline{FORCEOFF}$ Wake up Threshold	$V_{CC} = 3.3V$	Full	2.0	-	-	V
		$V_{CC} = 5.0V$	Full	2.4	-	-	V
Input Leakage Current	T_{IN} , FORCEON, $\overline{FORCEOFF}$, $V_{IN} = 0V$ or V_{CC} (Note 8)	Full	-	± 0.01	± 1.0	μA	
Output Leakage Current	$\overline{FORCEOFF} = GND$	Full	-	± 0.05	± 10	μA	
Output Voltage Low	$I_{OUT} = 1.0mA$	Full	-	-	0.4	V	
Output Voltage High	$I_{OUT} = -1.0mA$	Full	$V_{CC} - 0.6$	$V_{CC} - 0.1$	-	V	
Receiver Inputs							
Input Voltage Range		Full	-25	-	25	V	
Input Threshold Low	$V_{CC} = 3.3V$	Full	0.6	1.2	-	V	
	$V_{CC} = 5.0V$	Full	0.8	1.5	-	V	
Input Threshold High	$V_{CC} = 3.3V$	Full	-	1.5	2.4	V	
	$V_{CC} = 5.0V$	Full	-	1.8	2.4	V	
Input Hysteresis		25	-	0.6	-	V	
Input Resistance		25	3	5	7	k Ω	
Enhanced Automatic Powerdown (FORCEON = GND, $\overline{FORCEOFF} = V_{CC}$)							
Receiver Input Thresholds to $\overline{INVALID}$ High	(Figure 8)	Full	-2.7	-	2.7	V	
Receiver Input Thresholds to $\overline{INVALID}$ Low	(Figure 8)	Full	-0.3	-	0.3	V	
$\overline{INVALID}$ Output Voltage Low	$I_{OUT} = 1.0mA$	Full	-	-	0.4	V	
$\overline{INVALID}$ Output Voltage High	$I_{OUT} = -1.0mA$	Full	$V_{CC} - 0.6$	-	-	V	
Receiver Positive or Negative Threshold to $\overline{INVALID}$ High Delay (t_{INVH})		25	-	0.3	-	μs	
Receiver Positive or Negative Threshold to $\overline{INVALID}$ Low Delay (t_{INVL})		25	-	60	-	μs	
Receiver or Transmitter Edge to Transmitters Enabled Delay (t_{WU})	(Note 9)	25	-	25	-	μs	
Receiver or Transmitter Edge to Transmitters Disabled Delay ($t_{AUTOPWDN}$)	(Note 9)	Full	15	30	60	s	

Test conditions: $V_{CC} = 3.15V$ to $5.5V$, $C_1 - C_4 = 0.1\mu F$; $V_{CC} = 3V$, $C_1 - C_4 = 0.22\mu F$; unless otherwise specified. Typical values are at $T_A = 25^\circ C$

Parameter	Test Conditions	Temp (°C)	Min	Typ	Max	Unit	
Transmitter Outputs							
Output Voltage Swing	All Transmitter Outputs Loaded with $3k\Omega$ to Ground	Full	± 5.0	± 5.4	-	V	
Output Resistance	$V_{CC} = V_+ = V_- = 0V$, Transmitter Output = $\pm 2V$	Full	300	10M	-	Ω	
Output Short-Circuit Current		Full	-	± 35	± 60	mA	
Output Leakage Current	$V_{OUT} = \pm 12V$, $V_{CC} = 0V$ or $3V$ to $5.5V$, Automatic Powerdown or $\overline{FORCEOFF} = GND$	Full	-	-	± 25	μA	
Timing Characteristics							
Maximum Data Rate	$R_L = 3k\Omega$, $C_L = 1000pF$, One Transmitter Switching	Full	250	500	-	kbps	
Receiver Propagation Delay	Receiver Input to Receiver Output, $C_L = 150pF$	t_{PHL}	25	-	0.15	-	μs
		t_{PLH}	25	-	0.15	-	μs
Receiver Output Enable Time	Normal Operation	25	-	150	-	ns	
Receiver Output Disable Time	Normal Operation	25	-	300	-	ns	
Transmitter Skew	$t_{PHL} - t_{PLH}$	25	-	50	-	ns	
Receiver Skew	$t_{PHL} - t_{PLH}$	25	-	50	-	ns	
Transition Region Slew Rate	$V_{CC} = 3.3V$, $R_L = 3k\Omega$ to $7k\Omega$, Measured From $3V$ to $-3V$ or $-3V$ to $3V$	$C_L = 150pF$ to $1000pF$	25	6	15	30	V/ μs
		$C_L = 150pF$ to $2500pF$	25	4	12	30	V/ μs
ESD Performance							
RS-232 Pins (T_{OUT} , R_{IN})	IEC61000-4-2 Air Gap Discharge	25	-	± 15	-	kV	
	IEC61000-4-2 Contact Discharge	25	-	± 8	-	kV	
	Human Body Model	25	-	± 15	-	kV	
All Other Pins	Human Body Model	25	-	± 2.5	-	kV	

Notes:

8. These inputs use a positive feedback resistor. The input current is negligible when the input is at either supply rail.
9. An "edge" is defined as a transition through the transmitter or receiver input thresholds.

3. Typical Performance Curves

$V_{CC} = 3.3V$, $T_A = 25^\circ C$

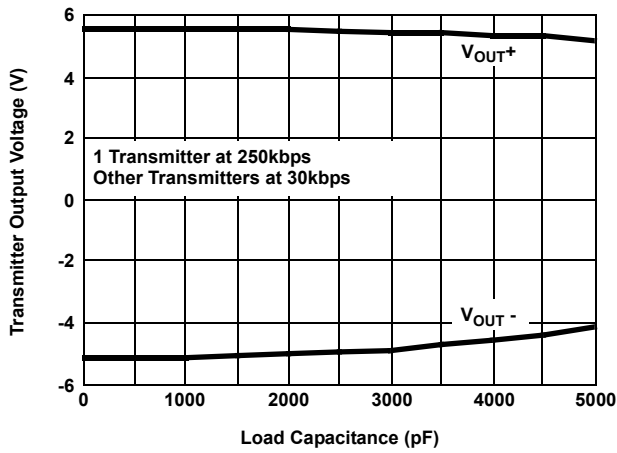

Figure 1. Transmitter Output Voltage vs Load Capacitance

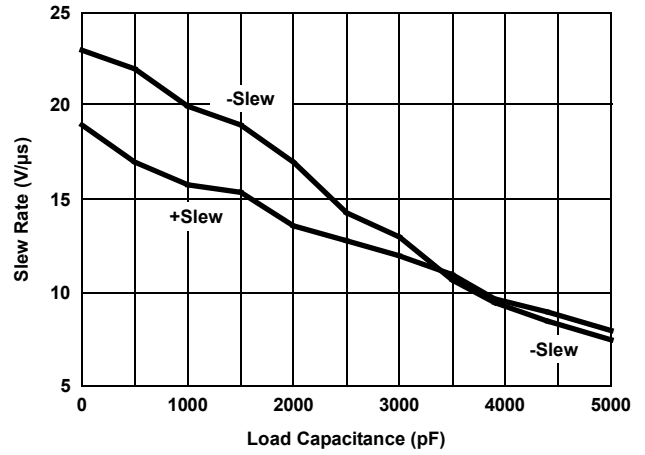

Figure 2. Slew Rate vs Load Capacitance

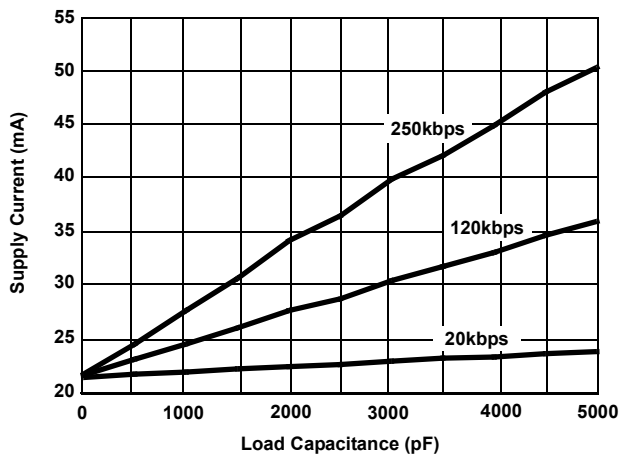

Figure 3. Supply Current vs Load Capacitance When Transmitting Data

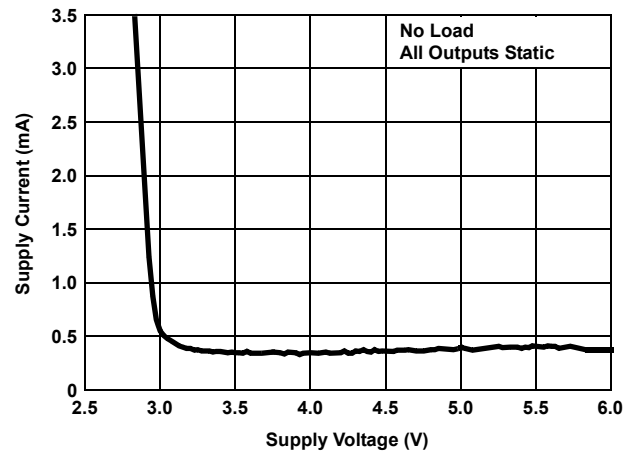

Figure 4. Supply Current vs Supply Voltage

4. Application Information

The ICL3238E operates from a single +3V to +5.5V supply, ensures a 250kbps minimum data rate, requires only four small external 0.1 μ F (0.22 μ F for $V_{CC} = 3.0V$) capacitors, features low power consumption, and meets all EIA/TIA-232 and V.28 specifications.

4.1 Charge Pump

The ICL32xxE family uses regulated on-chip dual charge pumps as voltage doublers, and voltage inverters to generate $\pm 5.5V$ transmitter supplies from a V_{CC} supply as low as 3.0V. The charge pumps allow these devices to maintain RS-232 compliant output levels over the $\pm 10\%$ tolerance range of 3.3V powered systems. The efficient on-chip power supplies require only four small external 0.1 μ F capacitors for the voltage doubler and inverter functions at $V_{CC} = 3.3V$. See [“Enhanced Automatic Powerdown” on page 15](#) and [Table 6](#) for capacitor recommendations for other operating conditions. The charge pumps operate discontinuously (turning off as soon as the V+ and V- supplies are pumped up to the nominal values) and provide significant power savings.

4.1.1 Charge Pump Abs Max Ratings

The ICL3238E is fully characterized for 3.0V to 3.6V operation, and at critical points for 4.5V to 5.5V operation. Furthermore, load conditions were favorable using static logic states only.

The specified maximum values for V+ and V- are +7V and -7V, respectively. These limits apply for V_{CC} values set to 3.0V and 3.6V (see [Table 2](#)). For V_{CC} values set to 4.5V and 5.5V, the maximum values for V+ and V- can approach +9V and -7V, respectively ([Table 3 on page 11](#)). The breakdown characteristics for V+ and V- were measured with $\pm 13V$.

Table 2. V+ and V- Values for $V_{CC} = 3.0V$ to 3.6V

C ₁ (μ F)	C ₂ , C ₃ , C ₄ (μ F)	Load	T1IN (Logic State)	V+ (V)		V- (V)	
				V _{CC} = 3.0V	V _{CC} = 3.6V	V _{CC} = 3.0V	V _{CC} = 3.6V
0.1	0.1	Open	H	5.80	6.56	-5.60	-5.88
			L	5.80	6.56	-5.60	-5.88
			2.4kbps	5.80	6.56	-5.60	-5.88
		3k Ω // 1000pF	H	5.88	6.60	-5.56	-5.92
			L	5.76	6.36	-5.56	-5.76
			2.4kbps	6.00	6.64	-5.64	-5.96
0.047	0.33	Open	H	5.68	6.00	-5.60	-5.60
			L	5.68	6.00	-5.60	-5.60
			2.4kbps	5.68	6.00	-5.60	-5.60
		3k Ω // 1000pF	H	5.76	6.08	-5.64	-5.64
			L	5.68	6.04	-5.60	-5.60
			2.4kbps	5.84	6.16	-5.64	-5.72
1	1	Open	H	5.88	6.24	-5.60	-5.60
			L	5.88	6.28	-5.60	-5.64
			2.4kbps	5.80	6.20	-5.60	-5.60
		3k Ω // 1000pF	H	5.88	6.44	-5.64	-5.72
			L	5.88	6.04	-5.64	-5.64
			2.4kbps	5.92	6.40	-5.64	-5.64

Table 3. V+ and V- Values for $V_{CC} = 4.5V$ to $5.5V$

C_1 (μF)	C_2, C_3, C_4 (μF)	Load	T1IN (Logic State)	V+ (V)		V- (V)	
				$V_{CC} = 4.5V$	$V_{CC} = 5.5V$	$V_{CC} = 4.5V$	$V_{CC} = 5.5V$
0.1	0.1	Open	H	7.44	8.48	-6.16	-6.40
			L	7.44	8.48	-6.16	-6.44
			2.4kbps	7.44	8.48	-6.17	-6.44
		3k Ω // 1000pF	H	7.76	8.88	-6.36	-6.72
			L	7.08	8.00	-5.76	-5.76
			2.4kbps	7.76	8.84	-6.40	-6.64
0.047	0.33	Open	H	6.44	6.88	-5.80	-5.88
			L	6.48	6.88	-5.84	-5.88
			2.4kbps	6.44	6.88	-5.80	-5.88
		3k Ω // 1000pF	H	6.64	7.28	-5.92	-6.04
			L	6.24	6.60	-5.52	-5.52
			2.4kbps	6.72	7.16	-5.92	-5.96
1	1	Open	H	6.84	7.60	-5.76	-5.76
			L	6.88	7.60	-5.76	-5.76
			2.4kbps	6.92	7.56	-5.72	-5.76
		3k Ω // 1000pF	H	7.28	8.16	-5.80	-5.92
			L	6.44	6.84	-5.64	-6.84
			2.4kbps	7.08	7.76	-5.80	-5.80

The resulting new maximum voltages at V+ and V- are listed in [Table 4](#).

Table 4. New Measured Withstanding Voltages

V+, V- to Ground	$\pm 13V$
V+ to V-	20V

4.2 Transmitters

The transmitters are proprietary, low dropout, inverting drivers that translate TTL/CMOS inputs to EIA/TIA-232 output levels. The transmitters are coupled with the on-chip $\pm 5.5V$ supplies to deliver true RS-232 levels across a wide range of single supply system voltages.

The transmitter outputs disable and assume a high impedance state when the device enters the powerdown mode (see [Table 5 on page 12](#)). The outputs can be driven to $\pm 12V$ when disabled.

All devices ensure a 250kbps data rate for full load conditions (3k Ω and 1000pF), $V_{CC} \geq 3.0V$, with one transmitter operating at full speed. Under more typical conditions of $V_{CC} \geq 3.3V$, $R_L = 3k\Omega$, and $C_L = 250pF$, one transmitter easily operates at 1Mbps.

The transmitter inputs incorporate an active positive feedback resistor that maintains the last driven input state in the absence of a forcing signal. Unused transmitter inputs can remain unconnected.

4.3 Receivers

The ICL3238E contains both standard inverting, three-state receivers and a single noninverting (monitor) receiver (denoted by the R_{OUTB} label) that is always active, regardless of the state of any control lines. Both receiver types convert RS-232 signals to CMOS output levels and accept inputs up to $\pm 25V$ while presenting the required 3k Ω to 7k Ω input impedance (see [Figure 5 on page 12](#)) even if the power is off ($V_{CC} = 0V$). The receivers' Schmitt trigger input stage uses hysteresis to increase noise immunity and decrease errors due to slow input signal transitions. The inverting receivers disable during forced (manual) powerdown, but not during automatic powerdown (see [Table 5](#)).

Table 5. Powerdown Logic Truth Table

Rcvr Or Xmtr Edge Within 30 Sec?	$\overline{\text{FORCEOFF}}$ Input	FORCEON Input	Transmitter Outputs	Receiver Outputs	ROUTB Output	RS-232 Level Present at Receiver Input?	$\overline{\text{INVALID}}$ Output	Mode of Operation
No	H	H	Active	Active	Active	No	L	Normal Operation (Enhanced Auto Powerdown Disabled)
No	H	H	Active	Active	Active	Yes	H	
Yes	H	L	Active	Active	Active	No	L	Normal Operation (Enhanced Auto Powerdown Enabled)
Yes	H	L	Active	Active	Active	Yes	H	
No	H	L	High-Z	Active	Active	No	L	Powerdown Due to Enhanced Auto Powerdown Logic
No	H	L	High-Z	Active	Active	Yes	H	
X	L	X	High-Z	High-Z	Active	No	L	Manual Powerdown
X	L	X	High-Z	High-Z	Active	Yes	H	
INVALID Driving FORCEON and FORCEOFF (Emulates Automatic Powerdown)								
X	Note 10	Note 10	Active	Active	Active	Yes	H	Normal Operation
X	Note 10	Note 10	High-Z	High-Z	Active	No	L	Forced Auto Powerdown

Note:
10. Input is connected to $\overline{\text{INVALID}}$ Output.

Conversely, the monitor receiver remains active even during manual powerdown, so it is extremely useful for RING INDICATOR monitoring. Standard receivers driving powered down peripherals must be disabled to prevent current flow through the peripheral's protection diodes (see [Figures 6](#) and [7](#)). Disabling the receivers prevents them from being used for wake up functions, but the corresponding monitor receiver can be dedicated to this task as shown in [Figure 7](#).

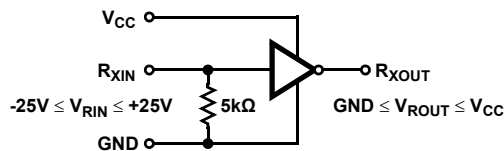

Figure 5. Inverting Receiver Connections

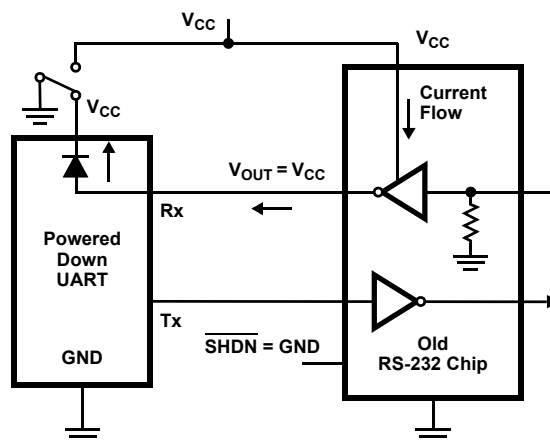

Figure 6. Power Drain Through Powered Down Peripheral

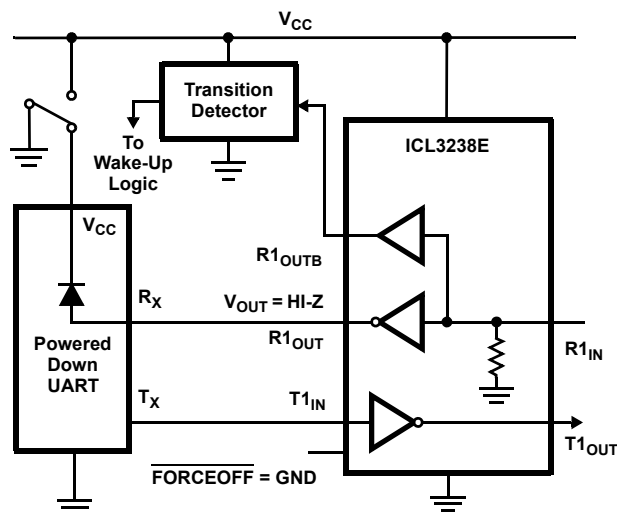

Figure 7. Disabled Receivers Prevent Power Drain

4.4 Operation Down to 2.7V

The ICL3238E transmitter outputs meet RS-562 levels ($\pm 3.7V$), at full data rate with V_{CC} as low as 2.7V. RS-562 levels typically ensure interoperability with RS-232 devices.

4.5 Powerdown Functionality

The ICL3238E requires a nominal supply current of 0.3mA during normal operation (not in powerdown mode). This supply current is considerably less than the 5mA to 11mA current required by 5V RS-232 devices. The already low current requirement drops significantly when the device enters powerdown. In powerdown, supply current drops to 10nA because the on-chip charge pump turns off ($V+$ collapses to V_{CC} , $V-$ collapses to GND), and the transmitter outputs tri-state. This micro-power mode makes the ICL3238E ideal for battery powered and portable applications.

4.5.1 Software Controlled (Manual) Powerdown

The ICL3238E allows you to force the IC into the low power standby state, and uses a two pin approach where the $\overline{FORCEON}$ and $\overline{FORCEOFF}$ inputs determine the IC's mode. For always enabled operation, $\overline{FORCEON}$ and $\overline{FORCEOFF}$ are both strapped high. Under logic or software control, only the $\overline{FORCEOFF}$ input needs to be driven to switch between active and powerdown modes. The $\overline{FORCEON}$ state is not critical because $\overline{FORCEOFF}$ overrides $\overline{FORCEON}$. However, if strictly manual control over powerdown is needed, you must strap $\overline{FORCEON}$ high to disable the enhanced automatic powerdown circuitry. The ICL3238E inverting (standard) receiver outputs also disable when the ICL3238E is in manual powerdown. The disabled receiver outputs eliminate the possible current path through a shutdown peripheral's input protection diode (see [Figures 6 and 7](#)).

Connecting $\overline{FORCEOFF}$ and $\overline{FORCEON}$ together disables the enhanced automatic powerdown feature and enables them to function as a manual $\overline{SHUTDOWN}$ input (see [Figure 9 on page 14](#)).

4.5.2 INVALID Output

Table 5 shows that the $\overline{INVALID}$ output always indicates whether 30 μ s have elapsed with invalid RS-232 signals persisting on all of the receiver inputs (see [Figures 8 and 12](#)). The indicator provides an easy way to determine when the interface block should power down. Invalid receiver levels occur whenever the driving peripheral's outputs are shut off (powered down) or when the RS-232 interface cable is disconnected. If an interface cable is disconnected and all the receiver inputs are floating (but pulled to GND by the internal receiver pull down resistors), the $\overline{INVALID}$ logic detects the invalid levels and drives the output low. The power management logic then uses this indicator to power down the interface block. Reconnecting the cable restores valid levels at the receiver inputs, $\overline{INVALID}$ switches high, and the power management logic wakes up the interface block. $\overline{INVALID}$ can also be used to indicate the DTR or RING INDICATOR signal as long as the other receiver inputs are floating, or driven to GND (as in the case of a powered down driver).

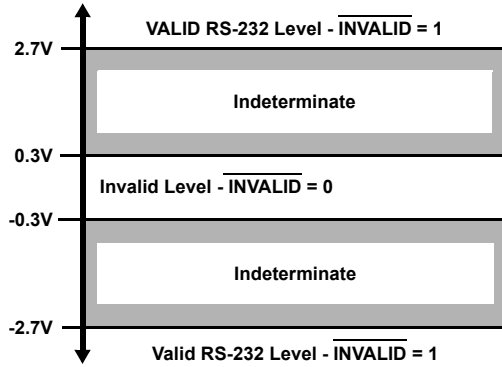

Figure 8. Definition of Valid RS-232 Receiver Levels

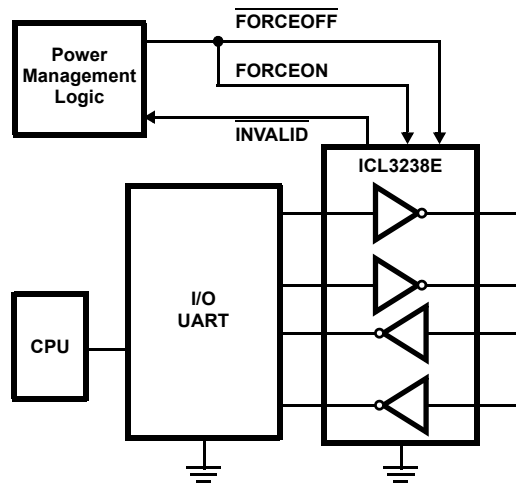

Figure 9. Connections for Manual Powerdown When No Valid Receiver Signals are Present

With any of the above control schemes, the time required to exit powerdown and resume transmission is only 25µs.

When using both manual and enhanced automatic powerdown (FORCEON = 0), the ICL3238E does not power up from manual powerdown until both FORCEOFF and FORCEON are driven high or until a transition occurs on a receiver or transmitter input. Figure 10 shows a circuit for ensuring that the ICL3238E powers up as soon as FORCEOFF switches high. The rising edge of the Master Powerdown signal forces the device to power up and the ICL3238E returns to enhanced automatic powerdown mode an RC time constant after this rising edge. The time constant is not critical because the ICL3238E remains powered up for 30 seconds after the FORCEON falling edge, even if there are no signal transitions. This gives slow-to-wake systems (for example, a mouse) plenty of time to start transmitting, and as long as it starts transmitting within 30 seconds both systems remain enabled.

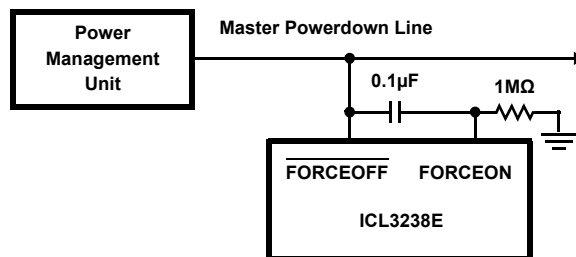

Figure 10. Circuit to Ensure Immediate Power Up When Exiting Forced Powerdown

4.5.3 Enhanced Automatic Powerdown

Even greater power savings are available by using the enhanced automatic powerdown function. When the enhanced powerdown logic determines that no transitions have occurred on any of the transmitter or receiver inputs for 30 seconds, the charge pump and transmitters power down and reduce the supply current to 10nA. The ICL3238E automatically powers back up whenever it detects a transition on one of these inputs. The automatic powerdown feature provides additional system power savings without changes to the existing operating system.

Enhanced automatic powerdown operates when the FORCEON input is low and the $\overline{\text{FORCEOFF}}$ input is high. Tying FORCEON high disables automatic powerdown, but manual powerdown is always available from the overriding $\overline{\text{FORCEOFF}}$ input. [Table 5 on page 12](#) summarizes the enhanced automatic powerdown functionality. [Figure 11](#) shows the enhanced powerdown control logic.

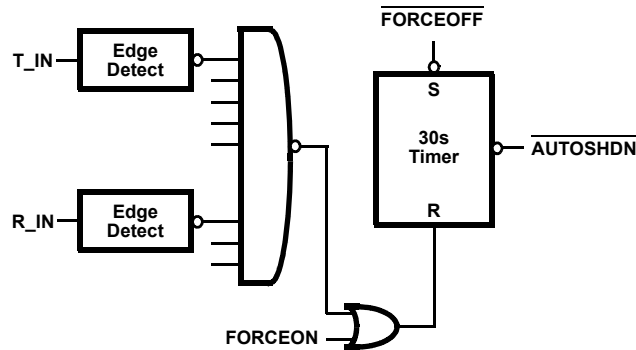

Figure 11. Enhanced Automatic Powerdown Logic

Note: When the ICL3238E enters powerdown (manually or automatically), the 30 second timer remains timed out (set) and keeps the ICL3238E powered down until FORCEON transitions high, or until a transition occurs on a receiver or transmitter input.

The $\overline{\text{INVALID}}$ output signal switches low to indicate that invalid levels have persisted on all of the receiver inputs for more than 60 μs (see [Figure 12](#)), but this has no direct effect on the state of the ICL3238E (see [“Emulating Standard Automatic Powerdown” on page 16](#) and [“Enhanced Automatic Powerdown” on page 15](#) for methods of using $\overline{\text{INVALID}}$ to power down the device). $\overline{\text{INVALID}}$ switches high 1 μs after detecting a valid RS-232 level on a receiver input. $\overline{\text{INVALID}}$ operates in all modes (forced or automatic powerdown, or forced on), so it is also useful for systems employing manual powerdown circuitry. The time to recover from automatic powerdown mode is typically 25 μs .

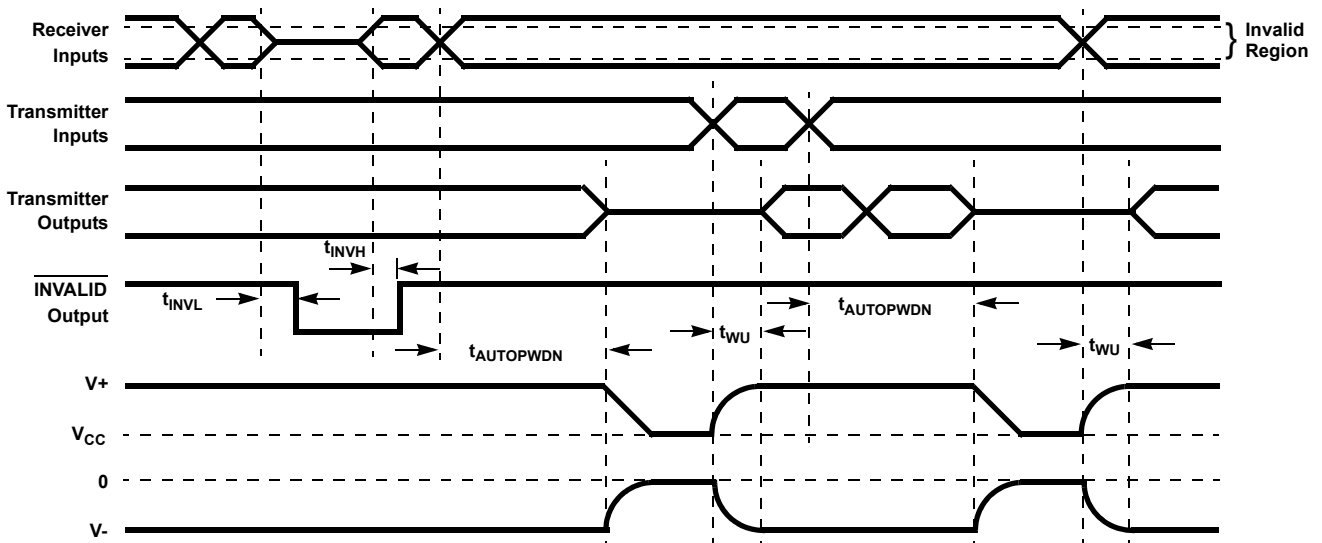

Figure 12. Enhanced Automatic Powerdown and $\overline{\text{INVALID}}$ Timing Diagrams

4.5.4 Emulating Standard Automatic Powerdown

If enhanced automatic powerdown is not required, you can implement the standard automatic powerdown feature (mimics the function on the ICL3221, ICL3223, and ICL3243E) by connecting the $\overline{\text{INVALID}}$ output to the $\overline{\text{FORCEON}}$ and $\overline{\text{FORCEOFF}}$ inputs, as shown in Figure 13. After 60 μs of invalid receiver levels, $\overline{\text{INVALID}}$ switches low and drives the ICL3238E into a forced powerdown condition. $\overline{\text{INVALID}}$ switches high as soon as a receiver input senses a valid RS-232 level and forces the ICL3238E to power on. See the “ $\overline{\text{INVALID}}$ DRIVING $\overline{\text{FORCEON}}$ AND $\overline{\text{FORCEOFF}}$ ” section of Table 5 for an operational summary. This operational mode is perfect for handheld devices that communicate with another computer through a detachable cable. Detaching the cable allows the internal receiver pull-down resistors to pull the inputs to GND (an invalid RS-232 level) and causes the 60 μs timer to time out and drive the IC into powerdown. Reconnecting the cable restores valid levels and causes the IC to power back up.

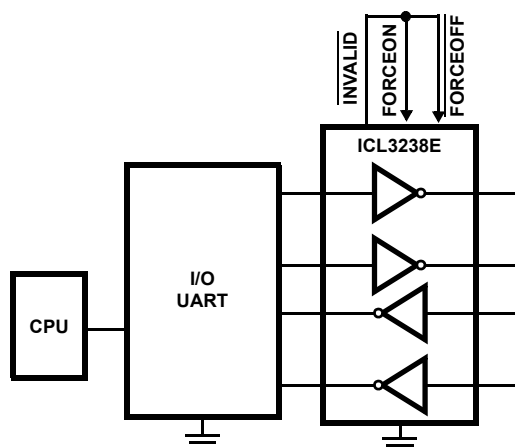

Figure 13. Connections for Automatic Powerdown When No Valid Receiver Signals are Present

4.5.5 Hybrid Automatic Powerdown Options

For devices that communicate only through a detachable cable, you can connect $\overline{\text{INVALID}}$ to $\overline{\text{FORCEOFF}}$ (with $\overline{\text{FORCEON}} = 0$). While the cable is attached, $\overline{\text{INVALID}}$ and $\overline{\text{FORCEOFF}}$ remain high, so the enhanced automatic powerdown logic powers down the RS-232 device whenever there is 30 seconds of inactivity on the receiver and transmitter inputs. Detaching the cable allows the receiver inputs to drop to an invalid level (GND), so $\overline{\text{INVALID}}$ switches low and forces the RS-232 device to power down. The ICL3238E remains powered down until the cable is reconnected ($\overline{\text{INVALID}} = \overline{\text{FORCEOFF}} = 1$) and a transition occurs on a receiver or transmitter input (see Figure 11). For immediate power up when the cable is reattached, connect $\overline{\text{FORCEON}}$ to $\overline{\text{FORCEOFF}}$ through a network similar to that shown in Figure 10.

4.6 Capacitor Selection

The charge pumps require 0.1 μF or greater capacitors for 3.3V (5% tolerance) operation. For other supply voltages, see Table 6 for capacitor values. Do not use values smaller than those listed in Table 6. Increasing the capacitor values (by a factor of 2) reduces ripple on the transmitter outputs and slightly reduces power consumption. C_2 , C_3 , and C_4 can be increased without increasing C_1 's value; however, do not increase C_1 without also increasing C_2 , C_3 , and C_4 to maintain the proper ratios (C_1 to the other capacitors).

Table 6. Required Capacitor Values

V_{CC} (V)	C_1 (μF)	C_2, C_3, C_4 (μF)
3.0 to 3.6 (3.3V $\pm 10\%$)	0.22	0.22
3.15 to 3.6 (3.3V $\pm 5\%$)	0.1	0.1
4.5 to 5.5	0.047	0.33
3.0 to 5.5	0.22	1

When using minimum required capacitor values, make sure that capacitor values do not degrade excessively with temperature. If in doubt, use capacitors with a larger nominal value. The capacitor's equivalent series resistance (ESR) usually rises at low temperatures and influences the amount of ripple on V+ and V-.

4.7 Power Supply Decoupling

In most circumstances a 0.1µF bypass capacitor is adequate. In applications that are particularly sensitive to power supply noise, decouple V_{CC} to ground with a capacitor of the same value as the charge pump capacitor C₁. Connect the bypass capacitor as close as possible to the IC.

4.8 Transmitter Outputs when Exiting Powerdown

Figure 14 shows the response of two transmitter outputs when exiting powerdown mode. As the two transmitter outputs activate, they properly go to opposite RS-232 levels with no glitching, ringing, or undesirable transients. Each transmitter is loaded with 3kΩ in parallel with 2500pF. **Note:** The transmitters enable only when the magnitude of the supplies exceeds approximately 3V.

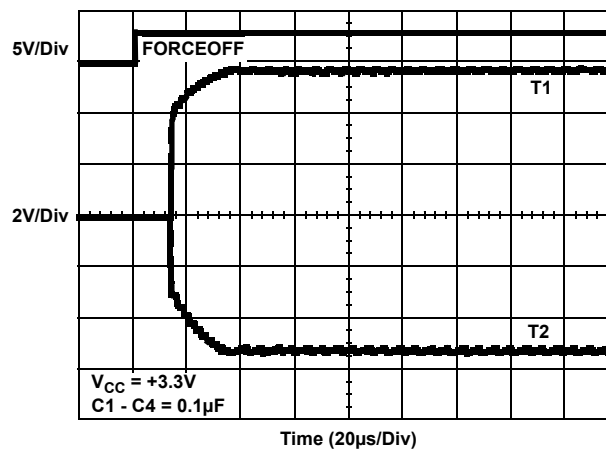

Figure 14. Transmitter Outputs When Exiting Powerdown

4.9 High Data Rates

The ICL3238E maintains the RS-232 $\pm 5V$ minimum transmitter output voltages even at high data rates. [Figure 15](#) shows a transmitter loopback test circuit and [Figure 16](#) shows the loopback test result at 120kbps. For this test, all transmitters were simultaneously driving RS-232 loads in parallel with 1000pF at 120kbps. [Figure 17](#) shows the loopback results for a single transmitter driving 1000pF and an RS-232 load at 250kbps. The static transmitters were also loaded with an RS-232 receiver.

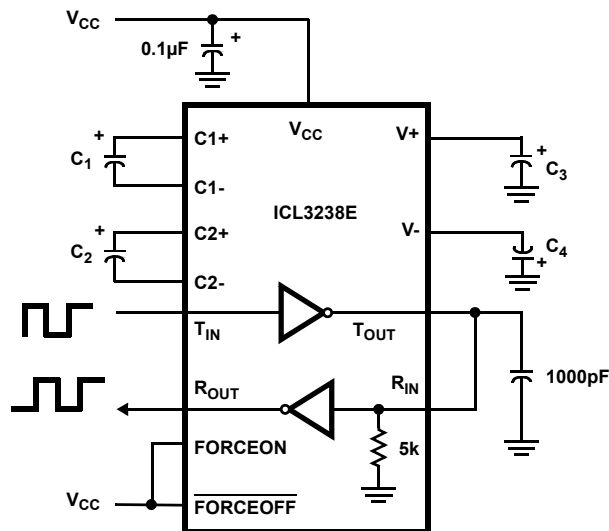

Figure 15. Transmitter Loopback Test Circuit

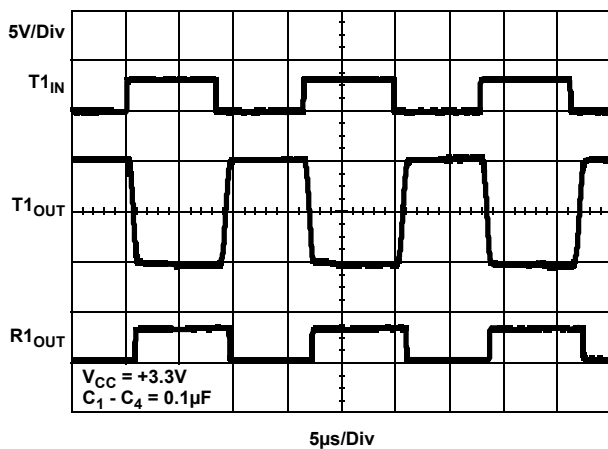

Figure 16. Loopback Test at 120kbps

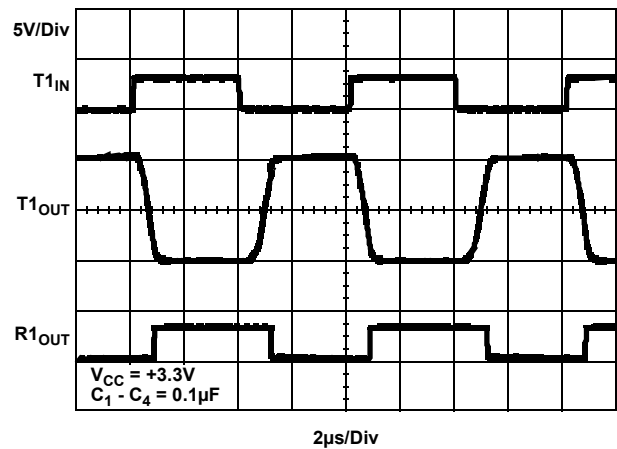

Figure 17. Loopback Test at 250kbps

4.10 Interconnection with 3V and 5V Logic

The ICL3238E directly interfaces with 5V CMOS and TTL logic families. AC, HC, and CD4000 outputs can drive the ICL32xx inputs with the ICL32xx at 3.3V and the logic supply at 5V, but the ICL32xx outputs do not reach the minimum V_{IH} for these logic families. See [Table 7](#) for more information.

Table 7. Logic Family Compatibility with Various Supply Voltages

System Power-Supply Voltage (V)	V _{CC} Supply Voltage (V)	Compatibility
3.3	3.3	Compatible with all CMOS families.
5	5	Compatible with all TTL and CMOS logic families.
5	3.3	Compatible with ACT and HCT CMOS, and with TTL. ICL32xx outputs are incompatible with AC, HC, and CD4000 CMOS inputs.

5. ±15kV ESD Protection

All pins on the ICL32xx devices include ESD protection structures, but the ICL32xxE family incorporates advanced structures that allow the RS-232 pins (transmitter outputs and receiver inputs) to survive ESD events up to ±15kV. The RS-232 pins are particularly vulnerable to ESD damage because they typically connect to an exposed port on the exterior of the finished product. Touching the port pins or connecting a cable can cause an ESD event that might destroy unprotected ICs. The ESD structures protect the device whether or not it is powered up, protect without allowing any latchup mechanism to activate, and do not interfere with RS-232 signals as large as ±25V.

5.1 Human Body Model (HBM) Testing

The Human Body Model (HBM) test method emulates the ESD event delivered to an IC during human handling. The tester delivers the charge through a 1.5kΩ current limiting resistor, so the test is less severe than the IEC61000 test, which uses a 330Ω limiting resistor. The HBM method determines an IC's ability to withstand the ESD transients typically present during handling and manufacturing. Due to the random nature of these events, each pin is tested with respect to all other pins. The RS-232 pins on "E" family devices can withstand HBM ESD events to ±15kV.

5.2 IEC61000-4-2 Testing

The IEC61000 test method applies to finished equipment, rather than to an individual IC. Therefore, the pins most likely to suffer an ESD event are those that are exposed to the outside world (the RS-232 pins in this case), and the IC is tested in its typical application configuration (power applied) rather than testing each pin-to-pin combination. The lower current limiting resistor coupled with the larger charge storage capacitor yields a test that is much more severe than the HBM test. The extra ESD protection built into this device's RS-232 pins allows the design of equipment meeting level 4 criteria without the need for additional board level protection on the RS-232 port.

5.3 Air-Gap Discharge Test Method

For the air-gap discharge test method, a charged probe tip moves toward the IC pin until the voltage arcs to it. The current waveform delivered to the IC pin depends on factors such as approach speed, humidity, and temperature, so it is difficult to obtain repeatable results. The "E" device RS-232 pins withstand ±15kV air-gap discharges.

5.4 Contact Discharge Test Method

During the contact discharge test, the probe contacts the tested pin before the probe tip is energized and eliminates the variables associated with the air-gap discharge. The result is a more repeatable and predictable test, but equipment limits prevent testing devices at voltages higher than ±8kV. All "E" family devices survive ±8kV contact discharges on the RS-232 pins.

6. Die Characteristics

Substrate Potential (Powered Up)	GND
Transistor Count	1235
Process	Si Gate CMOS

7. Revision History

Rev.	Date	Description
6.00	Apr.26.19	Added Related Literature section on page 1. Updated ordering information table: -Removed ICL3238ECA, ICL3238ECA-T ICL3238EIA, ICL3238EIA-T, and ICL3238EIV-T -Added ICL3238EIVZ -Added information about replacement parts for the end of life ICL3238ECAZ and ICL3238ECAZ-T -Added tape and reel column and Notes 1, 2, and 3 Added Charge Pump Abs Max Ratings section starting on page 10. Updated package outline drawing M28.209 from revision 1 to revision 2. Remove "u" symbol from drawing (overlaps the "a" on Side View). Updated package outline drawing M28.173 from revision 0 to revision 1. Convert to new POD format by moving dimensions from table onto drawing and adding land pattern. No dimension changes. Applied new template. Updated disclaimer.

8. Package Outline Drawings

For the most recent package outline drawing, see [M28.209](#).

M28.209 (JEDEC MO-150-AH ISSUE B)
28 Lead Shrink Small Outline Plastic Package (SSOP)

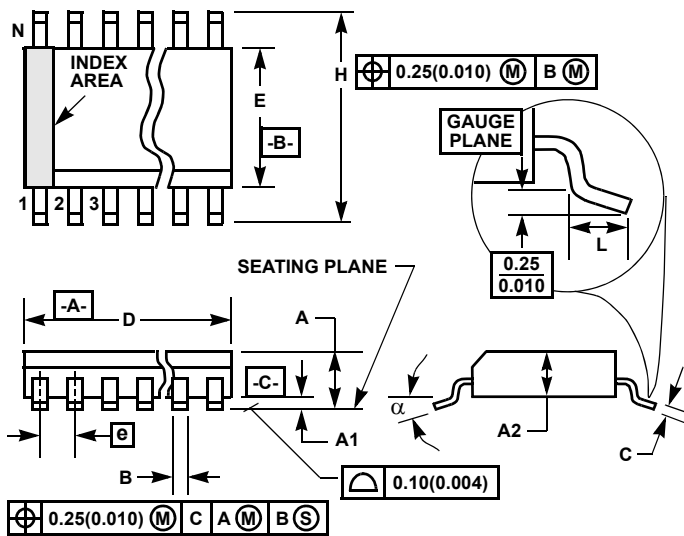

SYMBOL	INCHES		MILLIMETERS		NOTES
	MIN	MAX	MIN	MAX	
A	-	0.078	-	2.00	-
A1	0.002	-	0.05	-	-
A2	0.065	0.072	1.65	1.85	-
B	0.009	0.014	0.22	0.38	9
C	0.004	0.009	0.09	0.25	-
D	0.390	0.413	9.90	10.50	3
E	0.197	0.220	5.00	5.60	4
e	0.026 BSC		0.65 BSC		-
H	0.292	0.322	7.40	8.20	-
L	0.022	0.037	0.55	0.95	6
N	28		28		7
α	0°	8°	0°	8°	-

Rev. 2 6/05

Notes:

1. Symbols are defined in the "MO Series Symbol List" in Section 2.2 of Publication Number 95.
2. Dimensioning and tolerancing per ANSI Y14.5M-1982.
3. Dimension "D" does not include mold flash, protrusions or gate burrs. Mold flash, protrusion and gate burrs shall not exceed 0.20mm (0.0078 inch) per side.
4. Dimension "E" does not include interlead flash or protrusions. Interlead flash and protrusions shall not exceed 0.20mm (0.0078 inch) per side.
5. The chamfer on the body is optional. If it is not present, a visual index feature must be located within the crosshatched area.
6. "L" is the length of terminal for soldering to a substrate.
7. "N" is the number of terminal positions.
8. Terminal numbers are shown for reference only.
9. Dimension "B" does not include dambar protrusion. Allowable dambar protrusion shall be 0.13mm (0.005 inch) total in excess of "B" dimension at maximum material condition.
10. Controlling dimension: MILLIMETER. Converted inch dimensions are not necessarily exact.

M28.173
 28 Lead Thin Shrink Small Outline Package (TSSOP)
 Rev 1, 5/10

For the most recent package outline drawing, see [M28.173](#).

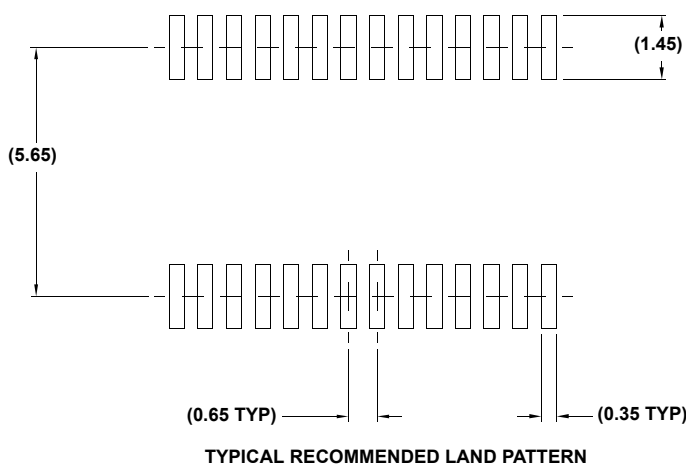
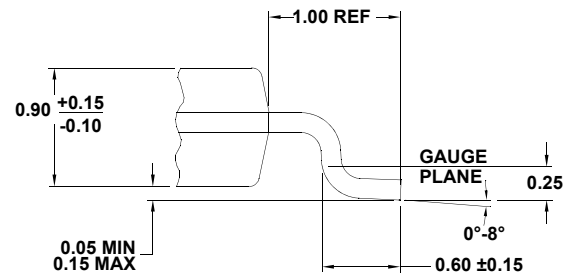
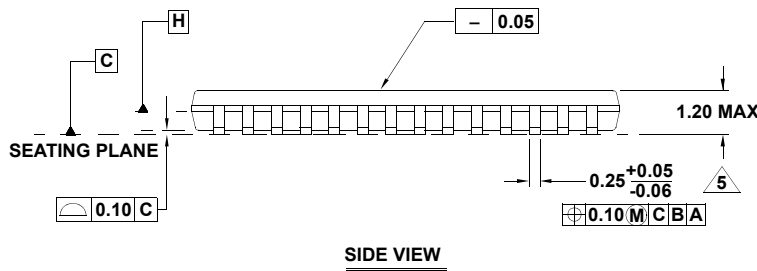
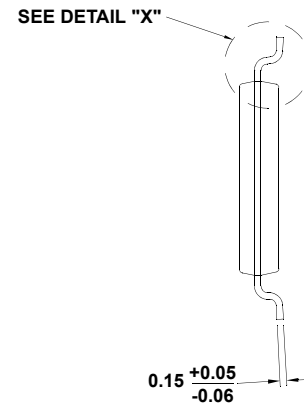
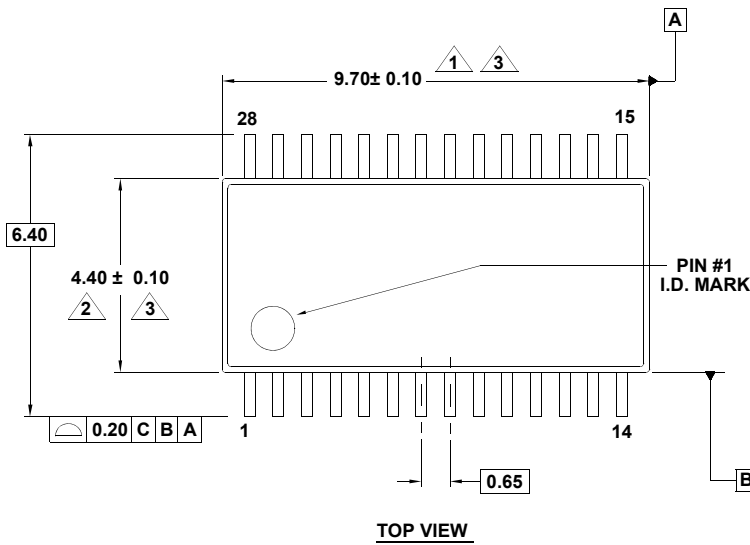

NOTES:

1. Dimension does not include mold flash, protrusions or gate burrs. Mold flash, protrusions or gate burrs shall not exceed 0.15 per side.
2. Dimension does not include interlead flash or protrusion. Interlead flash or protrusion shall not exceed 0.25 per side.
3. Dimensions are measured at datum plane H.
4. Dimensioning and tolerancing per ASME Y14.5M-1994.
5. Dimension does not include dambar protrusion. Allowable protrusion shall be 0.08mm total in excess of dimension at maximum material condition. Minimum space between protrusion and adjacent lead is 0.07mm.
6. Dimension in () are for reference only.
7. Conforms to JEDEC MO-153.

Notice

1. Descriptions of circuits, software and other related information in this document are provided only to illustrate the operation of semiconductor products and application examples. You are fully responsible for the incorporation or any other use of the circuits, software, and information in the design of your product or system. Renesas Electronics disclaims any and all liability for any losses and damages incurred by you or third parties arising from the use of these circuits, software, or information.
2. Renesas Electronics hereby expressly disclaims any warranties against and liability for infringement or any other claims involving patents, copyrights, or other intellectual property rights of third parties, by or arising from the use of Renesas Electronics products or technical information described in this document, including but not limited to, the product data, drawings, charts, programs, algorithms, and application examples.
3. No license, express, implied or otherwise, is granted hereby under any patents, copyrights or other intellectual property rights of Renesas Electronics or others.
4. You shall not alter, modify, copy, or reverse engineer any Renesas Electronics product, whether in whole or in part. Renesas Electronics disclaims any and all liability for any losses or damages incurred by you or third parties arising from such alteration, modification, copying or reverse engineering.
5. Renesas Electronics products are classified according to the following two quality grades: "Standard" and "High Quality". The intended applications for each Renesas Electronics product depends on the product's quality grade, as indicated below.
 - "Standard": Computers; office equipment; communications equipment; test and measurement equipment; audio and visual equipment; home electronic appliances; machine tools; personal electronic equipment; industrial robots; etc.
 - "High Quality": Transportation equipment (automobiles, trains, ships, etc.); traffic control (traffic lights); large-scale communication equipment; key financial terminal systems; safety control equipment; etc.Unless expressly designated as a high reliability product or a product for harsh environments in a Renesas Electronics data sheet or other Renesas Electronics document, Renesas Electronics products are not intended or authorized for use in products or systems that may pose a direct threat to human life or bodily injury (artificial life support devices or systems; surgical implantations; etc.), or may cause serious property damage (space system; undersea repeaters; nuclear power control systems; aircraft control systems; key plant systems; military equipment; etc.). Renesas Electronics disclaims any and all liability for any damages or losses incurred by you or any third parties arising from the use of any Renesas Electronics product that is inconsistent with any Renesas Electronics data sheet, user's manual or other Renesas Electronics document.
6. When using Renesas Electronics products, refer to the latest product information (data sheets, user's manuals, application notes, "General Notes for Handling and Using Semiconductor Devices" in the reliability handbook, etc.), and ensure that usage conditions are within the ranges specified by Renesas Electronics with respect to maximum ratings, operating power supply voltage range, heat dissipation characteristics, installation, etc. Renesas Electronics disclaims any and all liability for any malfunctions, failure or accident arising out of the use of Renesas Electronics products outside of such specified ranges.
7. Although Renesas Electronics endeavors to improve the quality and reliability of Renesas Electronics products, semiconductor products have specific characteristics, such as the occurrence of failure at a certain rate and malfunctions under certain use conditions. Unless designated as a high reliability product or a product for harsh environments in a Renesas Electronics data sheet or other Renesas Electronics document, Renesas Electronics products are not subject to radiation resistance design. You are responsible for implementing safety measures to guard against the possibility of bodily injury, injury or damage caused by fire, and/or danger to the public in the event of a failure or malfunction of Renesas Electronics products, such as safety design for hardware and software, including but not limited to redundancy, fire control and malfunction prevention, appropriate treatment for aging degradation or any other appropriate measures. Because the evaluation of microcomputer software alone is very difficult and impractical, you are responsible for evaluating the safety of the final products or systems manufactured by you.
8. Please contact a Renesas Electronics sales office for details as to environmental matters such as the environmental compatibility of each Renesas Electronics product. You are responsible for carefully and sufficiently investigating applicable laws and regulations that regulate the inclusion or use of controlled substances, including without limitation, the EU RoHS Directive, and using Renesas Electronics products in compliance with all these applicable laws and regulations. Renesas Electronics disclaims any and all liability for damages or losses occurring as a result of your noncompliance with applicable laws and regulations.
9. Renesas Electronics products and technologies shall not be used for or incorporated into any products or systems whose manufacture, use, or sale is prohibited under any applicable domestic or foreign laws or regulations. You shall comply with any applicable export control laws and regulations promulgated and administered by the governments of any countries asserting jurisdiction over the parties or transactions.
10. It is the responsibility of the buyer or distributor of Renesas Electronics products, or any other party who distributes, disposes of, or otherwise sells or transfers the product to a third party, to notify such third party in advance of the contents and conditions set forth in this document.
11. This document shall not be reprinted, reproduced or duplicated in any form, in whole or in part, without prior written consent of Renesas Electronics.
12. Please contact a Renesas Electronics sales office if you have any questions regarding the information contained in this document or Renesas Electronics products.

(Note1) "Renesas Electronics" as used in this document means Renesas Electronics Corporation and also includes its directly or indirectly controlled subsidiaries.

(Note2) "Renesas Electronics product(s)" means any product developed or manufactured by or for Renesas Electronics.

(Rev.4.0-1 November 2017)

Corporate Headquarters

TOYOSU FORESIA, 3-2-24 Toyosu,
Koto-ku, Tokyo 135-0061, Japan
www.renesas.com

Trademarks

Renesas and the Renesas logo are trademarks of Renesas Electronics Corporation. All trademarks and registered trademarks are the property of their respective owners.

Contact Information

For further information on a product, technology, the most up-to-date version of a document, or your nearest sales office, please visit:
www.renesas.com/contact/

X-ON Electronics

Largest Supplier of Electrical and Electronic Components

Click to view similar products for [RS-232 Interface IC category](#):

Click to view products by [Renesas manufacturer](#):

Other Similar products are found below :

[062191EB](#) [CH438L](#) [LT1039CN](#) [LTC1327CNW](#) [LTC1327CSW](#) [MAX3386ECPWR](#) [TRS222IDWR](#) [MAX232INE4](#) [MAX3232CPW](#)
[MAX204CWE+](#) [TRS3243EIDWR](#) [TRS3232EIDWR](#) [TRS3222ECPWR](#) [SN65C3232EDWR](#) [ADM208ARZ-REEL](#) [LT1780CSW#PBF](#)
[LT1237CSW#PBF](#) [LT1281AISW#PBF](#) [LTC1337CSW#PBF](#) [LT1180ACN#PBF](#) [LT1237CNW#PBF](#) [LT1039CN#PBF](#) [LT1032CSW#PBF](#)
[LT1130ACSW#PBF](#) [LT1032ISW#PBF](#) [LTM2882IY-3#PBF](#) [LT1140ACN#PBF](#) [LTC1384IG#PBF](#) [ADM211EARUZ-REEL7](#)
[LTC1383CS#PBF](#) [LT1280AIN#PBF](#) [LT1080ISW#PBF](#) [LTC2845IG#PBF](#) [LTC1383CN#PBF](#) [LTC2845CG#PBF](#) [LTC2846CG#PBF](#)
[LTC1384CG#PBF](#) [LT1781IS#PBF](#) [LT1081IN#PBF](#) [LT1131ACNW](#) [LT1131ACSW](#) [SN75188DE4](#) [LTC1350CNW](#) [MAX3209EEUU+T](#)
[AD7306AR](#) [AD7306ARZ](#) [AD7306JNZ](#) [AD7306JRZ](#) [ADM3311EARSZ-REEL](#) [ADM3310EACPZ-REEL7](#)