

ISL28325, ISL28345

40V Low Power Dual and Quad Operational Amplifier

FN7854

Rev 0.00

September 27, 2011

The ISL28325 and ISL28345 are dual and quad general purpose amplifiers featuring low noise vs power consumption. The combination of low noise and small footprint provides the user with outstanding value and flexibility relative to similar competitive parts.

Applications for this amplifier include active filters, medical and analytical instrumentation, power supply controls, and industrial controls.

The ISL28325 is offered in 8 Ld SOIC and MSOP packages and the ISL28345 is offered in the 14 Ld SOIC package and operates over the -40°C to +125°C temperature range.

Features

- Input Offset Voltage.....1mV, Max.
- Input Bias Current±5nA, Max.
- Low Current Consumption500µA
- Voltage Noise9nV/Hz
- Wide Supply Range4.5V to 40V
- Operating Temperature Range.....-40°C to +125°C
- Pb-Free (RoHS Compliant)

Applications

- Analytical Instrumentation
- Medical Instrumentation
- Spectral Analysis Equipment
- Active Filter Blocks
- Thermocouples and RTD Reference Buffers
- Data Acquisition
- Power Supply Control

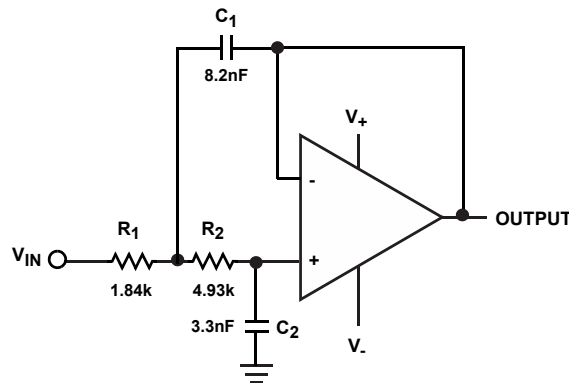

SALLEN-KEY LOW PASS FILTER (10kHz)

FIGURE 1. TYPICAL APPLICATION

Ordering Information

PART NUMBER (Notes 1, 2, 3)	PART MARKING	TEMP RANGE (°C)	PACKAGE (Pb-Free)	PKG. DWG. #
ISL28325FBZ	28325 FBZ	-40 to +125	8 Ld SOIC	M8.15E
ISL28325FUZ	8325Z	-40 to +125	8 Ld MSOP	M8.118B
ISL28345FBZ	28345 FBZ	-40 to +125	14 Ld SOIC	MDP0027

NOTES:

1. Add "-T*" suffix for tape and reel. Please refer to [TB347](#) for details on reel specifications.
2. These Intersil Pb-free plastic packaged products employ special Pb-free material sets, molding compounds/die attach materials, and 100% matte tin plate plus anneal (e3 termination finish, which is RoHS compliant and compatible with both SnPb and Pb-free soldering operations). Intersil Pb-free products are MSL classified at Pb-free peak reflow temperatures that meet or exceed the Pb-free requirements of IPC/JEDEC J STD-020.
3. For Moisture Sensitivity Level (MSL), please see device information page for [ISL28325](#), [ISL28345](#). For more information on MSL please see techbrief [TB363](#).

Pin Configurations

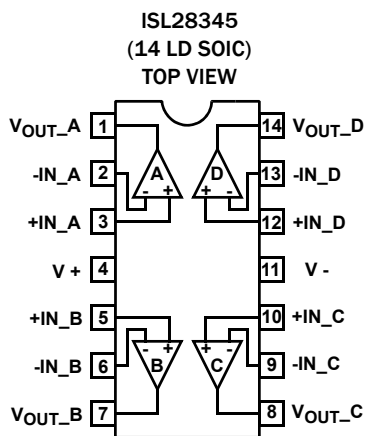
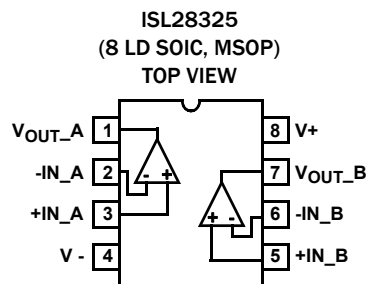

Pin Descriptions

ISL28325 (8 LD SOIC, MSOP)	ISL28345 (14 LD SOIC)	PIN NAME	EQUIVALENT CIRCUIT	DESCRIPTION
3	3	+IN_A	Circuit 1	Amplifier non-inverting input
5	5	+IN_B		
-	10	+IN_C		
-	12	+IN_D		
4	11	V-	Circuit 3	Negative power supply
2	2	-IN_A	Circuit 1	Amplifier inverting input
6	6	-IN_B		
-	9	-IN_C		
-	13	-IN_D		
8	4	V+	Circuit 3	Positive power supply
1	1	V _{OUT_A}	Circuit 2	Amplifier output
7	7	V _{OUT_B}		
-	8	V _{OUT_C}		
-	14	V _{OUT_D}		

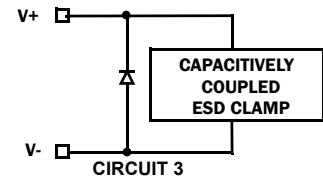
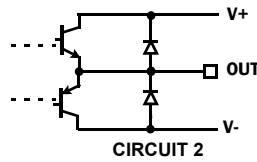

Absolute Maximum Ratings

Maximum Supply Voltage	42V
Maximum Differential Input Current	20mA
Maximum Differential Input Voltage	42V
Min/Max Input Voltage	V- - 0.5V to V+ + 0.5V
Max/Min Input current for Input Voltage >V+ or <V-	±20mA
Output Short-Circuit Duration (1 output at a time)	Indefinite
ESD Rating	
Human Body Model	5kV
Machine Model	300V
Charged Device Model	2kV

Thermal Information

Thermal Resistance (Typical Notes 4, 5)	θ_{JA} (°C/W)	θ_{JC} (°C/W)
8 Ld SOIC	125	65
8 Ld MSOP	160	55
14 Ld SOIC	73	45
Maximum Storage Temperature Range	-65°C to +150°C	
Maximum Junction Temperature (T _{JMAX})	+150°C	
Pb-Free Reflow Profile	see link below	
	http://www.intersil.com/pbfree/Pb-FreeReflow.asp	

Recommended Operating Conditions

Ambient Temperature Range (T_A) -40°C to +125°C

CAUTION: Do not operate at or near the maximum ratings listed for extended periods of time. Exposure to such conditions may adversely impact product reliability and result in failures not covered by warranty.

NOTES:

- θ_{JA} is measured with the component mounted on a high effective thermal conductivity test board in free air. See Tech Brief TB379 for details.
- For θ_{JC} , the "case temp" location is taken at the package top center.

Electrical Specifications V_S ± 5V and V_S ± 15V, V_{CM} = 0, V_O = 0V, T_A = +25°C, unless otherwise noted. **Boldface limits apply over the operating temperature range, -40°C to +125°C.**

PARAMETER	DESCRIPTION	CONDITIONS	MIN (Note 6)	TYP	MAX (Note 6)	UNIT
V _{OS}	Input Offset Voltage		-1	0.1	1	mV
TCV _{OS}	Input V _{OS} Temperature Coefficient			4	15	µV/C
I _B	Input Bias Current		-5	0.2	5	nA
I _{OS}	Input Offset Current		-5	0.2	5	nA
V _{CM}	Input Voltage Range		-13		13	V
CMRR	Common-Mode Rejection Ratio	V _{CM} = -13V to +13V	80	100		dB
PSRR	Power Supply Rejection Ratio	V _S = ±2.25V to ±20V	80	100		dB
A _{VOL}	Open-Loop Gain	V _O = -13V to +13V, R _L = 10kΩ to ground	100	110		dB
V _{OH}	Output Voltage High	R _L = 10kΩ to ground	13.0	13.5		V
V _{OL}	Output Voltage Low	R _L = 10kΩ to ground		-13.7	-13.5	V
I _S	Supply Current/Amplifier			0.5	0.7	mA
					0.9	mA
I _{SC}	Short-Circuit			40		mA
V _{SUPPLY}	Supply Voltage Range		± 2.25		± 20	V
AC SPECIFICATIONS						
GBWP	Gain Bandwidth Product	A _V = 1k, R _L = 2kΩ		1.2		MHz
SR	Slew Rate, V _{OUT} 20% to 80%	A _V = 11, R _L = 2kΩ, V _O = 4V _{P-P}		0.4		V/µs
e _{nVp-p}	Voltage Noise V _{P-P}	0.1Hz to 10Hz		0.4		µV _{P-P}
e _n	Voltage Noise Density	f = 1kHz		9		nV/√Hz
i _n	Current Noise Density	f = 1kHz		0.1		pA/√Hz

NOTE:

- Compliance to datasheet limits is assured by one or more methods: production test, characterization and/or design.

Typical Performance Curves

$V_S = \pm 15V$, $V_{CM} = 0V$, $R_L = \text{Open}$, unless otherwise specified.



FIGURE 2. OPEN-LOOP GAIN, PHASE vs FREQUENCY, $R_L = 10k\Omega$, $C_L = 10pF$

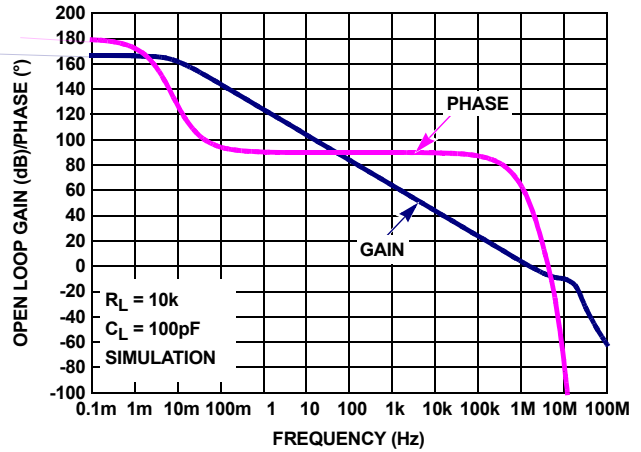

FIGURE 3. OPEN-LOOP GAIN, PHASE vs FREQUENCY, $R_L = 10k\Omega$, $C_L = 100pF$

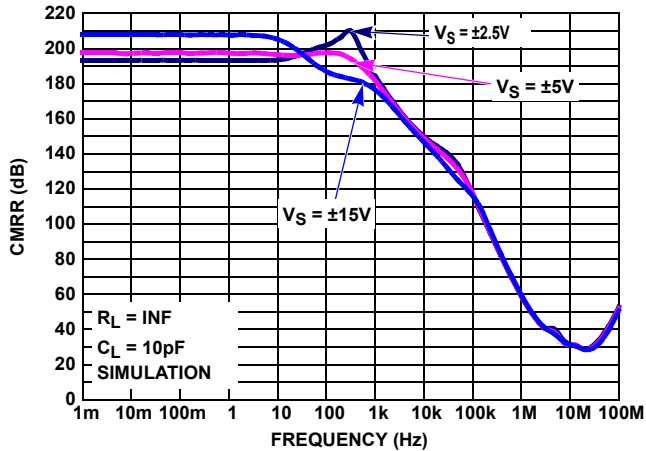

FIGURE 4. CMRR vs FREQUENCY, $V_S = \pm 2.25, \pm 5V, \pm 15V$



FIGURE 5. SMALL SIGNAL TRANSIENT RESPONSE, $V_S = \pm 5V, \pm 15V$



FIGURE 6. LARGE SIGNAL TRANSIENT RESPONSE vs R_L $V_S = \pm 5V, \pm 15V$

Applications Information

Functional Description

The ISL28325 and ISL28345 are dual and quad general purpose amplifiers featuring low noise vs power consumption. They are offered in industry standard pinouts in 8 Ld SOIC, 8 Ld MSOP and 14 Ld SOIC packages. Applications for this amplifier include active filters, medical and analytical instrumentation, power supply controls, and industrial controls..

Operating Voltage Range

The devices are designed to operate over the 4.5V ($\pm 2.25V$) to 40V ($\pm 20V$) range over the $-40^{\circ}C$ to $+125^{\circ}C$ temperature range. For best amplifier performance, decouple the power supply with a $0.01\mu F$ or larger capacitors by placing them close to the supply pins of the amplifier.

Input ESD Diode Protection

The input terminals (IN+ and IN-) have internal ESD protection diodes to the positive and negative supply rails, series connected 500Ω current limiting resistors and an anti-parallel diode pair across the inputs.

The series resistors limit the high feed-through currents that can occur in pulse applications when the input dV/dT exceeds the $0.4V/\mu s$ slew rate of the amplifier. Without the series resistors, the input can forward-bias the anti-parallel diodes causing current to flow to the output resulting in severe distortion and possible diode failure.

In applications where one or both amplifier input terminals are at risk of exposure to high voltages beyond the power supply rails, current limiting resistors may be needed at the input terminal to limit the current through the power supply ESD diodes to 20mA max.

Revision History

The revision history provided is for informational purposes only and is believed to be accurate, but not warranted. Please go to web to make sure you have the latest revision.

DATE	REVISION	CHANGE
09/27/2011	FN7854.0	Initial Release

Products

Intersil Corporation is a leader in the design and manufacture of high-performance analog semiconductors. The Company's products address some of the industry's fastest growing markets, such as, flat panel displays, cell phones, handheld products, and notebooks. Intersil's product families address power management and analog signal processing functions. Go to www.intersil.com/products for a complete list of Intersil product families.

For a complete listing of Applications, Related Documentation and Related Parts, please see the respective device information page on intersil.com: [ISL28325, ISL28345](http://www.intersil.com/products)

To report errors or suggestions for this datasheet, please go to: www.intersil.com/askourstaff

FITs are available from our website at: <http://rel.intersil.com/reports/search.php>

© Copyright Intersil Americas LLC 2011. All Rights Reserved.

All trademarks and registered trademarks are the property of their respective owners.

For additional products, see www.intersil.com/en/products.html

Intersil products are manufactured, assembled and tested utilizing ISO9001 quality systems as noted in the quality certifications found at www.intersil.com/en/support/qualandreliability.html

Intersil products are sold by description only. Intersil may modify the circuit design and/or specifications of products at any time without notice, provided that such modification does not, in Intersil's sole judgment, affect the form, fit or function of the product. Accordingly, the reader is cautioned to verify that datasheets are current before placing orders. Information furnished by Intersil is believed to be accurate and reliable. However, no responsibility is assumed by Intersil or its subsidiaries for its use; nor for any infringements of patents or other rights of third parties which may result from its use. No license is granted by implication or otherwise under any patent or patent rights of Intersil or its subsidiaries.

For information regarding Intersil Corporation and its products, see www.intersil.com

Package Outline Drawing

M8.15E

8 LEAD NARROW BODY SMALL OUTLINE PLASTIC PACKAGE

Rev 0, 08/09



NOTES:

1. Dimensions are in millimeters.
Dimensions in () for Reference Only.
2. Dimensioning and tolerancing conform to AMSE Y14.5m-1994.
3. Unless otherwise specified, tolerance : Decimal ± 0.05
4. Dimension does not include interlead flash or protrusions.
Interlead flash or protrusions shall not exceed 0.25mm per side.
5. The pin #1 identifier may be either a mold or mark feature.
6. Reference to JEDEC MS-012.

Package Outline Drawing

M8.118B

8 LEAD MINI SMALL OUTLINE PLASTIC PACKAGE

Rev 0, 7/11



NOTES:

1. Dimensions are in millimeters.
2. Dimensioning and tolerancing conform to JEDEC MO-187-AA and AMSEY14.5m-1994.
3. Plastic or metal protrusions of 0.15mm max per side are not included.
4. Plastic interlead protrusions of 0.15mm max per side are not included.
5. Dimensions are measured at Datum Plane "H".
6. Dimensions in () are for reference only.

Small Outline Package Family (SO)



MDP0027

SMALL OUTLINE PACKAGE FAMILY (SO)

SYMBOL	INCHES							TOLERANCE	NOTES
	SO-8	SO-14	SO16 (0.150")	SO16 (0.300") (SOL-16)	SO20 (SOL-20)	SO24 (SOL-24)	SO28 (SOL-28)		
A	0.068	0.068	0.068	0.104	0.104	0.104	0.104	MAX	-
A1	0.006	0.006	0.006	0.007	0.007	0.007	0.007	±0.003	-
A2	0.057	0.057	0.057	0.092	0.092	0.092	0.092	±0.002	-
b	0.017	0.017	0.017	0.017	0.017	0.017	0.017	±0.003	-
c	0.009	0.009	0.009	0.011	0.011	0.011	0.011	±0.001	-
D	0.193	0.341	0.390	0.406	0.504	0.606	0.704	±0.004	1, 3
E	0.236	0.236	0.236	0.406	0.406	0.406	0.406	±0.008	-
E1	0.154	0.154	0.154	0.295	0.295	0.295	0.295	±0.004	2, 3
e	0.050	0.050	0.050	0.050	0.050	0.050	0.050	Basic	-
L	0.025	0.025	0.025	0.030	0.030	0.030	0.030	±0.009	-
L1	0.041	0.041	0.041	0.056	0.056	0.056	0.056	Basic	-
h	0.013	0.013	0.013	0.020	0.020	0.020	0.020	Reference	-
N	8	14	16	16	20	24	28	Reference	-

Rev. M 2/07

NOTES:

1. Plastic or metal protrusions of 0.006" maximum per side are not included.
2. Plastic interlead protrusions of 0.010" maximum per side are not included.
3. Dimensions "D" and "E1" are measured at Datum Plane "H".
4. Dimensioning and tolerancing per ASME Y14.5M-1994

X-ON Electronics

Largest Supplier of Electrical and Electronic Components

Click to view similar products for [Operational Amplifiers - Op Amps](#) category:

Click to view products by [Renesas](#) manufacturer:

Other Similar products are found below :

[OPA2991IDSGR](#) [OPA607IDCKT](#) [007614D](#) [633773R](#) [635798C](#) [635801A](#) [702115D](#) [709228FB](#) [741528D](#) [NCV33072ADR2G](#)
[SC2903VDR2G](#) [LM258AYDT](#) [LM358SNG](#) [430227FB](#) [430228DB](#) [460932C](#) [AZV831KTR-G1](#) [409256CB](#) [430232AB](#) [LM2904DR2GH](#)
[LM358YDT](#) [LT1678IS8](#) [042225DB](#) [058184EB](#) [070530X](#) [714228XB](#) [714846BB](#) [873836HB](#) [MIC918YC5-TR](#) [TS912BIYDT](#)
[NCS2004MUTAG](#) [NCV33202DMR2G](#) [M38510/13101BPA](#) [NTE925](#) [SC2904DR2G](#) [SC358DR2G](#) [LM358EDR2G](#) [AP4310AUMTR-AG1](#)
[HA1630D02MMEL-E](#) [NJM358CG-TE2](#) [HA1630S01LPEL-E](#) [LM324AWPT](#) [HA1630Q06TELL-E](#) [NJM4558CG-TE2](#) [AZV358MMTR-G1](#)
[SCY33178DR2G](#) [NCS4325DR2G](#) [LM7301SN1T1G](#) [NJU77806F3-TE1](#) [NCV833DR2G](#)