



+1.8V to +5.5V, 2.5Ω, Single SPDT Analog Switch

ISL54503

The Intersil ISL54503 device is a low ON-resistance, low voltage, bidirectional, single pole/double throw (SPDT) analog switch designed to operate from a single +1.8V to +5.5V supply. Targeted applications include battery powered equipment that benefit from low ON-resistance (2.5Ω) and fast switching speeds ($t_{ON} = 25ns$, $t_{OFF} = 15ns$). The digital logic input is 1.8V CMOS compatible when using a single +3V supply.

Cell phones, for example, often face ASIC functionality limitations. The number of analog input or GPIO pins may be limited and digital geometries are not well suited to analog switch performance. This part may be used to "mux-in" additional functionality while reducing ASIC design risk. The ISL54503 is offered in a 6 Ld 1.2mmx1.0mmx0.4mm pitch μTDFN package and a 6 Ld SOT-23 package, alleviating board space limitations.

The ISL54503 is a committed SPDT that consist of one normally open (NO) and one normally closed (NC) switch. This configuration can also be used as a 2-to-1 multiplexer.

TABLE 1. FEATURES AT A GLANCE

	ISL54503
Number of Switches	1
SW	SPDT or 2-1 MUX
1.8V r_{ON}	6Ω
1.8V t_{ON}/t_{OFF}	65ns/40ns
3V r_{ON}	3Ω
3V t_{ON}/t_{OFF}	30ns/20ns
5V r_{ON}	2.5Ω
5V t_{ON}/t_{OFF}	25ns/15ns
Package	6 Ld μTDFN, 6 Ld SOT-23

Features

- ON-resistance (r_{ON})
 - $V_{CC} = +5.0V$ 2.5Ω
 - $V_{CC} = +3.0V$ 4.0Ω
 - $V_{CC} = +1.8V$ 7.0Ω
- r_{ON} matching between channels 3mΩ
- r_{ON} flatness (+4.5V Supply) 0.6Ω
- Single supply operation +1.8V to +5.5V
- Fast switching action (+4.5V Supply)
 - t_{ON} 25ns
 - t_{OFF} 15ns
- Guaranteed break-before-make
- ESD HBM rating 6kV
- 1.8V CMOS logic compatible (+3V supply)
- Available in 6 Ld μTDFN and 6 Ld SOT-23 packages
- Pb-free available (RoHS compliant)

Applications

- Battery powered, handheld, and portable equipment
 - Cellular/mobile phones
 - Pagers
 - Laptops, notebooks, palmtops
- Portable test and measurement
- Medical equipment
- Audio and video switching

Related Literature

- Technical Brief TB363 "Guidelines for Handling and Processing Moisture Sensitive Surface Mount Devices (SMDs)"

Ordering Information

PART NUMBER (Notes 1, 4)	PART MARKING	TEMP. RANGE (°C)	PACKAGE Tape & Reel (Pb-Free)	PKG. DWG. #
ISL54503IRUZ-T (Note 2)	3	-40 to +85	6 Ld μ TDFN	L6.1.2x1.0A
ISL54503IHZ-T (Note 3)	4503	-40 to +85	6 Ld SOT-23	MDP0038

- Please refer to [IB347](#) for details on reel specifications.
- These Intersil Pb-free plastic packaged products employ special Pb-free material sets; molding compounds/die attach materials and NiPdAu plate - e4 termination finish, which is RoHS compliant and compatible with both SnPb and Pb-free soldering operations. Intersil Pb-free products are MSL classified at Pb-free peak reflow temperatures that meet or exceed the Pb-free requirements of IPC/JEDEC J STD-020.
- These Intersil Pb-free plastic packaged products employ special Pb-free material sets, molding compounds/die attach materials, and 100% matte tin plate plus anneal (e3 termination finish, which is RoHS compliant and compatible with both SnPb and Pb-free soldering operations). Intersil Pb-free products are MSL classified at Pb-free peak reflow temperatures that meet or exceed the Pb-free requirements of IPC/JEDEC J STD-020.
- For Moisture Sensitivity Level (MSL), please see device information page for [ISL54503](#). For more information on MSL please see techbrief [IB363](#).

Pin Configuration (Note 5)

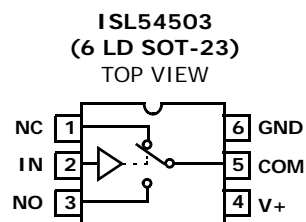
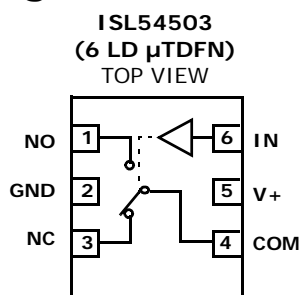

Pin Descriptions

NAME	PIN μ TDFN	PIN SOT-23	FUNCTION
V+	5	4	System Power Supply Input (+1.8V to +5.5V)
GND	2	6	Ground Connection
IN	6	2	Digital Control Input
COM	4	5	Analog Switch Common Pin
NO	1	3	Analog Switch Normally Open Pin
NC	3	1	Analog Switch Normally Closed Pin

NOTE:

- Switches Shown for Logic "0" Input.

Truth Table

LOGIC	PIN NC	PIN NO
0	ON	OFF
1	OFF	ON

NOTE: Logic "0" $\leq 0.5V$. Logic "1" $\geq 1.4V$ with a 3V supply.

Absolute Maximum Ratings

V+ to GND	-0.5 to 6.5V
Input Voltages	
NO, NC, IN (Note 6)	-0.5V to ((V+) + 0.5V)
Output Voltages	
COM (Note 6)	-0.5V to ((V+) + 0.5V)
Continuous Current NO, NC, or COM	±300mA
Peak Current NO, NC, or COM	
(Pulsed 1ms, 10% Duty Cycle, Max)	±500mA
ESD Rating	
Human Body Model	>6kV
Machine Model	>300V
Charged Device Model	>2.2kV

Thermal Information

Thermal Resistance (Typical)	θ_{JA} (°C/W)	θ_{JC} (°C/W)
6 Ld μ TDFN Package (Notes 7, 9)	239.2	111.6
6 Ld SOT-23 Package (Note 8, 9)	260	120
Maximum Junction Temperature (Plastic Package)	+150°C	
Maximum Storage Temperature Range	-65°C to +150°C	
Pb-Free Reflow Profile	see link below	
	http://www.intersil.com/pbfree/Pb-FreeReflow.asp	

Recommended Operating Conditions

V+ (Positive DC Supply Voltage)	1.8V to 5.5V
Analog Signal Range	0V to V+
V _{IN} (Digital Logic Input Voltage (IN))	0V to V+
Temperature Range	-40°C to +85°C

CAUTION: Do not operate at or near the maximum ratings listed for extended periods of time. Exposure to such conditions may adversely impact product reliability and result in failures not covered by warranty.

NOTES:

- Signals on NC, NO, IN, or COM exceeding V+ or GND are clamped by internal diodes. Limit forward diode current to maximum current ratings.
- θ_{JA} is measured in free air with the component mounted on a high effective thermal conductivity test board with "direct attach" features. See Tech Brief TB379.
- θ_{JA} is measured with the component mounted on a high effective thermal conductivity test board in free air. See Tech Brief TB379 for details.
- For θ_{JC} , the "case temp" location is the center of the exposed metal pad on the package underside.

Electrical Specifications - 5V Supply Test Conditions: V+ = +4.5V to +5.5V, GND = 0V, V_{INH} = 2.0V, V_{INL} = 0.8V (Note 10), Unless Otherwise Specified. **Boldface limits apply over the operating temperature range, -40°C to +85°C.**

PARAMETER	TEST CONDITIONS	TEMP (°C)	MIN (Notes 11, 12)	TYP	MAX (Notes 11, 12)	UNITS
ANALOG SWITCH CHARACTERISTICS						
Analog Signal Range, V _{ANALOG}		Full	0	-	V+	V
ON-Resistance, r _{ON}	V+ = 4.5V, I _{COM} = 100mA, V _{NO} or V _{NC} = 0V to V+, (Note 14, See Figure 5)	25	-	2.2	2.5	Ω
		Full	-	-	3	Ω
r _{ON} Matching Between Channels, Δr_{ON}	V+ = 4.5V, I _{COM} = 100mA, V _{NO} or V _{NC} = 2.5V (Note 14)	25	-	0.003	0.1	Ω
		Full	-	-	0.15	Ω
r _{ON} Flatness, r _{FLAT(ON)}	V+ = 4.5V, I _{COM} = 100mA, V _{NO} or V _{NC} = 0V to V+, (Notes 13, 14)	25	-	0.6	0.65	Ω
		Full	-	-	0.7	Ω
NO or NC OFF Leakage Current, I _{NO(OFF)} or I _{NC(OFF)}	V+ = 5.5V, V _{COM} = 0.3V, 5V, V _{NO} or V _{NC} = 5V, 0.3V	25	-25	1.5	25	nA
		Full	-150	-	150	nA
COM ON Leakage Current, I _{COM(ON)}	V+ = 5.5V, V _{COM} = 0.3V, 5V, or V _{NO} or V _{NC} = 0.3V, 5V, or Floating	25	-30	2.8	30	nA
		Full	-300	-	300	nA
DYNAMIC CHARACTERISTICS						
Turn-ON Time, t _{ON}	V+ = 4.5V, V _{NO} or V _{NC} = 3.0V, R _L = 50 Ω , C _L = 35pF (see Figure 1, Note 14)	25	-	25	-	ns
		Full	-	25	-	ns
Turn-OFF Time, t _{OFF}	V+ = 4.5V, V _{NO} or V _{NC} = 3.0V, R _L = 50 Ω , C _L = 35pF (see Figure 1, Note 14)	25	-	15	-	ns
		Full	-	16	-	ns
Break-Before-Make Time Delay, t _D	V+ = 5.5V, V _{NO} or V _{NC} = 3.0V, R _L = 50 Ω , C _L = 35pF (see Figure 3, Note 14)	Full	-	15	-	ns
Charge Injection, Q	V _G = 0V, R _G = 0 Ω , C _L = 1.0nF (see Figure 2)	25	-	24	-	pC
OFF-Isolation	R _L = 50 Ω , C _L = 5pF, f = 1MHz, V _{COM} = 1V _{p-p} (see Figure 4)	25	-	70	-	dB

ISL54503

Electrical Specifications - 5V Supply Test Conditions: $V_+ = +4.5V$ to $+5.5V$, $GND = 0V$, $V_{INH} = 2.0V$, $V_{INL} = 0.8V$ (Note 10), Unless Otherwise Specified. **Boldface limits apply over the operating temperature range, $-40^\circ C$ to $+85^\circ C$.** (Continued)

PARAMETER	TEST CONDITIONS	TEMP (°C)	MIN (Notes 11, 12)	TYP	MAX (Notes 11, 12)	UNITS
Total Harmonic Distortion	$f = 20Hz$ to $20kHz$, $V_{COM} = 2V_{P-P}$, $R_L = 32\Omega$	25	-	0.15	-	%
Total Harmonic Distortion	$f = 20Hz$ to $20kHz$, $V_{COM} = 2V_{P-P}$, $R_L = 600\Omega$	25	-	0.014	-	%
-3dB Bandwidth	$R_L = 50\Omega$	25	-	250	-	MHz
NO or NC OFF Capacitance, C_{OFF}	$V_+ = 4.5V$, $f = 1MHz$, V_{NO} or $V_{NC} = V_{COM} = 0V$ (see Figure 7)	25	-	7	-	pF
COM ON Capacitance, $C_{COM(ON)}$	$V_+ = 4.5V$, $f = 1MHz$, V_{NO} or $V_{NC} = V_{COM} = 0V$ (see Figure 7)	25	-	18	-	pF
POWER SUPPLY CHARACTERISTICS						
Power Supply Range		Full	1.65	-	5.5	V
Positive Supply Current, I_+	$V_+ = 5.5V$, $V_{IN} = 0V$ or V_+	25	-	0.028	0.1	μA
		Full	-	1.1	2.5	μA
DIGITAL INPUT CHARACTERISTICS						
Input Voltage Low, V_{INL}		Full	-	-	0.8	V
Input Voltage High, V_{INH}		Full	2.4	-	-	V
Input Current, I_{INH} , I_{INL}	$V_+ = 5.5V$, $V_{IN} = 0V$ or V_+	Full	-0.1	0.053	0.1	μA

Electrical Specifications - 3V Supply Test Conditions: $V_+ = +2.7V$ to $+3.6V$, $GND = 0V$, $V_{INH} = 1.4V$, $V_{INL} = 0.5V$ (Note 10), Unless Otherwise Specified. **Boldface limits apply over the operating temperature range, $-40^\circ C$ to $+85^\circ C$.**

PARAMETER	TEST CONDITIONS	TEMP (°C)	MIN (Notes 11, 12)	TYP	MAX (Notes 11, 12)	UNITS
ANALOG SWITCH CHARACTERISTICS						
Analog Signal Range, V_{ANALOG}		Full	0	-	V+	V
ON-Resistance, r_{ON} $\mu TDFN$	$V_+ = 2.7V$, $I_{COM} = 100mA$, V_{NO} or $V_{NC} = 0V$ to V_+ , (Note 14, See Figure 5)	25	-	3.3	3.5	Ω
		Full	-	-	4.5	Ω
ON-Resistance, r_{ON} SOT-23	$V_+ = 2.7V$, $I_{COM} = 100mA$, V_{NO} or $V_{NC} = 0V$ to V_+ , (Note 14, See Figure 5)	25	-	3.3	3.6	Ω
		Full	-	-	4.5	Ω
r_{ON} Matching Between Channels, Δr_{ON}	$V_+ = 2.7V$, $I_{COM} = 100mA$, V_{NO} or $V_{NC} = 1.5V$ (Note 14)	25	-	0.006	0.15	Ω
		Full	-	-	0.2	Ω
r_{ON} Flatness, $r_{FLAT(ON)}$ $\mu TDFN$	$V_+ = 2.7V$, $I_{COM} = 100mA$, V_{NO} or $V_{NC} = 0V$ to V_+ , (Notes 13, 14)	25	-	1	1.1	Ω
		Full	-	-	1.2	Ω
r_{ON} Flatness, $r_{FLAT(ON)}$ SOT-23	$V_+ = 2.7V$, $I_{COM} = 100mA$, V_{NO} or $V_{NC} = 0V$ to V_+ , (Notes 13, 14)	25	-	1	1.2	Ω
		Full	-	-	1.3	Ω
DYNAMIC CHARACTERISTICS						
Turn-ON Time, t_{ON}	$V_+ = 2.7V$, V_{NO} or $V_{NC} = 1.5V$, $R_L = 50\Omega$, $C_L = 35pF$ (see Figure 1, Note 14)	25	-	30	-	ns
		Full	-	30	-	ns
Turn-OFF Time, t_{OFF}	$V_+ = 2.7V$, V_{NO} or $V_{NC} = 1.5V$, $R_L = 50\Omega$, $C_L = 35pF$ (see Figure 1, Note 14)	25	-	20	-	ns
		Full	-	20	-	ns
Break-Before-Make Time Delay, t_D	$V_+ = 3.0V$, V_{NO} or $V_{NC} = 1.5V$, $R_L = 50\Omega$, $C_L = 35pF$ (see Figure 3, Note 14)	Full	-	18	-	ns
Charge Injection, Q	$V_G = 0V$, $R_G = 0\Omega$, $C_L = 1.0nF$ (see Figure 2)	25	-	16	-	pC
OFF-Isolation	$R_L = 50\Omega$, $C_L = 5pF$, $f = 1MHz$, $V_{COM} = 1V_{P-P}$ (see Figure 4)	25	-	70	-	dB
Total Harmonic Distortion	$f = 20Hz$ to $20kHz$, $V_{COM} = 2V_{P-P}$, $R_L = 32\Omega$	25	-	0.36	-	%

ISL54503

Electrical Specifications - 3V Supply Test Conditions: $V_+ = +2.7V$ to $+3.6V$, $GND = 0V$, $V_{INH} = 1.4V$, $V_{INL} = 0.5V$ (Note 10), Unless Otherwise Specified. **Boldface limits apply over the operating temperature range, $-40^\circ C$ to $+85^\circ C$.** (Continued)

PARAMETER	TEST CONDITIONS	TEMP (°C)	MIN (Notes 11, 12)	TYP	MAX (Notes 11, 12)	UNITS
Total Harmonic Distortion	$f = 20Hz$ to $20kHz$, $V_{COM} = 2V_{p-p}$, $R_L = 600\Omega$	25	-	0.03	-	%
-3dB Bandwidth	Signal = $0dBm$, $R_L = 50\Omega$	25	-	250	-	MHz
NO or NC OFF Capacitance, C_{OFF}	$f = 1MHz$, V_{NO} or $V_{NC} = V_{COM} = 0V$ (see Figure 7)	25	-	6	-	pF
COM ON Capacitance, $C_{COM(ON)}$	$f = 1MHz$, V_{NO} or $V_{NC} = V_{COM} = 0V$ (see Figure 7)	25	-	18	-	pF
POWER SUPPLY CHARACTERISTICS						
Positive Supply Current, I_+	$V_+ = 3.6V$, $V_{IN} = 0V$ or V_+	25	-	0.013	-	μA
		Full	-	0.7	-	μA
DIGITAL INPUT CHARACTERISTICS						
Input Voltage Low, V_{INL}		Full	-	-	0.5	V
Input Voltage High, V_{INH}		Full	1.4	-	-	V
Input Current, I_{INH} , I_{INL}	$V_+ = 3.6V$, $V_{IN} = 0V$ or V_+	Full	-0.1	0.058	0.1	μA

Electrical Specifications - 1.8V Supply Test Conditions: $V_+ = +1.8V$, $GND = 0V$, $V_{INH} = 1V$, $V_{INL} = 0.4V$ (Note 10), Unless Otherwise Specified. **Boldface limits apply over the operating temperature range, $-40^\circ C$ to $+85^\circ C$.**

PARAMETER	TEST CONDITIONS	TEMP (°C)	MIN (Notes 11, 12)	TYP	MAX (Notes 11, 12)	UNITS
ANALOG SWITCH CHARACTERISTICS						
Analog Signal Range, V_{ANALOG}		Full	0	-	V_+	V
ON-Resistance, r_{ON}	$V_+ = 1.8V$, $I_{COM} = 10mA$, V_{NO} or $V_{NC} = 0V$ to V_+ , (Note 14, See Figure 5)	25	-	6	6.5	Ω
		Full	-	-	7	Ω
DYNAMIC CHARACTERISTICS						
Turn-ON Time, t_{ON}	$V_+ = 1.8V$, V_{NO} or $V_{NC} = 1.5V$, $R_L = 50\Omega$, $C_L = 35pF$ (see Figure 1, Note 14)	25	-	65	-	ns
		Full	-	95	-	ns
Turn-OFF Time, t_{OFF}	$V_+ = 1.8V$, V_{NO} or $V_{NC} = 1.5V$, $R_L = 50\Omega$, $C_L = 35pF$ (see Figure 1, Note 14)	25	-	40	-	ns
		Full	-	65	-	ns
Break-Before-Make Time Delay, t_D	$V_+ = 1.8V$, V_{NO} or $V_{NC} = 1.5V$, $R_L = 50\Omega$, $C_L = 35pF$ (see Figure 3, Note 14)	Full	-	44	-	ns
Charge Injection, Q	$V_G = 0$, $R_G = 0\Omega$, $C_L = 1.0nF$ (see Figure 2)	25	-	8.2	-	pC
DIGITAL INPUT CHARACTERISTICS						
Input Voltage Low, V_{INL}		Full	-	-	0.4	V
Input Voltage High, V_{INH}		Full	1	-	-	V

NOTES:

- V_{IN} = input voltage to perform proper function.
- The algebraic convention, whereby the most negative value is a minimum and the most positive a maximum, is used in this data sheet.
- Parameters with MIN and/or MAX limits are 100% tested at $+25^\circ C$, unless otherwise specified. Temperature limits established by characterization and are not production tested.
- Flatness is defined as the difference between maximum and minimum value of on-resistance over the specified analog signal range.
- Limits established by characterization and are not production tested.

Test Circuits and Waveforms

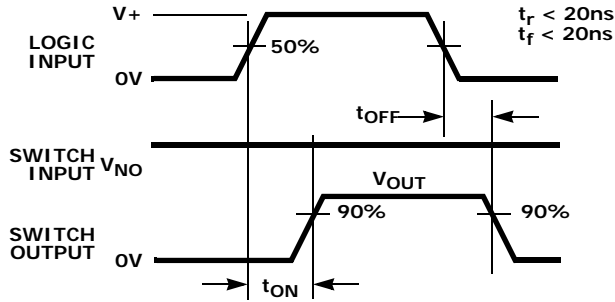

Logic input waveform is inverted for switches that have the opposite logic sense.

FIGURE 1A. MEASUREMENT POINTS

FIGURE 1. SWITCHING TIMES

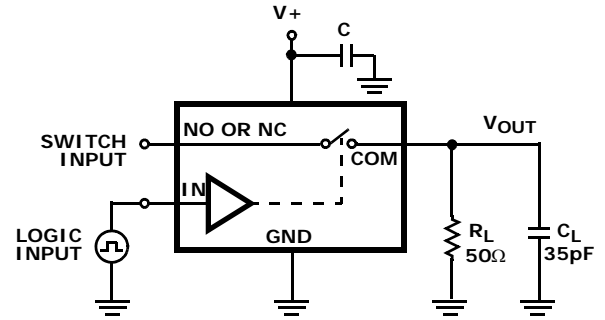

Repeat test for all switches. C_L includes fixture and stray capacitance.

$$V_{OUT} = V_{(NO \text{ OR } NC)} \frac{R_L}{R_L + r_{ON}}$$

FIGURE 1B. TEST CIRCUIT

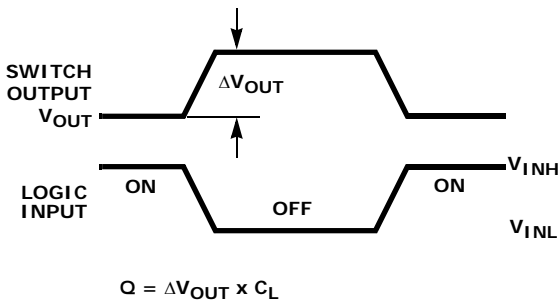

FIGURE 2A. MEASUREMENT POINTS

FIGURE 2. CHARGE INJECTION

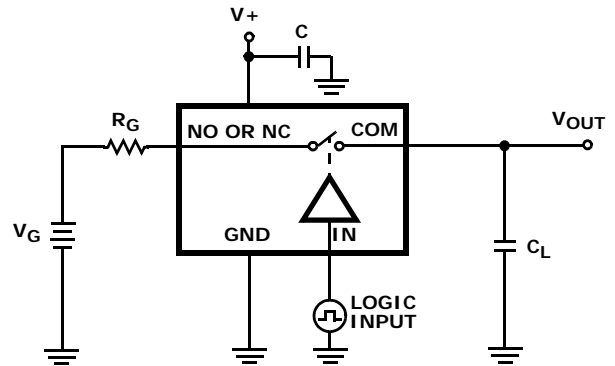

FIGURE 2B. TEST CIRCUIT

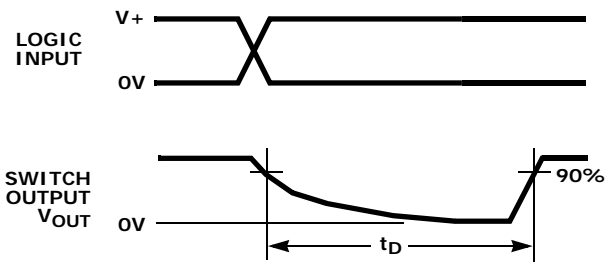
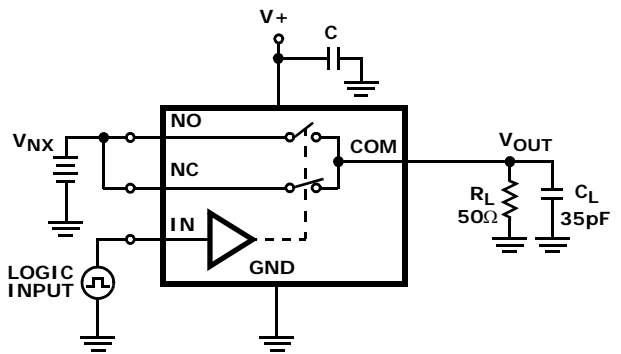

FIGURE 3A. MEASUREMENT POINTS

FIGURE 3. BREAK-BEFORE-MAKE TIME



C_L includes fixture and stray capacitance.

FIGURE 3B. TEST CIRCUIT

Test Circuits and Waveforms (Continued)

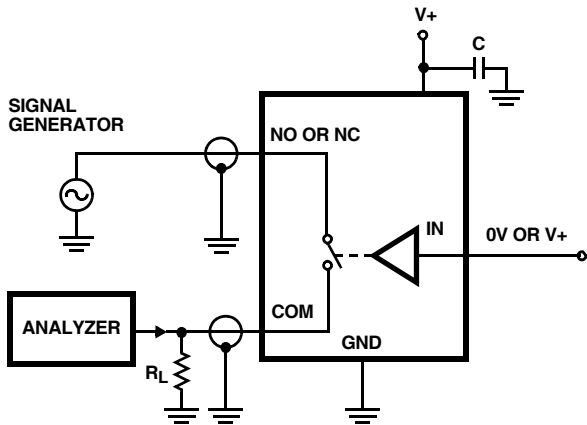

FIGURE 4. OFF-ISOLATION TEST CIRCUIT

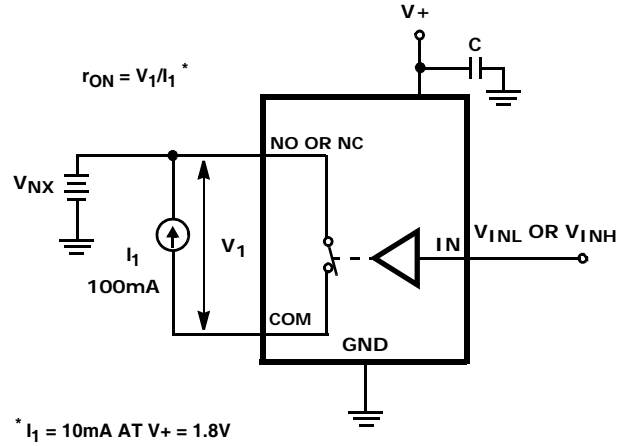

FIGURE 5. r_{ON} TEST CIRCUIT

* $I_1 = 10\text{mA}$ AT $V_+ = 1.8\text{V}$

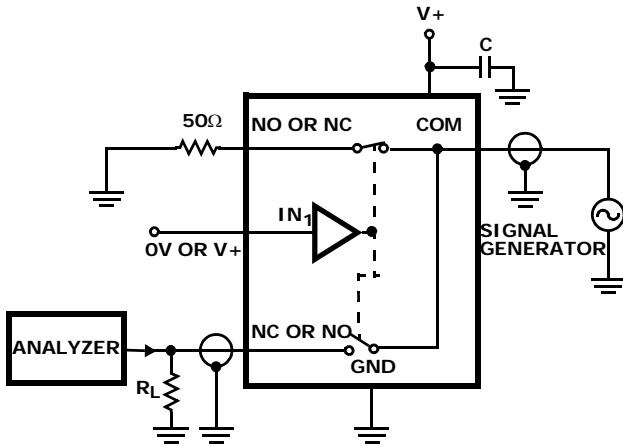

FIGURE 6. CROSSTALK TEST CIRCUIT

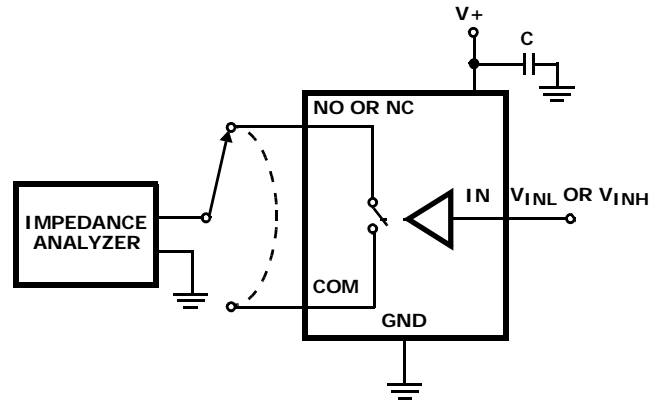

FIGURE 7. CAPACITANCE TEST CIRCUIT

Detailed Description

The ISL54503 is a bi-directional, single pole/double throw (SPDT) analog switch that offers precise switching capability from a single 1.8V to 5.5V supply with low ON-resistance (2.5Ω) and high speed operation ($t_{ON} = 25\text{ns}$, $t_{OFF} = 15\text{ns}$). The device is especially well suited for portable battery powered equipment due to its low operating supply voltage (1.8V), low power consumption ($0.15\mu\text{W}$), low leakage currents (300nA max), and the small μTDFN and SOT-23 packages. The low ON-resistance and r_{ON} flatness provide very low insertion loss and distortion to application that require signal reproduction.

External V+ Series Resistor

For improved ESD and latch-up immunity Intersil recommends adding a 100Ω resistor in series with the V+ power supply pin of the ISL54050 IC (see Figure 8).

During an overvoltage transient event (such as occurs during system level IEC 61000 ESD testing), substrate currents can be generated in the IC that can trigger

parasitic SCR structures to turn ON, creating a low impedance path from the V+ power supply to ground. This will result in a significant amount of current flow in the IC, which can potentially create a latch-up state or permanently damage the IC. The external V+ resistor limits the current during this over-stress situation and has been found to prevent latch-up or destructive damage for many overvoltage transient events.

Under normal operation, the sub-microamp I_{DD} current of the IC produces an insignificant voltage drop across the 100Ω series resistor resulting in no impact to switch operation or performance.

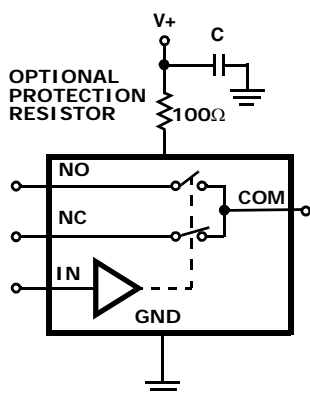

FIGURE 8. V+ SERIES RESISTOR FOR ENHANCED ESD AND LATCH-UP IMMUNITY

Supply Sequencing And Overvoltage Protection

With any CMOS device, proper power supply sequencing is required to protect the device from excessive input currents, which might permanently damage the IC. All I/O pins contain ESD protection diodes from the pin to V+ and to GND (see Figure 9). To prevent forward biasing these diodes, V+ must be applied before any input signals, and the input signal voltages must remain between V+ and GND.

If these conditions cannot be guaranteed then precautions must be implemented to prohibit the current and voltage at the logic pin and signal pins from exceeding the maximum ratings of the switch. The following two methods can be used to provide additional protection to limit the current in the event that the voltage at a signal pin or logic pin goes below ground or above the V+ rail.

Logic inputs can easily be protected by adding a 1kΩ resistor in series with the input (see Figure 9). The resistor limits the input current below the threshold that produces permanent damage, and the sub-microamp input current produces an insignificant voltage drop during normal operation.

This method is not acceptable for the signal path inputs. Adding a series resistor to the switch input defeats the purpose of using a low r_{ON} switch. Connecting Schottky diodes to the signal pins (as shown in Figure 9) will shunt the fault current to the supply or to ground, thereby protecting the switch. These Schottky diodes must be sized to handle the expected fault current.

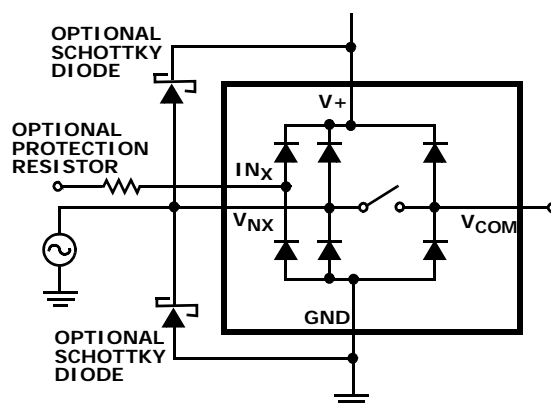

FIGURE 9. OVERVOLTAGE PROTECTION

Power-Supply Considerations

The ISL54503 construction is typical of most single supply CMOS analog switches, in that they have two supply pins: V+ and GND. V+ and GND drive the internal CMOS switches and set their analog voltage limits. Unlike switches with a 4V maximum supply voltage, the ISL54503 5.5V maximum supply voltage provides plenty of room for the 10% tolerance of 3.6V supplies, as well as room for overshoot and noise spikes.

The minimum recommended supply voltage is 1.8V but the part will operate with a supply below 1.8V. It is important to note that the input signal range, switching times, and ON-resistance degrade at lower supply voltages. Refer to the "Electrical Specifications" tables starting on page 3 and the "Typical Performance Curves" starting on page 10 for details.

V+ and GND also power the internal logic and level shifters. The level shifters convert the input logic levels to switched V+ and GND signals to drive the analog switch gate terminals.

This family of switches cannot be operated with bipolar supplies, because the input switching point becomes negative in this configuration.

Logic-Level Thresholds

This switch family is 1.8V CMOS compatible (0.5V and 1.4V) over a supply range of 2V to 3.6V (see Figure 16). At 3.6V the V_{IH} level is about 0.95V. This is still below the 1.8V CMOS guaranteed high output minimum level of 1.4V, but noise margin is reduced.

The digital input stages draw supply current whenever the digital input voltage is not at one of the supply rails. Driving the digital input signals from GND to V+ with a fast transition time minimizes power dissipation.

High-Frequency Performance

In 50Ω systems, the ISL54503 has a -3dB bandwidth of 250MHz (see Figure 17). The frequency response is very consistent over a wide V+ range, and for varying analog signal levels.

An OFF switch behaves like a capacitor and passes higher frequencies with less attenuation, resulting in signal feed-through from a switch's input to output. Off-isolation is the resistance of this signal feed-through. Figure 18 details the high off-isolation provided by the ISL54503. At 1MHz, off-isolation is about 70dB in 50Ω systems, decreasing approximately 20dB per decade as frequency increases. Higher load impedances decrease off-isolation due to the voltage divider action of the switch OFF impedance and the load impedance.

Leakage Considerations

ESD protection diodes are internally connected between each analog-signal pin and both V+ and GND. One of these diodes conducts if any analog signal exceeds V+ or GND.

Virtually all the analog leakage current comes from the ESD diodes to V+ or GND. Although the ESD diodes on a given signal pin are identical and therefore fairly well balanced, they are reverse biased differently. Each is biased by either V+ or GND and the analog signal. This means their leakages will vary as the signal varies. The difference in the two diode leakages to the V+ and GND pins constitutes the analog-signal-path leakage current. All analog leakage current flows between each pin and one of the supply terminals, not to the other switch terminal. This is why both sides of a given switch can show leakage currents of the same or opposite polarity. There is no connection between the analog signal paths and V+ or GND.

Typical Performance Curves $T_A = 25^\circ\text{C}$, Unless Otherwise Specified

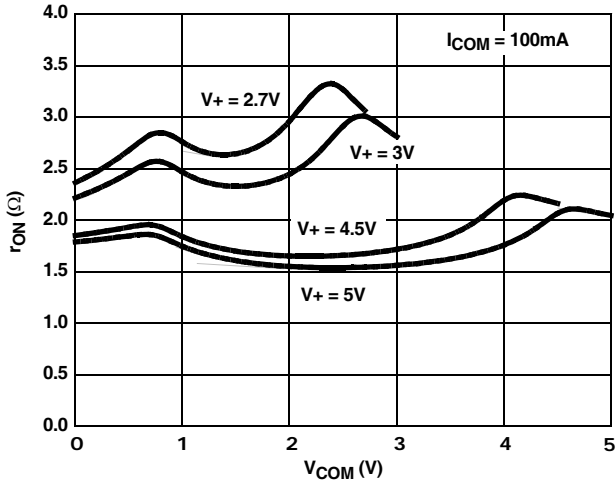

FIGURE 10. ON-RESISTANCE vs SUPPLY VOLTAGE vs SWITCH VOLTAGE

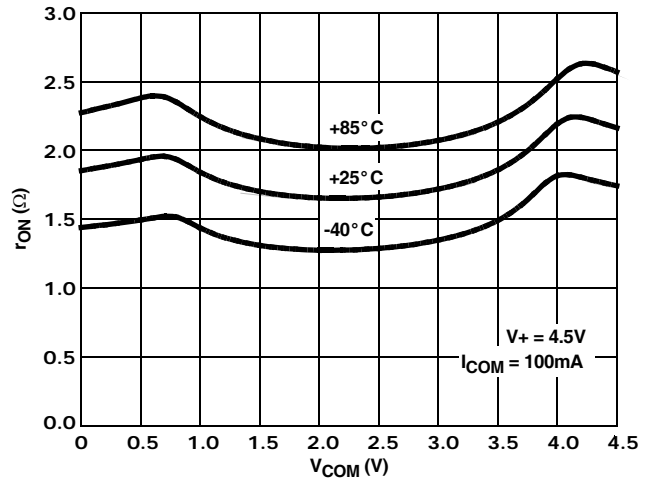

FIGURE 11. ON-RESISTANCE vs SWITCH VOLTAGE

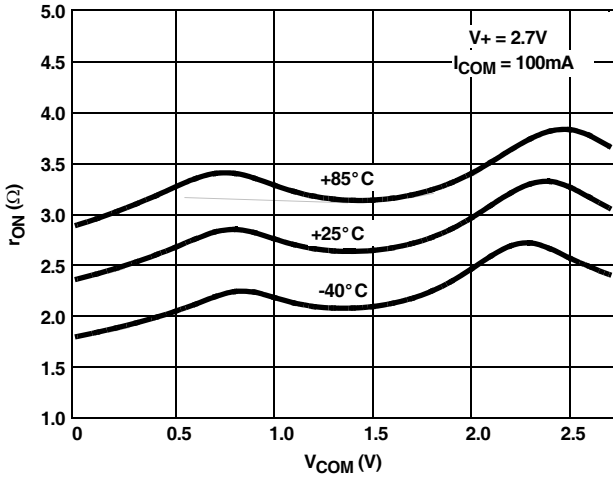

FIGURE 12. ON-RESISTANCE vs SWITCH VOLTAGE

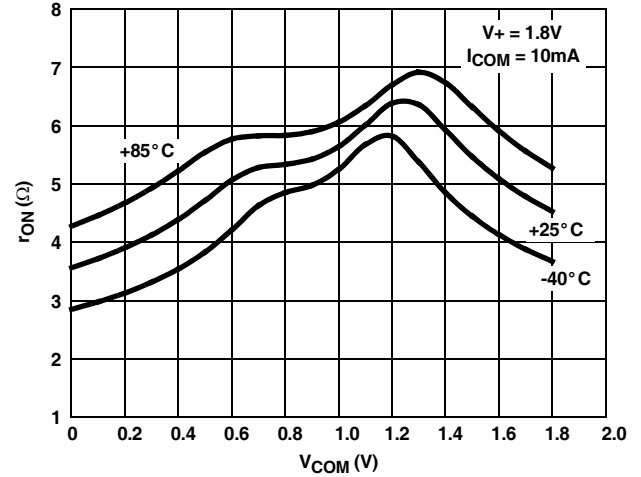

FIGURE 13. ON-RESISTANCE vs SWITCH VOLTAGE

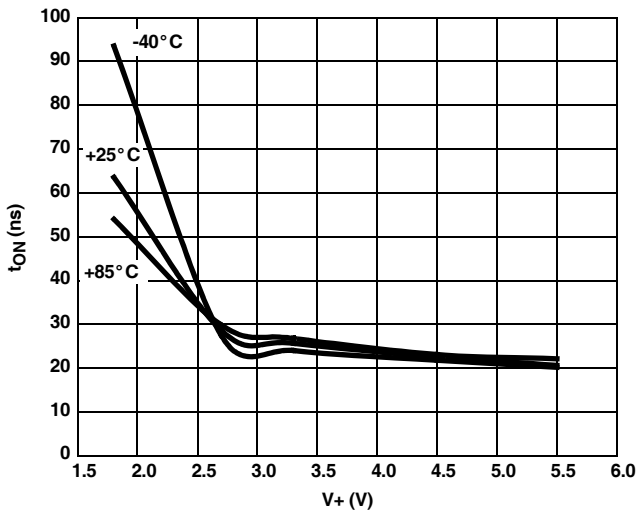

FIGURE 14. TURN-ON TIME vs SUPPLY VOLTAGE

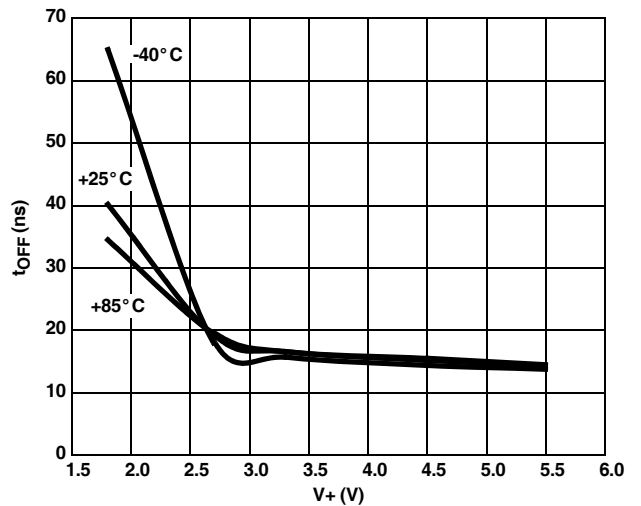

FIGURE 15. TURN-OFF TIME vs SUPPLY VOLTAGE

Typical Performance Curves $T_A = 25^\circ\text{C}$, Unless Otherwise Specified (Continued)

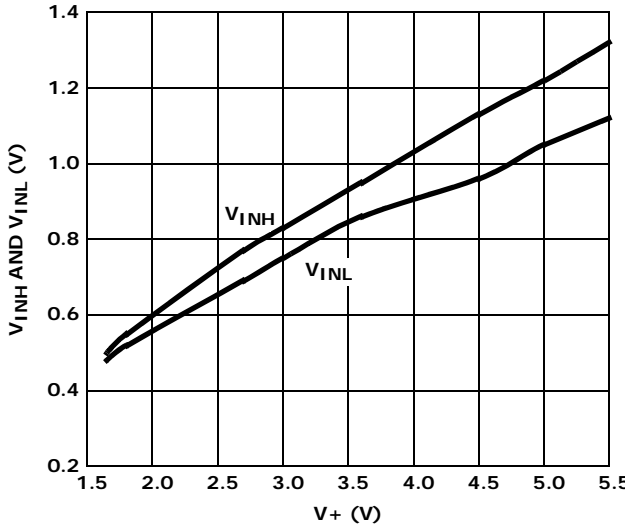

FIGURE 16. DIGITAL SWITCHING POINT vs SUPPLY VOLTAGE

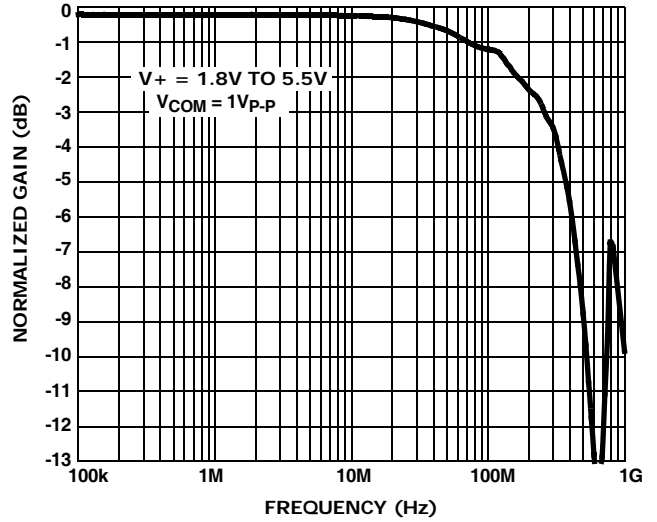

FIGURE 17. FREQUENCY RESPONSE

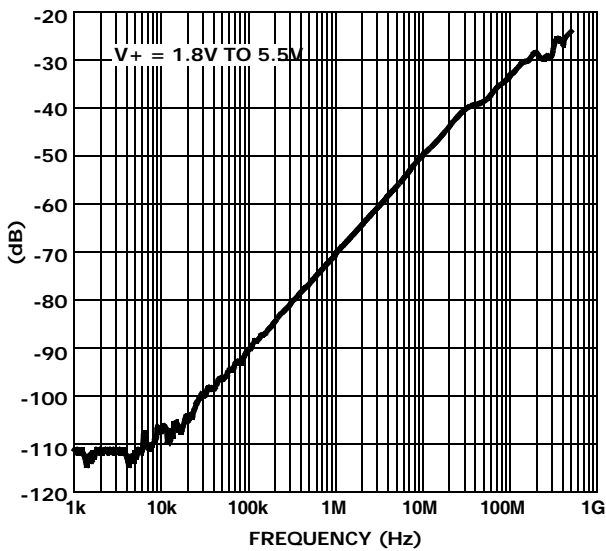

FIGURE 18. OFF-ISOLATION

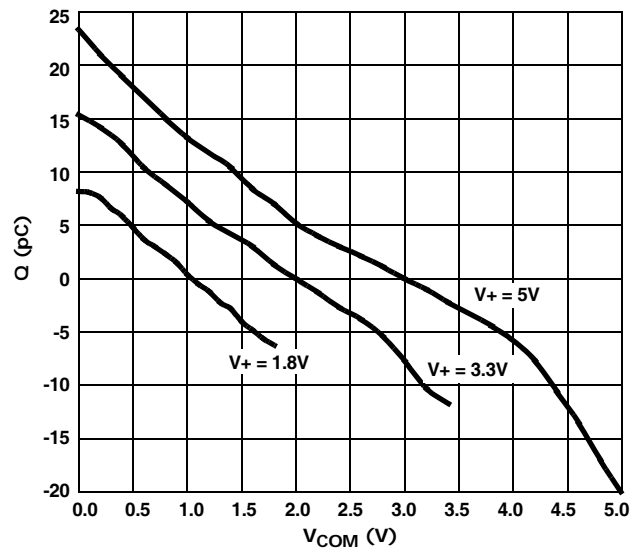

FIGURE 19. CHARGE INJECTION vs SWITCH VOLTAGE

Die Characteristics

SUBSTRATE POTENTIAL (POWERED UP):

GND

TRANSISTOR COUNT:

PROCESS:

Submicron CMOS

Ultra Thin Dual Flat No-Lead Plastic Package (UTDFN)

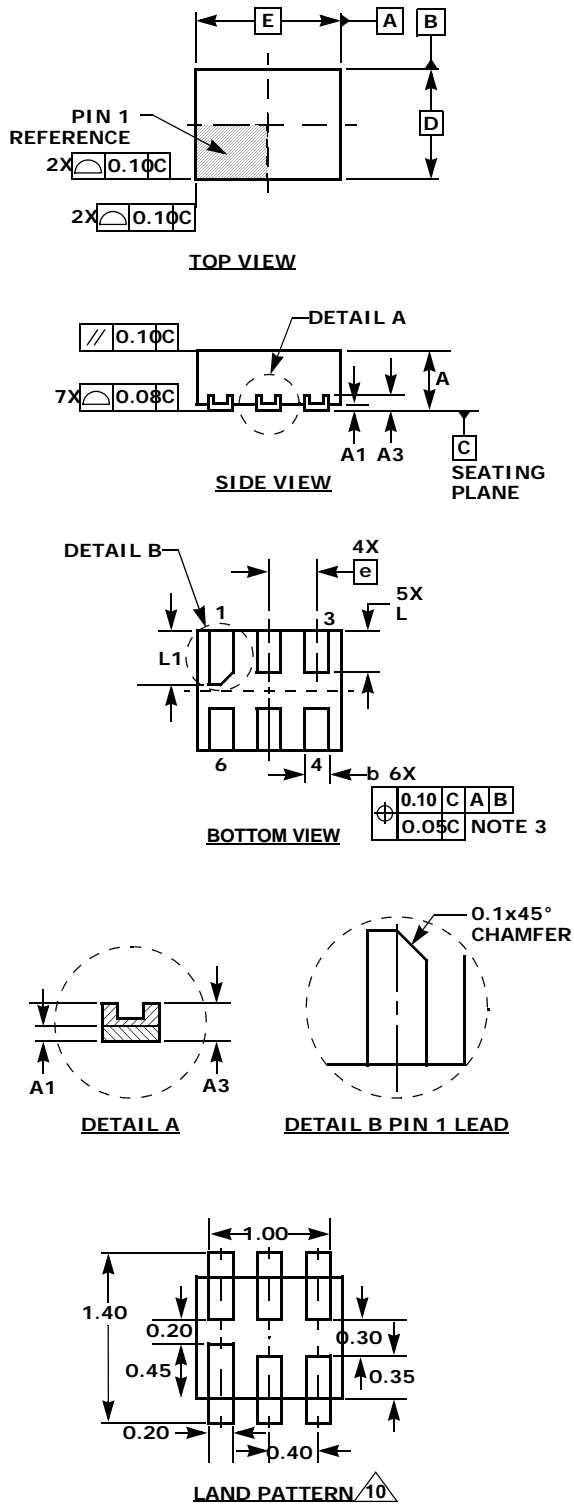

L6.1.2x1.0A

6 LEAD ULTRA THIN DUAL FLAT NO-LEAD PLASTIC PACKAGE

SYMBOL	MILLIMETERS			NOTES
	MIN	NOMI - NAL	MAX	
A	0.45	0.50	0.55	-
A1	-	-	0.05	-
A3	0.127 REF			-
b	0.15	0.20	0.25	5
D	0.95	1.00	1.05	-
E	1.15	1.20	1.25	-
e	0.40 BSC			-
L	0.30	0.35	0.40	-
L1	0.40	0.45	0.50	-
N	6			2
Ne	3			3
θ	0	-	12	4

Rev. 2 8/06

NOTES:

1. Dimensioning and tolerancing conform to ASME Y14.5-1994.
2. N is the number of terminals.
3. Ne refers to the number of terminals on E side.
4. All dimensions are in millimeters. Angles are in degrees.
5. Dimension b applies to the metallized terminal and is measured between 0.15mm and 0.30mm from the terminal tip.
6. The configuration of the pin #1 identifier is optional, but must be located within the zone indicated. The pin #1 identifier may be either a mold or mark feature.
7. Maximum package warpage is 0.05mm.
8. Maximum allowable burrs is 0.076mm in all directions.
9. JEDEC Reference MO-255.
10. For additional information, to assist with the PCB Land Pattern Design effort, see Intersil Technical Brief TB389.

SOT-23 Package Family

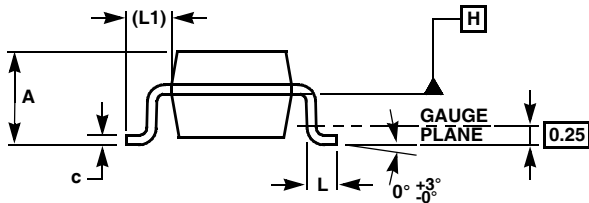
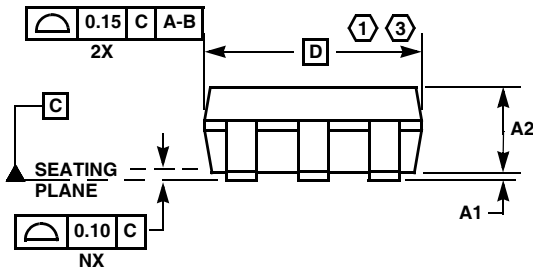
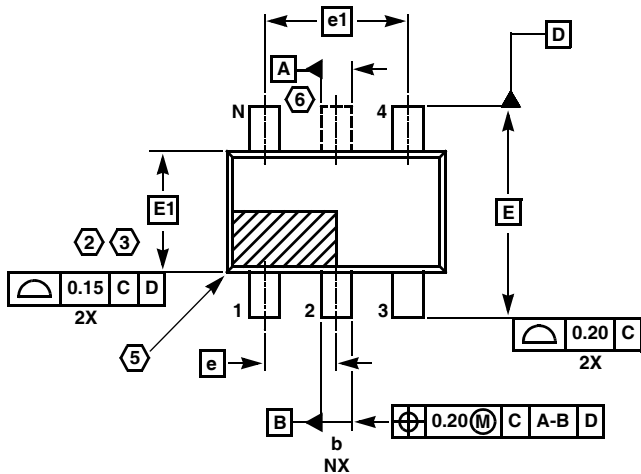

MDP0038

SOT-23 PACKAGE FAMILY

SYMBOL	MILLIMETERS		TOLERANCE
	SOT23-5	SOT23-6	
A	1.45	1.45	MAX
A1	0.10	0.10	±0.05
A2	1.14	1.14	±0.15
b	0.40	0.40	±0.05
c	0.14	0.14	±0.06
D	2.90	2.90	Basic
E	2.80	2.80	Basic
E1	1.60	1.60	Basic
e	0.95	0.95	Basic
e1	1.90	1.90	Basic
L	0.45	0.45	±0.10
L1	0.60	0.60	Reference
N	5	6	Reference

Rev. F 2/07

NOTES:

1. Plastic or metal protrusions of 0.25mm maximum per side are not included.
2. Plastic interlead protrusions of 0.25mm maximum per side are not included.
3. This dimension is measured at Datum Plane "H".
4. Dimensioning and tolerancing per ASME Y14.5M-1994.
5. Index area - Pin #1 I.D. will be located within the indicated zone (SOT23-6 only).
6. SOT23-5 version has no center lead (shown as a dashed line).

For additional products, see www.intersil.com/product_tree

Intersil products are manufactured, assembled and tested utilizing ISO9000 quality systems as noted in the quality certifications found at www.intersil.com/design/quality

Intersil products are sold by description only. Intersil Corporation reserves the right to make changes in circuit design, software and/or specifications at any time without notice. Accordingly, the reader is cautioned to verify that data sheets are current before placing orders. Information furnished by Intersil is believed to be accurate and reliable. However, no responsibility is assumed by Intersil or its subsidiaries for its use; nor for any infringements of patents or other rights of third parties which may result from its use. No license is granted by implication or otherwise under any patent or patent rights of Intersil or its subsidiaries.

For information regarding Intersil Corporation and its products, see www.intersil.com

X-ON Electronics

Largest Supplier of Electrical and Electronic Components

Click to view similar products for [Analog Switch ICs](#) category:

Click to view products by [Renesas](#) manufacturer:

Other Similar products are found below :

[PI5A100QEX](#) [DG9233EDY-GE3](#) [NLAS4684FCTCG](#) [NLAS5223BLMNR2G](#) [NLV74HC4066ADR2G](#) [MC74HC4067ADTG](#)
[NLX2G66DMUTCG](#) [NS5A4684SMNTAG](#) [732480R](#) [733995E](#) [425541DB](#) [425528R](#) [099044FB](#) [FSA221UMX](#) [MAX4888ETI+T](#)
[NLAS5123MNR2G](#) [NLAS7222AMTR2G](#) [MAX14807ECB+](#) [MAX4968ECM+](#) [PI5A4157CEX](#) [NLV14066BDG](#) [LC78615E-01US-H](#)
[PI5A4599BCEX](#) [PI5A3157BZUEX](#) [NLAS4717EPFCT1G](#) [PI5A3167CCEX](#) [MAX4744ELB+T](#) [MAX4802ACXZ+](#) [SLAS3158MNR2G](#)
[PI5A392AQE](#) [MAX4744HELB+T](#) [PI5A4157ZUEX](#) [MC74HC4067ADTR2G](#) [PI5A4158ZAEX](#) [PI5A3166TAEX](#) [MAX4901EBL+T](#)
[MAX14510EEVB+T](#) [PI3A3899ZTEX](#) [MAX4996ETG+T](#) [MAX4889AETO+T](#) [MAX14508EEVB+T](#) [MAX4701ETE+T](#) [MAX4996LETG+T](#)
[NLX2G66FCTAG](#) [TMUX136RSER](#) [HV2605FG-G](#) [DG302BDJ-E3](#) [ADG741BKSZ-REEL](#) [ADG742BKSZ5-REEL7](#) [PI5A100WE](#)