

ISL58315

High Speed Triple Laser Diode Drivers

FN7543

Rev 0.00

September 30, 2011

The ISL58315 is a high-speed, triple-output laser diode driver (LDD) for laser scanning projector systems, which require three channels modulated at high speed with independent current control.

Each output channel provides laser-independent current control for threshold and color DACs. Separate scale DACs allow independent scaling of both threshold and color DAC output values. This allows control of projector brightness and can be used to simplify automatic power calibration (APC) for laser-based systems.

Pixel data information is transferred through the LDD's high-speed 10-bit or 15-bit parallel video interface. Three parallel interface modes provide flexibility and allow users a trade-off among speed, power and bus width. Pixel data employs a double data rate scheme, allowing video data to be transferred using both clock edges.

Applications

- Laser-based Pico Projectors
- RGB Scanning and Field-based laser projection systems
- Generic laser-based applications requiring multiple, independently controlled lasers

Related Literature

- See application block diagram for Pico Projector (MEMS) at: <http://www.intersil.com/applications/PicoProjector%28MEMS%29.asp>

Features

- High-speed, triple-output laser diode driver supporting up to 720-pixel HD resolution
- Up to 1A of peak current output
- Fast output switching speeds with pulse rise/fall times of 1ns to 2ns for crisp pixels
- Intersil patented laser voltage sampler function provides dynamic power management capability to dramatically minimize system power
- Intersil patented SmartLinearizer™ DAC feature provides a linear transfer function (input video code to green laser output), eliminating the need for DSP controller processing algorithms required for non-linear green lasers
- Flexible 10-bit or Intersil patented 15-bit RGB pixel input formats supported to reduce speed and power. 300MHz maximum data Input rate supported for 10-bit RGB mode
- Blanking time power reduction reduces LDD current consumption to 3mA typical
- Programmable return-to-zero (RTZ) function provides maximum flexibility
- Integrated heater function for SHG green lasers reduces external components
- Single 3.3V supply and 1.8V video interface compatible for low power

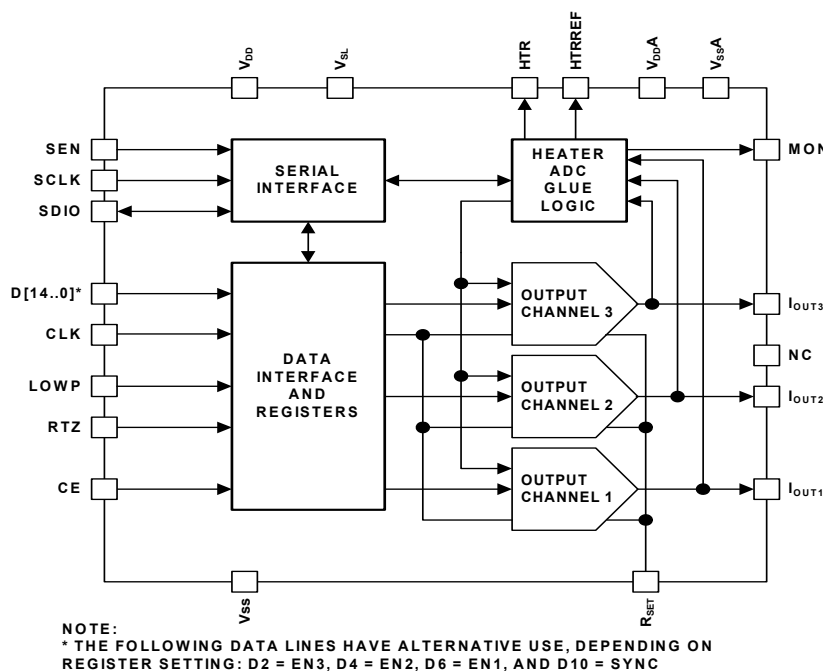

FIGURE 1. BLOCK DIAGRAM

© Copyright Intersil Americas LLC 2011. All Rights Reserved.
All trademarks and registered trademarks are the property of their respective owners.

For additional products, see www.intersil.com/en/products.html

Intersil products are manufactured, assembled and tested utilizing ISO9001 quality systems as noted in the quality certifications found at www.intersil.com/en/support/qualandreliability.html

Intersil products are sold by description only. Intersil may modify the circuit design and/or specifications of products at any time without notice, provided that such modification does not, in Intersil's sole judgment, affect the form, fit or function of the product. Accordingly, the reader is cautioned to verify that datasheets are current before placing orders. Information furnished by Intersil is believed to be accurate and reliable. However, no responsibility is assumed by Intersil or its subsidiaries for its use; nor for any infringements of patents or other rights of third parties which may result from its use. No license is granted by implication or otherwise under any patent or patent rights of Intersil or its subsidiaries.

For information regarding Intersil Corporation and its products, see www.intersil.com

X-ON Electronics

Largest Supplier of Electrical and Electronic Components

Click to view similar products for [Laser Drivers](#) category:

Click to view products by [Renesas](#) manufacturer:

Other Similar products are found below :

[AXXSATADVDRWROM937575 937575](#) [ADN2872ACPZ](#) [AD9665ACPZ-REEL7](#) [ADN2830ACPZ32](#) [ADN2841ACPZ-48](#) [ADN2847ACPZ-32](#) [ADN2871ACPZ](#) [ADN2841ACPZ-32](#) [HMC7144LC4](#) [HMC7144LC4TR](#) [HMC7150LP3DE](#) [HMC7810ALC3](#) [DS1873T+](#) [DS1874T+](#) [MAX3946ETG+T](#) [MAX3740AETG+T](#) [MAX3735AETG+T](#) [MAX3643ETG+T](#) [MAX3646ETG+](#) [MAX3656ETG+](#) [MAX3740AETG+](#) [MAX3949ETE+](#) [MAX3949ETE+T](#) [MAX3736ETE+T](#) [MAX3869ETJ](#) [MAX3798ETJ+](#) [MAX3737ETJ+](#) [DS1863E](#) [SY88422LMG](#) [MAX3669EHJ](#) [SY88992LMG-TR](#) [SY84782UMG](#) [SY88022ALMG](#) [SY88992LMG](#) [SY88236LMG](#) [SY88432LMG-TR](#) [SY88432LMG](#) [ONET1151LRGET](#) [ONET1151PRGTT](#) [ONET4201LDRGER](#) [ONET4201LDRGET](#) [ONET4211LDRGET](#) [ONET1101LRGER](#) [ONET1151LRGER](#) [ONET8501VRGPT](#) [MAX3948ETE](#) [MAX3946ETG+](#) [MAX3996CTP+](#) [MAX24002TL+](#) [DS1864T+](#)