

ISL8130EVAL3Z

Evaluation Board - Sepic Converter

AN1771
Rev 1.00
August 7, 2012

Introduction

ISL8130EVAL3Z is a sepic converter, which features the universal PWM controller, ISL8130. The evaluation board delivers 10V output at 2A. All the necessary components are within the 1.78" x 1.24" PCB area.

The ISL8130 is designed to drive N-Channel MOSFETs in a synchronous rectified buck topology for up to 25A instant MOSFET current and can be configured for boost, buck/boost and sepic converters as well. The ISL8130 integrates control, output adjustment, monitoring and protection functions into a single package. The ISL8130 provides simple, voltage mode control with fast transient response.

This application note describes how to use the ISL8130 to generate V_{OUT} from power supply of voltage either higher or lower than the V_{OUT} .

Evaluation Board Specifications

TABLE 1. EVALUATION BOARD ELECTRICAL SPECIFICATIONS

SPEC	DESCRIPTION	MIN	TYP	MAX	UNIT
V_{IN}	Board Input Range	5.6	10	16	V
IOC	Input Current	5			A
V_{OUT}	$I_{OUT} = 0A$	9.5	10	10.5	V
I_{OUT}	$V_{IN} = 5.6V$	2			A
η	$V_{IN} = 5.6V, I_{OUT} = 2A$		88.6		%
η	$V_{IN} = 8.4V, I_{OUT} = 2A$		90.3		%

Recommended Equipment

The following equipment is recommended for evaluation:

- 0V to 20V power supply with 10A source current capability
- Electronic load capable of sinking 2A @ 20V
- Digital Multi meters (DMMs)
- 100MHz Quad-Trace Oscilloscope

Features

- Operates From:
 - 4.5V to 5.5V Input for 5V Input
 - 5.5V to 16V Input
- Resistor-Selectable Switching Frequency from 100kHz to 1.4MHz
- Voltage Margining and External Reference Tracking Modes
- Kelvin Current Sensing
 - Upper MOSFET $r_{DS(ON)}$ for Current Sensing for Buck and Buck/Boost Converter
 - Precision Resistor/Inductor DCR for Boost and Sepic Converter
- Extensive Protection Functions:
 - Overvoltage, Overcurrent, Undervoltage
- Power Good Indicator

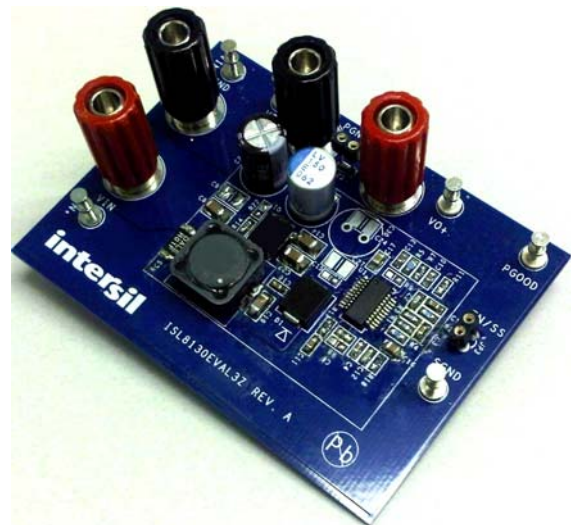

FIGURE 1. ISL8130EVAL3Z TOP VIEW

TABLE 2. RECOMMENDED COMPONENT SELECTION FOR QUICK EVALUATION

V_{OUT} (V)	R4 (k Ω)	V_{IN} (V)	I_{OUT} (A)	$F_{SW}(kHz)/R_5(k\Omega)$	MOSFET	FORWARD DIODE	INDUCTOR (L, ISAT MEASURED IN PARALLEL)
7	9.53	5.6 to 14	2	500kHz/28.7k Ω	BS0051N03 MS	SL43	4.7 μ H, 6A
10	6.34	5.6 to 16	2	500kHz/28.7k Ω	BSC059N04 LS	SL42	4.7 μ H, 7A
12	5.23	5.6 to 14	2	500kHz/28.7k Ω	BSC057N03 LS	SL42	4.7 μ H, 9A

NOTES:

1. Please select the output capacitor with a voltage rating higher than the output.
2. Please contact [Intersil Sales](#) for assistance.

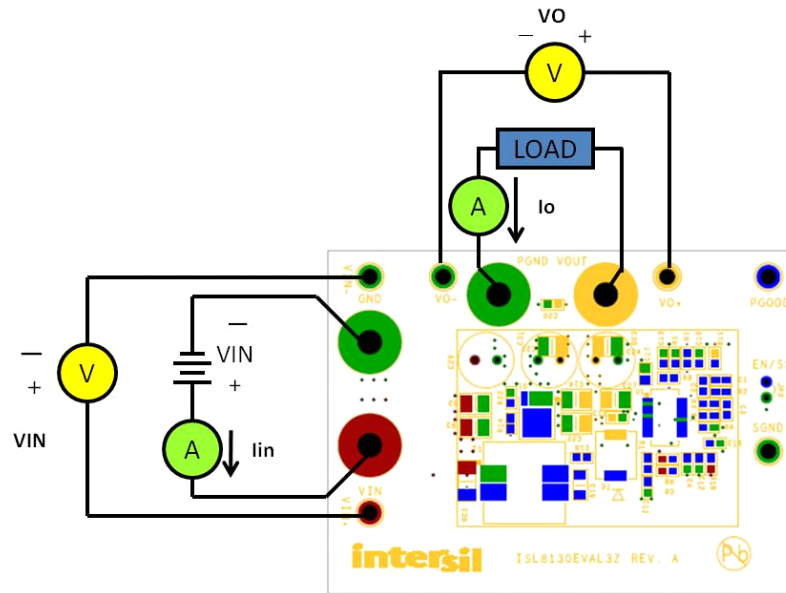

FIGURE 2. ISL8130EVAL3Z TEST SET-UP

Quick Test Setup

1. Ensure that the Evaluation board is correctly connected to the power supply and the electronic load prior to applying any power. Please refer to Figure 2 for proper set-up.
2. Leave JP3 in the open position.
3. Turn on the power supply; $V_{IN} < 16V$.
4. Adjust input voltage V_{IN} within the specified range and observe output voltage. The output voltage variation should be within 5%.
5. Adjust load current within 2A. The output voltage variation should be within 5%.
6. Use oscilloscope to observe output ripple voltage and phase node ringing. For accurate measurement, please refer to Figure 3 for proper probe set-up.
7. Optimization. Please refer to Table 2 on page 1 for optimization recommendation.
8. For 5V input applications, please tie the VCC5V to VIN and do not allow V_{IN} to go above 5.5V.

NOTE: Test points: VIN+, VIN-, VO+ and VO- are for voltage measurement only. Do not allow high current through these test points.

Probe Set-up

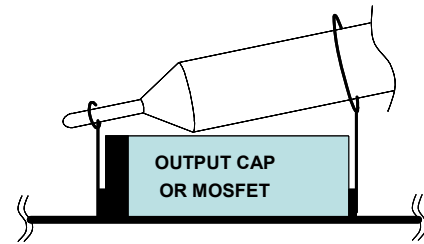

FIGURE 3. OSCILLOSCOPE PROBE SET-UP

VOUT Setting

The output voltage is set by the resistor divider, R_4 and R_1 .

$$V_{OUT} = \frac{R_4 + R_1}{R_4} \times 0.6V \quad (\text{EQ. 1})$$

Resistor R_{11} is a resistor jumper for loop gain measurement. It is recommended to set $R_{11} = 50\Omega$ for loop gain measurement.

Component Selection

Component Voltage Stress

The controller, ISL8130, the input capacitors and the flying capacitors, C18 and C19, see the input voltage. MOSFET and forward diode see the voltage stress of $V_{IN} + V_{OUT}$.

Duty Cycle Calculation

The duty cycle of the sepic converter can be estimated using Equation 2.

$$D = \frac{V_{OUT} + V_F}{V_{IN} + V_{OUT} + V_F} \quad (\text{EQ. 2})$$

Where: V_F is the forward voltage of the diode, D1.

Given:

$$V_{IN} = 8.4V, V_{OUT} = 10V, V_F = 0.5V$$

We have nominal duty cycle of 44.4%.

Maximum duty cycle and minimum duty cycle can be estimated by Equation 3 and Equation 4 respectively.

$$D_{max} = \frac{V_{OUT} + V_F}{V_{INmin} + V_{OUT} + V_F} \quad (\text{EQ. 3})$$

$$D_{min} = \frac{V_{OUT} + V_F}{V_{INmax} + V_{OUT} + V_F} \quad (\text{EQ. 4})$$

Coupled Inductor Selection

A coupled inductor with 1:1 turns ratio is recommended for sepic converter. Such a coupled inductor is specified in two ratings; the parallel ratings and the series ratings. In this application note, inductor parameters refers to the parallel rating unless otherwise noted.

It is recommended to select inductor so that the ripple current to DC current ratio is between 30% to 50%. For low-core-loss magnetic material, higher ripple ratio would ease the compensation design and help to reduce the size of the inductor.

Please refer to Equation 5 for recommended inductor value:

$$L_P = \frac{V_{IN}}{\Delta i_R \times I_{Omax} \times F_{SW}} \times D \times (1 - D) \quad (\text{EQ. 5})$$

Where D is the duty cycle, Δi_R is the inductor ripple ratio, I_{Omax} is the maximum load current. With $I_{Omax} = 2A$, $F_{SW} = 500kHz$, $\Delta i_R = 40\%$. The recommended inductance is $5.18\mu H$. The DC magnetizing current of the coupled inductor can be estimated by:

$$I_{INDmax} = \frac{I_{Omax}}{1 - D_{max}} \quad (\text{EQ. 6})$$

The peak magnetizing current is:

$$I_{INPK} = I_{INDmax} + \frac{1}{2} \cdot \frac{(V_{OUT} + V_F) \cdot (1 - D_{max})}{L_P \cdot F_{SW}} \quad (\text{EQ. 7})$$

The inductor should be of saturation current higher than that calculated by Equation 7. DRC127-4R7 is selected with actual inductance of $4.7\mu H$.

It is recommended to select inductor with saturation current higher than the maximum overcurrent threshold. Please refer to "Current Sensing" on page 3 for details.

Current Sensing

For accurate overcurrent detection, it is recommended to set the voltage across the current sensing resistor, R_{CS} higher than 50mV. Taking variation into consideration, when precision current sensing resistor is used, $R_{SEN} = 665\Omega$.

The DC current of the output winding can be estimated by:

$$I_{INWIND} = I_{Omax} \cdot \frac{V_{OUT} + V_F}{V_{INmin}} \quad (\text{EQ. 8})$$

The OC threshold should be higher than the peak input winding current at maximum load current. The maximum peak inductor usually occurs at V_{INmin} and can be calculated by Equation 9.

$$I_{INPK} = I_{Omax} \cdot \frac{V_{OUT} + V_F}{V_{INmin}} + \frac{1}{4} \cdot \frac{(V_{OUT} + V_F) \cdot (1 - D_{max})}{L_P \cdot F_{SW}} \quad (\text{EQ. 9})$$

Refer to Equation 10 for R_{CS} calculation.

$$R_{CS} < \frac{R_{SEN} \times I_{OCSET(min)}}{I_{INPK}} \quad (\text{EQ. 10})$$

Where: I_{OCSET} is the OCSET pin sinking current for overcurrent detection. The $I_{OCSET(min)} = 80\mu A$.

The maximum overcurrent threshold can be calculated by Equation 11.

$$I_{OCmax} = \frac{R_{SEN} \times I_{OCSET(max)}}{R_{CS}} \quad (\text{EQ. 11})$$

Where $I_{OCSET(max)} = 120\mu A$. When input winding current reaches the OC threshold, the inductor peak magnetizing current can be estimated by Equation 12.

$$I_{OCMAG} = \frac{I_{OCmax}}{D_{min}} - \frac{1}{4} \cdot \frac{(V_{OUT} + V_F) \cdot (1 - D_{min})}{L_P \cdot F_{SW}} \cdot \frac{1 - 2 \cdot D_{min}}{D_{min}} \quad (\text{EQ. 12})$$

The R_{CS} should be rated for the power loss at the maximum OC trip point.

For most accurate current sensing setting, please use Kelvin connection for OCSET and ISEN pins. Please refer to Figure 4 for reference.

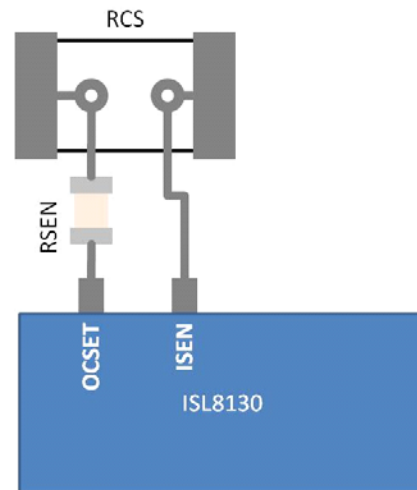

FIGURE 4. ISL8130 CURRENT SENSING LAYOUT EXAMPLE

Output Capacitors

It is recommended to use a combination of aluminum capacitors with high capacitance and low ESR ceramic capacitors at the output for optimum ripple and load transient performance.

The low ESL and ESR ceramic capacitors should be placed close to the MOSFET and diode. The loop formed by the MOSFET, the flying capacitors, C18 and C19, the forward diode and the output ceramic capacitors should be minimized as short as possible.

When selecting the output capacitors, there are two important requirements: the ripple current and the stability.

The output RMS current worst case occurs at V_{INmin} and maximum load. See Equation 13 for output ripple current calculation:

$$I_{ORMS} = I_{OUT} \cdot \sqrt{\frac{1}{1-D_{max}}} \quad (\text{EQ. 13})$$

Given:

$$V_{OUT} = 10V, I_{OUT} = 2A, V_{INmin} = 5.6V$$

$$D_{max} = 65.7\%$$

We have:

$$I_{ORMS} = 3.417A$$

For applications with $F_{SW} < 1\text{MHz}$, it is still rule of thumb that the aluminum electrolytic capacitors take the ripple current. Please select electrolytic capacitors with ripple current greater than the maximum I_{ORMS} , as calculated by Equation 13.

The other important factor is stability. The right-half-plane zero, f_{RHP} of a sepic converter imposes a big challenge for stability. It is recommended to set cross over frequency below the f_{RHP} and above the boost converter natural resonant frequency, f_N . It is recommended to use sufficient output capacitors so that the f_N is much lower than f_{RHP} . Equation 14 is provided for total output capacitance estimation.

$$C_{out} > \left(\frac{I_{Omax}}{V_{INmin}} \right)^2 \cdot L_P \cdot 400 \quad (\text{EQ. 14})$$

For right-half-plane zero calculation, f_{RHP} :

$$f_{RHP} = \frac{V_{in} \cdot (1-D)}{2\pi \cdot I_{OUT} \cdot L_P} \quad (\text{EQ. 15})$$

For sepic converter natural resonant frequency, f_N :

$$f_N = \frac{1-D}{2\pi \cdot \sqrt{C_{OUT} \cdot L_P}} \quad (\text{EQ. 16})$$

Flying Capacitors

High ripple current rated ceramic capacitors are preferred for the flying capacitors. The flying capacitor ripple current is at maximum when $V_{IN} = V_{INmin}$ and can be estimated by Equation 17:

$$I_{FLYRMS} = I_{OUT} \cdot \sqrt{\frac{V_{OUT} + V_F}{V_{INmin}}} \quad (\text{EQ. 17})$$

Given:

$$V_{OUT} = 10V, I_{OUT} = 2A, V_{INmin} = 5.6V$$

We have:

$$I_{FLYRMS} = 2.74A$$

Please select flying capacitor with ripple current higher than I_{FLYRMS} . The flying capacitor would also resonate with the leakage inductor of the coupled inductor. It is recommended to use sufficient C_{FLY} so that the resonating frequency be lower than half of the switching frequency.

The leakage inductance can be measured in the setup shown in Figure 5.

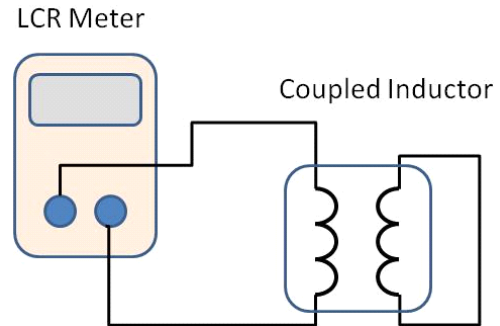

FIGURE 5. LEAKAGE INDUCTANCE MEASUREMENT SETUP

Equation 18 gives the recommended C_{FLY} :

$$C_{FLY} > \left(\frac{1}{\pi \cdot F_{SW}} \right)^2 \cdot \frac{1}{L_S} \quad (\text{EQ. 18})$$

Given $L_S = 0.1\mu\text{H}$ and $F_{SW} = 500\text{kHz}$, the recommended C_{FLY} should be greater than $4.4\mu\text{F}$. When ceramic capacitors are used, attention should be paid to the DC degrading characteristic. Please contact capacitor vendor for more details.

Typical Performance Curves

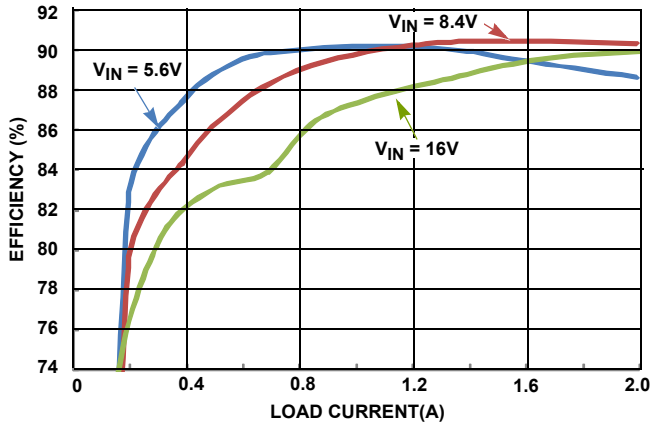

FIGURE 6. EFFICIENCY vs LOAD CURRENT

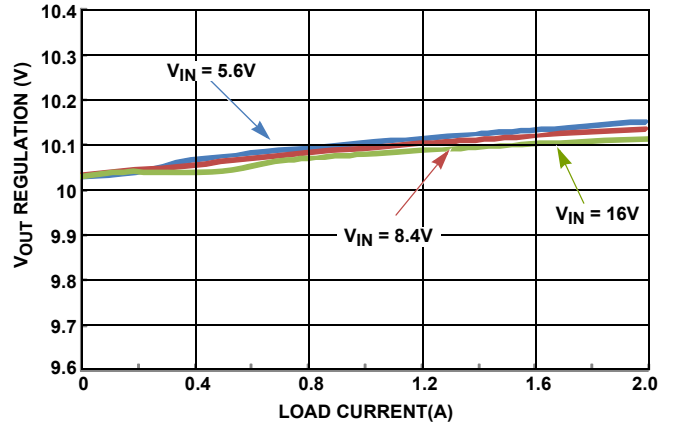

FIGURE 7. V_{OUT} LOAD REGULATION

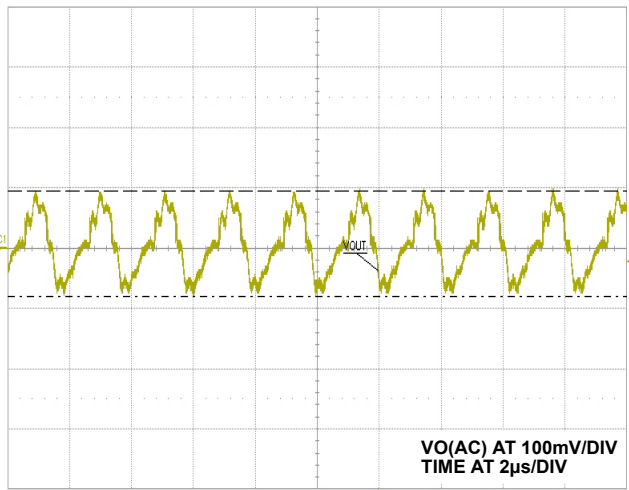

FIGURE 8. OUTPUT RIPPLE ($V_{IN} = 5.6V$, LOAD = 2A, 20MHz BW)

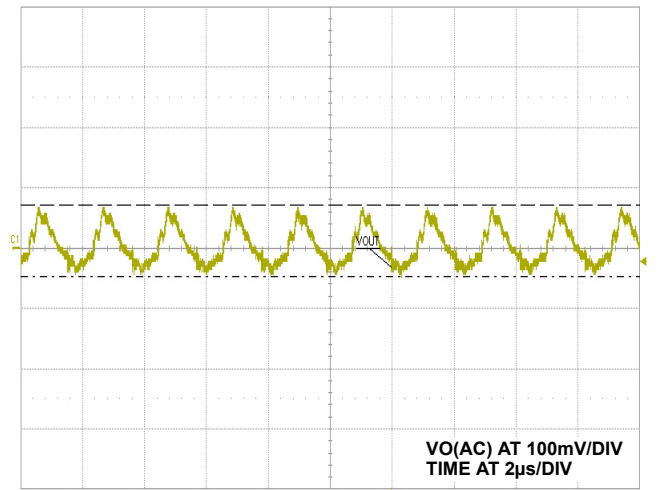

FIGURE 9. OUTPUT RIPPLE ($V_{IN} = 8.4V$, LOAD = 2A, 20MHz BW)

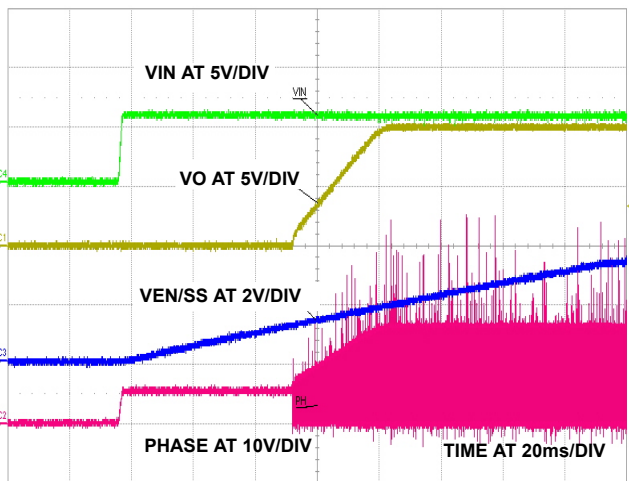

FIGURE 10. SOFT-START ($V_{IN} = 5.6V$, $C_{SS} = 0.47\mu F$)

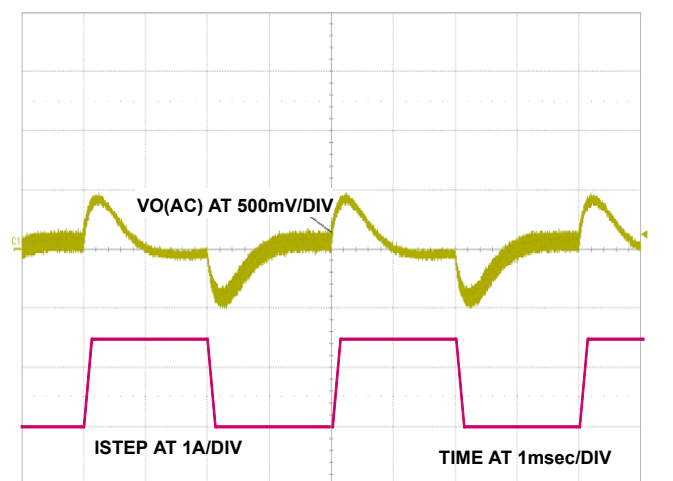

FIGURE 11. LOAD TRANSIENT ($V_{IN} = 5.6V$, LOADSTEP FROM 0.5A to 1.5A)

Typical Performance Curves (Continued)

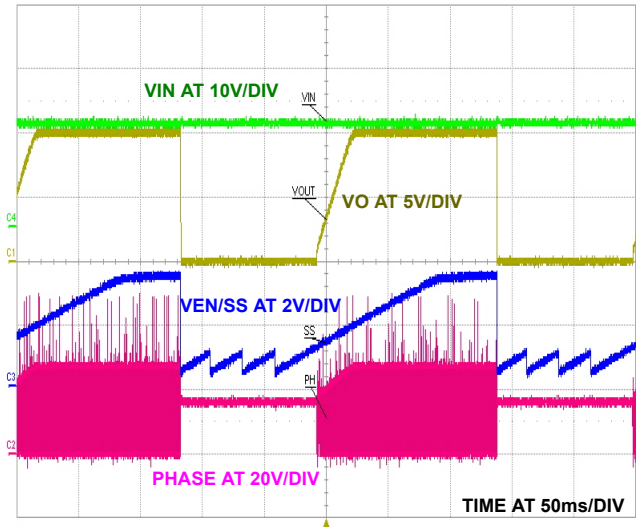

FIGURE 12. OVERCURRENT PROTECTION ($V_{IN} = 16V$, $I_{LOAD} = 6.6A$)

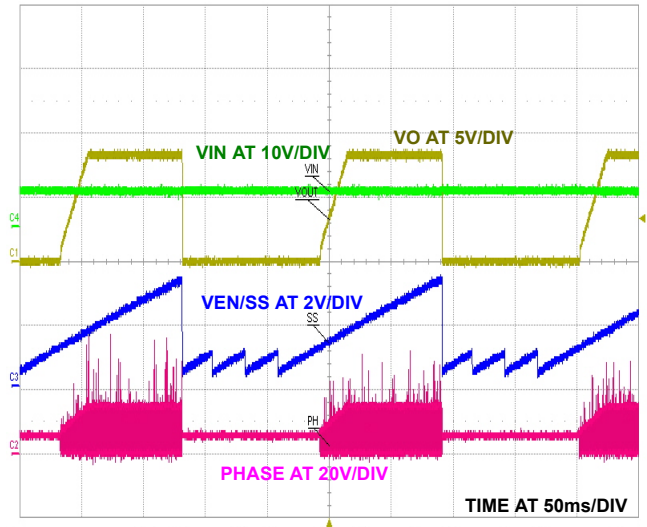
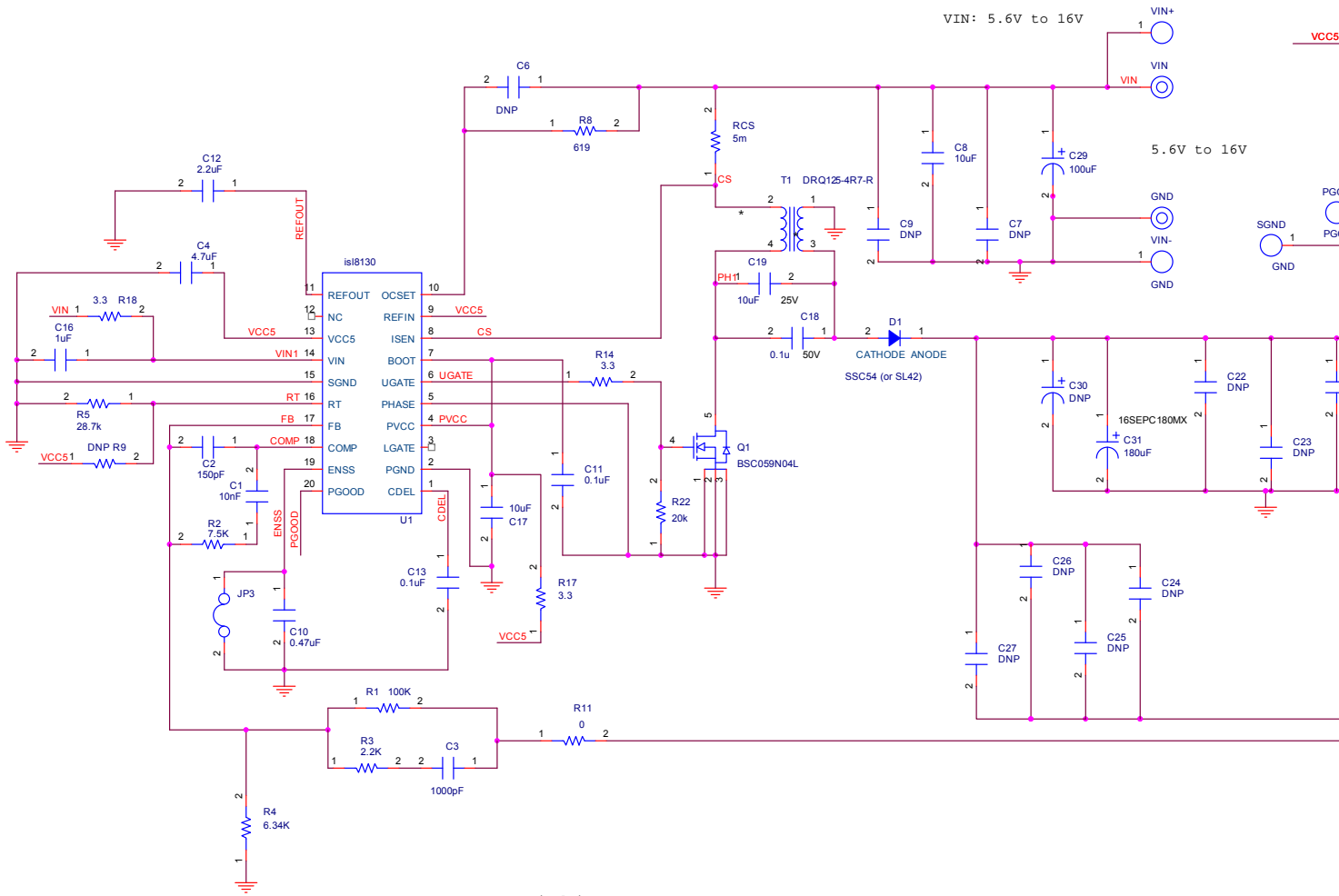

FIGURE 13. OVERCURRENT PROTECTION ($V_{IN} = 5.6V$, $I_{LOAD} = 3.1A$)

ISL8130EVAL3Z Schematic



Disclaimer: THIS EVALUATION BOARD AND MATERIALS ARE PROVIDED 'AS-IS' FOR EVALUATION PURPOSES ONLY. INTERSIL CORPORATION AND ITS SUBSIDIARIES ('INTERISL') DISCLAIM ALL WARRANTIES, INCLUDING WITHOUT LIMITATION FITNESS FOR A PARTICULAR PURPOSE AND MERCHANTABILITY. Intersil provides the evaluation platform and design proposals to help our customers to develop products. However, factors beyond Intersil's control, including without limitation component variations, temperature changes and PCB layout, could significantly affect Intersil product performance. It remains the customers' responsibility to verify the actual circuit performance.

Bill of Materials

ITEM	QTY	REFERENCE	VALUE	DESCRIPTION	PART #	VENDOR
1	1	C1	10nF	Ceramic CAP, NPO or COG, 50V, sm0603	Generic	Generic
2	1	C2	150pF	Ceramic CAP, NPO or COG, 50V, sm0603	Generic	Generic
3	1	C3	1000pF	Ceramic CAP, NPO or COG, 50V, sm0603	Generic	Generic
4	1	C4	4.7μF	Ceramic CAP, X5R, 10V, sm0603	Generic	Generic
5	4	C14, C19, C22, C8	10μF	Ceramic CAP, X5R, 25V, sm1206	Generic	Generic
6	1	C10	0.47μF	Ceramic CAP, X5R, 16V, sm0603	Generic	Generic
7	2	C11, C13	0.1μF	Ceramic CAP, X5R, 16V, sm0603	Generic	Generic
8	1	C12	2.2μF	Ceramic CAP, X5R, 16V, sm0603	Generic	Generic
9	2	C16, C20	1μF	Ceramic CAP, X5R, 16V, sm0603	Generic	Generic
10	1	C17	10μF	Ceramic CAP, X5R, 10V, sm0805	Generic	Generic
11	1	C18	0.1μF	Ceramic CAP, X5R, 50V, sm0805	Generic	Generic
12	1	C29	100μF	Alum Cap, 35V, Ripple Current > 300mA	EEU-FC1V101	Panasonics
13	1	C31	150μF	ALUM CAP, 25V	PLV1E151MDL1TD	Nichicon
14	1	D1		Schottky Diode, 40V, DO-214AB	SSC54	Vishay
15	1	Q1		Single Channel NFET, 40V	BSC059N04L	Infineon
16	1	RCS	10m	Precision RES, SM2010	PMR50HZPFU10L0	ROHM
17	1	R1	100k	Resistor, sm0603, 1%	Generic	Generic
18	1	R2	7.5k	Resistor, sm0603, 1%	Generic	Generic
19	1	R3	2.2k	Resistor, sm0603, 10%	Generic	Generic
20	1	R4	6.34k	Resistor, sm0603, 1%	Generic	Generic
21	1	R5	28.7k	Resistor, sm0603, 1%	Generic	Generic
22	1	R7	100k	Resistor, sm0603, 10%	Generic	Generic
23	1	R8	665	Resistor, sm0603, 1%	Generic	Generic
24	1	R11	0	Resistor, sm0603, 10%	Generic	Generic
25	3	R14, R17, R18	3.3	Resistor, sm0603, 10%	Generic	Generic
26	1	R22	20k	Resistor, sm0603, 1%	Generic	Generic
27	1	T1	4.7μH	1:1 Coupled Inductor	DRQ125-4R7-R	Cooper
28	1	U1		PWM Controller, 20L QSOP	ISL8130IAZ	Intersil
EVALUTION BOARD HARDWARE						
29	1	JP3		jumper_2pin	Generic	Generic
30	2	VOUT, VIN		Banana Jack (Red)	111-0703-002	Emerson
31	2	PGND, GND		Banana Jack (Black)	111-0703-001	Emerson
32	6	VIN+, VO+, VO-, VIN-, SGND, PGOOD		Test Point	1514-2	Keystone
OPTIONAL COMPONENTS						
33	8	C6, C7, C9, C15, C23, C24, C25, C26, C27, C30		DNP		

ISL8130EVAL3Z PCB Layout

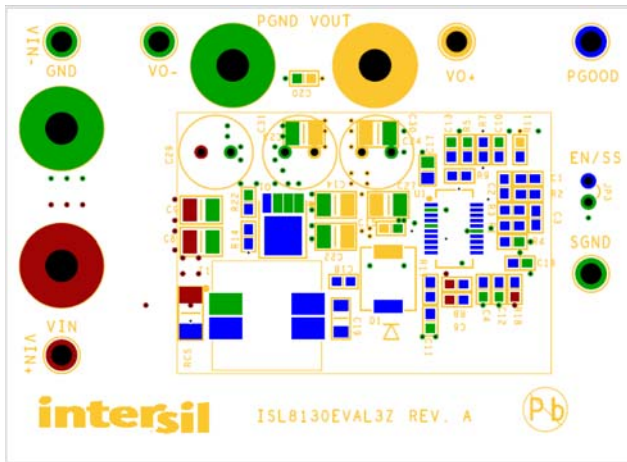

FIGURE 14. TOP SILKSCREEN

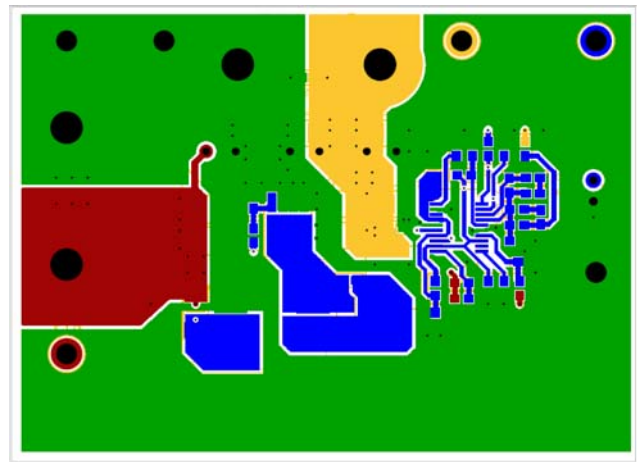

FIGURE 15. TOP LAYER

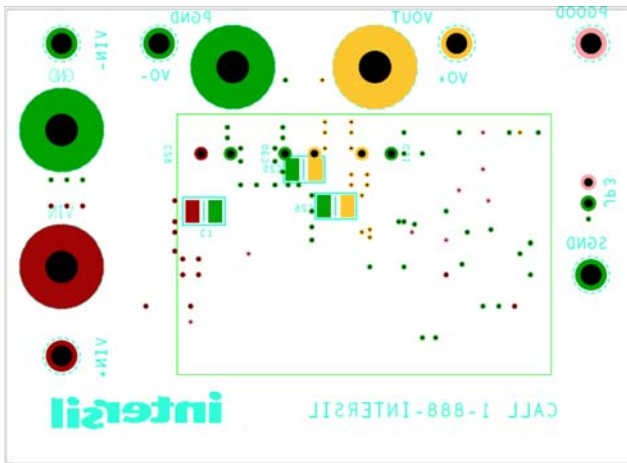

FIGURE 16. BOTTOM SILKSCREEN

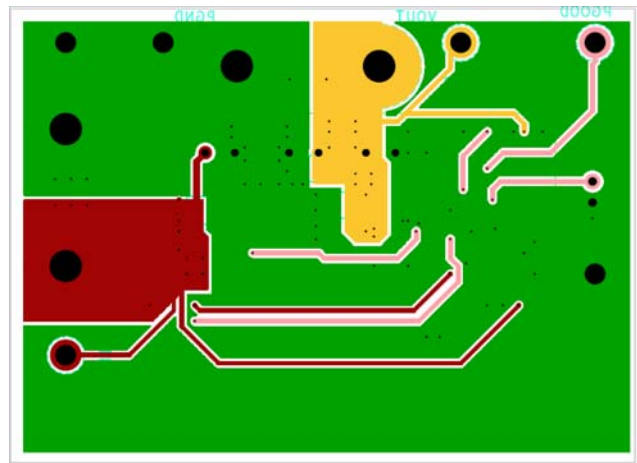

FIGURE 17. BOTTOM LAYER

Notice

1. Descriptions of circuits, software and other related information in this document are provided only to illustrate the operation of semiconductor products and application examples. You are fully responsible for the incorporation or any other use of the circuits, software, and information in the design of your product or system. Renesas Electronics disclaims any and all liability for any losses and damages incurred by you or third parties arising from the use of these circuits, software, or information.
2. Renesas Electronics hereby expressly disclaims any warranties against and liability for infringement or any other claims involving patents, copyrights, or other intellectual property rights of third parties, by or arising from the use of Renesas Electronics products or technical information described in this document, including but not limited to, the product data, drawings, charts, programs, algorithms, and application examples.
3. No license, express, implied or otherwise, is granted hereby under any patents, copyrights or other intellectual property rights of Renesas Electronics or others.
4. You shall not alter, modify, copy, or reverse engineer any Renesas Electronics product, whether in whole or in part. Renesas Electronics disclaims any and all liability for any losses or damages incurred by you or third parties arising from such alteration, modification, copying or reverse engineering.
5. Renesas Electronics products are classified according to the following two quality grades: "Standard" and "High Quality". The intended applications for each Renesas Electronics product depends on the product's quality grade, as indicated below.
"Standard": Computers; office equipment; communications equipment; test and measurement equipment; audio and visual equipment; home electronic appliances; machine tools; personal electronic equipment; industrial robots; etc.
"High Quality": Transportation equipment (automobiles, trains, ships, etc.); traffic control (traffic lights); large-scale communication equipment; key financial terminal systems; safety control equipment; etc.
Unless expressly designated as a high reliability product or a product for harsh environments in a Renesas Electronics data sheet or other Renesas Electronics document, Renesas Electronics products are not intended or authorized for use in products or systems that may pose a direct threat to human life or bodily injury (artificial life support devices or systems; surgical implantations; etc.), or may cause serious property damage (space system; undersea repeaters; nuclear power control systems; aircraft control systems; key plant systems; military equipment; etc.). Renesas Electronics disclaims any and all liability for any damages or losses incurred by you or any third parties arising from the use of any Renesas Electronics product that is inconsistent with any Renesas Electronics data sheet, user's manual or other Renesas Electronics document.
6. When using Renesas Electronics products, refer to the latest product information (data sheets, user's manuals, application notes, "General Notes for Handling and Using Semiconductor Devices" in the reliability handbook, etc.), and ensure that usage conditions are within the ranges specified by Renesas Electronics with respect to maximum ratings, operating power supply voltage range, heat dissipation characteristics, installation, etc. Renesas Electronics disclaims any and all liability for any malfunctions, failure or accident arising out of the use of Renesas Electronics products outside of such specified ranges.
7. Although Renesas Electronics endeavors to improve the quality and reliability of Renesas Electronics products, semiconductor products have specific characteristics, such as the occurrence of failure at a certain rate and malfunctions under certain use conditions. Unless designated as a high reliability product or a product for harsh environments in a Renesas Electronics data sheet or other Renesas Electronics document, Renesas Electronics products are not subject to radiation resistance design. You are responsible for implementing safety measures to guard against the possibility of bodily injury, injury or damage caused by fire, and/or danger to the public in the event of a failure or malfunction of Renesas Electronics products, such as safety design for hardware and software, including but not limited to redundancy, fire control and malfunction prevention, appropriate treatment for aging degradation or any other appropriate measures. Because the evaluation of microcomputer software alone is very difficult and impractical, you are responsible for evaluating the safety of the final products or systems manufactured by you.
8. Please contact a Renesas Electronics sales office for details as to environmental matters such as the environmental compatibility of each Renesas Electronics product. You are responsible for carefully and sufficiently investigating applicable laws and regulations that regulate the inclusion or use of controlled substances, including without limitation, the EU RoHS Directive, and using Renesas Electronics products in compliance with all these applicable laws and regulations. Renesas Electronics disclaims any and all liability for damages or losses occurring as a result of your noncompliance with applicable laws and regulations.
9. Renesas Electronics products and technologies shall not be used for or incorporated into any products or systems whose manufacture, use, or sale is prohibited under any applicable domestic or foreign laws or regulations. You shall comply with any applicable export control laws and regulations promulgated and administered by the governments of any countries asserting jurisdiction over the parties or transactions.
10. It is the responsibility of the buyer or distributor of Renesas Electronics products, or any other party who distributes, disposes of, or otherwise sells or transfers the product to a third party, to notify such third party in advance of the contents and conditions set forth in this document.
11. This document shall not be reprinted, reproduced or duplicated in any form, in whole or in part, without prior written consent of Renesas Electronics.
12. Please contact a Renesas Electronics sales office if you have any questions regarding the information contained in this document or Renesas Electronics products.
(Note 1) "Renesas Electronics" as used in this document means Renesas Electronics Corporation and also includes its directly or indirectly controlled subsidiaries.
(Note 2) "Renesas Electronics product(s)" means any product developed or manufactured by or for Renesas Electronics.

(Rev.4.0-1 November 2017)



SALES OFFICES

Renesas Electronics Corporation

<http://www.renesas.com>

Refer to "<http://www.renesas.com/>" for the latest and detailed information.

Renesas Electronics America Inc.
1001 Murphy Ranch Road, Milpitas, CA 95035, U.S.A.
Tel: +1-408-432-8888, Fax: +1-408-434-5351

Renesas Electronics Canada Limited
9251 Yonge Street, Suite 8309 Richmond Hill, Ontario Canada L4C 9T3
Tel: +1-905-237-2004

Renesas Electronics Europe Limited
Dukes Meadow, Millboard Road, Bourne End, Buckinghamshire, SL8 5FH, U.K
Tel: +44-1628-651-700, Fax: +44-1628-651-804

Renesas Electronics Europe GmbH
Arcadiastrasse 10, 40472 Düsseldorf, Germany
Tel: +49-211-6503-0, Fax: +49-211-6503-1327

Renesas Electronics (China) Co., Ltd.
Room 1709 Quantum Plaza, No.27 ZhichunLu, Haidian District, Beijing, 100191 P. R. China
Tel: +86-10-8235-1155, Fax: +86-10-8235-7679

Renesas Electronics (Shanghai) Co., Ltd.
Unit 301, Tower A, Central Towers, 555 Langao Road, Putuo District, Shanghai, 200333 P. R. China
Tel: +86-21-2226-0888, Fax: +86-21-2226-0999

Renesas Electronics Hong Kong Limited
Unit 1601-1611, 16/F., Tower 2, Grand Century Place, 193 Prince Edward Road West, Mongkok, Kowloon, Hong Kong
Tel: +852-2265-6688, Fax: +852-2886-9022

Renesas Electronics Taiwan Co., Ltd.
13F, No. 363, Fu Shing North Road, Taipei 10543, Taiwan
Tel: +886-2-8175-9600, Fax: +886-2-8175-9670

Renesas Electronics Singapore Pte. Ltd.
80 Bendemeer Road, Unit #06-02 Hyflux Innovation Centre, Singapore 339949
Tel: +65-6213-0200, Fax: +65-6213-0300

Renesas Electronics Malaysia Sdn.Bhd.
Unit 1207, Block B, Menara Amcorp, Amcorp Trade Centre, No. 18, Jln Persiaran Barat, 46050 Petaling Jaya, Selangor Darul Ehsan, Malaysia
Tel: +60-3-7955-9390, Fax: +60-3-7955-9510

Renesas Electronics India Pvt. Ltd.
No.777C, 100 Feet Road, HAL 2nd Stage, Indiranagar, Bangalore 560 038, India
Tel: +91-80-67208700, Fax: +91-80-67208777

Renesas Electronics Korea Co., Ltd.
17F, KAMCO Yangjae Tower, 262, Gangnam-daero, Gangnam-gu, Seoul, 06265 Korea
Tel: +82-2-558-3737, Fax: +82-2-558-5338

X-ON Electronics

Largest Supplier of Electrical and Electronic Components

Click to view similar products for [Power Management IC Development Tools](#) category:

Click to view products by [Renesas](#) manufacturer:

Other Similar products are found below :

[EVAL-ADM1168LQEBZ](#) [EVB-EP5348UI](#) [MIC23451-AAAYFL EV](#) [MIC5281YMME EV](#) [DA9063-EVAL](#) [ADP122-3.3-EVALZ](#) [ADP130-0.8-EVALZ](#) [ADP130-1.2-EVALZ](#) [ADP130-1.5-EVALZ](#) [ADP130-1.8-EVALZ](#) [ADP1714-3.3-EVALZ](#) [ADP1716-2.5-EVALZ](#) [ADP1740-1.5-EVALZ](#) [ADP1752-1.5-EVALZ](#) [ADP1828LC-EVALZ](#) [ADP1870-0.3-EVALZ](#) [ADP1871-0.6-EVALZ](#) [ADP1873-0.6-EVALZ](#) [ADP1874-0.3-EVALZ](#) [ADP1882-1.0-EVALZ](#) [ADP199CB-EVALZ](#) [ADP2102-1.25-EVALZ](#) [ADP2102-1.875EVALZ](#) [ADP2102-1.8-EVALZ](#) [ADP2102-2-EVALZ](#) [ADP2102-3-EVALZ](#) [ADP2102-4-EVALZ](#) [ADP2106-1.8-EVALZ](#) [ADP2147CB-110EVALZ](#) [AS3606-DB](#) [BQ24010EVM](#) [BQ24075TEVM](#) [BQ24155EVM](#) [BQ24157EVM-697](#) [BQ24160EVM-742](#) [BQ24296MEVM-655](#) [BQ25010EVM](#) [BQ3055EVM](#) [NCV891330PD50GEVB](#) [ISLUSBI2CKIT1Z](#) [LM2744EVAL](#) [LM2854EVAL](#) [LM3658SD-AEV/NOPB](#) [LM3658SDEV/NOPB](#) [LM3691TL-1.8EV/NOPB](#) [LM4510SDEV/NOPB](#) [LM5033SD-EVAL](#) [LP38512TS-1.8EV](#) [EVAL-ADM1186-1MBZ](#) [EVAL-ADM1186-2MBZ](#)