

ISL91107IRx-EVZ

Evaluation Boards

UG066
Rev.2.00
Aug 23, 2017

Description

The [ISL91107IR](#) is a high-current buck-boost switching regulator for systems using new battery chemistries. It uses Intersil's proprietary buck-boost algorithm to maintain voltage regulation, while providing excellent efficiency and very low output voltage ripple when the input voltage is close to the output voltage. The ISL91107IRN-EVZ and ISL91107IRA-EVZ platforms allow quick evaluation of the high performance features of the ISL91107IR buck-boost regulator.

Specifications

The boards are designed to operate at the following conditions:

- Input voltage rating from 1.8V to 5.5V
- Resistor programmable output voltage on the ISL91107IRA-EVZ
- Fixed 3.3V output voltage on the ISL91107IRN-EVZ
- Up to 2A output current ($P_{VIN} = 2.8V$, $V_{OUT} = 3.3V$)
- 2.5MHz switching frequency
- Operating temperature range: $-40^{\circ}C$ to $+85^{\circ}C$

Key Board Features

- Small, compact design
- Jumper selectable EN (enabled/disabled)
- Jumper selectable MODE (auto-PFM/forced-PWM)
- Connectors, test points, and jumpers for easy probing

Related Literature

- For a full list of related documents, visit our website - [ISL91107IR](#) product page

Ordering Information

PART NUMBER	DESCRIPTION
ISL91107IRN-EVZ	Evaluation Board for ISL91107IRTNZ
ISL91107IRA-EVZ	Evaluation Board for ISL91107IRTAZ

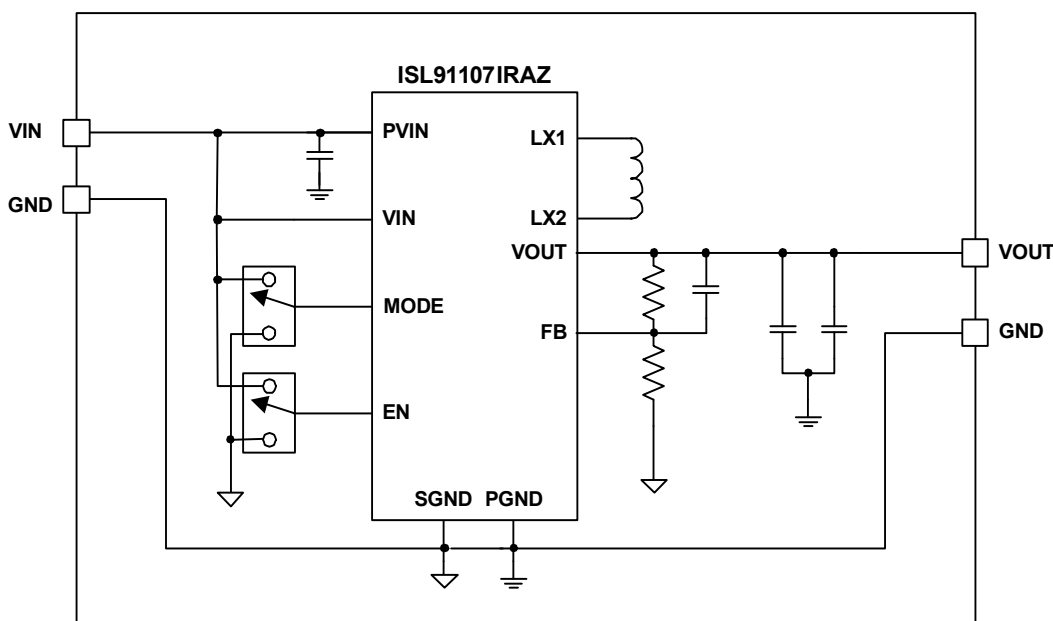

FIGURE 1. ISL91107IRA-EVZ BLOCK DIAGRAM

Functional Description

The ISL91107IRN-EVZ and ISL91107IRA-EVZ provide simple platforms to demonstrate the features of the ISL91107IR buck-boost regulator. The ISL91107IRN-EVZ is for the fixed 3.3V output IC ISL91107IRTNZ. The ISL91107IRA-EVZ is for the adjustable output IC ISL91107IRTAZ. The evaluation boards have been functionally optimized for best performance of the ISL91107IR IC series. The input power and load connections are provided through multi-pin connectors for high current operations.

The ISL91107IRA-EVZ evaluation board is shown in [Figures 4 and 5](#). The board's enable function is controlled by the on-board jumper header J3. Similarly, the Mode function is controlled by the on-board jumper header J4.

The schematic of the ISL91107IRA-EVZ evaluation board is shown in [Figure 6 on page 4](#). The schematic for the ISL91107IRN-EVZ is shown in [Figure 7 on page 5](#). The PCB layout images for all layers are shown in [Figures 8 and 9 on page 6](#). The bill of materials of the ISL91107IRA-EVZ is shown in [Table 2 on page 4](#). The bill of materials of the ISL91107IRN-EVZ is shown in [Table 3 on page 5](#).

Operating Range

The V_{IN} range of the boards is 1.8V to 5.5V. The adjustable V_{OUT} range for the ISL91107IRA-EVZ is 1V to 5.2V. The I_{OUT} range of the boards is 0 to 2A. The operating ambient temperature range is -40°C to $+85^{\circ}\text{C}$.

Quick Start Guide

For the ISL91107IRA-EVZ board, the default output voltage is set at 3.3V. If other output voltages are desired, resistor R_2 can be set to a desired voltage as shown in [Table 1](#) (use a resistor with 1% accuracy).

Refer to the ["Quick Setup Guide"](#) to configure and power up the board for proper operation. During the power-on process, the expected waveforms are shown in [Figures 2 and 3](#).

Quick Setup Guide

1. Install a jumper on J3, shorting EN to VIN.
2. Install a jumper on J4, shorting MODE to VIN.
3. Connect the power supply to J1, with a voltage setting between 1.8V and 5.5V.
4. Connect the electronic load to J2.
5. Place scope probes on the VOUT test point and other test points of interest.
6. Turn on the power supply.
7. Monitor the output voltage start-up sequence on the scope. The waveforms will look similar to that shown in [Figures 2 and 3](#).
8. Turn on the electronic load.
9. Measure the output voltage with the voltmeter. The voltage should regulate within datasheet specific limits.
10. To determine efficiency, measure the input and output voltages at J1 and J2 headers. The bench power supply can be connected to the PVIN and GND headers on J1. The electronic

load can be connected to the VOUT and GND headers on J2. Measure the input and output currents. Calculate efficiency based on these measurements.

TABLE 1. OUTPUT VOLTAGE PROGRAMMING FOR ISL91107IRA-EVZ

DESIRED OUTPUT VOLTAGE (V)	R ₂ RESISTOR VALUE (k Ω)
2.0	124
2.5	88.7
3.0	68.1
3.3	60.4
3.4	57.6
3.6	53.6
4.0	46.4

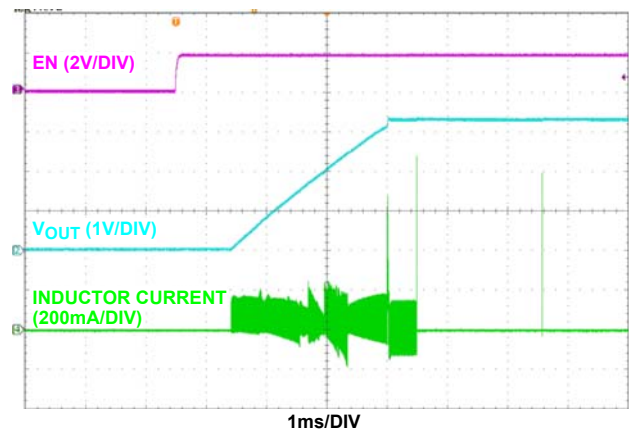

FIGURE 2. ISL91107IR START-UP WITH $V_{IN} = 2\text{V}$ AND $V_{OUT} = 3.3\text{V}$

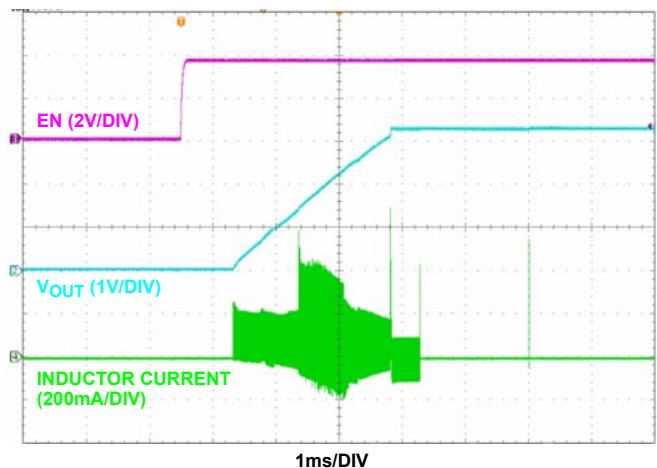

FIGURE 3. ISL91107IR START-UP WITH $V_{IN} = 4\text{V}$ AND $V_{OUT} = 3.3\text{V}$

ISL91107IRA-EVZ and ISL91107IRN-EVZ Evaluation Boards



FIGURE 4. ISL91107IRA-EVZ TOP VIEW



FIGURE 5. ISL91107IRN-EVZ TOP VIEW

ISL91107IRA-EVZ Evaluation Board Schematic

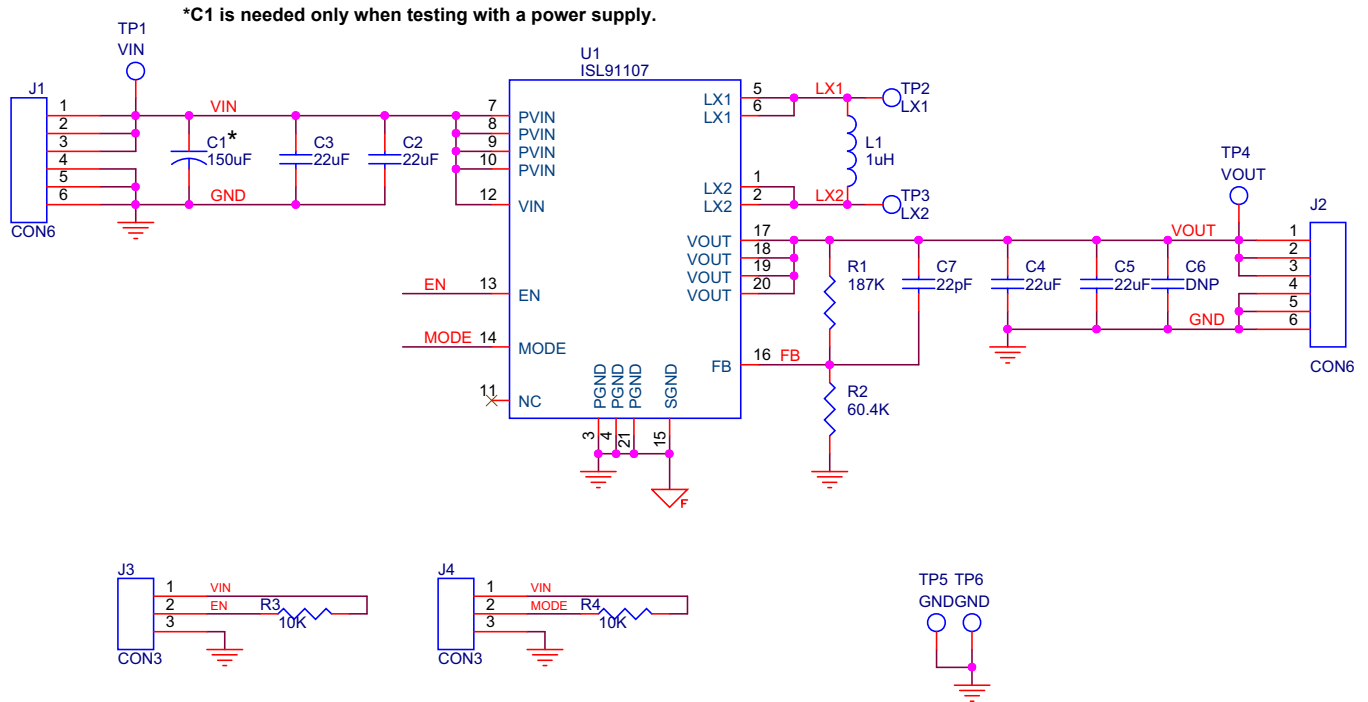

FIGURE 6. ISL91107IRA-EVZ EVALUATION BOARD SCHEMATIC

TABLE 2. ISL91107IRA-EVZ EVALUATION BOARD BILL OF MATERIALS

ITEM#	QTY	DESIGNATORS	PART TYPE	FOOTPRINT	DESCRIPTION	VENDORS
1	1	U1	ISL91107IRTAZ	20 Ld 3x4mm TQFN	Buck-Boost Regulator with Adjustable Output Voltage	Intersil
2	1	L1	1µH	3.2mmx2.5mm	Power Inductor, DFE322512C Series, 4.6A (typical), 34mΩ (typical)	Toko
3	1	C1 (Note 1)	150µF/6.3V	3528	Tantalum Capacitor, TCJH157M006R0200	AVX
4	4	C2, C3, C4, C5	22µF/10V/X5R	0603	Ceramic Capacitor, GRM188R61A226M	Murata
5	1	C7	22pF/50V/NPO	0402	Ceramic Capacitor, GRM1555C1H220JA01D	Murata
6	1	R1	187kΩ, 1%	0402	Resistor, Generic	ANY
7	1	R2	60.4kΩ, 1%	0402	Resistor, Generic	ANY
8	2	R3, R4	10kΩ, 5%	0603	Resistor, Generic	ANY
9	2	J1, J2	HDR-6	HDR-6	Vert. Pin Header, 6-Pin, 0.1" Spacing, Generic	ANY
10	2	J3, J4	HDR-3	HDR-3	Vert. Pin Header, 3-Pin, 0.1" Spacing, Generic	ANY

NOTE:

1. C1 is needed only when testing with a power supply.

ISL91107IRN-EVZ Evaluation Board Schematic

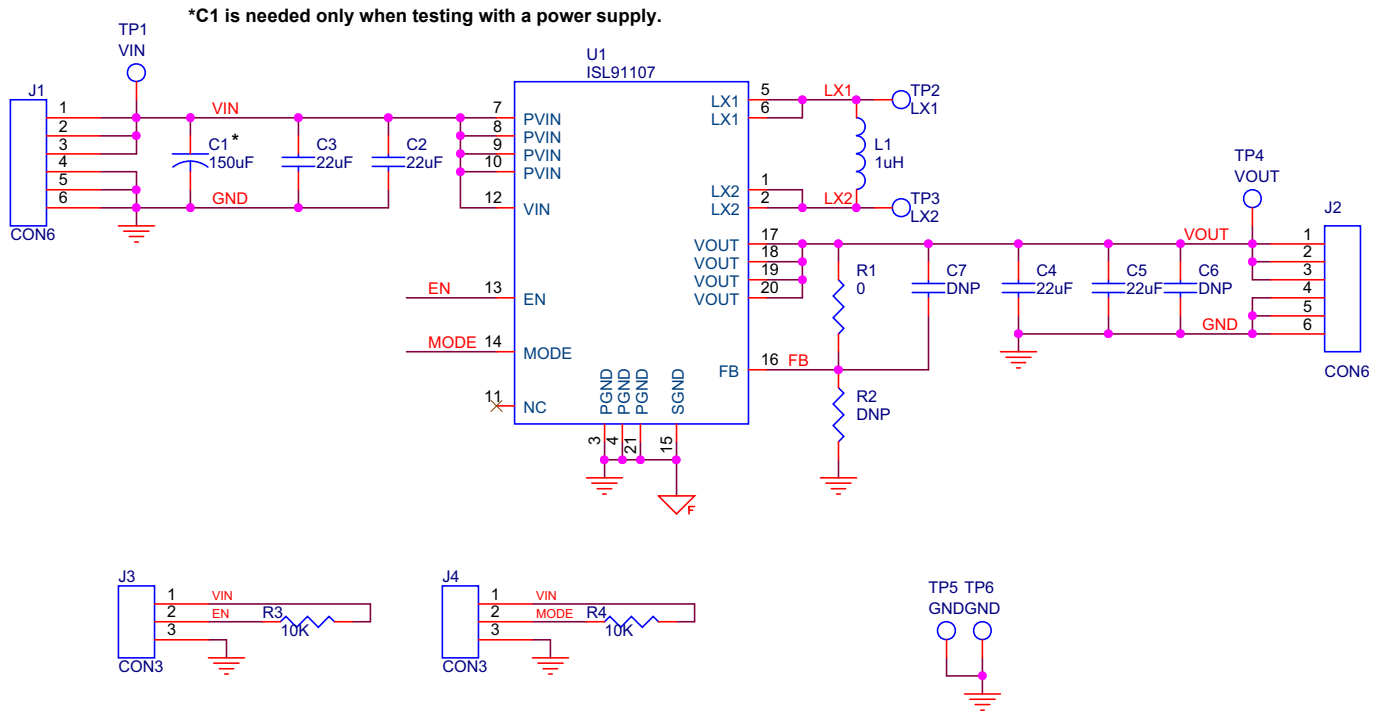

FIGURE 7. ISL91107IRN-EVZ EVALUATION BOARD SCHEMATIC

TABLE 3. ISL91107IRN-EVZ EVALUATION BOARD BILL OF MATERIALS

ITEM#	QTY	DESIGNATORS	PART TYPE	FOOTPRINT	DESCRIPTION	VENDORS
1	1	U1	ISL91107IRTNZ	20 Ld 3x4mm TQFN	Buck-boost regulator with fixed output voltage	Intersil
2	1	L1	1µH	3.2mmx2.5mm	Power inductor, DFE322512C series, 4.6A (typical), 34mΩ (typical)	Toko
3	1	C1 (Note 2)	150µF/6.3V	3528	Tantalum capacitor, TCJH157M006R0200	AVX
4	4	C2, C3, C4, C5	22µF/10V/X5R	0603	Ceramic capacitor, GRM188R61A226M	Murata
5	1	R1	0Ω, 1%	0402	Resistor, Generic	ANY
6	2	R3, R4	10kΩ, 5%	0603	Resistor, Generic	ANY
7	2	J1, J2	HDR-6	HDR-6	Vert. Pin Header, 6-Pin, 0.1" Spacing, Generic	ANY
8	2	J3, J4	HDR-3	HDR-3	Vert. Pin Header, 3-Pin, 0.1" Spacing, Generic	ANY

NOTE:

- C1 is needed only when testing with a power supply.

© Copyright Intersil Americas LLC 2016-2017. All Rights Reserved.
 All trademarks and registered trademarks are the property of their respective owners.

Intersil Corporation reserves the right to make changes in circuit design, software and/or specifications at any time without notice. Accordingly, the reader is cautioned to verify that the document is current before proceeding.

For information regarding Intersil Corporation and its products, see www.intersil.com

PCB Layout

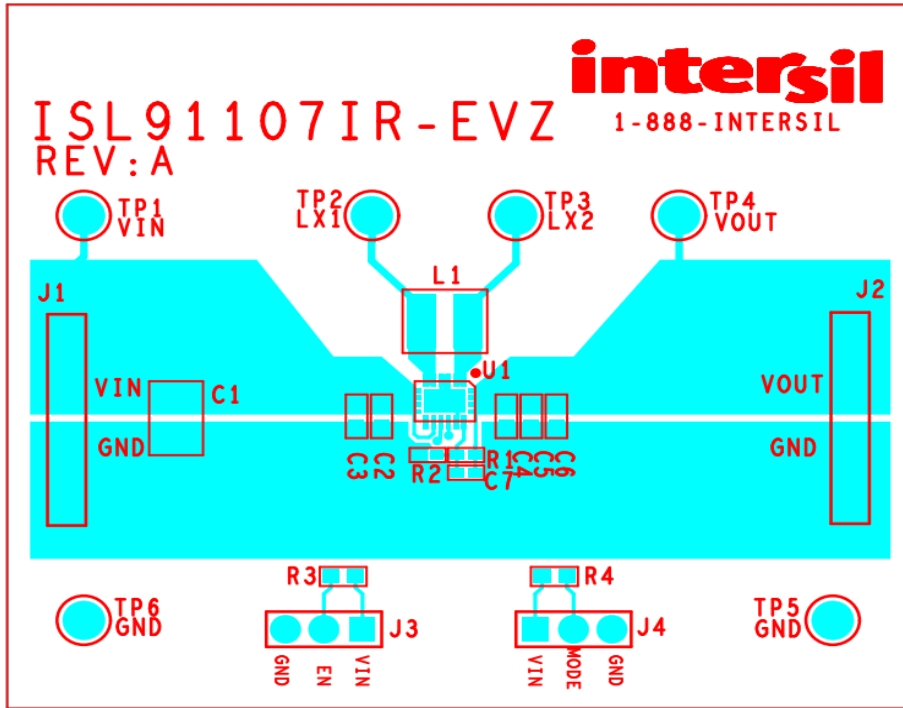

FIGURE 8. TOP LAYER

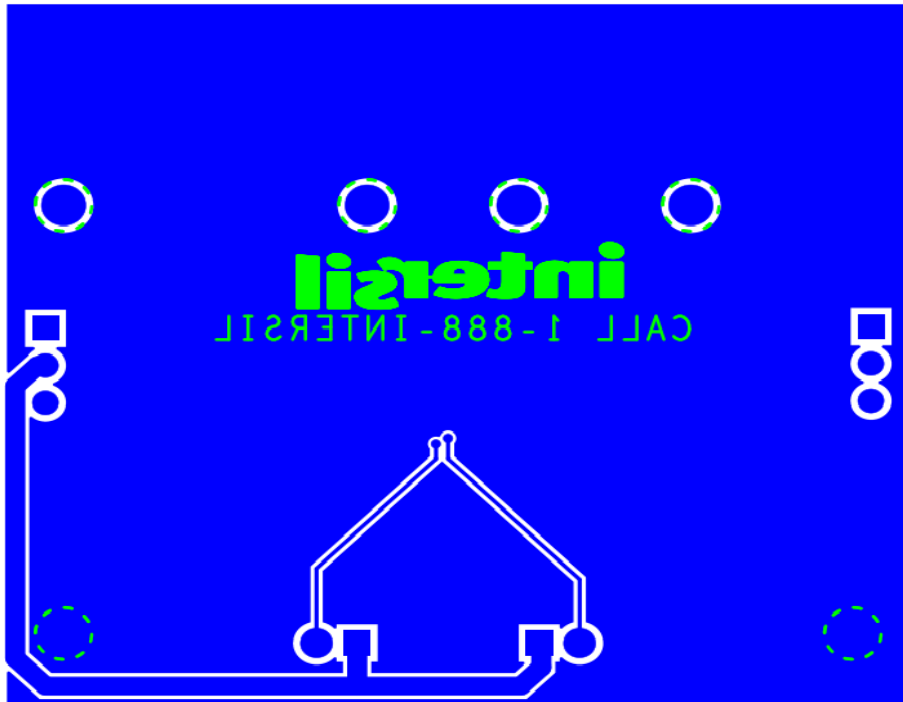

FIGURE 9. BOTTOM LAYER 1

X-ON Electronics

Largest Supplier of Electrical and Electronic Components

Click to view similar products for [Power Management IC Development Tools](#) category:

Click to view products by [Renesas](#) manufacturer:

Other Similar products are found below :

[EVAL-ADM1168LQEBZ](#) [EVB-EP5348UI](#) [MIC23451-AAAYFL EV](#) [MIC5281YMME EV](#) [DA9063-EVAL](#) [ADP122-3.3-EVALZ](#) [ADP130-0.8-EVALZ](#) [ADP130-1.2-EVALZ](#) [ADP130-1.5-EVALZ](#) [ADP130-1.8-EVALZ](#) [ADP1714-3.3-EVALZ](#) [ADP1716-2.5-EVALZ](#) [ADP1740-1.5-EVALZ](#) [ADP1752-1.5-EVALZ](#) [ADP1828LC-EVALZ](#) [ADP1870-0.3-EVALZ](#) [ADP1871-0.6-EVALZ](#) [ADP1873-0.6-EVALZ](#) [ADP1874-0.3-EVALZ](#) [ADP1882-1.0-EVALZ](#) [ADP199CB-EVALZ](#) [ADP2102-1.25-EVALZ](#) [ADP2102-1.875EVALZ](#) [ADP2102-1.8-EVALZ](#) [ADP2102-2-EVALZ](#) [ADP2102-3-EVALZ](#) [ADP2102-4-EVALZ](#) [ADP2106-1.8-EVALZ](#) [ADP2147CB-110EVALZ](#) [AS3606-DB](#) [BQ24010EVM](#) [BQ24075TEVM](#) [BQ24155EVM](#) [BQ24157EVM-697](#) [BQ24160EVM-742](#) [BQ24296MEVM-655](#) [BQ25010EVM](#) [BQ3055EVM](#) [NCV891330PD50GEVB](#) [ISLUSBI2CKIT1Z](#) [LM2744EVAL](#) [LM2854EVAL](#) [LM3658SD-AEV/NOPB](#) [LM3658SDEV/NOPB](#) [LM3691TL-1.8EV/NOPB](#) [LM4510SDEV/NOPB](#) [LM5033SD-EVAL](#) [LP38512TS-1.8EV](#) [EVAL-ADM1186-1MBZ](#) [EVAL-ADM1186-2MBZ](#)