

ISL91133IIX-EVZ

Evaluation Board

AN1958
Rev 0.00
September 5, 2014

Description

The [ISL91133](#) is an integrated boost with bypass switching regulator for battery powered applications. The device provides a power supply solution for products using one cell Li-ion or Li-polymer battery. The device is capable of delivering up to 2.3A output current from $V_{IN} = 2.5V$ and $V_{OUT} = 3.3V$. The no-load quiescent current is only 108µA in Boost mode and 45µA in Forced Bypass mode, which significantly reduces the standby consumption. The ISL91133 evaluation board allows quick evaluation of the high performance features of this regulator.

Specifications

The boards are designed to operate at the following operating conditions:

- Input voltage rating from 2.35V to 5.4V
- Output current: up to 2.3A ($V_{IN} = 2.5V$, $V_{OUT} = 3.3V$)
- Forced bypass or Auto Bypass modes with a 38mΩ switch
- PFM mode at light-load currents
- 108µA quiescent current minimizes standby consumption in Boost mode
- 2.5MHz switching frequency

Key Features

- Jumper selectable EN (Enabled/Disabled)
- Jumper selectable \overline{BYP} S (Auto/Forced)
- Jumper selectable VSET (No offset/offset on V_{OUT})
- Connectors, test points, and jumpers for easy probing

Related Literature

For a full list of related documents, visit our website

- [ISL91133](#) device page

Ordering Information

| EVALUATION BOARD NUMBER | V_{OUT} OPTION |
|-------------------------|----------------------|
| ISL91133IIL-EVZ | 3.15/3.3V (VSET L/H) |
| ISL91133IIM-EVZ | 3.3/3.5V (VSET L/H) |
| ISL91133IIN-EVZ | 3.5/3.7V (VSET L/H) |
| ISL91133IIO-EVZ | 3.7/3.77V (VSET L/H) |
| ISL91133IIP-EVZ | 4.5/4.76V (VSET L/H) |
| ISL91133IIQ-EVZ | 5.0/5.2V (VSET L/H) |

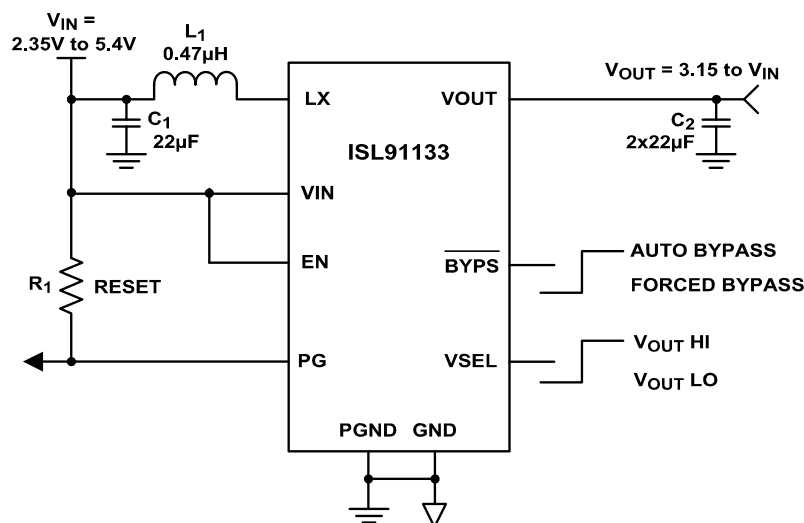

FIGURE 1. ISL91133 TYPICAL APPLICATION SCHEMATIC

Functional Description

The ISL91133 implements a complete boost switching regulator, with PWM controller, internal switches, references, protection circuitry, and bypass control. The ISL91133 is designed to support six fixed output voltage options. A voltage select pin (VSET) is available to scale up the output voltage by a small offset to compensate the load transient droop. The evaluation boards have been functionally optimized for best performance of the ISL91133. This part requires only an inductor and a few external components to operate. The 2.5MHz switching frequency further reduces the size of external components. The input power and load connections are provided through multi-pin connectors for high current operations.

The ISL91133 evaluation board is shown in [Figures 3 and 4](#). The board's enable function is controlled by the on-board jumper header J3. Similarly, the VSET function is controlled by the on-board jumper header J4, and the BYPASS function can be set to Forced or Auto mode by controlling the on-board jumper header J5.

The schematic of the ISL91133IIM-EVZ evaluation board is shown on [page 4](#). The PCB layout images for all layers are shown in [Figures 5 and 6](#). The bill of materials of the ISL91133IIX-EVZ is shown in [Table 1 on page 4](#).

Operating Range

The V_{IN} range of the boards is 2.35V to 5.4V. The V_{OUT} for the ISL91133 can range from 3.15V to 5.2V. The I_{OUT} range of the boards is 0 to 2.3A. The operating ambient temperature range is -40°C to $+85^{\circ}\text{C}$.

Quick Start Guide

For the ISL91133 board, the default output can be selected based on [Table 1](#).

Refer to the following Quick Setup Guide to configure and power-up the board for proper operation. During the power-on process, the expected waveforms are shown in [Figure 2](#).

Quick Setup Guide

1. Install jumpers on J3 shorting EN to VIN.
2. Install jumper on J5 shorting $\overline{\text{BYP}}$ to VIN, Auto Bypass mode.
3. Install jumper on J4 shorting VSET to GND or leave it as NC.
4. Connect power supply to J1, with voltage setting between 2.35V and 5.4V.
5. Connect electronic load to J2.
6. Place scope probes on VOUT test point, and other test points of interest.
7. Turn on the power supply.
8. Monitor the output voltage (refer to ordering information) when $V_{IN} < V_{OUT}$ (Boost mode), $V_{IN} = V_{OUT}$ when $V_{IN} > V_{OUT}$ $1.015 * V_{OUT}$ (Bypass mode), the supply current should be $\sim 110\mu\text{A}$ (Boost mode) and $\sim 95\mu\text{A}$ (Auto Bypass mode). In Forced Bypass mode ($\overline{\text{BYP}}$ pin = GND), supply current should be $\sim 45\mu\text{A}$.
9. Turn on the electronic load.

10. Measure the output voltage with the voltmeter. The voltage should regulate within datasheet specification limits.
11. To determine efficiency, measure input and output voltages at the test points J1 and TP3. The bench power supply can be connected to the PVIN and GND headers on J1. The electronic load can be connected to the V_{OUT} and GND headers on J2. Measure the input and output currents and calculate efficiency based on these measurements.

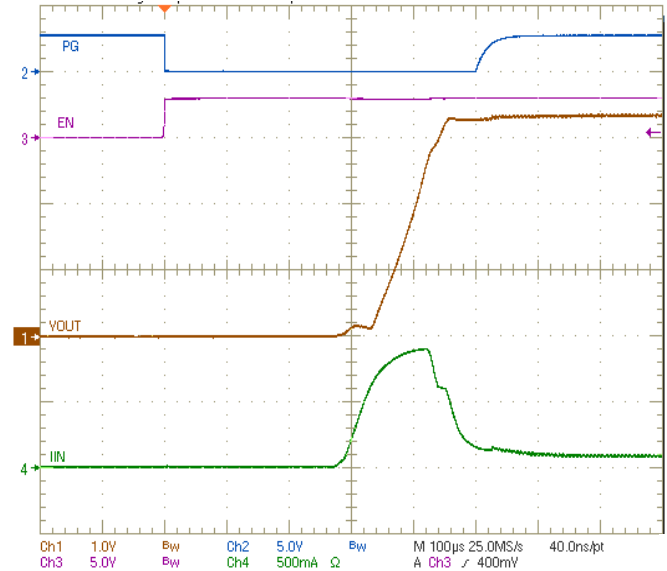

FIGURE 2. START-UP WAVEFORM 50Ω LOAD

Layout Considerations

1. C_1 is used to compensate for line drops on cables from the power supply to the IC, this is not required for the actual board design.
2. Place the input capacitor (C_2) close to the IC to reduce V_{IN} spikes/noise.
3. Place the output capacitors (C_3 , C_4) as close as possible to the IC to minimize V_{OUT} spikes.
4. Connect the boost inductor (L_1) between VIN and LX using short and wide traces. It is recommended to use multiple vias between the LX pin and the inductor. Three vias of 7 mils width were used on the evaluation board.
5. Renesas recommends maximizing the copper pour area for VIN, VOUT, and GND for better thermal performance.
6. Connect AGND and PGND of the IC to each other. It is crucial to connect these two grounds at a location very close to the IC.

ISL91133 Evaluation Board



FIGURE 3. TOP VIEW

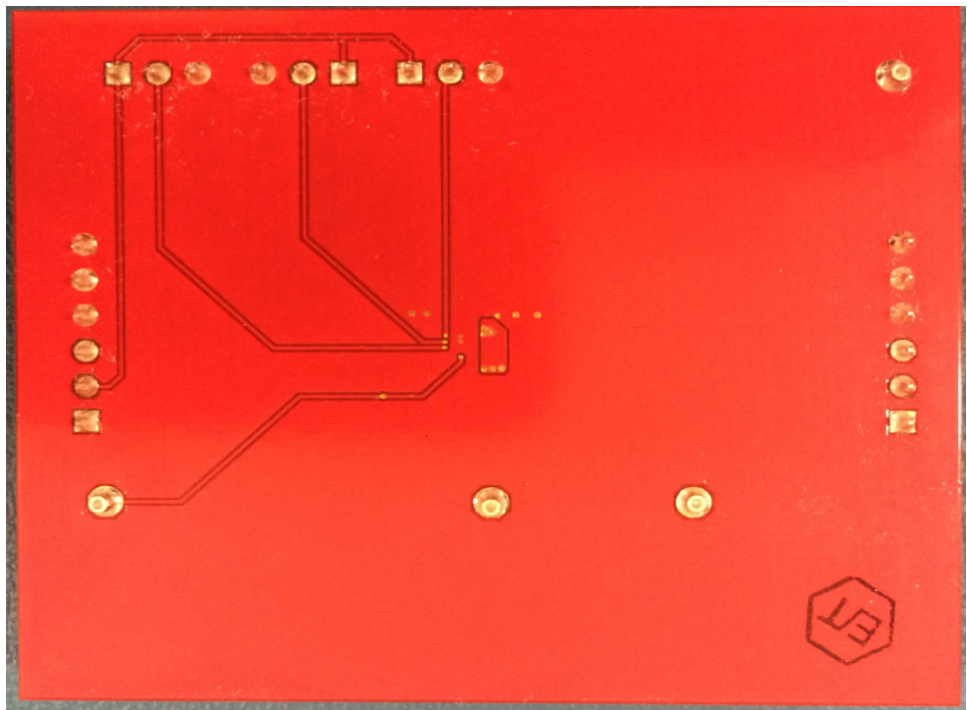

FIGURE 4. BOTTOM VIEW

ISL91133 Evaluation Board Schematic

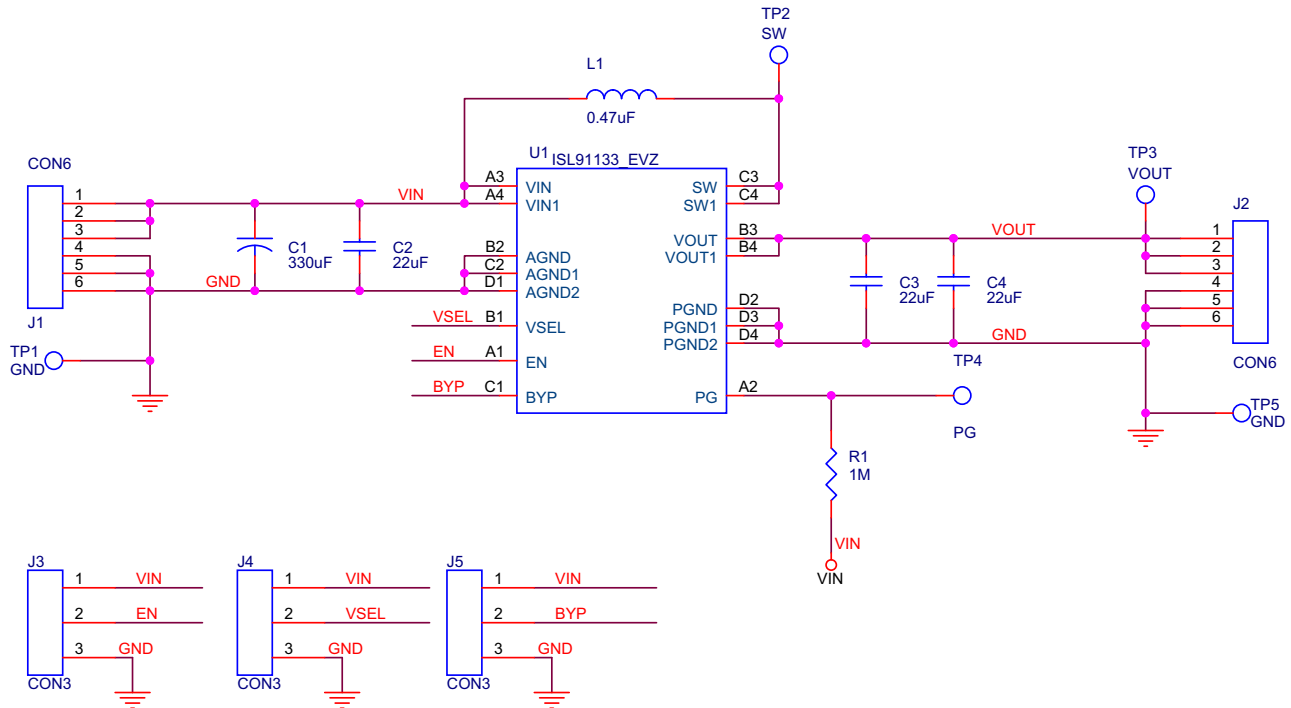

TABLE 1. ISL91133 EVALUATION BOARD BILL OF MATERIALS

| ITEM# | QTY | DESIGNATORS | PART TYPE | FOOTPRINT | DESCRIPTION | VENDORS |
|-------|-----|--------------------|----------------|-------------------|--|----------|
| 1 | 1 | U1 | ISL91133 | W4x4.16E WLCSP | Renesas ISL91133 Boost with Bypass Regulator | Renesas |
| 2 | 1 | L1 | 0.47µH | 3.2x2.5mm | PIFE32251B-R47MS-39 | Cyntec |
| 3 | 1 | C1 | 330µF/6.3V/X5R | 7343 | T491D337K006AT | Kemet |
| 4 | 3 | C2, C3, C4 | 22µF/6.3V/X5R | 0603 | GRM188R61A226M | ANY |
| 5 | 1 | R1 | 1MΩ, 1% | 0603 | Resistor, Generic | ANY |
| 6 | 2 | J1, J2 | HDR-6 | HDR-6 | Vert. Pin Header, 6-Pin, 0.1" Spacing, Generic | FCI |
| 7 | 3 | J3, J4, J5 | HDR-3 | HDR-3 | Vert. Pin Header, 3-Pin, 0.1" Spacing, Generic | FCI |
| 8 | 4 | TP1, TP2, TP3, TP4 | TEST POINT | TEST POINT | Test Point, 1514-2 | KEYSTONE |

PCB Layout

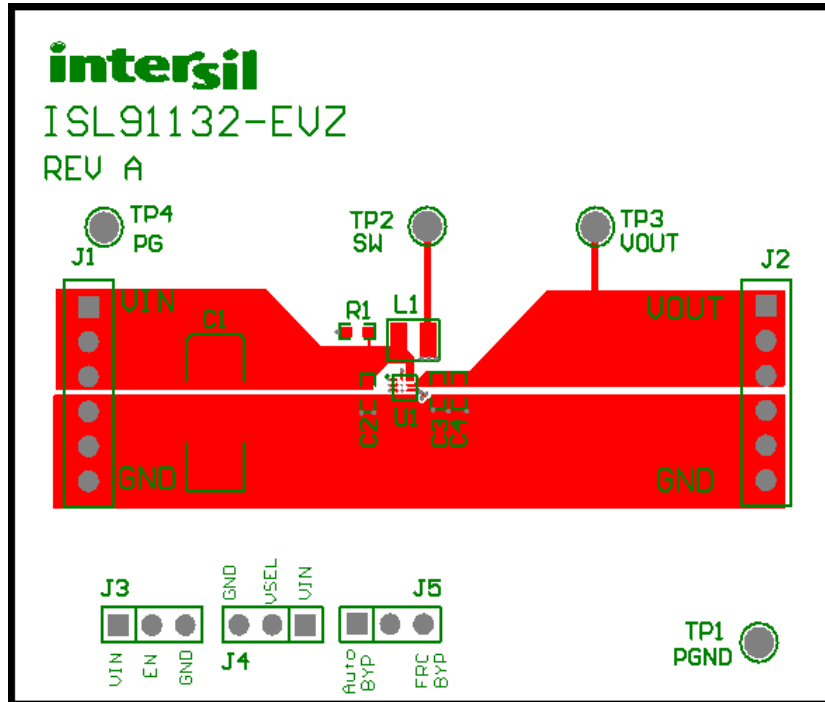

FIGURE 5. TOP LAYER (RECOMMEND USING ISL91132 LAYOUT PLAN FOR ISL91133)

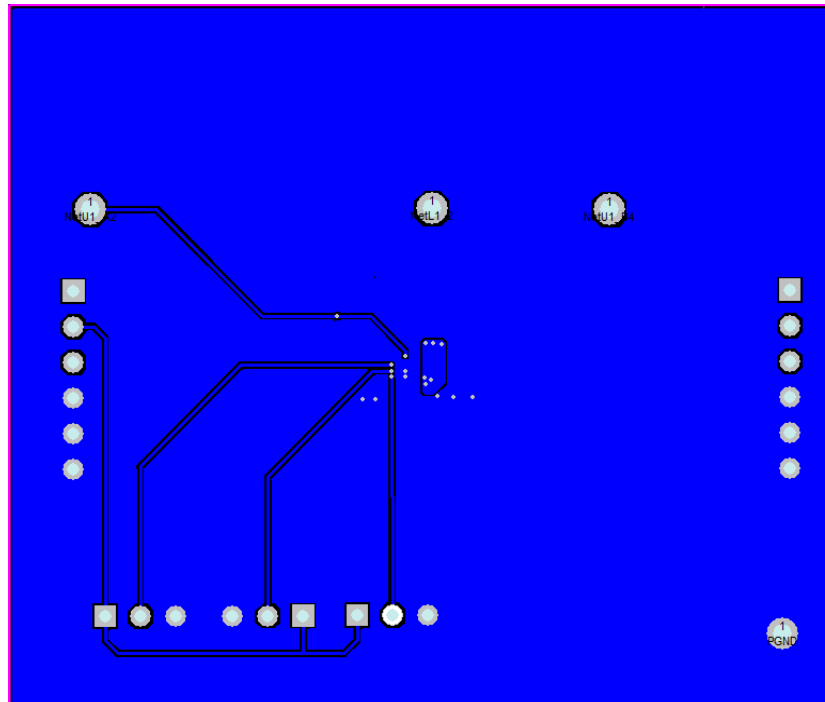

FIGURE 6. BOTTOM LAYER 1

Typical Performance Curves

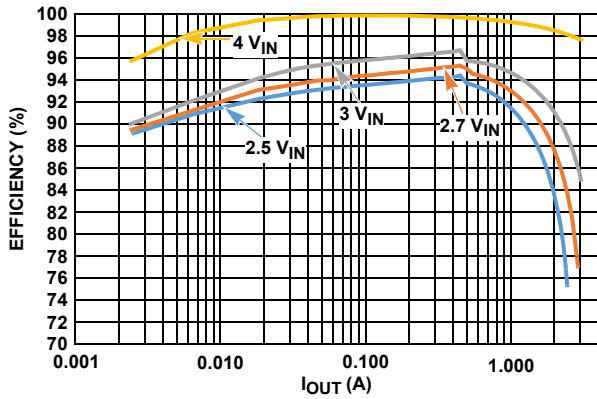

FIGURE 7. EFFICIENCY vs LOAD CURRENT, $V_{OUT} = 3.3V$

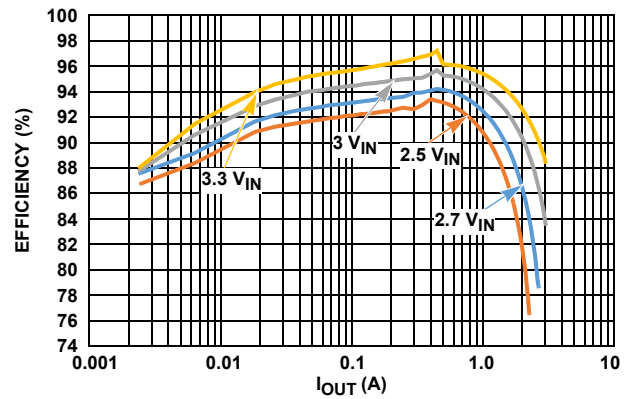

FIGURE 8. EFFICIENCY vs LOAD CURRENT, $V_{OUT} = 3.5V$

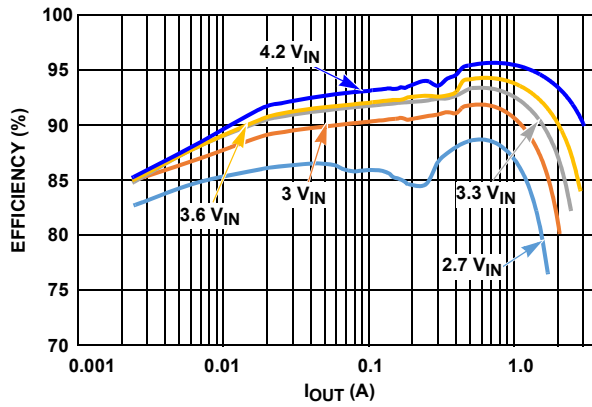

FIGURE 9. EFFICIENCY vs LOAD CURRENT, $V_{OUT} = 5V$

Notice

1. Descriptions of circuits, software and other related information in this document are provided only to illustrate the operation of semiconductor products and application examples. You are fully responsible for the incorporation or any other use of the circuits, software, and information in the design of your product or system. Renesas Electronics disclaims any and all liability for any losses and damages incurred by you or third parties arising from the use of these circuits, software, or information.
 2. Renesas Electronics hereby expressly disclaims any warranties against and liability for infringement or any other claims involving patents, copyrights, or other intellectual property rights of third parties, by or arising from the use of Renesas Electronics products or technical information described in this document, including but not limited to, the product data, drawings, charts, programs, algorithms, and application examples.
 3. No license, express, implied or otherwise, is granted hereby under any patents, copyrights or other intellectual property rights of Renesas Electronics or others.
 4. You shall not alter, modify, copy, or reverse engineer any Renesas Electronics product, whether in whole or in part. Renesas Electronics disclaims any and all liability for any losses or damages incurred by you or third parties arising from such alteration, modification, copying or reverse engineering.
 5. Renesas Electronics products are classified according to the following two quality grades: "Standard" and "High Quality". The intended applications for each Renesas Electronics product depends on the product's quality grade, as indicated below.
 - "Standard": Computers; office equipment; communications equipment; test and measurement equipment; audio and visual equipment; home electronic appliances; machine tools; personal electronic equipment; industrial robots; etc.
 - "High Quality": Transportation equipment (automobiles, trains, ships, etc.); traffic control (traffic lights); large-scale communication equipment; key financial terminal systems; safety control equipment; etc.Unless expressly designated as a high reliability product or a product for harsh environments in a Renesas Electronics data sheet or other Renesas Electronics document, Renesas Electronics products are not intended or authorized for use in products or systems that may pose a direct threat to human life or bodily injury (artificial life support devices or systems; surgical implantations; etc.), or may cause serious property damage (space system; undersea repeaters; nuclear power control systems; aircraft control systems; key plant systems; military equipment; etc.). Renesas Electronics disclaims any and all liability for any damages or losses incurred by you or any third parties arising from the use of any Renesas Electronics product that is inconsistent with any Renesas Electronics data sheet, user's manual or other Renesas Electronics document.
 6. When using Renesas Electronics products, refer to the latest product information (data sheets, user's manuals, application notes, "General Notes for Handling and Using Semiconductor Devices" in the reliability handbook, etc.), and ensure that usage conditions are within the ranges specified by Renesas Electronics with respect to maximum ratings, operating power supply voltage range, heat dissipation characteristics, installation, etc. Renesas Electronics disclaims any and all liability for any malfunctions, failure or accident arising out of the use of Renesas Electronics products outside of such specified ranges.
 7. Although Renesas Electronics endeavors to improve the quality and reliability of Renesas Electronics products, semiconductor products have specific characteristics, such as the occurrence of failure at a certain rate and malfunctions under certain use conditions. Unless designated as a high reliability product or a product for harsh environments in a Renesas Electronics data sheet or other Renesas Electronics document, Renesas Electronics products are not subject to radiation resistance design. You are responsible for implementing safety measures to guard against the possibility of bodily injury, injury or damage caused by fire, and/or danger to the public in the event of a failure or malfunction of Renesas Electronics products, such as safety design for hardware and software, including but not limited to redundancy, fire control and malfunction prevention, appropriate treatment for aging degradation or any other appropriate measures. Because the evaluation of microcomputer software alone is very difficult and impractical, you are responsible for evaluating the safety of the final products or systems manufactured by you.
 8. Please contact a Renesas Electronics sales office for details as to environmental matters such as the environmental compatibility of each Renesas Electronics product. You are responsible for carefully and sufficiently investigating applicable laws and regulations that regulate the inclusion or use of controlled substances, including without limitation, the EU RoHS Directive, and using Renesas Electronics products in compliance with all these applicable laws and regulations. Renesas Electronics disclaims any and all liability for damages or losses occurring as a result of your noncompliance with applicable laws and regulations.
 9. Renesas Electronics products and technologies shall not be used for or incorporated into any products or systems whose manufacture, use, or sale is prohibited under any applicable domestic or foreign laws or regulations. You shall comply with any applicable export control laws and regulations promulgated and administered by the governments of any countries asserting jurisdiction over the parties or transactions.
 10. It is the responsibility of the buyer or distributor of Renesas Electronics products, or any other party who distributes, disposes of, or otherwise sells or transfers the product to a third party, to notify such third party in advance of the contents and conditions set forth in this document.
 11. This document shall not be reprinted, reproduced or duplicated in any form, in whole or in part, without prior written consent of Renesas Electronics.
 12. Please contact a Renesas Electronics sales office if you have any questions regarding the information contained in this document or Renesas Electronics products.
- (Note1) "Renesas Electronics" as used in this document means Renesas Electronics Corporation and also includes its directly or indirectly controlled subsidiaries.
- (Note2) "Renesas Electronics product(s)" means any product developed or manufactured by or for Renesas Electronics.

(Rev.4.0-1 November 2017)

Corporate Headquarters

TOYOSU FORESIA, 3-2-24 Toyosu,
Koto-ku, Tokyo 135-0061, Japan
www.renesas.com

Trademarks

Renesas and the Renesas logo are trademarks of Renesas Electronics Corporation. All trademarks and registered trademarks are the property of their respective owners.

Contact Information

For further information on a product, technology, the most up-to-date version of a document, or your nearest sales office, please visit:
www.renesas.com/contact/

X-ON Electronics

Largest Supplier of Electrical and Electronic Components

Click to view similar products for [Power Management IC Development Tools](#) category:

Click to view products by [Renesas](#) manufacturer:

Other Similar products are found below :

[EVAL-ADM1168LQEBZ](#) [EVB-EP5348UI](#) [MIC23451-AAAYFL EV](#) [MIC5281YMME EV](#) [DA9063-EVAL](#) [ADP122-3.3-EVALZ](#) [ADP130-0.8-EVALZ](#) [ADP130-1.2-EVALZ](#) [ADP130-1.5-EVALZ](#) [ADP130-1.8-EVALZ](#) [ADP1714-3.3-EVALZ](#) [ADP1716-2.5-EVALZ](#) [ADP1740-1.5-EVALZ](#) [ADP1752-1.5-EVALZ](#) [ADP1828LC-EVALZ](#) [ADP1870-0.3-EVALZ](#) [ADP1871-0.6-EVALZ](#) [ADP1873-0.6-EVALZ](#) [ADP1874-0.3-EVALZ](#) [ADP1882-1.0-EVALZ](#) [ADP199CB-EVALZ](#) [ADP2102-1.25-EVALZ](#) [ADP2102-1.875EVALZ](#) [ADP2102-1.8-EVALZ](#) [ADP2102-2-EVALZ](#) [ADP2102-3-EVALZ](#) [ADP2102-4-EVALZ](#) [ADP2106-1.8-EVALZ](#) [ADP2147CB-110EVALZ](#) [AS3606-DB](#) [BQ24010EVM](#) [BQ24075TEVM](#) [BQ24155EVM](#) [BQ24157EVM-697](#) [BQ24160EVM-742](#) [BQ24296MEVM-655](#) [BQ25010EVM](#) [BQ3055EVM](#) [NCV891330PD50GEVB](#) [ISLUSBI2CKIT1Z](#) [LM2744EVAL](#) [LM2854EVAL](#) [LM3658SD-AEV/NOPB](#) [LM3658SDEV/NOPB](#) [LM3691TL-1.8EV/NOPB](#) [LM4510SDEV/NOPB](#) [LM5033SD-EVAL](#) [LP38512TS-1.8EV](#) [EVAL-ADM1186-1MBZ](#) [EVAL-ADM1186-2MBZ](#)