

## Description

The MK2302-01 is a high performance Zero Delay Buffer (ZDB) which integrates IDT's proprietary analog/digital Phase Locked Loop (PLL) techniques. The chip is part of IDT's ClockBlocks™ family and was designed as a performance upgrade to meet today's higher speed and lower voltage requirements. The zero delay feature means that the rising edge of the input clock aligns with the rising edges of both output clocks, giving the appearance of no delay through the device. There are two outputs on the chip, one being a low-skew divide by two of the other output.

The MK2302-01 is ideal for synchronizing outputs in a large variety of systems, from personal computers to data communications to graphics/video. By allowing off-chip feedback paths, the device can eliminate the delay through other devices.

## Features

- 8-pin SOIC package
- Pb (lead) free package
- Low input to output skew of 250 ps max
- Absolute jitter  $\pm 500$  ps
- Propagation Delay  $\pm 350$  ps
- Ability to choose between different multipliers from 0.5X to 16X
- Output clock frequency up to 168 MHz at 3.3 V
- Can recover degraded input clock duty cycle
- Output clock duty cycle of 45/55
- Full CMOS clock swings with 25mA drive capability at TTL levels
- Advanced, low power CMOS process
- Operating voltage of 3.3 V or 5 V
- Industrial temperature version available

## Block Diagram

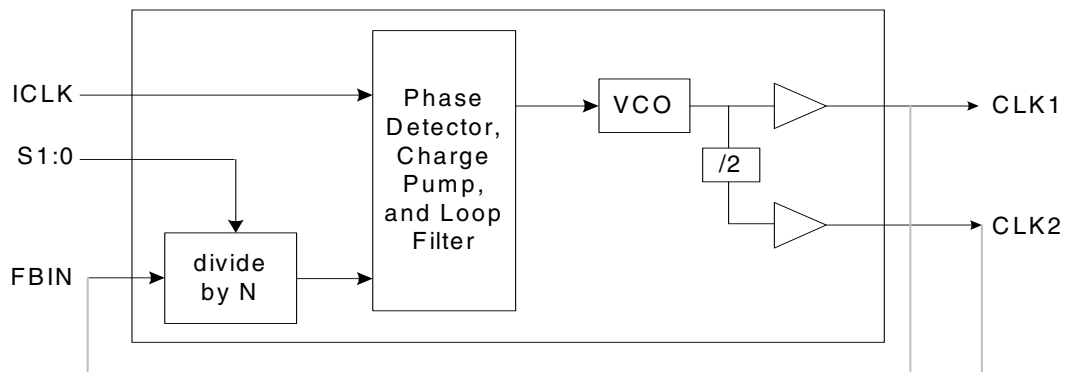

External feedback can come from CLK1 or CLK2 (see table on page 2)

## Pin Assignment

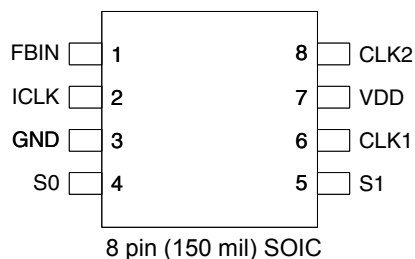

## Clock Multiplier Decoding Table 1

(Multiplies Input clock by shown amount)

FBIN	S1	S0	CLK1	CLK2
CLK1	0	0	2 X ICLK	ICLK
CLK1	0	1	4 X ICLK	2 X ICLK
CLK1	1	0	ICLK	ICLK/2
CLK1	1	1	8 X ICLK	4 X ICLK
CLK2	0	0	4 X ICLK	2 X ICLK
CLK2	0	1	8 X ICLK	4 X ICLK
CLK2	1	0	2 X ICLK	ICLK
CLK2	1	1	16 X ICLK	8 X ICLK

## Pin Descriptions

Pin Number	Pin Name	Pin Type	Pin Description
1	FBIN	Input	Feedback clock input.
2	ICLK	Input	Reference clock input.
3	GND	Power	Connect to ground.
4	S0	Input	Select 0 for output clock per decoding table above. Pull-up.
5	S1	Input	Select 1 for output clock per decoding table above. Pull up.
6	CLK1	Output	Clock output per table above.
7	VDD	Power	Connect to +3.3 V or +5.0 V.
8	CLK2	Output	Clock output per table above. Low skew divide by two of pin 6 clock.

## External Components

The MK2302-01 requires a 0.01 $\mu$ F decoupling capacitor to be connected between VDD and GND. It must be connected close to the part to minimize lead inductance. No external power supply filtering is required for this device. A 33 $\Omega$  series terminating resistor can be used next to each output pin.

Using CLK1 as the feedback will always result in synchronized rising edges between ICLK and CLK1. However, the CLK2 could be a falling edge compared with ICLK. IDT recommends using CLK2 feedback whenever possible. This will synchronize the rising edges of all three clocks.

## Absolute Maximum Ratings

Stresses above the ratings listed below can cause permanent damage to the MK2302-01. These ratings, which are standard values for IDT commercially rated parts, are stress ratings only. Functional operation of the device at these or any other conditions above those indicated in the operational sections of the specifications is not implied. Exposure to absolute maximum rating conditions for extended periods can affect product reliability. Electrical parameters are guaranteed only over the recommended operating temperature range.

Item	Rating
Supply Voltage, VDD	7 V
All Inputs and Outputs	-0.5 V to VDD+0.5 V
Ambient Operating Temperature	-55 to 125° C
Storage Temperature	-65 to +150° C
Junction Temperature	125° C
Power Dissipation	0.5 W

## Recommended Operation Conditions

Parameter	Min.	Typ.	Max.	Units
Ambient Operating Temperature (commercial)	0		+70	°C
Ambient Operating Temperature (industrial)	-40		+85	°C
Power Supply Voltage (measured in respect to GND)	+4.5	+5.0	+5.5	V
Power Supply Voltage (measured in respect to GND)	+3.15	+3.3	+3.45	V

## DC Electrical Characteristics

VDD = 3.3 V ±5%, Ambient Temperature 0 to +70°C or -40°C to 85°C

Parameter	Symbol	Conditions	Min.	Typ.	Max.	Units
Operating Voltage	VDD		3.15		3.45	V
Operating Current	IDD			20		ma
Input High Voltage	V <sub>IH</sub>	ICLK, FBIN	2			V
Input Low Voltage	V <sub>IL</sub>	ICLK, FBIN			0.8	V
Input High Voltage	V <sub>IH</sub>	S0, S1	VDD-0.5			V
Input Low Voltage (mid-level)	V <sub>IM</sub>	S0, S1		VDD/2		V
Input Low Voltage	V <sub>IL</sub>	S0, S1			0.5	V
Output High Voltage (CMOS High)	V <sub>OH</sub>	I <sub>OH</sub> = -4 mA	VDD-0.4			V
Output High Voltage	V <sub>OH</sub>	I <sub>OH</sub> = -12 mA	2.4			V
Output Low Voltage	V <sub>OL</sub>	I <sub>OL</sub> = 12 mA			0.4	V
Short Circuit Current	I <sub>OS</sub>	Each output		±70		mA
Input Capacitance	C <sub>IN</sub>	S0, S1		5		pF

VDD = 5 V ±10%, Ambient Temperature 0 to +70°C or -40°C to 85°C

Parameter	Symbol	Conditions	Min.	Typ.	Max.	Units
Operating Voltage	VDD	5V	4.5		5.5	V
Operating Current	IDD			30		ma
Input High Voltage	V <sub>IH</sub>	ICLK, FBIN	2			V
Input Low Voltage	V <sub>IL</sub>	ICLK, FBIN			0.8	V
Input High Voltage	V <sub>IH</sub>	S0, S1	VDD-0.5			V
Input Low Voltage (mid-level)	V <sub>IM</sub>	S0, S1		VDD/2		V
Input Low Voltage	V <sub>IL</sub>	S0, S1			0.5	V
Output High Voltage (CMOS High)	V <sub>OH</sub>	I <sub>OH</sub> = -4 mA	VDD-0.4			V
Output High Voltage	V <sub>OH</sub>	I <sub>OH</sub> = -12 mA	2.4			V
Output Low Voltage	V <sub>OL</sub>	I <sub>OL</sub> = 12 mA			0.4	V
Short Circuit Current	I <sub>OS</sub>	Each output		±100		mA
Input Capacitance	C <sub>IN</sub>	S0, S1		5		pF

## AC Electrical Characteristics

VDD = 3.3 V or 5 V  $\pm$ 5%, Ambient Temperature 0 to +70° C or -40° C to 85° C

Parameter	Symbol	Conditions	Min.	Typ.	Max.	Units
Input Frequency, ICLK		FBIN from CLK/2	See table on page 2			
Output Clock Frequency		CLK1	10		168	MHz
Output to Output Skew				100	175	ps
Input to Output Jitter		40 - 150 MHz			200	ps
Input Skew		ICLK to FBIN, CLK>30 MHz, Note 1	-300		300	ps
		ICLK to FBIN, CLK<30 MHz, Note 1	-600		600	ps
Output Clock Rise Time		0.8 to 2.0 V, Note 2		0.8	1	ns
Output Clock Fall Time		2.0 to 0.8 V, Note 2		0.8	1	ns
Output Clock Duty Cycle		at VDD/2	40	49 - 51	60	%

Note 1: Assumes clocks with same rise time, measured from rising edges at VDD/2.

Note 2: Measured with 27 $\Omega$  terminating resistor and 15 pF loads.

## Thermal Characteristics

Parameter	Symbol	Conditions	Min.	Typ.	Max.	Units
Thermal Resistance Junction to Ambient	$\theta_{JA}$	Still air		150		°C/W
	$\theta_{JA}$	1 m/s air flow		140		°C/W
	$\theta_{JA}$	3 m/s air flow		120		°C/W
Thermal Resistance Junction to Case	$\theta_{JC}$			40		°C/W

## Package Outline and Package Dimensions (8-pin SOIC, 150 Mil. Body)

Package dimensions are kept current with JEDEC Publication No. 95

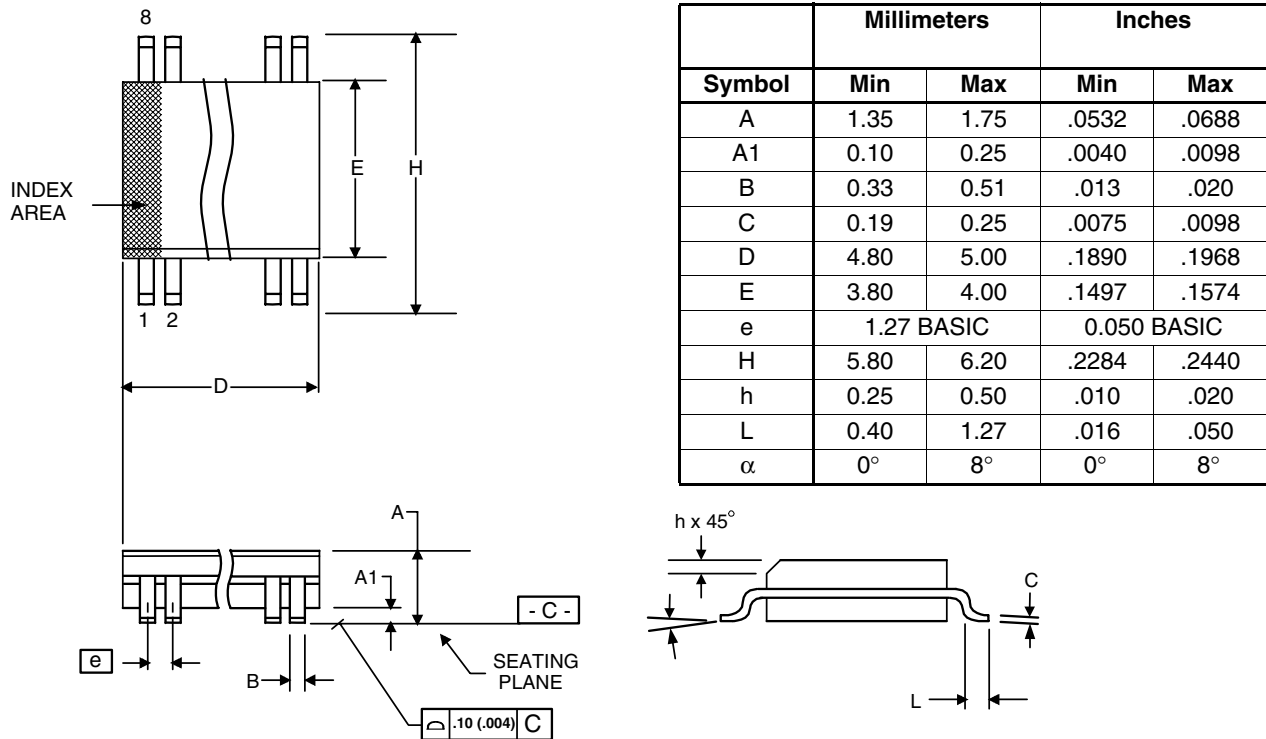

## Ordering Information

Part / Order Number	Marking	Shipping Pkg	Package	Temperature
MK2302S-01LF	230201LF	Tubes	8-pin SOIC	0 to +70° C
MK2302S-01LFT	230201LF	Tape and Reel	8-pin SOIC	0 to +70° C
MK2302S-01ILF	230201ILF	Tubes	8-pin SOIC	-40 to 85° C
MK2302S-01ILFT	230201ILF	Tape and Reel	8-pin SOIC	-40 to 85° C

"LF" suffix to the part number are the Pb-Free configuration and are RoHS compliant.

While the information presented herein has been checked for both accuracy and reliability, Integrated Device Technology (IDT) assumes no responsibility for either its use or for the infringement of any patents or other rights of third parties, which would result from its use. No other circuits, patents, or licenses are implied. This product is intended for use in normal commercial applications. Any other applications such as those requiring extended temperature range, high reliability, or other extraordinary environmental requirements are not recommended without additional processing by IDT. IDT reserves the right to change any circuitry or specifications without notice. IDT does not authorize or warrant any IDT product for use in life support devices or critical medical instruments.



## IMPORTANT NOTICE AND DISCLAIMER

RENESAS ELECTRONICS CORPORATION AND ITS SUBSIDIARIES (“RENESAS”) PROVIDES TECHNICAL SPECIFICATIONS AND RELIABILITY DATA (INCLUDING DATASHEETS), DESIGN RESOURCES (INCLUDING REFERENCE DESIGNS), APPLICATION OR OTHER DESIGN ADVICE, WEB TOOLS, SAFETY INFORMATION, AND OTHER RESOURCES “AS IS” AND WITH ALL FAULTS, AND DISCLAIMS ALL WARRANTIES, EXPRESS OR IMPLIED, INCLUDING, WITHOUT LIMITATION, ANY IMPLIED WARRANTIES OF MERCHANTABILITY, FITNESS FOR A PARTICULAR PURPOSE, OR NON-INFRINGEMENT OF THIRD PARTY INTELLECTUAL PROPERTY RIGHTS.

These resources are intended for developers skilled in the art designing with Renesas products. You are solely responsible for (1) selecting the appropriate products for your application, (2) designing, validating, and testing your application, and (3) ensuring your application meets applicable standards, and any other safety, security, or other requirements. These resources are subject to change without notice. Renesas grants you permission to use these resources only for development of an application that uses Renesas products. Other reproduction or use of these resources is strictly prohibited. No license is granted to any other Renesas intellectual property or to any third party intellectual property. Renesas disclaims responsibility for, and you will fully indemnify Renesas and its representatives against, any claims, damages, costs, losses, or liabilities arising out of your use of these resources. Renesas' products are provided only subject to Renesas' Terms and Conditions of Sale or other applicable terms agreed to in writing. No use of any Renesas resources expands or otherwise alters any applicable warranties or warranty disclaimers for these products.

(Rev.1.0 Mar 2020)

### Corporate Headquarters

TOYOSU FORESIA, 3-2-24 Toyosu,  
Koto-ku, Tokyo 135-0061, Japan  
[www.renesas.com](http://www.renesas.com)

### Contact Information

For further information on a product, technology, the most up-to-date version of a document, or your nearest sales office, please visit:  
[www.renesas.com/contact/](http://www.renesas.com/contact/)

### Trademarks

Renesas and the Renesas logo are trademarks of Renesas Electronics Corporation. All trademarks and registered trademarks are the property of their respective owners.



## X-ON Electronics

Largest Supplier of Electrical and Electronic Components

*Click to view similar products for [Clock Buffer](#) category:*

*Click to view products by [Renesas](#) manufacturer:*

Other Similar products are found below :

[MPC962309EJ-1H](#) [NB4N121KMNG](#) [IDT49FCT805ASO](#) [MK2308S-1HILF](#) [PL133-27GI-R](#) [NB3L02FCT2G](#) [NB3L03FCT2G](#)  
[ZL40203LDG1](#) [ZL40200LDG1](#) [ZL40205LDG1](#) [9FG1200DF-1LF](#) [9FG1001BGLF](#) [ZL40202LDG1](#) [PI49FCT20802QE](#) [SL2305SC-1T](#)  
[PI6C4931502-04LIE](#) [NB7L1008MNG](#) [NB7L14MN1G](#) [PI49FCT20807QE](#) [PI6C4931502-04LIEX](#) [ZL80002QAB1](#) [PI6C4931504-04LIEX](#)  
[PI6C10806BLEX](#) [ZL40226LDG1](#) [ZL40219LDG1](#) [8T73S208B-01NLGI](#) [SY75578LMG](#) [PI49FCT32805QEX](#) [PL133-27GC-R](#)  
[CDCV304PWG4](#) [MC10LVEP11DG](#) [MC10EP11DTG](#) [MC100LVEP11DG](#) [MC100E111FNG](#) [MC100EP11DTG](#) [NB6N11SMNG](#)  
[NB7L14MMNG](#) [NB3N2304NZDTR2G](#) [NB6L11MMNG](#) [NB6L14MMNR2G](#) [NB6L611MNG](#) [PL123-02NGI-R](#) [NB3N111KMNR4G](#)  
[ADCLK944BCPZ-R7](#) [ZL40217LDG1](#) [NB7LQ572MNG](#) [HMC940LC4BTR](#) [ADCLK946BCPZ-REEL7](#) [ADCLK946BCPZ](#)  
[ADCLK846BCPZ-REEL7](#)