

3.3 VOLT ZERO DELAY, LOW SKEW BUFFER

MK2308-1H

Description

The MK2308-1H is a low phase noise, high-speed PLL based, 8-output, low skew zero delay buffer. Based on ICS' proprietary low jitter Phase Locked Loop (PLL) techniques, the device provides eight low skew outputs at speeds up to 133 MHz at 3.3 V. The outputs can be generated from the PLL (for zero delay), or directly from the input (for testing), and can be set to tri-state mode or to stop at a low level. For normal operation as a zero delay buffer, any output clock is tied to the FBIN pin.

ICS manufactures a large variety of clock generators and buffers.

Features

- Clock outputs from 10 to 133 MHz
- Zero input-output delay
- Eight low skew (<200 ps) outputs
- Device-to-device skew <700 ps
- Full CMOS outputs with 25 mA output drive capability at TTL levels
- 5 V tolerant FBIN and CLKIN pins
- Tri-state mode for board-level testing
- Advanced, low-power, sub-micron CMOS process
- Operating voltage of 3.3 V
- Industrial temperature range available
- Packaged in 16-pin SOIC and TSSOP packages
- Available in Pb (lead) free package
- Industrial and commercial temp operation

Block Diagram

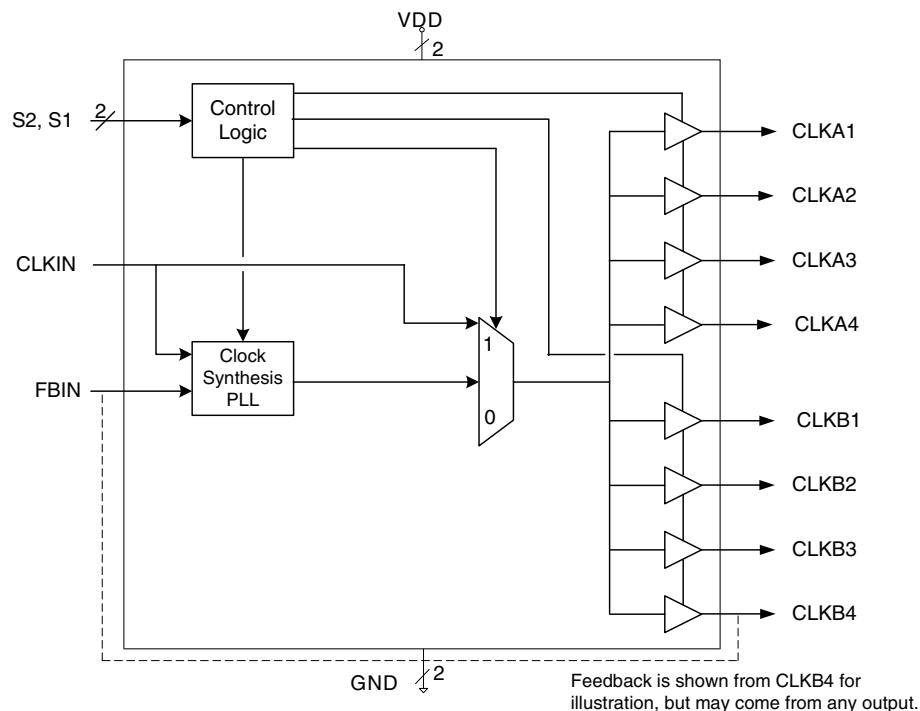

Pin Assignment

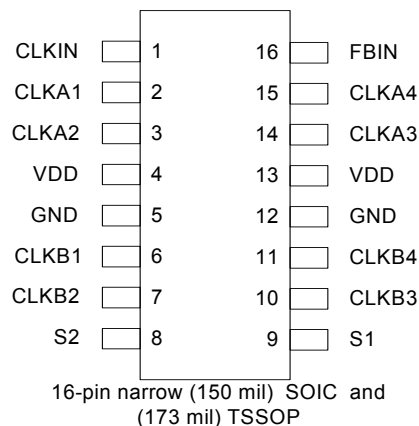

Output Clock Mode Select Table

S2	S1	CLKA1:A4	CLKB1:B4	A & B Source	PLL Status
0	0	Tri-state (note 1)	Tri-state (note 1)	PLL	OFF
0	1	Running	Tri-state (note 1)	PLL	ON
1	0	Running	Running	CLKIN (note 2)	OFF
1	1	Running	Running	PLL	ON

Note 1. Outputs are in high impedance state

Note 2. Buffer mode only; not zero delay between input and output

Pin Descriptions

Pin Number	Pin Name	Pin Type	Pin Description
1	CLKIN	Input	Clock input (5 V tolerant).
2 - 3	CLKA1:A4	Output	Clock outputs A1:A4. See table above.
4	VDD	Power	Power supply. Connect to 3.3 V.
5	GND	Power	Connect to ground.
6 - 7	CLKB1:B4	Output	Clock outputs B1:B4. See table above.
8	S2	Input	Select input 2. See table above. Internal pull-up.
9	S1	Input	Select input 1. See table above. Internal pull-up.
10 - 11	CLKB1:B4	Output	Clock outputs B1:B4. See table above.
12	GND	Power	Connect to ground.
13	VDD	Power	Power supply. Connect to 3.3 V.
14 - 15	CLKA1:A4	Output	Clock outputs A1:A4. See table above.
16	FBIN	Input	Feedback input. Connect to any output under normal operation (5 V tolerant).

External Components

The MK2308-1H requires a minimum number of external components for proper operation. Decoupling capacitors of 0.01 mF should be connected between VDD and GND on pins 4 and 5, and VDD and GND on pins 13 and 12, as close to the device as possible. A series termination resistor of 33Ω may be used to each clock output pin to reduce reflections.

Absolute Maximum Ratings

Stresses above the ratings listed below can cause permanent damage to the MK2308-1H. These ratings, which are standard values for ICS commercially rated parts, are stress ratings only. Functional operation of the device at these or any other conditions above those indicated in the operational sections of the specifications is not implied. Exposure to absolute maximum rating conditions for extended periods can affect product reliability. Electrical parameters are guaranteed only over the recommended operating temperature range.

Item	Rating
Supply Voltage, VDD	7 V
All Inputs and Outputs	-0.5 V to VDD+0.5 V
CLKIN and FBIN inputs	-0.5 V to 5.5 V
Electrostatic Discharge	2000 V
Ambient Operating Temperature	0 to +70°C
Industrial Temperature	-40 to +85°C
Storage Temperature	-65 to +150°C
Junction Temperature	150°C
Soldering Temperature	260°C

Recommended Operation Conditions

Parameter	Min.	Typ.	Max.	Units
Ambient Operating Temperature	-40		+85	°C
Power Supply Voltage (measured in respect to GND)	+3.0		+3.6	V

DC Electrical Characteristics

VDD=3.3 V ±10%, Ambient temperature -40 to +85°C (Industrial), 0 to 70°C (Commercial)

Parameter	Symbol	Conditions	Min.	Typ.	Max.	Units
Operating Voltage	VDD		3.0		3.6	V
Input High Voltage	V _{IH}		2			V
Input Low Voltage	V _{IL}				0.8	V
Input Low Current	I _{IL}	V _{IN} = 0V			50	μA
Input High Current	I _{IH}	V _{IN} = VDD			100	μA
Output High Voltage	V _{OH}	I _{OH} = -12 mA	2.4			V
Output Low Voltage	V _{OL}	I _{OL} = 12 mA			0.4	V

Parameter	Symbol	Conditions	Min.	Typ.	Max.	Units
Output High Voltage, CMOS level	V_{OH}	$I_{OH} = -4 \text{ mA}$	VDD-0.4			V
Operating Supply Current	IDD	No Load, S2 = 1, S1 = 1, Note 1			70	mA
Power Down Supply Current	IDDPD	CLKIN = 0, S2 = 0, S1 = 1		12		μA
		CLKIN = 0, Note 2		12		μA
Short Circuit Current	I_{OS}	Each output		± 70		mA
Input Capacitance	C_{IN}	S2, S1, FBIN		5		pF

AC Electrical Characteristics

VDD = 3.3 V $\pm 10\%$, Ambient Temperature -40 to +85°C (Industrial), 0 to 70°C (Commercial)

Parameter	Symbol	Conditions	Min.	Typ.	Max.	Units
Input Clock Frequency	f_{IN}	See table on page 2	10		133	MHz
Output Clock Frequency		See table on page 2	10		133	MHz
Output Rise Time	t_{OR}	0.8 to 2.0V, CL=30pF			1.5	ns
Output Fall Time	t_{OF}	2.0 to 0.8V, CL=30pF			1.25	ns
Output Clock Duty Cycle	t_{DC}	measured at VDD/2	45	50	55	%
Device to Device Skew		rising edges at VDD/2			700	ps
Output to Output Skew		rising edges at VDD/2			200	ps
Input to Output Skew		rising edges at VDD/2, FBIN to CLKA4, S1 = 1, S0 = 1, Note 1			± 250	ps
Maximum Absolute Jitter		CL=15 pF, measured at 66.67M		130		ps
Cycle to Cycle Jitter		CL=30 pF, measured at 66.67M			200	ps
		CL=15 pF, measured at 66.67M			200	ps
		CL=15 pF, measured at 133.33M			100	ps
PLL Lock Time		Note 3			1.0	ms

Note 1: With CLKIN = 100 MHz, FBIN to CLKA4, all outputs at 100 MHz

Note 2: When there is no clock signal present at CLKIN, the MK2308-1H will enter power down mode. The PLL is stopped and the outputs are tri-state.

Note 3: With VDD at a steady rate and valid clocks at CLKIN and FBIN

Thermal Characteristics 16TSSOP

Parameter	Symbol	Conditions	Min.	Typ.	Max.	Units
Thermal Resistance Junction to Ambient	θ_{JA}	Still air		78		$^{\circ}\text{C/W}$
	θ_{JA}	1 m/s air flow		70		$^{\circ}\text{C/W}$
	θ_{JA}	3 m/s air flow		68		$^{\circ}\text{C/W}$
Thermal Resistance Junction to Case	θ_{JC}			37		$^{\circ}\text{C/W}$

Thermal Characteristics 16SOIC

Parameter	Symbol	Conditions	Min.	Typ.	Max.	Units
Thermal Resistance Junction to Ambient	θ_{JA}	Still air		120		$^{\circ}\text{C}/\text{W}$
	θ_{JA}	1 m/s air flow		115		$^{\circ}\text{C}/\text{W}$
	θ_{JA}	3 m/s air flow		105		$^{\circ}\text{C}/\text{W}$
Thermal Resistance Junction to Case	θ_{JC}			58		$^{\circ}\text{C}/\text{W}$

Package Outline and Package Dimensions (16-pin SOIC, 150 Mil. Narrow Body)

Package dimensions are kept current with JEDEC Publication No. 95

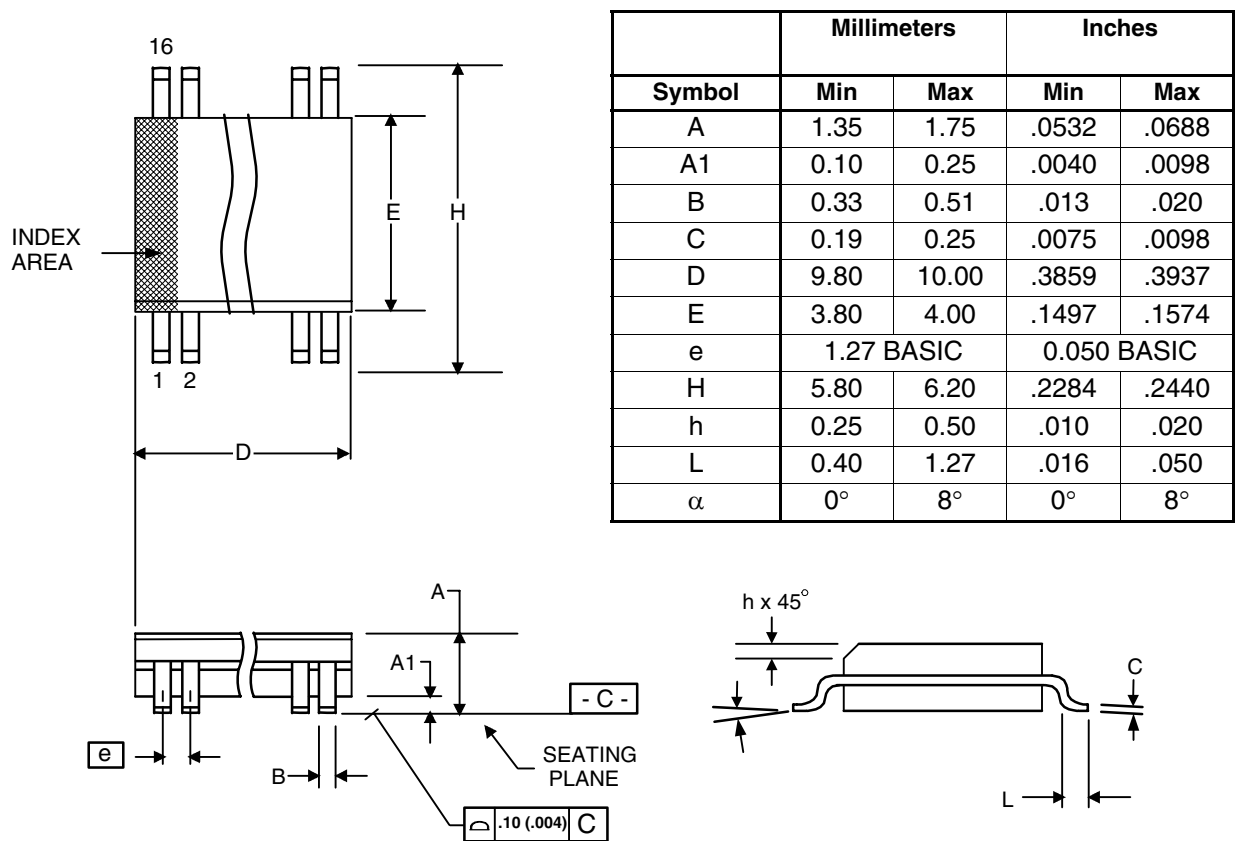

Package Outline and Package Dimensions (16-pin TSSOP, 4.40 mm Body, 0.65 mm Pitch)

Package dimensions are kept current with JEDEC Publication No. 95

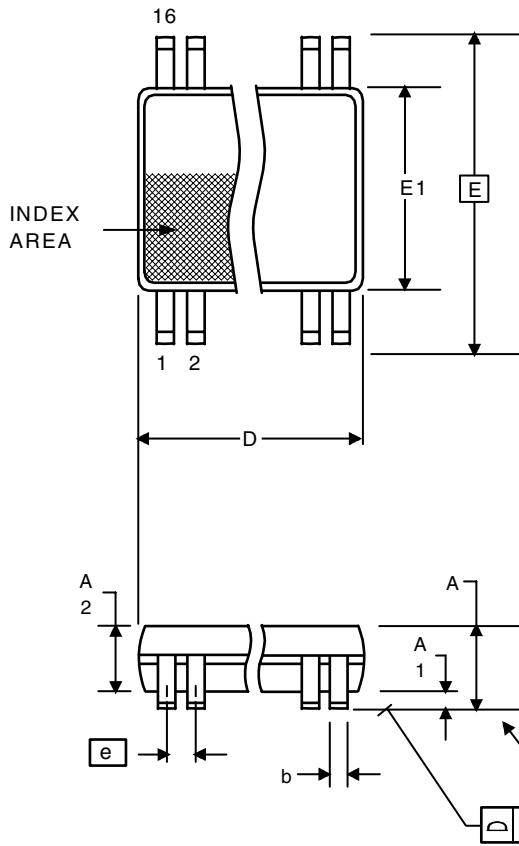

Symbol	Millimeters		Inches	
	Min	Max	Min	Max
A	--	1.20	--	0.047
A1	0.05	0.15	0.002	0.006
A2	0.80	1.05	0.032	0.041
b	0.19	0.30	0.007	0.012
C	0.09	0.20	0.0035	0.008
D	4.90	5.1	0.193	0.201
E	6.40 BASIC		0.252 BASIC	
E1	4.30	4.50	0.169	0.177
e	0.65 Basic		0.0256 Basic	
L	0.45	0.75	0.018	0.030
α	0°	8°	0°	8°
aaa	--	0.10	--	0.004

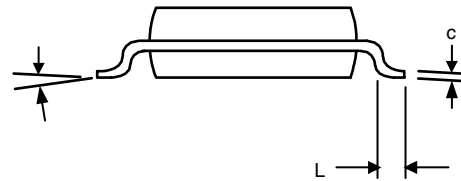

Ordering Information

Part / Order Number	Marking	Shipping Packaging	Package	Temperature
MK2308S-1H	MK2308S-1H	Tubes	16-pin SOIC	0 to +70° C
MK2308S-1HTR	MK2308S-1H	Tape and Reel	16-pin SOIC	0 to +70° C
MK2308S-1HLF	MK2308S-1HLF	Tubes	16-pin SOIC	0 to +70° C
MK2308S-1HLFTR	MK2308S-1HLF	Tape and Reel	16-pin SOIC	0 to +70° C
MK2308S-1HI	MK2308S-1HI	Tubes	16-pin SOIC	-40 to +85° C
MK2308S-1HITR	MK2308S-1HI	Tape and Reel	16-pin SOIC	-40 to +85° C
MK2308G-1HI	2308-1HI	Tubes	16-pin TSSOP	-40 to +85° C
MK2308G-1HITR	2308-1HI	Tape and Reel	16-pin TSSOP	-40 to +85° C
MK2308G-1HILF	23081HIL	Tubes	16-pin TSSOP	-40 to +85° C
MK2308G-1HILFTR	23081HIL	Tape and Reel	16-pin TSSOP	-40 to +85° C
MK2308G-1H	2308G-1H	Tubes	16-pin TSSOP	0 to +70° C
MK2308G-1HTR	2308G-1H	Tape and Reel	16-pin TSSOP	0 to +70° C
MK2308G-1HLF	2308-1HL	Tubes	16-pin TSSOP	0 to +70° C
MK2308G-1HLFTR	2308-1HL	Tape and Reel	16-pin TSSOP	0 to +70° C

Parts that are ordered with a "LF" suffix to the part number are the Pb-Free configuration and are RoHS compliant.

While the information presented herein has been checked for both accuracy and reliability, Integrated Circuit Systems (ICS) assumes no responsibility for either its use or for the infringement of any patents or other rights of third parties, which would result from its use. No other circuits, patents, or licenses are implied. This product is intended for use in normal commercial applications. Any other applications such as those requiring extended temperature range, high reliability, or other extraordinary environmental requirements are not recommended without additional processing by ICS. ICS reserves the right to change any circuitry or specifications without notice. ICS does not authorize or warrant any ICS product for use in life support devices or critical medical instruments.

Innovate with IDT and accelerate your future networks. Contact:

www.IDT.com

For Sales

800-345-7015
408-284-8200
Fax: 408-284-2775

For Tech Support

<product line email>
<product line phone>

Corporate Headquarters

Integrated Device Technology, Inc.
6024 Silver Creek Valley Road
San Jose, CA 95138
United States
800 345 7015
+408 284 8200 (outside U.S.)

Asia Pacific and Japan

Integrated Device Technology
Singapore (1997) Pte. Ltd.
Reg. No. 199707558G
435 Orchard Road
#20-03 Wisma Atria
Singapore 238877
+65 6 887 5505

Europe

IDT Europe, Limited
Prime House
Barnett Wood Lane
Leatherhead, Surrey
United Kingdom KT22 7DE
+44 1372 363 339



X-ON Electronics

Largest Supplier of Electrical and Electronic Components

Click to view similar products for [Clock Buffer](#) category:

Click to view products by [Renesas](#) manufacturer:

Other Similar products are found below :

[MPC962309EJ-1H](#) [NB4N121KMNG](#) [IDT49FCT805ASO](#) [MK2308S-1HILF](#) [PL133-27GI-R](#) [NB3L02FCT2G](#) [NB3L03FCT2G](#)
[ZL40203LDG1](#) [ZL40200LDG1](#) [ZL40205LDG1](#) [9FG1200DF-1LF](#) [9FG1001BGLF](#) [ZL40202LDG1](#) [PI49FCT20802QE](#) [SL2305SC-1T](#)
[PI6C4931502-04LIE](#) [NB7L1008MNG](#) [NB7L14MN1G](#) [PI49FCT20807QE](#) [PI6C4931502-04LIEX](#) [ZL80002QAB1](#) [PI6C4931504-04LIEX](#)
[PI6C10806BLEX](#) [ZL40226LDG1](#) [ZL40219LDG1](#) [8T73S208B-01NLGI](#) [SY75578LMG](#) [PI49FCT32805QEX](#) [PL133-27GC-R](#)
[CDCV304PWG4](#) [MC10LVEP11DG](#) [MC10EP11DTG](#) [MC100LVEP11DG](#) [MC100E111FNG](#) [MC100EP11DTG](#) [NB6N11SMNG](#)
[NB7L14MMNG](#) [NB6L11MMNG](#) [NB6L14MMNR2G](#) [NB6L611MNG](#) [PL123-02NGI-R](#) [NB3N111KMNR4G](#) [ADCLK944BCPZ-R7](#)
[ZL40217LDG1](#) [NB7LQ572MNG](#) [HMC940LC4BTR](#) [ADCLK946BCPZ-REEL7](#) [ADCLK946BCPZ](#) [ADCLK846BCPZ-REEL7](#)
[ADCLK854BCPZ-REEL7](#)