

**FEATURES:**

- Enhanced N channel FET with no inherent diode to Vcc
- Very low ON resistance (5Ω typical)
- Zero propagation delay, zero added ground bounce
- Fast turn-on/turn-off time
- Undershoot clamp diodes on all switch and control inputs
- Available in SOIC package

**APPLICATIONS:**

- Line control
- Hot-swapping, hot-docking
- Voltage translation (5V to 3.3V)
- Power conservation
- Capacitance reduction and isolation
- Clock gating
- Bus isolation
- Signal suppression/blinking

**DESCRIPTION:**

The QS3306A provides a set of two high-speed low resistance (3Ω typical) CMOS switches connecting inputs to outputs without propagation delay and without generating additional ground bounce noise. Individual enables ( $\overline{OE}$ ) are used to turn on the switches. The QS3306A is ideal for signal and control switching since the device adds no noise, ground bounce, propagation delay, or significant power consumption to the system. The QS3306A can also be used for analog switching applications such as video. The QS3306A is characterized for operation at -40°C to +85°C.

**FUNCTIONAL BLOCK DIAGRAM**

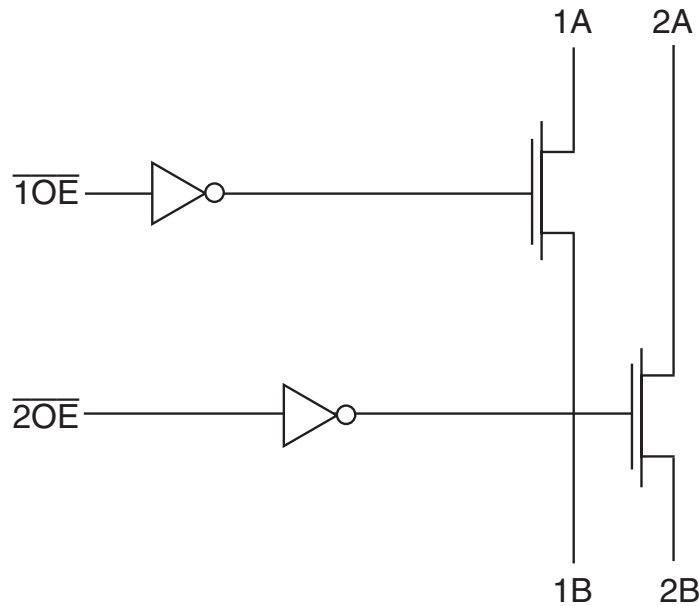

## PIN CONFIGURATION

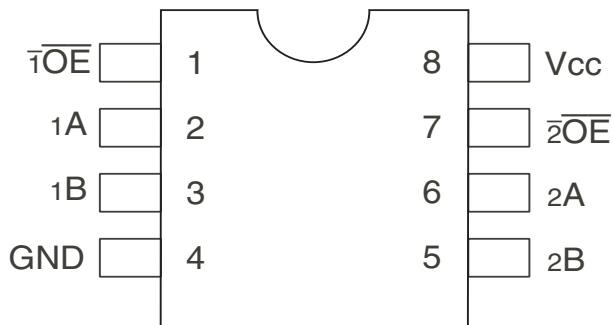

SOIC (S1)  
TOP VIEW

## ABSOLUTE MAXIMUM RATINGS<sup>(1)</sup>

Symbol	Description	Max	Unit
VTERM <sup>(2)</sup>	Supply Voltage to Ground	-0.5 to +7	V
VTERM <sup>(3)</sup>	DC Switch Voltage Vs	-0.5 to +7	V
VTERM <sup>(3)</sup>	DC Input Voltage VIN	-0.5 to +7	V
VAC	AC Input Voltage (pulse width ≤20ns)	-3	V
IOUT	DC Output Current	120	mA
PMAX	Maximum Power Dissipation	0.5	W
TSTG	Storage Temperature	-65 to +150	°C

### NOTES:

- Stresses greater than those listed under ABSOLUTE MAXIMUM RATINGS may cause permanent damage to the device. This is a stress rating only and functional operation of the device at these or any other conditions above those indicated in the operational sections of this specification is not implied. Exposure to absolute maximum rating conditions for extended periods may affect reliability.
- Vcc terminals.
- All terminals except Vcc .

## CAPACITANCE (TA = +25°C, f = 1MHz, VIN = 0V, VOUT = 0V)

Pins	Typ.	Max. <sup>(1)</sup>	Unit
$\overline{OE}$ (Inputs)	3	5	pF
Quickswitch Channels (Switch OFF)	5	7	pF

### NOTE:

- This parameter is guaranteed but not production tested.

## PIN DESCRIPTION

Pin Names	I/O	Description
1A - 2A	I/O	Bus A
1B - 2B	I/O	Bus B
$\overline{1OE}$ - $\overline{2OE}$	I	Switch Enable

## FUNCTION TABLE<sup>(1)</sup>

$\overline{xOE}$	xA	xB	Function
L	H	H	Connect
L	L	L	Connect
H	X	X	Disconnect

### NOTE:

- H = HIGH Voltage Level  
L = LOW Voltage Level  
X = Don't Care

## DC ELECTRICAL CHARACTERISTICS OVER OPERATING RANGE

Following Conditions Apply Unless Otherwise Specified:

Industrial:  $T_A = -40^{\circ}\text{C}$  to  $+85^{\circ}\text{C}$ ,  $V_{CC} = 5\text{V} \pm 5\%$

Symbol	Parameter	Test Conditions	Min.	Typ. <sup>(1)</sup>	Max.	Unit
$V_{IH}$	Input HIGH Voltage	Guaranteed Logic HIGH for Control Pins	2	—	—	V
$V_{IL}$	Input LOW Voltage	Guaranteed Logic LOW for Control Pins	—	—	0.8	V
$I_{IN}$	Input Leakage Current (Control Inputs)	$0\text{V} \leq V_{IN} \leq V_{CC}$	—	—	$\pm 1$	$\mu\text{A}$
$I_{OZ}$	Off-State Current (Hi-Z)	$0\text{V} \leq V_{OUT} \leq V_{CC}$ , Switches OFF	—	—	$\pm 1$	$\mu\text{A}$
RON	Switch ON Resistance <sup>(2)</sup>	$V_{CC} = \text{Min.}, V_{IN} = 0\text{V}, I_{ON} = 30\text{mA}$	—	5	7	$\Omega$
		$V_{CC} = \text{Min.}, V_{IN} = 2.4\text{V}, I_{ON} = 15\text{mA}$	—	10	15	
VP	Pass Voltage <sup>(3)</sup>	$V_{IN} = V_{CC} = 5\text{V}, I_{OUT} = -5\mu\text{A}$	3.7	4	4.2	V

**NOTES:**

1. Typical values are at  $V_{CC} = 5\text{V}$  and  $T_A = 25^{\circ}\text{C}$ .
2.  $R_{ON}$  is guaranteed but not production tested.
3. Pass voltage is guaranteed but not production tested.

### TYPICAL ON RESISTANCE vs VIN AT VCC = 5V

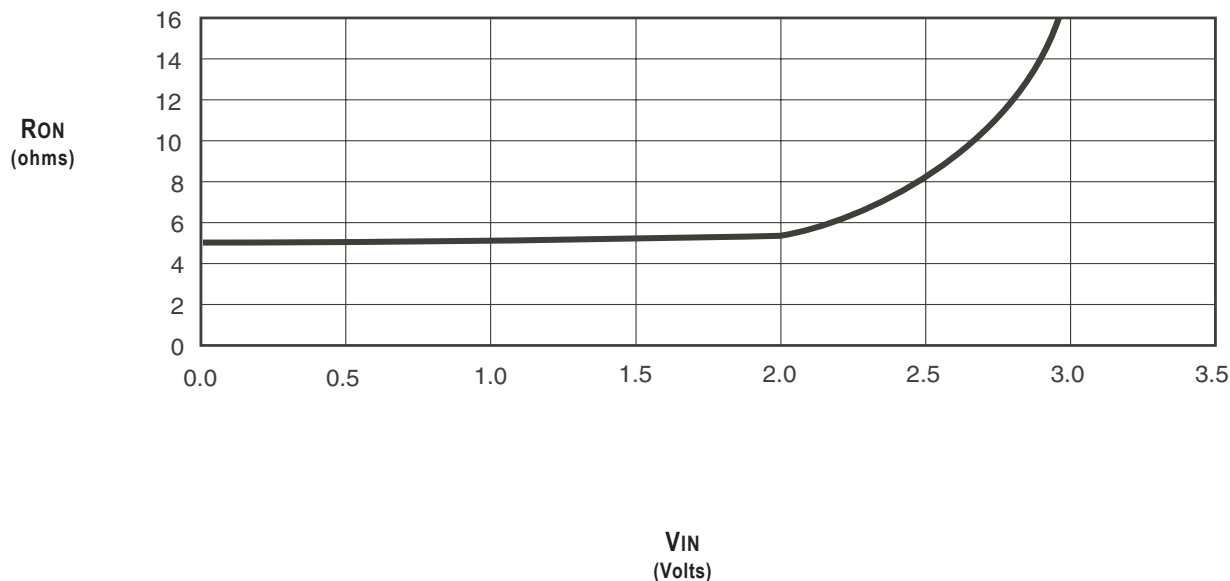

## POWER SUPPLY CHARACTERISTICS

Symbol	Parameter	Test Conditions <sup>(1)</sup>	Max.	Unit
I <sub>CCQ</sub>	Quiescent Power Supply Current	V <sub>CC</sub> = Max., V <sub>IN</sub> = GND or V <sub>CC</sub> , f = 0	3	μA
ΔI <sub>CC</sub>	Power Supply Current per Input HIGH <sup>(2)</sup>	V <sub>CC</sub> = Max., V <sub>IN</sub> = 3.4V, f = 0	1	mA
I <sub>CCD</sub>	Dynamic Power Supply Current per MHz <sup>(3)</sup>	V <sub>CC</sub> = Max., A and B Pins Open, Control Inputs Toggling @ 50% Duty Cycle	0.25	mA/MHz

### NOTES:

- For conditions shown as Min. or Max., use the appropriate values specified under DC Electrical Characteristics.
- Per TTL-driven input (V<sub>IN</sub> = 3.4V, control inputs only). A and B pins do not contribute to ΔI<sub>CC</sub>.
- This current applies to the control inputs only and represents the current required to switch internal capacitance at the specified frequency. The A and B inputs generate no significant AC or DC currents as they transition. This parameter is guaranteed but not production tested.

## SWITCHING CHARACTERISTICS OVER OPERATING RANGE

T<sub>A</sub> = -40°C to +85°C, V<sub>CC</sub> = 5V ± 5%

C<sub>LOAD</sub> = 50pF, R<sub>LOAD</sub> = 500Ω unless otherwise noted.

Symbol	Parameter	Min. <sup>(1)</sup>	Typ.	Max.	Unit
t <sub>PLH</sub> t <sub>PHL</sub>	Data Propagation Delay <sup>(2)</sup> xA to xB	—	—	0.25 <sup>(3)</sup>	ns
t <sub>PZL</sub> t <sub>PZH</sub>	Switch Turn-On Delay OE to xA/xB	1.5	—	6.5	ns
t <sub>PLZ</sub> t <sub>PHZ</sub>	Switch Turn-Off Delay <sup>(2)</sup> OE to xA/xB	1.5	—	5.5	ns

### NOTES:

- Minimums are guaranteed but not production tested.
- This parameter is guaranteed but not production tested.
- The bus switch contributes no propagation delay other than the RC delay of the ON resistance of the switch and the load capacitance. The time constant for the switch alone is of the order of 0.25ns at C<sub>L</sub> = 50pF. Since this time constant is much smaller than the rise and fall times of typical driving signals, it adds very little propagation delay to the system. Propagation delay of the bus switch, when used in a system, is determined by the driving circuit on the driving side of the switch and its interaction with the load on the driven side.

## ORDERING INFORMATION

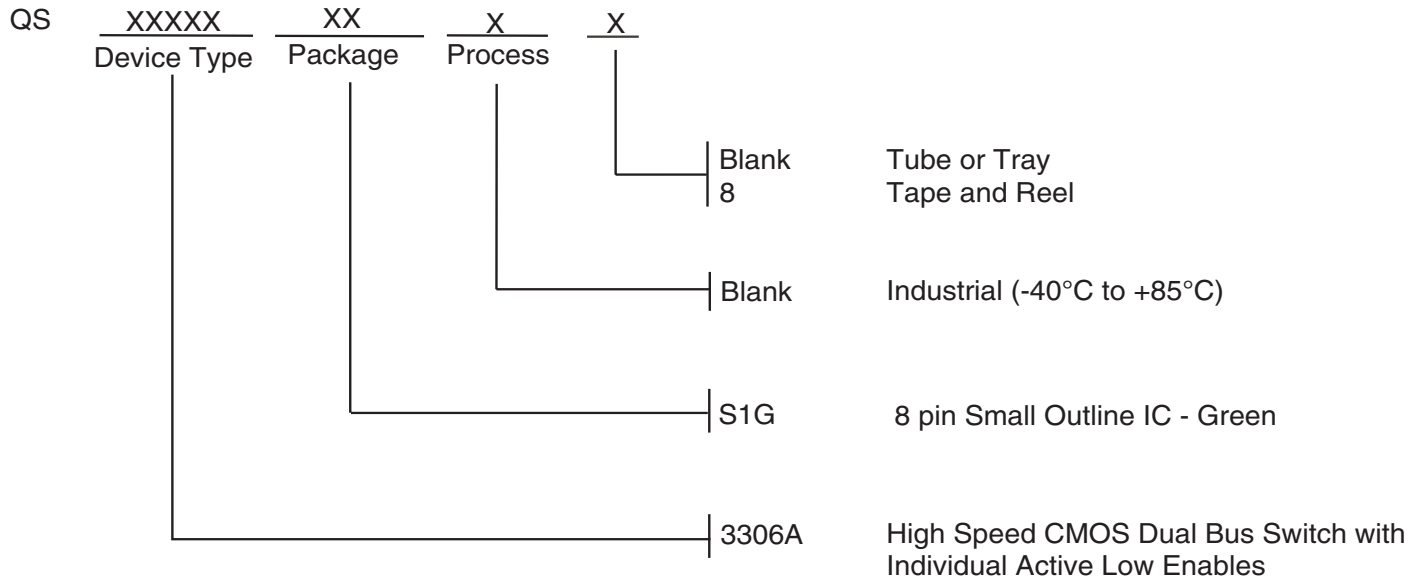

## IMPORTANT NOTICE AND DISCLAIMER

RENESAS ELECTRONICS CORPORATION AND ITS SUBSIDIARIES (“RENESAS”) PROVIDES TECHNICAL SPECIFICATIONS AND RELIABILITY DATA (INCLUDING DATASHEETS), DESIGN RESOURCES (INCLUDING REFERENCE DESIGNS), APPLICATION OR OTHER DESIGN ADVICE, WEB TOOLS, SAFETY INFORMATION, AND OTHER RESOURCES “AS IS” AND WITH ALL FAULTS, AND DISCLAIMS ALL WARRANTIES, EXPRESS OR IMPLIED, INCLUDING, WITHOUT LIMITATION, ANY IMPLIED WARRANTIES OF MERCHANTABILITY, FITNESS FOR A PARTICULAR PURPOSE, OR NON-INFRINGEMENT OF THIRD PARTY INTELLECTUAL PROPERTY RIGHTS.

These resources are intended for developers skilled in the art designing with Renesas products. You are solely responsible for (1) selecting the appropriate products for your application, (2) designing, validating, and testing your application, and (3) ensuring your application meets applicable standards, and any other safety, security, or other requirements. These resources are subject to change without notice. Renesas grants you permission to use these resources only for development of an application that uses Renesas products. Other reproduction or use of these resources is strictly prohibited. No license is granted to any other Renesas intellectual property or to any third party intellectual property. Renesas disclaims responsibility for, and you will fully indemnify Renesas and its representatives against, any claims, damages, costs, losses, or liabilities arising out of your use of these resources. Renesas' products are provided only subject to Renesas' Terms and Conditions of Sale or other applicable terms agreed to in writing. No use of any Renesas resources expands or otherwise alters any applicable warranties or warranty disclaimers for these products.

(Rev.1.0 Mar 2020)

### Corporate Headquarters

TOYOSU FORESIA, 3-2-24 Toyosu,  
Koto-ku, Tokyo 135-0061, Japan  
[www.renesas.com](http://www.renesas.com)

### Contact Information

For further information on a product, technology, the most up-to-date version of a document, or your nearest sales office, please visit:  
[www.renesas.com/contact/](http://www.renesas.com/contact/)

### Trademarks

Renesas and the Renesas logo are trademarks of Renesas Electronics Corporation. All trademarks and registered trademarks are the property of their respective owners.

## X-ON Electronics

Largest Supplier of Electrical and Electronic Components

*Click to view similar products for [Digital Bus Switch ICs](#) category:*

*Click to view products by [Renesas](#) manufacturer:*

Other Similar products are found below :

[MT8986AE1](#) [TC7MPB9307FT\(EL\)](#) [MT8985AE1](#) [MT8986AP1](#) [PI3CH800LE](#) [PI3C32X384BE](#) [ZL50023GAG2](#) [MT8986AL1](#) [MT8981DP1](#)  
[PI3VT3245-ALE](#) [PI3CH800QE](#) [MT90823AB1](#) [PI3VT3245-AQE](#) [PI3CH800QEX](#) [PI3C3384QE](#) [PI3C3305UEX](#) [PI3B3861QE](#)  
[PI3B3245QEX](#) [PI3B3245QE](#) [PI3CH1000LE](#) [PI3CH401LE](#) [PI3CH401LEX](#) [TC7WBL3305CFK\(5L,F](#) [74CB3Q3125DBQRE4](#)  
[TC7WBL3305CFK,LF](#) [SN74CBT16245CDGGR](#) [PI5C3245QE](#) [72V90823PQFG](#) [PI3B3861QEX](#) [PI3C3126QEX](#) [PI3C3245QE](#) [PI5C3384QE](#)  
[PI3CH281QE](#) [QS3VH16244PAG8](#) [PI3CH400LE](#) [PI3B3245LEX](#) [PI3B3245LE](#) [PI3C3306LEX](#) [PI5C3245LEX](#) [PI5C3306LEX](#) [PI3B3126LE](#)  
[PI3B3125LEX](#) [72V73273BBG](#) [74CBTLV3862PGG](#) [QS3126QG](#) [QS32245QG](#) [QS3244QG](#) [QS3245SOG8](#) [QS32X384Q1G](#) [QS3VH126QG](#)