

**FEATURES:**

- Low ON resistance:  $r_{DS(ON)} = 5\Omega$
- Wide bandwidth: 1.3GHz (-3dB point)
- Crosstalk: 100dB at 50KHz, -70dB at 5MHz, -50dB at 30MHz
- Off-isolation: -90dB at 50KHz, -60dB at 5MHz, -55dB at 30MHz
- Single 5V supply
- Bidirectional signal flow
- TTL-compatible control inputs
- Ultra-low quiescent current: 3μA
- Switch turn on time of 6.5ns
- Available in QSOP package

**APPLICATIONS:**

- High-speed video signal switching/routing
- HDTV-quality video signal routing
- Audio signal switching/routing
- Data acquisition
- ATE systems
- Telecomm routing
- Token Ring transceivers
- High-speed networking

**DESCRIPTION:**

The QS4A105 is a high-performance CMOS two-channel 4PST switch with 3-state outputs. The low ON resistance of the QS4A105 allows inputs to be connected to outputs with low insertion loss and high bandwidth.

The QS4A105, with 1.3GHz bandwidth, is ideal for high-performance video signal switching, audio signal switching, and telecomm routing applications. Low power dissipation makes this device ideal for battery operated and remote instrumentation applications.

The QS4A105 is offered in the QSOP package which has several advantages over conventional packages such as PDIP and SOIC, including:

- Reduced signal delays due to denser component packaging on circuit boards
- Reduced system noise due to less pin inductance

The QS4A105 is characterized for operation at -40°C to +85°C.

**FUNCTIONAL BLOCK DIAGRAM**

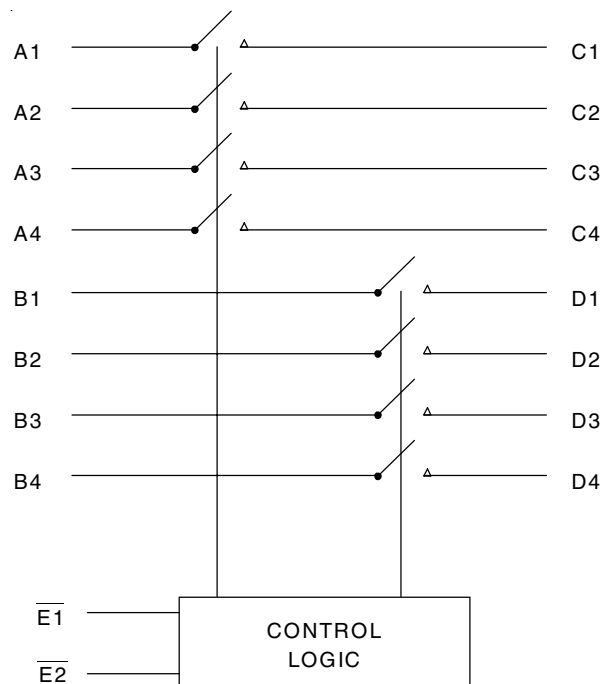

The IDT logo is a registered trademark of Integrated Device Technology, Inc.

## PIN CONFIGURATION

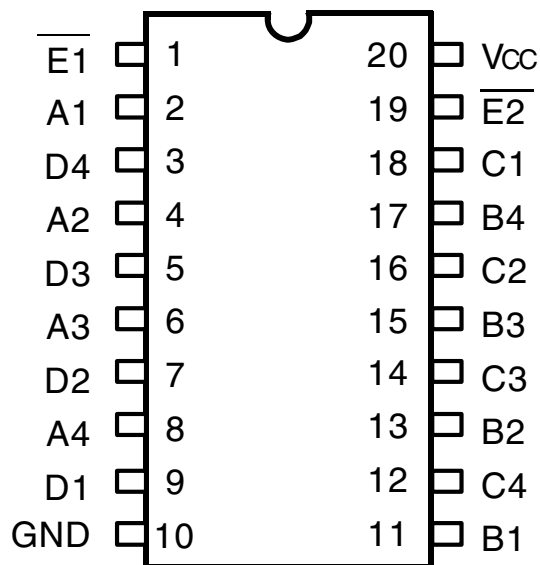

QSOP  
TOP VIEW

## ABSOLUTE MAXIMUM RATINGS(1)

Symbol	Description	Max	Unit
VTERM <sup>(2)</sup>	Supply Voltage to Ground	-0.5 to +7	V
VTERM <sup>(3)</sup>	DC Switch Voltage V <sub>s</sub>	0 to +7	V
—	Analog Input Voltage	0 to +7	V
VTERM <sup>(3)</sup>	DC Input Voltage V <sub>IN</sub>	0 to +7	V
V <sub>AC</sub>	AC Input Voltage (pulse width ≤20ns)	-3	V
I <sub>OUT</sub>	DC Output Current	120	mA
P <sub>MAX</sub>	Maximum Power Dissipation	0.7	W
T <sub>STG</sub>	Storage Temperature	-65 to +150	°C

### NOTES:

- Stresses greater than those listed under ABSOLUTE MAXIMUM RATINGS may cause permanent damage to the device. This is a stress rating only and functional operation of the device at these or any other conditions above those indicated in the operational sections of this specification is not implied. Exposure to absolute maximum rating conditions for extended periods may affect reliability.
- V<sub>cc</sub> terminals.
- All terminals except V<sub>cc</sub>.

## PIN DESCRIPTION

Pin Names	I/O	Description
A <sub>x</sub> , B <sub>x</sub>	I/O	Ports A, B
C <sub>x</sub> , D <sub>x</sub>	I/O	Ports C, D
$\bar{E}_1$ - $\bar{E}_2$	I	Enable

## FUNCTION TABLE(1)

$\bar{E}_1$	$\bar{E}_2$	A <sub>x</sub> , C <sub>x</sub> I/Os	B <sub>x</sub> , D <sub>x</sub> I/Os
H	H	Disconnected	Disconnected
L	H	A <sub>x</sub> = C <sub>x</sub>	Disconnected
H	L	Disconnected	B <sub>x</sub> = D <sub>x</sub>
L	L	A <sub>x</sub> = C <sub>x</sub>	B <sub>x</sub> = D <sub>x</sub>

### NOTE:

- H = HIGH Voltage Level  
L = LOW Voltage Level

## DC ELECTRICAL CHARACTERISTICS OVER OPERATING RANGE

Following Conditions Apply Unless Otherwise Specified:

Industrial: TA = -40°C to +85°C, VCC = 5V ± 5%

Symbol	Parameter	Test Conditions	Min.	Typ. <sup>(1)</sup>	Max.	Unit
<b>Analog Switch</b>						
V <sub>IN</sub>	Analog Signal Range <sup>(2)</sup>		0	—	V <sub>CC</sub> - 1	V
r <sub>DS(ON)</sub>	Drain-source ON resistance <sup>(2,3)</sup>	V <sub>CC</sub> = Min., V <sub>IN</sub> = 0V, I <sub>ON</sub> = 30mA	—	5	7	Ω
		V <sub>CC</sub> = Min., V <sub>IN</sub> = 2.4V, I <sub>ON</sub> = 15mA	—	13	17	
I <sub>C(OFF)</sub>	Channel Off Leakage Current	A <sub>x</sub> , B <sub>x</sub> = V <sub>CC</sub> or 0V, C <sub>x</sub> , D <sub>x</sub> = 0V or V <sub>CC</sub> , $\bar{E}$ = V <sub>CC</sub>	—	1	—	nA
I <sub>C(ON)</sub>	Channel On Leakage Current	A <sub>x</sub> = B <sub>x</sub> = C <sub>x</sub> = D <sub>x</sub> = 0V (each channel is turned on sequentially)	—	1	—	nA
<b>Digital Control</b>						
V <sub>IH</sub>	Input HIGH Voltage	Guaranteed Logic HIGH for Control Pins	2	—	—	V
V <sub>IL</sub>	Input LOW Voltage	Guaranteed Logic LOW for Control Pins	—	—	0.8	V
<b>Dynamic Characteristics</b>						
t <sub>ON(<math>\bar{E}</math>)}</sub>	Enable Turn-On Time $\bar{E}$ to A <sub>x</sub> , B <sub>x</sub> , C <sub>x</sub> , or D <sub>x</sub>	R <sub>L</sub> = 1KΩ, C <sub>L</sub> = 100pF (See Switching Time)	0.5	—	6.5	ns
t <sub>OFF(<math>\bar{E}</math>)}</sub>	Enable Turn-Off Time $\bar{E}$ to A <sub>x</sub> , B <sub>x</sub> , C <sub>x</sub> , or D <sub>x</sub>	R <sub>L</sub> = 1KΩ, C <sub>L</sub> = 100pF (See Switching Time)	0.5	—	6	ns
t <sub>PD</sub>	Group Delay <sup>(2,4a)</sup>	R <sub>L</sub> = 1KΩ, C <sub>L</sub> = 100pF	—	—	250	ps
f <sub>3dB</sub>	-3dB Bandwidth	V <sub>IN</sub> = 0 to 1V, 1Vp-p, R <sub>L</sub> = 75Ω	—	1.3	—	GHz
	Off-isolation	V <sub>IN</sub> = 0 to 1V, 1Vp-p, R <sub>L</sub> = 75Ω, f = 5.5MHz	—	-60	—	dB
X <sub>TALK</sub>	Crosstalk	V <sub>IN</sub> = 1Vp-p, R <sub>L</sub> = 75Ω, f = 5.5MHz	—	-70	—	dB
C <sub>(OFF)</sub>	Mux Off Capacitance	$\bar{E}$ = V <sub>CC</sub> , V <sub>IN</sub> = V <sub>OUT</sub> = 0V	—	5	—	pF
C <sub>(ON)</sub>	Mux On Capacitance	$\bar{E}$ = 0V, V <sub>IN</sub> = V <sub>OUT</sub> = 0V	—	10	—	pF
Q <sub>CI</sub>	Charge Injection	C <sub>L</sub> = 1000pF	—	1.5	—	pC

### NOTES:

1. Typical values are at V<sub>CC</sub> = 5.0V, T<sub>A</sub> = 25°C.
2. Max value is guaranteed but not production tested.
3. Measured by voltage drop between A and C pins or B and D pins at indicated current through the switch. ON resistance is determined by the lower of the voltages on the two (A, C, or B, D) pins.
4. The bus switch contributes no group delay other than the RC delay of the ON resistance of the switch and load capacitance. Group delay of the bus switch, when used in a system, is determined by the driving circuit on the driving side of the switch and its interaction with the load on the driven side.

## POWER SUPPLY CHARACTERISTICS

Symbol	Parameter	Test Conditions	Max.	Unit
I <sub>CC</sub>	Supply Current	V <sub>CC</sub> = Max., V <sub>IN</sub> = GND or V <sub>CC</sub>	3	μA

### TYPICAL CHARACTERISTICS

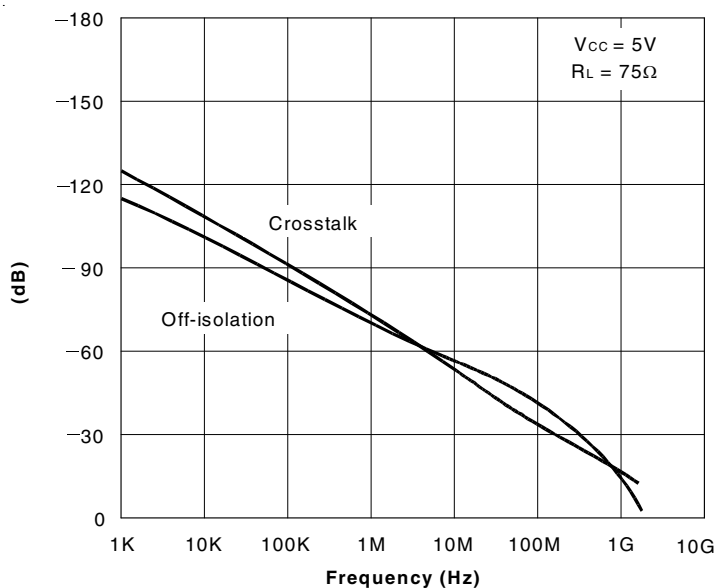

Off-isolation and Crosstalk vs. Frequency

**NOTES:**

1. Crosstalk =  $20 \log |V_o/V_s|$
2. Off-isolation =  $20 \log |V_o/V_s|$

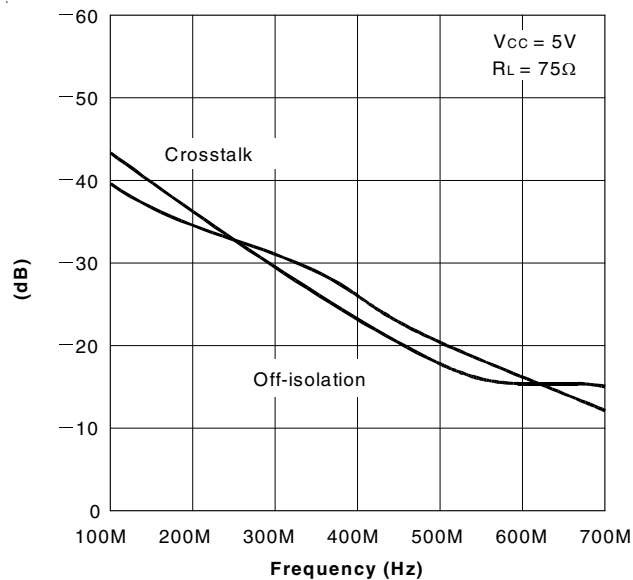

Off-isolation and Crosstalk vs. Frequency

**NOTES:**

1. Crosstalk =  $20 \log |V_o/V_s|$
2. Off-isolation =  $20 \log |V_o/V_s|$

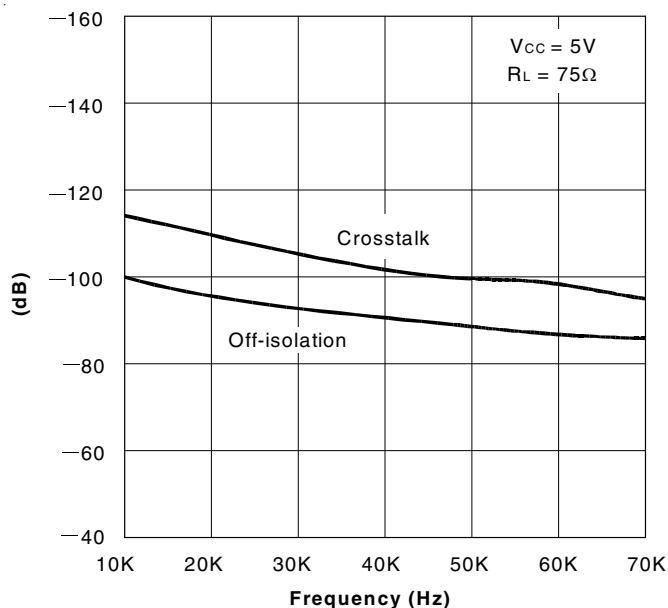

Off-isolation and Crosstalk vs. Frequency

**NOTES:**

1. Crosstalk =  $20 \log |V_o/V_s|$
2. Off-isolation =  $20 \log |V_o/V_s|$

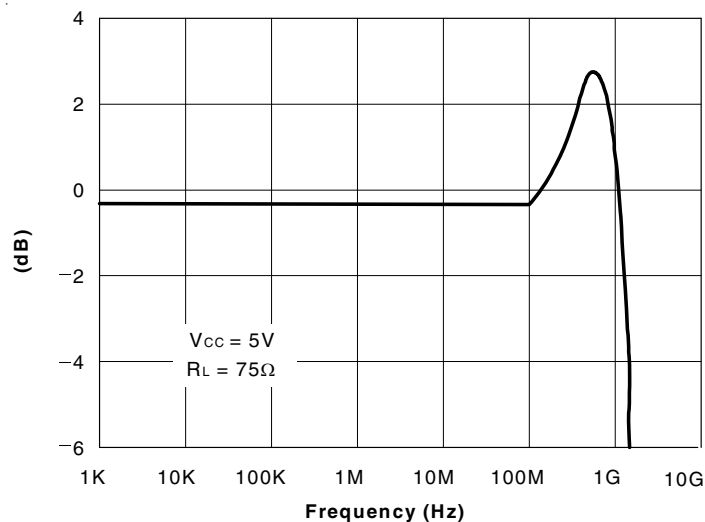

Insertion Loss vs. Frequency

**NOTE:**

1. Insertion Loss =  $20 \log |V_o/V_s|$

### TYPICAL CHARACTERISTICS (CONTINUED)

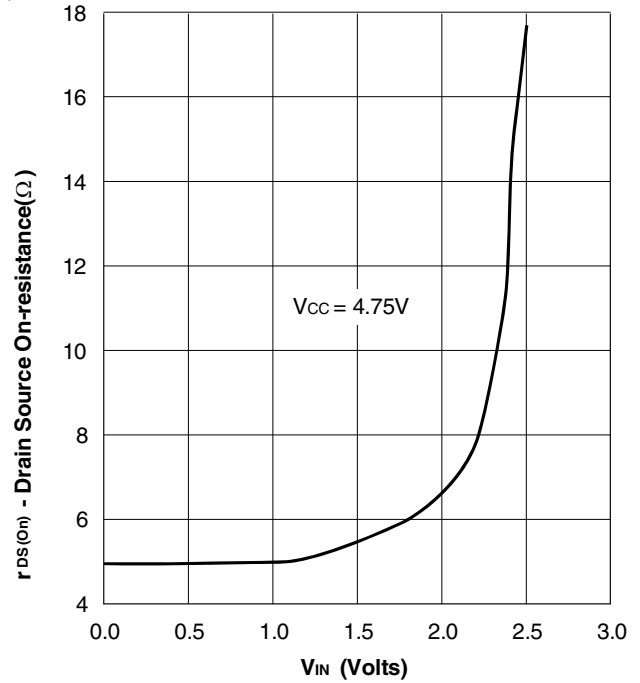
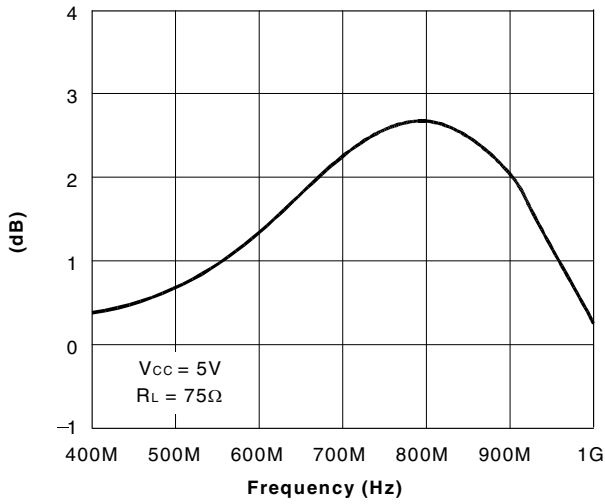

NOTE:  
1. Insertion Loss =  $20 \log |V_o/V_s|$

RON LINK

### TEST CIRCUITS

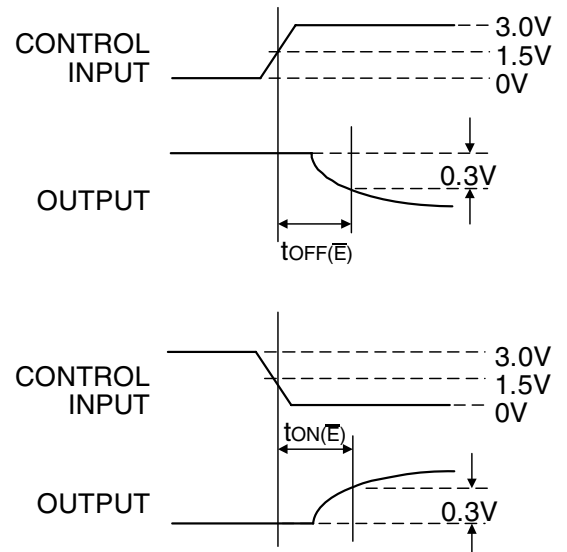
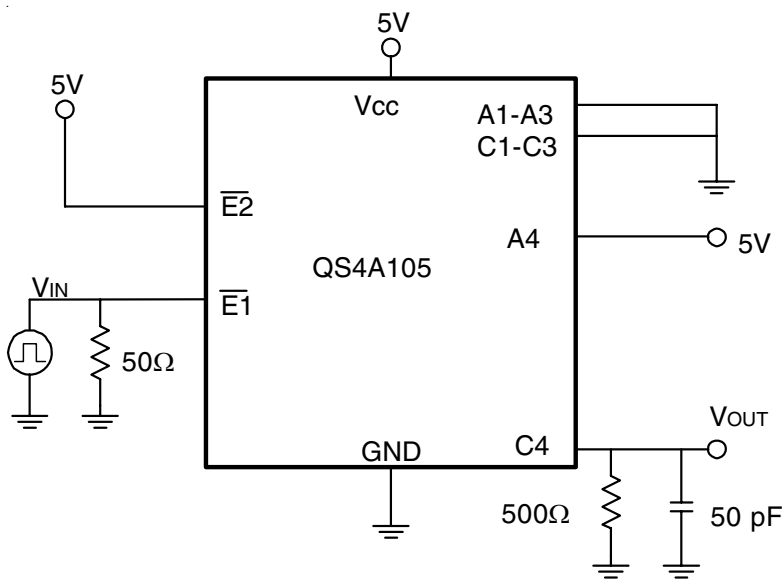

Switching Time

## TEST CIRCUITS (CONTINUED)

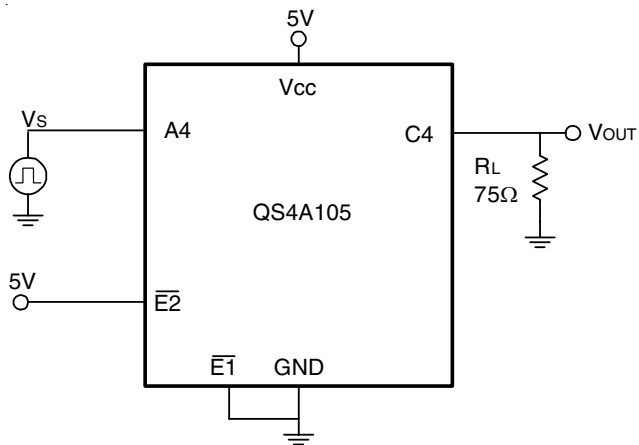

**Insertion Loss**

**NOTES:**

1. Insertion Loss =  $20 \log |V_o/V_s|$
2. All unused pins are grounded.

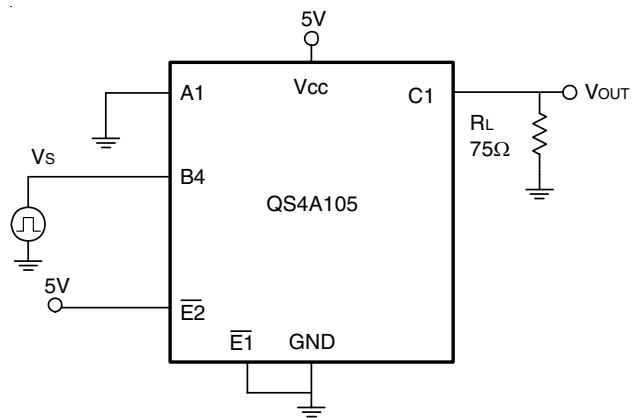

**Crosstalk**

**NOTES:**

1. Crosstalk =  $20 \log |V_o/V_s|$
2. All unused pins are grounded.

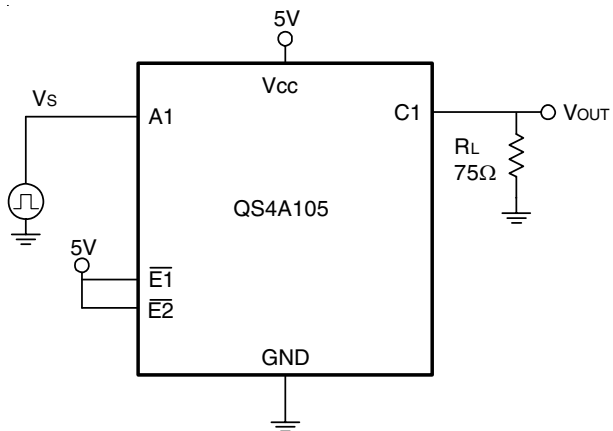

**Off-Isolation**

**NOTE:**

1. Off-isolation =  $20 \log |V_o/V_s|$

## ORDERING INFORMATION

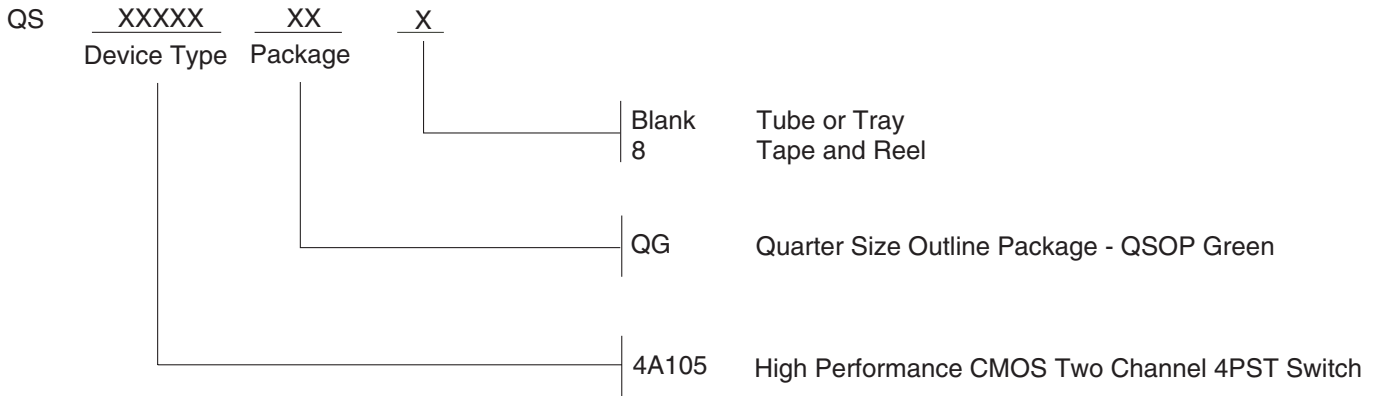

## IMPORTANT NOTICE AND DISCLAIMER

RENESAS ELECTRONICS CORPORATION AND ITS SUBSIDIARIES (“RENESAS”) PROVIDES TECHNICAL SPECIFICATIONS AND RELIABILITY DATA (INCLUDING DATASHEETS), DESIGN RESOURCES (INCLUDING REFERENCE DESIGNS), APPLICATION OR OTHER DESIGN ADVICE, WEB TOOLS, SAFETY INFORMATION, AND OTHER RESOURCES “AS IS” AND WITH ALL FAULTS, AND DISCLAIMS ALL WARRANTIES, EXPRESS OR IMPLIED, INCLUDING, WITHOUT LIMITATION, ANY IMPLIED WARRANTIES OF MERCHANTABILITY, FITNESS FOR A PARTICULAR PURPOSE, OR NON-INFRINGEMENT OF THIRD PARTY INTELLECTUAL PROPERTY RIGHTS.

These resources are intended for developers skilled in the art designing with Renesas products. You are solely responsible for (1) selecting the appropriate products for your application, (2) designing, validating, and testing your application, and (3) ensuring your application meets applicable standards, and any other safety, security, or other requirements. These resources are subject to change without notice. Renesas grants you permission to use these resources only for development of an application that uses Renesas products. Other reproduction or use of these resources is strictly prohibited. No license is granted to any other Renesas intellectual property or to any third party intellectual property. Renesas disclaims responsibility for, and you will fully indemnify Renesas and its representatives against, any claims, damages, costs, losses, or liabilities arising out of your use of these resources. Renesas' products are provided only subject to Renesas' Terms and Conditions of Sale or other applicable terms agreed to in writing. No use of any Renesas resources expands or otherwise alters any applicable warranties or warranty disclaimers for these products.

(Rev.1.0 Mar 2020)

### Corporate Headquarters

TOYOSU FORESIA, 3-2-24 Toyosu,  
Koto-ku, Tokyo 135-0061, Japan  
[www.renesas.com](http://www.renesas.com)

### Contact Information

For further information on a product, technology, the most up-to-date version of a document, or your nearest sales office, please visit:  
[www.renesas.com/contact/](http://www.renesas.com/contact/)

### Trademarks

Renesas and the Renesas logo are trademarks of Renesas Electronics Corporation. All trademarks and registered trademarks are the property of their respective owners.



## X-ON Electronics

Largest Supplier of Electrical and Electronic Components

*Click to view similar products for [Analogue Switch ICs](#) category:*

*Click to view products by [Renesas](#) manufacturer:*

Other Similar products are found below :

[FSA3051TMX](#) [NLAS4684FCTCG](#) [NLAS5223BLMNR2G](#) [NLVAS4599DTT1G](#) [NLX2G66DMUTCG](#) [425541DB](#) [425528R](#) [099044FB](#)  
[NLAS5123MNR2G](#) [PI5A4599BCEX](#) [NLAS4717EPFCT1G](#) [PI5A3167CCEX](#) [SLAS3158MNR2G](#) [PI5A392AQE](#) [PI5A4157ZUEX](#)  
[PI5A3166TAEX](#) [FSA634UCX](#) [TC4066BP\(N,F\)](#) [DG302BDJ-E3](#) [PI5A100QEX](#) [HV2605FG-G](#) [HV2301FG-G](#) [RS2117YUTQK10](#)  
[RS2118YUTQK10](#) [RS2227XUTQK10](#) [ADG452BRZ-REEL7](#) [MAX4066ESD+](#) [MAX391CPE+](#) [MAX4730EXT+T](#) [MAX314CPE+](#)  
[BU4066BCFV-E2](#) [MAX313CPE+](#) [BU4S66G2-TR](#) [NLAS3158MNR2G](#) [NLASB3157MTR2G](#) [TS3A4751PWR](#) [NLAS4157DFT2G](#)  
[NLAS4599DFT2G](#) [NLAST4599DFT2G](#) [NLAST4599DTT1G](#) [DG300BDJ-E3](#) [DG2503DB-T2-GE1](#) [DG2502DB-T2-GE1](#)  
[TC4W53FU\(TE12L,F\)](#) [74HC2G66DC.125](#) [ADG619BRMZ-REEL](#) [ADG1611BRUZ-REEL7](#) [LTC201ACN#PBF](#) [74LV4066DB,118](#)  
[FSA2275AUMX](#)