

FEATURES:

- Low ON resistance: $r_{DS(ON)} = 5\Omega$
- Fast transition time: $t_{TRAN} = 6ns$
- Wide bandwidth: 700MHz (-3dB point)
- Crosstalk: -110dB at 50KHz, -68dB at 5MHz, -66dB at 30MHz
- Off-isolation: -90dB at 50KHz, -60dB at 5MHz, -50dB at 30MHz
- Single 5V supply
- Can be used as multiplexer or demultiplexer
- TTL-compatible control inputs
- Ultra-low quiescent current: 3 μ A
- Available in QSOP package

APPLICATIONS:

- High-speed video signal switching/routing
- HDTV-quality video signal multiplexing
- Audio signal switching/routing
- Data acquisition
- ATE systems
- Telecomm routing
- Switch between multiple video sources
- Token Ring transceivers
- High-speed networking

DESCRIPTION:

The QS4A210 is a high-performance CMOS two-channel SP4T multiplexer/demultiplexer with individual enables. The low On-resistance of the QS4A210 allows inputs to be connected to outputs with low insertion loss and high bandwidth. TTL-compatible control circuitry with "Break-Before-Make" feature prevents contention.

The QS4A210 with 700MHz bandwidth makes it ideal for high-performance video signal switching, audio signal switching, and telecom routing applications. Low power dissipation makes this device ideal for battery operated and remote instrumentation applications.

The QS4A210 is offered in the QSOP package which has several advantages over conventional packages such as PDIP and SOIC, including:

- Reduced signal delays due to denser component packaging on circuit boards
- Reduced system noise due to less pin inductance, resulting in lower ground bounce

The QS4A210 is characterized for operation at -40°C to +85°C.

FUNCTIONAL BLOCK DIAGRAM

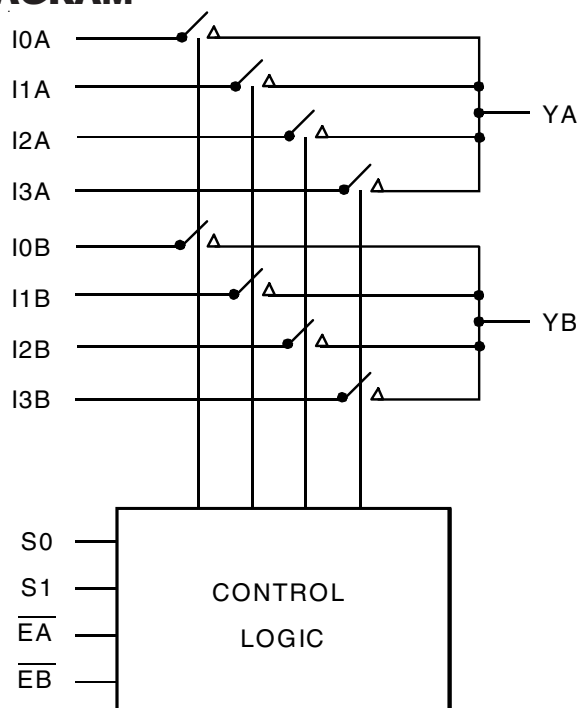

IDT and the IDT logo are registered trademarks of Integrated Device Technology, Inc.

PIN CONFIGURATION

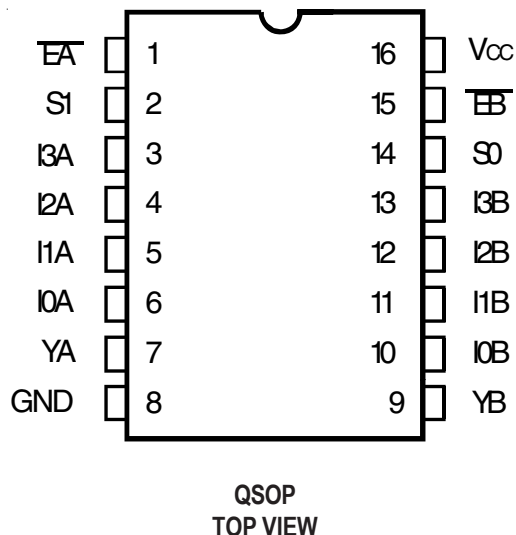

ABSOLUTE MAXIMUM RATINGS⁽¹⁾

Symbol	Description	Max	Unit
VTERM ⁽²⁾	Supply Voltage to Ground	-0.5 to +7	V
VTERM ⁽³⁾	DC Switch Voltage Vs	-0.5 to +7	V
—	Analog Input Voltage	-0.5 to +7	V
VTERM ⁽³⁾	DC Input Voltage VIN	-0.5 to +7	V
VAC	AC Input Voltage (pulse width ≤20ns)	-3	V
IOUT	DC Output Current	120	mA
PMAX	Maximum Power Dissipation	0.7	W
TSTG	Storage Temperature	-65 to +150	°C

NOTES:

- Stresses greater than those listed under ABSOLUTE MAXIMUM RATINGS may cause permanent damage to the device. This is a stress rating only and functional operation of the device at these or any other conditions above those indicated in the operational sections of this specification is not implied. Exposure to absolute maximum rating conditions for extended periods may affect reliability.
- Vcc terminals.
- All terminals except Vcc .

PIN DESCRIPTION

Pin Names	I/O	Description
IxA	I/O	Demux Port A
IxB	I/O	Demux Port B
\overline{EA} , \overline{EB}	I	Enable Inputs
S0, S1	I	Select Inputs
YA, YB	I/O	Mux Port A, B

FUNCTION TABLE⁽¹⁾

Enable		Select		Mux/Demux Ports		Function
\overline{EA}	\overline{EB}	S1	S0	YA	YB	
H	X	X	X	Z	X	Disable A
X	H	X	X	X	Z	Disable B
L	L	L	L	I0A	I0B	S1 - 0 = 0
L	L	L	H	I1A	I1B	S1 - 0 = 1
L	L	H	L	I2A	I2B	S1 - 0 = 2
L	L	H	H	I3A	I3B	S1 - 0 = 3

NOTE:

- H = HIGH Voltage Level
L = LOW Voltage Level
X = Don't Care
Z = High-Impedance

DC ELECTRICAL CHARACTERISTICS OVER OPERATING RANGE

Following Conditions Apply Unless Otherwise Specified:

Industrial: $T_A = -40^{\circ}\text{C}$ to $+85^{\circ}\text{C}$, $V_{CC} = 5\text{V} \pm 5\%$

Symbol	Parameter	Test Conditions	Min.	Typ. ⁽¹⁾	Max.	Unit
Analog Switch						
V_{IN}	Analog Signal Range ⁽²⁾		-0.5	1	$V_{CC} - 1$	V
$r_{DS(ON)}$	Drain-source ON resistance ^(2,3)	$V_{CC} = \text{Min.}, V_{IN} = 0\text{V}, I_{ON} = 30\text{mA}$	—	5	7	Ω
		$V_{CC} = \text{Min.}, V_{IN} = 2.4\text{V}, I_{ON} = 15\text{mA}$	—	13	17	
$I_{C(OFF)}$	Channel Off Leakage Current	$I_N = V_{CC}$ or 0V ; $Y_N = 0\text{V}$ or V_{CC} ; $\overline{E_A} = \overline{E_B} = V_{CC}$	—	2	—	nA
$I_{C(ON)}$	Channel On Leakage Current	$I_N = Y_N = 0\text{V}$ (each channel is turned on sequentially)	—	2	—	nA
Digital Control						
V_{IH}	Input HIGH Voltage	Guaranteed Logic HIGH for Control Pins	2	—	—	V
V_{IL}	Input LOW Voltage	Guaranteed Logic LOW for Control Pins	—	—	0.8	V
Dynamic Characteristics						
t_{TRANS}	Switching Time of Mux Sx to Y	$R_L = 1\text{K}\Omega, C_L = 100\text{pF}$ (See Transition Time)	0.5	—	6.6	ns
$t_{ON(\overline{EN})}$	Enable Turn-On Time $\overline{E_A} = \overline{E_B}$ to Y	$R_L = 1\text{K}\Omega, C_L = 100\text{pF}$ (See Switching Time)	0.5	—	6	ns
$t_{OFF(\overline{EN})}$	Enable Turn-Off Time $\overline{E_A} = \overline{E_B}$ to Y	$R_L = 1\text{K}\Omega, C_L = 100\text{pF}$ (See Switching Time)	0.5	—	6	ns
t_{PD}	Group Delay ^(2,4)	$R_L = 1\text{K}\Omega, C_L = 100\text{pF}$	—	—	250	ps
f_{dB}	-3dB Bandwidth	$V_{IN} = 1\text{Vp-p}, R_L = 75\Omega$	—	700	—	MHz
	Off-isolation	$V_{IN} = 1\text{Vp-p}, R_L = 75\Omega, f = 5.5\text{MHz}$	—	-60	—	dB
X TALK	Crosstalk	$V_{IN} = 1\text{Vp-p}, R_L = 75\Omega, f = 5.5\text{MHz}$	—	-68	—	dB
$C_{MUX(OFF)}$	Mux Off Capacitance	$\overline{E_A} = \overline{E_B} = V_{CC}, V_{IN} = V_{OUT} = 0\text{V}$	—	5.6	—	pF
$C_{DEMUX(OFF)}$	Demux Off Capacitance	$\overline{E_A} = \overline{E_B} = V_{CC}, V_{IN} = V_{OUT} = 0\text{V}$	—	7.4	—	pF
$C_{MUX(ON)}$	Mux On Capacitance	$\overline{E_A} = \overline{E_B} = 0\text{V}, V_{IN} = V_{OUT} = 0\text{V}$	—	12	—	pF
$C_{DEMUX(ON)}$	Demux On Capacitance	$\overline{E_A} = \overline{E_B} = 0\text{V}, V_{IN} = V_{OUT} = 0\text{V}$	—	15	—	pF
QCI	Charge Injection		—	1.5	—	pC

NOTES:

- Typical values are at $V_{CC} = 5.0\text{V}$, $T_A = 25^{\circ}\text{C}$.
- Max value is guaranteed but not production tested.
- Measured by voltage drop between A and C pins or B and D pins at indicated current through the switch. ON resistance is determined by the lower of the voltages on the two (I, Y) pins.
- The bus switch contributes no group delay other than the RC delay of the ON resistance of the switch and load capacitance. Group delay of the bus switch, when used in a system, is determined by the driving circuit on the driving side of the switch and its interaction with the load on the driven side.

POWER SUPPLY CHARACTERISTICS

Symbol	Parameter	Test Conditions	Max.	Unit
I_{CCQ}	Quiescent Power	$V_{CC} = \text{Max.}, V_{IN} = \text{GND}$ or $V_{CC}, f = 0$	3	μA

TYPICAL CHARACTERISTICS

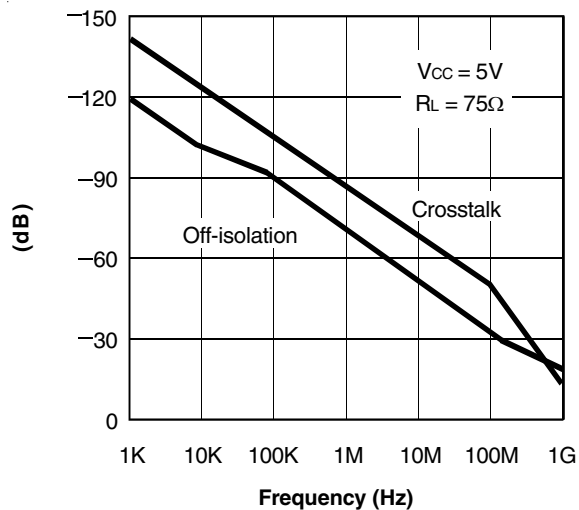

Off-isolation and Crosstalk vs. Frequency

NOTES:

1. Crosstalk = $20 \log |V_o/V_s|$
2. Off-isolation = $20 \log |V_o/V_s|$

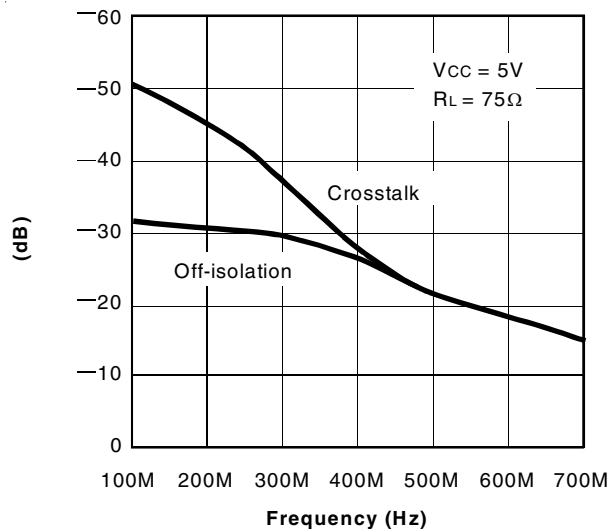

Off-isolation and Crosstalk vs. Frequency

NOTES:

1. Crosstalk = $20 \log |V_o/V_s|$
2. Off-isolation = $20 \log |V_o/V_s|$

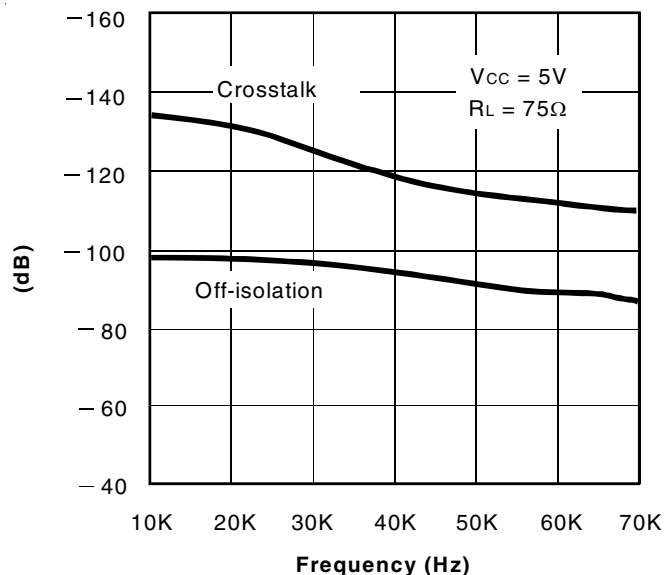

Off-isolation and Crosstalk vs. Frequency

NOTES:

1. Crosstalk = $20 \log |V_o/V_s|$
2. Off-isolation = $20 \log |V_o/V_s|$

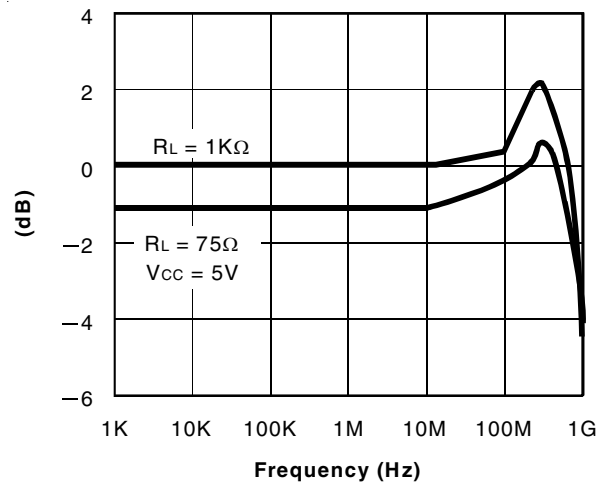

Insertion Loss vs. Frequency

NOTE:

1. Insertion Loss = $20 \log |V_o/V_s|$

TYPICAL CHARACTERISTICS (CONTINUED)

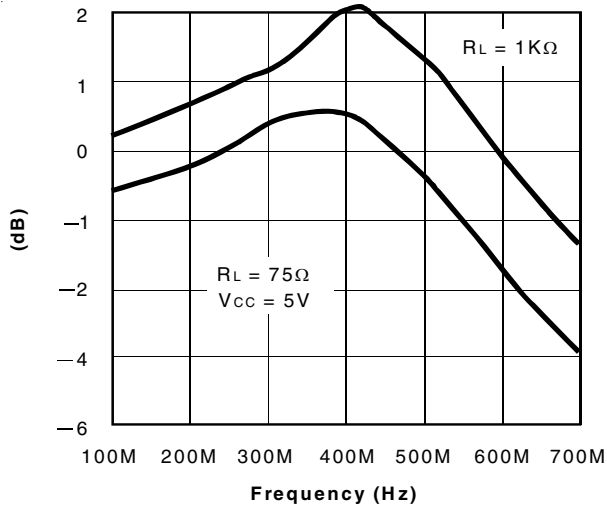

Insertion Loss vs. Frequency

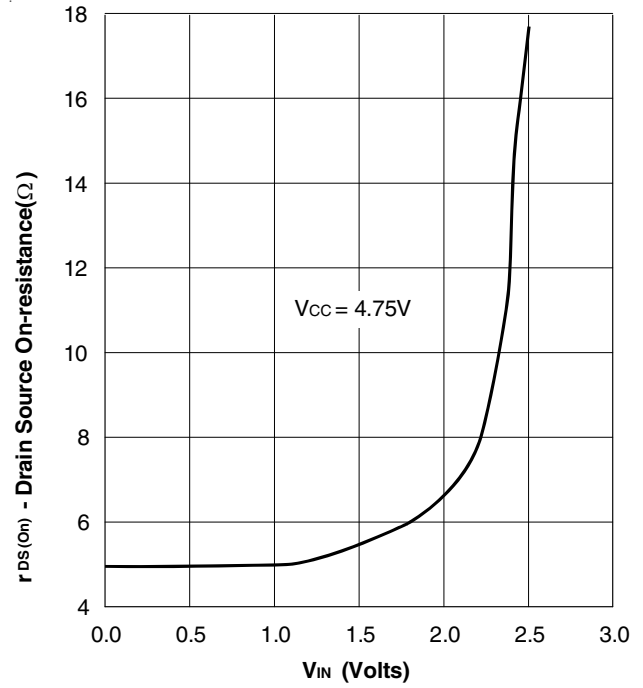

On-Resistance vs. VIN

NOTE:
1. Insertion Loss = $20 \log |V_o/V_s|$

RON LINK

TEST CIRCUITS

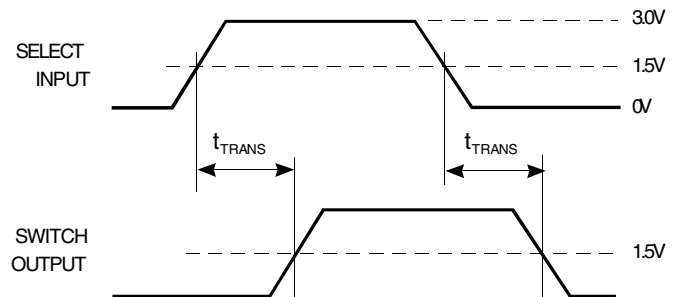
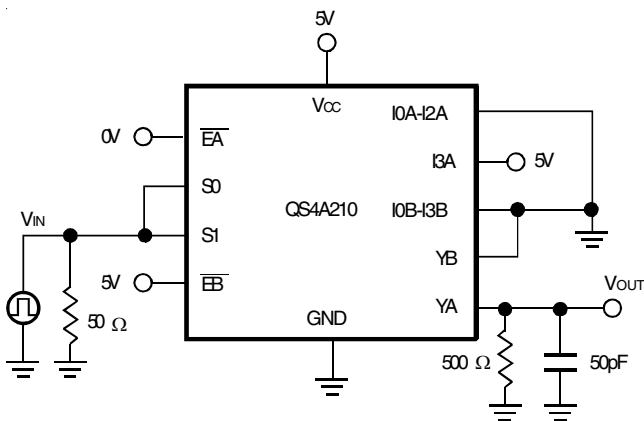

Transition Time

TEST CIRCUITS (CONTINUED)

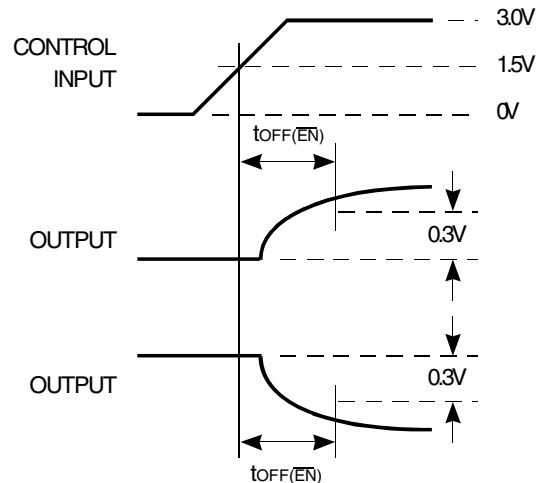
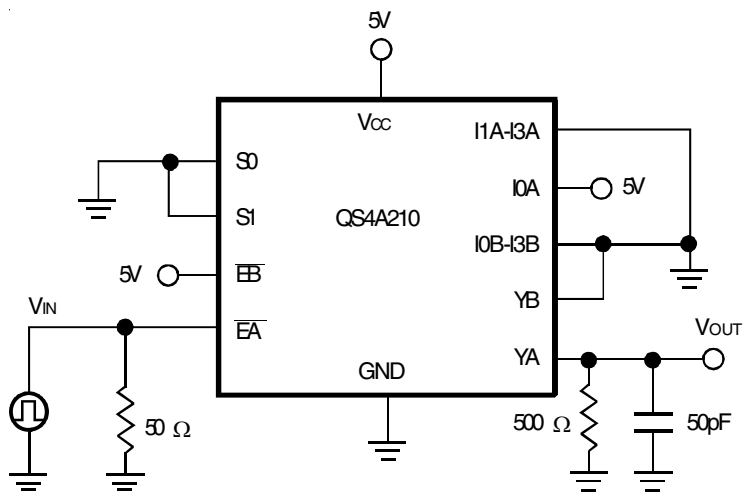

Enable Switching Time

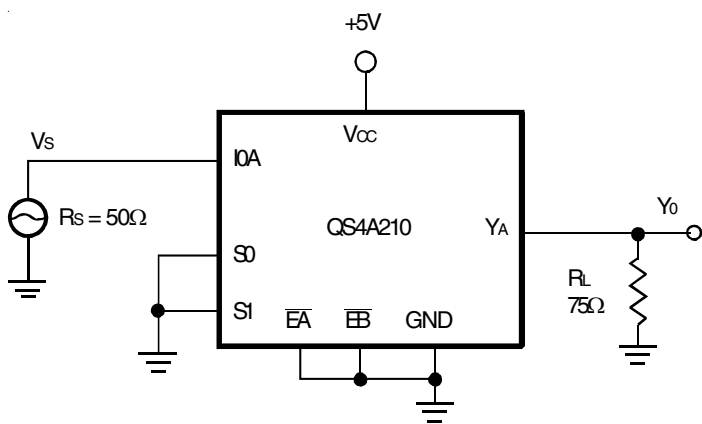

Insertion Loss

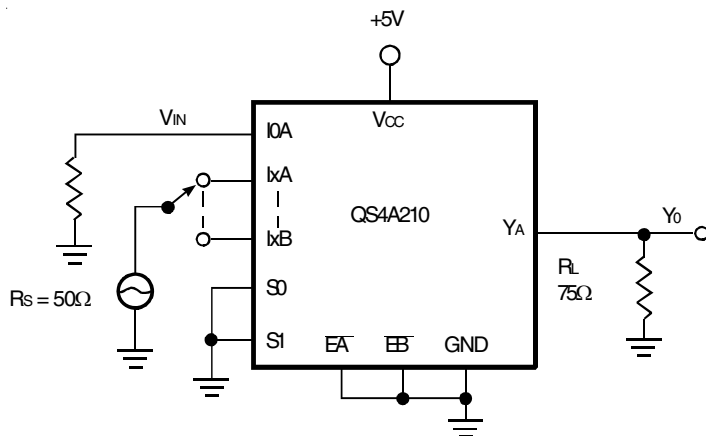

Crosstalk

NOTE:
1. Insertion Loss = $20 \log |V_o/V_s|$

NOTE:
1. Crosstalk = $20 \log |V_o/V_s|$

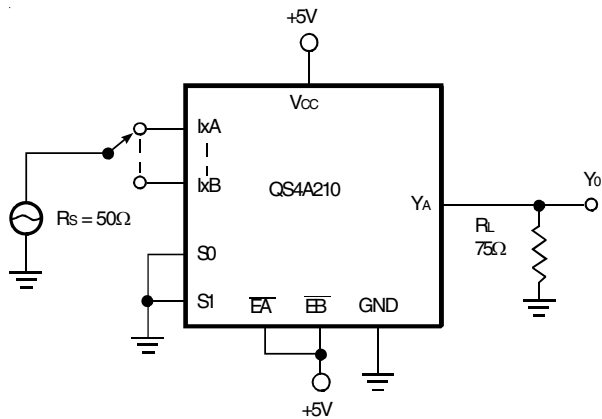

Off-Isolation

NOTE:
1. Off-isolation = $20 \log |V_o/V_s|$

ORDERING INFORMATION

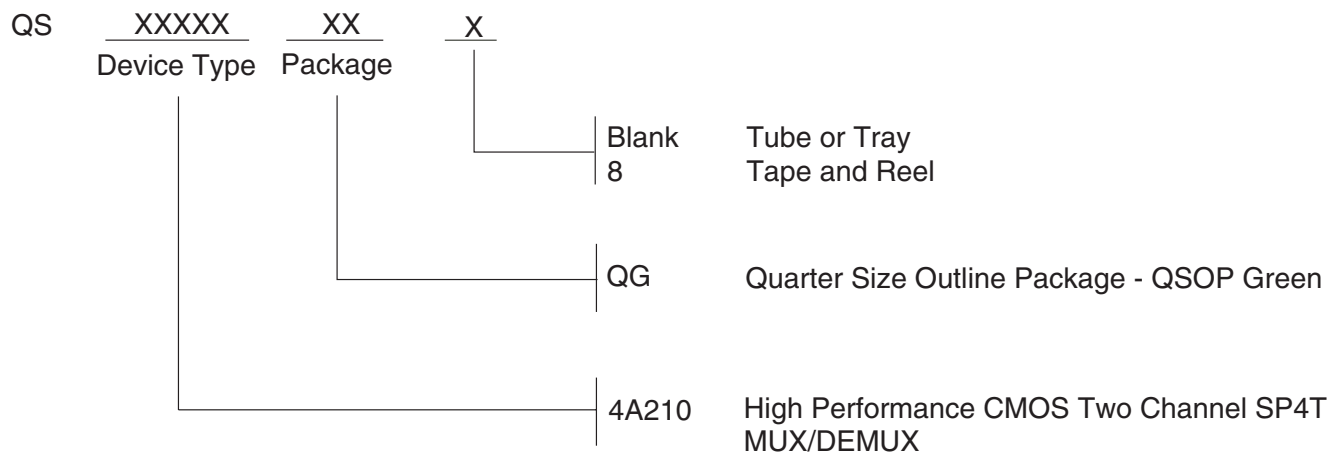

DATASHEET DOCUMENT HISTORY

04/13/2014	Pg. 7	Updated the Ordering Information by removing non green package version, the "IDT" notation and Adding Tape and Reel information.
------------	-------	--

IMPORTANT NOTICE AND DISCLAIMER

RENESAS ELECTRONICS CORPORATION AND ITS SUBSIDIARIES (“RENESAS”) PROVIDES TECHNICAL SPECIFICATIONS AND RELIABILITY DATA (INCLUDING DATASHEETS), DESIGN RESOURCES (INCLUDING REFERENCE DESIGNS), APPLICATION OR OTHER DESIGN ADVICE, WEB TOOLS, SAFETY INFORMATION, AND OTHER RESOURCES “AS IS” AND WITH ALL FAULTS, AND DISCLAIMS ALL WARRANTIES, EXPRESS OR IMPLIED, INCLUDING, WITHOUT LIMITATION, ANY IMPLIED WARRANTIES OF MERCHANTABILITY, FITNESS FOR A PARTICULAR PURPOSE, OR NON-INFRINGEMENT OF THIRD PARTY INTELLECTUAL PROPERTY RIGHTS.

These resources are intended for developers skilled in the art designing with Renesas products. You are solely responsible for (1) selecting the appropriate products for your application, (2) designing, validating, and testing your application, and (3) ensuring your application meets applicable standards, and any other safety, security, or other requirements. These resources are subject to change without notice. Renesas grants you permission to use these resources only for development of an application that uses Renesas products. Other reproduction or use of these resources is strictly prohibited. No license is granted to any other Renesas intellectual property or to any third party intellectual property. Renesas disclaims responsibility for, and you will fully indemnify Renesas and its representatives against, any claims, damages, costs, losses, or liabilities arising out of your use of these resources. Renesas' products are provided only subject to Renesas' Terms and Conditions of Sale or other applicable terms agreed to in writing. No use of any Renesas resources expands or otherwise alters any applicable warranties or warranty disclaimers for these products.

(Rev.1.0 Mar 2020)

Corporate Headquarters

TOYOSU FORESIA, 3-2-24 Toyosu,
Koto-ku, Tokyo 135-0061, Japan
www.renesas.com

Contact Information

For further information on a product, technology, the most up-to-date version of a document, or your nearest sales office, please visit:
www.renesas.com/contact/

Trademarks

Renesas and the Renesas logo are trademarks of Renesas Electronics Corporation. All trademarks and registered trademarks are the property of their respective owners.

X-ON Electronics

Largest Supplier of Electrical and Electronic Components

Click to view similar products for [Multiplexer Switch ICs](#) category:

Click to view products by [Renesas](#) manufacturer:

Other Similar products are found below :

[NLV74HC4066ADR2G](#) [HEF4051BP](#) [MC74HC4067ADTG](#) [DG508AAK/883B](#) [NLV14051BDG](#) [016400E](#) [PI3V512QE](#) [7705201EC](#)
[PI2SSD3212NCE](#) [NLAS3257CMX2TCG](#) [PI3DBS12412AZLEX](#) [PI3V512QEX](#) [PI3DBS16213ZLEX](#) [PI3DBS16415ZHEX](#)
[MUX36S16IRSNR](#) [TC7W53FK,LF](#) [CD4053BM96](#) [MC74HC4053ADWR2G](#) [SN74LV4051APWR](#) [HEF4053BT.653](#) [PI3L720ZHEX](#)
[ADG5408BRUZ-REEL7](#) [ADG1404YRUZ-REEL7](#) [ADG1208YRZ-REEL7](#) [MAX4704EUB+T](#) [ADG1406BRUZ-REEL7](#)
[LTC4305IDHD#PBF](#) [CD4053BPWRG4](#) [74HC4053D.653](#) [74HCT4052PW.118](#) [74LVC2G53DP.125](#) [74HC4052DB.112](#) [74HC4052PW.112](#)
[74HC4053DB.112](#) [74HC4067DB.112](#) [74HC4351DB.112](#) [74HCT4052D.112](#) [74HCT4052DB.112](#) [74HCT4053DB.112](#) [74HCT4067D.112](#)
[74HCT4351D.112](#) [74LV4051PW.112](#) [FSA1256L8X_F113](#) [PI5V330QE](#) [PI5V331QE](#) [5962-8771601EA](#) [5962-87716022A](#) [ADG5249FBRUZ](#)
[ADG1438BRUZ](#) [AD7506JNZ](#)