

RMLV0408E Series

4Mb Advanced LPSRAM (512-kword × 8-bit)

R10DS0206EJ0300
Rev.3.00
2021.8.18

Description

The RMLV0408E Series is a family of 4-Mbit static RAMs organized 524,288-word × 8-bit, fabricated by Renesas's high-performance Advanced LPSRAM technologies. The RMLV0408E Series has realized higher density, higher performance and low power consumption. The RMLV0408E Series offers low power standby power dissipation; therefore, it is suitable for battery backup systems. It is offered in 32-pin SOP, 32-pin TSOP (II) or 32-pin sTSOP.

Features

- Single 3V supply: 2.7V to 3.6V
- Access time: 45ns (max.)
- Current consumption:
 - Standby: 0.3μA (typ.)
- Equal access and cycle times
- Common data input and output
 - Three state output
- Directly TTL compatible
 - All inputs and outputs
- Battery backup operation

Orderable part number information

Orderable part number	Access time	Temperature range	Package	Shipping container
RMLV0408EGSA-4S2#AA*	45 ns	-40 ~ +85°C	8mm×13.4mm 32-pin plastic sTSOP	Tray
RMLV0408EGSA-4S2#KA*				Embossed tape
RMLV0408EGSB-4S2#AA*			400-mil 32pin plastic TSOP (II)	Tray
RMLV0408EGSB-4S2#HA*				Embossed tape
RMLV0408EGSP-4S2#CA*			525-mil 32-pin plastic SOP	Tube
RMLV0408EGSP-4S2#HA*				Embossed tape

Note 1. * = Revision code for Assembly site change, etc. (* = 0, 1, etc.)

Pin Arrangement

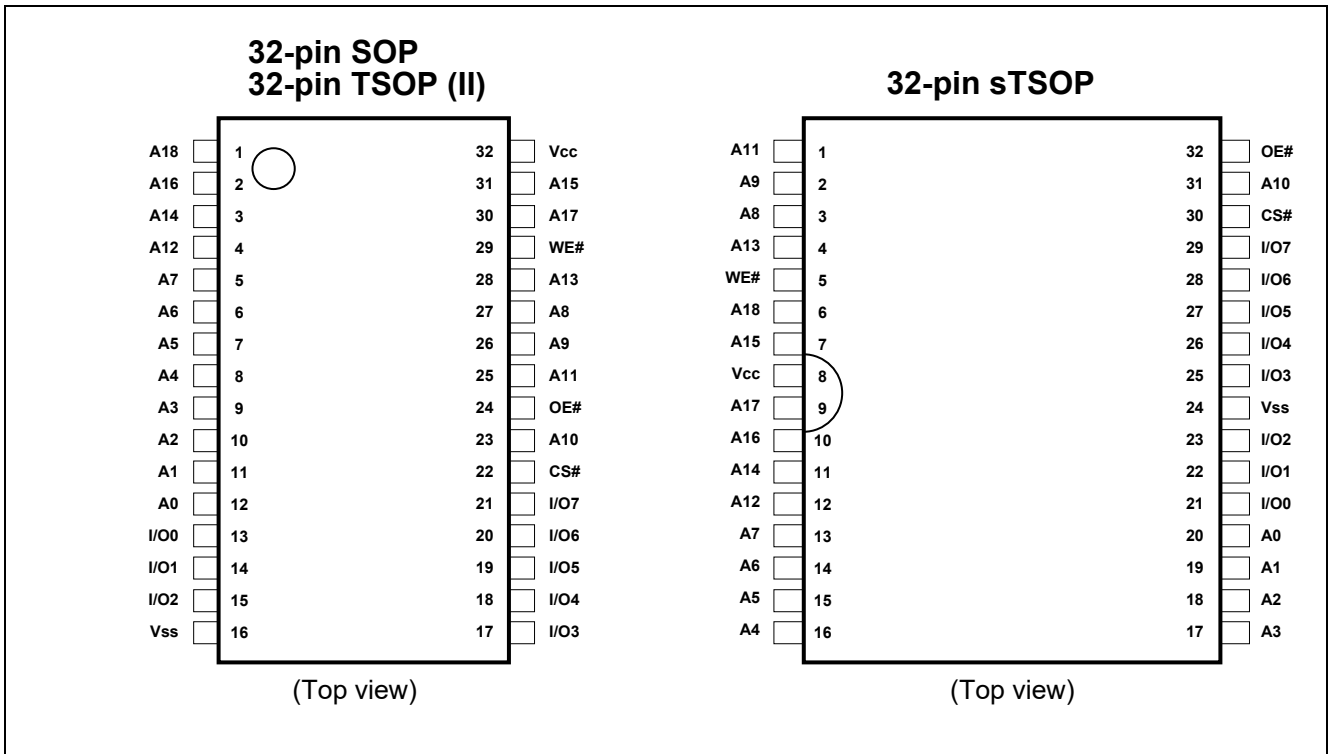

Pin Description

Pin name	Function
Vcc	Power supply
Vss	Ground
A0 to A18	Address input
I/O0 to I/O7	Data input/output
CS#	Chip select
WE#	Write enable
OE#	Output enable

Block Diagram

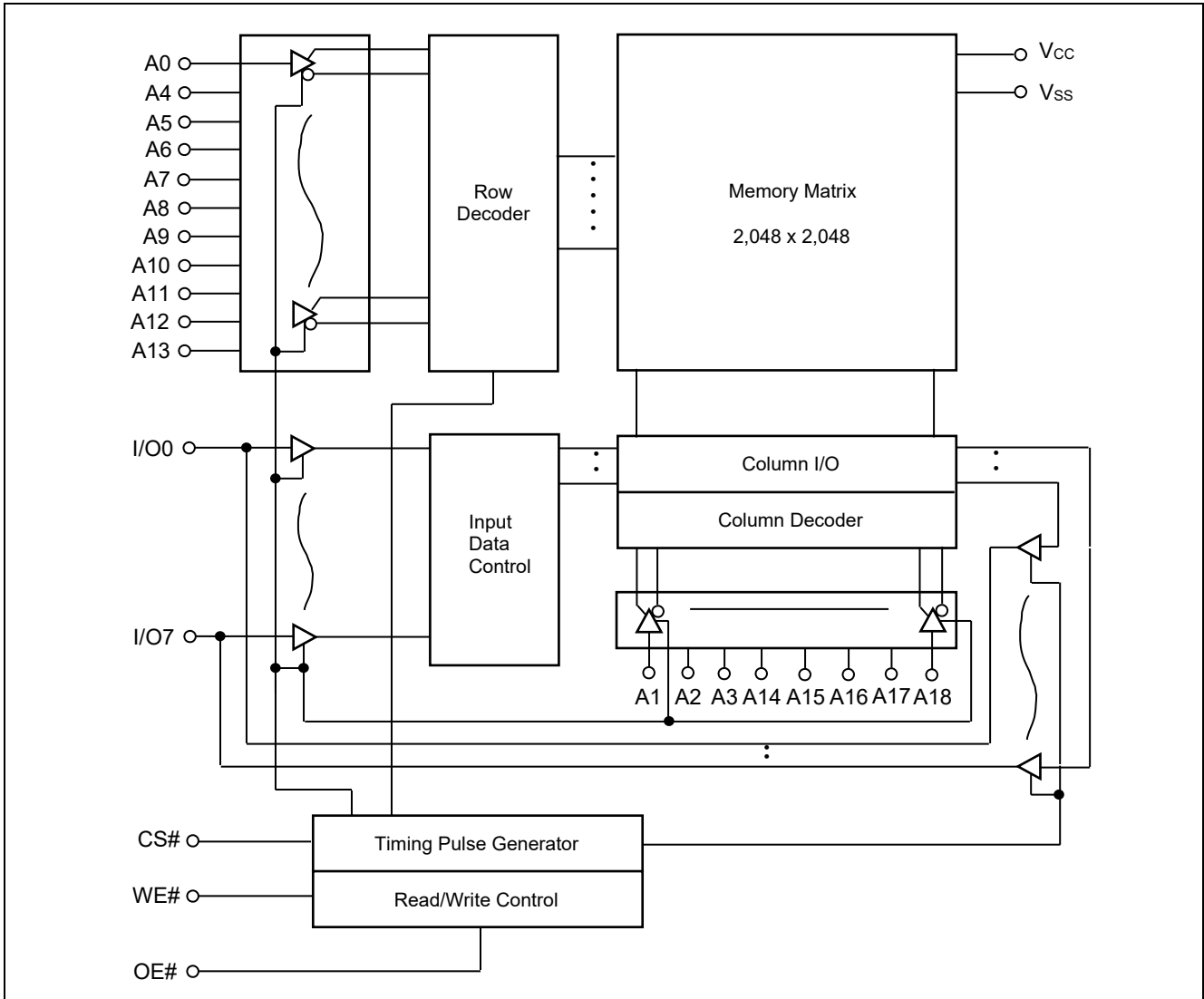

Operation Table

CS#	WE#	OE#	I/O0 to I/O7	Operation
H	X	X	High-Z	Standby
L	H	L	Dout	Read
L	L	X	Din	Write
L	H	H	High-Z	Output disable

Note 2. H: V_{IH} L: V_{IL} X: V_{IH} or V_{IL}

Absolute Maximum Ratings

Parameter	Symbol	Value	unit
Power supply voltage relative to V_{SS}	V_{CC}	-0.5 to +4.6	V
Terminal voltage on any pin relative to V_{SS}	V_T	-0.5 ³ to $V_{CC}+0.3$ ⁴	V
Power dissipation	P_T	0.7	W
Operation temperature	T_{opr}	-40 to +85	°C
Storage temperature range	T_{stg}	-65 to +150	°C
Storage temperature range under bias	T_{bias}	-40 to +85	°C

Note 3. -3.0V for pulse ≤ 30 ns (full width at half maximum)

4. Maximum voltage is +4.6V.

DC Operating Conditions

Parameter	Symbol	Min.	Typ.	Max.	Unit	Note
Supply voltage	V _{CC}	2.7	3.0	3.6	V	
	V _{SS}	0	0	0	V	
Input high voltage	V _{IH}	2.2	—	V _{CC} +0.3	V	
Input low voltage	V _{IL}	-0.3	—	0.6	V	5
Ambient temperature range	T _a	-40	—	+85	°C	

Note 5. -3.0V for pulse ≤ 30ns (full width at half maximum)

DC Characteristics

Parameter	Symbol	Min.	Typ.	Max.	Unit	Test conditions	
Input leakage current	I _{LI}	—	—	1	μA	V _{in} = V _{SS} to V _{CC}	
Output leakage current	I _{LO}	—	—	1	μA	CS# = V _{IH} or OE# = V _{IH} or WE# = V _{IL} , V _{I/O} = V _{SS} to V _{CC}	
Operating current	I _{CC}	—	—	10	mA	CS# = V _{IL} , Others = V _{IH} /V _{IL} , I _{I/O} = 0mA	
Average operating current	I _{CC1}	—	—	20	mA	Cycle = 55ns, duty = 100%, I _{I/O} = 0mA, CS# = V _{IL} , Others = V _{IH} /V _{IL}	
		—	—	25	mA	Cycle = 45ns, duty = 100%, I _{I/O} = 0mA, CS# = V _{IL} , Others = V _{IH} /V _{IL}	
	I _{CC2}	—	—	2.5	mA	Cycle = 1μs, duty = 100%, I _{I/O} = 0mA, CS# ≤ 0.2V, V _{IH} ≥ V _{CC} -0.2V, V _{IL} ≤ 0.2V	
Standby current	I _{SB}	—	0.1*6	0.3	mA	CS# = V _{IH} , Others = V _{SS} to V _{CC}	
Standby current	I _{SB1}	—	0.3*6	2	μA	~+25°C	V _{in} = V _{SS} to V _{CC} , CS# ≥ V _{CC} -0.2V
		—	—	3	μA	~+40°C	
		—	—	5	μA	~+70°C	
		—	—	7	μA	~+85°C	
Output high voltage	V _{OH}	2.4	—	—	V	I _{OH} = -1mA	
	V _{OH2}	V _{CC} -0.2	—	—	V	I _{OH} = -0.1mA	
Output low voltage	V _{OL}	—	—	0.4	V	I _{OL} = 2.1mA	
	V _{OL2}	—	—	0.2	V	I _{OL} = 0.1mA	

Note 6. Typical parameter indicates the value for the center of distribution at 3.0V (T_a=25°C), and not 100% tested.

Capacitance

(V_{CC} = 2.7V ~ 3.6V, f = 1MHz, T_a = -40 ~ +85°C)

Parameter	Symbol	Min.	Typ.	Max.	Unit	Test conditions	Note
Input capacitance	C _{in}	—	—	8	pF	V _{in} = 0V	7
Input / output capacitance	C _{I/O}	—	—	10	pF	V _{I/O} = 0V	7

Note 7. This parameter is sampled and not 100% tested.

AC Characteristics

Test Conditions ($V_{CC} = 2.7V \sim 3.6V$, $T_a = -40 \sim +85^{\circ}C$)

- Input pulse levels: $V_{IL} = 0.4V$, $V_{IH} = 2.4V$
- Input rise and fall time: 5ns
- Input and output timing reference level: 1.4V
- Output load: See figures (Including scope and jig)

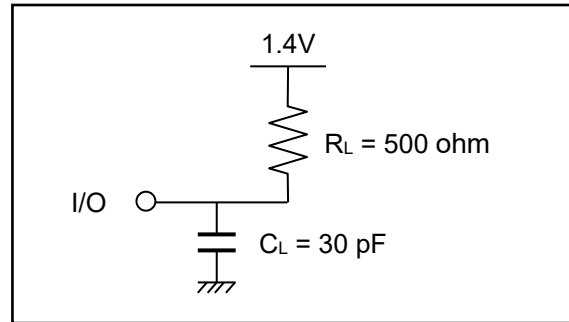

Read Cycle

Parameter	Symbol	Min.	Max.	Unit	Note
Read cycle time	t_{RC}	45	—	ns	
Address access time	t_{AA}	—	45	ns	
Chip select access time	t_{ACS}	—	45	ns	
Output enable to output valid	t_{OE}	—	22	ns	
Output hold from address change	t_{OH}	10	—	ns	
Chip select to output in low-Z	t_{CLZ}	10	—	ns	8,9
Output enable to output in low-Z	t_{OLZ}	5	—	ns	8,9
Chip deselect to output in high-Z	t_{CHZ}	0	18	ns	8,9,10
Output disable to output in high-Z	t_{OHZ}	0	18	ns	8,9,10

Write Cycle

Parameter	Symbol	Min.	Max.	Unit	Note
Write cycle time	t_{WC}	45	—	ns	
Address valid to write end	t_{AW}	35	—	ns	
Chip select to write end	t_{CW}	35	—	ns	
Write pulse width	t_{WP}	35	—	ns	11
Address setup time to write start	t_{AS}	0	—	ns	
Write recovery time from write end	t_{WR}	0	—	ns	
Data to write time overlap	t_{DW}	25	—	ns	
Data hold from write end	t_{DH}	0	—	ns	
Output enable from write end	t_{OW}	5	—	ns	8
Output disable to output in high-Z	t_{OHZ}	0	18	ns	8,10
Write to output in high-Z	t_{WHZ}	0	18	ns	8,10

Note 8. This parameter is sampled and not 100% tested.

9. At any given temperature and voltage condition, t_{CHZ} max is less than t_{CLZ} min, and t_{OHZ} max is less than t_{OLZ} min, for any device.

10. t_{CHZ} , t_{OHZ} and t_{WHZ} are defined as the time when the I/O pins enter a high-impedance state and are not referred to the I/O levels.

11. t_{WP} is the interval between write start and write end.

A write starts when both of CS# and WE# become active

A write is performed during the overlap of a low CS#, a low WE#

A write ends when any of CS#, WE# becomes inactive.

Timing Waveforms

Read Cycle

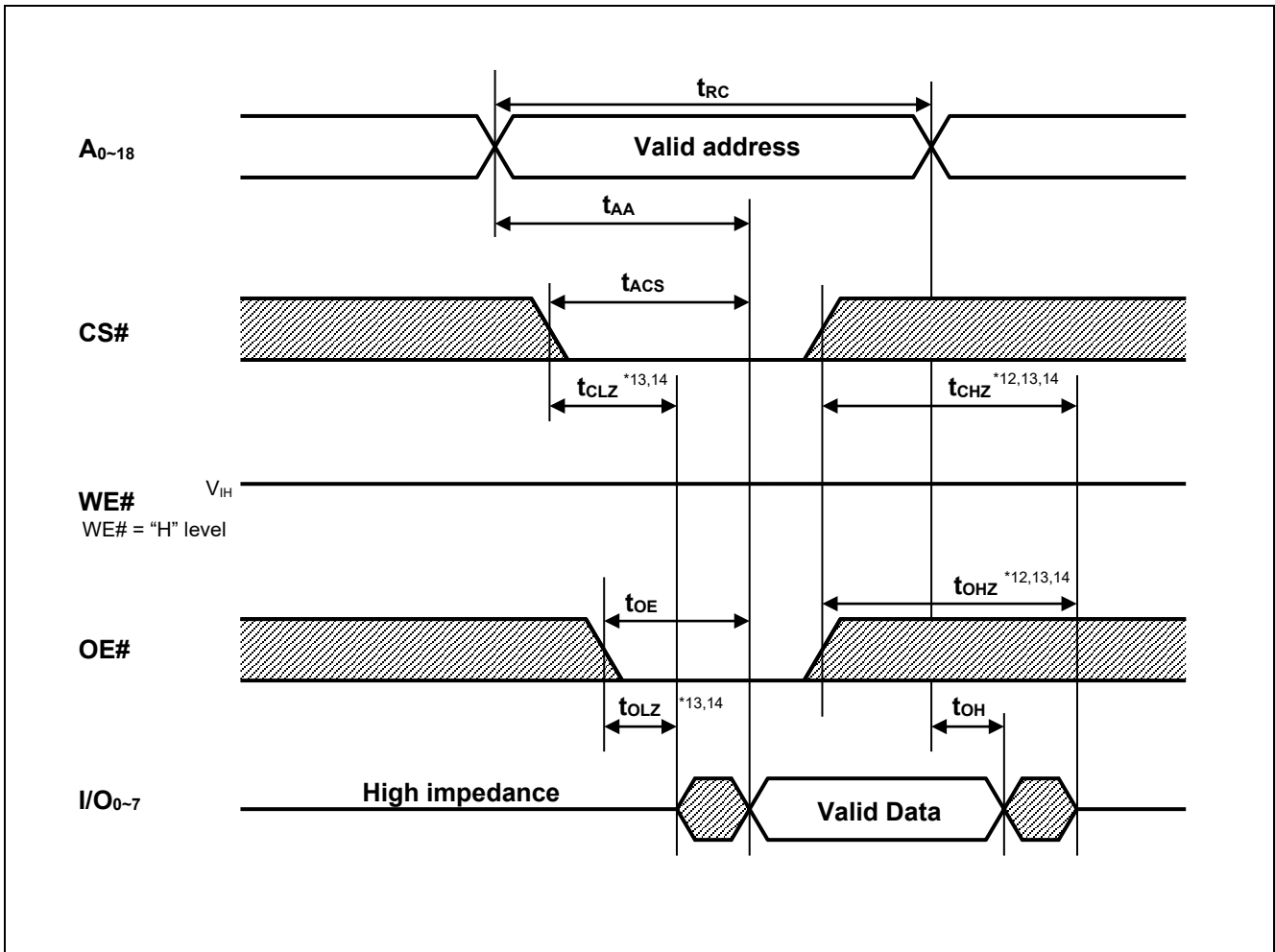

- Note 12. t_{CHZ} and t_{OHZ} are defined as the time when the I/O pins enter a high-impedance state and are not referred to the I/O levels.
13. This parameter is sampled and not 100% tested.
14. At any given temperature and voltage condition, t_{CHZ} max is less than t_{CLZ} min, and t_{OHZ} max is less than t_{OLZ} min, for any device.

Write Cycle (1) (WE# CLOCK, OE#="H" while writing)

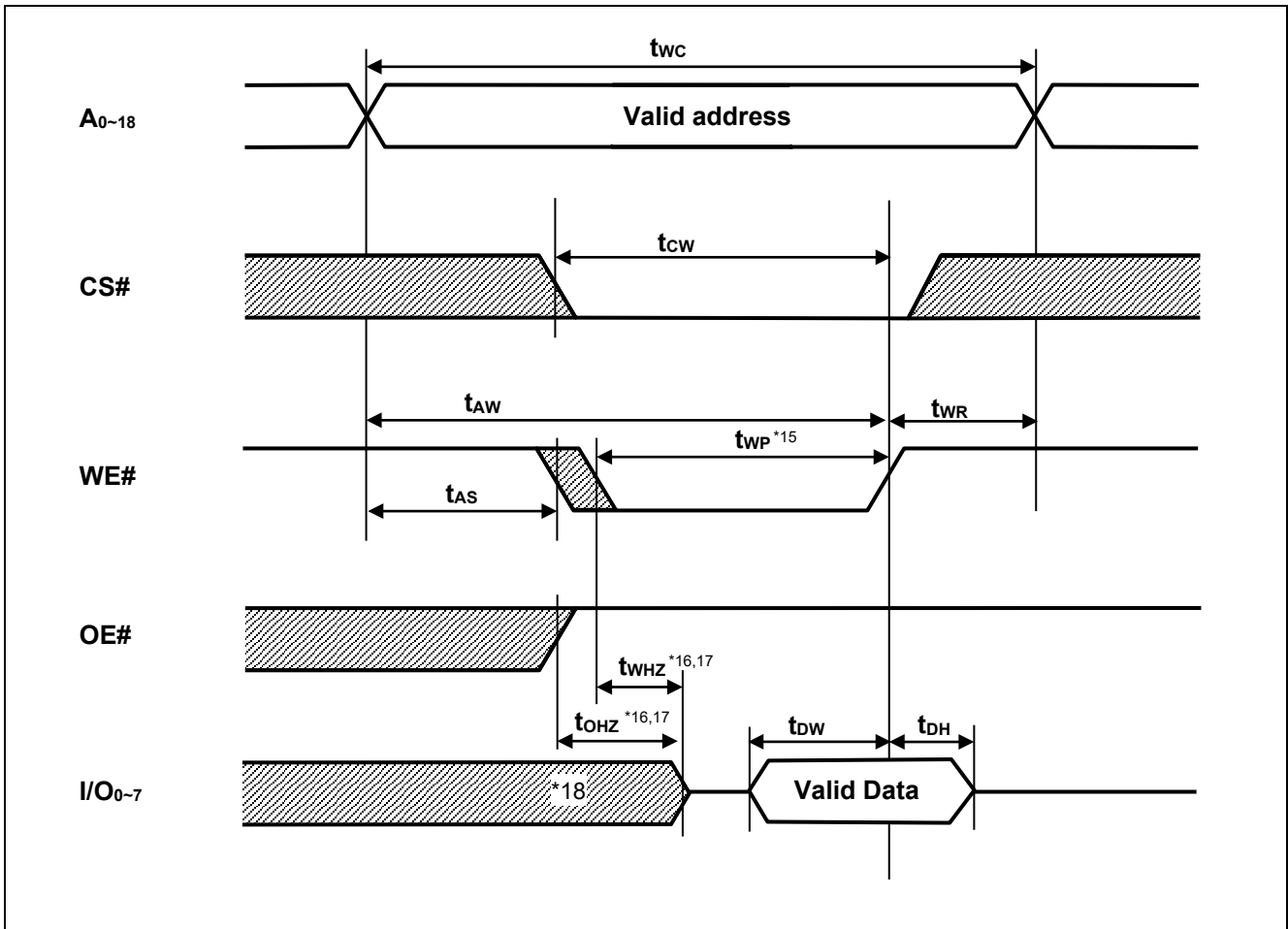

- Note 15. t_{wp} is the interval between write start and write end.
 A write starts when both of CS# and WE# become active.
 A write is performed during the overlap of a low CS# and a low WE#.
 A write ends when any of CS# or WE# becomes inactive.
16. t_{ohz} and t_{whz} are defined as the time when the I/O pins enter a high-impedance state and are not referred to the I/O levels.
17. This parameter is sampled and not 100% tested.
18. During this period, I/O pins are in the output state so input signals must not be applied to the I/O pins.

Write Cycle (2) (WE# CLOCK, OE# Low Fixed)

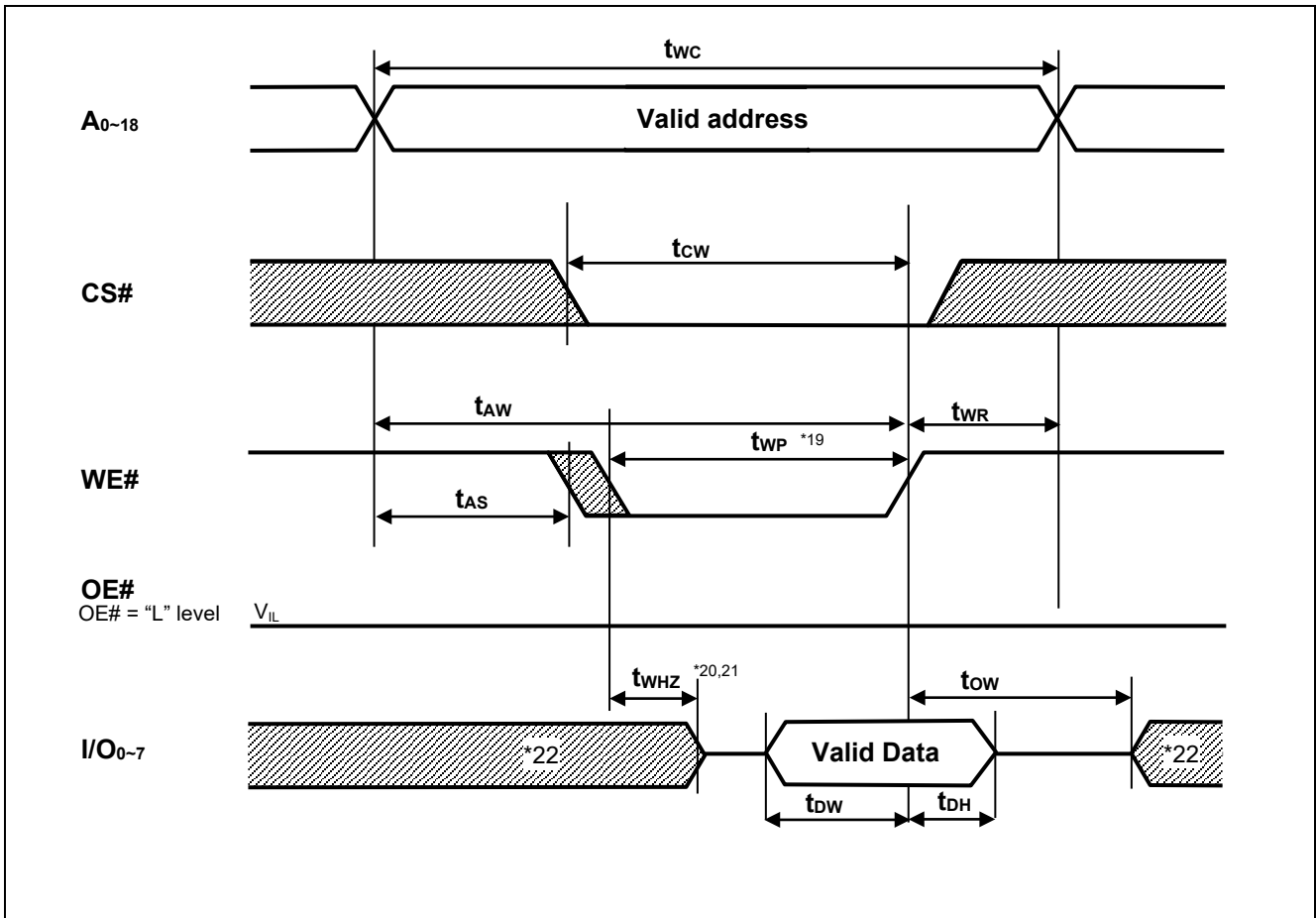

- Note 19. t_{WP} is the interval between write start and write end.
 A write starts when both of CS# and WE# become active.
 A write is performed during the overlap of a low CS# and a low WE#.
 A write ends when any of CS# or WE# becomes inactive.
20. t_{WHZ} is defined as the time when the I/O pins enter a high-impedance state and are not referred to the I/O levels.
21. This parameter is sampled and not 100% tested.
22. During this period, I/O pins are in the output state so input signals must not be applied to the I/O pins.

Write Cycle (3) (CS# CLOCK)

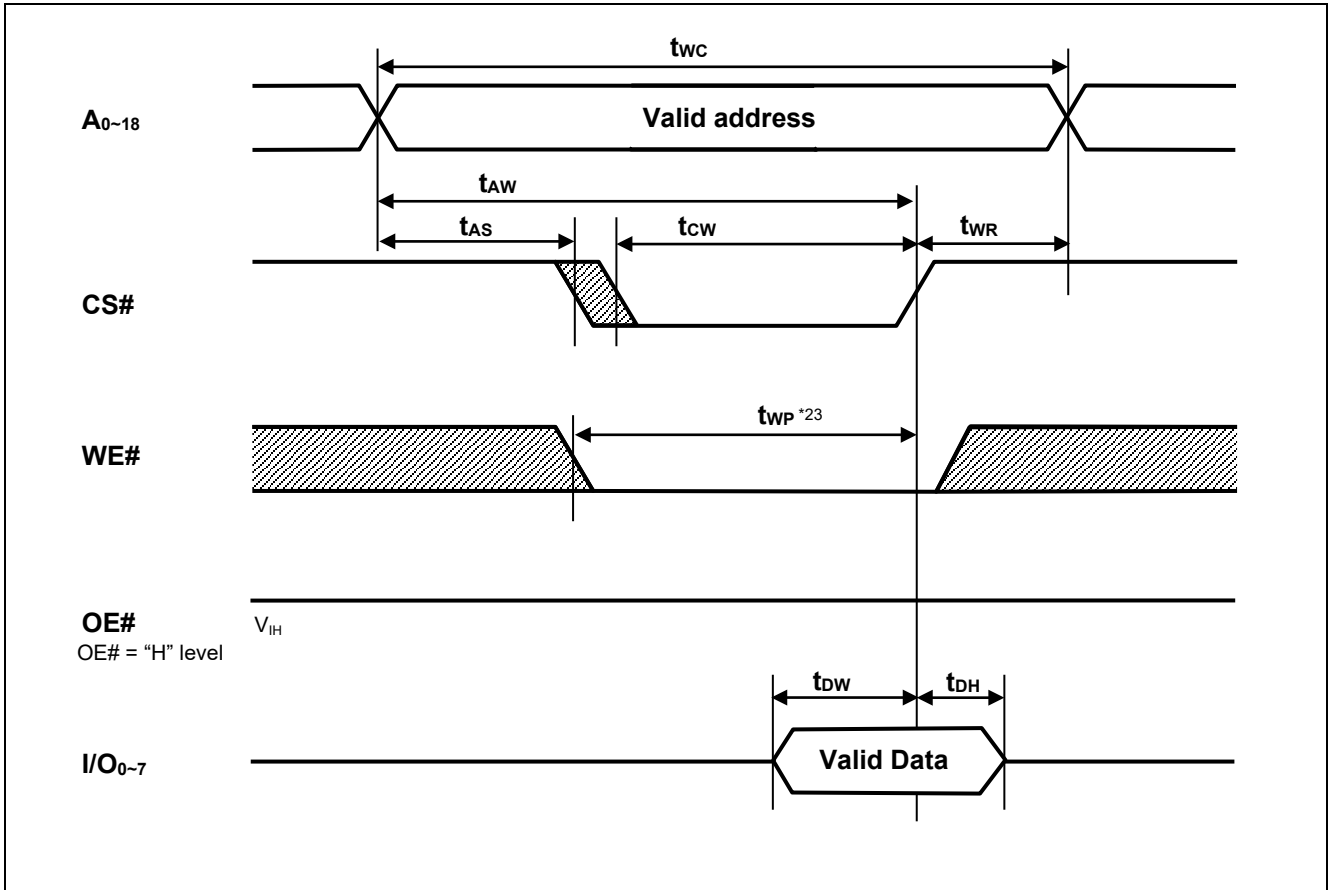

Note 23. t_{WP} is the interval between write start and write end.
 A write starts when both of CS# and WE# become active.
 A write is performed during the overlap of a low CS# and a low WE#.
 A write ends when any of CS# or WE# becomes inactive.

Low V_{CC} Data Retention Characteristics

Parameter	Symbol	Min.	Typ.	Max.	Unit	Test conditions ^{*25}	
V _{CC} for data retention	V _{DR}	1.5	—	—	V	V _{in} ≥ 0V, CS# ≥ V _{CC} -0.2V	
Data retention current	I _{CCDR}	—	0.3 ^{*24}	2	μA	~+25°C	V _{CC} =3.0V, V _{in} ≥ 0V, CS# ≥ V _{CC} -0.2V
		—	—	3	μA	~+40°C	
		—	—	5	μA	~+70°C	
		—	—	7	μA	~+85°C	
Chip deselect time to data retention	t _{CDR}	0	—	—	ns	See retention waveform.	
Operation recovery time	t _R	5	—	—	ms		

Note 24. Typical parameter indicates the value for the center of distribution at 3.0V (T_a=25°C), and not 100% tested.

25. CS# controls address buffer, WE# buffer, OE# buffer, and I/O buffer. If CS# controls data retention mode, V_{in} levels (address, WE#, OE#, I/O) can be in the high-impedance state.

Low V_{CC} Data Retention Timing Waveforms (CS# controlled)

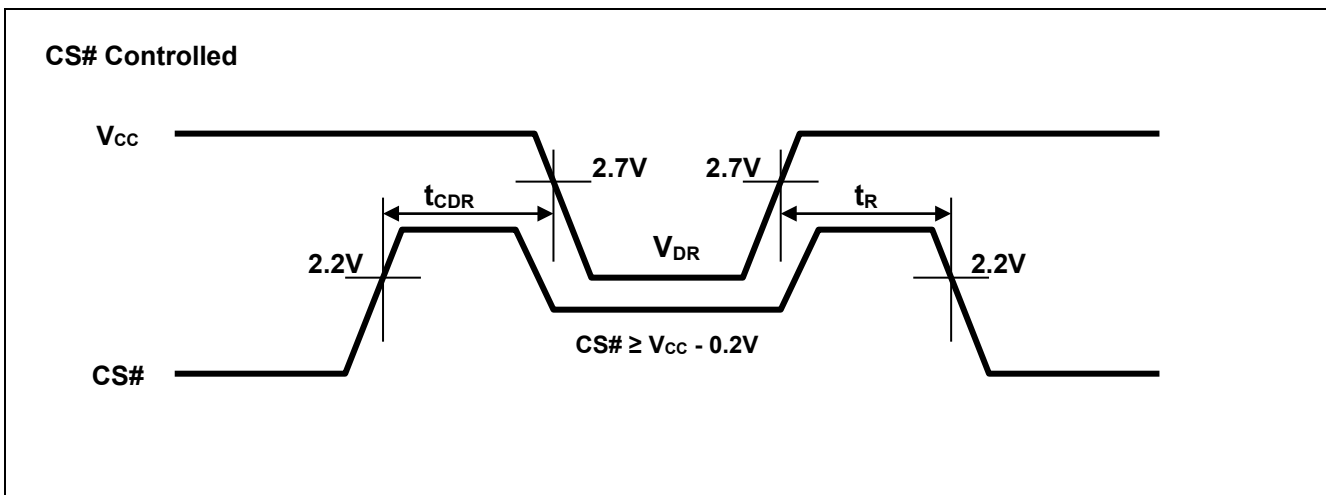

Revision History	RMLV0408E Series Data Sheet
------------------	-----------------------------

Rev.	Date	Description	
		Page	Summary
1.00	2014.2.27	—	First edition issued
2.00	2016.1.12	1	Changed section from “Part Name Information” to “Orderable part number information”
2.01	2020.2.20	Last page	Updated the Notice to the latest version
3.00	2021.8.18	1,4,10	Changed the typical value of I_{SB1} and I_{CCDR} from $0.4\mu A$ to $0.3\mu A$. Revised orderable part number information

IMPORTANT NOTICE AND DISCLAIMER

RENESAS ELECTRONICS CORPORATION AND ITS SUBSIDIARIES (“RENESAS”) PROVIDES TECHNICAL SPECIFICATIONS AND RELIABILITY DATA (INCLUDING DATASHEETS), DESIGN RESOURCES (INCLUDING REFERENCE DESIGNS), APPLICATION OR OTHER DESIGN ADVICE, WEB TOOLS, SAFETY INFORMATION, AND OTHER RESOURCES “AS IS” AND WITH ALL FAULTS, AND DISCLAIMS ALL WARRANTIES, EXPRESS OR IMPLIED, INCLUDING, WITHOUT LIMITATION, ANY IMPLIED WARRANTIES OF MERCHANTABILITY, FITNESS FOR A PARTICULAR PURPOSE, OR NON-INFRINGEMENT OF THIRD PARTY INTELLECTUAL PROPERTY RIGHTS.

These resources are intended for developers skilled in the art designing with Renesas products. You are solely responsible for (1) selecting the appropriate products for your application, (2) designing, validating, and testing your application, and (3) ensuring your application meets applicable standards, and any other safety, security, or other requirements. These resources are subject to change without notice. Renesas grants you permission to use these resources only for development of an application that uses Renesas products. Other reproduction or use of these resources is strictly prohibited. No license is granted to any other Renesas intellectual property or to any third party intellectual property. Renesas disclaims responsibility for, and you will fully indemnify Renesas and its representatives against, any claims, damages, costs, losses, or liabilities arising out of your use of these resources. Renesas' products are provided only subject to Renesas' Terms and Conditions of Sale or other applicable terms agreed to in writing. No use of any Renesas resources expands or otherwise alters any applicable warranties or warranty disclaimers for these products.

(Rev.1.0 Mar 2020)

Corporate Headquarters

TOYOSU FORESIA, 3-2-24 Toyosu,
Koto-ku, Tokyo 135-0061, Japan
www.renesas.com

Contact Information

For further information on a product, technology, the most up-to-date version of a document, or your nearest sales office, please visit:
www.renesas.com/contact/

Trademarks

Renesas and the Renesas logo are trademarks of Renesas Electronics Corporation. All trademarks and registered trademarks are the property of their respective owners.

X-ON Electronics

Largest Supplier of Electrical and Electronic Components

Click to view similar products for [EEPROM](#) category:

Click to view products by [Renesas](#) manufacturer:

Other Similar products are found below :

[M29F040-70K6](#) [718278CB](#) [718620G](#) [444358RB](#) [444362FB](#) [BR93C46-WMN7TP](#) [EEROMH](#) [CAT25320YIGT-KK](#) [LE24C162-R-E](#) [5962-8751409YA](#) [BR9016AF-WE2](#) [LE2464DXATBG](#) [CAS93C66VP2I-GT3](#) [W60002FT20T](#) [CAT24S128C4UTR](#) [ZD24C64B-SSGMA0](#) [BL24C04F-RRRC](#) [S-25C040A0I-I8T1U](#) [AT24C256BY7-YH-T](#) [M24C64-DFCT6TPK](#) [BR24C21FJ-E2](#) [BR24G02FVJ-3GTE2](#) [BR24L16FJ-WE2](#) [BR24L16FVJ-WE2](#) [BR24S16FJ-WE2](#) [BR24S256F-WE2](#) [BR93L56RFV-WE2](#) [BR93L66F-WE2](#) [BR93L76RFV-WE2](#) [CAT24C64C4CTR](#) [CHL24C32WEGT3](#) [AT28HC256E-12SU-T](#) [AT93C46DY6-YH-T](#) [BR24T02FVT-WSGE2](#) [M35B32-WMN6TP](#) [M24C64-FMC6TG](#) [M24C08-WDW6TP](#) [CAT25080VP2IGTQH](#) [CAT25020ZIGT-QP](#) [CAT24C01VP2I-GT3](#) [CAT93C76BZI-GT3](#) [CAT64LC40WI-T3](#) [CAT25256HU4E-GT3](#) [CAT25128VP2I-GT3](#) [CAT25040VP2I-GT3](#) [CAT25020VP2I-GT3](#) [CAT24C16ZI-G](#) [CAT24C05LI-G](#) [CAT24C01ZI-G](#) [CAT24C05WI-G](#)