

240-MHz 32-bit RX MCU, on-chip double-precision FPU, 1396 CoreMark, Arithmetic unit for trigonometric functions, up to 4-MB flash memory (supportive of the dual bank function), 1-MB SRAM, various communications interfaces including Ethernet MAC compliant with IEEE 1588, SD host interface, quad SPI, and CAN, 12-bit A/D converter, RTC, Encryption functions (optional), Serial sound interface, CMOS camera interface, Graphic-LCD controller, 2D drawing engine

Features

■ 32-bit RXv3 CPU core

- Maximum operating frequency: 240 MHz
Capable of 1396 CoreMark in operation at 240 MHz
- Double-precision 64-bit IEEE-754 floating point
- A collective register bank save function is available.
- Supports the memory protection unit (MPU)
- JTAG and FINE (one-line) debugging interfaces

■ Low-power design and architecture

- Operation from a single 2.7- to 3.6-V supply
- RTC is capable of operation from a dedicated power supply.
- Four low-power modes

■ On-chip code flash memory

- Supports versions with up to 4 Mbytes of ROM
- No wait cycles at up to 120 MHz or when the ROM cache is hit, one-wait state at above 120 MHz
- User code is programmable by on-board or off-board programming.
- Programming/erasing as background operations (BGOs)
- A dual-bank structure allows exchanging the start-up bank.

■ On-chip data flash memory

- 32 Kbytes, reprogrammable up to 100,000 times
- Programming/erasing as background operations (BGOs)

■ On-chip SRAM

- 1 Mbyte of SRAM (no wait states; however, if ICLK is at a frequency above 120 MHz, access to locations in the 512 Kbytes of SRAM from 0080 0000h to 0087 FFFFh requires one cycle of waiting)
- 32 Kbytes of RAM with ECC (single error correction/double error detection)
- 8 Kbytes of standby RAM (backup on deep software standby)

■ Data transfer

- DMAcAa: 8 channels
- DTcB: 1 channel
- EXDMAc: 2 channels
- DMAC for the Ethernet controller: 3 channels

■ Reset and supply management

- Power-on reset (POR)
- Low voltage detection (LVD) with voltage settings

■ Clock functions

- External crystal resonator or internal PLL for operation at 8 to 24 MHz
- PLL for specific purposes
- Internal 240-kHz LOCO and HOCO selectable from 16, 18, and 20 MHz
- 120-kHz clock for the IWDTa

■ Real-time clock

- Adjustment functions (30 seconds, leap year, and error)
- Real-time clock counting and binary counting modes are selectable
- Time capture function
(for capturing times in response to event-signal input)

■ Independent watchdog timer

- 120-kHz clock operation

■ Useful functions for IEC60730 compliance

- Oscillation-stoppage detection, frequency measurement, CRCA, IWDTa, self-diagnostic function for the A/D converter, etc.
- Register write protection function can protect values in important registers against overwriting.

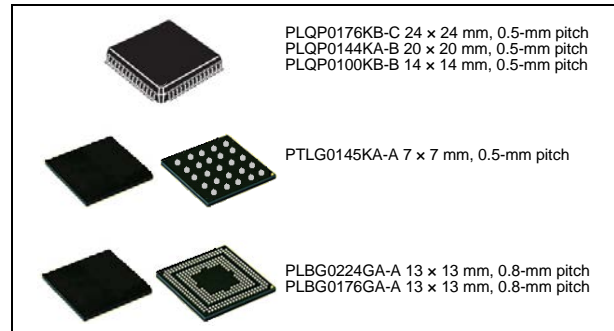

■ Various communications interfaces

- Ethernet MAC compliant with IEEE 1588 (2 channels)
- PHY layer (1 channel) for host/function or OTG controller (1 channel) with full-speed USB 2.0 transfer
- CAN (compliant with ISO11898-1), incorporating 32 mailboxes (up to 3 channels)
- SCIj and SCIl with multiple functionalities (up to 8 channels)
Choose from among asynchronous mode, clock-synchronous mode, smart-card interface mode, simplified SPI, simplified I²C, and extended serial mode.
- SCIl with 16-byte transmission and reception FIFOs (up to 5 channels)
- I²C bus interface for transfer at up to 1 Mbps (3 channels)
- Four-wire QSPI (1 channel) in addition to RSPIC (3 channels)
- Parallel data capture unit (PDC) for the CMOS camera interface (except for 100-pin products)
- Graphic-LCD controller (GLCDC)
- 2D drawing engine (DRW2D)
- SD host interface (1 channel) with a 1- or 4-bit SD bus for use with SD memory or SDIO
- MMCIF with 1-, 4-, or 8-bit transfer bus width

■ External address space

- Buses for full-speed data transfer (max. operating frequency of 80 MHz)
- 8 CS areas
- 8-, 16-, or 32-bit bus space is selectable per area
- Independent SDRAM area (128 Mbytes)

■ Up to 29 extended-function timers

- 32-bit GPTW (4 channels)
- 16-bit TPUa (6 channels), MTU3a (9 channels)
- 8-bit TMRa (4 channels), 16-bit CMT (4 channels), 32-bit CMTW (2 channels)

■ 12-bit A/D converter

- Two 12-bit units (8 channels for unit 0; 21 channels for unit 1)
- Self diagnosis, detection of analog input disconnection

■ 12-bit D/A converter: 2 channels

■ Temperature sensor for measuring temperature within the chip

■ Arithmetic unit for trigonometric functions

■ Encryption functions (optional)

- AES (key lengths: 128, 192, and 256 bits)
- Trusted Secure IP (TSIP)

■ Up to 182 pins for general I/O ports

- 5-V tolerance, open drain, input pull-up, switchable driving ability

■ Operating temp. range

- D-version: -40°C to +85°C
- G-version: -40°C to +105°C

1. Overview

1.1 Outline of Specifications

Table 1.1 lists the specifications in outline, and Table 1.2 give a comparison of the functions of products in different packages.

Table 1.1 is an outline of maximum specifications, and the peripheral modules and the number of channels of the modules differ depending on the number of pins on the package and the capacity of the code flash memory. For details, refer to Table 1.2, Comparison of Functions for Different Packages.

Table 1.1 Outline of Specifications (1/11)

Classification	Module/Function	Description
CPU	CPU	<ul style="list-style-type: none"> • Maximum operating frequency: 240 MHz • 32-bit RX CPU (RXv3) • Minimum instruction execution time: One instruction per state (cycle of the system clock) • Address space: 4-Gbyte linear • Register set of the CPU <ul style="list-style-type: none"> General purpose: Sixteen 32-bit registers Control: Ten 32-bit registers Accumulator: Two 72-bit registers • 113 instructions <ul style="list-style-type: none"> Instructions installed as standard: 111 Basic instructions: 77 Single-precision floating-point operation instructions: 11 DSP instructions: 23 Instructions for register bank save function: 2 • Addressing modes: 11 • Data arrangement <ul style="list-style-type: none"> Instructions: Little endian Data: Selectable as little endian or big endian • On-chip 32-bit multiplier: $32 \times 32 \rightarrow 64$ bits • On-chip divider: $32 / 32 \rightarrow 32$ bits • Barrel shifter: 32 bits
	FPU	<ul style="list-style-type: none"> • Single-precision floating-point numbers (32 bits) and double-precision floating-point numbers (64 bits) • Data types and floating-point exceptions in conformance with the IEEE754 standard
	Double-precision floating point coprocessor	<ul style="list-style-type: none"> • Double-precision floating-point register set <ul style="list-style-type: none"> Double-precision floating-point data registers: 16, each with 64-bit width Double-precision floating-point control registers: Four, each with 32-bit width • Double-precision floating-point processing instructions: 21 • Notifying the interrupt controller of double-precision floating-point exceptions
	Register bank save function	<ul style="list-style-type: none"> • Fast collective saving and restoration of the values of CPU registers • 16 save register banks

Table 1.1 Outline of Specifications (2/11)

Classification	Module/Function	Description
Memory	Code flash memory	<ul style="list-style-type: none"> Capacity: 2 Mbytes/4 Mbytes ROM cache: 8 Kbytes 120 MHz ≤ No-wait cycle access, 120 MHz > One-wait cycle access Instructions hitting the ROM cache or operand = 240 MHz: No-wait access On-board programming: Four types Off-board programming (parallel programmer mode) Instructions are executable only for the program stored in the TM target area by using the Trusted Memory (TM) function and protection against data reading is realized. A dual-bank structure allows programming during reading or exchanging the start-up areas
	Data flash memory	<ul style="list-style-type: none"> Capacity: 32 Kbytes Programming/erasing: 100,000 times
	Unique ID	<ul style="list-style-type: none"> 16-byte unique ID for each device
	RAM	<ul style="list-style-type: none"> Capacity: 512 Kbytes Up to 240 MHz, no-wait access
	Expansion RAM	<ul style="list-style-type: none"> Capacity: 512 Kbytes 120 MHz ≤ No-wait cycle access, 120 MHz > One-wait cycle access
	ECC RAM	<ul style="list-style-type: none"> Capacity: 32 Kbytes If the operating frequency is no greater than 120 MHz, one-wait cycle access, if greater than 120MHz, two-wait cycle access in the case of reading, and three-wait cycle access in the case of writing SEC-DED (single-bit error correction and double-bit error detection)
	Standby RAM	<ul style="list-style-type: none"> Capacity: 8 Kbytes Operation synchronized with PCLKB: Up to 60 MHz, two-cycle access
Operating modes		<ul style="list-style-type: none"> Operating modes by the mode-setting pins at the time of release from the reset state <ul style="list-style-type: none"> Single-chip mode Boot mode (for the SCI interface) Boot mode (for the USB interface) Boot mode (for the FINE interface) Selection of operating mode by register setting <ul style="list-style-type: none"> Single-chip mode On-chip ROM disabled extended mode On-chip ROM enabled extended mode Endian selectable
Clock	Clock generation circuit	<ul style="list-style-type: none"> Main clock oscillator, sub-clock oscillator, low-speed/high-speed on-chip oscillator, PLL frequency synthesizer (two circuits), and IWDG-dedicated on-chip oscillator The peripheral module clocks can be set to frequencies above that of the system clock. Main-clock oscillation stoppage detection Separate frequency-division and multiplication settings for the system clock (ICKL), peripheral module clocks (PCLKA, PCLKB, PCLKC, PCLKD), flash-IF clock (FCLK) and external bus clock (BCLK) The CPU and other bus masters run in synchronization with the system clock (ICKL): Up to 240 MHz Peripheral modules of MTU, RSPI, SCi, ETHERC, EPTPC, PMGI, EDMAC, GPTW, GLCDC, and DRW2D, run in synchronization with PCLKA, which operates at up to 120 MHz. Other peripheral modules run in synchronization with PCLKB: Up to 60 MHz ADCLK in the S12AD (unit 0) runs in synchronization with PCLKC: Up to 60 MHz ADCLK in the S12AD (unit 1) runs in synchronization with PCLKD: Up to 60 MHz Flash IF run in synchronization with the flash-IF clock (FCLK): Up to 60 MHz Devices connected to the external bus run in synchronization with the external bus clock (BCLK): Up to 80 MHz The high-speed on-chip oscillator (HOCO) can be obtained through frequency-multiplication of the PLL or PPLL reference clock External clock input frequency: 30 MHz (max) Clock output function

Table 1.1 Outline of Specifications (3/11)

Classification	Module/Function	Description
Reset		<p>Nine types of reset</p> <ul style="list-style-type: none"> • RES# pin reset: Generated when the RES# pin is driven low. • Power-on reset: Generated when the RES# pin is driven high and VCC = AVCC0 = AVCC1 rises. • Voltage-monitoring 0 reset: Generated when VCC = AVCC0 = AVCC1 falls. • Voltage-monitoring 1 reset: Generated when VCC = AVCC0 = AVCC1 falls. • Voltage-monitoring 2 reset: Generated when VCC = AVCC0 = AVCC1 falls. • Deep software standby reset: Generated in response to an interrupt to trigger release from deep software standby. • Independent watchdog timer reset: Generated when the independent watchdog timer underflows, or a refresh error occurs. • Watchdog timer reset: Generated when the watchdog timer underflows, or a refresh error occurs. • Software reset: Generated by register setting.
Power-on reset		<ul style="list-style-type: none"> • If the RES# pin is at the high level when power is supplied, an internal reset is generated. After VCC = AVCC0 = AVCC1 has exceeded the voltage detection level and the specified period has elapsed, the reset is cancelled.
Voltage detection circuit (LVDA)		<p>Monitors the voltage being input to the VCC = AVCC0 = AVCC1 pins and generates an internal reset or interrupt.</p> <ul style="list-style-type: none"> • Voltage detection circuit 0 <ul style="list-style-type: none"> Capable of generating an internal reset The option-setting memory can be used to select enabling or disabling of the reset. Voltage detection level: Selectable from three different levels (2.94 V, 2.87 V, 2.80 V) • Voltage detection circuits 1 and 2 <ul style="list-style-type: none"> Voltage detection level: Selectable from three different levels (2.99 V, 2.92 V, 2.85 V) Digital filtering (1/2, 1/4, 1/8, and 1/16 LOCO frequency) Capable of generating an internal reset • Two types of timing are selectable for release from reset An internal interrupt can be requested. • Detection of voltage rising above and falling below thresholds is selectable. • Maskable or non-maskable interrupt is selectable Voltage detection monitoring Event linking
Low power consumption	Low power consumption function	<ul style="list-style-type: none"> • Module stop function • Four low power consumption modes Sleep mode, all-module clock stop mode, software standby mode, and deep software standby mode
	Battery backup function	<ul style="list-style-type: none"> • When the voltage on the VCC pin drops, battery power from the VBATT pin is supplied to keep the real-time clock (RTC) operating.
Interrupt	Interrupt controller (ICUD)	<ul style="list-style-type: none"> • Number of interrupt vectors: 256 • External interrupts: 16 (pins IRQ0 to IRQ15) • Software interrupts: 2 sources • Non-maskable interrupts: 8 sources • Sixteen levels specifiable for the order of priority • Method of interrupt source selection: <ul style="list-style-type: none"> The interrupt vectors consist of 256 vectors (128 sources are fixed. The remaining 128 vectors are selected from among the other 163 sources.)
External bus extension		<ul style="list-style-type: none"> • The external address space can be divided into eight areas (CS0 to CS7), each with independent control of access settings. Capacity of each area: 16 Mbytes (CS0 to CS7) A chip-select signal (CS0# to CS7#) can be output for each area. Each area is specifiable as an 8-, 16-, or 32-bit bus space. The data arrangement in each area is selectable as little or big endian (only for data). • SDRAM interface connectable • Bus format: Separate bus, multiplex bus • Wait control • Write buffer facility

Table 1.1 Outline of Specifications (4/11)

Classification	Module/Function	Description
DMA	DMA controller (DMACa)	<ul style="list-style-type: none"> • 8 channels • Three transfer modes: Normal transfer, repeat transfer, and block transfer • Activation sources: Software trigger and interrupt requests from peripheral functions
	EXDMA controller (EXDMACa)	<ul style="list-style-type: none"> • 2 channels • Four transfer modes: Normal transfer, repeat transfer, block transfer, and cluster transfer • Single-address transfer enabled with the EDACKn signal • Request sources: Software trigger, external DMA requests (EDREQn), and interrupt requests from peripheral functions
	Data transfer controller (DTCb)	<ul style="list-style-type: none"> • Three transfer modes: Normal transfer, repeat transfer, and block transfer • Request sources: External interrupts and interrupt requests from peripheral functions • Sequence transfer
I/O ports	Programmable I/O ports	<ul style="list-style-type: none"> • I/O ports for the 224-pin LFBGA I/O pins: 182 Input pin: 1 Pull-up resistors: 182 Open-drain outputs: 182 5-V tolerance: 19 • I/O ports for the 176-pin LFBGA and 176-pin LFQFP I/O pins: 136 Input pin: 1 Pull-up resistors: 136 Open-drain outputs: 136 5-V tolerance: 19 • I/O ports for the 145-pin TFLGA and 144-pin LFQFP I/O pins: 111 Input pin: 1 Pull-up resistors: 111 Open-drain outputs: 111 5-V tolerance: 18 • I/O ports for the 100-pin LFQFP I/O pins: 78 Input pin: 1 Pull-up resistors: 78 Open-drain outputs: 78 5-V tolerance: 17
Event link controller (ELC)		<ul style="list-style-type: none"> • Event signals such as interrupt request signals can be interlinked with the operation of functions such as timer counting, eliminating the need for intervention by the CPU to control the functions. • 135 internal event signals can be freely combined for interlinked operation with connected functions. • Event signals from peripheral modules can be used to change the states of output pins (of ports B and E). • Changes in the states of pins (of ports B and E) being used as inputs can be interlinked with the operation of peripheral modules.

Table 1.1 Outline of Specifications (5/11)

Classification	Module/Function	Description
Timers	16-bit timer pulse unit (TPUa)	<ul style="list-style-type: none"> • (16 bits × 6 channels) × 1 unit • Maximum of 16 pulse-input/output possible • Select from among seven or eight counter-input clock signals for each channel • Input capture/output compare function • Output of PWM waveforms in up to 15 phases in PWM mode • Support for buffered operation, phase-counting mode (two phase encoder input) and cascade-connected operation (32 bits × 2 channels) depending on the channel. • PPG output trigger can be generated • Capable of generating conversion start triggers for the A/D converters • Digital filtering of signals from the input capture pins • Event linking by the ELC
	Multifunction timer pulse unit (MTU3a)	<ul style="list-style-type: none"> • 9 channels (16 bits × 8 channels, 32 bits × 1 channel) • Maximum of 28 pulse-input/output and 3 pulse-input possible • Select from among 14 counter-input clock signals for each channel (PCLKA/1, PCLKA/2, PCLKA/4, PCLKA/8, PCLKA/16, PCLKA/32, PCLKA/64, PCLKA/256, PCLKA/1024, MTCLKA, MTCLKB, MTCLKC, MTCLKD, MTIOC1A) 14 of the signals are available for channel 0, 11 are available for channels 1, 3, 4, 6 to 8, 12 are available for channel 2, and 10 are available for channel 5. • Input capture function • 39 output compare/input capture registers • Counter clear operation (synchronous clearing by compare match/input capture) • Simultaneous writing to multiple timer counters (TCNT) • Simultaneous register input/output by synchronous counter operation • Buffered operation • Support for cascade-connected operation • 43 interrupt sources • Automatic transfer of register data • Pulse output mode Toggle/PWM/complementary PWM/reset-synchronized PWM • Complementary PWM output mode Outputs non-overlapping waveforms for controlling 3-phase inverters Automatic specification of dead times PWM duty cycle: Selectable as any value from 0% to 100% Delay can be applied to requests for A/D conversion. Non-generation of interrupt requests at peak or trough values of counters can be selected. Double buffer configuration • Reset synchronous PWM mode Three phases of positive and negative PWM waveforms can be output with desired duty cycles. • Phase-counting mode: 16-bit mode (channels 1 and 2); 32-bit mode (channels 1 and 2) • Counter functionality for dead-time compensation • Generation of triggers for A/D converter conversion • A/D converter start triggers can be skipped • Digital filter function for signals on the input capture and external counter clock pins • PPG output trigger can be generated • Event linking by the ELC
	Port output enable 3 (POE3a)	<ul style="list-style-type: none"> • Control of the high-impedance state of the MTU waveform output pins • 5 pins for input from signal sources: POE0#, POE4#, POE8#, POE10#, POE11# • Initiation on detection of short-circuited outputs (detection of simultaneous PWM output to the active level) • Initiation by oscillation-stoppage detection or software • Additional programming of output control target pins is enabled

Table 1.1 Outline of Specifications (6/11)

Classification	Module/Function	Description
Timers	General PWM timer (GPTW)	<ul style="list-style-type: none"> • 32 bits × 4 channels (GPTW0 to GPTW3) • Counting up or down (sawtooth-wave), counting up and down (triangle-wave) selectable for all channels • Clock sources independently selectable for each channel • 2 input/output pins per channel • 2 output compare/input capture registers per channel • For the 2 output compare/input capture registers of each channel, 4 registers are provided as buffer registers and are capable of operating as comparison registers when buffering is not in use. • In output compare operation, buffer switching can be at crests or troughs, enabling the generation of laterally asymmetrically PWM waveforms. • Registers for setting up frame intervals on each channel (with capability for generating interrupts on overflow or underflow) • Generation of dead times in PWM operation • Capable of synchronous start, stop, or clearing of counter for any channel • Capable of a start, stop, clearing, or up-/down-counting of the counter supporting input level comparison • Capable of a start, stop, clearing, or up-/down-counting of the counter supporting maximum of 4 external triggers • Output pin disabling function by a dead time error or a short circuit detection among output pins • Capable of generating conversion start triggers for the A/D converters as well as monitoring external pins for a start timing of conversion. • Capable of outputting events, such as compare-match from A to F and overflow/underflow, to ELC • Capable of using noise filter of input capture
	Port output enable for GPTW (POEG)	<ul style="list-style-type: none"> • Controlling the output disable for GPTW waveform output • Initiation by input level detection of GTETRQ pins • Initiation by output disable request from GPTW • Initiation by detection of oscillation stop or by software
	Programmable pulse generator (PPG)	<ul style="list-style-type: none"> • (4 bits × 4 groups) × 2 units • Pulse output with the MTU or TPU output as a trigger • Maximum of 32 pulse-output possible
	8-bit timers (TMR)	<ul style="list-style-type: none"> • (8 bits × 2 channels) × 2 units • Select from among seven internal clock signals (PCLKB/1, PCLKB/2, PCLKB/8, PCLKB/32, PCLKB/64, PCLKB/1024, PCLKB/8192) and one external clock signal • Capable of output of pulse trains with desired duty cycles or of PWM signals • The 2 channels of each unit can be cascaded to create a 16-bit timer • Generation of triggers for A/D converter conversion • Capable of generating baud-rate clocks for SCI5, SCI6, and SCI12 • Event linking by the ELC
	Compare match timer (CMT)	<ul style="list-style-type: none"> • (16 bits × 2 channels) × 2 units • Select from among four internal clock signals (PCLKB/8, PCLKB/32, PCLKB/128, PCLKB/512)
	Compare match timer W (CMTW)	<ul style="list-style-type: none"> • (32 bits × 1 channel) × 2 units • Compare-match, input-capture input, and output-comparison output are available. • Select from among four internal clock signals (PCLKB/8, PCLKB/32, PCLKB/128, PCLKB/512) • Interrupt requests can be output in response to compare-match, input-capture, and output-comparison events. • Event linking by the ELC
	Realtime clock (RTCd)*1	<ul style="list-style-type: none"> • Clock sources: Main clock, sub-clock • Selection of the 32-bit binary count in time count/second unit possible • Clock and calendar functions • Interrupt sources: Alarm interrupt, periodic interrupt, and carry interrupt • Battery backup operation • Time-capture facility for three values • Event linking by the ELC
	Watchdog timer (WDTA)	<ul style="list-style-type: none"> • 14 bits × 1 channel • Select from among 6 counter-input clock signals (PCLKB/4, PCLKB/64, PCLKB/128, PCLKB/512, PCLKB/2048, PCLKB/8192)

Table 1.1 Outline of Specifications (7/11)

Classification	Module/Function	Description
Timers	Independent watchdog timer (IWDTa)	<ul style="list-style-type: none"> • 14 bits × 1 channel • Counter-input clock: IWDT-dedicated on-chip oscillator • Dedicated clock/1, dedicated clock/16, dedicated clock/32, dedicated clock/64, dedicated clock/128, dedicated clock/256 • Window function: The positions where the window starts and ends are specifiable (the window defines the timing with which refreshing is enabled and disabled). • Event linking by the ELC
Communication function	Ethernet controller (ETHERC)	<ul style="list-style-type: none"> • 2 channels • Input and output of Ethernet/IEEE 802.3 frames • Transfer at 10 or 100 Mbps • Full- and half-duplex modes • MII (Media Independent Interface) and RMII (Reduced Media Independent Interface) as defined in IEEE 802.3u • Detection of Magic Packets™*2 or output of a "wake-on-LAN" signal (WOL) • Compliance with flow control as defined in IEEE 802.3x standards • Filtering of multicast frames is supported. • Frame data can be directly transferred between 2 channels by cut-through switching.
	PHY management interface (PMGI)	<ul style="list-style-type: none"> • 2 channels • This module is compliant with the MII (Media Independent Interface) as defined in the IEEE 802.3u standard. • Transmission and reception of management frames through PHY-LSI chips having an MII or RMII interface is supported. • Alleviates load on the CPU by shifting it to dedicated hardware • The timing of management data is adjustable. • Preambles can be deleted.
	PTP module for the ethernet controller (EPTPCb)	<ul style="list-style-type: none"> • In connection with the Ethernet controller (ETHERC), this module is compliant with the IEEE1588 standard. • Matching with time stamps can be used to trigger counting by the MTU and GPTW.
	DMA controller for ethernet controller (EDMACa)	<ul style="list-style-type: none"> • 3 channels (each EDMAc determines the order of priority by a round-robin algorithm) For ETHERC: 2 channels, for EPTPC: 1 channel • Alleviation of CPU load by the descriptor control method • Transmission FIFO: 2 Kbytes; Reception FIFO: 4 Kbytes
	USB 2.0 FS host/function module (USBb)	<ul style="list-style-type: none"> • Includes a UDC (USB Device Controller) and transceiver for USB 2.0 FS • One port • Compliance with the USB 2.0 specification • Transfer rate: Full speed (12 Mbps), low speed (1.5 Mbps) (host only) • Both self-power mode and bus-power mode are supported • OTG (On the Go) operation is possible (low-speed is not supported) • Incorporates 2 Kbytes of RAM as a transfer buffer • External pull-up and pull-down resistors are not required

Table 1.1 Outline of Specifications (8/11)

Classification	Module/Function	Description
Communication function	Serial communications interfaces (SClj, SCli, SClh)	<ul style="list-style-type: none"> • 13 channels (SClj: 7 channels + SCli: 5 channels + SClh: 1 channel) • SClj, SCli, SClh Serial communications modes: Asynchronous, clock synchronous, and smart-card interface Multi-processor function On-chip baud rate generator allows selection of the desired bit rate Choice of LSB-first or MSB-first transfer Start-bit detection: Level or edge detection is selectable. Simple I ² C Simple SPI 7- to 9-bit transfer mode Bit rate modulation Double-speed mode Detecting matches of data is supported (other than for SCli12) <ul style="list-style-type: none"> • SClj, SClh Average transfer rate clock can be input from TMR timers for SCi5, SCi6, and SCi12 Event linking by the ELC (only on channel 5) <ul style="list-style-type: none"> • SCih Supports the serial communications protocol, which contains the start frame and information frame Supports the LIN format <ul style="list-style-type: none"> • SCli Data can be transmitted or received in sequence by the 16-byte FIFO buffers of the transmission and reception unit
	I ² C bus interface (RIICa)	<ul style="list-style-type: none"> • 3 channels (only channel 0 can be used in fast-mode plus) Communication formats I ² C bus format/SMBus format Supports the multi-master Max. transfer rate: 1 Mbps (channel 0) <ul style="list-style-type: none"> • Event linking by the ELC
	CAN module (CAN)	<ul style="list-style-type: none"> • 3 channels • Compliance with the ISO11898-1 specification (standard frame and extended frame) • 32 mailboxes per channel
	Serial peripheral interface (RSPic)	<ul style="list-style-type: none"> • 3 channels • RSPi transfer facility Using the MOSI (master out, slave in), MISO (master in, slave out), SSL (slave select), and RSPCK (RSPi clock) signals enables serial transfer through SPI operation (four lines) or clock-synchronous operation (three lines) Capable of handling serial transfer as a master or slave <ul style="list-style-type: none"> • Data formats Switching between MSB first and LSB first The number of bits in each transfer can be changed to any number of bits from 8 to 16, or to 20, 24, or 32 bits. 128-bit buffers for transmission and reception Up to four frames can be transmitted or received in a single transfer operation (with each frame having up to 32 bits) Transit/receive data can be swapped in byte units <ul style="list-style-type: none"> • Buffered structure • Double buffers for both transmission and reception • RSPCK can be stopped with the receive buffer full for master reception. • Event linking by the ELC
	Quad serial peripheral interface (QSPI)	<ul style="list-style-type: none"> • 1 channel • Connectable with serial flash memory equipped with multiple input and output lines (i.e. for single, dual, or quad operation) • Programmable bit length and selectable active sense and phase of the clock signal • Sequential execution of transfer • LSB or MSB first is selectable

Table 1.1 Outline of Specifications (9/11)

Classification	Module/Function	Description
	Extended serial sound interface (SSIE)	<ul style="list-style-type: none"> • 2 channels • Full-duplex transmission (only for channel 0) • Various types of serial audio formatting are supported. • Master and slave operations are supported. • The bit-clock frequency is selectable from among 13 frequencies (1/1, 1/2, 1/4, 1/6, 1/8, 1/12, 1/16, 1/24, 1/32, 1/48, 1/64, 1/96, or 1/128). • Data formats with 8, 16, 18, 20, 22, 24, and 32 bits are supported. • 32-stage FIFO buffers for transmission and reception • Stopping or not stopping the SSILRCK signal on stopping of data transmission is selectable.
	SD host interface (SDHI)	<ul style="list-style-type: none"> • 1 channel • Transfer speed: Supports high-speed mode (25 MB/s) and default speed mode (12.5 MB/s) • One interface for SD memory and I/O cards (supporting 1- and 4-bit SD buses) • SD specifications Part 1: Physical Layer Specification Ver. 3.01 compliant (DDR not supported) Part E1: SDIO Specification Ver. 3.00 • Error checking: CRC7 for commands and CRC16 for data • Interrupt requests: Card access interrupt, SDIO access interrupt, card detection interrupt, interrupt of SD buffer access • DMA transfer requests: SD_BUF write and SD_BUF read • Support for card detection and write protection
	MMC host interface (MMCIF)	<ul style="list-style-type: none"> • 1 channel • Transfer speed: Data transfer mode (30 MB/s), backward compatible mode (25 MB/s) • Compliant with JEDEC STANDARD JESD84-A441 (DDR is not supported) • Interface for Multimedia Cards (MMCs) • Data buses: Support for 1-, 4-, and 8-bit MMC buses • Interrupt requests: Card detection interrupt, error/timeout interrupt, normal operation interrupt, interrupt of MMCIF buffer access • DMA transfer requests: CE_DATA write and CE_DATA read • Support for card detection, boot operation, high priority interrupt (HPI)
	The arithmetic unit for trigonometric functions (TFU)	<ul style="list-style-type: none"> • Sine, cosine, arctangent, $\sqrt{x^2 + y^2}$ • Simultaneous calculation of sine and cosine • Simultaneous calculation of arctangent and $\sqrt{x^2 + y^2}$
	Parallel data capture unit (PDC)	<ul style="list-style-type: none"> • 1 channel • Acquisition of synchronization through external 8-bit horizontal and vertical synchronization signals • Setting of the image size when clipping of the output for a one-frame image is required
	Graphic-LCD controller (GLCDC)	<ul style="list-style-type: none"> • 1 channel • Various data formats and LCD panels are supported • Superposition of 3 planes (single-color background, graphic 1, graphic 2) • 32- and 16-bpp graphics data and 8-, 4-, and 1-bit CLUT data formats are supported
	2D drawing engine (DRW2D)	<ul style="list-style-type: none"> • 1 channel • Vector drawing (straight lines, triangles, and circles) • Bit blitting (with support for filling, copying, stretching, and rotation) • Bus master function for input and output of frame buffer data 32-, 16-, and 8-bit pixel graphics data are supported • Bus master function for input of texture data Input of texture data (32, 24, 16, 8, 4, 2, or 1 bit) are supported. Run length encoding is supported A CLUT is installed and index data can be converted into color data • Two rendering modes are supported (register mode and display list mode) • Performance counting • Interrupts in response to completion of rendering and processing of the display list

Table 1.1 Outline of Specifications (10/11)

Classification	Module/Function	Description
12-bit A/D converter (S12ADFa)		<ul style="list-style-type: none"> • 12 bits × 2 units (unit 0: 8 channels; unit 1: 21 channels) • 12-bit resolution (switchable between 8, 10, and 12 bits) • Conversion time <ul style="list-style-type: none"> 0.48 μs per channel (for 12-bit conversion) 0.45 μs per channel (for 10-bit conversion) 0.42 μs per channel (for 8-bit conversion) • Operating mode <ul style="list-style-type: none"> Scan mode (single scan mode, continuous scan mode, or 3 group scan mode) Group priority control (only for 3 group scan mode) • Sample-and-hold function <ul style="list-style-type: none"> Common sample-and-hold circuit included In addition, channel-dedicated sample-and-hold function (3 channels: in unit 0 only) included • Sampling variable <ul style="list-style-type: none"> Sampling time can be set up for each channel. • Digital comparison <ul style="list-style-type: none"> Method: Comparison to detect voltages above or below thresholds and window comparison Measurement: Comparison of two results of conversion or comparison of a value in the comparison register and a result of conversion • Self-diagnostic function <ul style="list-style-type: none"> The self-diagnostic function internally generates three analog input voltages (unit 0: VREFL0, VREFH0 × 1/2, VREFH0; unit 1: AVSS1, AVCC1 × 1/2, AVCC1) • Double trigger mode (A/D conversion data duplicated) • Detection of analog input disconnection • Three ways to start A/D conversion <ul style="list-style-type: none"> Software trigger, timer (MTU, TMR, TPU) trigger, external trigger • Event linking by the ELC
12-bit D/A converter (R12DAa)		<ul style="list-style-type: none"> • 2 channels • 12-bit resolution • Output voltage: 0.2 V to AVCC1 – 0.2 V (buffered output), 0 V to AVCC1 (unbuffered output) • Buffered output or unbuffered output can be selected. • Event linking by the ELC
Temperature sensor		<ul style="list-style-type: none"> • 1 channel • Relative precision: ± 1°C • The voltage of the temperature is converted into a digital value by the 12-bit A/D converter (unit 1).
Safety	Memory protection unit (MPU)	<ul style="list-style-type: none"> • Protection area: Eight areas (max.) can be specified in the range from 0000 0000h to FFFF FFFFh. • Minimum protection unit: 16 bytes • Reading from, writing to, and enabling the execution access can be specified for each area. • An access exception occurs when the detected access is not in the permitted area.
	Trusted Memory (TM) Function	<ul style="list-style-type: none"> • Programs in the TM target area in the code flash memory are protected against reading • Instruction fetching by the CPU is the only form of access to these areas when the TM function is enabled.
	Register write protection function	<ul style="list-style-type: none"> • Protects important registers from being overwritten for in case a program runs out of control.
	CRC calculator (CRCA)	<ul style="list-style-type: none"> • Generation of CRC codes for 8-/32-bit data 8-bit data <ul style="list-style-type: none"> Selectable from the following three polynomials $X^8 + X^2 + X + 1$, $X^{16} + X^{15} + X^2 + 1$, $X^{16} + X^{12} + X^5 + 1$ 32-bit data <ul style="list-style-type: none"> Selectable from the following two polynomials $X^{32} + X^{26} + X^{23} + X^{22} + X^{16} + X^{12} + X^{11} + X^{10} + X^8 + X^7 + X^5 + X^4 + X^2 + X + 1$, $X^{32} + X^{28} + X^{27} + X^{26} + X^{25} + X^{23} + X^{22} + X^{20} + X^{19} + X^{18} + X^{14} + X^{13} + X^{11} + X^{10} + X^9 + X^8 + X^6 + 1$ • Generation of CRC codes for use with LSB-first or MSB-first communications is selectable
	Main clock oscillation stop detection	<ul style="list-style-type: none"> • Main clock oscillation stop detection: Available

Table 1.1 Outline of Specifications (11/11)

Classification	Module/Function	Description
Safety	Clock frequency accuracy measurement circuit (CAC)	<ul style="list-style-type: none"> Monitors the clock output from the main clock oscillator, sub-clock oscillator, low- and high-speed on-chip oscillators, IWDT-dedicated on-chip oscillator, USB clock, Ethernet-PHY external clock, and PCLKB, and generates interrupts when the setting range is exceeded.
	Data operation circuit (DOC)	<ul style="list-style-type: none"> The function to compare, add, or subtract 16-bit data
Encryption function	Trusted Secure IP (TSIP)* ³	<ul style="list-style-type: none"> Security algorithm <ul style="list-style-type: none"> Common key encryption: AES (compliant with NIST FIPS PUB 197), TDES, ARC4 Non-common key encryption: RSA Other features <ul style="list-style-type: none"> TRNG (true-random number generator) Hash value generation: SHA1, SHA224, SHA256, MD5, GHASH Prevention of the illicit copying of keys
Operating frequency		Up to 240 MHz
Power supply voltage		$V_{CC} = AVCC0 = AVCC1 = V_{CC_USB} = 2.7$ to 3.6 V, $2.7 \leq V_{REFH0} \leq AVCC0$, $V_{BATT} = 2.0$ to 3.6 V
Operating temperature		D-version: -40 to $+85^{\circ}\text{C}$ G-version: -40 to $+105^{\circ}\text{C}$
Package		224-pin LFBGA (PLBG0224GA-A) 176-pin LFBGA (PLBG0176GA-A) 176-pin LFQFP (PLQP0176KB-C) 145-pin TFLGA (PTLG0145KA-A) 144-pin LFQFP (PLQP0144KA-B) 100-pin LFQFP (PLQP0100KB-B)
On-chip debugging system		<ul style="list-style-type: none"> E1 emulator (JTAG and FINE interfaces)

Note 1. When the realtime clock is not used, initialize the registers in the time clock according to description in section 33.6.7, Initialization Procedure When the Realtime Clock is Not to be Used in the User's Manual: Hardware.

Note 2. Magic Packet™ is a registered trademark of Advanced Micro Devices, Inc.

Note 3. The product part number differs according to whether or not the MCU includes the encryption function.

Table 1.2 Comparison of Functions for Different Packages (1/2)

Functions		RX72N			
		224 Pins	176 Pins	144 Pins/145 Pins	100 Pins
External bus	External bus width	32 bits/16 bits/8 bits		16 bits/8 bits	
	SDRAM area controller	Available			Not available
DMA	DMA controller	Ch. 0 to 7			
	Data transfer controller	Available			
	EXDMA controller	Ch. 0 and 1			
Timers	16-bit timer pulse unit	Ch. 0 to 5			
	Multi-function timer pulse unit 3	Ch. 0 to 8			
	General PWM timer	Ch. 0 to 3			
	Port output enable 3	Available			
	Port output enable for GPTW	Available			
	Programmable pulse generator	Ch. 0 and 1			
	8-bit timers	Ch. 0 to 3			
	Compare match timer	Ch. 0 to 3			
	Compare match timer W	Ch. 0 and 1			
	Realtime clock	Available			
	Watchdog timer	Available			
	Independent watchdog timer	Available			
	Communication function	Ethernet controller	Ch. 0 and 1		
PHY management interface		Ch. 0 and 1			Ch. 0
PTP controller for the ethernet controller		Available			
DMA controller for the ethernet controller		Ch. 0 and 1 (ETHERC) and 2 (EPTPC)			Ch. 0 (ETHERC) and 2 (EPTPC)
USB2.0 FS host/function module		Ch. 0			
Serial communications interfaces (SCIj)		Ch. 0 to 6			Ch. 0 to 3, 5, and 6
Serial communications interfaces (SCli)		Ch. 7 to 11			Ch. 8 to 11
Serial communications interfaces (SClh)		Ch. 12			
I ² C bus interfaces		Ch. 0 to 2			
Serial peripheral interface		Ch. 0 to 2			
CAN module		Ch. 0 to 2			Ch. 0 and 1
Quad serial peripheral interface		Ch. 0			
Expansion serial sound interface		Ch. 0 and 1			
SD host interface		Ch. 0			
Multimediacard interface		Ch. 0			
Parallel data capture unit	Available			Not available	
Graphics	Graphic-LCD controller	Available			
	2D drawing engine	Available			
12-bit A/D converter	Unit 0	AN000 to AN007 (8 channels)			
	Unit 1	AN100 to AN120 (21 channels)			AN100 to AN113 (14 channels)
12-bit D/A converter	Ch. 0 and 1			Ch. 1	
Temperature sensor	Available				
Arithmetic unit for trigonometric functions	Available				

Table 1.2 Comparison of Functions for Different Packages (2/2)

Functions	RX72N			
	224 Pins	176 Pins	144 Pins/145 Pins	100 Pins
CRC calculator	Available			
Data operation circuit	Available			
Clock frequency accuracy measurement circuit	Available			
Trusted Secure IP	Available/Not available			
Event link controller	Available			

1.2 List of Products

Table 1.3 is a list of products, and Figure 1.1 shows how to read the product part no.

Table 1.3 List of Products (1/2)

Group	Part No.	Package	Code Flash Memory Capacity	RAM Capacity	Data Flash Memory Capacity	Operating Frequency (Max.)	Encryption Module	Operating temperature (°C)
RX72N (D-version)	R5F572NNDDFC	PLQP0176KB-C	4 Mbytes	1 Mbyte	32 Kbytes	240 MHz	Not available	-40 to +85
	R5F572NNHDFC	PLQP0176KB-C	4 Mbytes	1 Mbyte	32 Kbytes	240 MHz	Available	-40 to +85
	R5F572NDDDFC	PLQP0176KB-C	2 Mbytes	1 Mbyte	32 Kbytes	240 MHz	Not available	-40 to +85
	R5F572NDHDFC	PLQP0176KB-C	2 Mbytes	1 Mbyte	32 Kbytes	240 MHz	Available	-40 to +85
	R5F572NNDDFB	PLQP0144KA-B	4 Mbytes	1 Mbyte	32 Kbytes	240 MHz	Not available	-40 to +85
	R5F572NNHDFB	PLQP0144KA-B	4 Mbytes	1 Mbyte	32 Kbytes	240 MHz	Available	-40 to +85
	R5F572NDDDFB	PLQP0144KA-B	2 Mbytes	1 Mbyte	32 Kbytes	240 MHz	Not available	-40 to +85
	R5F572NDHDFB	PLQP0144KA-B	2 Mbytes	1 Mbyte	32 Kbytes	240 MHz	Available	-40 to +85
	R5F572NNDDFP	PLQP0100KB-B	4 Mbytes	1 Mbyte	32 Kbytes	240 MHz	Not available	-40 to +85
	R5F572NNHDFP	PLQP0100KB-B	4 Mbytes	1 Mbyte	32 Kbytes	240 MHz	Available	-40 to +85
	R5F572NDDDFP	PLQP0100KB-B	2 Mbytes	1 Mbyte	32 Kbytes	240 MHz	Not available	-40 to +85
	R5F572NDHDFP	PLQP0100KB-B	2 Mbytes	1 Mbyte	32 Kbytes	240 MHz	Available	-40 to +85
	R5F572NNDDBD	PLBG0224GA-A	4 Mbytes	1 Mbyte	32 Kbytes	240 MHz	Not available	-40 to +85
	R5F572NNHDBD	PLBG0224GA-A	4 Mbytes	1 Mbyte	32 Kbytes	240 MHz	Available	-40 to +85
	R5F572NDDDBD	PLBG0224GA-A	2 Mbytes	1 Mbyte	32 Kbytes	240 MHz	Not available	-40 to +85
	R5F572NDHDBD	PLBG0224GA-A	2 Mbytes	1 Mbyte	32 Kbytes	240 MHz	Available	-40 to +85
	R5F572NNDDBG	PLBG0176GA-A	4 Mbytes	1 Mbyte	32 Kbytes	240 MHz	Not available	-40 to +85
	R5F572NNHDBG	PLBG0176GA-A	4 Mbytes	1 Mbyte	32 Kbytes	240 MHz	Available	-40 to +85
	R5F572NDDDBG	PLBG0176GA-A	2 Mbytes	1 Mbyte	32 Kbytes	240 MHz	Not available	-40 to +85
	R5F572NDHDBG	PLBG0176GA-A	2 Mbytes	1 Mbyte	32 Kbytes	240 MHz	Available	-40 to +85
RX72N (G-version)	R5F572NNDGFC	PLQP0176KB-C	4 Mbytes	1 Mbyte	32 Kbytes	240 MHz	Not available	-40 to +105
	R5F572NNHGFC	PLQP0176KB-C	4 Mbytes	1 Mbyte	32 Kbytes	240 MHz	Available	-40 to +105
	R5F572NDDGFC	PLQP0176KB-C	2 Mbytes	1 Mbyte	32 Kbytes	240 MHz	Not available	-40 to +105
	R5F572NDHGFC	PLQP0176KB-C	2 Mbytes	1 Mbyte	32 Kbytes	240 MHz	Available	-40 to +105
	R5F572NNDGFB	PLQP0144KA-B	4 Mbytes	1 Mbyte	32 Kbytes	240 MHz	Not available	-40 to +105
	R5F572NNHGFB	PLQP0144KA-B	4 Mbytes	1 Mbyte	32 Kbytes	240 MHz	Available	-40 to +105
	R5F572NDDGFB	PLQP0144KA-B	2 Mbytes	1 Mbyte	32 Kbytes	240 MHz	Not available	-40 to +105
	R5F572NDHGFB	PLQP0144KA-B	2 Mbytes	1 Mbyte	32 Kbytes	240 MHz	Available	-40 to +105
	R5F572NNDGFP	PLQP0100KB-B	4 Mbytes	1 Mbyte	32 Kbytes	240 MHz	Not available	-40 to +105
	R5F572NNHGFP	PLQP0100KB-B	4 Mbytes	1 Mbyte	32 Kbytes	240 MHz	Available	-40 to +105
	R5F572NDDGFP	PLQP0100KB-B	2 Mbytes	1 Mbyte	32 Kbytes	240 MHz	Not available	-40 to +105
	R5F572NDHGFP	PLQP0100KB-B	2 Mbytes	1 Mbyte	32 Kbytes	240 MHz	Available	-40 to +105
	R5F572NNDGBD	PLBG0224GA-A	4 Mbytes	1 Mbyte	32 Kbytes	240 MHz	Not available	-40 to +105
	R5F572NNHGBD	PLBG0224GA-A	4 Mbytes	1 Mbyte	32 Kbytes	240 MHz	Available	-40 to +105
	R5F572NDDGBD	PLBG0224GA-A	2 Mbytes	1 Mbyte	32 Kbytes	240 MHz	Not available	-40 to +105
	R5F572NDHGBD	PLBG0224GA-A	2 Mbytes	1 Mbyte	32 Kbytes	240 MHz	Available	-40 to +105
	R5F572NNDGBG	PLBG0176GA-A	4 Mbytes	1 Mbyte	32 Kbytes	240 MHz	Not available	-40 to +105
	R5F572NNHGGBG	PLBG0176GA-A	4 Mbytes	1 Mbyte	32 Kbytes	240 MHz	Available	-40 to +105
	R5F572NDDGBG	PLBG0176GA-A	2 Mbytes	1 Mbyte	32 Kbytes	240 MHz	Not available	-40 to +105
	R5F572NDHGGBG	PLBG0176GA-A	2 Mbytes	1 Mbyte	32 Kbytes	240 MHz	Available	-40 to +105

Table 1.3 List of Products (2/2)

Group	Part No.	Package	Code Flash Memory Capacity	RAM Capacity	Data Flash Memory Capacity	Operating Frequency (Max.)	Encryption Module	Operating temperature (°C)
RX72N (G-version)	R5F572NNDGLK	PTLG0145KA-A	4 Mbytes	1 Mbyte	32 Kbytes	240 MHz	Not available	-40 to +105
	R5F572NNHGLK	PTLG0145KA-A	4 Mbytes	1 Mbyte	32 Kbytes	240 MHz	Available	-40 to +105
	R5F572NDDGLK	PTLG0145KA-A	2 Mbytes	1 Mbyte	32 Kbytes	240 MHz	Not available	-40 to +105
	R5F572NDHGLK	PTLG0145KA-A	2 Mbytes	1 Mbyte	32 Kbytes	240 MHz	Available	-40 to +105

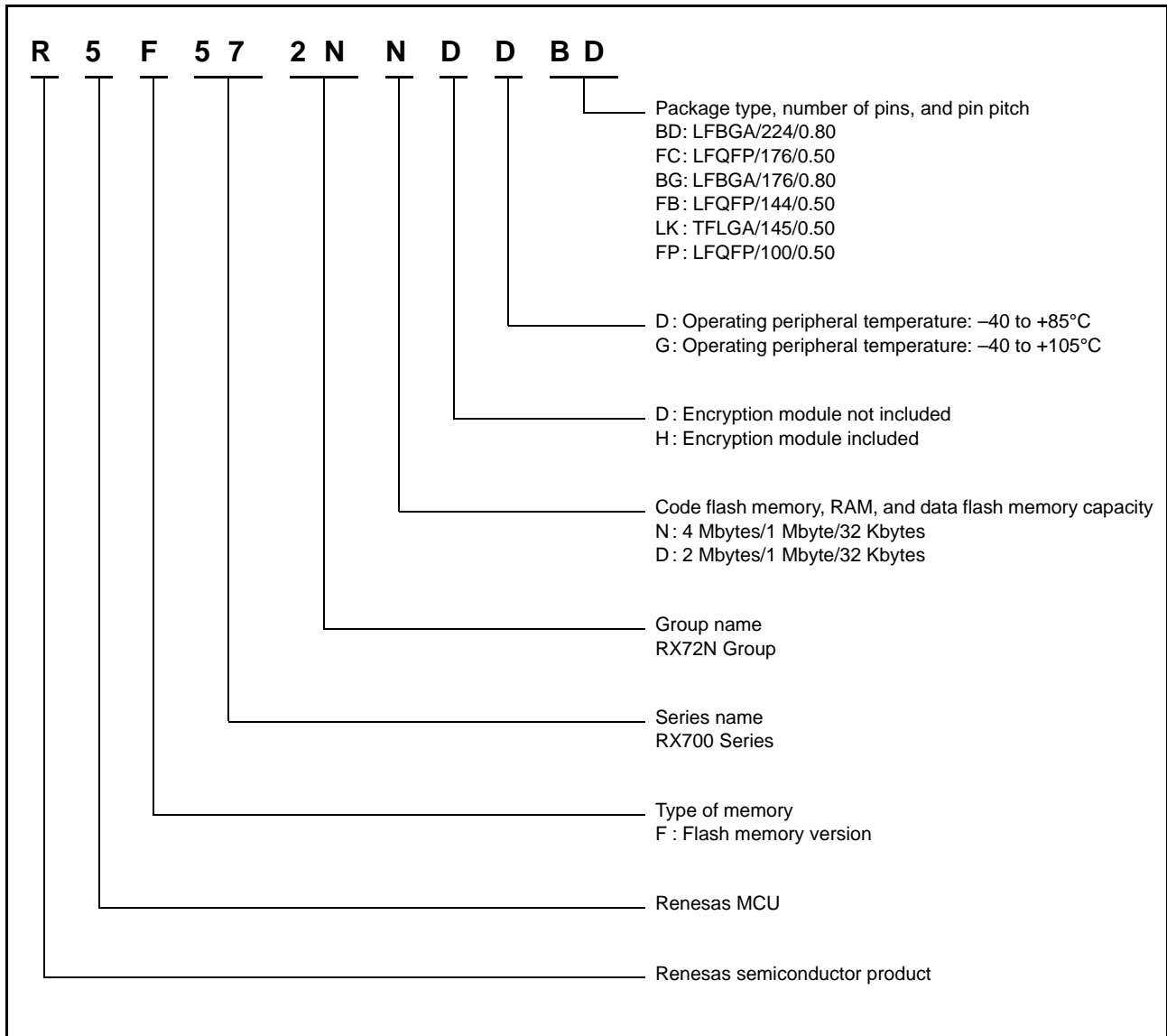

Figure 1.1 How to Read the Product Part Number

1.3 Block Diagram

Figure 1.2 shows a block diagram.

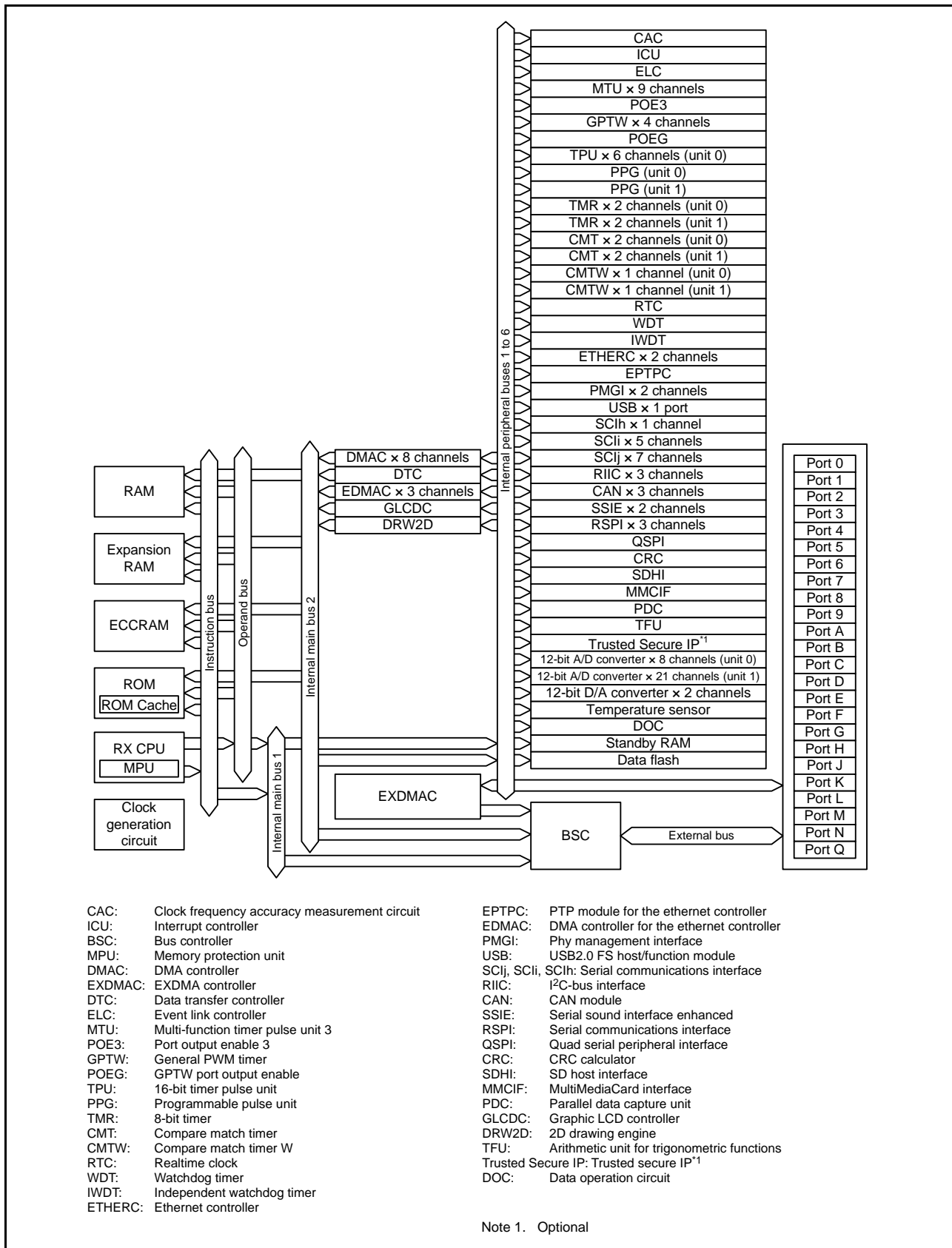

Figure 1.2 Block Diagram

1.4 Pin Functions

Table 1.4 lists the pin functions.

Table 1.4 Pin Functions (1/8)

Classifications	Pin Name	I/O	Description
Digital power supply	VCC	Input	Power supply pin. Connect this pin to the system power supply. Connect the pin to VSS via a 0.1- μ F multilayer ceramic capacitor. The capacitor should be placed close to the pin.
	VCL	Input	Connect this pin to VSS via a 0.22- μ F multilayer ceramic capacitor. The capacitor should be placed close to the pin.
	VSS	Input	Ground pin. Connect it to the system power supply (0 V).
	VBATT	Input	Backup power pin
Clock	XTAL	Output	Input/output pins for a crystal resonator. An external clock signal can be input through the EXTAL pin.
	EXTAL	Input	
	BCLK	Output	Outputs the external bus clock for external devices.
	SDCLK	Output	Outputs the SDRAM-dedicated clock.
	XCOUT	Output	Input/output pins for the sub-clock oscillator. Connect a crystal resonator between XCOUT and XCIN.
	XCIN	Input	
	CLKOUT	Output	Clock output pin.
Clock frequency accuracy measurement	CACREF	Input	Reference clock input pin for the clock frequency accuracy measurement circuit
Operating mode control	MD	Input	Input pin for setting the operating mode. The signal level on this pin must not be changed during operation.
	UB	Input	USB boot mode enable pin
	UPSEL	Input	Selects the power supply method in USB boot mode. The low level selects self-power mode and the high level selects bus power mode.
System control	RES#	Input	Reset signal input pin. This MCU enters the reset state when this signal goes low.
	EMLE	Input	Input pin for the on-chip emulator enable signal. When the on-chip emulator is used, this pin should be driven high. When not used, it should be driven low.
	BSCANP	Input	Boundary scan enable pin. Boundary scan is enabled when this pin goes high. When not used, it should be driven low.
On-chip emulator	FINED	I/O	FINE interface pin
	TRST#	Input	On-chip emulator or boundary scan pins. When the EMLE pin is driven high, these pins are dedicated for the on-chip emulator.
	TMS	Input	
	TDI	Input	
	TCK	Input	
	TDO	Output	
	TRCLK	Output	
	TRSYNC, TRSYNC1	Output	These pins indicate that output from the TRDATA0 to TRDATA7 pins is valid.
	TRDATA0 to TRDATA7	Output	These pins output the trace information.
Address bus	A0 to A23	Output	Output pins for the address
Data bus	D0 to D31	I/O	Input and output pins for the bidirectional data bus
Multiplexed bus	A0/D0 to A15/D15	I/O	Address/data multiplexed bus

Table 1.4 Pin Functions (2/8)

Classifications	Pin Name	I/O	Description
Bus control	RD#	Output	Strobe signal which indicates that reading from the external bus interface space is in progress
	WR#	Output	Strobe signal which indicates that writing to the external bus interface space is in progress, in 1-write strobe mode
	WR0# to WR3#	Output	Strobe signals which indicate that either group of data bus pins (D7 to D0, D15 to D8, D23 to D16 and D31 to D24) is valid in writing to the external bus interface space, in byte strobe mode
	BC0# to BC3#	Output	Strobe signals which indicate that either group of data bus pins (D7 to D0, D15 to D8, D23 to D16 and D31 to D24) is valid in access to the external bus interface space, in 1-write strobe mode
	ALE	Output	Address latch signal when address/data multiplexed bus is selected
	WAIT#	Input	Input pin for wait request signals in access to the external space
	CS0# to CS7#	Output	Select signals for CS areas
SDRAM interface	CKE	Output	SDRAM clock enable signal
	SDCS#	Output	SDRAM chip select signal
	RAS#	Output	SDRAM row address strobe signal
	CAS#	Output	SDRAM column address strobe signal
	WE#	Output	SDRAM write enable pin
	DQM0 to DQM3	Output	SDRAM I/O data mask enable signals
EXDMA controller	EDREQ0, EDREQ1	Input	External DMA transfer request pins
	EDACK0, EDACK1	Output	Single address transfer acknowledge signals
Interrupt	NMI	Input	Non-maskable interrupt request pin
	IRQ0 to IRQ15, IRQ0-DS to IRQ15-DS	Input	Maskable interrupt request pins
Multi-function timer pulse unit 3	MTIOC0A, MTIOC0B, MTIOC0C, MTIOC0D	I/O	The TGRA0 to TGRD0 input capture input/output compare output/PWM output pins
	MTIOC1A, MTIOC1B	I/O	The TGRA1 and TGRB1 input capture input/output compare output/PWM output pins
	MTIOC2A, MTIOC2B	I/O	The TGRA2 and TGRB2 input capture input/output compare output/PWM output pins
	MTIOC3A, MTIOC3B, MTIOC3C, MTIOC3D	I/O	The TGRA3 to TGRD3 input capture input/output compare output/PWM output pins
	MTIOC4A, MTIOC4B, MTIOC4C, MTIOC4D	I/O	The TGRA4 to TGRD4 input capture input/output compare output/PWM output pins
	MTIC5U, MTIC5V, MTIC5W	Input	The TGRU5, TGRV5, and TGRW5 input capture input/dead time compensation input pins
	MTIOC6A, MTIOC6B, MTIOC6C, MTIOC6D	I/O	The TGRA6 to TGRD6 input capture input/output compare output/PWM output pins
	MTIOC7A, MTIOC7B, MTIOC7C, MTIOC7D	I/O	The TGRA7 to TGRD7 input capture input/output compare output/PWM output pins
	MTIOC8A, MTIOC8B, MTIOC8C, MTIOC8D	I/O	The TGRA8 to TGRD8 input capture input/output compare output/PWM output pins
	MTCLKA, MTCLKB, MTCLKC, MTCLKD	Input	Input pins for external clock signals or for phase counting mode clock signals
Port output enable 3	POE0#, POE4#, POE8#, POE10#, POE11#	Input	Input pins for request signals to place the MTU in the high impedance state

Table 1.4 Pin Functions (3/8)

Classifications	Pin Name	I/O	Description
General PWM timer W	GTETRGA, GTETRGB, GTETRGC, GTETRGD	Input	Input pins for the external trigger signals
	GTIOC0A to GTIOC3A, GTIOC0B to GTIOC3B	I/O	Input capture input/output compare output/PWM output pins
	GTADSM0, GTADSM1	Output	Output pins for monitoring A/D conversion start requests.
16-bit timer pulse unit	TIOCA0, TIOCB0, TIOCC0, TIOCD0	I/O	The TGRA0 to TGRD0 input capture input/output compare output/PWM output pins
	TIOCA1, TIOCB1	I/O	The TGRA1 and TGRB1 input capture input/output compare output/PWM output pins
	TIOCA2, TIOCB2	I/O	The TGRA2 and TGRB2 input capture input/output compare output/PWM output pins
	TIOCA3, TIOCB3, TIOCC3, TIOCD3	I/O	The TGRA3 to TGRD3 input capture input/output compare output/PWM output pins
	TIOCA4, TIOCB4	I/O	The TGRA4 and TGRB4 input capture input/output compare output/PWM output pins
	TIOCA5, TIOCB5	I/O	The TGRA5 and TGRB5 input capture input/output compare output/PWM output pins
	TCLKA, TCLKB, TCLKC, TCLKD	Input	Input pins for external clock signals or for phase counting mode clock signals
Programmable pulse generator	PO0 to PO31	Output	Output pins for the pulse signals
8-bit timer	TMO0 to TMO3	Output	Compare match output pins
	TMCI0 to TMCI3	Input	Input pins for external clocks to be input to the counter
	TMRI0 to TMRI3	Input	Input pins for the counter reset
Compare match timer W	TIC0 to TIC3	Input	Input pins for CMTW
	TOC0 to TOC3	Output	Output pins for CMTW
Serial communications interface (SCIj)	• Asynchronous mode/clock synchronous mode		
	SCK0 to SCK6	I/O	Input/output pins for the clock
	RXD0 to RXD6	Input	Input pins for received data
	TXD0 to TXD6	Output	Output pins for transmitted data
	CTS0# to CTS6#	Input	Input pins for controlling the start of transmission and reception
	RTS0# to RTS6#	Output	Output pins for controlling the start of transmission and reception
	• Simple I ² C mode		
	SSCL0 to SSCL6	I/O	Input/output pins for the I ² C clock
	SSDA0 to SSDA6	I/O	Input/output pins for the I ² C data
	• Simple SPI mode		
	SCK0 to SCK6	I/O	Input/output pins for the clock
	SMISO0 to SMISO6	I/O	Input/output pins for slave transmission of data
	SMOSI0 to SMOSI6	I/O	Input/output pins for master transmission of data
	SS0# to SS6#	Input	Chip-select input pins

Table 1.4 Pin Functions (4/8)

Classifications	Pin Name	I/O	Description	
Serial communications interface (SCIh)	• Asynchronous mode/clock synchronous mode			
	SCK12	I/O	Input/output pin for the clock	
	RXD12	Input	Input pin for received data	
	TXD12	Output	Output pin for transmitted data	
	CTS12#	Input	Input pin for controlling the start of transmission and reception	
	RTS12#	Output	Output pin for controlling the start of transmission and reception	
	• Simple I ² C mode			
	SSCL12	I/O	Input/output pin for the I ² C clock	
	SSDA12	I/O	Input/output pin for the I ² C data	
	• Simple SPI mode			
	SCK12	I/O	Input/output pin for the clock	
	SMISO12	I/O	Input/output pin for slave transmission of data	
	SMOSI12	I/O	Input/output pin for master transmission of data	
	SS12#	Input	Chip-select input pin	
	• Extended serial mode			
	RDX12	Input	Input pin for received data	
	TXDX12	Output	Output pin for transmitted data	
	SIOX12	I/O	Input/output pin for received or transmitted data	
	Serial communications interface (SCIi)	• Asynchronous mode/clock synchronous mode		
		SCK7 to SCK11	I/O	Input/output pins for the clock
RXD7 to RXD11		Input	Input pins for received data	
TXD7 to TXD11		Output	Output pins for transmitted data	
CTS7# to CTS11#		Input	Input pins for controlling the start of transmission and reception	
RTS7# to RTS11#		Output	Output pins for controlling the start of transmission and reception	
• Simple I ² C mode				
SSCL7 to SSCL11		I/O	Input/output pins for the I ² C clock	
SSDA7 to SSDA11		I/O	Input/output pins for the I ² C data	
• Simple SPI mode				
SCK7 to SCK11		I/O	Input/output pins for the clock	
SMISO7 to SMISO11		I/O	Input/output pins for slave transmission of data	
SMOSI7 to SMOSI11		I/O	Input/output pins for master transmission of data	
SS7# to SS11#		Input	Chip-select input pins	
I ² C bus interface	SCL0[FM+], SCL1, SCL2, SCL2-DS	I/O	Input/output pins for clocks. Bus can be directly driven by the N-channel open drain	
	SDA0[FM+], SDA1, SDA2, SDA2-DS	I/O	Input/output pins for data. Bus can be directly driven by the N-channel open drain	

Table 1.4 Pin Functions (5/8)

Classifications	Pin Name	I/O	Description
Ethernet controller	REF50CK0, REF50CK1	Input	50-MHz reference clocks. These pins input reference signals for transmission/reception timings in RMII mode.
	RMII0_CRS_DV, RMII1_CRS_DV	Input	These pins indicate that there are carrier detection signals and valid receive data on RMII _n _RXD1 and RMII _n _RXD0 in RMII mode.
	RMII0_TXD0, RMII0_TXD1, RMII1_TXD0, RMII1_TXD1	Output	2-bit transmit data in RMII mode
	RMII0_RXD0, RMII0_RXD1, RMII1_RXD0, RMII1_RXD1	Input	2-bit receive data in RMII mode
	RMII0_TXD_EN, RMII1_TXD_EN	Output	Output pins for data transmit enable signals in RMII mode
	RMII0_RX_ER, RMII1_RX_ER	Input	These pins indicate an error has occurred during reception of data in RMII mode.
	ET0_CRS, ET1_CRS	Input	Carrier detection/data reception enable pins
	ET0_RX_DV, ET1_RX_DV	Input	These pins indicate that there are valid receive data on ET _n _ERXD3 to ET _n _ERXD0.
	ET0_EXOUT, ET1_EXOUT	Output	General-purpose external output pins
	ET0_LINKSTA, ET1_LINKSTA	Input	Input link status from the PHY-LSI.
	ET0_ETXD0 to ET0_ETXD3, ET1_ETXD0 to ET1_ETXD3	Output	4 bits of MII transmit data
	ET0_ERXD0 to ET0_ERXD3, ET1_ERXD0 to ET1_ERXD3	Input	4 bits of MII receive data
	ET0_TX_EN, ET1_TX_EN	Output	Transmit enable pins. These pins function as signals indicating that transmit data are ready on ET _n _ETXD3 to ET _n _ETXD0.
	ET0_TX_ER, ET1_TX_ER	Output	Transmit error pins. These pins function as signals notifying the PHY-LSI of an error during transmission.
	ET0_RX_ER, ET1_RX_ER	Input	Receive error pins. These pins function as signals to recognize an error during reception.
	ET0_TX_CLK, ET1_RX_CLK	Input	Transmit clock pins. These pins input reference signals for output timings from ET _n _TX_EN, ET _n _ETXD3 to ET _n _ETXD0, and ET _n _TX_ER.
	ET0_RX_CLK, ET1_RX_CLK	Input	Receive clock pins. These pins input reference signals for input timings to ET _n _RX_DV, ET _n _ERXD3 to ET _n _ERXD0, and ET _n _RX_ER.
	ET0_COL, ET1_COL	Input	Input collision detection signals.
	ET0_WOL, ET1_WOL	Output	Receive Magic packets.
	ET0_MDC, ET1_MDC	Output	Output reference clock signals for information transfer via ET _n _MDIO.
ET0_MDIO, ET1_MDIO	I/O	Input or output bidirectional signals for exchange of management information between this MCU and the PHY-LSI.	
CLKOUT25M	Output	25-MHz clock output pin for PHY clock input	
EPLSOUT0, EPLSOUT1	Output	Pulse output signals for time synchronization	
PHY management interface	PMGI0_MDC, PMGI1_MDC	Output	Reference clock signals for information transfer by PMGI _n _MDIO
	PMGI0_MDIO, PMGI1_MDIO	I/O	Bi-directional signals for the exchange of management information between the PHY LSI chip and this MCU

Table 1.4 Pin Functions (6/8)

Classifications	Pin Name	I/O	Description
USB 2.0 host/function module	VCC_USB	Input	Power supply pin
	VSS_USB	Input	Ground pin
	USB0_DP	I/O	Input or output USB transceiver D+ data.
	USB0_DM	I/O	Input or output USB transceiver D- data.
	USB0_EXICEN	Output	Connect to the OTG power IC.
	USB0_ID	Input	Connect to the OTG power IC.
	USB0_VBUSEN	Output	USB VBUS power enable pin
	USB0_OVRCURA/ USB0_OVRCURB	Input	USB overcurrent pins
	USB0_VBUS	Input	USB cable connection/disconnection detection input pin
CAN module	CRX0, CRX1, CRX2, CRX1-DS	Input	Input pins
	CTX0, CTX1, CTX2	Output	Output pins
Serial peripheral interface	RSPCKA-A/RSPCKA-B/ RSPCKB-A/RSPCKB-B/ RSPCKC-A/RSPCKC-B	I/O	Clock input/output pins
	MOSIA-A/MOSIA-B/ MOSIB-A/MOSIB-B/ MOSIC-A/MOSIC-B	I/O	Input or output data output from the master
	MISOA-A/MISOA-B/ MISOB-A/MISOB-B/ MISOC-A/MISOC-B	I/O	Input or output data output from the slave
	SSLA0-A/SSLA0-B/ SSLB0-A/SSLB0-B/ SSLC0-A/SSLC0-B	I/O	Input or output pins for slave selection
	SSLA1-A/SSLA1-B/ SSLB1-A/SSLB1-B/ SSLC1-A/SSLC1-B, SSLA2-A/SSLA2-B/ SSLB2-A/SSLB2-B/ SSLC2-A/SSLC2-B, SSLA3-A/SSLA3-B/ SSLB3-A/SSLB3-B/ SSLC3-A/SSLC3-B	Output	Output pins for slave selection
Quad serial peripheral interface	QSPCLK-A/QSPCLK-B	Output	QSPI clock output pins
	QSSL-A/QSSL-B	Output	QSPI slave output pins
	QMO-A/QMO-B, QIO0-A/QIO0-B	I/O	Master transmit data/data 0
	QMI-A/QMI-B, QIO1-A/QIO1-B	I/O	Master input data/data 1
	QIO2-A/QIO2-B, QIO3-A/QIO3-B	I/O	Data 2, data 3
Serial sound interface enhanced	SSIBCK0, SSIBCK1	I/O	SSIE serial bit-clock pins
	SSILRCK0, SSILRCK1	I/O	LR clock
	SSITXD0	Output	Serial data output pin
	SSIRXD0	Input	Serial data input pin
	SSIDATA1	I/O	Serial data input/output pin
	AUDIO_CLK	Input	External clock pin for audio (input for an oversampling clock)

Table 1.4 Pin Functions (7/8)

Classifications	Pin Name	I/O	Description
MMC host interface	MMC_CLK-A/MMC_CLK-B	Output	MMC clock pins
	MMC_CMD-A/MMC_CMD-B	I/O	Command/response pins
	MMC_D7-A/MMC_D7-B to MMC_D0-A/MMC_D0-B	I/O	Transmit data/receive data
	MMC_CD-A/MMC_CD-B	Input	Card detection pins
	MMC_RES#-A/MMC_RES#-B	Output	MMC reset output pins
SD host interface	SDHI_CLK-A/SDHI_CLK-B/ SDHI_CLK-C	Output	SD clock output pins
	SDHI_CMD-A/SDHI_CMD-B/ SDHI_CMD-C	I/O	SD command output, response input signal pins
	SDHI_D3-A/SDHI_D3-B/ SDHI_D3-C to SDHI_D0-A/ SDHI_D0-B/SDHI_D0-C	I/O	SD data bus pins
	SDHI_CD	Input	SD card detection pin
	SDHI_WP	Input	SD write-protect signal
Parallel data capture unit	PIXCLK	Input	Image transfer clock pin
	VSYNC	Input	Vertical synchronization signal pin
	HSYNC	Input	Horizontal synchronization signal pin
	PIXD0 to PIXD7	Input	8-bit image data pins
	PCKO	Output	Output pin for dot clock
Graphic-LCD controller	LCD_CLK-A, LCD_CLK-B	Output	Panel clock output pins
	LCD_TCON3-A/ LCD_TCON3-B to LCD_TCON0-A/ LCD_TCON0-B	Output	Control signal output pins
	LCD_DATA23-A/ LCD_DATA23-B to LCD_DATA0-A/ LCD_DATA0-B	Output	LCD signal output pins
	LCD_EXTCLK-A, LCD_EXTCLK-B	Input	Panel clock source input pins
Realtime clock	RTCOUT	Output	Output pin for 1-Hz/64-Hz clock
	RTCIC0 to RTCIC2	Input	Time capture event input pins
12-bit A/D converter	AN000 to AN007, AN100 to AN120	Input	Input pins for the analog signals to be processed by the A/D converter
	ADTRG0#, ADTRG1#	Input	Input pins for the external trigger signals that start the A/D conversion
	ANEX0	Output	Extended analog output pin
	ANEX1	Input	Extended analog input pin
12-bit D/A converter	DA0, DA1	Output	Output pins for the analog signals to be processed by the D/A converter

Table 1.4 Pin Functions (8/8)

Classifications	Pin Name	I/O	Description
Analog power supply	AVCC0	Input	Analog voltage supply pin for the 12-bit A/D converter (unit 0). Connect this pin to a branch from the VCC power supply. Connect the pin to AVSS0 via a 0.1- μ F multilayer ceramic capacitor. The capacitor should be placed close to the pin.
	AVSS0	Input	Analog ground pin for the 12-bit A/D converter (unit 0). Connect this pin to a branch from the VSS ground power supply. Connect the pin to AVCC0 via a 0.1- μ F multilayer ceramic capacitor. The capacitor should be placed close to the pin.
	VREFH0	Input	Analog reference voltage supply pin for the 12-bit A/D converter (unit 0). Connect this pin to VCC if the 12-bit A/D converter is not to be used.
	VREFL0	Input	Analog reference ground pin for the 12-bit A/D converter (unit 0). Connect this pin to VSS if the 12-bit A/D converter is not to be used.
	AVCC1	Input	Analog voltage supply and reference voltage supply pin for the 12-bit A/D converter (unit 1) and D/A converter. This pin also supplies the analog voltage to the temperature sensor. Connect this pin to a branch from the VCC power supply. Connect the pin to AVSS1 via a 0.1- μ F multilayer ceramic capacitor. The capacitor should be placed close to the pin.
	AVSS1	Input	Analog voltage supply and reference voltage supply pin for the 12-bit A/D converter (unit 1) and D/A converter. This pin also supplies the analog ground voltage to the temperature sensor. Connect this pin to a branch from the VSS ground power supply. Connect the pin to AVCC1 via a 0.1- μ F multilayer ceramic capacitor. The capacitor should be placed close to the pin.
I/O ports	P00 to P03, P05, P07	I/O	6-bit input/output pins
	P10 to P17	I/O	8-bit input/output pins
	P20 to P27	I/O	8-bit input/output pins
	P30 to P37	I/O	8-bit input/output pins (P35: input pin)
	P40 to P47	I/O	8-bit input/output pins
	P50 to P57	I/O	8-bit input/output pins
	P60 to P67	I/O	8-bit input/output pins
	P70 to P77	I/O	8-bit input/output pins
	P80 to P87	I/O	8-bit input/output pins
	P90 to P97	I/O	8-bit input/output pins
	PA0 to PA7	I/O	8-bit input/output pins
	PB0 to PB7	I/O	8-bit input/output pins
	PC0 to PC7	I/O	8-bit input/output pins
	PD0 to PD7	I/O	8-bit input/output pins
	PE0 to PE7	I/O	8-bit input/output pins
	PF0 to PF5	I/O	6-bit input/output pins
	PG0 to PG7	I/O	8-bit input/output pins
	PJ0 to PJ3, PJ5	I/O	5-bit input/output pins
	PH0 to PH7	I/O	8-bit input/output pins
	PK0 to PK7	I/O	8-bit input/output pins
	PL0 to PL7	I/O	8-bit input/output pins
PM0 to PM7	I/O	8-bit input/output pins	
PN0 to PN5	I/O	6-bit input/output pins	
PQ0 to PQ7	I/O	8-bit input/output pins	

Note: Note the following regarding pin names. For details, refer to section 1.5, Pin Assignments.

- We recommend using pins that have a letter (“-A”, “-B”, etc.) to indicate group membership appended to their names as

groups.

For the RSPI, QSPI, SDHI, MMC, and GLCDC interfaces, the AC portion of the electrical characteristics is measured for each group.

- When the pin functions have "-DS" appended to their names, they can also be used as triggers for release from deep software standby.
- IIC pin functions that have [FM+] appended to their names support fast-mode plus.

1.5 Pin Assignments

1.5.1 224-Pin LFBGA

**RX72N Group
PLBG0224GA-A (224-pin LFBGA)
(Upper Perspective View)**

	A	B	C	D	E	F	G	H	J	K	L	M	N	P	R	
15	P70	PE7	P66	P67	PG4	PG7	PA4	PA5	PA7	P72	PB4	PB6	PB7	PM3	PM5	15
14	PE1	PE4	P65	PG2	PG5	PG6	PA3	PA6	PB0	PB3	PB2	PC0	PC1	PM4	P74	14
13	P62	PE2	PE5	VSS	PE6	PG3	PA2	VSS	P71	PB5	VCC	PM7	PM6	PC2	P75	13
12	P61	P63	VSS	PE3	VCC	PA0	PA1	VCC	PB1	VSS	PN4	PL6	P76	PL2	PL4	12
11	PD7	VCC	P64	PE0	PQ4	PM1	PM0	PL0	PN5	PM2	P77	PL5	PK2	PC4	PC3	11
10	PG0	PD6	P60	PG1	PQ5	VSS	VCC	P73	PL1	PL3	PL7	PK0	P80	P82	PC5	10
9	PD3	PD4	P97	PD5	PQ3	PQ6	PN2	PN3	PK3	PK1	P81	P83	PC7	VSS	PC6	9
8	P96	P95	VCC	VSS	PQ1	PN1	PQ2	PQ7	P53*1	P50	P52	P51	VCC	P11	P55	8
7	PD2	P94	PD1	P93	PQ0	PK6	RES#	PJ3	P15	P10	VCC	VSS	P56	P57	P54	7
6	PD0	VCC	P90	P02	PN0	EMLE	PF5	BSCANP	PH2	PH1	PJ2	P84	PJ1	VSS_US B	USB0_D P	6
5	P92	P91	VSS	P01	P07	PK5	PJ5	P32	P30	PF0	VCC	PJ0	P13	VCC_US B	USB0_D M	5
4	P41	P46	P44	P40	P43	PK4	MD/ FINED	P33	P31	PH5	P24	VSS	P85	P14	P12	4
3	VREFL0	P42	P05	P03	P00	PF4	VCC	P35	PF3	PH4	PF1	P25	P86	P20	P16	3
2	VREFH0	AVCC0	AVCC1	P47	VSS	VBATT	VSS	P34	PF2	PH6	P27	P23	PH0	P17	P87	2
1	NC	AVSS0	AVSS1	P45	VCL	XCIN	XCOUT	XTAL	EXTAL	PH7	PH3	P26	P22	PK7	P21	1
	A	B	C	D	E	F	G	H	J	K	L	M	N	P	R	

Note: This figure indicates the power supply pins and I/O port pins. For the pin configuration, refer to Table 1.5, List of Pin and Pin Functions (224-Pin LFBGA).

Note 1. P53 is multiplexed with the BCLK pin function, so cannot be used as an I/O port pin when the external bus is enabled.

Figure 1.3 Pin Assignment (224-Pin LFBGA)

1.5.2 176-Pin LFBGA

	A	B	C	D	E	F	G	H	J	K	L	M	N	P	R		
15	PE2	PE3	P70	P65	P67	VSS	VCC	PG7	PA6	PB0	P72	PB4	VSS	VCC	PC1	15	
14	PE1	PE0	VSS	PE7	PG3	PA0	PA1	PA2	PA7	VCC	PB1	PB5	P73	P75	P74	14	
13	P63	P64	PE4	VCC	PG2	PG4	PG6	PA3	VSS	P71	PB3	PB7	PC0	PC2	P76	13	
12	P60	VSS	P62	PE5	PE6	P66	PG5	PA4	PA5	PB2	PB6	P77	PC3	PC4	P80	12	
11	PD6	PG1	VCC	P61	RX72N Group PTBG0176GA-A (176-pin LFBGA) (Upper Perspective View)								P81	P82	PC6	VCC	11
10	P97	PD4	PG0	PD7									PC5	PC7	P83	VSS	10
9	VCC	P96	PD3	PD5									P50	P51	P52	P53*1	9
8	P94	PD1	PD2	VSS									P55	P54	P10	P11	8
7	VSS	P92	PD0	P95									P85	P84	P57	P56	7
6	VCC	P91	P90	P93									PJ1	PJ0	VSS_USB	USB0_DP	6
5	P46	P47	P45	P44									PJ2	P12	VCC_USB	USB0_DM	5
4	P42	P41	P43	P00									VSS	BSCANP	PF4	P35	PF3
3	VREFL0	P40	VREFH0	P03	PF5	PJ3	MD/ FINED	RES#	P34	PF2	PF0	P24	P22	P87	P16	3	
2	AVCC0	P07	AVCC1	P02	EMLE	VCL	XCOUT	VSS	VCC	P32	P30	P26	P23	P17	P20	2	
1	AVSS0	P05	AVSS1	P01	PJ5	VBATT	XCIN	XTAL	EXTAL	P33	P31	P27	VCC	VSS	P21	1	
	A	B	C	D	E	F	G	H	J	K	L	M	N	P	R		

Note: This figure indicates the power supply pins and I/O port pins. For the pin configuration, refer to Table 1.6, List of Pin and Pin Functions (176-Pin LFBGA).

Note 1. P53 is multiplexed with the BCLK pin function, so cannot be used as an I/O port pin when the external bus is enabled.

Figure 1.4 Pin Assignment (176-Pin LFBGA)

1.5.3 176-Pin LFQFP

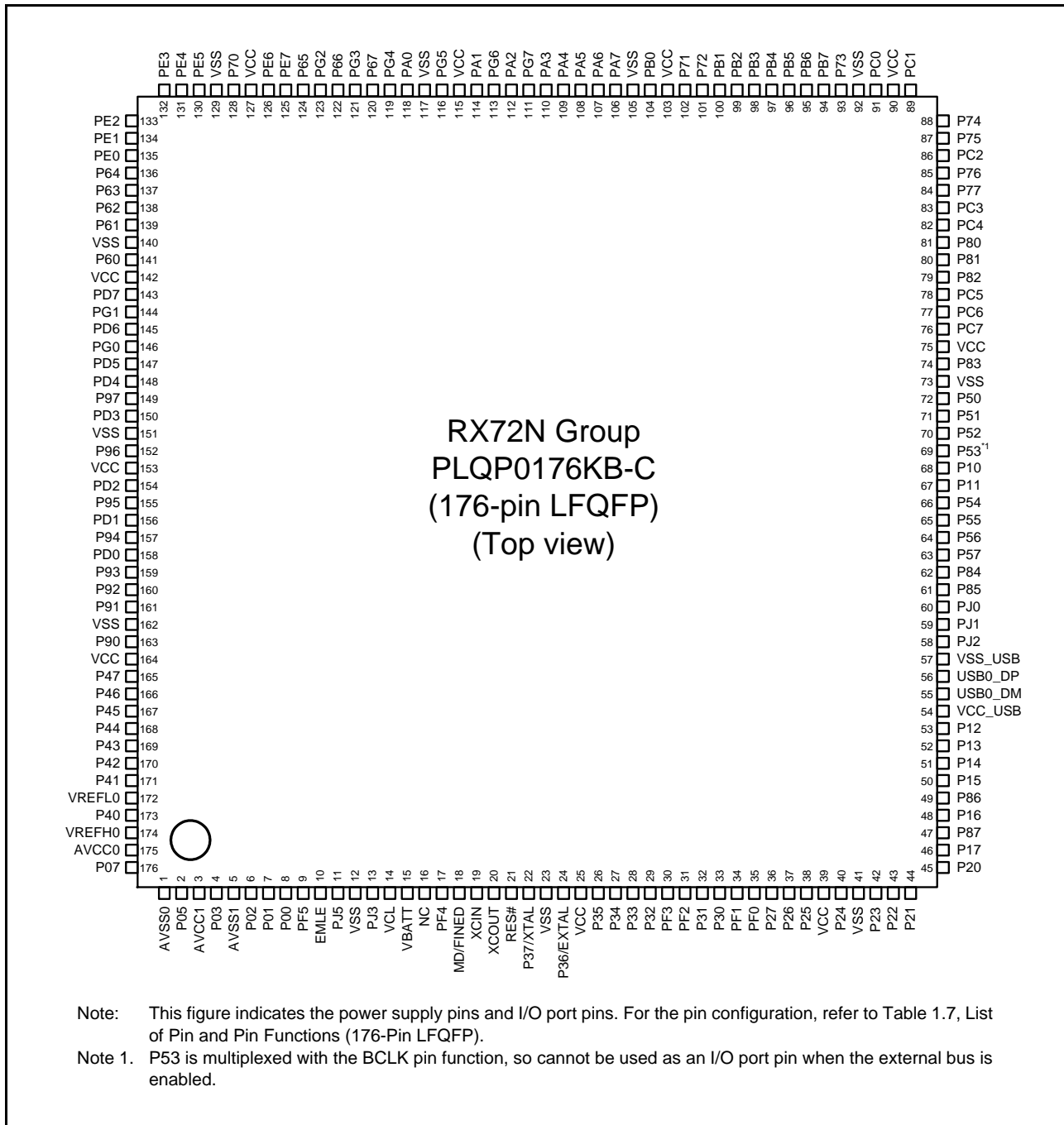

Figure 1.5 Pin Assignment (176-Pin LFQFP)

1.5.4 145-Pin TFLGA

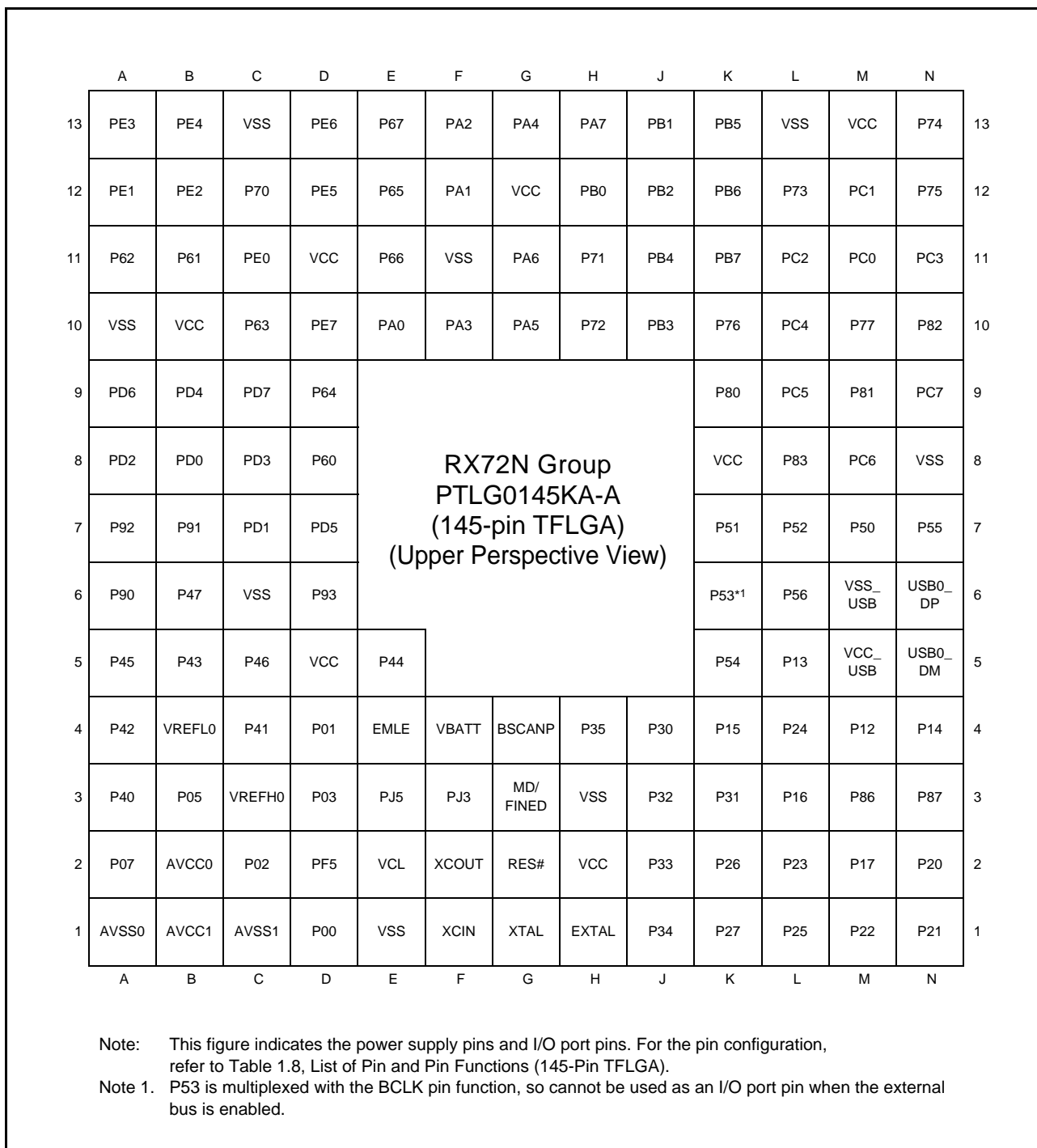

Figure 1.6 Pin Assignment (145-Pin TFLGA)

1.5.5 144-Pin LQFP

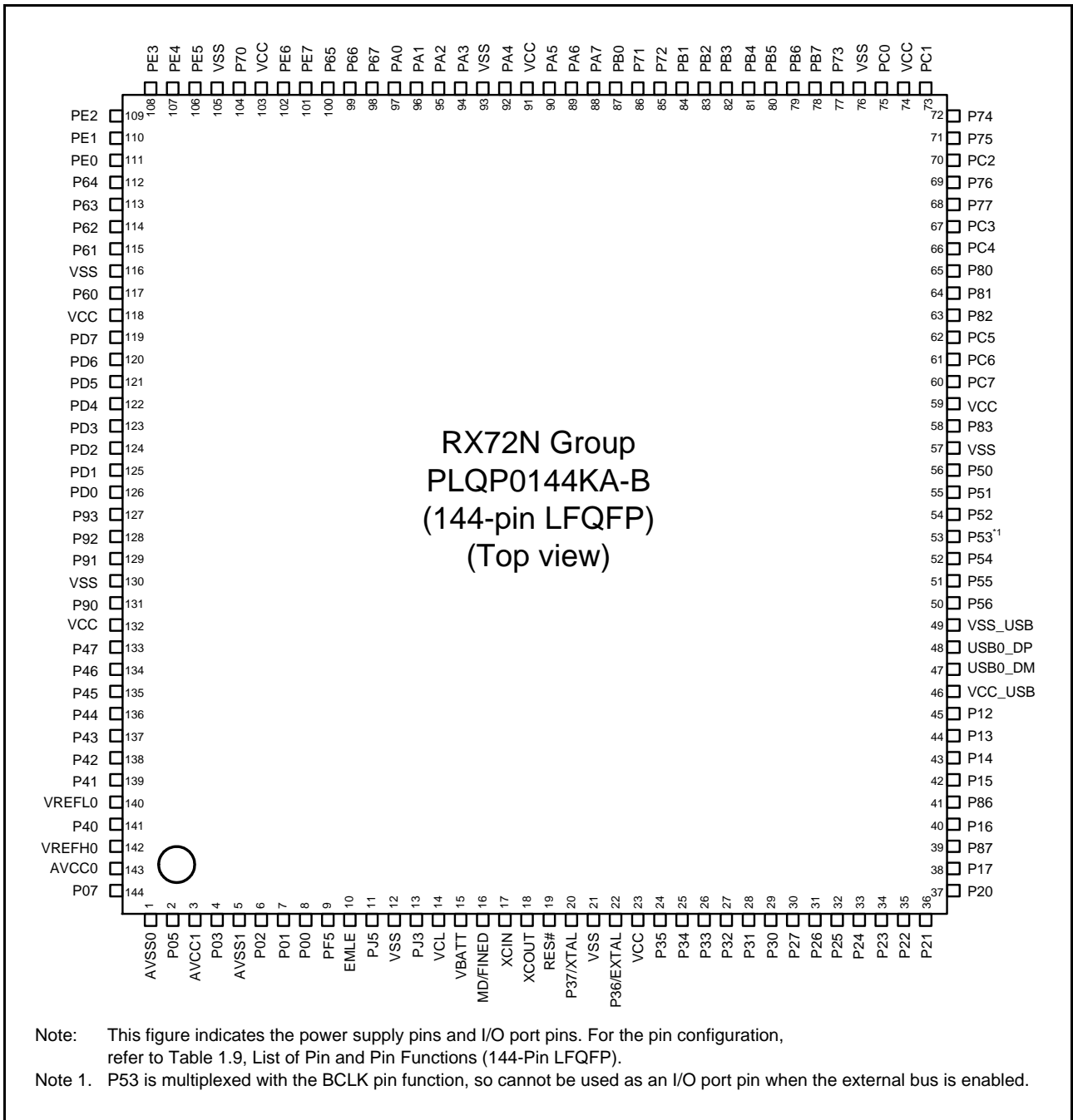

Figure 1.7 Pin Assignment (144-Pin LQFP)

1.5.6 100-Pin LFQFP

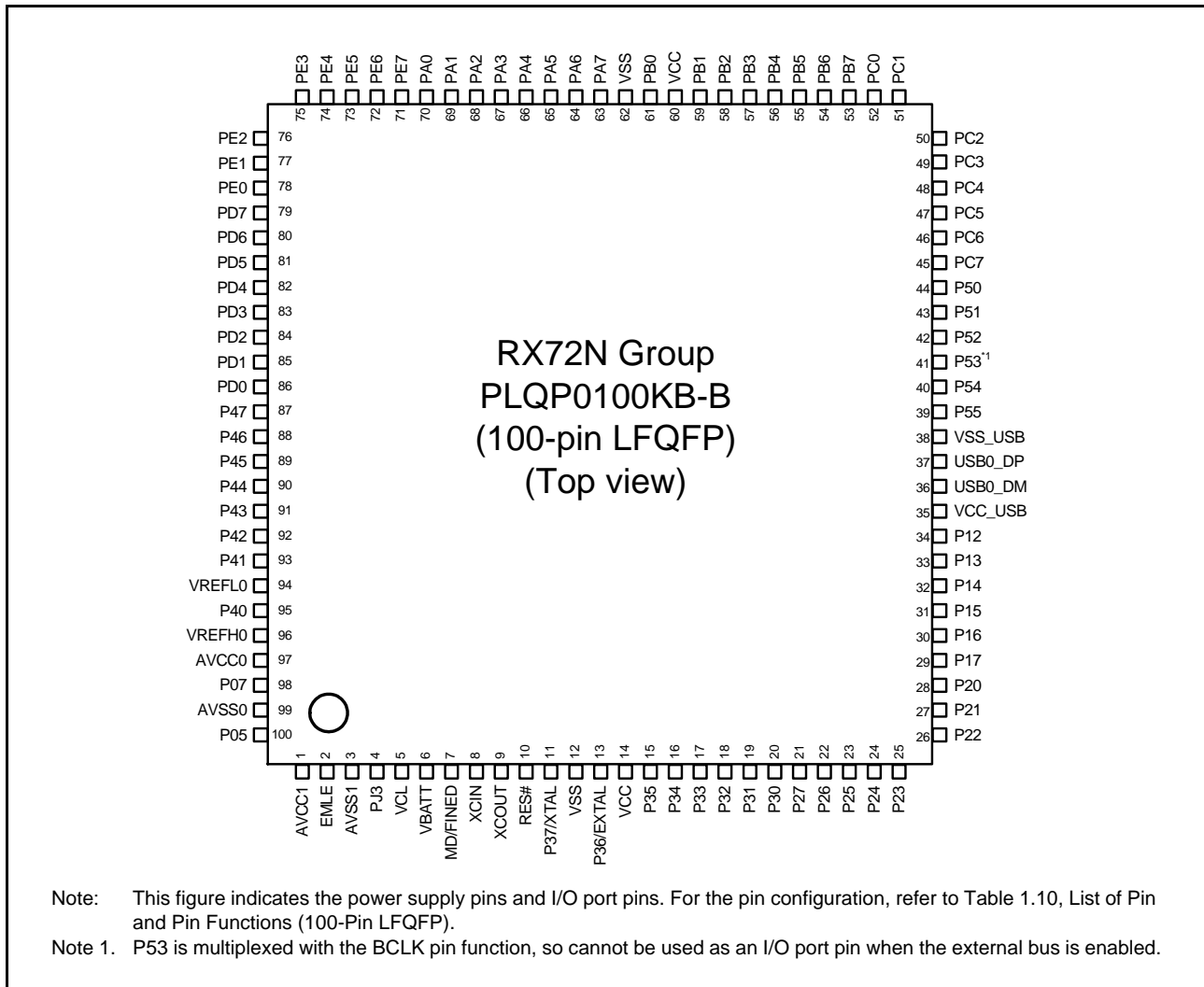

Figure 1.8 Pin Assignment (100-Pin LFQFP)

1.6 List of Pin and Pin Functions

1.6.1 224-Pin LFBGA

Table 1.5 List of Pin and Pin Functions (224-Pin LFBGA) (1/11)

Pin Number	Power Supply Clock System Control	I/O Port	Bus EXDMAC SDRAMC	Timer		Communication		Memory I/F Camera I/F	GLCDC	Interrupt	A/D D/A
				(MTU, TPU, TMR, PPG, RTC, CMTW, POE, CAC)	(GPTW, POEG)	(SCI, RSPI, RIIC, CAN, USB, SSIE)	(ETHERC, PMGI)				
A1	NC										
A2	VREFH0										
A3	VREFL0										
A4		P41								IRQ9-DS	AN001
A5		P92	D18/A18	POE4#		RXD7/ SMISO7/ SSCL7	ET1_CRS/ RMII1_CR S_DV				AN116
A6		PD0	D0[A0/D0]	POE4#	GTIOC1B				LCD_EXT CLK-B	IRQ0	AN108
A7		PD2	D2[A2/D2]	MTIOC4D/ TIC2	GTIOC0B	MISOC-A/ CRX0	ET1_EXOU T	QIO2-B/ SDHI_D2-B/ MMC_D2-B	LCD_DAT A22-B	IRQ2	AN110
A8	TRDATA5	P96	D22/A22				ET1_ERXD 2				
A9		PD3	D3[A3/D3]	MTIOC8D/ TOC2/POE8#	GTIOC0A	RSPCKC-A	ET1_WOL	QIO3-B/ SDHI_D3-B/ MMC_D3-B	LCD_DAT A21-B	IRQ3	AN111
A10	TRDATA6	PG0	D24				ET1_RX_C LK/ REF50CK1				
A11		PD7	D7[A7/D7]	MTIC5U/ POE0#		SSLC3-A	ET1_RX_E R/ RMII1_RX_ ER	QMI-B/QIO1- B/SDHI_D1-B/ MMC_D1-B	LCD_DAT A17-B	IRQ7	AN107
A12		P61	SDCS#/ D0[A0/D0]/ CS1#				ET1_ERXD 1/ RMII1_RX D1				
A13		P62	RAS#/ D1[A1/D1]/ CS2#				ET1_ERXD 0/ RMII1_RX D0				
A14		PE1	D9[A9/D9]/ D1[A1/D1]	MTIOC4C/ MTIOC3B/ PO18	GTIOC1B	TXD12/ SMOSH12/ SSDA12/ TXDX12/ SIOX12/ SSLB2-B		MMC_D5-B	LCD_DAT A15-B		ANEX1
A15		P70	SDCLK								
B1	AVSS0										
B2	AVCC0										
B3		P42								IRQ10-DS	AN002
B4		P46								IRQ14-DS	AN006
B5		P91	D17/A17			SCK7	ET1_COL				AN115
B6	VCC										
B7		P94	D20/A20				ET1_ERXD 0/ RMII1_RX D0				
B8	TRDATA4	P95	D21/A21				ET1_ERXD 1/ RMII1_RX D1				

Table 1.5 List of Pin and Pin Functions (224-Pin LFBGA) (2/11)

Pin Number	Power Supply Clock System Control	I/O Port	Bus EXDMAC SDRAMC	Timer		Communication		Memory I/F Camera I/F	GLCDC	Interrupt	A/D D/A
				(MTU, TPU, TMR, PPG, RTC, CMTW, POE, CAC)	(GPTW, POEG)	(SCI, RSPI, RIIC, CAN, USB, SSIE)	(ETHERC, PMGI)				
B9		PD4	D4[A4/D4]	MTIOC8B/ POE11#		SSLC0-A	ET1_MDIO / PMGI1_MD IO	QSSL-B/ SDHI_CMD-B/ MMC_CMD-B	LCD_DAT A20-B	IRQ4	AN112
B10		PD6	D6[A6/D6]	MTIC5V/ MTIOC8A/ POE4#		SSLC2-A	ET1_RX_C LK/ REF50CK1	QMO-B/QIO0- B/SDHI_D0-B/ MMC_D0-B	LCD_DAT A18-B	IRQ6	AN106
B11	VCC										
B12		P63	CAS#/ D2[A2/D2]/ CS3#				ET1_ETXD 1/ RMII1_TXD 1				
B13		PE2	D10[A10/ D10]/D2[A2/ D2]	MTIOC4A/ PO23/TIC3	GTIOC0B	RXD12/ SMISO12/ SSCL12/ RXDX12/ SSLB3-B		MMC_D6-B	LCD_DAT A14-B	IRQ7-DS	AN100
B14		PE4	D12[A12/ D12]/D4[A4/ D4]	MTIOC4D/ MTIOC1A/ PO28	GTIOC1A	SSLB0-B	ET0_ERXD 2		LCD_DAT A12-B		AN102
B15		PE7	D15[A15/ D15]/D7[A7/ D7]	MTIOC6A/ TOC1	GTIOC3A	MISOB-B		SDHI_WP/ MMC_RES#-B	LCD_DAT A9-B	IRQ7	AN105
C1	AVSS1										
C2	AVCC1										
C3		P05				SSILRCK1				IRQ13	DA1
C4		P44								IRQ12-DS	AN004
C5	VSS										
C6		P90	D16/A16			TXD7/ SMOSI7/ SSDA7	ET1_RX_D V				AN114
C7		PD1	D1[A1/D1]	MTIOC4B/ POE0#	GTIOC1A	MOSIC-A/ CTX0			LCD_DAT A23-B	IRQ1	AN109
C8	VCC										
C9	TRSYNC1	P97	D23/A23				ET1_ERXD 3				
C10		P60	CS0#				ET1_TX_E N/ RMII1_TXD _EN				
C11		P64	WE#/D3[A3/ D3]/CS4#				ET1_ETXD 0/ RMII1_TXD 0				
C12	VSS										
C13		PE5	D13[A13/ D13]/D5[A5/ D5]	MTIOC4C/ MTIOC2B	GTIOC0A	RSPCKB-B	ET0_RX_C LK/ REF50CK0		LCD_DAT A11-B	IRQ5	AN103
C14		P65	CKE/CS5#								
C15		P66	DQM0/ CS6#	MTIOC7D	GTIOC2B	CTX2					
D1		P45								IRQ13-DS	AN005
D2		P47								IRQ15-DS	AN007
D3		P03				SSIDATA1				IRQ11	DA0
D4		P40								IRQ8-DS	AN000
D5		P01		TMCIO		RXD6/ SMISO6/ SSCL6/ SSIBCK0		QIO3-C		IRQ9	AN119

Table 1.5 List of Pin and Pin Functions (224-Pin LFBGA) (3/11)

Pin Number	Power Supply Clock System Control	I/O Port	Bus EXDMAC SDRAMC	Timer		Communication		Memory I/F Camera I/F	GLCDC	Interrupt	A/D D/A
				(MTU, TPU, TMR, PPG, RTC, CMTW, POE, CAC)	(GPTW, POEG)	(SCI, RSPI, RIIC, CAN, USB, SSIE)	(ETHERC, PMGI)				
D6		P02		TMC11		SCK6/ SSIBCK1				IRQ10	AN120
D7		P93	D19/A19	POE0#		CTS7#/ RTS7#/SS7#	ET1_LINK STA				AN117
D8	VSS										
D9		PD5	D5[A5/D5]	MTIC5W/ MTIOC8C/ MTCLKA/ POE10#		SSL1-A	ET1_MDC/ PMGI1_MD C	QSPCLK-B/ SDHI_CLK-B/ MMC_CLK-B	LCD_DAT A19-B	IRQ5	AN113
D10	TRDATA7	PG1	D25				ET1_RX_E R/ RMII1_RX_ ER				
D11		PE0	D8[A8/D8]/ D0[A0/D0]	MTIOC3D	GTIOC2B	SCK12/ SSLB1-B		MMC_D4-B	LCD_DAT A16-B		ANEX0
D12		PE3	D11[A11/ D11]/D3[A3/ D3]	MTIOC4B/ PO26/TOC3/ POE8#	GTIOC2A	CTS12#/ RTS12#/ SS12#	ET0_ERXD 3	MMC_D7-B	LCD_DAT A13-B		AN101
D13	VSS										
D14	TRDATA0	PG2	D26				ET1_TX_C LK				
D15		P67	DQM1/ CS7#	MTIOC7C	GTIOC1B	CRX2	EPLSOUT1			IRQ15	
E1	VCL										
E2	VSS										
E3		P00		TMRI0		TXD6/ SMOSI6/ SSDA6/ AUDIO_CLK		QIO2-C		IRQ8	AN118
E4		P43								IRQ11-DS	AN003
E5		P07								IRQ15	ADTRG0#
E6		PN0					ET1_ETXD 2				
E7		PQ0				SCK11	ET1_CRS/ RMII1_CR S_DV				
E8		PQ1				SMISO11/ SSCL11/ RXD11	ET1_COL				
E9		PQ3				RTS11#/ CTS11#/ SS11#	ET1_TX_E R				
E10		PQ5					ET1_ETXD 0/ RMII1_TXD 0				
E11		PQ4					ET1_RX_C LK/ REF50CK1				
E12	VCC										
E13		PE6	D14[A14/ D14]/D6[A6/ D6]	MTIOC6C/ TIC1	GTIOC3B	MOSIB-B		SDHI_CD/ MMC_CD-B	LCD_DAT A10-B	IRQ6	AN104
E14	TRCLK	PG5	D29				ET1_ETXD 2				
E15	TRSYNC	PG4	D28				ET1_ETXD 1/ RMII1_TXD 1				
F1	XCIN										

Table 1.5 List of Pin and Pin Functions (224-Pin LFBGA) (4/11)

Pin Number	Power Supply Clock System Control	I/O Port	Bus EXDMAC SDRAMC	Timer		Communication		Memory I/F Camera I/F	GLCDC	Interrupt	A/D D/A
				(MTU, TPU, TMR, PPG, RTC, CMTW, POE, CAC)	(GPTW, POEG)	(SCI, RSPI, RIIC, CAN, USB, SSIE)	(ETHERC, PMGI)				
F2	VBATT										
F3	TRST#	PF4									
F4		PK4			GTADSM0	SSLB1	ET0_ERXD2				
F5		PK5			GTADSM1	SSLB2	ET0_ERXD3				
F6	EMLE										
F7		PK6			GTIOC1A	SSLB3					
F8		PN1					ET1_ETXD3				
F9		PQ6					ET1_ETXD1/ RMII1_TXD1				
F10	VSS										
F11		PM1		TOC3	GTETRGB	SMISO10/ SSCL10/ RXD10	ET1_ERXD1/ RMII1_RXD1	SDHL_CMD-D/ QSSL-A			
F12		PA0	DQM2/ BC0#/A0	MTIOC4A/ MTIOC6D/ TIOCA0/PO16/ CACREF	GTIOC0B	SSLA1-B	ET0_TX_EN/ RMII0_TXD_EN		LCD_DAT A8-B		
F13	TRDATA1	PG3	D27				ET1_ETXD0/ RMII1_TXD0				
F14	TRDATA2	PG6	D30				ET1_ETXD3				
F15	TRDATA3	PG7	D31				ET1_TX_ER				
G1	XCOU										
G2	VSS										
G3	VCC										
G4	MD/FINED										
G5		PJ5		POE8#		CTS2#/ RTS2#/ SS2#/ SSIRXD0	EPLSOUT0	QMI-C/QIO1-C			
G6		PF5	WAIT#			SSILRCK0				IRQ4	
G7	RES#										
G8		PQ2				SMOSI11/ SSDA11/ TXD11	ET1_RX_DV				
G9		PN2					ET1_TX_CLK				
G10	VCC										
G11		PM0		TIC3	GTETRGA	SCK10	ET1_ERXD0/ RMII1_RXD0	SDHL_CLK-D/ QSPCLK-A			
G12		PA1	DQM3/A1	MTIOC0B/ MTCLCK/ MTIOC7B/ TIOCB0/PO17	GTIOC2A	SCK5/ SSLA2-B	ET0_WOL		LCD_DAT A7-B	IRQ11	
G13		PA2	A2	MTIOC7A/ PO18	GTIOC1A	RXD5/ SMISO5/ SSCL5/ SSLA3-B			LCD_DAT A6-B		

Table 1.5 List of Pin and Pin Functions (224-Pin LFBGA) (5/11)

Pin Number	Power Supply Clock System Control	I/O Port	Bus EXDMAC SDRAMC	Timer		Communication		Memory I/F Camera I/F	GLCDC	Interrupt	A/D D/A
				(MTU, TPU, TMR, PPG, RTC, CMTW, POE, CAC)	(GPTW, POEG)	(SCI, RSPI, RIIC, CAN, USB, SSIE)	(ETHERC, PMGI)				
G14		PA3	A3	MTIOC0D/ MTCLKD/ TIOCD0/ TCLKB/PO19		RXD5/ SMISO5/ SSCL5	ET0_MDIO / PMGIO_MD IO		LCD_DAT A5-B	IRQ6-DS	
G15		PA4	A4	MTIC5U/ MTCLKA/ TIOCA1/ TMRI0/PO20		TXD5/ SMOSI5/ SSDA5/ SSLA0-B	ET0_MDC/ PMGIO_MD C		LCD_DAT A4-B	IRQ5-DS	
H1	XTAL	P37									
H2		P34		MTIOC0A/ TMC13/PO12/ POE10#		SCK6/SCK0	ET0_LINK STA			IRQ4	
H3	UPSEL	P35								NMI	
H4		P33	EDREQ1	MTIOC0D/ TIOCD0/ TMRI3/PO11/ POE4#/ POE11#		RXD6/ SMISO6/ SSCL6/ RXD0/ SMISO0/ SSCL0/ CRX0		PCKO		IRQ3-DS	
H5		P32		MTIOC0C/ TIOCC0/ TMO3/PO10/ RTCIC2/ RTCOUT/ POE0#/ POE10#		TXD6/ SMOSI6/ SSDA6/ TXD0/ SMOSI0/ SSDA0/ CTX0/ USB0_VBUS EN		VSYNC		IRQ2-DS	
H6	BSCANP										
H7		PJ3	EDACK1	MTIOC3C		CTS6#/ RTS6#/ SS6#/ CTS0#/ RTS0#/ SS0#/ SSITXD0	ET0_EXOU T	QMO-C/QIOO- C			
H8		PQ7					ET1_TX_E N/ RMII1_TXD _EN				
H9		PN3					ET1_RX_E R/ RMII1_RX_ ER				
H10		P73	CS3#	PO16			ET0_WOL		LCD_EXT CLK-A		
H11		PL0		TIC2	GTETRGA	SCK9/ RSPCKC	ET0_ERXD 0/ RMII0_RX D0				
H12	VCC										
H13	VSS										
H14		PA6	A6	MTIC5V/ MTCLKB/ TIOCA2/ TMC13/PO22/ POE10#	GTETRGA	CTS5#/ RTS5#/ SS5#/ MOSIA-B	ET0_EXOU T		LCD_DAT A2-B		
H15		PA5	A5	MTIOC6B/ TIOCB1/PO21	GTIOC0A	RSPCKA-B	ET0_LINK STA		LCD_DAT A3-B		
J1	EXTAL	P36									
J2	TDI	PF2				RXD1/ SMISO1/ SSCL1					

Table 1.5 List of Pin and Pin Functions (224-Pin LFBGA) (6/11)

Pin Number	Power Supply Clock System Control	I/O Port	Bus EXDMAC SDRAMC	Timer		Communication		Memory I/F Camera I/F	GLCDC	Interrupt	A/D D/A
				(MTU, TPU, TMR, PPG, RTC, CMTW, POE, CAC)	(GPTW, POEG)	(SCI, RSPI, RIIC, CAN, USB, SSIE)	(ETHERC, PMGI)				
J3	TMS	PF3									
J4		P31		MTIOC4D/ TMC12/PO9/ RTCIC1		CTS1#/ RTS1#/ SS1#/ SSLB0-A	ET1_MDC/ PMGI1_MD C			IRQ1-DS	
J5		P30		MTIOC4B/ TMRI3/PO8/ RTCIC0/ POE8#		RXD1/ SMISO1/ SSCL1/ MISOB-A	ET1_MDIO / PMGI1_MD IO			IRQ0-DS	
J6		PH2			GTETRG C	SMOSI7/ SSDA7/ TXD7/MISOA					
J7		P15		MTIOC0B/ MTCLKB/ TIOCB2/ TCLKB/TMC12/ PO13	GTETRGA	RXD1/ SMISO1/ SSCL1/ SCK3/CRX1- DS/ SSILRCK1		PIXD0		IRQ5	
J8		P53*1	BCLK								
J9		PK3			GTETRG D	RTS8#/ CTS8#/ SS8#/ SSLB0	ET0_TX_E R				
J10		PL1		TOC2	GTETRGB	SMISO9/ SSCL9/ RXD9/ MOSIC	ET0_ERXD 1/ RMII0_RX D1				
J11		PN5					ET1_MDC/ PMGI1_MD C	QSSL-C			
J12		PB1	A9	MTIOC0C/ MTIOC4C/ TIOCB3/ TMC10/PO25		TXD4/ SMOSI4/ SSDA4/ TXD6/ SMOSI6/ SSDA6	ET0_ERXD 0/ RMII0_RX D0		LCD_TCO N3-B	IRQ4-DS	
J13		P71	A18/CS1#				ET0_MDIO / PMGI0_MD IO				
J14		PB0	A8	MTIC5W/ TIOCA3/PO24		RXD4/ SMISO4/ SSCL4/ RXD6/ SMISO6/ SSCL6	ET0_ERXD 1/ RMII0_RX D1		LCD_DAT A0-B	IRQ12	
J15		PA7	A7	TIOCB2/PO23		MISOA-B	ET0_WOL		LCD_DAT A1-B		
K1	CLKOUT2 5M	PH7			GTIOC0B						
K2	CLKOUT	PH6			GTIOC0A	SSLA3					
K3		PH4			GTADSM0	SSLA1					
K4		PH5			GTADSM1	SSLA2					
K5	TDO	PF0				TXD1/ SMOSI1/ SSDA1					
K6		PH1		TOC0	GTETRGB	SMISO7/ SSCL7/ RXD7/ MOSIA					
K7		P10	ALE	MTIC5W/ TMRI3						IRQ0	

Table 1.5 List of Pin and Pin Functions (224-Pin LFBGA) (7/11)

Pin Number	Power Supply Clock System Control	I/O Port	Bus EXDMAC SDRAMC	Timer		Communication		Memory I/F Camera I/F	GLCDC	Interrupt	A/D D/A
				(MTU, TPU, TMR, PPG, RTC, CMTW, POE, CAC)	(GPTW, POEG)	(SCI, RSPI, RIIC, CAN, USB, SSIE)	(ETHERC, PMGI)				
K8		P50	WR0#/WR#			TXD2/ SMOSI2/ SSDA2/ SSLB1-A					
K9		PK1		TOC1	GTETRGB	SMISO8/ SSCL8/ RXD8/ MOSIB	ET0_COL				
K10		PL3			GTETRGD	RTS9#/ CTS9#/ SS9#/ SSL0	ET0_RX_C LK/ REF50CK0				
K11		PM2			GTETRGC	SMOSI10/ SSDA10/ TXD10	ET1_ERXD 2	SDHL_D0-D/ QMO-A/QIO0-A			
K12	VSS										
K13		PB5	A13	MTIOC2A/ MTIOC1B/ TIOCB4/ TMRI1/PO29/ POE4#		SCK9/ RTS9#/ SCK11	ET0_ETXD 0/ RMII0_TXD 0		LCD_CLK- B		
K14		PB3	A11	MTIOC0A/ MTIOC4A/ TIOCD3/ TCLKD/TMO0/ PO27/POE11#		SCK4/SCK6	ET0_RX_E R/ RMII0_RX_ ER		LCD_TCO N1-B		
K15		P72	A19/CS2#				ET0_MDC/ PMGIO_MD C		LCD_DAT A23-A		
L1		PH3			GTETRGD	RTS7#/ CTS7#/ SS7#/ SSL0					
L2		P27	CS7#	MTIOC2B/ TMCI3/PO7		SCK1/ RSPCKB-A	ET1_WOL				
L3	TCK	PF1				SCK1					
L4		P24	CS4#/ EDREQ1	MTIOC4A/ MTCLKA/ TIOCB4/ TMRI1/PO4		SCK3/ USB0_VBUS EN/SSIBCK1		SDHL_WP/ PIXCLK			
L5	VCC										
L6	CLKOUT2 5M	PJ2				TXD8/ SMOSI8/ SSDA8/ SSLC3-B			LCD_TCO N2-A		
L7	VCC										
L8		P52	RD#			RXD2/ SMISO2/ SSCL2/ SSLB3-A					
L9		P81	EDACK0	MTIOC3D/ PO27	GTIOC0B	SMISO10/ SSCL10/ RXD10	ET0_ETXD 0/ RMII0_TXD 0	QIO3-A/ SDHL_CD/ MMC_D3-A	LCD_DAT A13-A		
L10		PL7			GTIOC2B		ET0_MDIO / PMGIO_MD IO				
L11		P77	CS7#	PO23		SMOSI11/ SSDA11/ TXD11	ET0_RX_E R/ RMII0_RX_ ER	QSPCLK-A/ SDHL_CLK-A/ MMC_CLK-A	LCD_DAT A17-A		
L12		PN4					ET1_MDIO / PMGI1_MD IO	QSPCLK-C			

Table 1.5 List of Pin and Pin Functions (224-Pin LFBGA) (8/11)

Pin Number	Power Supply Clock System Control	I/O Port	Bus EXDMAC SDRAMC	Timer		Communication		Memory I/F Camera I/F	GLCDC	Interrupt	A/D D/A
				(MTU, TPU, TMR, PPG, RTC, CMTW, POE, CAC)	(GPTW, POEG)	(SCI, RSPI, RIIC, CAN, USB, SSIE)	(ETHERC, PMGI)				
L13	VCC										
L14		PB2	A10	TIOCC3/ TCLKC/PO26		CTS4#/ RTS4#/ SS4#/ CTS6#/ RTS6#/SS6#	ET0_RX_C LK/ REF50CK0		LCD_TCO N2-B		
L15		PB4	A12	TIOCA4/PO28		CTS9#/ SS9#/SS11#/ CTS11#/ RTS11#	ET0_TX_E N/ RMII0_TXD _EN		LCD_TCO N0-B		
M1		P26	CS6#	MTIOC2A/ TMO1/PO6		TXD1/ SMOSI1/ SSDA1/ CTS3#/ RTS3#/ SS3#/ MOSIB-A	ET1_EXOU T				
M2		P23	EDACK0	MTIOC3D/ MTCLKD/ TIOCD3/PO3	GTIOC0A	TXD3/ SMOSI3/ SSDA3/ CTS0#/ RTS0#/ SS0#/CTX1/ SSIBCK0		SDHL_D1-C/ PIXD7			
M3	CLKOUT	P25	CS5#/ EDACK1	MTIOC4C/ MTCLKB/ TIOCA4/PO5		RXD3/ SMISO3/ SSCL3/ SSIDATA1		SDHL_CD/ HSYNC			ADTRG0#
M4	VSS										
M5		PJ0		MTIOC6B		SCK8/ SSLC1-B	EPLSOUT0		LCD_DAT A0-A		
M6		P84		MTIOC6D			ET1_LINK STA		LCD_DAT A2-A		
M7	VSS										
M8		P51	WR1#/ BC1#/ WAIT#			SCK2/ SSLB2-A					
M9		P83	EDACK1	MTIOC4C	GTIOC0A	SCK10/ SS10#/ CTS10#	ET0_CRS/ RMII0_CR S_DV		LCD_DAT A8-A		
M10		PK0		TIC1	GTETRGA	SCK8/ RSPCKB	ET0_MDC/ PMGIO_MD C				
M11		PL5			GTADSM1	SSLC2	ET0_ETXD 1/ RMII0_TXD 1				
M12		PL6			GTIOC2A	SSLC3	ET0_TX_E N/ RMII0_TXD _EN				
M13		PM7			GTIOC3B		ET0_CRS/ RMII0_CR S_DV	SDHL_WP			
M14		PC0	A16	MTIOC3C/ TCLKC/PO17		CTS5#/ RTS5#/ SS5#/ SSLA1-A	ET0_ERXD 3			IRQ14	
M15		PB6	A14	MTIOC3D/ TIOCA5/PO30		RXD9/ SMISO9/ SSCL9/ SMISO11/ SSCL11/ RXD11	ET0_ETXD 1/ RMII0_TXD 1				

Table 1.5 List of Pin and Pin Functions (224-Pin LFBGA) (9/11)

Pin Number	Power Supply Clock System Control	I/O Port	Bus EXDMAC SDRAMC	Timer		Communication		Memory I/F Camera I/F	GLCDC	Interrupt	A/D D/A
				(MTU, TPU, TMR, PPG, RTC, CMTW, POE, CAC)	(GPTW, POEG)	(SCI, RSPI, RIIC, CAN, USB, SSIE)	(ETHERC, PMGI)				
N1		P22	EDREQ0	MTIOC3B/ MTCLKC/ TIOCC3/ TMO0/PO2	GTIOC1A	SCK0/ USB0_OVRC URB/ AUDIO_CLK		SDHL_D0-C/ PIXD6			
N2		PH0		TIC0	GTETRGA	SCK7/ RSPCKA					
N3		P86		MTIOC4D/ TIOCA0	GTIOC2B	SMISO10/ SSCL10/ RXD10		PIXD1			
N4		P85		MTIOC6C/ TIOCC0					LCD_DAT A1-A		
N5		P13	WR2#/BC2#	MTIOC0B/ TIOCA5/ TMO3/PO13	GTADSM1	TXD2/ SMOSI2/ SSDA2/ SDA0[FM+]			LCD_TCO N0-A	IRQ3	ADTRG1#
N6		PJ1		MTIOC6A		RXD8/ SMISO8/ SSCL8/ SSLC2-B	EPLSOUT1		LCD_TCO N3-A		
N7	CLKOUT2 5M	P56	EDACK1	MTIOC3C/ TIOCA1		SCK7/ RSPCKC-B			LCD_DAT A4-A		
N8	VCC										
N9	UB	PC7	A23/CS0#	MTIOC3A/ MTCLKB/ TMO2/PO31/ TOC0/ CACREF	GTIOC3A	TXD8/ SMOSI8/ SSDA8/ SMOSI10/ SSDA10/ TXD10/ MISOA-A	ET0_COL	MMC_D7-A	LCD_DAT A9-A	IRQ14	
N10		P80	EDREQ0	MTIOC3B/ PO26		SCK10/ RTS10#	ET0_TX_E N/ RMII0_TXD _EN	QIO2-A/ SDHL_WP/ MMC_D2-A	LCD_DAT A14-A		
N11		PK2			GTETRGC	SMOSI8/ SSDA8/ TXD8/MISOB	ET0_RX_D V				
N12		P76	CS6#	PO22		SMISO11/ SSCL11/ RXD11	ET0_RX_C LK/ REF50CK0	QSSL-A/ SDHL_CMD-A/ MMC_CMD-A	LCD_DAT A18-A		
N13		PM6			GTIOC3A		ET0_TX_C LK	SDHL_CD			
N14		PC1	A17	MTIOC3A/ TCLKD/PO18		SCK5/ SSLA2-A	ET0_ERXD 2		LCD_DAT A22-A	IRQ12	
N15		PB7	A15	MTIOC3B/ TIOCB5/PO31		TXD9/ SMOSI9/ SSDA9/ SMOSI11/ SSDA11/ TXD11	ET0_CRS/ RMII0_CR S_DV				
P1		PK7			GTIOC1B						
P2		P17		MTIOC3A/ MTIOC3B/ MTIOC4B/ TIOCB0/ TCLKD/TMO1/ PO15/POE8#	GTIOC0B	SCK1/TXD3/ SMOSI3/ SSDA3/ SDA2-DS/ SSITXD0	EPLSOUT0	SDHL_D3-C/ PIXD3		IRQ7	ADTRG1#
P3		P20		MTIOC1A/ TIOCB3/ TMRI0/PO0		TXD0/ SMOSI0/ SSDA0/ SDA1/ USB0_ID/ SSIRXD0		SDHL_CMD-C/ PIXD4		IRQ8	

Table 1.5 List of Pin and Pin Functions (224-Pin LFBGA) (10/11)

Pin Number	Power Supply Clock System Control	I/O Port	Bus EXDMAC SDRAMC	Timer		Communication		Memory I/F Camera I/F	GLCDC	Interrupt	A/D D/A
				(MTU, TPU, TMR, PPG, RTC, CMTW, POE, CAC)	(GPTW, POEG)	(SCI, RSPI, RIIC, CAN, USB, SSIE)	(ETHERC, PMGI)				
P4		P14		MTIOC3A/ MTCLKA/ TIOCB5/ TCLKA/TMRI2/ PO15	GTETRG D	CTS1#/ RTS1#/ SS1#/CTX1/ USB0_OVRC URA			LCD_CLK- A	IRQ4	
P5	VCC_USB										
P6	VSS_USB										
P7		P57				RXD7/ SMISO7/ SSCL7/ SSLC0-B			LCD_DAT A3-A		
P8		P11		MTIC5V/ TMC13		SCK2	EPLSOUT1		LCD_DAT A7-A	IRQ1	
P9	VSS										
P10		P82	EDREQ1	MTIOC4A/ PO28	GTIOC2A	SMOSI10/ SSDA10/ TXD10	ET0_ETXD 1/ RMII0_TXD 1	MMC_D4-A	LCD_DAT A12-A		
P11		PC4	A20/CS3#	MTIOC3D/ MTCLKC/ TMC1/PO25/ POE0#	GTETRG C	SCK5/ CTS8#/ SS8#/SS10#/ CTS10#/ RTS10#/ SSLA0-A	ET0_TX_C LK	QMI-A/QIO1- A/SDHI_D1-A/ MMC_D1-A	LCD_DAT A15-A		
P12		PL2			GTETRG C	SMOSI9/ SSDA9/ TXD9/ MISOC	ET0_RX_E R/ RMII0_RX_ ER				
P13		PC2	A18	MTIOC4B/ TCLKA/PO21	GTIOC2B	RXD5/ SMISO5/ SSCL5/ SSLA3-A	ET0_RX_D V	SDHI_D3-A/ MMC_CD-A	LCD_DAT A19-A		
P14		PM4			GTADSM0		ET0_ETXD 2	SDHI_D2-D/ QIO2-A			
P15		PM3			GTETRG D	RTS10#/ CTS10#/ SS10#	ET1_ERXD 3	SDHI_D1-D/ QMI-A/QIO1-A			
R1		P21		MTIOC1B/ MTIOC4A/ TIOCA3/ TMC10/PO1	GTIOC2A	RXD0/ SMISO0/ SSCL0/ SCL1/ USB0_EXIC EN/ SSILRCK0		SDHI_CLK-C/ PIXD5		IRQ9	
R2		P87		MTIOC4C/ TIOCA2	GTIOC1B	SMOSI10/ SSDA10/ TXD10	EPLSOUT1	SDHI_D2-C/ PIXD2			
R3		P16		MTIOC3C/ MTIOC3D/ TIOCB1/ TCLKC/TMO2/ PO14/ RTCOUT		TXD1/ SMOSI1/ SSDA1/ RXD3/ SMISO3/ SSCL3/ SCL2-DS/ USB0_VBUS EN/ USB0_VBUS / USB0_OVRC URB				IRQ6	ADTRG0#
R4		P12	WR3#/BC3#	MTIC5U/ TMC11	GTADSM0	RXD2/ SMISO2/ SSCL2/ SCL0[FM+]			LCD_TCO N1-A	IRQ2	
R5						USB0_DM					
R6						USB0_DP					

Table 1.5 List of Pin and Pin Functions (224-Pin LFBGA) (11/11)

Pin Number	Power Supply Clock System Control	I/O Port	Bus EXDMAC SDRAMC	Timer		Communication		Memory I/F Camera I/F	GLCDC	Interrupt	A/D D/A
				(MTU, TPU, TMR, PPG, RTC, CMTW, POE, CAC)	(GPTW, POEG)	(SCI, RSPI, RIIC, CAN, USB, SSIE)	(ETHERC, PMGI)				
R7		P54	D1[A1/D1]/ EDACK0/ ALE	MTIOC4B/ TMC11		CTS2#/ RTS2#/ SS2#/ MOSIC-B/ CTX1	ET0_LINK STA		LCD_DAT A6-A		
R8		P55	D0[A0/D0]/ EDREQ0/ WAIT#	MTIOC4D/ TMO3		TXD7/ SMOSI7/ SSDA7/ MISOC-B/ CRX1	ET0_EXOU T		LCD_DAT A5-A	IRQ10	
R9		PC6	D2[A2/D2]/ A22/CS1#	MTIOC3C/ MTCLKA/ TMC12/PO30/ TIC0	GTIOC3B	RXD8/ SMISO8/ SSCL8/ SMISO10/ SSCL10/ RXD10/ MOSIA-A	ET0_ETXD 3	MMC_D6-A	LCD_DAT A10-A	IRQ13	
R10		PC5	D3[A3/D3]/ A21/CS2#/ WAIT#	MTIOC3B/ MTCLKD/ TMRI2/PO29	GTIOC1A	SCK8/ RTS8#/ SCK10/ RSPCKA-A	ET0_ETXD 2	MMC_D5-A	LCD_DAT A11-A		
R11		PC3	A19	MTIOC4D/ TCLKB/PO24	GTIOC1B	TXD5/ SMOSI5/ SSDA5	ET0_TX_E R	QMO-A/QIO0- A/SDHI_D0-A/ MMC_D0-A	LCD_DAT A16-A		
R12		PL4			GTADSM0	SSLC1	ET0_ETXD 0/ RMII0_TXD 0				
R13		P75	CS5#	PO20		SCK11/ RTS11#	ET0_ERXD 0/ RMII0_RX D0	SDHI_D2-A/ MMC_RES#-A	LCD_DAT A20-A		
R14		P74	A20/CS4#	PO19		SS11#/ CTS11#	ET0_ERXD 1/ RMII0_RX D1		LCD_DAT A21-A		
R15		PM5			GTADSM1		ET0_ETXD 3	SDHI_D3-D/ QIO3-A			

Note 1. P53 is multiplexed with the BCLK pin function, so cannot be used as an I/O port pin when the external bus is enabled.

1.6.2 176-Pin LFBGA

Table 1.6 List of Pin and Pin Functions (176-Pin LFBGA) (1/9)

Pin Number	Power Supply Clock System Control	I/O Port	Bus EXDMAC SDRAMC	Timer		Communication		Memory I/F Camera I/F	GLCDC	Interrupt	A/D D/A
				(MTU, TPU, TMR, PPG, RTC, CMTW, POE, CAC)	(GPTW, POEG)	(SCI, RSPI, RIIC, CAN, USB, SSIE)	(ETHERC, PMGI)				
176-Pin LFBGA											
A1	AVSS0										
A2	AVCC0										
A3	VREFL0										
A4		P42								IRQ10-DS	AN002
A5		P46								IRQ14-DS	AN006
A6	VCC										
A7	VSS										
A8		P94	D20/A20				ET1_ERXD0/ RMII1_RXD0				
A9	VCC										
A10	TRSYNC1	P97	D23/A23				ET1_ERXD3				
A11		PD6	D6[A6/D6]	MTIOC5V/ MTIOC8A/ POE4#		SSLC2-A	ET1_RX_CLK/ REF50CK1	QMO-B/QIO0-B/ SDHI_D0-B/ MMC_D0-B	LCD_DAT A18-B	IRQ6	AN106
A12		P60	CS0#				ET1_TX_EN/ RMII1_TXD_EN				
A13		P63	CAS#/ D2[A2/D2]/ CS3#				ET1_ETXD1/ RMII1_TXD1				
A14		PE1	D9[A9/D9]/ D1[A1/D1]	MTIOC4C/ MTIOC3B/ PO18	GTIOC1B	TXD12/ SMOSH12/ SSDA12/ TXDX12/ SIOX12/ SSLB2-B		MMC_D5-B	LCD_DAT A15-B		ANEX1
A15		PE2	D10[A10/ D10]/D2[A2/ D2]	MTIOC4A/ PO23/TIC3	GTIOC0B	RXD12/ SMISO12/ SSCL12/ RXDX12/ SSLB3-B		MMC_D6-B	LCD_DAT A14-B	IRQ7-DS	AN100
B1		P05								IRQ13	DA1
B2		P07								IRQ15	ADTRG0#
B3		P40								IRQ8-DS	AN000
B4		P41								IRQ9-DS	AN001
B5		P47								IRQ15-DS	AN007
B6		P91	D17/A17			SCK7	ET1_COL				AN115
B7		P92	D18/A18	POE4#		RXD7/ SMISO7/ SSCL7	ET1_CRS/ RMII1_CR S_DV				AN116
B8		PD1	D1[A1/D1]	MTIOC4B/ POE0#	GTIOC1A	MOSIC-A/ CTX0			LCD_DAT A23-B	IRQ1	AN109
B9	TRDATA5	P96	D22/A22				ET1_ERXD2				
B10		PD4	D4[A4/D4]	MTIOC8B/ POE11#		SSLC0-A	ET1_MDIO/ PMGI1_MDIO	QSSL-B/ SDHI_CMD-B/ MMC_CMD-B	LCD_DAT A20-B	IRQ4	AN112

Table 1.6 List of Pin and Pin Functions (176-Pin LFBGA) (2/9)

Pin Number	Power Supply Clock System Control	I/O Port	Bus EXDMAC SDRAMC	Timer		Communication		Memory I/F Camera I/F	GLCDC	Interrupt	A/D D/A
				(MTU, TPU, TMR, PPG, RTC, CMTW, POE, CAC)	(GPTW, POEG)	(SCI, RSPI, RIIC, CAN, USB, SSIE)	(ETHERC, PMGI)				
176-Pin LFBGA											
B11	TRDATA7	PG1	D25				ET1_RX_ER/ RMII1_RX_ER				
B12	VSS										
B13		P64	WE#/D3[A3/D3]/CS4#				ET1_ETXD0/ RMII1_TXD0				
B14		PE0	D8[A8/D8]/D0[A0/D0]	MTIOC3D	GTIOC2B	SCK12/ SSLB1-B		MMC_D4-B	LCD_DAT A16-B		ANEX0
B15		PE3	D11[A11/D11]/D3[A3/D3]	MTIOC4B/ PO26/TOC3/ POE8#	GTIOC2A	CTS12#/ RTS12#/ SS12#	ET0_ERXD3	MMC_D7-B	LCD_DAT A13-B		AN101
C1	AVSS1										
C2	AVCC1										
C3	VREFH0										
C4		P43								IRQ11-DS	AN003
C5		P45								IRQ13-DS	AN005
C6		P90	D16/A16			TXD7/ SMOSI7/ SSDA7	ET1_RX_DV				AN114
C7		PD0	D0[A0/D0]	POE4#	GTIOC1B				LCD_EXT CLK-B	IRQ0	AN108
C8		PD2	D2[A2/D2]	MTIOC4D/ TIC2	GTIOC0B	MISOC-A/ CRX0	ET1_EXOUT	QIO2-B/ SDHL_D2-B/ MMC_D2-B	LCD_DAT A22-B	IRQ2	AN110
C9		PD3	D3[A3/D3]	MTIOC8D/ TOC2/POE8#	GTIOC0A	RSPCKC-A	ET1_WOL	QIO3-B/ SDHL_D3-B/ MMC_D3-B	LCD_DAT A21-B	IRQ3	AN111
C10	TRDATA6	PG0	D24				ET1_RX_CLK/ REF50CK1				
C11	VCC										
C12		P62	RAS#/D1[A1/D1]/CS2#				ET1_ERXD0/ RMII1_RXD0				
C13		PE4	D12[A12/D12]/D4[A4/D4]	MTIOC4D/ MTIOC1A/ PO28	GTIOC1A	SSLB0-B	ET0_ERXD2		LCD_DAT A12-B		AN102
C14	VSS										
C15		P70	SDCLK								
D1		P01		TMCI0		RXD6/ SMISO6/ SSCL6/ SSIBCK0				IRQ9	AN119
D2		P02		TMCI1		SCK6/ SSIBCK1				IRQ10	AN120
D3		P03				SSIDATA1				IRQ11	DA0
D4		P00		TMRI0		TXD6/ SMOSI6/ SSDA6/ AUDIO_CLK				IRQ8	AN118
D5		P44								IRQ12-DS	AN004
D6		P93	D19/A19	POE0#		CTS7#/ RTS7#/ SS7#	ET1_LINK STA				AN117

Table 1.6 List of Pin and Pin Functions (176-Pin LFBGA) (3/9)

Pin Number	Power Supply Clock System Control	I/O Port	Bus EXDMAC SDRAMC	Timer		Communication		Memory I/F Camera I/F	GLCDC	Interrupt	A/D D/A
				(MTU, TPU, TMR, PPG, RTC, CMTW, POE, CAC)	(GPTW, POEG)	(SCI, RSPI, RIIC, CAN, USB, SSIE)	(ETHERC, PMGI)				
D7	TRDATA4	P95	D21/A21				ET1_ERXD1/ RMII1_RXD1				
D8	VSS										
D9		PD5	D5[A5/D5]	MTIC5W/ MTIOC8C/ MTCLKA/ POE10#		SSLC1-A	ET1_MDC/ PMGI1_MD C	QSPCLK-B/ SDHL_CLK-B/ MMC_CLK-B	LCD_DAT A19-B	IRQ5	AN113
D10		PD7	D7[A7/D7]	MTIC5U/ POE0#		SSLC3-A	ET1_RX_ER/ RMII1_RX_ER	QMI-B/QIO1-B/ SDHL_D1-B/ MMC_D1-B	LCD_DAT A17-B	IRQ7	AN107
D11		P61	SDCS#/ D0[A0/D0]/ CS1#				ET1_ERXD1/ RMII1_RXD1				
D12		PE5	D13[A13/ D13]/D5[A5/ D5]	MTIOC4C/ MTIOC2B	GTIOC0A	RSPCKB-B	ET0_RX_C LK/ REF50CK0		LCD_DAT A11-B	IRQ5	AN103
D13	VCC										
D14		PE7	D15[A15/ D15]/D7[A7/ D7]	MTIOC6A/ TOC1	GTIOC3A	MISOB-B		SDHL_WP/ MMC_RES#-B	LCD_DAT A9-B	IRQ7	AN105
D15		P65	CKE/CS5#								
E1		PJ5		POE8#		CTS2#/ RTS2#/ SS2#/ SSIRXD0	EPLSOUT0				
E2	EMLE										
E3		PF5	WAIT#				SSILRCK0			IRQ4	
E4	VSS										
E12		PE6	D14[A14/ D14]/D6[A6/ D6]	MTIOC6C/ TIC1	GTIOC3B	MOSIB-B		SDHL_CD/ MMC_CD-B	LCD_DAT A10-B	IRQ6	AN104
E13	TRDATA0	PG2	D26				ET1_TX_C LK				
E14	TRDATA1	PG3	D27				ET1_ETXD0/ RMII1_TXD0				
E15		P67	DQM1/ CS7#	MTIOC7C	GTIOC1B	CRX2	EPLSOUT1			IRQ15	
F1	VBATT										
F2	VCL										
F3		PJ3	EDACK1	MTIOC3C		CTS6#/ RTS6#/ SS6#/ CTS0#/ RTS0#/ SS0#/ SSITXD0	ET0_EXOU T				
F4	BSCANP										
F12		P66	DQM0/ CS6#	MTIOC7D	GTIOC2B	CTX2					
F13	TRSYNC	PG4	D28				ET1_ETXD1/ RMII1_TXD1				

Table 1.6 List of Pin and Pin Functions (176-Pin LFBGA) (4/9)

Pin Number	Power Supply Clock System Control	I/O Port	Bus EXDMAC SDRAMC	Timer		Communication		Memory I/F Camera I/F	GLCDC	Interrupt	A/D D/A
				(MTU, TPU, TMR, PPG, RTC, CMTW, POE, CAC)	(GPTW, POEG)	(SCI, RSPI, RIIC, CAN, USB, SSIE)	(ETHERC, PMGI)				
F14		PA0	DQM2/BC0#/A0	MTIOC4A/ MTIOC6D/ TIOCA0/PO16/ CACREF	GTIOC0B	SSLA1-B	ET0_TX_EN/ RMII0_TXD_EN		LCD_DAT A8-B		
F15	VSS										
G1	XCIN										
G2	XCOU										
G3	MD/FINED										
G4	TRST#	PF4									
G12	TRCLK	PG5	D29				ET1_ETXD2				
G13	TRDATA2	PG6	D30				ET1_ETXD3				
G14		PA1	DQM3/A1	MTIOC0B/ MTCLK/ MTIOC7B/ TIOCB0/PO17	GTIOC2A	SCK5/ SSLA2-B	ET0_WOL		LCD_DAT A7-B	IRQ11	
G15	VCC										
H1	XTAL	P37									
H2	VSS										
H3	RES#										
H4	UPSEL	P35								NMI	
H12		PA4	A4	MTIC5U/ MTCLKA/ TIOCA1/ TMRI0/PO20		TXD5/ SMOSI5/ SSDA5/ SSLA0-B	ET0_MDC/ PMGIO_MD C		LCD_DAT A4-B	IRQ5-DS	
H13		PA3	A3	MTIOC0D/ MTCLKD/ TIOCD0/ TCLKB/PO19		RXD5/ SMISO5/ SSCL5	ET0_MDIO/ PMGIO_MD IO		LCD_DAT A5-B	IRQ6-DS	
H14		PA2	A2	MTIOC7A/ PO18	GTIOC1A	RXD5/ SMISO5/ SSCL5/ SSLA3-B			LCD_DAT A6-B		
H15	TRDATA3	PG7	D31				ET1_TX_ER				
J1	EXTAL	P36									
J2	VCC										
J3		P34		MTIOC0A/ TMCI3/PO12/ POE10#		SCK6/SCK0	ET0_LINK STA			IRQ4	
J4	TMS	PF3									
J12		PA5	A5	MTIOC6B/ TIOCB1/PO21	GTIOC0A	RSPCKA-B	ET0_LINK STA		LCD_DAT A3-B		
J13	VSS										
J14		PA7	A7	TIOCB2/PO23		MISOA-B	ET0_WOL		LCD_DAT A1-B		
J15		PA6	A6	MTIC5V/ MTCLKB/ TIOCA2/ TMCI3/PO22/ POE10#	GTETRGB	CTS5#/ RTS5#/ SS5#/ MOSIA-B	ET0_EXOU T		LCD_DAT A2-B		
K1		P33	EDREQ1	MTIOC0D/ TIOCD0/ TMRI3/PO11/ POE4#/ POE11#		RXD6/ SMISO6/ SSCL6/ RXD0/ SMISO0/ SSCL0/ CRX0		PCKO		IRQ3-DS	

Table 1.6 List of Pin and Pin Functions (176-Pin LFBGA) (5/9)

Pin Number	Power Supply Clock System Control	I/O Port	Bus EXDMAC SDRAMC	Timer		Communication		Memory I/F Camera I/F	GLCDC	Interrupt	A/D D/A
				(MTU, TPU, TMR, PPG, RTC, CMTW, POE, CAC)	(GPTW, POEG)	(SCI, RSPI, RIIC, CAN, USB, SSIE)	(ETHERC, PMGI)				
K2		P32		MTIOC0C/ TIOCC0/ TMO3/PO10/ RTCIC2/ RTCOU0/ POE0#/ POE10#		TXD6/ SMOSI6/ SSDA6/ TXD0/ SMOSI0/ SSDA0/ CTX0/ USB0_VBUS EN		VSYNC		IRQ2-DS	
K3	TDI	PF2				RXD1/ SMISO1/ SSCL1					
K4	TCK	PF1				SCK1					
K12		PB2	A10	TIOCC3/ TCLKC/PO26		CTS4#/ RTS4#/ SS4#/ CTS6#/ RTS6#/SS6#	ET0_RX_C LK/ REF50CK0		LCD_TCO N2-B		
K13		P71	A18/CS1#				ET0_MDIO / PMGIO_MD IO				
K14	VCC										
K15		PB0	A8	MTIC5W/ TIOCA3/PO24		RXD4/ SMISO4/ SSCL4/ RXD6/ SMISO6/ SSCL6	ET0_ERXD 1/ RMII0_RX D1		LCD_DAT A0-B	IRQ12	
L1		P31		MTIOC4D/ TMC12/PO9/ RTCIC1		CTS1#/ RTS1#/ SS1#/ SSLB0-A	ET1_MDC/ PMGI1_MD C			IRQ1-DS	
L2		P30		MTIOC4B/ TMRI3/PO8/ RTCIC0/ POE8#		RXD1/ SMISO1/ SSCL1/ MISOB-A	ET1_MDIO / PMGI1_MD IO			IRQ0-DS	
L3	TDO	PF0				TXD1/ SMOSI1/ SSDA1					
L4	CLKOUT	P25	CS5#/ EDACK1	MTIOC4C/ MTCLKB/ TIOCA4/PO5		RXD3/ SMISO3/ SSCL3/ SSIDATA1		SDHL_CD/ HSYNC			ADTRG0#
L12		PB6	A14	MTIOC3D/ TIOCA5/PO30		RXD9/ SMISO9/ SSCL9/ SMISO11/ SSCL11/ RXD11	ET0_ETXD 1/ RMII0_TXD 1				
L13		PB3	A11	MTIOC0A/ MTIOC4A/ TIOCD3/ TCLKD/TMO0/ PO27/POE11#		SCK4/SCK6	ET0_RX_E R/ RMII0_RX_ ER		LCD_TCO N1-B		
L14		PB1	A9	MTIOC0C/ MTIOC4C/ TIOCB3/ TMC10/PO25		TXD4/ SMOSI4/ SSDA4/ TXD6/ SMOSI6/ SSDA6	ET0_ERXD 0/ RMII0_RX D0		LCD_TCO N3-B	IRQ4-DS	
L15		P72	A19/CS2#				ET0_MDC/ PMGIO_MD C		LCD_DAT A23-A		
M1		P27	CS7#	MTIOC2B/ TMC13/PO7		SCK1/ RSPCKB-A	ET1_WOL				

Table 1.6 List of Pin and Pin Functions (176-Pin LFBGA) (6/9)

Pin Number	Power Supply Clock System Control	I/O Port	Bus EXDMAC SDRAMC	Timer		Communication		Memory I/F Camera I/F	GLCDC	Interrupt	A/D D/A
				(MTU, TPU, TMR, PPG, RTC, CMTW, POE, CAC)	(GPTW, POEG)	(SCI, RSPI, RIIC, CAN, USB, SSIE)	(ETHERC, PMGI)				
176-Pin LFBGA											
M2		P26	CS6#	MTIOC2A/ TMO1/PO6		TXD1/ SMOSI1/ SSDA1/ CTS3#/ RTS3#/ SS3#/ MOSIB-A	ET1_EXOU T				
M3		P24	CS4#/ EDREQ1	MTIOC4A/ MTCLKA/ TIOCB4/ TMRI1/PO4		SCK3/ USB0_VBUS EN/SSIBCK1		SDHL_WP/ PIXCLK			
M4		P86		MTIOC4D/ TIOCA0	GTIOC2B	SMISO10/ SSCL10/ RXD10		PIXD1			
M5	CLKOUT2 5M	PJ2				TXD8/ SMOSI8/ SSDA8/ SSLC3-B			LCD_TCO N2-A		
M6		PJ1		MTIOC6A		RXD8/ SMISO8/ SSCL8/ SSLC2-B	EPLSOUT1		LCD_TCO N3-A		
M7		P85		MTIOC6C/ TIOCC0					LCD_DAT A1-A		
M8		P55	D0[A0/D0]/ EDREQ0/ WAIT#	MTIOC4D/ TMO3		TXD7/ SMOSI7/ SSDA7/ MISOC-B/ CRX1	ET0_EXOU T		LCD_DAT A5-A	IRQ10	
M9		P50	WR0#/WR#			TXD2/ SMOSI2/ SSDA2/ SSLB1-A					
M10		PC5	D3[A3/D3]/ A21/CS2#/ WAIT#	MTIOC3B/ MTCLKD/ TMRI2/PO29	GTIOC1A	SCK8/ RTS8#/ SCK10/ RSPCKA-A	ET0_ETXD 2	MMC_D5-A	LCD_DAT A11-A		
M11		P81	EDACK0	MTIOC3D/ PO27	GTIOC0B	SMISO10/ SSCL10/ RXD10	ET0_ETXD 0/ RMII0_TXD 0	QIO3-A/ SDHI_CD/ MMC_D3-A	LCD_DAT A13-A		
M12		P77	CS7#	PO23		SMOSI11/ SSDA11/ TXD11	ET0_RX_E R/ RMII0_RX_ ER	QSPCLK-A/ SDHI_CLK-A/ MMC_CLK-A	LCD_DAT A17-A		
M13		PB7	A15	MTIOC3B/ TIOCB5/PO31		TXD9/ SMOSI9/ SSDA9/ SMOSI11/ SSDA11/ TXD11	ET0_CRS/ RMII0_CR S_DV				
M14		PB5	A13	MTIOC2A/ MTIOC1B/ TIOCB4/ TMRI1/PO29/ POE4#		SCK9/ RTS9#/ SCK11	ET0_ETXD 0/ RMII0_TXD 0		LCD_CLK- B		
M15		PB4	A12	TIOCA4/PO28		CTS9#/ SS9#/SS11#/ CTS11#/ RTS11#	ET0_TX_E N/ RMII0_TXD _EN		LCD_TCO N0-B		
N1	VCC										

Table 1.6 List of Pin and Pin Functions (176-Pin LFBGA) (7/9)

Pin Number	Power Supply Clock System Control	I/O Port	Bus EXDMAC SDRAMC	Timer		Communication		Memory I/F Camera I/F	GLCDC	Interrupt	A/D D/A
				(MTU, TPU, TMR, PPG, RTC, CMTW, POE, CAC)	(GPTW, POEG)	(SCI, RSPI, RIIC, CAN, USB, SSIE)	(ETHERC, PMGI)				
176-Pin LFBGA											
N2		P23	EDACK0	MTIOC3D/ MTCLKD/ TIOCD3/PO3	GTIOC0A	TXD3/ SMOSI3/ SSDA3/ CTS0#/ RTS0#/ SS0#/CTX1/ SSIBCK0		SDHI_D1-C/ PIXD7			
N3		P22	EDREQ0	MTIOC3B/ MTCLKC/ TIOCC3/ TMO0/PO2	GTIOC1A	SCK0/ USB0_OVRC URB/ AUDIO_CLK		SDHI_D0-C/ PIXD6			
N4		P15		MTIOC0B/ MTCLKB/ TIOCB2/ TCLKB/TMC12/ PO13	GTETRGA	RXD1/ SMISO1/ SSCL1/ SCK3/CRX1- DS/ SSILRCK1		PIXD0		IRQ5	
N5		P12	WR3#/BC3#	MTIC5U/ TMC1	GTADSM0	RXD2/ SMISO2/ SSCL2/ SCL0[FM+]			LCD_TCO N1-A	IRQ2	
N6		PJ0		MTIOC6B		SCK8/ SSLC1-B	EPLSOUT0		LCD_DAT A0-A		
N7		P84		MTIOC6D			ET1_LINK STA		LCD_DAT A2-A		
N8		P54	D1[A1/D1]/ EDACK0/ ALE	MTIOC4B/ TMC1		CTS2#/ RTS2#/ SS2#/ MOSIC-B/ CTX1	ET0_LINK STA		LCD_DAT A6-A		
N9		P51	WR1#/ BC1#/ WAIT#			SCK2/ SSLB2-A					
N10	UB	PC7	A23/CS0#	MTIOC3A/ MTCLKB/ TMO2/PO31/ TOC0/ CACREF	GTIOC3A	TXD8/ SMOSI8/ SSDA8/ SMOSI10/ SSDA10/ TXD10/ MISOA-A	ET0_COL	MMC_D7-A	LCD_DAT A9-A	IRQ14	
N11		P82	EDREQ1	MTIOC4A/ PO28	GTIOC2A	SMOSI10/ SSDA10/ TXD10	ET0_ETXD 1/ RMII0_TXD 1	MMC_D4-A	LCD_DAT A12-A		
N12		PC3	A19	MTIOC4D/ TCLKB/PO24	GTIOC1B	TXD5/ SMOSI5/ SSDA5	ET0_TX_E R	QMO-A/QIO0- A/SDHI_D0-A/ MMC_D0-A	LCD_DAT A16-A		
N13		PC0	A16	MTIOC3C/ TCLKC/PO17		CTS5#/ RTS5#/ SS5#/ SSLA1-A	ET0_ERXD 3			IRQ14	
N14		P73	CS3#	PO16			ET0_WOL		LCD_EXT CLK-A		
N15	VSS										
P1	VSS										
P2		P17		MTIOC3A/ MTIOC3B/ MTIOC4B/ TIOCB0/ TCLKD/TMO1/ PO15/POE8#	GTIOC0B	SCK1/TXD3/ SMOSI3/ SSDA3/ SDA2-DS/ SSITXD0	EPLSOUT0	SDHI_D3-C/ PIXD3		IRQ7	ADTRG1#
P3		P87		MTIOC4C/ TIOCA2	GTIOC1B	SMOSI10/ SSDA10/ TXD10	EPLSOUT1	SDHI_D2-C/ PIXD2			

Table 1.6 List of Pin and Pin Functions (176-Pin LFBGA) (8/9)

Pin Number	Power Supply Clock System Control	I/O Port	Bus EXDMAC SDRAMC	Timer		Communication		Memory I/F Camera I/F	GLCDC	Interrupt	A/D D/A
				(MTU, TPU, TMR, PPG, RTC, CMTW, POE, CAC)	(GPTW, POEG)	(SCI, RSPI, RIIC, CAN, USB, SSIE)	(ETHERC, PMGI)				
P4		P14		MTIOC3A/ MTCLKA/ TIOCB5/ TCLKA/TMRI2/ PO15	GTETRG D	CTS1#/ RTS1#/ SS1#/CTX1/ USB0_OVRC URA			LCD_CLK- A	IRQ4	
P5	VCC_USB										
P6	VSS_USB										
P7		P57				RXD7/ SMISO7/ SSCL7/ SSLC0-B			LCD_DAT A3-A		
P8		P10	ALE	MTIC5W/ TMRI3						IRQ0	
P9		P52	RD#			RXD2/ SMISO2/ SSCL2/ SSLB3-A					
P10		P83	EDACK1	MTIOC4C	GTIOC0A	SCK10/ SS10#/ CTS10#	ET0_CR_S/ RMII0_CR S_DV		LCD_DAT A8-A		
P11		PC6	D2[A2/D2]/ A22/CS1#	MTIOC3C/ MTCLKA/ TMC12/PO30/ TIC0	GTIOC3B	RXD8/ SMISO8/ SSCL8/ SMISO10/ SSCL10/ RXD10/ MOSIA-A	ET0_ETXD 3	MMC_D6-A	LCD_DAT A10-A	IRQ13	
P12		PC4	A20/CS3#	MTIOC3D/ MTCLKC/ TMC11/PO25/ POE0#	GTETRG C	SCK5/ CTS8#/ SS8#/SS10#/ CTS10#/ RTS10#/ SSLA0-A	ET0_TX_C LK	QMI-A/QIO1- A/SDHI_D1-A/ MMC_D1-A	LCD_DAT A15-A		
P13		PC2	A18	MTIOC4B/ TCLKA/PO21	GTIOC2B	RXD5/ SMISO5/ SSCL5/ SSLA3-A	ET0_RX_D V	SDHI_D3-A/ MMC_CD-A	LCD_DAT A19-A		
P14		P75	CS5#	PO20		SCK11/ RTS11#	ET0_ERXD 0/ RMII0_RX D0	SDHI_D2-A/ MMC_RES#-A	LCD_DAT A20-A		
P15	VCC										
R1		P21		MTIOC1B/ MTIOC4A/ TIOCA3/ TMC10/PO1	GTIOC2A	RXD0/ SMISO0/ SSCL0/ SCL1/ USB0_EXIC EN/ SSILRCK0		SDHI_CLK-C/ PIXD5		IRQ9	
R2		P20		MTIOC1A/ TIOCB3/ TMRI0/PO0		TXD0/ SMOSI0/ SSDA0/ SDA1/ USB0_ID/ SSIRXD0		SDHI_CMD-C/ PIXD4		IRQ8	
R3		P16		MTIOC3C/ MTIOC3D/ TIOCB1/ TCLKC/TMO2/ PO14/ RTCOUT		TXD1/ SMOSI1/ SSDA1/ RXD3/ SMISO3/ SSCL3/ SCL2-DS/ USB0_VBUS EN/ USB0_VBUS / USB0_OVRC URB				IRQ6	ADTRG0#

Table 1.6 List of Pin and Pin Functions (176-Pin LFBGA) (9/9)

Pin Number	Power Supply Clock System Control	I/O Port	Bus EXDMAC SDRAMC	Timer		Communication			Memory I/F Camera I/F	GLCDC	Interrupt	A/D D/A
				(MTU, TPU, TMR, PPG, RTC, CMTW, POE, CAC)	(GPTW, POEG)	(SCI, RSPI, RIIC, CAN, USB, SSIE)	(ETHERC, PMGI)	(QSPI, SDHI, MMCIF, PDC)				
R4		P13	WR2#/BC2#	MTIOC0B/ TIOCA5/ TMO3/PO13	GTADSM1	TXD2/ SMOSI2/ SSDA2/ SDA0[FM+]			LCD_TCO N0-A	IRQ3	ADTRG1#	
R5						USB0_DM						
R6						USB0_DP						
R7	CLKOUT2 5M	P56	EDACK1	MTIOC3C/ TIOCA1		SCK7/ RSPCKC-B			LCD_DAT A4-A			
R8		P11		MTIC5V/ TMCI3		SCK2	EPLSOUT1		LCD_DAT A7-A	IRQ1		
R9		P53*1	BCLK									
R10	VSS											
R11	VCC											
R12		P80	EDREQ0	MTIOC3B/ PO26		SCK10/ RTS10#	ET0_TX_E N/ RMII0_TXD _EN	QIO2-A/ SDHI_WP/ MMC_D2-A	LCD_DAT A14-A			
R13		P76	CS6#	PO22		SMISO11/ SSCL11/ RXD11	ET0_RX_C LK/ REF50CK0	QSSL-A/ SDHI_CMD-A/ MMC_CMD-A	LCD_DAT A18-A			
R14		P74	A20/CS4#	PO19		SS11#/ CTS11#	ET0_ERXD 1/ RMII0_RX D1		LCD_DAT A21-A			
R15		PC1	A17	MTIOC3A/ TCLKD/PO18		SCK5/ SSLA2-A	ET0_ERXD 2		LCD_DAT A22-A	IRQ12		

Note 1. P53 is multiplexed with the BCLK pin function, so cannot be used as an I/O port pin when the external bus is enabled.

1.6.3 176-Pin LQFP

Table 1.7 List of Pin and Pin Functions (176-Pin LQFP) (1/9)

Pin Number	Power Supply Clock System Control	I/O Port	Bus EXDMAC SDRAMC	Timer		Communication		Memory I/F Camera I/F	GLCDC	Interrupt	A/D D/A
				(MTU, TPU, TMR, PPG, RTC, CMTW, POE, CAC)	(GPTW, POEG)	(SCI, RSPI, RIIC, CAN, USB, SSIE)	(ETHERC, PMGI)				
1	AVSS0										
2		P05					SSILRCK1			IRQ13	DA1
3	AVCC1										
4		P03					SSIDATA1			IRQ11	DA0
5	AVSS1										
6		P02			TMCI1		SCK6/ SSIBCK1			IRQ10	AN120
7		P01			TMCIO		RXD6/ SMISO6/ SSCL6/ SSIBCK0			IRQ9	AN119
8		P00			TMRI0		TXD6/ SMOSI6/ SSDA6/ AUDIO_CLK			IRQ8	AN118
9		PF5	WAIT#				SSILRCK0			IRQ4	
10	EMLE										
11		PJ5			POE8#		CTS2#/ RTS2#/ SS2#/ SSIRXD0	EPLSOUT0			
12	VSS										
13		PJ3	EDACK1		MTIOC3C		CTS6#/ RTS6#/ SS6#/ CTS0#/ RTS0#/ SS0#/ SSITXD0	ET0_EXOUT			
14	VCL										
15	VBATT										
16	NC										
17	TRST#	PF4									
18	MD/FINED										
19	XCIN										
20	XCOUT										
21	RES#										
22	XTAL	P37									
23	VSS										
24	EXTAL	P36									
25	VCC										
26	UPSEL	P35								NMI	
27		P34			MTIOC0A/ TMCI3/PO12/ POE10#		SCK6/SCK0	ET0_LINK STA		IRQ4	
28		P33	EDREQ1		MTIOC0D/ TIOC0D/ TMRI3/PO11/ POE4#/ POE11#		RXD6/ SMISO6/ SSCL6/ RXD0/ SMISO0/ SSCL0/ CRX0	PCKO		IRQ3-DS	

Table 1.7 List of Pin and Pin Functions (176-Pin LQFP) (2/9)

Pin Number	Power Supply Clock System Control	I/O Port	Bus EXDMAC SDRAMC	Timer		Communication		Memory I/F Camera I/F	GLCDC	Interrupt	A/D D/A
				(MTU, TPU, TMR, PPG, RTC, CMTW, POE, CAC)	(GPTW, POEG)	(SCI, RSPI, RII, CAN, USB, SSIE)	(ETHERC, PMGI)				
29		P32		MTIOC0C/ TIOCC0/ TMO3/PO10/ RTCIC2/ RTCOU0/ POE0#/ POE10#		TXD6/ SMOSI6/ SSDA6/ TXD0/ SMOSI0/ SSDA0/ CTX0/ USB0_VBUS EN		VSYNC		IRQ2-DS	
30	TMS	PF3									
31	TDI	PF2				RXD1/ SMISO1/ SSCL1					
32		P31		MTIOC4D/ TMCI2/PO9/ RTCIC1		CTS1#/ RTS1#/ SS1#/ SSLB0-A	ET1_MDC/ PMGI1_MD C			IRQ1-DS	
33		P30		MTIOC4B/ TMRI3/PO8/ RTCIC0/ POE8#		RXD1/ SMISO1/ SSCL1/ MISOB-A	ET1_MDIO / PMGI1_MD IO			IRQ0-DS	
34	TCK	PF1				SCK1					
35	TDO	PF0				TXD1/ SMOSI1/ SSDA1					
36		P27	CS7#	MTIOC2B/ TMCI3/PO7		SCK1/ RSPCKB-A	ET1_WOL				
37		P26	CS6#	MTIOC2A/ TMO1/PO6		TXD1/ SMOSI1/ SSDA1/ CTS3#/ RTS3#/ SS3#/ MOSIB-A	ET1_EXOU T				
38	CLKOUT	P25	CS5#/ EDACK1	MTIOC4C/ MTCLKB/ TIOCA4/PO5		RXD3/ SMISO3/ SSCL3/ SSIDA1		SDHI_CD/ HSYNC			ADTRG0#
39	VCC										
40		P24	CS4#/ EDREQ1	MTIOC4A/ MTCLKA/ TIOCB4/ TMRI1/PO4		SCK3/ USB0_VBUS EN/SSIBCK1		SDHI_WP/ PIXCLK			
41	VSS										
42		P23	EDACK0	MTIOC3D/ MTCLKD/ TIOCD3/PO3	GTIOC0A	TXD3/ SMOSI3/ SSDA3/ CTS0#/ RTS0#/ SS0#/ CTX1/ SSIBCK0		SDHI_D1-C/ PIXD7			
43		P22	EDREQ0	MTIOC3B/ MTCLKC/ TIOCC3/ TMO0/PO2	GTIOC1A	SCK0/ USB0_OVRC URB/ AUDIO_CLK		SDHI_D0-C/ PIXD6			
44		P21		MTIOC1B/ MTIOC4A/ TIOCA3/ TMCI0/PO1	GTIOC2A	RXD0/ SMISO0/ SSCL0/ SCL1/ USB0_EXIC EN/ SSILRCK0		SDHI_CLK-C/ PIXD5		IRQ9	

Table 1.7 List of Pin and Pin Functions (176-Pin LFQFP) (3/9)

Pin Number	Power Supply Clock System Control	I/O Port	Bus EXDMAC SDRAMC	Timer		Communication		Memory I/F Camera I/F	GLCDC	Interrupt	A/D D/A
				(MTU, TPU, TMR, PPG, RTC, CMTW, POE, CAC)	(GPTW, POEG)	(SCI, RSPI, RIIC, CAN, USB, SSIE)	(ETHERC, PMGI)				
45		P20		MTIOC1A/ TIOCB3/ TMRI0/PO0		TXD0/ SMOSI0/ SSDA0/ SDA1/ USB0_ID/ SSIRXD0		SDHI_CMD-C/ PIXD4		IRQ8	
46		P17		MTIOC3A/ MTIOC3B/ MTIOC4B/ TIOCB0/ TCLKD/TMO1/ PO15/POE8#	GTIOC0B	SCK1/TXD3/ SMOSI3/ SSDA3/ SDA2-DS/ SSITXD0	EPLSOUT0	SDHI_D3-C/ PIXD3		IRQ7	ADTRG1#
47		P87		MTIOC4C/ TIOCA2	GTIOC1B	SMOSI10/ SSDA10/ TXD10	EPLSOUT1	SDHI_D2-C/ PIXD2			
48		P16		MTIOC3C/ MTIOC3D/ TIOCB1/ TCLKC/TMO2/ PO14/ RTCOUT		TXD1/ SMOSI1/ SSDA1/ RXD3/ SMISO3/ SSCL3/ SCL2-DS/ USB0_VBUS EN/ USB0_VBUS / USB0_OVRC URB			IRQ6	ADTRG0#	
49		P86		MTIOC4D/ TIOCA0	GTIOC2B	SMISO10/ SSCL10/ RXD10		PIXD1			
50		P15		MTIOC0B/ MTCLKB/ TIOCB2/ TCLKB/TMC12/ PO13	GTETRGA	RXD1/ SMISO1/ SSCL1/ SCK3/CRX1- DS/ SSILRCK1		PIXD0		IRQ5	
51		P14		MTIOC3A/ MTCLKA/ TIOCB5/ TCLKA/TMRI2/ PO15	GTETRG D	CTS1#/ RTS1#/ SS1#/CTX1/ USB0_OVRC URA		LCD_CLK- A	IRQ4		
52		P13	WR2#/BC2#	MTIOC0B/ TIOCA5/ TMO3/PO13	GTADSM1	TXD2/ SMOSI2/ SSDA2/ SDA0[FM+]		LCD_TCO N0-A	IRQ3	ADTRG1#	
53		P12	WR3#/BC3#	MTIC5U/ TMC1	GTADSM0	RXD2/ SMISO2/ SSCL2/ SCL0[FM+]		LCD_TCO N1-A	IRQ2		
54	VCC_USB										
55						USB0_DM					
56						USB0_DP					
57	VSS_USB										
58	CLKOUT2 5M	PJ2				TXD8/ SMOSI8/ SSDA8/ SSLC3-B		LCD_TCO N2-A			
59		PJ1		MTIOC6A		RXD8/ SMISO8/ SSCL8/ SSLC2-B	EPLSOUT1	LCD_TCO N3-A			
60		PJ0		MTIOC6B		SCK8/ SSLC1-B	EPLSOUT0	LCD_DAT A0-A			
61		P85		MTIOC6C/ TIOCC0				LCD_DAT A1-A			

Table 1.7 List of Pin and Pin Functions (176-Pin LQFP) (4/9)

Pin Number	Power Supply Clock System Control	I/O Port	Bus EXDMAC SDRAMC	Timer		Communication		Memory I/F Camera I/F	GLCDC	Interrupt	A/D D/A
				(MTU, TPU, TMR, PPG, RTC, CMTW, POE, CAC)	(GPTW, POEG)	(SCI, RSPI, RIIC, CAN, USB, SSIE)	(ETHERC, PMGI)				
62		P84		MTIOC6D			ET1_LINK STA		LCD_DAT A2-A		
63		P57					RXD7/ SMISO7/ SSCL7/ SSLC0-B		LCD_DAT A3-A		
64	CLKOUT2 5M	P56	EDACK1	MTIOC3C/ TIOCA1			SCK7/ RSPCKC-B		LCD_DAT A4-A		
65		P55	D0[A0/D0]/ EDREQ0/ WAIT#	MTIOC4D/ TMO3			TXD7/ SMOSI7/ SSDA7/ MISOC-B/ CRX1	ET0_EXOU T	LCD_DAT A5-A	IRQ10	
66		P54	D1[A1/D1]/ EDACK0/ ALE	MTIOC4B/ TMCI1			CTS2#/ RTS2#/ SS2#/ MOSIC-B/ CTX1	ET0_LINK STA	LCD_DAT A6-A		
67		P11		MTIC5V/ TMCi3			SCK2	EPLSOUT1	LCD_DAT A7-A	IRQ1	
68		P10	ALE	MTIC5W/ TMRI3						IRQ0	
69		P53*1	BCLK								
70		P52	RD#				RXD2/ SMISO2/ SSCL2/ SSLB3-A				
71		P51	WR1#/ BC1#/ WAIT#				SCK2/ SSLB2-A				
72		P50	WR0#/WR#				TXD2/ SMOSI2/ SSDA2/ SSLB1-A				
73	VSS										
74		P83	EDACK1	MTIOC4C	GTIOC0A		SCK10/ SS10#/ CTS10#	ET0_CRS/ RMII0_CR S_DV	LCD_DAT A8-A		
75	VCC										
76	UB	PC7	A23/CS0#	MTIOC3A/ MTCLKB/ TMO2/PO31/ TOC0/ CACREF	GTIOC3A		TXD8/ SMOSI8/ SSDA8/ SMOSH10/ SSDA10/ TXD10/ MISOA-A	ET0_COL	MMC_D7-A	LCD_DAT A9-A	IRQ14
77		PC6	D2[A2/D2]/ A22/CS1#	MTIOC3C/ MTCLKA/ TMC12/PO30/ TIC0	GTIOC3B		RXD8/ SMISO8/ SSCL8/ SMISO10/ SSCL10/ RXD10/ MOSIA-A	ET0_ETXD 3	MMC_D6-A	LCD_DAT A10-A	IRQ13
78		PC5	D3[A3/D3]/ A21/CS2#/ WAIT#	MTIOC3B/ MTCLKD/ TMRI2/PO29	GTIOC1A		SCK8/ RTS8#/ SCK10/ RSPCKA-A	ET0_ETXD 2	MMC_D5-A	LCD_DAT A11-A	
79		P82	EDREQ1	MTIOC4A/ PO28	GTIOC2A		SMOSH10/ SSDA10/ TXD10	ET0_ETXD 1/ RMII0_TXD 1	MMC_D4-A	LCD_DAT A12-A	
80		P81	EDACK0	MTIOC3D/ PO27	GTIOC0B		SMISO10/ SSCL10/ RXD10	ET0_ETXD 0/ RMII0_TXD 0	QIO3-A/ SDHI_CD/ MMC_D3-A	LCD_DAT A13-A	

Table 1.7 List of Pin and Pin Functions (176-Pin LQFP) (5/9)

Pin Number	Power Supply Clock System Control	I/O Port	Bus EXDMAC SDRAMC	Timer		Communication		Memory I/F Camera I/F	GLCDC	Interrupt	A/D D/A
				(MTU, TPU, TMR, PPG, RTC, CMTW, POE, CAC)	(GPTW, POEG)	(SCI, RSPI, RIIC, CAN, USB, SSIE)	(ETHERC, PMGI)				
81		P80	EDREQ0	MTIOC3B/PO26		SCK10/RTS10#	ET0_TX_EN/RMII0_TXD_EN	QIO2-A/SDHI_WP/MMC_D2-A	LCD_DAT A14-A		
82		PC4	A20/CS3#	MTIOC3D/MTCLKC/TMC1/PO25/POE0#	GTETRC	SCK5/CTS8#/SS8#/SS10#/CTS10#/RTS10#/SSLA0-A	ET0_TX_CLK	QMI-A/QIO1-A/SDHI_D1-A/MMC_D1-A	LCD_DAT A15-A		
83		PC3	A19	MTIOC4D/TCLKB/PO24	GTIOC1B	TXD5/SMOSI5/SSDA5	ET0_TX_ER	QMO-A/QIO0-A/SDHI_D0-A/MMC_D0-A	LCD_DAT A16-A		
84		P77	CS7#	PO23		SMOSI11/SSDA11/TXD11	ET0_RX_ER/RMII0_RX_ER	QSPCLK-A/SDHI_CLK-A/MMC_CLK-A	LCD_DAT A17-A		
85		P76	CS6#	PO22		SMISO11/SSCL11/RXD11	ET0_RX_CLK/REF50CK0	QSSL-A/SDHI_CMD-A/MMC_CMD-A	LCD_DAT A18-A		
86		PC2	A18	MTIOC4B/TCLKA/PO21	GTIOC2B	RXD5/SMISO5/SSCL5/SSLA3-A	ET0_RX_DV	SDHI_D3-A/MMC_CD-A	LCD_DAT A19-A		
87		P75	CS5#	PO20		SCK11/RTS11#	ET0_ERXD0/RMII0_RXD0	SDHI_D2-A/MMC_RES#-A	LCD_DAT A20-A		
88		P74	A20/CS4#	PO19		SS11#/CTS11#	ET0_ERXD1/RMII0_RXD1		LCD_DAT A21-A		
89		PC1	A17	MTIOC3A/TCLKD/PO18		SCK5/SSLA2-A	ET0_ERXD2		LCD_DAT A22-A	IRQ12	
90	VCC										
91		PC0	A16	MTIOC3C/TCLKC/PO17		CTS5#/RTS5#/SS5#/SSLA1-A	ET0_ERXD3			IRQ14	
92	VSS										
93		P73	CS3#	PO16			ET0_WOL		LCD_EXT CLK-A		
94		PB7	A15	MTIOC3B/TIOCB5/PO31		TXD9/SMOSI9/SSDA9/SMOSI11/SSDA11/TXD11	ET0_CRS/RMII0_CRS_DV				
95		PB6	A14	MTIOC3D/TIOCA5/PO30		RXD9/SMISO9/SSCL9/SMISO11/SSCL11/RXD11	ET0_ETXD1/RMII0_TXD1				
96		PB5	A13	MTIOC2A/MTIOC1B/TIOCB4/TMRI1/PO29/POE4#		SCK9/RTS9#/SCK11	ET0_ETXD0/RMII0_TXD0		LCD_CLK-B		
97		PB4	A12	TIOCA4/PO28		CTS9#/SS9#/SS11#/CTS11#/RTS11#	ET0_TX_EN/RMII0_TXD_EN		LCD_TCO N0-B		

Table 1.7 List of Pin and Pin Functions (176-Pin LQFP) (6/9)

Pin Number	Power Supply Clock System Control	I/O Port	Bus EXDMAC SDRAMC	Timer		Communication		Memory I/F Camera I/F	GLCDC	Interrupt	A/D D/A
				(MTU, TPU, TMR, PPG, RTC, CMTW, POE, CAC)	(GPTW, POEG)	(SCI, RSPI, RIIC, CAN, USB, SSIE)	(ETHERC, PMGI)				
176-Pin LQFP											
98		PB3	A11	MTIOC0A/ MTIOC4A/ TIOCD3/ TCLKD/TMO0/ PO27/POE11#		SCK4/SCK6	ET0_RX_E R/ RMII0_RX_ ER		LCD_TCO N1-B		
99		PB2	A10	TIOCC3/ TCLKC/PO26		CTS4#/ RTS4#/ SS4#/ CTS6#/ RTS6#/SS6#	ET0_RX_C LK/ REF50CK0		LCD_TCO N2-B		
100		PB1	A9	MTIOC0C/ MTIOC4C/ TIOCB3/ TMCI0/PO25		TXD4/ SMOSI4/ SSDA4/ TXD6/ SMOSI6/ SSDA6	ET0_ERXD 0/ RMII0_RX D0		LCD_TCO N3-B	IRQ4-DS	
101		P72	A19/CS2#				ET0_MDC/ PMGIO_MD C		LCD_DAT A23-A		
102		P71	A18/CS1#				ET0_MDIO / PMGIO_MD IO				
103	VCC										
104		PB0	A8	MTIC5W/ TIOCA3/PO24		RXD4/ SMISO4/ SSCL4/ RXD6/ SMISO6/ SSCL6	ET0_ERXD 1/ RMII0_RX D1		LCD_DAT A0-B	IRQ12	
105	VSS										
106		PA7	A7	TIOCB2/PO23		MISOA-B	ET0_WOL		LCD_DAT A1-B		
107		PA6	A6	MTIC5V/ MTCLKB/ TIOCA2/ TMCI3/PO22/ POE10#	GTETRGB	CTS5#/ RTS5#/ SS5#/ MOSIA-B	ET0_EXOU T		LCD_DAT A2-B		
108		PA5	A5	MTIOC6B/ TIOCB1/PO21	GTIOC0A	RSPCKA-B	ET0_LINK STA		LCD_DAT A3-B		
109		PA4	A4	MTIC5U/ MTCLKA/ TIOCA1/ TMRI0/PO20		TXD5/ SMOSI5/ SSDA5/ SSLA0-B	ET0_MDC/ PMGIO_MD C		LCD_DAT A4-B	IRQ5-DS	
110		PA3	A3	MTIOC0D/ MTCLKD/ TIOCD0/ TCLKB/PO19		RXD5/ SMISO5/ SSCL5	ET0_MDIO / PMGIO_MD IO		LCD_DAT A5-B	IRQ6-DS	
111	TRDATA3	PG7	D31				ET1_TX_E R				
112		PA2	A2	MTIOC7A/ PO18	GTIOC1A	RXD5/ SMISO5/ SSCL5/ SSLA3-B			LCD_DAT A6-B		
113	TRDATA2	PG6	D30				ET1_ETXD 3				
114		PA1	DQM3/A1	MTIOC0B/ MTCLKC/ MTIOC7B/ TIOCB0/PO17	GTIOC2A	SCK5/ SSLA2-B	ET0_WOL		LCD_DAT A7-B	IRQ11	
115	VCC										
116	TRCLK	PG5	D29				ET1_ETXD 2				
117	VSS										

Table 1.7 List of Pin and Pin Functions (176-Pin LQFP) (7/9)

Pin Number	Power Supply Clock System Control	I/O Port	Bus EXDMAC SDRAMC	Timer		Communication		Memory I/F Camera I/F	GLCDC	Interrupt	A/D D/A
				(MTU, TPU, TMR, PPG, RTC, CMTW, POE, CAC)	(GPTW, POEG)	(SCI, RSPI, RIIC, CAN, USB, SSIE)	(ETHERC, PMGI)				
118		PA0	DQM2/BC0#/A0	MTIOC4A/MTIOC6D/TIOCA0/PO16/CACREF	GTIOC0B	SSLA1-B	ET0_TX_EN/RMII0_TXD_EN		LCD_DAT A8-B		
119	TRSYNC	PG4	D28				ET1_ETXD1/RMII1_TXD1				
120		P67	DQM1/CS7#	MTIOC7C	GTIOC1B	CRX2	EPLSOUT1			IRQ15	
121	TRDATA1	PG3	D27				ET1_ETXD0/RMII1_TXD0				
122		P66	DQM0/CS6#	MTIOC7D	GTIOC2B	CTX2					
123	TRDATA0	PG2	D26				ET1_TX_C LK				
124		P65	CKE/CS5#								
125		PE7	D15[A15/D15]/D7[A7/D7]	MTIOC6A/TOC1	GTIOC3A	MISOB-B		SDHI_WP/MMC_RES#-B	LCD_DAT A9-B	IRQ7	AN105
126		PE6	D14[A14/D14]/D6[A6/D6]	MTIOC6C/TIC1	GTIOC3B	MOSIB-B		SDHI_CD/MMC_CD-B	LCD_DAT A10-B	IRQ6	AN104
127	VCC										
128		P70	SDCLK								
129	VSS										
130		PE5	D13[A13/D13]/D5[A5/D5]	MTIOC4C/MTIOC2B	GTIOC0A	RSPCKB-B	ET0_RX_C LK/REF50CK0		LCD_DAT A11-B	IRQ5	AN103
131		PE4	D12[A12/D12]/D4[A4/D4]	MTIOC4D/MTIOC1A/PO28	GTIOC1A	SSLB0-B	ET0_ERXD2		LCD_DAT A12-B		AN102
132		PE3	D11[A11/D11]/D3[A3/D3]	MTIOC4B/PO26/TOC3/POE8#	GTIOC2A	CTS12#/RTS12#/SS12#	ET0_ERXD3	MMC_D7-B	LCD_DAT A13-B		AN101
133		PE2	D10[A10/D10]/D2[A2/D2]	MTIOC4A/PO23/TIC3	GTIOC0B	RXD12/SMISO12/SSCL12/RXDX12/SSLB3-B		MMC_D6-B	LCD_DAT A14-B	IRQ7-DS	AN100
134		PE1	D9[A9/D9]/D1[A1/D1]	MTIOC4C/MTIOC3B/PO18	GTIOC1B	TXD12/SMOSI12/SSDA12/TXDX12/SIOX12/SSLB2-B		MMC_D5-B	LCD_DAT A15-B		ANEX1
135		PE0	D8[A8/D8]/D0[A0/D0]	MTIOC3D	GTIOC2B	SCK12/SSLB1-B		MMC_D4-B	LCD_DAT A16-B		ANEX0
136		P64	WE#/D3[A3/D3]/CS4#				ET1_ETXD0/RMII1_TXD0				
137		P63	CAS#/D2[A2/D2]/CS3#				ET1_ETXD1/RMII1_TXD1				
138		P62	RAS#/D1[A1/D1]/CS2#				ET1_ERXD0/RMII1_RXD0				

Table 1.7 List of Pin and Pin Functions (176-Pin LQFP) (8/9)

Pin Number	Power Supply Clock System Control	I/O Port	Bus EXDMAC SDRAMC	Timer		Communication		Memory I/F Camera I/F	GLCDC	Interrupt	A/D D/A
				(MTU, TPU, TMR, PPG, RTC, CMTW, POE, CAC)	(GPTW, POEG)	(SCI, RSPI, RIIC, CAN, USB, SSIE)	(ETHERC, PMGI)				
176-Pin LQFP											
139		P61	SDCS#/ D0[A0/D0]/ CS1#				ET1_ERXD 1/ RMII1_RX D1				
140	VSS										
141		P60	CS0#				ET1_TX_E N/ RMII1_TXD _EN				
142	VCC										
143		PD7	D7[A7/D7]	MTIC5U/ POE0#		SSLC3-A	ET1_RX_E R/ RMII1_RX_ ER	QMI-B/QIO1- B/SDHI_D1-B/ MMC_D1-B	LCD_DAT A17-B	IRQ7	AN107
144	TRDATA7	PG1	D25				ET1_RX_E R/ RMII1_RX_ ER				
145		PD6	D6[A6/D6]	MTIC5V/ MTIOC8A/ POE4#		SSLC2-A	ET1_RX_C LK/ REF50CK1	QMO-B/QIO0- B/SDHI_D0-B/ MMC_D0-B	LCD_DAT A18-B	IRQ6	AN106
146	TRDATA6	PG0	D24				ET1_RX_C LK/ REF50CK1				
147		PD5	D5[A5/D5]	MTIC5W/ MTIOC8C/ MTCLKA/ POE10#		SSLC1-A	ET1_MDC/ PMGI1_MD C	QSPCLK-B/ SDHI_CLK-B/ MMC_CLK-B	LCD_DAT A19-B	IRQ5	AN113
148		PD4	D4[A4/D4]	MTIOC8B/ POE11#		SSLC0-A	ET1_MDIO / PMGI1_MD IO	QSSL-B/ SDHI_CMD-B/ MMC_CMD-B	LCD_DAT A20-B	IRQ4	AN112
149	TRSYNC1	P97	D23/A23				ET1_ERXD 3				
150		PD3	D3[A3/D3]	MTIOC8D/ TOC2/POE8#	GTIOC0A	RSPCKC-A	ET1_WOL	QIO3-B/ SDHI_D3-B/ MMC_D3-B	LCD_DAT A21-B	IRQ3	AN111
151	VSS										
152	TRDATA5	P96	D22/A22				ET1_ERXD 2				
153	VCC										
154		PD2	D2[A2/D2]	MTIOC4D/ TIC2	GTIOC0B	MISOC-A/ CRX0	ET1_EXOU T	QIO2-B/ SDHI_D2-B/ MMC_D2-B	LCD_DAT A22-B	IRQ2	AN110
155	TRDATA4	P95	D21/A21				ET1_ERXD 1/ RMII1_RX D1				
156		PD1	D1[A1/D1]	MTIOC4B/ POE0#	GTIOC1A	MOSIC-A/ CTX0			LCD_DAT A23-B	IRQ1	AN109
157		P94	D20/A20				ET1_ERXD 0/ RMII1_RX D0				
158		PD0	D0[A0/D0]	POE4#	GTIOC1B				LCD_EXT CLK-B	IRQ0	AN108
159		P93	D19/A19	POE0#		CTS7#/ RTS7#/SS7#	ET1_LINK STA				AN117
160		P92	D18/A18	POE4#		RXD7/ SMISO7/ SSCL7	ET1_CRS/ RMII1_CR S_DV				AN116
161		P91	D17/A17			SCK7	ET1_COL				AN115

Table 1.7 List of Pin and Pin Functions (176-Pin LQFP) (9/9)

Pin Number	Power Supply Clock System Control	I/O Port	Bus EXDMAC SDRAMC	Timer		Communication		Memory I/F Camera I/F	GLCDC	Interrupt	A/D D/A
				(MTU, TPU, TMR, PPG, RTC, CMTW, POE, CAC)	(GPTW, POEG)	(SCI, RSPI, RIIC, CAN, USB, SSIE)	(ETHERC, PMGI)				
162	VSS										
163		P90	D16/A16			TXD7/ SMOSI7/ SSDA7	ET1_RX_D V				AN114
164	VCC										
165		P47								IRQ15-DS	AN007
166		P46								IRQ14-DS	AN006
167		P45								IRQ13-DS	AN005
168		P44								IRQ12-DS	AN004
169		P43								IRQ11-DS	AN003
170		P42								IRQ10-DS	AN002
171		P41								IRQ9-DS	AN001
172	VREFL0										
173		P40								IRQ8-DS	AN000
174	VREFH0										
175	AVCC0										
176		P07								IRQ15	ADTRG0#

Note 1. P53 is multiplexed with the BCLK pin function, so cannot be used as an I/O port pin when the external bus is enabled.

1.6.4 145-Pin TFLGA

Table 1.8 List of Pin and Pin Functions (145-Pin TFLGA) (1/7)

Pin Number	Power Supply Clock System Control	I/O Port	Bus EXDMAC SDRAMC	Timer		Communication		Memory I/F Camera I/F	GLCDC	Interrupt	A/D D/A
				(MTU, TPU, TMR, PPG, RTC, CMTW, POE, CAC)	(GPTW, POEG)	(SCI, RSPI, RIIC, CAN, USB, SSIE)	(ETHERC, PMGI)				
A1	AVSS0										
A2		P07								IRQ15	ADTRG0#
A3		P40								IRQ8-DS	AN000
A4		P42								IRQ10-DS	AN002
A5		P45								IRQ13-DS	AN005
A6		P90	A16				TXD7/ SMOSI7/ SSDA7				AN114
A7		P92	A18	POE4#			RXD7/ SMISO7/ SSCL7	RMII1_CR S_DV			AN116
A8		PD2	D2[A2/D2]	MTIOC4D/ TIC2	GTIOC0B	MISOC-A/ CRX0	ET1_EXOU T	QIO2-B/ SDHI_D2-B/ MMC_D2-B	LCD_DAT A22-B	IRQ2	AN110
A9		PD6	D6[A6/D6]	MTIC5V/ MTIOC8A/ POE4#		SSLC2-A	REF50CK1	QMO-B/QIO0- B/SDHI_D0-B/ MMC_D0-B	LCD_DAT A18-B	IRQ6	AN106
A10	VSS										
A11		P62	RAS#/ D1[A1/D1]/ CS2#					RMII1_RX D0			
A12		PE1	D9[A9/D9]/ D1[A1/D1]	MTIOC4C/ MTIOC3B/ PO18	GTIOC1B	TXD12/ SMOSI12/ SSDA12/ TXDX12/ SIOX12/ SSLB2-B		MMC_D5-B	LCD_DAT A15-B		ANEX1
A13		PE3	D11[A11/ D11]/D3[A3/ D3]	MTIOC4B/ PO26/TOC3/ POE8#	GTIOC2A	CTS12#/ RTS12#/ SS12#	ET0_ERXD 3	MMC_D7-B	LCD_DAT A13-B		AN101
B1	AVCC1										
B2	AVCC0										
B3		P05					SSILRCK1			IRQ13	DA1
B4	VREFL0										
B5		P43								IRQ11-DS	AN003
B6		P47								IRQ15-DS	AN007
B7		P91	A17				SCK7				AN115
B8		PD0	D0[A0/D0]	POE4#	GTIOC1B				LCD_EXT CLK-B	IRQ0	AN108
B9		PD4	D4[A4/D4]	MTIOC8B/ POE11#		SSLC0-A	ET1_MDIO / PMGI1_MD IO	QSSL-B/ SDHI_CMD-B/ MMC_CMD-B	LCD_DAT A20-B	IRQ4	AN112
B10	VCC										
B11		P61	SDCS#/ D0[A0/D0]/ CS1#					RMII1_RX D1			
B12		PE2	D10[A10/ D10]/D2[A2/ D2]	MTIOC4A/ PO23/TIC3	GTIOC0B	RXD12/ SMISO12/ SSCL12/ RXDX12/ SSLB3-B		MMC_D6-B	LCD_DAT A14-B	IRQ7-DS	AN100
B13		PE4	D12[A12/ D12]/D4[A4/ D4]	MTIOC4D/ MTIOC1A/ PO28	GTIOC1A	SSLB0-B	ET0_ERXD 2		LCD_DAT A12-B		AN102
C1	AVSS1										

Table 1.8 List of Pin and Pin Functions (145-Pin TFLGA) (2/7)

Pin Number	Power Supply Clock System Control	I/O Port	Bus EXDMAC SDRAMC	Timer		Communication			Memory I/F Camera I/F	GLCDC	Interrupt	A/D D/A
				(MTU, TPU, TMR, PPG, RTC, CMTW, POE, CAC)	(GPTW, POEG)	(SCI, RSPI, RIIC, CAN, USB, SSIE)	(ETHERC, PMGI)	(QSPI, SDHI, MMCIF, PDC)				
145-Pin TFLGA												
C2		P02		TMCI1		SCK6/SSIBCK1					IRQ10	AN120
C3	VREFH0											
C4		P41									IRQ9-DS	AN001
C5		P46									IRQ14-DS	AN006
C6	VSS											
C7		PD1	D1[A1/D1]	MTIOC4B/POE0#	GTIOC1A	MOSIC-A/CTX0			LCD_DAT A23-B		IRQ1	AN109
C8		PD3	D3[A3/D3]	MTIOC8D/TOC2/POE8#	GTIOC0A	RSPCKC-A	ET1_WOL	QIO3-B/SDHI_D3-B/MMC_D3-B	LCD_DAT A21-B		IRQ3	AN111
C9		PD7	D7[A7/D7]	MTIC5U/POE0#		SSLC3-A	RMII1_RX_ER	QMI-B/QIO1-B/SDHI_D1-B/MMC_D1-B	LCD_DAT A17-B		IRQ7	AN107
C10		P63	CAS#/D2[A2/D2]/CS3#				RMII1_TXD1					
C11		PE0	D8[A8/D8]/D0[A0/D0]	MTIOC3D	GTIOC2B	SCK12/SSLB1-B		MMC_D4-B	LCD_DAT A16-B			ANEX0
C12		P70	SDCLK									
C13	VSS											
D1		P00		TMRI0		TXD6/SMOSI6/SSDA6/AUDIO_CLK					IRQ8	AN118
D2		PF5	WAIT#			SSILRCK0					IRQ4	
D3		P03				SSIDATA1					IRQ11	DA0
D4		P01		TMCI0		RXD6/SMISO6/SSCL6/SSIBCK0					IRQ9	AN119
D5	VCC											
D6		P93	A19	POE0#		CTS7#/RTS7#/SS7#	ET1_LINK STA					AN117
D7		PD5	D5[A5/D5]	MTIC5W/MTIOC8C/MTCLKA/POE10#		SSLC1-A	ET1_MDC/PMGI1_MD C	QSPCLK-B/SDHI_CLK-B/MMC_CLK-B	LCD_DAT A19-B		IRQ5	AN113
D8		P60	CS0#				RMII1_TXD_EN					
D9		P64	WE#/D3[A3/D3]/CS4#				RMII1_TXD0					
D10		PE7	D15[A15/D15]/D7[A7/D7]	MTIOC6A/TOC1	GTIOC3A	MISOB-B		SDHI_WP/MMC_RES#-B	LCD_DAT A9-B		IRQ7	AN105
D11	VCC											
D12		PE5	D13[A13/D13]/D5[A5/D5]	MTIOC4C/MTIOC2B	GTIOC0A	RSPCKB-B	ET0_RX_C LK/REF50CK0		LCD_DAT A11-B		IRQ5	AN103
D13		PE6	D14[A14/D14]/D6[A6/D6]	MTIOC6C/TIC1	GTIOC3B	MOSIB-B		SDHI_CD/MMC_CD-B	LCD_DAT A10-B		IRQ6	AN104
E1	VSS											
E2	VCL											
E3		PJ5		POE8#		CTS2#/RTS2#/SS2#/SSIRXD0	EPLSOUT0					
E4	EMLE											

Table 1.8 List of Pin and Pin Functions (145-Pin TFLGA) (3/7)

Pin Number	Power Supply Clock System Control	I/O Port	Bus EXDMAC SDRAMC	Timer		Communication		Memory I/F Camera I/F	GLCDC	Interrupt	A/D D/A
				(MTU, TPU, TMR, PPG, RTC, CMTW, POE, CAC)	(GPTW, POEG)	(SCI, RSPI, RIIC, CAN, USB, SSIE)	(ETHERC, PMGI)				
145-Pin TFLGA											
E5		P44								IRQ12-DS	AN004
E10		PA0	BC0#/A0	MTIOC4A/ MTIOC6D/ TIOCA0/PO16/ CACREF	GTIOC0B	SSLA1-B	ET0_TX_E N/ RMII0_TXD _EN		LCD_DAT A8-B		
E11		P66	DQM0/ CS6#	MTIOC7D	GTIOC2B	CTX2					
E12		P65	CKE/CS5#								
E13		P67	DQM1/ CS7#	MTIOC7C	GTIOC1B	CRX2	EPLSOUT1			IRQ15	
F1	XCIN										
F2	XCOUT										
F3		PJ3	EDACK1	MTIOC3C		CTS6#/ RTS6#/ SS6#/ CTS0#/ RTS0#/ SS0#/ SSITXD0	ET0_EXOU T				
F4	VBATT										
F10		PA3	A3	MTIOC0D/ MTCLKD/ TIOCD0/ TCLKB/PO19		RXD5/ SMISO5/ SSCL5	ET0_MDIO / PMGIO_MD IO		LCD_DAT A5-B	IRQ6-DS	
F11	VSS										
F12		PA1	A1	MTIOC0B/ MTCLKC/ MTIOC7B/ TIOCB0/PO17	GTIOC2A	SCK5/ SSLA2-B	ET0_WOL		LCD_DAT A7-B	IRQ11	
F13		PA2	A2	MTIOC7A/ PO18	GTIOC1A	RXD5/ SMISO5/ SSCL5/ SSLA3-B			LCD_DAT A6-B		
G1	XTAL	P37									
G2	RES#										
G3	MD/FINED										
G4	BSCANP										
G10		PA5	A5	MTIOC6B/ TIOCB1/PO21	GTIOC0A	RSPCKA-B	ET0_LINK STA		LCD_DAT A3-B		
G11		PA6	A6	MTIC5V/ MTCLKB/ TIOCA2/ TMC13/PO22/ POE10#	GTETRGB	CTS5#/ RTS5#/ SS5#/ MOSIA-B	ET0_EXOU T		LCD_DAT A2-B		
G12	VCC										
G13		PA4	A4	MTIC5U/ MTCLKA/ TIOCA1/ TMRI0/PO20		TXD5/ SMOSI5/ SSDA5/ SSLA0-B	ET0_MDC/ PMGIO_MD C		LCD_DAT A4-B	IRQ5-DS	
H1	EXTAL	P36									
H2	VCC										
H3	VSS										
H4	UPSEL	P35								NMI	
H10		P72	A19/CS2#				ET0_MDC/ PMGIO_MD C				
H11		P71	A18/CS1#				ET0_MDIO / PMGIO_MD IO				

Table 1.8 List of Pin and Pin Functions (145-Pin TFLGA) (4/7)

Pin Number	Power Supply Clock System Control	I/O Port	Bus EXDMAC SDRAMC	Timer		Communication		Memory I/F Camera I/F	GLCDC	Interrupt	A/D D/A
				(MTU, TPU, TMR, PPG, RTC, CMTW, POE, CAC)	(GPTW, POEG)	(SCI, RSPI, RIIC, CAN, USB, SSIE)	(ETHERC, PMGI)				
H12		PB0	A8	MTIC5W/ TIOCA3/PO24		RXD4/ SMISO4/ SSCL4/ RXD6/ SMISO6/ SSCL6	ET0_ERXD 1/ RMII0_RX D1		LCD_DAT A0-B	IRQ12	
H13		PA7	A7	TIOCB2/PO23		MISOA-B	ET0_WOL		LCD_DAT A1-B		
J1	TRST#	P34		MTIOC0A/ TMCI3/PO12/ POE10#		SCK6/SCK0	ET0_LINK STA			IRQ4	
J2		P33	EDREQ1	MTIOC0D/ TIOCD0/ TMRI3/PO11/ POE4#/ POE11#		RXD6/ SMISO6/ SSCL6/ RXD0/ SMISO0/ SSCL0/ CRX0		PCKO		IRQ3-DS	
J3		P32		MTIOC0C/ TIOCC0/ TMO3/PO10/ RTCIC2/ RTCOU/ POE0#/ POE10#		TXD6/ SMOSI6/ SSDA6/ TXD0/ SMOSI0/ SSDA0/ CTX0/ USB0_VBUS EN		VSYNC		IRQ2-DS	
J4	TDI	P30		MTIOC4B/ TMRI3/PO8/ RTCIC0/ POE8#		RXD1/ SMISO1/ SSCL1/ MISOB-A	ET1_MDIO / PMGI1_MD IO			IRQ0-DS	
J10		PB3	A11	MTIOC0A/ MTIOC4A/ TIOCD3/ TCLKD/TMO0/ PO27/POE11#		SCK4/SCK6	ET0_RX_E R/ RMII0_RX_ ER		LCD_TCO N1-B		
J11		PB4	A12	TIOCA4/PO28		CTS9#/ SS9#/SS11#/ CTS11#/ RTS11#	ET0_TX_E N/ RMII0_TXD _EN		LCD_TCO N0-B		
J12		PB2	A10	TIOCC3/ TCLKC/PO26		CTS4#/ RTS4#/ SS4#/ CTS6#/ RTS6#/SS6#	ET0_RX_C LK/ REF50CK0		LCD_TCO N2-B		
J13		PB1	A9	MTIOC0C/ MTIOC4C/ TIOCB3/ TMCI0/PO25		TXD4/ SMOSI4/ SSDA4/ TXD6/ SMOSI6/ SSDA6	ET0_ERXD 0/ RMII0_RX D0		LCD_TCO N3-B	IRQ4-DS	
K1	TCK	P27	CS7#	MTIOC2B/ TMCI3/PO7		SCK1/ RSPCKB-A	ET1_WOL				
K2	TDO	P26	CS6#	MTIOC2A/ TMO1/PO6		TXD1/ SMOSI1/ SSDA1/ CTS3#/ RTS3#/ SS3#/ MOSIB-A	ET1_EXOU T				
K3	TMS	P31		MTIOC4D/ TMCI2/PO9/ RTCIC1		CTS1#/ RTS1#/ SS1#/ SSLB0-A	ET1_MDC/ PMGI1_MD C			IRQ1-DS	
K4		P15		MTIOC0B/ MTCLKB/ TIOCB2/ TCLKB/TMCI2/ PO13	GTETRGA	RXD1/ SMISO1/ SSCL1/ SCK3/CRX1- DS/ SSILRCK1		PIXD0		IRQ5	

Table 1.8 List of Pin and Pin Functions (145-Pin TFLGA) (5/7)

Pin Number	Power Supply Clock System Control	I/O Port	Bus EXDMAC SDRAMC	Timer		Communication		Memory I/F Camera I/F	GLCDC	Interrupt	A/D D/A
				(MTU, TPU, TMR, PPG, RTC, CMTW, POE, CAC)	(GPTW, POEG)	(SCI, RSPI, RIIC, CAN, USB, SSIE)	(ETHERC, PMGI)				
145-Pin TFLGA											
K5	TRDATA2	P54	ALE/ D1[A1/D1]/ EDACK0	MTIOC4B/ TMCI1		CTS2#/ RTS2#/ SS2#/CTX1	ET0_LINK STA				
K6		P53*1	BCLK								
K7		P51	WR1#/ BC1#/ WAIT#			SCK2/ SSLB2-A					
K8	VCC										
K9	TRDATA0	P80	EDREQ0	MTIOC3B/ PO26		SCK10/ RTS10#	ET0_TX_E N/ RMII0_TXD _EN	QIO2-A/ SDHI_WP/ MMC_D2-A			
K10	TRDATA6	P76	CS6#	PO22		SMISO11/ SSCL11/ RXD11	ET0_RX_C LK/ REF50CK0	QSSL-A/ SDHI_CMD-A/ MMC_CMD-A			
K11		PB7	A15	MTIOC3B/ TIOCB5/PO31		TXD9/ SMOSI9/ SSDA9/ SMOSI11/ SSDA11/ TXD11	ET0_CRS/ RMII0_CR S_DV				
K12		PB6	A14	MTIOC3D/ TIOCA5/PO30		RXD9/ SMISO9/ SSCL9/ SMISO11/ SSCL11/ RXD11	ET0_ETXD 1/ RMII0_TXD 1				
K13		PB5	A13	MTIOC2A/ MTIOC1B/ TIOCB4/ TMRI1/PO29/ POE4#		SCK9/ RTS9#/ SCK11	ET0_ETXD 0/ RMII0_TXD 0		LCD_CLK- B		
L1	CLKOUT	P25	CS5#/ EDACK1	MTIOC4C/ MTCLKB/ TIOCA4/PO5		RXD3/ SMISO3/ SSCL3/ SSIDATA1		SDHI_CD/ HSYNC			ADTRG0#
L2		P23	EDACK0	MTIOC3D/ MTCLKD/ TIOCD3/PO3	GTIOC0A	TXD3/ SMOSI3/ SSDA3/ CTS0#/ RTS0#/ SS0#/CTX1/ SSIBCK0		SDHI_D1-C/ PIXD7			
L3		P16		MTIOC3C/ MTIOC3D/ TIOCB1/ TCLKC/TMO2/ PO14/ RTCOUT		TXD1/ SMOSI1/ SSDA1/ RXD3/ SMISO3/ SSCL3/ SCL2-DS/ USB0_VBUS EN/ USB0_VBUS / USB0_OVRC URB				IRQ6	ADTRG0#
L4		P24	CS4#/ EDREQ1	MTIOC4A/ MTCLKA/ TIOCB4/ TMRI1/PO4		SCK3/ USB0_VBUS EN/SSIBCK1		SDHI_WP/ PIXCLK			
L5		P13		MTIOC0B/ TIOCA5/ TMO3/PO13	GTADSM1	TXD2/ SMOSI2/ SSDA2/ SDA0[FM+]				IRQ3	ADTRG1#
L6	CLKOUT2 5M	P56	EDACK1	MTIOC3C/ TIOCA1		SCK7					

Table 1.8 List of Pin and Pin Functions (145-Pin TFLGA) (6/7)

Pin Number	Power Supply Clock System Control	I/O Port	Bus EXDMAC SDRAMC	Timer		Communication		Memory I/F Camera I/F	GLCDC	Interrupt	A/D D/A
				(MTU, TPU, TMR, PPG, RTC, CMTW, POE, CAC)	(GPTW, POEG)	(SCI, RSPI, RIIC, CAN, USB, SSIE)	(ETHERC, PMGI)				
L7		P52	RD#			RXD2/ SMISO2/ SSCL2/ SSLB3-A					
L8	TRCLK	P83	EDACK1	MTIOC4C	GTIOC0A	SCK10/ SS10#/ CTS10#	ET0_CRS/ RMII0_CR S_DV				
L9		PC5	D3[A3/D3]/ A21/CS2#/ WAIT#	MTIOC3B/ MTCLKD/ TMR12/PO29	GTIOC1A	SCK8/ RTS8#/ SCK10/ RSPCKA-A	ET0_ETXD 2	MMC_D5-A			
L10		PC4	A20/CS3#	MTIOC3D/ MTCLKC/ TMC11/PO25/ POE0#	GTETRG C	SCK5/ CTS8#/ SS8#/SS10#/ CTS10#/ RTS10#/ SSLA0-A	ET0_TX_C LK	QMI-A/ QIO1-A/ SDHI_D1-A/ MMC_D1-A			
L11		PC2	A18	MTIOC4B/ TCLKA/PO21	GTIOC2B	RXD5/ SMISO5/ SSCL5/ SSLA3-A	ET0_RX_D V	SDHI_D3-A/ MMC_CD-A			
L12	TRDATA4	P73	CS3#	PO16			ET0_WOL				
L13	VSS										
M1		P22	EDREQ0	MTIOC3B/ MTCLKC/ TIOCC3/ TMO0/PO2	GTIOC1A	SCK0/ USB0_OVRC URB/ AUDIO_CLK		SDHI_D0-C/ PIXD6			
M2		P17		MTIOC3A/ MTIOC3B/ MTIOC4B/ TIOCB0/ TCLKD/TMO1/ PO15/POE8#	GTIOC0B	SCK1/TXD3/ SMOSI3/ SSDA3/ SDA2-DS/ SSITXD0	EPLSOUT0	SDHL_D3-C/ PIXD3		IRQ7	ADTRG1#
M3		P86		MTIOC4D/ TIOCA0	GTIOC2B	SMISO10/ SSCL10/ RXD10		PIXD1			
M4		P12		TMC11	GTADSM0	RXD2/ SMISO2/ SSCL2/ SCL0[FM+]				IRQ2	
M5	VCC_USB										
M6	VSS_USB										
M7		P50	WR0#/WR#			TXD2/ SMOSI2/ SSDA2/ SSLB1-A					
M8		PC6	D2[A2/D2]/ A22/CS1#	MTIOC3C/ MTCLKA/ TMC12/PO30/ TIC0	GTIOC3B	RXD8/ SMISO8/ SSCL8/ SMISO10/ SSCL10/ RXD10/ MOSIA-A	ET0_ETXD 3	MMC_D6-A		IRQ13	
M9	TRDATA1	P81	EDACK0	MTIOC3D/ PO27	GTIOC0B	SMISO10/ SSCL10/ RXD10	ET0_ETXD 0/ RMII0_TXD 0	QIO3-A/ SDHI_CD/ MMC_D3-A			
M10	TRDATA7	P77	CS7#	PO23		SMOSI11/ SSDA11/ TXD11	ET0_RX_E R/ RMII0_RX_ ER	QSPCLK-A/ SDHI_CLK-A/ MMC_CLK-A			
M11		PC0	A16	MTIOC3C/ TCLKC/PO17		CTS5#/ RTS5#/ SS5#/ SSLA1-A	ET0_ERXD 3			IRQ14	

Table 1.8 List of Pin and Pin Functions (145-Pin TFLGA) (7/7)

Pin Number	Power Supply Clock System Control	I/O Port	Bus EXDMAC SDRAMC	Timer		Communication		Memory I/F Camera I/F	GLCDC	Interrupt	A/D D/A
				(MTU, TPU, TMR, PPG, RTC, CMTW, POE, CAC)	(GPTW, POEG)	(SCI, RSPI, RIIC, CAN, USB, SSIE)	(ETHERC, PMGI)				
M12		PC1	A17	MTIOC3A/ TCLKD/PO18		SCK5/ SSLA2-A	ET0_ERXD 2			IRQ12	
M13	VCC										
N1		P21		MTIOC1B/ MTIOC4A/ TIOCA3/ TMCIO/PO1	GTIOC2A	RXD0/ SMISO0/ SSCL0/ SCL1/ USB0_EXIC EN/ SSILRCK0		SDHI_CLK-C/ PIXD5		IRQ9	
N2		P20		MTIOC1A/ TIOCB3/ TMRI0/PO0		TXD0/ SMOSI0/ SSDA0/ SDA1/ USB0_ID/ SSIRXD0		SDHI_CMD-C/ PIXD4		IRQ8	
N3		P87		MTIOC4C/ TIOCA2	GTIOC1B	SMOSI10/ SSDA10/ TXD10	EPLSOUT1	SDHI_D2-C/ PIXD2			
N4		P14		MTIOC3A/ MTCLKA/ TIOCB5/ TCLKA/TMRI2/ PO15	GTETRG D	CTS1#/ RTS1#/ SS1#/CTX1/ USB0_OVRC URA				IRQ4	
N5						USB0_DM					
N6						USB0_DP					
N7	TRDATA3	P55	D0[A0/D0]/ WAIT#/ EDREQ0	MTIOC4D/ TMO3		TXD7/ SMOSI7/ SSDA7/ CRX1	ET0_EXOU T			IRQ10	
N8	VSS										
N9	UB	PC7	A23/CS0#	MTIOC3A/ MTCLKB/ TMO2/PO31/ TOC0/ CACREF	GTIOC3A	TXD8/ SMOSI8/ SSDA8/ SMOSI10/ SSDA10/ TXD10/ MISOA-A	ET0_COL	MMC_D7-A		IRQ14	
N10	TRSYNC	P82	EDREQ1	MTIOC4A/ PO28	GTIOC2A	SMOSI10/ SSDA10/ TXD10	ET0_ETXD 1/ RMII0_TXD 1	MMC_D4-A			
N11		PC3	A19	MTIOC4D/ TCLKB/PO24	GTIOC1B	TXD5/ SMOSI5/ SSDA5	ET0_TX_E R	QMO-A/QIO0- A/SDHI_D0-A/ MMC_D0-A			
N12	TRSYNC1	P75	CS5#	PO20		SCK11/ RTS11#	ET0_ERXD 0/ RMII0_RX D0	SDHI_D2-A/ MMC_RES#-A			
N13	TRDATA5	P74	A20/CS4#	PO19		SS11#/ CTS11#	ET0_ERXD 1/ RMII0_RX D1				

Note 1. P53 is multiplexed with the BCLK pin function, so cannot be used as an I/O port pin when the external bus is enabled.

1.6.5 144-Pin LQFP

Table 1.9 List of Pin and Pin Functions (144-Pin LQFP) (1/7)

Pin Number	Power Supply Clock System Control	I/O Port	Bus EXDMAC SDRAMC	Timer		Communication		Memory I/F Camera I/F	GLCDC	Interrupt	A/D D/A
				(MTU, TPU, TMR, PPG, RTC, CMTW, POE, CAC)	(GPTW, POEG)	(SCI, RSPI, RIIC, CAN, USB, SSIE)	(ETHERC, PMGI)				
1	AVSS0										
2		P05				SSILRCK1				IRQ13	DA1
3	AVCC1										
4		P03				SSIDATA1				IRQ11	DA0
5	AVSS1										
6		P02		TMC11		SCK6/ SSIBCK1				IRQ10	AN120
7		P01		TMC10		RXD6/ SMISO6/ SSCL6/ SSIBCK0				IRQ9	AN119
8		P00		TMR10		TXD6/ SMOSI6/ SSDA6/ AUDIO_CLK				IRQ8	AN118
9		PF5	WAIT#			SSILRCK0				IRQ4	
10	EMLE										
11		PJ5		POE8#		CTS2#/ RTS2#/ SS2#/ SSIRXD0	EPLSOUT0				
12	VSS										
13		PJ3	EDACK1	MTIOC3C		CTS6#/ RTS6#/ SS6#/ CTS0#/ RTS0#/ SS0#/ SSITXD0	ET0_EXOU T				
14	VCL										
15	VBATT										
16	MD/FINED										
17	XCIN										
18	XCOUT										
19	RES#										
20	XTAL	P37									
21	VSS										
22	EXTAL	P36									
23	VCC										
24	UPSEL	P35								NMI	
25	TRST#	P34		MTIOC0A/ TMC13/PO12/ POE10#		SCK6/SCK0	ET0_LINK STA			IRQ4	
26		P33	EDREQ1	MTIOC0D/ TIOC0D/ TMR13/PO11/ POE4#/ POE11#		RXD6/ SMISO6/ SSCL6/ RXD0/ SMISO0/ SSCL0/ CRX0		PCKO		IRQ3-DS	

Table 1.9 List of Pin and Pin Functions (144-Pin LQFP) (2/7)

Pin Number	Power Supply Clock System Control	I/O Port	Bus EXDMAC SDRAMC	Timer		Communication		Memory I/F Camera I/F	GLCDC	Interrupt	A/D D/A
				(MTU, TPU, TMR, PPG, RTC, CMTW, POE, CAC)	(GPTW, POEG)	(SCI, RSPI, RIIC, CAN, USB, SSIE)	(ETHERC, PMGI)				
27		P32		MTIOC0C/ TIOCC0/ TMO3/PO10/ RTCIC2/ RTCOU0/ POE0#/ POE10#		TXD6/ SMOSI6/ SSDA6/ TXD0/ SMOSI0/ SSDA0/ CTX0/ USB0_VBUS EN		VSYNC		IRQ2-DS	
28	TMS	P31		MTIOC4D/ TMCI2/PO9/ RTCIC1		CTS1#/ RTS1#/ SS1#/ SSLB0-A	ET1_MDC/ PMGI1_MD C			IRQ1-DS	
29	TDI	P30		MTIOC4B/ TMRI3/PO8/ RTCIC0/ POE8#		RXD1/ SMISO1/ SSCL1/ MISOB-A	ET1_MDIO / PMGI1_MD IO			IRQ0-DS	
30	TCK	P27	CS7#	MTIOC2B/ TMCI3/PO7		SCK1/ RSPCKB-A	ET1_WOL				
31	TDO	P26	CS6#	MTIOC2A/ TMO1/PO6		TXD1/ SMOSI1/ SSDA1/ CTS3#/ RTS3#/ SS3#/ MOSIB-A	ET1_EXOU T				
32	CLKOUT	P25	CS5#/ EDACK1	MTIOC4C/ MTCLKB/ TIOCA4/PO5		RXD3/ SMISO3/ SSCL3/ SSIDATA1		SDHI_CD/ HSYNC			ADTRG0#
33		P24	CS4#/ EDREQ1	MTIOC4A/ MTCLKA/ TIOCB4/ TMRI1/PO4		SCK3/ USB0_VBUS EN/SSIBCK1		SDHI_WP/ PIXCLK			
34		P23	EDACK0	MTIOC3D/ MTCLKD/ TIOCD3/PO3	GTIOC0A	TXD3/ SMOSI3/ SSDA3/ CTS0#/ RTS0#/ SS0#/CTX1/ SSIBCK0		SDHI_D1-C/ PIXD7			
35		P22	EDREQ0	MTIOC3B/ MTCLKC/ TIOCC3/ TMO0/PO2	GTIOC1A	SCK0/ USB0_OVRC URB/ AUDIO_CLK		SDHI_D0-C/ PIXD6			
36		P21		MTIOC1B/ MTIOC4A/ TIOCA3/ TMCI0/PO1	GTIOC2A	RXD0/ SMISO0/ SSCL0/ SCL1/ USB0_EXIC EN/ SSILRCK0		SDHI_CLK-C/ PIXD5		IRQ9	
37		P20		MTIOC1A/ TIOCB3/ TMRI0/PO0		TXD0/ SMOSI0/ SSDA0/ SDA1/ USB0_ID/ SSIRXD0		SDHI_CMD-C/ PIXD4		IRQ8	
38		P17		MTIOC3A/ MTIOC3B/ MTIOC4B/ TIOCB0/ TCLKD/TMO1/ PO15/POE8#	GTIOC0B	SCK1/TXD3/ SMOSI3/ SSDA3/ SDA2-DS/ SSITXD0	EPLSOUT0	SDHI_D3-C/ PIXD3		IRQ7	ADTRG1#
39		P87		MTIOC4C/ TIOCA2	GTIOC1B	SMOSI10/ SSDA10/ TXD10	EPLSOUT1	SDHI_D2-C/ PIXD2			

Table 1.9 List of Pin and Pin Functions (144-Pin LQFP) (3/7)

Pin Number	Power Supply Clock System Control	I/O Port	Bus EXDMAC SDRAMC	Timer		Communication		Memory I/F Camera I/F	GLCDC	Interrupt	A/D D/A	
				(MTU, TPU, TMR, PPG, RTC, CMTW, POE, CAC)	(GPTW, POEG)	(SCI, RSPI, RIIC, CAN, USB, SSIE)	(ETHERC, PMGI)					
40		P16		MTIOC3C/ MTIOC3D/ TIOCB1/ TCLKC/TMO2/ PO14/ RTCOUT		TXD1/ SMOSI1/ SSDA1/ RXD3/ SMISO3/ SSCL3/ SCL2-DS/ USB0_VBUS EN/ USB0_VBUS / USB0_OVRC URB				IRQ6	ADTRG0#	
41		P86		MTIOC4D/ TIOCA0	GTIOC2B	SMISO10/ SSCL10/ RXD10		PIXD1				
42		P15		MTIOC0B/ MTCLKB/ TIOCB2/ TCLKB/TMC12/ PO13	GTETRGA	RXD1/ SMISO1/ SSCL1/ SCK3/CRX1- DS/ SSILRCK1		PIXD0		IRQ5		
43		P14		MTIOC3A/ MTCLKA/ TIOCB5/ TCLKA/TMRI2/ PO15	GTETRGA D	CTS1#/ RTS1#/ SS1#/CTX1/ USB0_OVRC URA				IRQ4		
44		P13		MTIOC0B/ TIOCA5/ TMO3/PO13	GTADSM1	TXD2/ SMOSI2/ SSDA2/ SDA0[FM+]				IRQ3	ADTRG1#	
45		P12		TMC1	GTADSM0	RXD2/ SMISO2/ SSCL2/ SCL0[FM+]				IRQ2		
46	VCC_USB											
47						USB0_DM						
48						USB0_DP						
49	VSS_USB											
50	CLKOUT2 5M	P56	EDACK1	MTIOC3C/ TIOCA1		SCK7						
51	TRDATA3	P55	D0[A0/D0]/ WAIT#/ EDREQ0	MTIOC4D/ TMO3		TXD7/ SMOSI7/ SSDA7/ CRX1	ET0_EXOU T			IRQ10		
52	TRDATA2	P54	ALE/D1[A1/ D1]/ EDACK0	MTIOC4B/ TMC1		CTS2#/ RTS2#/ SS2#/CTX1	ET0_LINK STA					
53		P53*1	BCLK									
54		P52	RD#			RXD2/ SMISO2/ SSCL2/ SSLB3-A						
55		P51	WR1#/ BC1#/ WAIT#			SCK2/ SSLB2-A						
56		P50	WR0#/WR#			TXD2/ SMOSI2/ SSDA2/ SSLB1-A						
57	VSS											
58	TRCLK	P83	EDACK1	MTIOC4C	GTIOC0A	SCK10/ SS10#/ CTS10#	ET0_CRCS/ RMII0_CR S_DV					
59	VCC											

Table 1.9 List of Pin and Pin Functions (144-Pin LQFP) (4/7)

Pin Number	Power Supply Clock System Control	I/O Port	Bus EXDMAC SDRAMC	Timer		Communication		Memory I/F Camera I/F	GLCDC	Interrupt	A/D D/A
				(MTU, TPU, TMR, PPG, RTC, CMTW, POE, CAC)	(GPTW, POEG)	(SCI, RSPI, RIIC, CAN, USB, SSIE)	(ETHERC, PMGI)				
60	UB	PC7	A23/CS0#	MTIOC3A/ MTCLKB/ TMO2/PO31/ TOC0/ CACREF	GTIOC3A	TXD8/ SMOSI8/ SSDA8/ SMOSI10/ SSDA10/ TXD10/ MISOA-A	ET0_COL	MMC_D7-A		IRQ14	
61		PC6	D2[A2/D2]/ A22/CS1#	MTIOC3C/ MTCLKA/ TMC12/PO30/ TIC0	GTIOC3B	RXD8/ SMISO8/ SSCL8/ SMISO10/ SSCL10/ RXD10/ MOSIA-A	ET0_ETXD 3	MMC_D6-A		IRQ13	
62		PC5	D3[A3/D3]/ A21/CS2#/ WAIT#	MTIOC3B/ MTCLKD/ TMRI2/PO29	GTIOC1A	SCK8/ RTS8#/ SCK10/ RSPCKA-A	ET0_ETXD 2	MMC_D5-A			
63	TRSYNC	P82	EDREQ1	MTIOC4A/ PO28	GTIOC2A	SMOSI10/ SSDA10/ TXD10	ET0_ETXD 1/ RMII0_TXD 1	MMC_D4-A			
64	TRDATA1	P81	EDACK0	MTIOC3D/ PO27	GTIOC0B	SMISO10/ SSCL10/ RXD10	ET0_ETXD 0/ RMII0_TXD 0	QIO3-A/ SDHI_CD/ MMC_D3-A			
65	TRDATA0	P80	EDREQ0	MTIOC3B/ PO26		SCK10/ RTS10#	ET0_TX_E N/ RMII0_TXD _EN	QIO2-A/ SDHI_WP/ MMC_D2-A			
66		PC4	A20/CS3#	MTIOC3D/ MTCLKC/ TMC11/PO25/ POE0#	GTETRGC	SCK5/ CTS8#/ SS8#/SS10#/ CTS10#/ RTS10#/ SSLA0-A	ET0_TX_C LK	QMI-A/ QIO1-A/ SDHI_D1-A/ MMC_D1-A			
67		PC3	A19	MTIOC4D/ TCLKB/PO24	GTIOC1B	TXD5/ SMOSI5/ SSDA5	ET0_TX_E R	QMO-A/QIO0- A/SDHI_D0-A/ MMC_D0-A			
68	TRDATA7	P77	CS7#	PO23		SMOSI11/ SSDA11/ TXD11	ET0_RX_E R/ RMII0_RX_ ER	QSPCLK-A/ SDHI_CLK-A/ MMC_CLK-A			
69	TRDATA6	P76	CS6#	PO22		SMISO11/ SSCL11/ RXD11	ET0_RX_C LK/ REF50CK0	QSSL-A/ SDHI_CMD-A/ MMC_CMD-A			
70		PC2	A18	MTIOC4B/ TCLKA/PO21	GTIOC2B	RXD5/ SMISO5/ SSCL5/ SSLA3-A	ET0_RX_D V	SDHI_D3-A/ MMC_CD-A			
71	TRSYNC1	P75	CS5#	PO20		SCK11/ RTS11#	ET0_ERXD 0/ RMII0_RX D0	SDHI_D2-A/ MMC_RES#-A			
72	TRDATA5	P74	A20/CS4#	PO19		SS11#/ CTS11#	ET0_ERXD 1/ RMII0_RX D1				
73		PC1	A17	MTIOC3A/ TCLKD/PO18		SCK5/ SSLA2-A	ET0_ERXD 2			IRQ12	
74	VCC										
75		PC0	A16	MTIOC3C/ TCLKC/PO17		CTS5#/ RTS5#/ SS5#/ SSLA1-A	ET0_ERXD 3			IRQ14	
76	VSS										
77	TRDATA4	P73	CS3#	PO16			ET0_WOL				

Table 1.9 List of Pin and Pin Functions (144-Pin LQFP) (5/7)

Pin Number	Power Supply Clock System Control	I/O Port	Bus EXDMAC SDRAMC	Timer		Communication		Memory I/F Camera I/F	GLCDC	Interrupt	A/D D/A
				(MTU, TPU, TMR, PPG, RTC, CMTW, POE, CAC)	(GPTW, POEG)	(SCI, RSPI, RIIC, CAN, USB, SSIE)	(ETHERC, PMGI)				
78		PB7	A15	MTIOC3B/ TIOCB5/PO31		TXD9/ SMOSI9/ SSDA9/ SMOSI11/ SSDA11/ TXD11	ET0_CRS/ RMII0_CR S_DV				
79		PB6	A14	MTIOC3D/ TIOCA5/PO30		RXD9/ SMISO9/ SSCL9/ SMISO11/ SSCL11/ RXD11	ET0_ETXD 1/ RMII0_TXD 1				
80		PB5	A13	MTIOC2A/ MTIOC1B/ TIOCB4/ TMRI1/PO29/ POE4#		SCK9/ RTS9#/ SCK11	ET0_ETXD 0/ RMII0_TXD 0		LCD_CLK- B		
81		PB4	A12	TIOCA4/PO28		CTS9#/ SS9#/SS11#/ CTS11#/ RTS11#	ET0_TX_E N/ RMII0_TXD _EN		LCD_TCO N0-B		
82		PB3	A11	MTIOC0A/ MTIOC4A/ TIOCD3/ TCLKD/TMO0/ PO27/POE11#		SCK4/SCK6	ET0_RX_E R/ RMII0_RX_ ER		LCD_TCO N1-B		
83		PB2	A10	TIOCC3/ TCLKC/PO26		CTS4#/ RTS4#/ SS4#/ CTS6#/ RTS6#/SS6#	ET0_RX_C LK/ REF50CK0		LCD_TCO N2-B		
84		PB1	A9	MTIOC0C/ MTIOC4C/ TIOCB3/ TMCI0/PO25		TXD4/ SMOSI4/ SSDA4/ TXD6/ SMOSI6/ SSDA6	ET0_ERXD 0/ RMII0_RX D0		LCD_TCO N3-B	IRQ4-DS	
85		P72	A19/CS2#				ET0_MDC/ PMGIO_MD C				
86		P71	A18/CS1#				ET0_MDIO / PMGIO_MD IO				
87		PB0	A8	MTIC5W/ TIOCA3/PO24		RXD4/ SMISO4/ SSCL4/ RXD6/ SMISO6/ SSCL6	ET0_ERXD 1/ RMII0_RX D1		LCD_DAT A0-B	IRQ12	
88		PA7	A7	TIOCB2/PO23		MISOA-B	ET0_WOL		LCD_DAT A1-B		
89		PA6	A6	MTIC5V/ MTCLKB/ TIOCA2/ TMCI3/PO22/ POE10#	GTETRGB	CTS5#/ RTS5#/ SS5#/ MOSIA-B	ET0_EXOU T		LCD_DAT A2-B		
90		PA5	A5	MTIOC6B/ TIOCB1/PO21	GTIOC0A	RSPCKA-B	ET0_LINK STA		LCD_DAT A3-B		
91	VCC										
92		PA4	A4	MTIC5U/ MTCLKA/ TIOCA1/ TMRI0/PO20		TXD5/ SMOSI5/ SSDA5/ SSLA0-B	ET0_MDC/ PMGIO_MD C		LCD_DAT A4-B	IRQ5-DS	
93	VSS										

Table 1.9 List of Pin and Pin Functions (144-Pin LQFP) (6/7)

Pin Number	Power Supply Clock System Control	I/O Port	Bus EXDMAC SDRAMC	Timer		Communication		Memory I/F Camera I/F	GLCDC	Interrupt	A/D D/A
				(MTU, TPU, TMR, PPG, RTC, CMTW, POE, CAC)	(GPTW, POEG)	(SCI, RSPI, RIIC, CAN, USB, SSIE)	(ETHERC, PMGI)				
94		PA3	A3	MTIOC0D/ MTCLKD/ TIOC0D/ TCLKB/PO19		RXD5/ SMISO5/ SSCL5	ET0_MDIO / PMGIO_MD IO		LCD_DAT A5-B	IRQ6-DS	
95		PA2	A2	MTIOC7A/ PO18	GTIOC1A	RXD5/ SMISO5/ SSCL5/ SSLA3-B			LCD_DAT A6-B		
96		PA1	A1	MTIOC0B/ MTCLKC/ MTIOC7B/ TIOCB0/PO17	GTIOC2A	SCK5/ SSLA2-B	ET0_WOL		LCD_DAT A7-B	IRQ11	
97		PA0	BC0#/A0	MTIOC4A/ MTIOC6D/ TIOCA0/PO16/ CACREF	GTIOC0B	SSLA1-B	ET0_TX_E N/ RMII0_TXD _EN		LCD_DAT A8-B		
98		P67	DQM1/ CS7#	MTIOC7C	GTIOC1B	CRX2	EPLSOUT1			IRQ15	
99		P66	DQM0/ CS6#	MTIOC7D	GTIOC2B	CTX2					
100		P65	CKE/CS5#								
101		PE7	D15[A15/ D15]/D7[A7/ D7]	MTIOC6A/ TOC1	GTIOC3A	MISOB-B		SDHL_WP/ MMC_RES#-B	LCD_DAT A9-B	IRQ7	AN105
102		PE6	D14[A14/ D14]/D6[A6/ D6]	MTIOC6C/ TIC1	GTIOC3B	MOSIB-B		SDHL_CD/ MMC_CD-B	LCD_DAT A10-B	IRQ6	AN104
103	VCC										
104		P70	SDCLK								
105	VSS										
106		PE5	D13[A13/ D13]/D5[A5/ D5]	MTIOC4C/ MTIOC2B	GTIOC0A	RSPCKB-B	ET0_RX_C LK/ REF50CK0		LCD_DAT A11-B	IRQ5	AN103
107		PE4	D12[A12/ D12]/D4[A4/ D4]	MTIOC4D/ MTIOC1A/ PO28	GTIOC1A	SSLB0-B	ET0_ERXD 2		LCD_DAT A12-B		AN102
108		PE3	D11[A11/ D11]/D3[A3/ D3]	MTIOC4B/ PO26/TOC3/ POE8#	GTIOC2A	CTS12#/ RTS12#/ SS12#	ET0_ERXD 3	MMC_D7-B	LCD_DAT A13-B		AN101
109		PE2	D10[A10/ D10]/D2[A2/ D2]	MTIOC4A/ PO23/TIC3	GTIOC0B	RXD12/ SMISO12/ SSCL12/ RXDX12/ SSLB3-B		MMC_D6-B	LCD_DAT A14-B	IRQ7-DS	AN100
110		PE1	D9[A9/D9]/ D1[A1/D1]	MTIOC4C/ MTIOC3B/ PO18	GTIOC1B	TXD12/ SMOS12/ SSDA12/ TXDX12/ SIOX12/ SSLB2-B		MMC_D5-B	LCD_DAT A15-B		ANEX1
111		PE0	D8[A8/D8]/ D0[A0/D0]	MTIOC3D	GTIOC2B	SCK12/ SSLB1-B		MMC_D4-B	LCD_DAT A16-B		ANEX0
112		P64	WE#/D3[A3/ D3]/CS4#				RMII1_TXD 0				
113		P63	CAS#/ D2[A2/D2]/ CS3#				RMII1_TXD 1				
114		P62	RAS#/ D1[A1/D1]/ CS2#				RMII1_RX D0				
115		P61	SDCS#/ D0[A0/D0]/ CS1#				RMII1_RX D1				
116	VSS										

Table 1.9 List of Pin and Pin Functions (144-Pin LQFP) (7/7)

Pin Number	Power Supply Clock System Control	I/O Port	Bus EXDMAC SDRAMC	Timer		Communication			Memory I/F Camera I/F	GLCDC	Interrupt	A/D D/A
				(MTU, TPU, TMR, PPG, RTC, CMTW, POE, CAC)	(GPTW, POEG)	(SCI, RSPI, RIIC, CAN, USB, SSIE)	(ETHERC, PMGI)	(QSPI, SDHI, MMCIF, PDC)				
117		P60	CS0#					RMII1_TXD_EN				
118	VCC											
119		PD7	D7[A7/D7]	MTIC5U/POE0#		SSLC3-A	RMII1_RX_ER	QMI-B/ QIO1-B/ SDHI_D1-B/ MMC_D1-B	LCD_DAT A17-B	IRQ7		AN107
120		PD6	D6[A6/D6]	MTIC5V/ MTIOC8A/ POE4#		SSLC2-A	REF50CK1	QMO-B/QIO0-B/ SDHI_D0-B/ MMC_D0-B	LCD_DAT A18-B	IRQ6		AN106
121		PD5	D5[A5/D5]	MTIC5W/ MTIOC8C/ MTCLKA/ POE10#		SSLC1-A	ET1_MDC/ PMGI1_MD C	QSPCLK-B/ SDHI_CLK-B/ MMC_CLK-B	LCD_DAT A19-B	IRQ5		AN113
122		PD4	D4[A4/D4]	MTIOC8B/ POE11#		SSLC0-A	ET1_MDIO/ PMGI1_MD IO	QSSL-B/ SDHI_CMD-B/ MMC_CMD-B	LCD_DAT A20-B	IRQ4		AN112
123		PD3	D3[A3/D3]	MTIOC8D/ TOC2/POE8#	GTIOC0A	RSPCKC-A	ET1_WOL	QIO3-B/ SDHI_D3-B/ MMC_D3-B	LCD_DAT A21-B	IRQ3		AN111
124		PD2	D2[A2/D2]	MTIOC4D/ TIC2	GTIOC0B	MISOC-A/ CRX0	ET1_EXOU T	QIO2-B/ SDHI_D2-B/ MMC_D2-B	LCD_DAT A22-B	IRQ2		AN110
125		PD1	D1[A1/D1]	MTIOC4B/ POE0#	GTIOC1A	MOSIC-A/ CTX0			LCD_DAT A23-B	IRQ1		AN109
126		PD0	D0[A0/D0]	POE4#	GTIOC1B				LCD_EXT CLK-B	IRQ0		AN108
127		P93	A19	POE0#		CTS7#/ RTS7#/SS7#	ET1_LINK STA					AN117
128		P92	A18	POE4#		RXD7/ SMISO7/ SSCL7	RMII1_CR S_DV					AN116
129		P91	A17			SCK7						AN115
130	VSS											
131		P90	A16			TXD7/ SMOSI7/ SSDA7						AN114
132	VCC											
133		P47									IRQ15-DS	AN007
134		P46									IRQ14-DS	AN006
135		P45									IRQ13-DS	AN005
136		P44									IRQ12-DS	AN004
137		P43									IRQ11-DS	AN003
138		P42									IRQ10-DS	AN002
139		P41									IRQ9-DS	AN001
140	VREFL0											
141		P40									IRQ8-DS	AN000
142	VREFH0											
143	AVCC0											
144		P07									IRQ15	ADTRG0#

Note 1. P53 is multiplexed with the BCLK pin function, so cannot be used as an I/O port pin when the external bus is enabled.

1.6.6 100-Pin LFQFP

Table 1.10 List of Pin and Pin Functions (100-Pin LFQFP) (1/6)

Pin Number	Power Supply Clock System Control	I/O Port	Bus EXDMAC	Timer		Communication		Memory I/F Camera I/F	GLCDC	Interrupt	A/D D/A
				(MTU, TPU, TMR, PPG, RTC, CMTW, POE, CAC)	(GPTW, POEG)	(SCI, RSPI, RIIC, CAN, USB, SSIE)	(ETHERC, PMGI)				
1	AVCC1										
2	EMLE										
3	AVSS1										
4		PJ3	EDACK1	MTIOC3C		CTS6#/ RTS6#/ SS6#/ CTS0#/ RTS0#/ SS0#/ SSITXD0	ET0_EXOU T				
5	VCL										
6	VBATT										
7	MD/FINED										
8	XCIN										
9	XCOUT										
10	RES#										
11	XTAL	P37									
12	VSS										
13	EXTAL	P36									
14	VCC										
15	UPSEL	P35								NMI	
16	TRST#	P34		MTIOC0A/ TMCI3/PO12/ POE10#		SCK6/SCK0	ET0_LINK STA			IRQ4	
17		P33	EDREQ1	MTIOC0D/ TIOC0D/ TMRI3/PO11/ POE4#/ POE11#		RXD6/ SMISO6/ SSCL6/ RXD0/ SMISO0/ SSCL0/ CRX0				IRQ3-DS	
18		P32		MTIOC0C/ TIOCC0/ TMO3/PO10/ RTCIC2/ RTCOUT/ POE0#/ POE10#		TXD6/ SMOSI6/ SSDA6/ TXD0/ SMOSI0/ SSDA0/ CTX0/ USB0_VBUS EN				IRQ2-DS	
19	TMS	P31		MTIOC4D/ TMC12/PO9/ RTCIC1		CTS1#/ RTS1#/ SS1#/ SSLB0-A				IRQ1-DS	
20	TDI	P30		MTIOC4B/ TMRI3/PO8/ RTCIC0/ POE8#		RXD1/ SMISO1/ SSCL1/ MISOB-A				IRQ0-DS	
21	TCK	P27	CS7#	MTIOC2B/ TMCI3/PO7		SCK1/ RSPCKB-A					
22	TDO	P26	CS6#	MTIOC2A/ TMO1/PO6		TXD1/ SMOSI1/ SSDA1/ CTS3#/ RTS3#/ SS3#/ MOSIB-A					

Table 1.10 List of Pin and Pin Functions (100-Pin LQFP) (2/6)

Pin Number	Power Supply Clock System Control	I/O Port	Bus EXDMAC	Timer		Communication		Memory I/F Camera I/F	GLCDC	Interrupt	A/D D/A
				(MTU, TPU, TMR, PPG, RTC, CMTW, POE, CAC)	(GPTW, POEG)	(SCI, RSPI, RIIC, CAN, USB, SSIE)	(ETHERC, PMGI)				
23	CLKOUT	P25	CS5#/ EDACK1	MTIOC4C/ MTCLKB/ TIOCA4/PO5		RXD3/ SMISO3/ SSCL3/ SSIDATA1					ADTRG0#
24		P24	CS4#/ EDREQ1	MTIOC4A/ MTCLKA/ TIOCB4/ TMRI1/PO4		SCK3/ USB0_VBUS EN/SSIBCK1					
25		P23	EDACK0	MTIOC3D/ MTCLKD/ TIOCD3/PO3	GTIOC0A	TXD3/ SMOSI3/ SSDA3/ CTS0#/ RTS0#/ SS0#/CTX1/ SSIBCK0					
26		P22	EDREQ0	MTIOC3B/ MTCLKC/ TIOCC3/ TMO0/PO2	GTIOC1A	SCK0/ USB0_OVRC URB/ AUDIO_CLK					
27		P21		MTIOC1B/ MTIOC4A/ TIOCA3/ TMCI0/PO1	GTIOC2A	RXD0/ SMISO0/ SSCL0/ USB0_EXIC EN/ SSILRCK0/ SCL1				IRQ9	
28		P20		MTIOC1A/ TIOCB3/ TMRI0/PO0		TXD0/ SMOSI0/ SSDA0/ USB0_ID/ SSIRXD0/ SDA1				IRQ8	
29		P17		MTIOC3A/ MTIOC3B/ MTIOC4B/ TIOCB0/ TCLKD/TMO1/ PO15/POE8#	GTIOC0B	SCK1/TXD3/ SMOSI3/ SSDA3/ SDA2-DS/ SSITXD0	EPLSOUT0			IRQ7	ADTRG1#
30		P16		MTIOC3C/ MTIOC3D/ TIOCB1/ TCLKC/TMO2/ PO14/ RTCOUT		TXD1/ SMOSI1/ SSDA1/ RXD3/ SMISO3/ SSCL3/ SCL2-DS/ USB0_VBUS EN/ USB0_VBUS / USB0_OVRC URB			IRQ6	ADTRG0#	
31		P15		MTIOC0B/ MTCLKB/ TIOCB2/ TCLKB/TMCI2/ PO13	GTETRGA	RXD1/ SMISO1/ SSCL1/ SCK3/ CRX1-DS/ SSILRCK1				IRQ5	
32		P14		MTIOC3A/ MTCLKA/ TIOCB5/ TCLKA/TMRI2/ PO15	GTETRGD	CTS1#/ RTS1#/ SS1#/CTX1/ USB0_OVRC URA				IRQ4	
33		P13		MTIOC0B/ TIOCA5/ TMO3/PO13	GTADSM1	TXD2/ SMOSI2/ SSDA2/ SDA0[FM+]				IRQ3	ADTRG1#
34		P12		TMCI1	GTADSM0	RXD2/ SMISO2/ SSCL2/ SCL0[FM+]				IRQ2	

Table 1.10 List of Pin and Pin Functions (100-Pin LQFP) (3/6)

Pin Number	Power Supply Clock System Control	I/O Port	Bus EXDMAC	Timer		Communication		Memory I/F Camera I/F	GLCDC	Interrupt	A/D D/A
				(MTU, TPU, TMR, PPG, RTC, CMTW, POE, CAC)	(GPTW, POEG)	(SCI, RSPI, RIIC, CAN, USB, SSIE)	(ETHERC, PMGI)				
35	VCC_USB										
36						USB0_DM					
37						USB0_DP					
38	VSS_USB										
39		P55	D0[A0/D0]/ WAIT#/ EDREQ0	MTIOC4D/ TMO3		CRX1	ET0_EXOU T			IRQ10	
40		P54	ALE/ D1[A1/D1]/ EDACK0	MTIOC4B/ TMCI1		CTS2#/ RTS2#/ SS2#/CTX1	ET0_LINK STA				
41		P53*1	BCLK								
42		P52	RD#			RXD2/ SMISO2/ SSCL2/ SSLB3-A					
43		P51	WR1#/ BC1#/ WAIT#			SCK2/ SSLB2-A					
44		P50	WR0#/WR#			TXD2/ SMOSI2/ SSDA2/ SSLB1-A					
45	UB	PC7	A23/CS0#	MTIOC3A/ MTCLKB/ TMO2/PO31/ TOC0/ CACREF	GTIOC3A	TXD8/ SMOSI8/ SSDA8/ SMOSI10/ SSDA10/ TXD10/ MISOA-A	ET0_COL			IRQ14	
46		PC6	D2[A2/D2]/ A22/CS1#	MTIOC3C/ MTCLKA/ TMCI2/PO30/ TIC0	GTIOC3B	RXD8/ SMISO8/ SSCL8/ SMISO10/ SSCL10/ RXD10/ MOSIA-A	ET0_ETXD 3			IRQ13	
47		PC5	D3[A3/D3]/ A21/CS2#/ WAIT#	MTIOC3B/ MTCLKD/ TMRI2/PO29	GTIOC1A	SCK8/ RTS8#/ SCK10/ RSPCKA-A	ET0_ETXD 2				
48		PC4	A20/CS3#	MTIOC3D/ MTCLKC/ TMCI1/PO25/ POE0#	GTETRG C	SCK5/ CTS8#/ SS8#/SS10#/ CTS10#/ RTS10#/ SSLA0-A	ET0_TX_C LK				
49		PC3	A19	MTIOC4D/ TCLKB/PO24	GTIOC1B	TXD5/ SMOSI5/ SSDA5	ET0_TX_E R				
50		PC2	A18	MTIOC4B/ TCLKA/PO21	GTIOC2B	RXD5/ SMISO5/ SSCL5/ SSLA3-A	ET0_RX_D V				
51		PC1	A17	MTIOC3A/ TCLKD/PO18		SCK5/ SSLA2-A	ET0_ERXD 2			IRQ12	
52		PC0	A16	MTIOC3C/ TCLKC/PO17		CTS5#/ RTS5#/ SS5#/ SSLA1-A	ET0_ERXD 3			IRQ14	
53		PB7	A15	MTIOC3B/ TIOCB5/PO31		TXD9/ SMOSI9/ SSDA9/ SMOSI11/ SSDA11/ TXD11	ET0_CRS/ RMII0_CR S_DV				

Table 1.10 List of Pin and Pin Functions (100-Pin LQFP) (4/6)

Pin Number	Power Supply Clock System Control	I/O Port	Bus EXDMAC	Timer		Communication		Memory I/F Camera I/F	GLCDC	Interrupt	A/D D/A
				(MTU, TPU, TMR, PPG, RTC, CMTW, POE, CAC)	(GPTW, POEG)	(SCI, RSPI, RIC, CAN, USB, SSIE)	(ETHERC, PMGI)				
54		PB6	A14	MTIOC3D/ TIOCA5/PO30		RXD9/ SMISO9/ SSCL9/ SMISO11/ SSCL11/ RXD11	ET0_ETXD 1/ RMII0_TXD 1				
55		PB5	A13	MTIOC2A/ MTIOC1B/ TIOCB4/ TMRI1/PO29/ POE4#		SCK9/ RTS9#/ SCK11	ET0_ETXD 0/ RMII0_TXD 0		LCD_CLK- B		
56		PB4	A12	TIOCA4/PO28		CTS9#/ SS9#/SS11#/ CTS11#/ RTS11#	ET0_TX_E N/ RMII0_TXD _EN		LCD_TCO N0-B		
57		PB3	A11	MTIOC0A/ MTIOC4A/ TIOCD3/ TCLKD/TMO0/ PO27/POE11#		SCK6	ET0_RX_E R/ RMII0_RX_ ER		LCD_TCO N1-B		
58		PB2	A10	TIOCC3/ TCLKC/PO26		CTS6#/ RTS6#/SS6#	ET0_RX_C LK/ REF50CK0		LCD_TCO N2-B		
59		PB1	A9	MTIOC0C/ MTIOC4C/ TIOCB3/ TMCI0/PO25		TXD6/ SMOSI6/ SSDA6	ET0_ERXD 0/ RMII0_RX D0		LCD_TCO N3-B	IRQ4-DS	
60	VCC										
61		PB0	A8	MTIC5W/ TIOCA3/PO24		RXD6/ SMISO6/ SSCL6	ET0_ERXD 1/ RMII0_RX D1		LCD_DAT A0-B	IRQ12	
62	VSS										
63		PA7	A7	TIOCB2/PO23		MISOA-B	ET0_WOL		LCD_DAT A1-B		
64		PA6	A6	MTIC5V/ MTCLKB/ TIOCA2/ TMCI3/PO22/ POE10#	GTETRGB	CTS5#/ RTS5#/ SS5#/ MOSIA-B	ET0_EXOU T		LCD_DAT A2-B		
65		PA5	A5	MTIOC6B/ TIOCB1/PO21	GTIOC0A	RSPCKA-B	ET0_LINK STA		LCD_DAT A3-B		
66		PA4	A4	MTIC5U/ MTCLKA/ TIOCA1/ TMRI0/PO20		TXD5/ SMOSI5/ SSDA5/ SSLA0-B	ET0_MDC/ PMGIO_MD C		LCD_DAT A4-B	IRQ5-DS	
67		PA3	A3	MTIOC0D/ MTCLKD/ TIOCD0/ TCLKB/PO19		RXD5/ SMISO5/ SSCL5	ET0_MDIO / PMGIO_MD IO		LCD_DAT A5-B	IRQ6-DS	
68		PA2	A2	MTIOC7A/ PO18	GTIOC1A	RXD5/ SMISO5/ SSCL5/ SSLA3-B			LCD_DAT A6-B		
69		PA1	A1	MTIOC0B/ MTCLKC/ MTIOC7B/ TIOCB0/PO17	GTIOC2A	SCK5/ SSLA2-B	ET0_WOL		LCD_DAT A7-B	IRQ11	
70		PA0	BC0#/A0	MTIOC4A/ MTIOC6D/ TIOCA0/PO16/ CACREF	GTIOC0B	SSLA1-B	ET0_TX_E N/ RMII0_TXD _EN		LCD_DAT A8-B		
71		PE7	D15[A15/ D15]/D7[A7/ D7]	MTIOC6A/ TOC1	GTIOC3A	MISOB-B		SDHI_WP/ MMC_RES#-B	LCD_DAT A9-B	IRQ7	AN105

Table 1.10 List of Pin and Pin Functions (100-Pin LQFP) (5/6)

Pin Number	Power Supply Clock System Control	I/O Port	Bus EXDMAC	Timer		Communication			Memory I/F Camera I/F	GLCDC	Interrupt	A/D D/A
				(MTU, TPU, TMR, PPG, RTC, CMTW, POE, CAC)	(GPTW, POEG)	(SCI, RSPI, RIIC, CAN, USB, SSIE)	(ETHERC, PMGI)	(QSPI, SDHI, MMCIF)				
72		PE6	D14[A14/D14]/D6[A6/D6]	MTIOC6C/TIC1	GTIOC3B	MOSIB-B		SDHI_CD/MMC_CD-B	LCD_DAT A10-B	IRQ6	AN104	
73		PE5	D13[A13/D13]/D5[A5/D5]	MTIOC4C/MTIOC2B	GTIOC0A	RSPCKB-B	ET0_RX_C LK/ REF50CK0		LCD_DAT A11-B	IRQ5	AN103	
74		PE4	D12[A12/D12]/D4[A4/D4]	MTIOC4D/MTIOC1A/PO28	GTIOC1A	SSLB0-B	ET0_ERXD 2		LCD_DAT A12-B		AN102	
75		PE3	D11[A11/D11]/D3[A3/D3]	MTIOC4B/PO26/TOC3/POE8#	GTIOC2A	CTS12#/RTS12#/SS12#	ET0_ERXD 3	MMC_D7-B	LCD_DAT A13-B		AN101	
76		PE2	D10[A10/D10]/D2[A2/D2]	MTIOC4A/PO23/TIC3	GTIOC0B	RXD12/SMISO12/SSCL12/RXDX12/SSLB3-B		MMC_D6-B	LCD_DAT A14-B	IRQ7-DS	AN100	
77		PE1	D9[A9/D9]/D1[A1/D1]	MTIOC4C/MTIOC3B/PO18	GTIOC1B	TXD12/SMOSH12/SSDA12/TXDX12/SIOX12/SSLB2-B		MMC_D5-B	LCD_DAT A15-B		ANEX1	
78		PE0	D8[A8/D8]/D0[A0/D0]	MTIOC3D	GTIOC2B	SCK12/SSLB1-B		MMC_D4-B	LCD_DAT A16-B		ANEX0	
79		PD7	D7[A7/D7]	MTIC5U/POE0#		SSLC3-A		QMI-B/QIO1-B/SDHI_D1-B/MMC_D1-B	LCD_DAT A17-B	IRQ7	AN107	
80		PD6	D6[A6/D6]	MTIC5V/MTIOC8A/POE4#		SSLC2-A		QMO-B/QIO0-B/SDHI_D0-B/MMC_D0-B	LCD_DAT A18-B	IRQ6	AN106	
81		PD5	D5[A5/D5]	MTIC5W/MTIOC8C/MTCLKA/POE10#		SSLC1-A		QSPCLK-B/SDHI_CLK-B/MMC_CLK-B	LCD_DAT A19-B	IRQ5	AN113	
82		PD4	D4[A4/D4]	MTIOC8B/POE11#		SSLC0-A		QSSL-B/SDHI_CMD-B/MMC_CMD-B	LCD_DAT A20-B	IRQ4	AN112	
83		PD3	D3[A3/D3]	MTIOC8D/TOC2/POE8#	GTIOC0A	RSPCKC-A		QIO3-B/SDHI_D3-B/MMC_D3-B	LCD_DAT A21-B	IRQ3	AN111	
84		PD2	D2[A2/D2]	MTIOC4D/TIC2	GTIOC0B	MISOC-A/CRX0		QIO2-B/SDHI_D2-B/MMC_D2-B	LCD_DAT A22-B	IRQ2	AN110	
85		PD1	D1[A1/D1]	MTIOC4B/POE0#	GTIOC1A	MOSIC-A/CTX0			LCD_DAT A23-B	IRQ1	AN109	
86		PD0	D0[A0/D0]	POE4#	GTIOC1B				LCD_EXT CLK-B	IRQ0	AN108	
87		P47								IRQ15-DS	AN007	
88		P46								IRQ14-DS	AN006	
89		P45								IRQ13-DS	AN005	
90		P44								IRQ12-DS	AN004	
91		P43								IRQ11-DS	AN003	
92		P42								IRQ10-DS	AN002	
93		P41								IRQ9-DS	AN001	
94	VREFL0											
95		P40								IRQ8-DS	AN000	
96	VREFH0											
97	AVCC0											
98		P07								IRQ15	ADTRG0#	

Table 1.10 List of Pin and Pin Functions (100-Pin LQFP) (6/6)

Pin Number	Power Supply Clock System Control	I/O Port	Bus EXDMAC	Timer		Communication		Memory I/F Camera I/F	GLCDC	Interrupt	A/D D/A
				(MTU, TPU, TMR, PPG, RTC, CMTW, POE, CAC)	(GPTW, POEG)	(SCI, RSPI, RIIC, CAN, USB, SSIE)	(ETHERC, PMGI)				
99	AVSS0										
100		P05				SSILRCK1				IRQ13	DA1

Note 1. P53 is multiplexed with the BCLK pin function, so cannot be used as an I/O port pin when the external bus is enabled.

2. Electrical Characteristics

2.1 Absolute Maximum Ratings

Table 2.1 Absolute Maximum Rating

Conditions: VSS = AVSS0 = AVSS1 = VREFL0 = VSS_USB = 0 V

Item	Symbol	Value	Unit	
Power supply voltage	VCC, VCC_USB	-0.3 to +4.0	V	
V _{BATT} power supply voltage	V _{BATT}	-0.3 to +4.0	V	
Input voltage (except for ports for 5 V tolerant*1)	V _{in}	-0.3 to VCC + 0.3 (up to 4.0)	V	
Input voltage (ports for 5 V tolerant*1)	V _{in}	-0.3 to VCC + 4.0 (up to 5.8)	V	
Reference power supply voltage	VREFH0	-0.3 to AVCC0 + 0.3 (up to 4.0)	V	
Analog power supply voltage	AVCC0, AVCC1*2	-0.3 to +4.0	V	
Analog input voltage	V _{AN}	-0.3 to AVCC + 0.3 (up to 4.0)	V	
Junction temperature	D version	T _j	-40 to +105	°C
	G version	T _j	-40 to +125	°C
Storage temperature	T _{stg}	-55 to +125	°C	

Caution: Permanent damage to the LSI may result if absolute maximum ratings are exceeded.

Note 1. P07, P11 to P17, P20, P21, P30 to P33, P67, and PC0 to PC3 are 5 V tolerant.

Note 2. Connect the AVCC0, AVCC1, and VCC_USB pins to VCC, and the AVSS0, AVSS1, and VSS_USB pins to VSS.

When the A/D converter unit 0 is not to be used, connect the VREFH0 pin to VCC and the VREFL0 pin to VSS, respectively.

Do not leave these pins open. Insert capacitors of high frequency characteristics between the AVCC0 and AVSS0 pins, or AVCC1 and AVSS1 pins. Place capacitors of about 0.1 μF as close as possible to every power supply pin and use the shortest and heaviest possible traces.

2.2 Recommended Operating Conditions

Table 2.2 Recommended Operating Conditions (1)

Item	Symbol	Min.	Typ.	Max.	Unit
Power supply voltage*1	VCC	2.7	—	3.6	V
	VSS	—	0	—	
V _{BATT} power supply voltage	V _{BATT}	2.0	—	3.6	V
USB power supply voltage	VCC_USB	—	VCC	—	V
	VSS_USB	—	0	—	
Analog power supply voltage*1, *2	AVCC0	—	VCC	—	V
	AVSS0	—	0	—	
	AVCC1	—	VCC	—	
	AVSS1	—	0	—	
	VREFH0	2.7	—	AVCC0	
	VREFL0	—	0	—	
Input voltage (except for 5 V tolerant ports, except for P03, P05 and P40 to P47)*3	V _{in}	−0.3	—	VCC + 0.3	V
Input voltage (P03, P05 and P40 to P47)	V _{in}	−0.3	—	AVCC0 + 0.3	V
Input voltage (5V tolerant ports: P11 to P17, P20, P21, P30 to P33, P67, and PC0 to PC3)*4	V _{in}	−0.3	—	VCC + 3.6 (up to 5.5)	V
Input voltage (5V tolerant port: P07)	V _{in}	−0.3	—	AVCC0 + 3.6 (up to 5.5)	V
Operating temperature (D version)	T _{opr}	−40	—	85	°C
Operating temperature (G version)	T _{opr}	−40	—	105	°C

Note 1. Comply with the following potential condition: VCC = AVCC0 = AVCC1 = VCC_USB

Note 2. For details, refer to section 56.6.11, Voltage Range of Analog Power Supply Pins in the User's Manual: Hardware.

Note 3. P07, P11 to P17, P20, P21, P30 to P33, P67, and PC0 to PC3 are 5 V tolerant.

Note 4. For P30 to P32, input as follows when the V_{BATT} power supply is selected.

V_{in} Min. = −0.3, Max. = V_{BATT} + 0.3 (V_{BATT} = 2.0 to 3.6 V)

Table 2.3 Recommended Operating Conditions (2)

Item	Symbol	Value
Decoupling capacitance to stabilize the internal voltage	C _{VCL}	0.22 μF ± 30%*1

Note 1. Use a multilayer ceramic capacitor whose nominal capacitance is 0.22 μF and a capacitance tolerance is ±30% or better.

2.3 DC Characteristics

Table 2.4 DC Characteristics (1)

Conditions: $V_{CC} = AV_{CC0} = AV_{CC1} = V_{CC_USB} = V_{BATT} = 2.7$ to 3.6 V, 2.7 V $\leq V_{REFH0} \leq AV_{CC0}$,
 $V_{SS} = AV_{SS0} = AV_{SS1} = V_{REFL0} = V_{SS_USB} = 0$ V,
 $T_a = T_{opr}$

Item		Symbol	Min.	Typ.	Max.	Unit	Test Conditions	
Schmitt trigger input voltage	IRQ input pin*1, MTU input pin*1, POE input pin*1, TPU input pin*1, TMR input pin*1, CMTW input pin*1, SCI input pin*1, CAN input pin*1, CAC input pin*1, ADTRG# input pin*1, QSPI input pin*1, SSIE input pin*1, GPTW input pin*1, POEG input pin*1, RES#, NMI, TCK	V_{IH}	$0.8 \times V_{CC}$	—	—	V		
		V_{IL}	—	—	$0.2 \times V_{CC}$			
		ΔV_T	$0.06 \times V_{CC}$	—	—			
	RIIC input pin (except for SMBus)	V_{IH}	$0.7 \times V_{CC}$	—	—			
		V_{IL}	—	—	$0.3 \times V_{CC}$			
		ΔV_T	$0.05 \times V_{CC}$	—	—			
	Ports for 5 V tolerant*2	V_{IH}	$0.8 \times V_{CC}$	—	—			
		V_{IL}	—	—	$0.2 \times V_{CC}$			
	Other input pins excluding ports for 5 V tolerant*3	V_{IH}	$0.8 \times V_{CC}$	—	—			
		V_{IL}	—	—	$0.2 \times V_{CC}$			
	High level input voltage (except for Schmitt trigger input pin)	MD pin, EMLE	V_{IH}	$0.9 \times V_{CC}$	—	—		V
		EXTAL, RSPI input pin, EXDMAC input pin, WAIT#, SDHI input pin, MMC input pin, PDC input pin, PMGI input pin		$0.8 \times V_{CC}$	—	—		
ETHERC input pin		2.3		—	—			
D0 to D31		$0.7 \times V_{CC}$		—	—			
RIIC (SMBus)		2.1		—	—			
Low level input voltage (except for Schmitt trigger input pin)	MD pin, EMLE	V_{IL}	—	—	$0.1 \times V_{CC}$	V		
	EXTAL, RSPI input pin, ETHERC input pin, EXDMAC input pin, WAIT#, SDHI input pin, MMC input pin, PDC input pin, PMGI input pin		—	—	$0.2 \times V_{CC}$			
	D0 to D31		—	—	$0.3 \times V_{CC}$			
	RIIC (SMBus)		—	—	0.8			

Note 1. This does not include the pins, which are multiplexed as ports for 5 V tolerant.

Note 2. P07, P11 to P17, P20, P21, P30 to P33, P67, and PC0 to PC3 are 5 V tolerant.

Note 3. For P30 to P32, input as follows when the V_{BATT} power supply is selected.

V_{IH} Min. = $V_{BATT} \times 0.8$, V_{IL} Max. = $V_{BATT} \times 0.2$ ($V_{BATT} = 2.0$ to 3.6 V)

Table 2.5 DC Characteristics (2)

Conditions: $V_{CC} = AV_{CC0} = AV_{CC1} = V_{CC_USB} = V_{BATT} = 2.7$ to 3.6 V, 2.7 V $\leq V_{REFH0} \leq AV_{CC0}$,
 $V_{SS} = AV_{SS0} = AV_{SS1} = V_{REFL0} = V_{SS_USB} = 0$ V,
 $T_a = T_{opr}$

Item	Symbol	Min.	Typ.	Max.	Unit	Test Conditions	
Output high voltage	All output pins	V_{OH}	$V_{CC} - 0.5$	—	—	V	$I_{OH} = -1$ mA
Output low voltage	All output pins (except for RIIC pins and ETHERC output pin)	V_{OL}	—	—	0.5	V	$I_{OL} = 1.0$ mA
	RIIC output pin		—	—	0.4		$I_{OL} = 3.0$ mA
			—	—	0.6		$I_{OL} = 6.0$ mA
	RIIC output pin (only P12 and P13 in channel 0)	V_{OL}	—	—	0.4	V	$I_{OL} = 15.0$ mA (ICFER.FMPE = 1)
			—	0.4	—	V	$I_{OL} = 20.0$ mA (ICFER.FMPE = 1)
	ETHERC output pin	V_{OL}	—	—	0.4	V	$I_{OL} = 1.0$ mA
Input leakage current	RES#, MD pin, EMLE*1, BSCANP*1, NMI	$ I_{in} $	—	—	1.0	μ A	$V_{in} = 0$ V $V_{in} = V_{CC}$
Three-state leakage current (off state)	Other than ports for 5 V tolerant	$ I_{TSL} $	—	—	1.0	μ A	$V_{in} = 0$ V $V_{in} = V_{CC}$
	Ports for 5 V tolerant		—	—	5.0		$V_{in} = 0$ V $V_{in} = 5.5$ V
Input pull-up resistor current	Other than P35	I_p	-300	—	-10	μ A	$V_{CC} = 2.7$ to 3.6 V $V_{in} = 0$ V
Input pull-down resistor current	EMLE, BSCANP	I_p	10	—	300	μ A	$V_{in} = V_{CC}$
Input capacitance	All input pins (except for P03, P05, P12, P13, P16, P17, P20, P21, EMLE, BSCANP, USB0_DP, and USB0_DM)	C_{in}	—	—	8	pF	$V_{bias} = 0$ V $V_{amp} = 20$ mV $f = 1$ MHz $T_a = 25^\circ$ C
	P03, P05, P12, P13, P16, P17, P20, P21, EMLE, BSCANP, USB0_DP, and USB0_DM		—	—	16		
Output voltage of the VCL pin		V_{CL}	—	1.18	—	V	

Note 1. The input leakage current value at the EMLE and BSCANP pins are only when $V_{in} = 0$ V.

Table 2.6 DC Characteristics (3)

Conditions: $V_{CC} = AVCC0 = AVCC1 = V_{CC_USB} = 2.7$ to 3.6 V, 2.7 V $\leq V_{REFH0} \leq AVCC0$,
 $V_{SS} = AVSS0 = AVSS1 = V_{REFL0} = V_{SS_USB} = 0$ V,
 $T_a = T_{opr}$

Item	Symbol	D version		G version		Unit	Test Conditions					
		Typ.	Max.	Typ.	Max.							
Supply current *1	Full operation*2	I_{CC}^{*3}	—	261	—	319	mA	ICLK = 240 MHz, PCLKA = 120 MHz, PCLKB = 60 MHz, PCLKC = 60 MHz, PCLKD = 60 MHz, FCLK = 60 MHz, BCLK = 120 MHz, BCLK pin = 60 MHz				
			Normal operation	Peripheral module clocks are supplied*4	61	—			61	—		
				Peripheral module clocks are stopped*4, *5	30	—			30	—		
			Core Mark	Peripheral module clocks are stopped*4, *5	37	—			37	—		
				Sleep mode: Peripheral module clocks are supplied*4	42	144			42	196		
			All module clock stop mode (reference value)		14	115			14	167		
			Increased by BGO operation*8	Reading from the code flash memory while the data flash memory is being programmed	6	—			6	—		
				Reading from the code flash memory while the code flash memory is being programmed	7	—			7	—		
			Increased by Trusted Secure IP operation		—	15			—	15		
			Low-speed operating mode 1: Peripheral module clocks are stopped*4		4.2	—			4.2	—	All clocks 1 MHz	
			Low-speed operating mode 2: Peripheral module clocks are stopped*4		4.2	—			4.2	—	All clocks 32.768 kHz	
			Software standby mode		3.95	107			3.95	155		
			Deep software standby mode	Power is supplied to the standby RAM and USB resume detecting unit (USB0 only)		15.5			70	15.5	98	μ A
				Power is not supplied to the standby RAM and USB resume detecting unit (USB0 only)	Low power consumption function of the power-on reset circuit is disabled*6	11.5			42	11.5	58	
Low power consumption function of the power-on reset circuit is enabled*7	4.9	32			4.9	47						
Increase current by operating RTC	When a low C_L crystal is in use	1		—	1	—						
	When a standard C_L crystal is in use	2		—	2	—						
When the RTC is operating while VCC is not supplied (Only the RTC and sub-clock oscillator operate with the battery backup function)	When a low C_L crystal is in use	0.9		—	0.9	—	$V_{BATT} = 2.0$ V, $V_{CC} = 0$ V					
		1.6		—	1.6	—	$V_{BATT} = 3.3$ V, $V_{CC} = 0$ V					
	When a standard C_L crystal is in use	1.7	—	1.7	—	$V_{BATT} = 2.0$ V, $V_{CC} = 0$ V						
		3.3	—	3.3	—	$V_{BATT} = 3.3$ V, $V_{CC} = 0$ V						
Inrush current on returning from deep software standby mode	Inrush current*9	I_{RUSH}	—	211	—	211	mA					

Note 1. Supply current values are measured when all output pins are unloaded and all input pull-up resistors are disabled.

Note 2. Peripheral module clocks are supplied.

Note 3. I_{CC} depends on the f (ICLK) as follows.

(when ICLK : PCLKA : PCLKB/PCLKC/PCLKD : BCLK : BCLK pin = 4 : 2 : 1 : 2 : 1 and EXTAL = 12 MHz)

- D version

I_{CC} max. = $0.62 \times f + 113$ (full operation in high-speed operating mode)

I_{CC} typ. = $0.22 \times f + 7$ (normal operation in high-speed operating mode)

I_{CC} typ. = $0.50 \times f + 3.7$ (ICLK 1 MHz max) (low-speed operating mode 1)

I_{CC} max. = $0.13 \times f + 113$ (sleep mode)

- G version
 $I_{CC} \text{ max.} = 0.65 \times f + 164$ (full operation in high-speed operating mode)
 $I_{CC} \text{ typ.} = 0.22 \times f + 7$ (normal operation in high-speed operating mode)
 $I_{CC} \text{ typ.} = 0.50 \times f + 3.7$ (ICLK 1 MHz max) (low-speed operating mode 1)
 $I_{CC} \text{ max.} = 0.13 \times f + 164$ (sleep mode)

Note 4. Whether the peripheral module clocks are supplied or stopped is controlled only by the bit settings in the module stop control registers A to D.

Note 5. When the peripheral module clock is stopped, the settings of the clock frequency are as follows:

ICLK = 240 MHz and PCLKA = PCLKB = PCLKC = PCLKD = FCLK = BCLK = BCLK pin = 3.75 MHz (divided by 64).

Note 6. When the low power consumption function is disabled, the DEEPCUT[1:0] bits are set to 01b.

Note 7. When the low power consumption function is enabled, the DEEPCUT[1:0] bits are set to 11b.

Note 8. These are the increases during programming of the code flash memory after the code flash memory (limitations apply to the combinations of address ranges of the program area and the readable area) or the data flash memory has been programmed or erased.

Note 9. Reference value

Table 2.7 DC Characteristics (4)

Conditions: $V_{CC} = AVCC0 = AVCC1 = VCC_USB = 2.7$ to 3.6 V, 2.7 V \leq VREFH0 \leq AVCC0,
 $V_{SS} = AVSS0 = AVSS1 = VREFL0 = VSS_USB = 0$ V,
 $T_a = T_{opr}$

Item		Symbol	D version			G version			Unit	Test Conditions	
			Min.	Typ.	Max.	Min.	Typ.	Max.			
Analog power supply current*1, *3	During 12-bit A/D conversion (unit 0)	I_{CC}	—	0.8	1	—	0.8	1	mA	IAVCC0_AD	
	During 12-bit A/D conversion (unit 0) with channel-dedicated sample-and-hold circuits (3 channels)		—	1.7	2.5	—	1.7	2.5		IAVCC0_AD + SH	
	During 12-bit A/D conversion (unit 1)		—	0.6	1	—	0.6	1		IAVCC1_AD	
	During 12-bit A/D conversion (unit 1) + temperature sensor		—	0.7	1.1	—	0.7	1.1		IAVCC1_AD + TEMP	
	During D/A conversion (2 channels)		Unbuffered output	—	0.25	0.4	—	0.25		0.4	IAVCC1_DA
			Buffered output	—	0.75	1.1	—	0.75		1.1	
	Waiting for A/D, D/A, and temperature sensor conversion (all units)		—	0.9	1.4	—	0.9	1.4	IAVCC0 + IAVCC1		
A/D, D/A, and temperature sensor are in standby mode (all units)	—	1.4	6.7	—	1.4	9.0	μ A	IAVCC0 + IAVCC1			
Reference power supply current	During 12-bit A/D conversion (unit 0)	I_{REFH}	—	38	60	—	38	60	μ A	IVREFH0	
	Waiting for 12-bit A/D conversion (unit 0)		—	0.07	0.5	—	0.07	0.6		IVREFH0	
	12-bit A/D converter in module stop mode (unit 0)		—	0.07	0.4	—	0.07	0.5		IVREFH0	
USB operating current	Low speed	USB0	$I_{CCUSBLS}$	—	3.7	6.5	—	3.7	6.5	mA	VCC_USB
	Full speed	USB0		$I_{CCUSBFS}$	—	4.2	10	—	4.2		10
RAM retention voltage		V_{RAM}	2.7	—	—	2.7	—	—	V		
VCC rising gradient		$SrVCC$	8.4	—	20000	8.4	—	20000	μ s/V		
VCC falling gradient*2		$SfVCC$	8.4	—	—	8.4	—	—	μ s/V		

Note 1. The reference power supply current is included in the power supply current value for 12-bit A/D converter (unit 1) and D/A converter.

Note 2. This applies when V_{BATT} is used.

Note 3. Supply current values are measured when all output pins are unloaded.

Table 2.8 Permissible Output Currents

Conditions: $V_{CC} = AVCC0 = AVCC1 = V_{CC_USB} = V_{BATT} = 2.7$ to 3.6 V, 2.7 V \leq $V_{REFH0} \leq AVCC0$,
 $V_{SS} = AVSS0 = AVSS1 = V_{REFL0} = V_{SS_USB} = 0$ V,
 $T_a = T_{opr}$

Item		Symbol	Min.	Typ.	Max.	Unit
Permissible output low current (average value per pin)	All output pins*1 Normal drive	I_{OL}	—	—	2.0	mA
	All output pins*2 High drive		—	—	3.8	
	All output pins*3 High-speed interface high-drive		—	—	7.5	
Permissible output low current (max. value per pin)	All output pins*1 Normal drive	I_{OL}	—	—	4.0	mA
	All output pins*2 High drive		—	—	7.6	
	All output pins*3 High-speed interface high-drive		—	—	15	
Permissible output low current (total)	Total of all output pins	ΣI_{OL}	—	—	80	mA
Permissible output high current (average value per pin)	All output pins*1 Normal drive	I_{OH}	—	—	-2.0	mA
	All output pins*2 High drive		—	—	-3.8	
	All output pins*3 High-speed interface high-drive		—	—	-7.5	
Permissible output high current (max. value per pin)	All output pins*1 Normal drive	I_{OH}	—	—	-4.0	mA
	All output pins*2 High drive		—	—	-7.6	
	All output pins*3 High-speed interface high-drive		—	—	-15	
Permissible output high current (total)	Total of all output pins	ΣI_{OH}	—	—	-80	mA

Caution: To protect the MCU's reliability, the output current values should not exceed the values in Table 2.8.

Note 1. This is the value when normal driving ability is set with a pin for which normal driving ability is selectable.

Note 2. This is the value when high driving ability is set with a pin for which normal driving ability is selectable or the value of the pin to which high driving ability is fixed.

Note 3. This is the value when high-speed interface high-driving ability is set with a pin for which high-speed interface high-driving ability is selectable.

Table 2.9 Thermal Resistance Value (Reference)

Item	Package	Symbol	Max.	Unit	Test Conditions
Thermal resistance	176-pin LQFP (PLQP0176KB-C)	θ_{ja}	31.5	°C/W	JESD51-2 and JESD51-7 compliant
	144-pin LQFP (PLQP0144KA-B)		32.6		
	100-pin LQFP (PLQP0100KB-B)		34.0		
	224-pin LFBGA (PLBG0224GA-A)		23.1		
	176-pin LFBGA (PLBG0176GA-A)		30.5		
	145-pin TFLGA (PTLG0145KA-A)		22.9		
	176-pin LQFP (PLQP0176KB-C)	Ψ_{jt}	0.4	°C/W	JESD51-2 and JESD51-7 compliant
	144-pin LQFP (PLQP0144KA-B)		0.5		
	100-pin LQFP (PLQP0100KB-B)		0.6		
	224-pin LFBGA (PLBG0224GA-A)		0.2		
	176-pin LFBGA (PLBG0176GA-A)		0.3		
	145-pin TFLGA (PTLG0145KA-A)		0.2		

Note: The values are reference values when the 4-layer board is used. Thermal resistance depends on the number of layers or size of the board. For details, refer to the JEDEC standards.

2.4 AC Characteristics

Table 2.10 Operating Frequency (High-Speed Operating Mode)

Conditions: $V_{CC} = AVCC0 = AVCC1 = V_{CC_USB} = V_{BATT} = 2.7$ to 3.6 V, 2.7 V $\leq V_{REFH0} \leq AVCC0$,
 $V_{SS} = AVSS0 = AVSS1 = V_{REFL0} = V_{SS_USB} = 0$ V,
 $T_a = T_{opr}$

Item		Symbol	Min.	Typ.	Max.	Unit	
Operating frequency	System clock (ICLK)	f	—	—	240	MHz	
	Peripheral module clock (PCLKA)		—	—	120		
	Peripheral module clock (PCLKB)		—	—	60		
	Peripheral module clock (PCLKC)		—	—	60		
	Peripheral module clock (PCLKD)		—	—	60		
	Flash-IF clock (FCLK)		—*1	—	60		
	External bus clock (BCLK)		Package of 144 pins or more	—	—		120
			100-pin package	—	—		60
	BCLK pin output		Package of 144 pins or more	—	—		80
			100-pin package	—	—		30
	SDRAM clock (SDCLK)		Package of 144 pins or more	—	—		80
SDCLK pin output	Package of 144 pins or more	—	—	80			

Note 1. The FCLK must run at a frequency of at least 4 MHz when changing the flash memory contents.

Table 2.11 Operating Frequency (Low-Speed Operating Mode 1)

Conditions: $V_{CC} = AVCC0 = AVCC1 = V_{CC_USB} = V_{BATT} = 2.7$ to 3.6 V, 2.7 V $\leq V_{REFH0} \leq AVCC0$,
 $V_{SS} = AVSS0 = AVSS1 = V_{REFL0} = V_{SS_USB} = 0$ V,
 $T_a = T_{opr}$

Item		Symbol	Min.	Typ.	Max.	Unit	
Operating frequency	System clock (ICLK)	f	—	—	1	MHz	
	Peripheral module clock (PCLKA)		—	—	1		
	Peripheral module clock (PCLKB)		—	—	1		
	Peripheral module clock (PCLKC)*1		—	—	1		
	Peripheral module clock (PCLKD)*1		—	—	1		
	Flash-IF clock (FCLK)		—	—	1		
	External bus clock (BCLK)		—	—	1		
	BCLK pin output		—	—	1		
	SDRAM clock (SDCLK)		Package of 144 pins or more	—	—		1
	SDCLK pin output		Package of 144 pins or more	—	—		1

Note 1. When the 12-bit A/D converter is used, the frequency must be set to at least 1 MHz.

Table 2.12 Operating Frequency (Low-Speed Operating Mode 2)

Conditions: $V_{CC} = AVCC0 = AVCC1 = VCC_USB = V_{BATT} = 2.7$ to 3.6 V, 2.7 V $\leq VREFH0 \leq AVCC0$,
 $VSS = AVSS0 = AVSS1 = VREFL0 = VSS_USB = 0$ V,
 $T_a = T_{opr}$

Item		Symbol	Min.	Typ.	Max.	Unit	
Operating frequency	System clock (ICKL)	f	32	—	264	kHz	
	Peripheral module clock (PCLKA)		—	—	264		
	Peripheral module clock (PCLKB)		—	—	264		
	Peripheral module clock (PCLKC)*1		—	—	264		
	Peripheral module clock (PCLKD)*1		—	—	264		
	Flash-IF clock (FCLK)		32	—	264		
	External bus clock (BCLK)		—	—	264		
	BCLK pin output		—	—	264		
	SDRAM clock (SDCLK)		Package of 144 pins or more	—	—		264
	SDCLK pin output		Package of 144 pins or more	—	—		264

Note 1. The 12-bit A/D converter cannot be used.

2.4.1 Reset Timing

Table 2.13 Reset Timing

Conditions: $VCC = AVCC0 = AVCC1 = VCC_USB = V_{BATT} = 2.7$ to 3.6 V, 2.7 V \leq $VREFH0 \leq AVCC0$,
 $VSS = AVSS0 = AVSS1 = VREFL0 = VSS_USB = 0$ V,
 $T_a = T_{opr}$

Item		Symbol	Min.	Typ.	Max.	Unit	Test Conditions
RES# pulse width	Power-on	t_{RESWP}	1	—	—	ms	Figure 2.1
	Deep software standby mode	t_{RESWD}	0.6	—	—	ms	Figure 2.2
	Software standby mode, low-speed operating mode 2	t_{RESWS}	0.3	—	—	ms	
	Programming or erasure of the code flash memory, or programming, erasure or blank checking of the data flash memory	t_{RESWF}	200	—	—	μ s	
	Other than above	t_{RESW}	200	—	—	μ s	
Waiting time after release from the RES# pin reset		t_{RESWT}	54	—	55	t_{Lcyc}	Figure 2.1
Internal reset time (independent watchdog timer reset, watchdog timer reset, software reset)		t_{RESW2}	100	—	108	t_{Lcyc}	

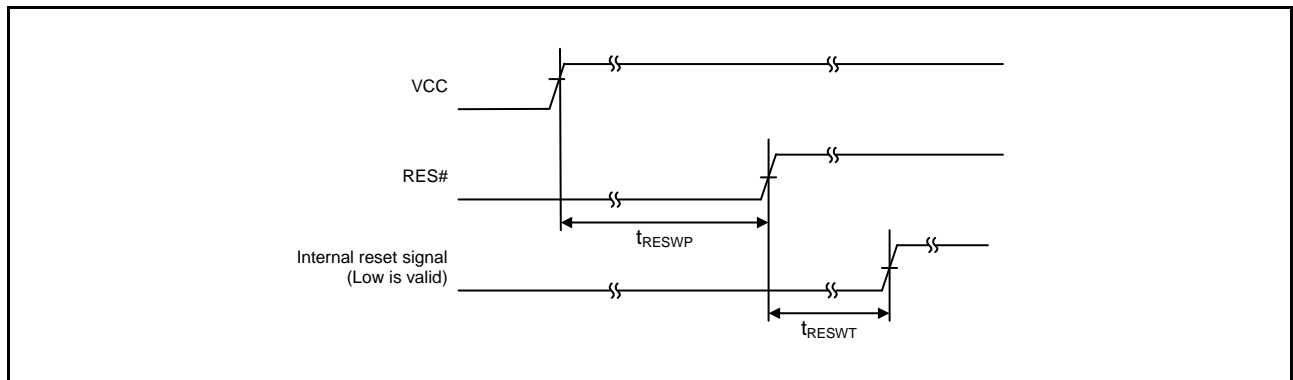

Figure 2.1 Reset Input Timing at Power-On

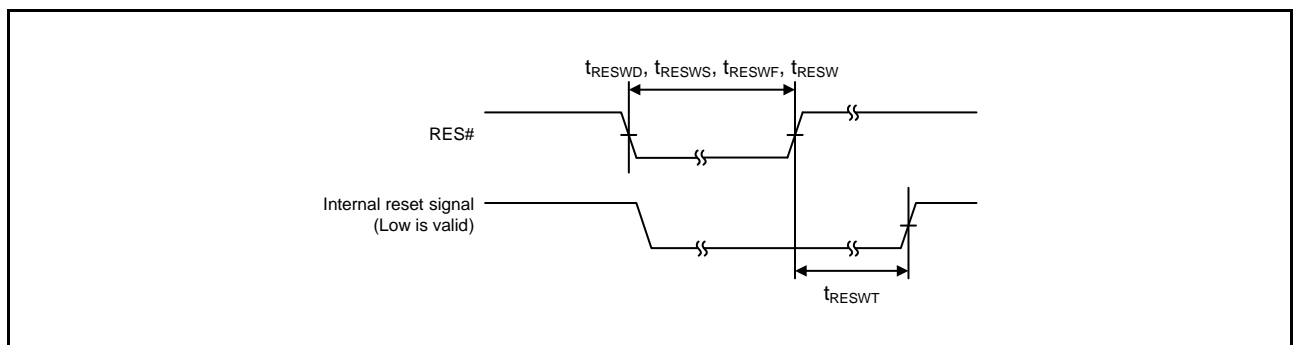

Figure 2.2 Reset Input Timing

2.4.2 Clock Timing

Table 2.14 BCLK Pin Output, SDCLK Pin Output Clock Timing

Conditions: $V_{CC} = AV_{CC0} = AV_{CC1} = V_{CC_USB} = V_{BATT} = 2.7$ to 3.6 V, 2.7 V $\leq V_{REFH0} \leq AV_{CC0}$,
 $V_{SS} = AV_{SS0} = AV_{SS1} = V_{REFL0} = V_{SS_USB} = 0$ V,
 $T_a = T_{opr}$

Item	Symbol	Min.	Typ.	Max.	Unit	Test Conditions
BCLK pin output cycle time	t_{Bcyc}	12.5	—	—	ns	Figure 2.3
		33.2	—	—		
BCLK pin output high pulse width	t_{CH}	3.25	—	—	ns	
BCLK pin output low pulse width	t_{CL}	3.25	—	—	ns	
BCLK pin output rising time	t_{Cr}	—	—	3	ns	
BCLK pin output falling time	t_{Cf}	—	—	3	ns	
SDCLK pin output cycle time	t_{Bcyc}	12.5	—	—	ns	
SDCLK pin output high pulse width		t_{CH}	3.25	—	—	ns
SDCLK pin output low pulse width		t_{CL}	3.25	—	—	ns
SDCLK pin output rising time		t_{Cr}	—	—	3	ns
SDCLK pin output falling time		t_{Cf}	—	—	3	ns

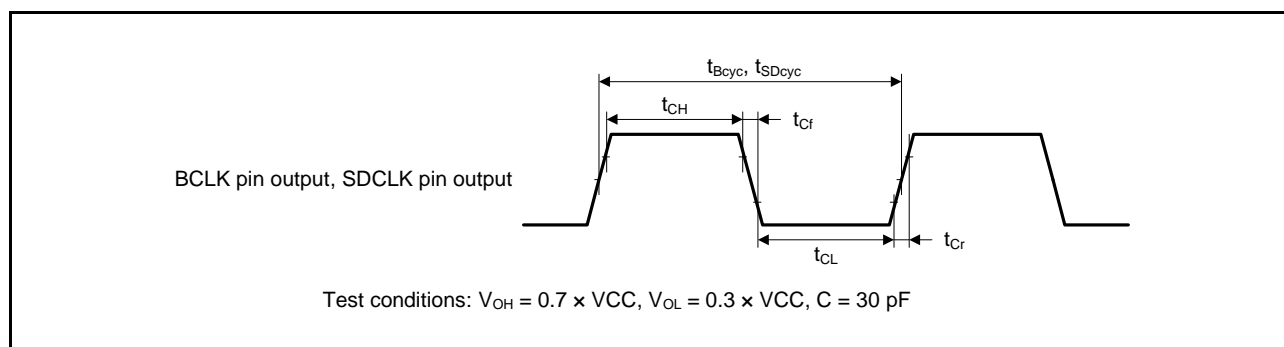

Figure 2.3 BCLK Pin and SDCLK Pin Output Timing

Table 2.15 EXTAL Clock Timing

Conditions: $VCC = AVCC0 = AVCC1 = VCC_USB = V_{BATT} = 2.7$ to 3.6 V, 2.7 V \leq $VREFH0 \leq AVCC0$,
 $VSS = AVSS0 = AVSS1 = VREFL0 = VSS_USB = 0$ V,
 $T_a = T_{opr}$

Item	Symbol	$f_{EXMAIN} \leq 24$ MHz			$f_{EXMAIN} > 24$ MHz			Unit	Test Conditions
		Min.	Typ.	Max.	Min.	Typ.	Max.		
EXTAL external clock input cycle time	t_{EXcyc}	41.66	—	—	33.33	—	—	ns	Figure 2.4
EXTAL external clock input frequency	f_{EXMAIN}	—	—	24	—	—	30	MHz	
EXTAL external clock input high pulse width	t_{EXH}	15.83	—	—	13.33	—	—	ns	
EXTAL external clock input low pulse width	t_{EXL}	15.83	—	—	13.33	—	—	ns	
EXTAL external clock rising time	t_{EXr}	—	—	5	—	—	5	ns	
EXTAL external clock falling time	t_{EXf}	—	—	5	—	—	5	ns	

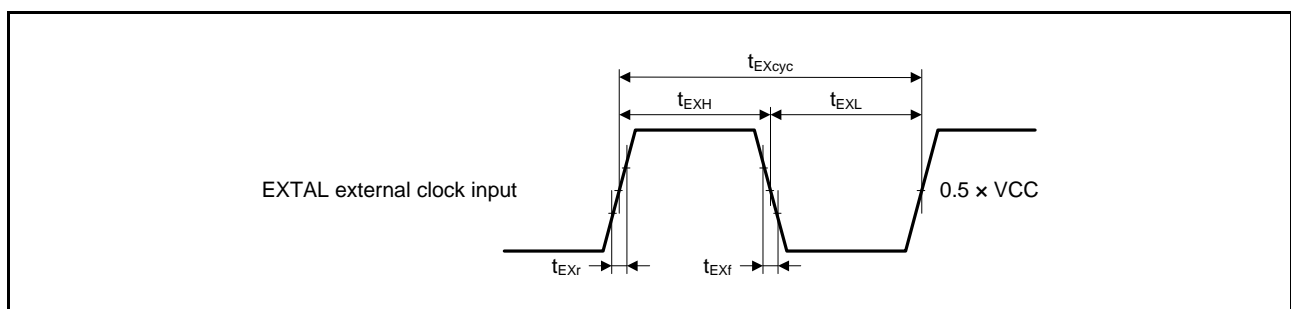

Figure 2.4 EXTAL External Clock Input Timing

Table 2.16 Main Clock Timing

Conditions: $VCC = AVCC0 = AVCC1 = VCC_USB = V_{BATT} = 2.7$ to 3.6 V, 2.7 V \leq $VREFH0 \leq AVCC0$,
 $VSS = AVSS0 = AVSS1 = VREFL0 = VSS_USB = 0$ V,
 $T_a = T_{opr}$

Item	Symbol	Min.	Typ.	Max.	Unit	Test Conditions
Main clock oscillation frequency	f_{MAIN}	8	—	24	MHz	
Main clock oscillator stabilization time (crystal)	$t_{MAINOSC}$	—	—	—*1	ms	Figure 2.5
Main clock oscillator stabilization wait time (crystal)	$t_{MAINOSCWT}$	—	—	—*2	ms	

Note 1. When using a main clock, ask the manufacturer of the oscillator to evaluate its oscillation. Refer to the results of evaluation provided by the manufacturer for the oscillation stabilization time.

Note 2. The number of cycles selected by the value of the MOSCWTCR.MSTS[7:0] bits determines the main clock oscillation stabilization wait time in accord with the formula below.

$$t_{MAINOSCWT} = [(MSTS[7:0] \text{ bits} \times 32) + 10] / f_{LOCO}$$

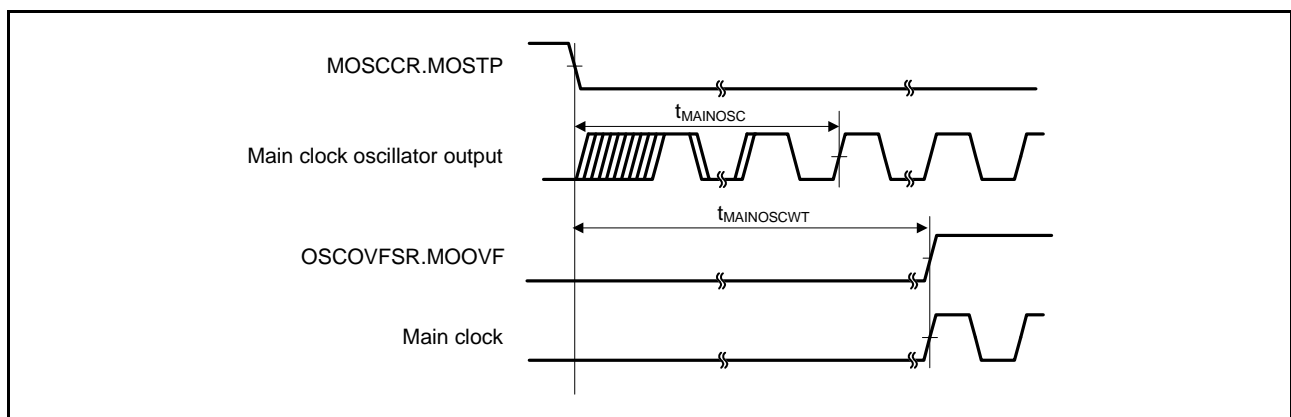

Figure 2.5 Main Clock Oscillation Start Timing

Table 2.17 LOCO and IWDT-Dedicated Low-Speed Clock Timing

Conditions: $V_{CC} = AVCC0 = AVCC1 = VCC_USB = V_{BATT} = 2.7$ to 3.6 V, 2.7 V $\leq VREFH0 \leq AVCC0$,
 $VSS = AVSS0 = AVSS1 = VREFL0 = VSS_USB = 0$ V,
 $T_a = T_{opr}$

Item	Symbol	Min.	Typ.	Max.	Unit	Test Conditions
LOCO clock cycle time	t_{Lcyc}	4.63	4.16	3.78	μ s	
LOCO clock oscillation frequency	f_{LOCO}	216	240	264	kHz	
LOCO clock oscillation stabilization wait time	t_{LOCOWT}	—	—	44	μ s	Figure 2.6
IWDT-dedicated low-speed clock cycle time	t_{iLcyc}	9.26	8.33	7.57	μ s	
IWDT-dedicated low-speed clock oscillation frequency	f_{iLOCO}	108	120	132	kHz	
IWDT-dedicated low-speed clock oscillation stabilization wait time	$t_{iLOCOWT}$	—	142	190	μ s	Figure 2.7

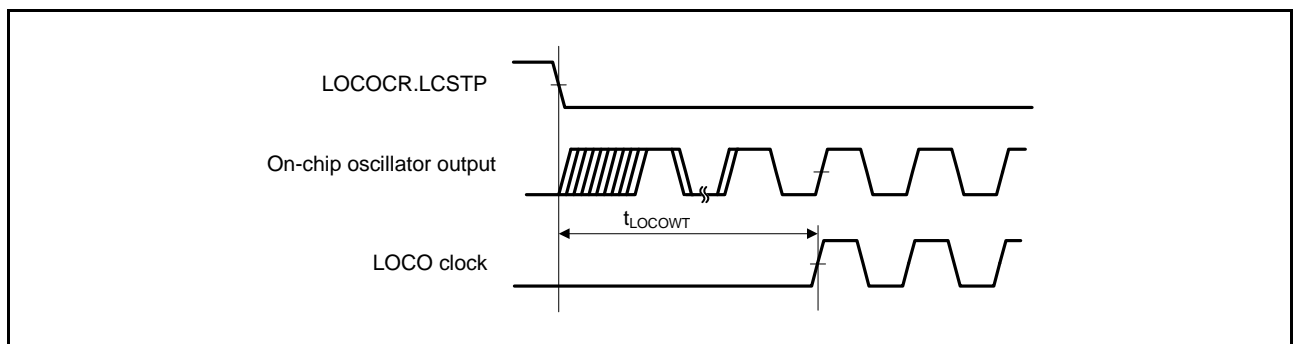

Figure 2.6 LOCO Clock Oscillation Start Timing

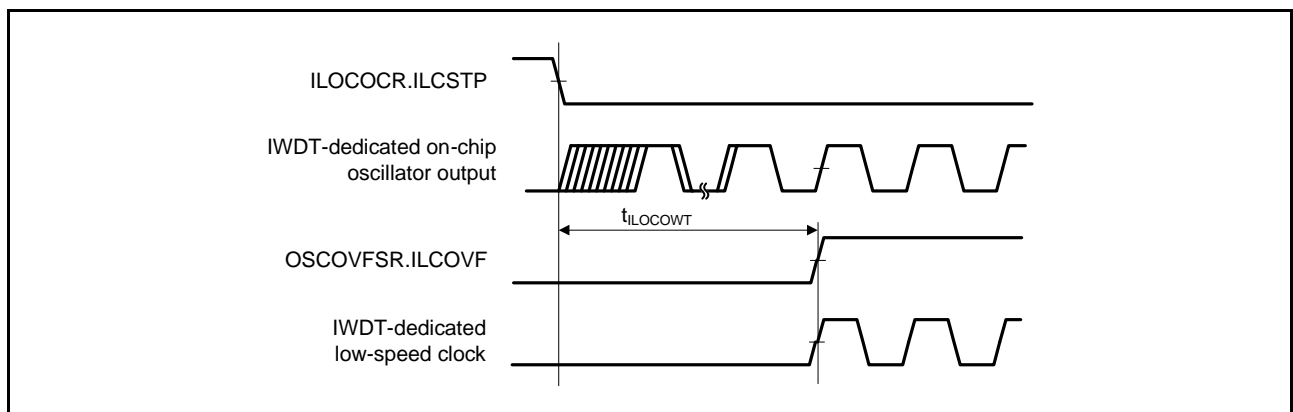

Figure 2.7 IWDT-dedicated Low-Speed Clock Oscillation Start Timing

Table 2.18 HOCO Clock Timing

Conditions: $V_{CC} = AV_{CC0} = AV_{CC1} = V_{CC_USB} = V_{BATT} = 2.7$ to 3.6 V, 2.7 V $\leq V_{REFH0} \leq AV_{CC0}$,
 $V_{SS} = AV_{SS0} = AV_{SS1} = V_{REFL0} = V_{SS_USB} = 0$ V,
 $T_a = T_{opr}$

Item	Symbol	Min.	Typ.	Max.	Unit	Test Conditions
HOCO clock oscillation frequency	f_{HOCO}	15.61	16	16.39	MHz	$T_a \geq -20^\circ\text{C}$
		17.56	18	18.44		
		19.52	20	20.48		
		15.52	16	16.48		$-40^\circ\text{C} \leq T_a < -20^\circ\text{C}$
		17.46	18	18.54		
		19.4	20	20.6		
HOCO clock oscillation stabilization wait time	t_{HOCOWT}	—	105	149	μs	Figure 2.8
HOCO clock power supply stabilization time	t_{HOCOP}	—	—	150	μs	Figure 2.9

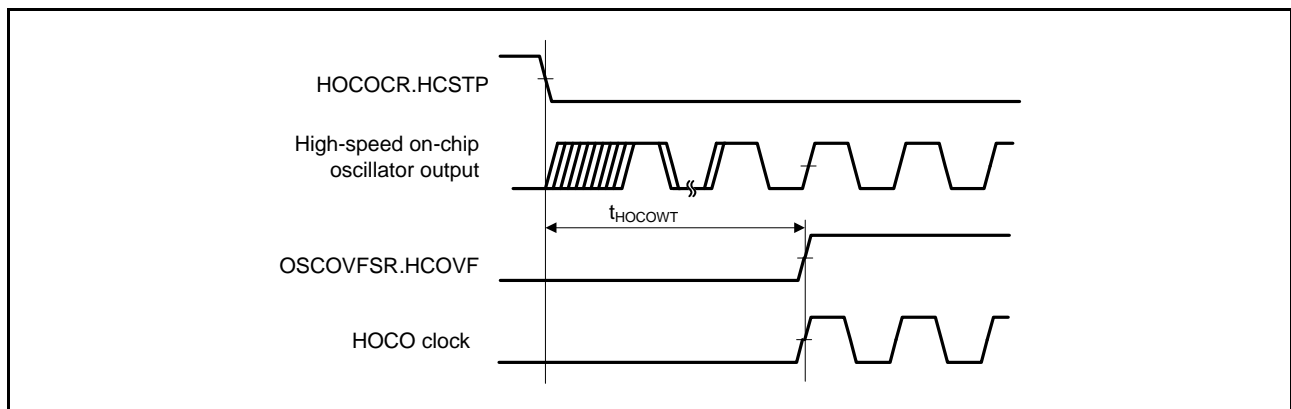

Figure 2.8 HOCO Clock Oscillation Start Timing (Oscillation is Started by Setting the HOCOCR.HCSTP Bit)

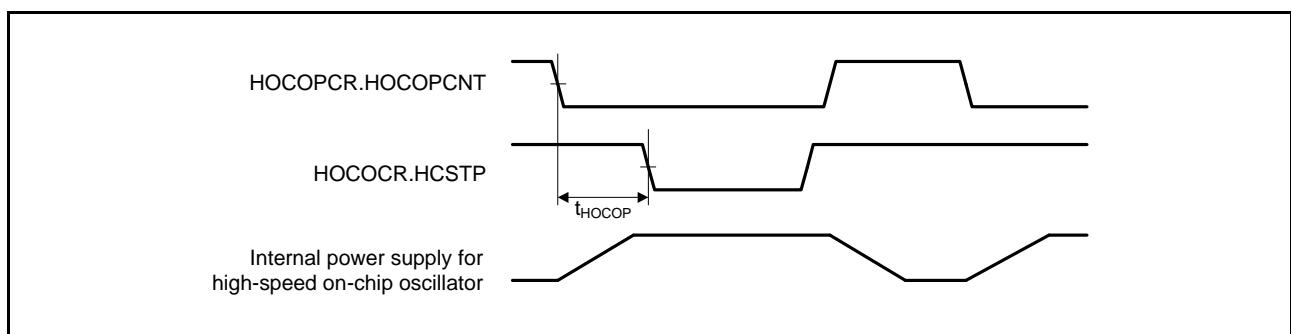

Figure 2.9 High-Speed On-Chip Oscillator Power Supply Control Timing

Table 2.19 PLL/PPLL Clock Timing

Conditions: $V_{CC} = AVCC0 = AVCC1 = VCC_USB = V_{BATT} = 2.7$ to 3.6 V, 2.7 V $\leq VREFH0 \leq AVCC0$,
 $VSS = AVSS0 = AVSS1 = VREFL0 = VSS_USB = 0$ V,
 $T_a = T_{opr}$

Item	Symbol	Min.	Typ.	Max.	Unit	Test Conditions
PLL/PPLL clock oscillation frequency	f_{PLL}	120	—	240	MHz	
PLL/PPLL clock oscillation stabilization wait time	t_{PLLWT}	—	259	320	μ s	Figure 2.10

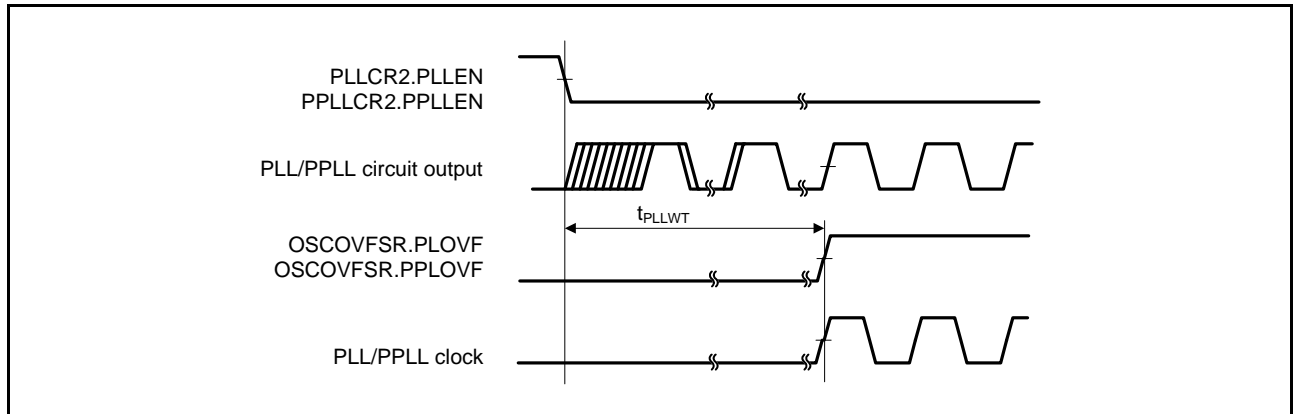

Figure 2.10 PLL/PPLL Clock Oscillation Start Timing

Table 2.20 Sub-Clock Timing

Conditions: $V_{CC} = AVCC0 = AVCC1 = VCC_USB = 2.7$ to 3.6 V, 2.7 V $\leq VREFH0 \leq AVCC0$,
 $VSS = AVSS0 = AVSS1 = VREFL0 = VSS_USB = 0$ V,
 $V_{BATT} = 2.0$ to 3.6 V, $T_a = T_{opr}$

Item	Symbol	Min.	Typ.	Max.	Unit	Test Conditions
Sub-clock oscillation frequency	f_{SUB}	—	32.768	—	kHz	
Sub-clock oscillation stabilization time	t_{SUBOSC}	—	—	*1	s	Figure 2.11
Sub-clock oscillation stabilization wait time	$t_{SUBOSCWT}$	—	—	*2	s	

Note 1. When using a sub-clock, ask the manufacturer of the oscillator to evaluate its oscillation. Refer to the results of evaluation provided by the manufacturer for the oscillation stabilization time.

Note 2. The number of cycles selected by the value of the $SOSCWTCR.SSTS[7:0]$ bits determines the sub-clock oscillation stabilization wait time in accord with the formula below.

$$t_{SUBOSCWT} = [(SSTS[7:0] \text{ bits} \times 16384) + 10] / f_{Loco}$$

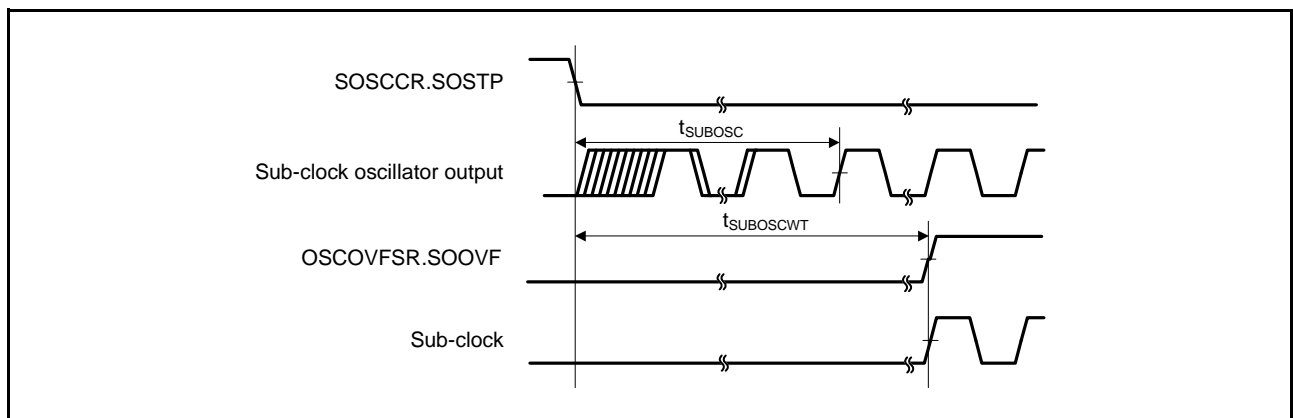

Figure 2.11 Sub-Clock Oscillation Start Timing

Table 2.21 CLKOUT Pin Output Timing

Conditions: $V_{CC} = AVCC0 = AVCC1 = VCC_USB = 2.7$ to 3.6 V, 2.7 V \leq $V_{REFH0} \leq AVCC0$,
 $V_{SS} = AVSS0 = AVSS1 = V_{REFL0} = VSS_USB = 0$ V,
 $V_{BATT} = 2.0$ to 3.6 V, $T_a = T_{opr}$,
 High-drive output is selected by the driving ability control register

Item	Symbol	Min.	Typ.	Max.	Unit	Test Conditions
CLKOUT pin output cycle time	t_{Cyc}	25	—	—	ns	Figure 2.12 $t_{Cyc} = 25$ ns
CLKOUT pin output high pulse width*1	t_{CH}	5	—	—	ns	
CLKOUT pin output low pulse width*1	t_{CL}	5	—	—	ns	
CLKOUT pin output rising time	t_{Cr}	—	—	5	ns	
CLKOUT pin output falling time	t_{Cf}	—	—	5	ns	

Note 1. If the main clock oscillator is selected by the CLKOUT output source select bit (CKOCR.CKOSEL[2:0]) and the external clock input is selected by the main clock oscillator switching bit (MOFCR.MOSEL), the pulse width depends on the input clock wave form.

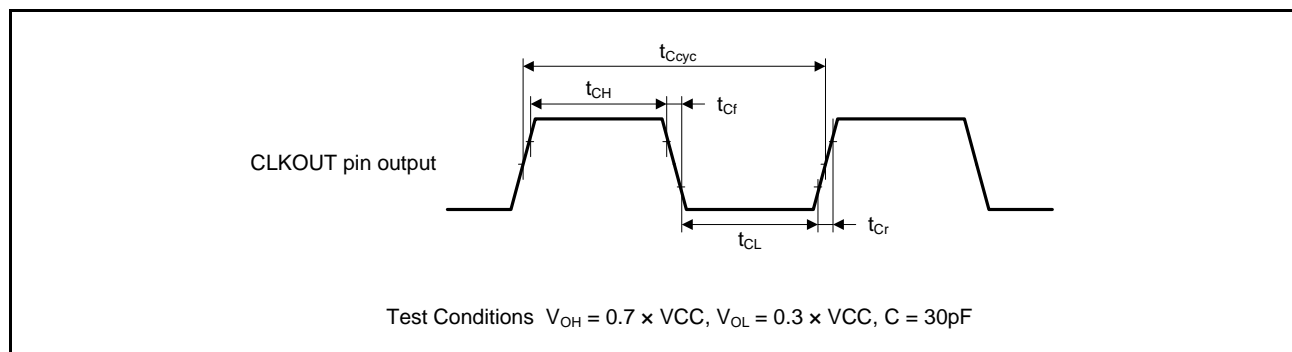
**Figure 2.12 CLKOUT Pin Output Timing****Table 2.22 CLKOUT25M Pin Output Timing**

Conditions: $V_{CC} = AVCC0 = AVCC1 = VCC_USB = 2.7$ to 3.6 V, 2.7 V \leq $V_{REFH0} \leq AVCC0$,
 $V_{SS} = AVSS0 = AVSS1 = V_{REFL0} = VSS_USB = 0$ V,
 $V_{BATT} = 2.0$ to 3.6 V, $T_a = T_{opr}$,
 High-speed interface high-drive is selected by the driving ability control register

Item	Symbol	Min.	Typ.	Max.	Unit	Test Conditions
CLKOUT25M pin output cycle time	t_{Cyc}	—	40	—	ns	Figure 2.13
CLKOUT25M pin output high pulse width	t_{CH}	13	—	—	ns	
CLKOUT25M pin output low pulse width	t_{CL}	13	—	—	ns	
CLKOUT25M pin output rising time	t_{Cr}	—	—	3	ns	
CLKOUT25M pin output falling time	t_{Cf}	—	—	3	ns	

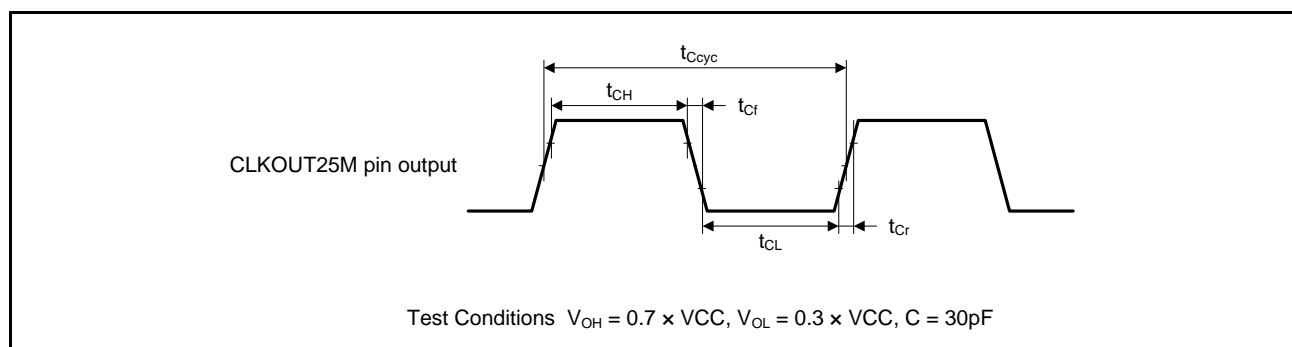
**Figure 2.13 CLKOUT25M Pin Output Timing**

2.4.3 Timing of Recovery from Low Power Consumption Modes

Table 2.23 Timing of Recovery from Low Power Consumption Modes (1)

Conditions: $V_{CC} = AV_{CC0} = AV_{CC1} = V_{CC_USB} = V_{BATT} = 2.7$ to 3.6 V, 2.7 V $\leq V_{REFH0} \leq AV_{CC0}$,
 $V_{SS} = AV_{SS0} = AV_{SS1} = V_{REFL0} = V_{SS_USB} = 0$ V,
 $T_a = T_{opr}$

Item	Symbol	Min.	Typ.	Max.		Unit	Test Conditions		
				$t_{SBYOSCWT}^{*2}$	t_{SBYSEQ}^{*3}				
Recovery time from software standby mode*1	Crystal resonator connected to main clock oscillator	Main clock oscillator operating	t_{SBYMC}	—	—	$\{(MSTS[7:0] \text{ bit} \times 32) + 76\} / 0.216$	$100 + 7 / f_{ICLK} + 2n / f_{MAIN}$	μs	Figure 2.14
		Main clock oscillator and PLL circuit operating	t_{SBYPC}	—	—	$\{(MSTS[7:0] \text{ bit} \times 32) + 138\} / 0.216$	$100 + 7 / f_{ICLK} + 2n / f_{PLL}$		
	External clock input to main clock oscillator	Main clock oscillator operating	t_{SBYEX}	—	—	352	$100 + 7 / f_{ICLK} + 2n / f_{EXMAIN}$		
		Main clock oscillator and PLL circuit operating	t_{SBYPE}	—	—	639	$100 + 7 / f_{ICLK} + 2n / f_{PLL}$		
	Sub-clock oscillator operating		t_{SBYSC}	—	—	$\{(SSTS[7:0] \text{ bit} \times 16384) + 13\} / 0.216 + 10 / f_{FCLK}$	$100 + 4 / f_{ICLK} + 2n / f_{SUE}$		
	High-speed on-chip oscillator operating	High-speed on-chip oscillator operating	t_{SBYHO}	—	—	454	$100 + 7 / f_{ICLK} + 2n / f_{HOCO}$		
		High-speed on-chip oscillator operating and PLL circuit operating	t_{SBYPH}	—	—	741	$100 + 7 / f_{ICLK} + 2n / f_{PLL}$		
	Low-speed on-chip oscillator operating*4		t_{SBYLO}	—	—	338	$100 + 7 / f_{ICLK} + 2n / f_{LOCO}$		

Note 1. The time for recovery from software standby mode is determined by the value obtained by adding the oscillation stabilization waiting time ($t_{SBYOSCWT}$) and the time required for operations by the software standby release sequencer (t_{SBYSEQ}).

Note 2. When several oscillators were running before the transition to software standby, the greatest value of the oscillation stabilization waiting time $t_{SBYOSCWT}$ is selected.

Note 3. For n, the greatest value is selected from among the internal clock division settings.

Note 4. This condition applies when $f_{ICLK}:f_{FCLK} = 1:1, 2:1, \text{ or } 4:1$.

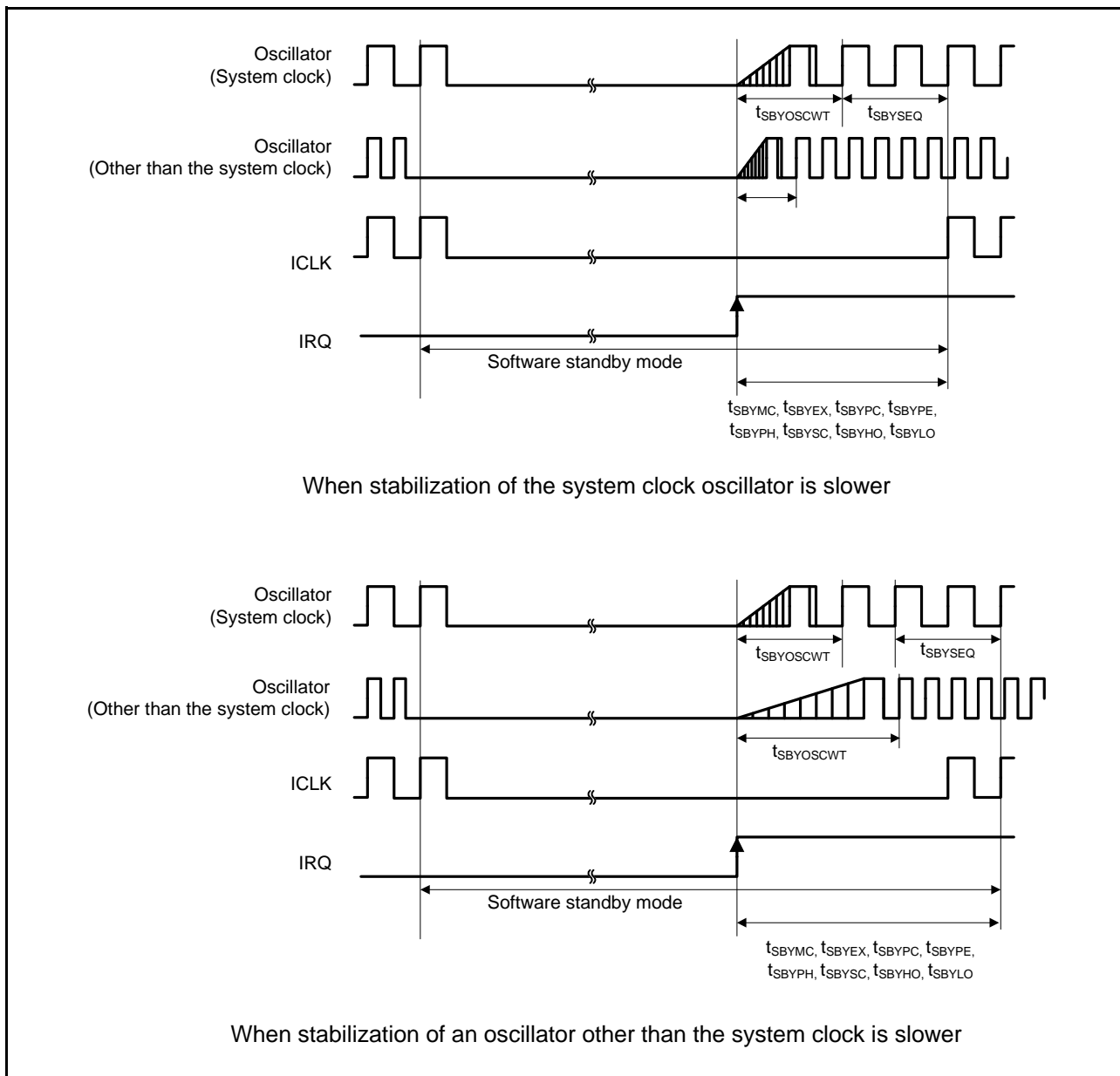

Figure 2.14 Software Standby Mode Recovery Timing

Table 2.24 Timing of Recovery from Low Power Consumption Modes (2)

Conditions: $VCC = AVCC0 = AVCC1 = VCC_USB = V_{BATT} = 2.7$ to 3.6 V, 2.7 V \leq $VREFH0 \leq AVCC0$,
 $VSS = AVSS0 = AVSS1 = VREFL0 = VSS_USB = 0$ V,
 $T_a = T_{opr}$

Item	Symbol	Min.	Typ.	Max.	Unit	Test Conditions
Recovery time from deep software standby mode	t_{DSBY}	—	—	0.9	ms	Figure 2.15
Wait time after recovery from deep software standby mode	t_{DSBYWT}	23	—	24	t_{Lcyc}	

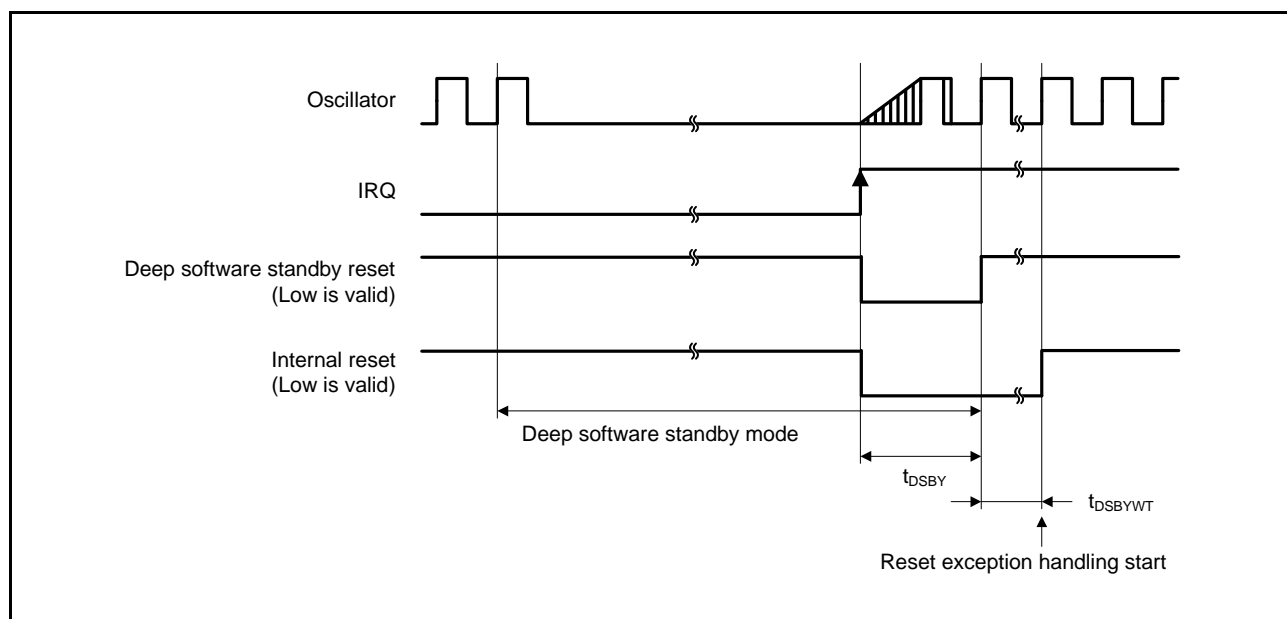

Figure 2.15 Deep Software Standby Mode Recovery Timing

2.4.4 Control Signal Timing

Table 2.25 Control Signal Timing

Conditions: $VCC = AVCC0 = AVCC1 = VCC_USB = V_{BATT} = 2.7$ to 3.6 V, 2.7 V $\leq VREFH0 \leq AVCC0$,
 $VSS = AVSS0 = AVSS1 = VREFL0 = VSS_USB = 0$ V,
 $PCLKB = 8$ to 60 MHz, $T_a = T_{opr}$

Item	Symbol	Min.*1	Typ.	Max.	Unit	Test Conditions*1
NMI pulse width	t_{NMIW}	200	—	—	ns	$t_{PBcyc} \times 2 \leq 200$ ns, Figure 2.16
		$t_{PBcyc} \times 2$	—	—		$t_{PBcyc} \times 2 > 200$ ns, Figure 2.16
IRQ pulse width	t_{IRQW}	200	—	—	ns	$t_{PBcyc} \times 2 \leq 200$ ns, Figure 2.17
		$t_{PBcyc} \times 2$	—	—		$t_{PBcyc} \times 2 > 200$ ns, Figure 2.17

Note 1. t_{PBcyc} : PCLKB cycle

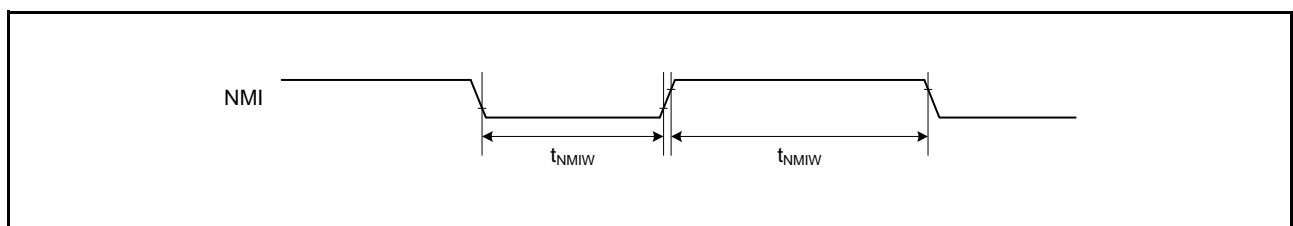

Figure 2.16 NMI Interrupt Input Timing

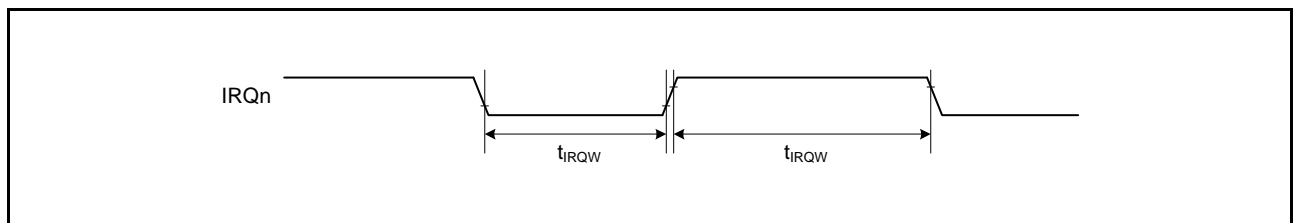

Figure 2.17 IRQ Interrupt Input Timing

2.4.5 Bus Timing

Table 2.26 Bus Timing

Conditions 1: $V_{CC} = AVCC0 = AVCC1 = V_{CC_USB} = V_{BATT} = 2.7$ to 3.6 V, 2.7 V $\leq V_{REFH0} \leq AVCC0$,
 $V_{SS} = AVSS0 = AVSS1 = V_{REFL0} = V_{SS_USB} = 0$ V,
 $ICLK = 8$ to 240 MHz, $PCLKA = 8$ to 120 MHz, $PCLKB = BCLK = SDCLK = 8$ to 60 MHz, $T_a = T_{opr}$,
 Output load conditions: $V_{OH} = 0.5 \times V_{CC}$, $V_{OL} = 0.5 \times V_{CC}$, $C = 30$ pF,
 High-drive output is selected by the driving ability control register.

Conditions 2: $V_{CC} = AVCC0 = AVCC1 = V_{CC_USB} = V_{BATT} = 3.0$ to 3.6 V, 3.0 V $\leq V_{REFH0} \leq AVCC0$,
 $V_{SS} = AVSS0 = AVSS1 = V_{REFL0} = V_{SS_USB} = 0$ V,
 $ICLK = 60$ to 240 MHz, $PCLKA = 8$ to 120 MHz, $PCLKB = 8$ to 60 MHz, 60 MHz $< BCLK = SDCLK \leq 80$ MHz,
 $T_a = T_{opr}$,
 Output load conditions: $V_{OH} = 0.5 \times V_{CC}$, $V_{OL} = 0.5 \times V_{CC}$,
 $C = 15$ pF for the SDCLK pin, $C = 30$ pF for other pins.

To control the drive capacity when using the SDRAM: set the PFBCR3.SDCLKDRV bit in external bus control register 1 to 1 to select the drive capacity of the SDCLK pin, and set the SDRAM pins other than the SDCLK pin as high-speed-interface driving outputs.

Item	Symbol	Conditions 1		Conditions 2		Unit	Test Conditions
		Min.	Max.	Min.	Max.		
Address delay time	t_{AD}	—	12.5	—	12.5	ns	Figure 2.18 to Figure 2.23
Byte control delay time	t_{BCD}	—	12.5	—	12.5	ns	
CS# delay time	t_{CSD}	—	12.5	—	12.5	ns	
ALE delay time	t_{ALED}	—	12.5	—	12.5	ns	
RD# delay time	t_{RSD}	—	12.5	—	12.5	ns	
Read data setup time	t_{RDS}	12.5	—	12.5	—	ns	
Read data hold time	t_{RDH}	0	—	0	—	ns	
WR# delay time	t_{WRD}	—	12.5	—	12.5	ns	
Write data delay time	t_{WDD}	—	12.5	—	12.5	ns	
Write data hold time	t_{WDH}	0	—	0	—	ns	
WAIT# setup time	t_{WTS}	12.5	—	12.5	—	ns	
WAIT# hold time	t_{WTH}	0	—	0	—	ns	
Address delay time 2 (SDRAM)	t_{AD2}	1	12.5	1	10.0	ns	Figure 2.25 to Figure 2.31
CS# delay time 2 (SDRAM)	t_{CSD2}	1	12.5	1	10.0	ns	
DQM delay time (SDRAM)	t_{DQMD}	1	12.5	1	10.0	ns	
CKE delay time (SDRAM)	t_{CKED}	1	12.5	1	10.0	ns	
Read data setup time 2 (SDRAM)	t_{RDS2}	10	—	6.0	—	ns	
Read data hold time 2 (SDRAM)	t_{RDH2}	0	—	0	—	ns	
Write data delay time 2 (SDRAM)	t_{WDD2}	—	12.5	—	10.0	ns	
Write data hold time 2 (SDRAM)	t_{WDH2}	1	—	1	—	ns	
WE# delay time (SDRAM)	t_{WED}	1	12.5	1	10.0	ns	
RAS# delay time (SDRAM)	t_{RASD}	1	12.5	1	10.0	ns	
CAS# delay time (SDRAM)	t_{CASD}	1	12.5	1	10.0	ns	

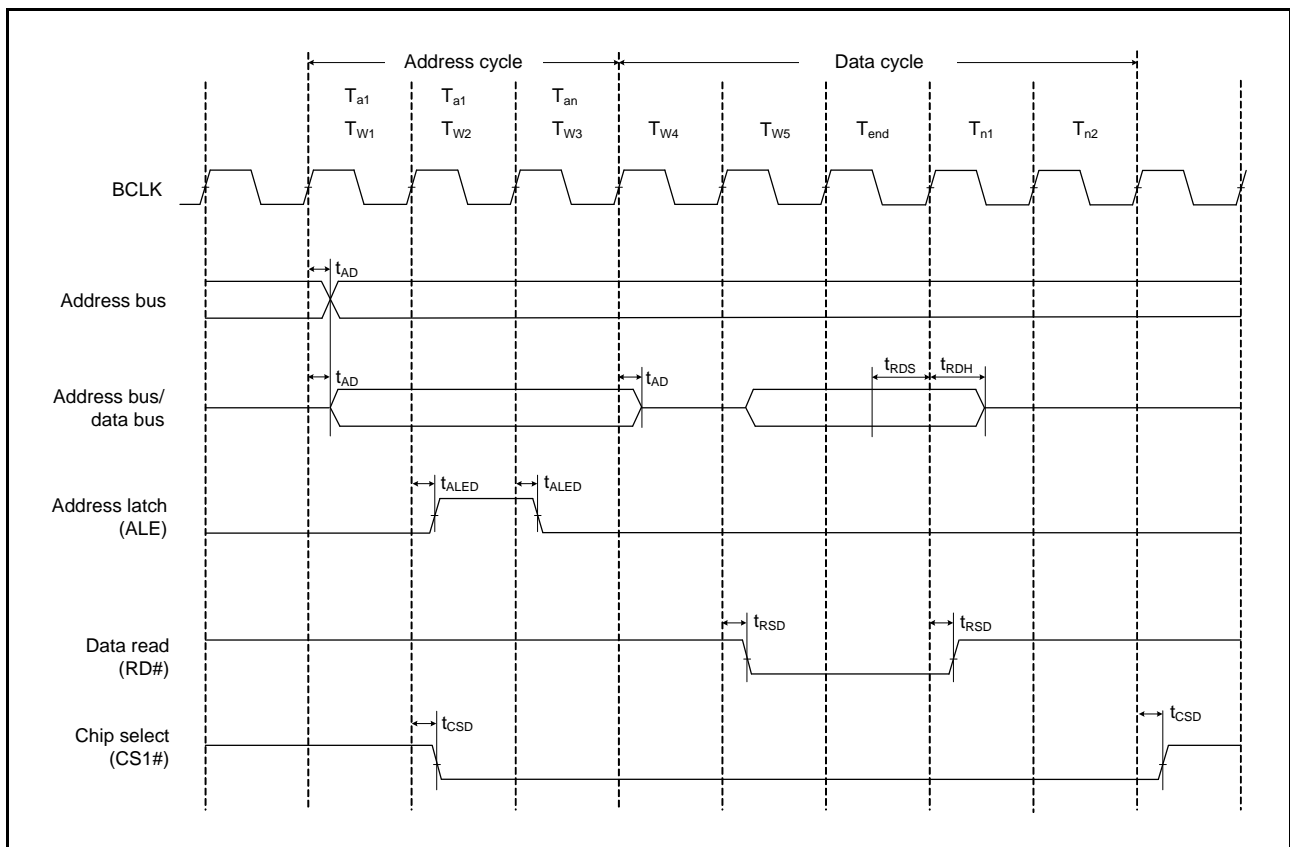

Figure 2.18 Address/Data Multiplexed Bus Read Access Timing

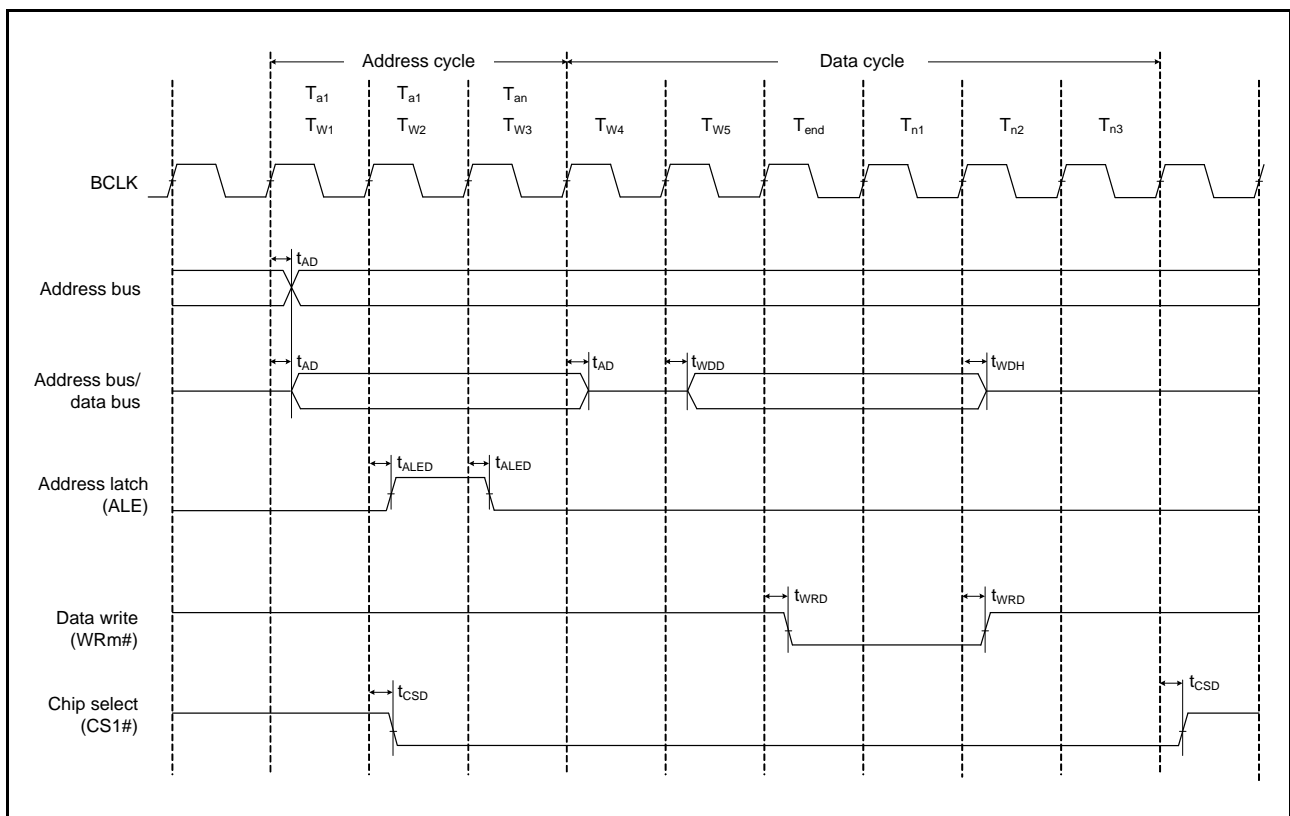

Figure 2.19 Address/Data Multiplexed Bus Write Access Timing

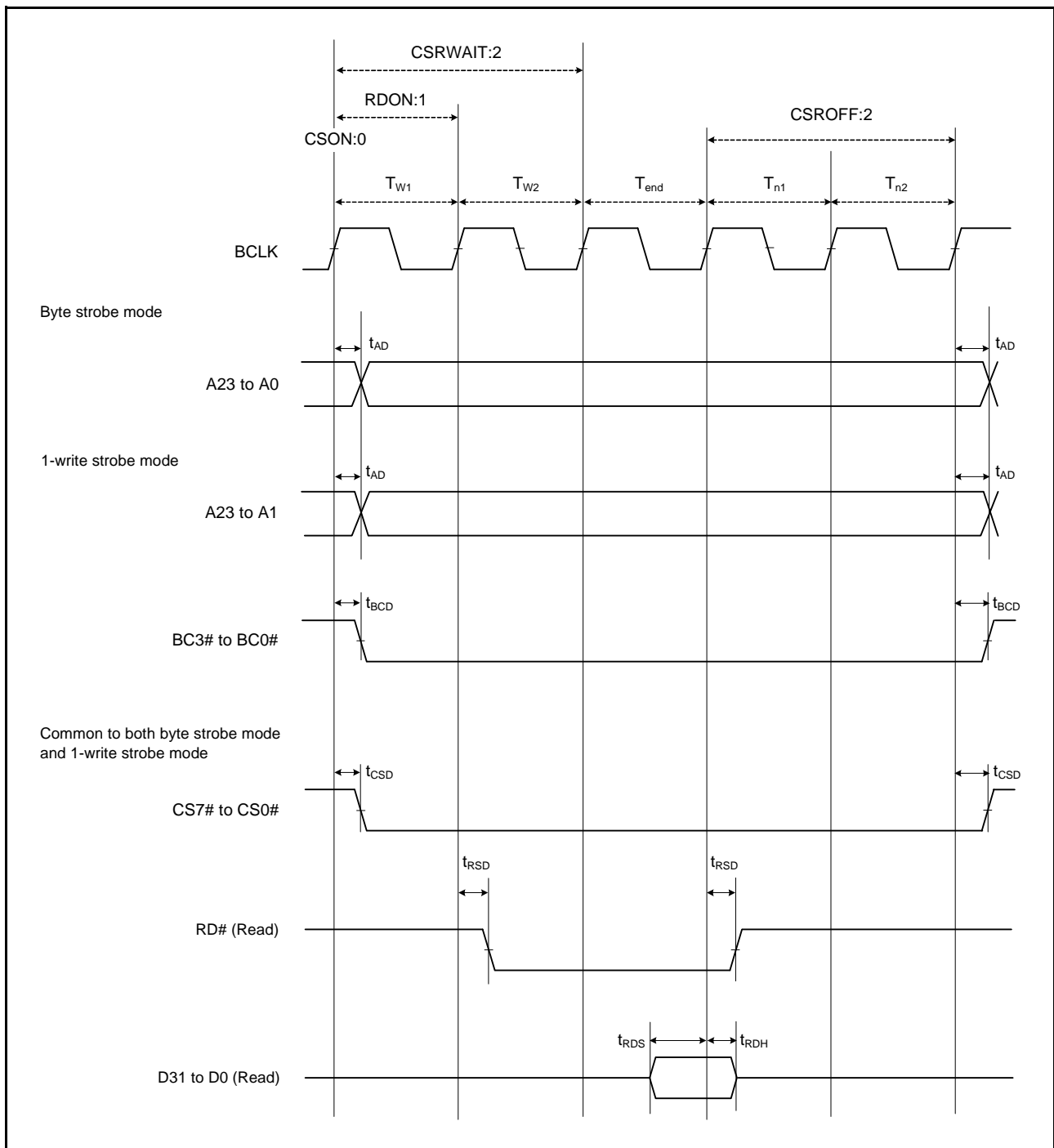

Figure 2.20 External Bus Timing/Normal Read Cycle (Bus Clock Synchronized)

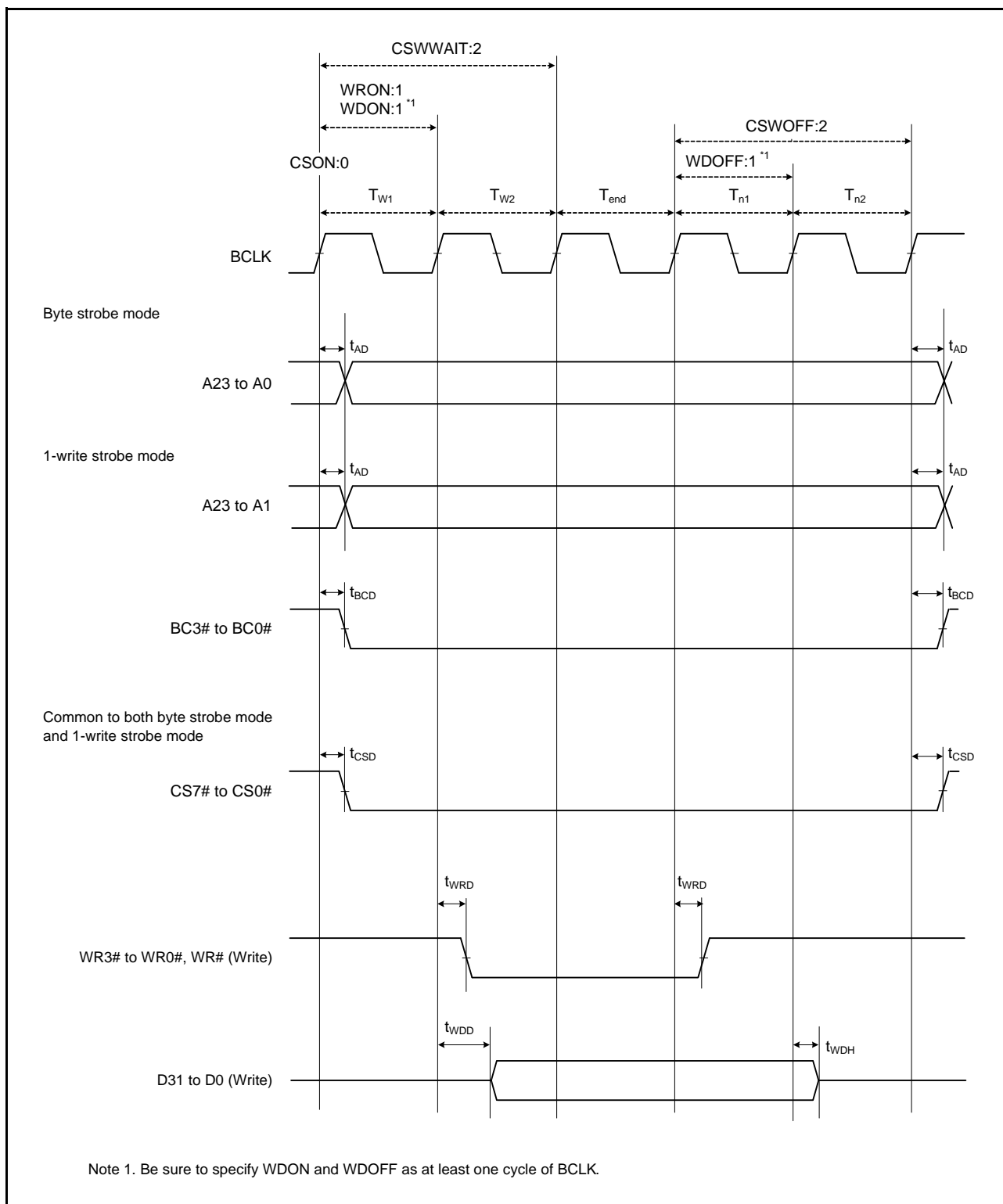

Figure 2.21 External Bus Timing/Normal Write Cycle (Bus Clock Synchronized)

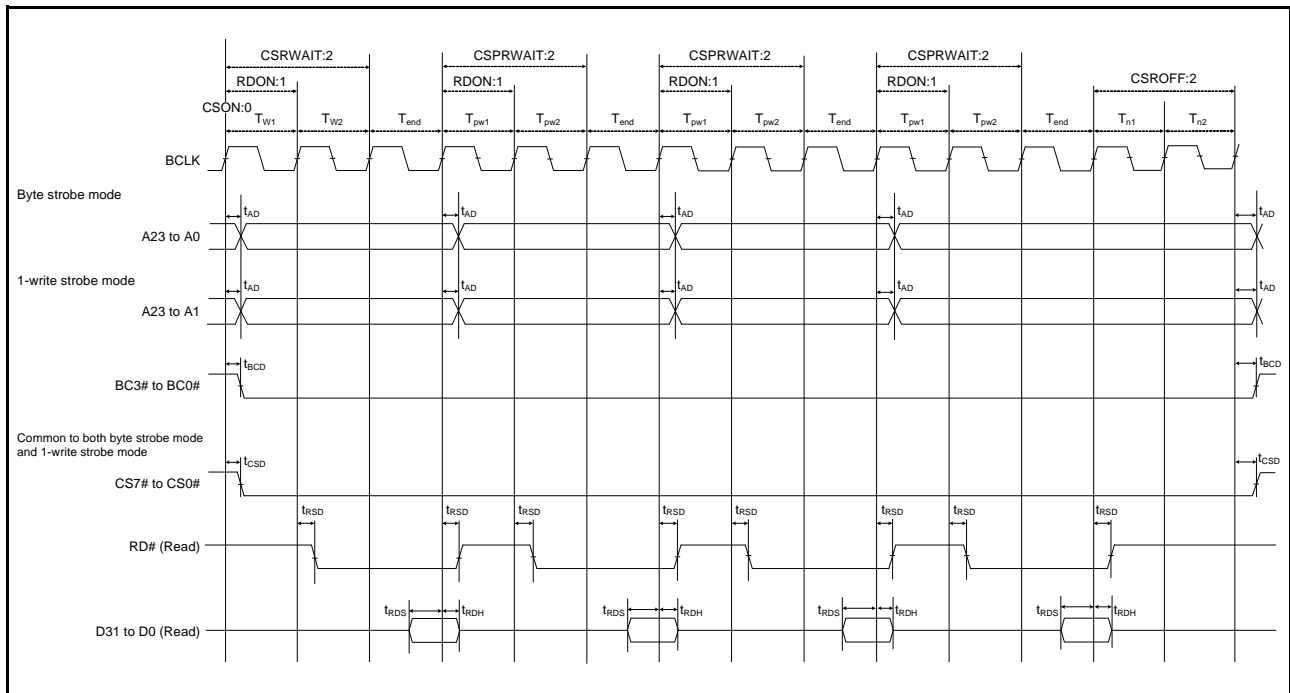

Figure 2.22 External Bus Timing/Page Read Cycle (Bus Clock Synchronized)

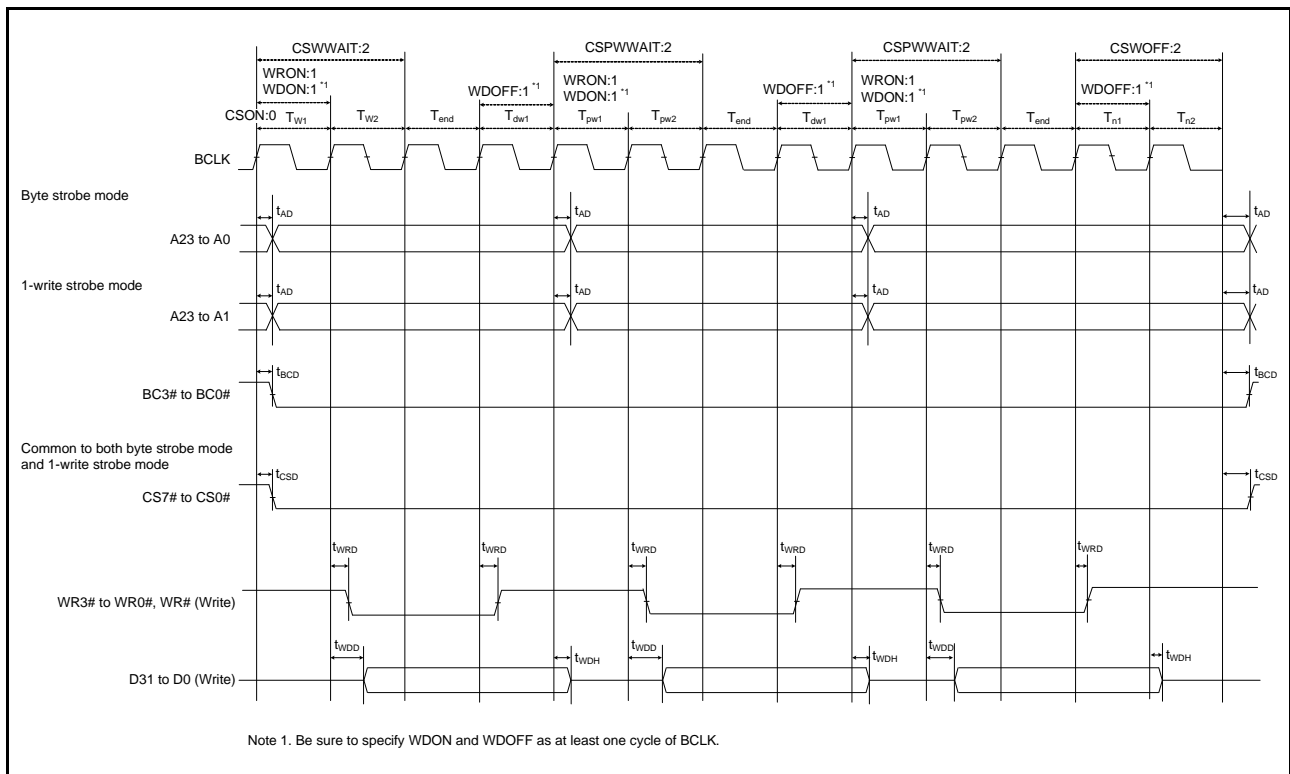

Figure 2.23 External Bus Timing/Page Write Cycle (Bus Clock Synchronized)

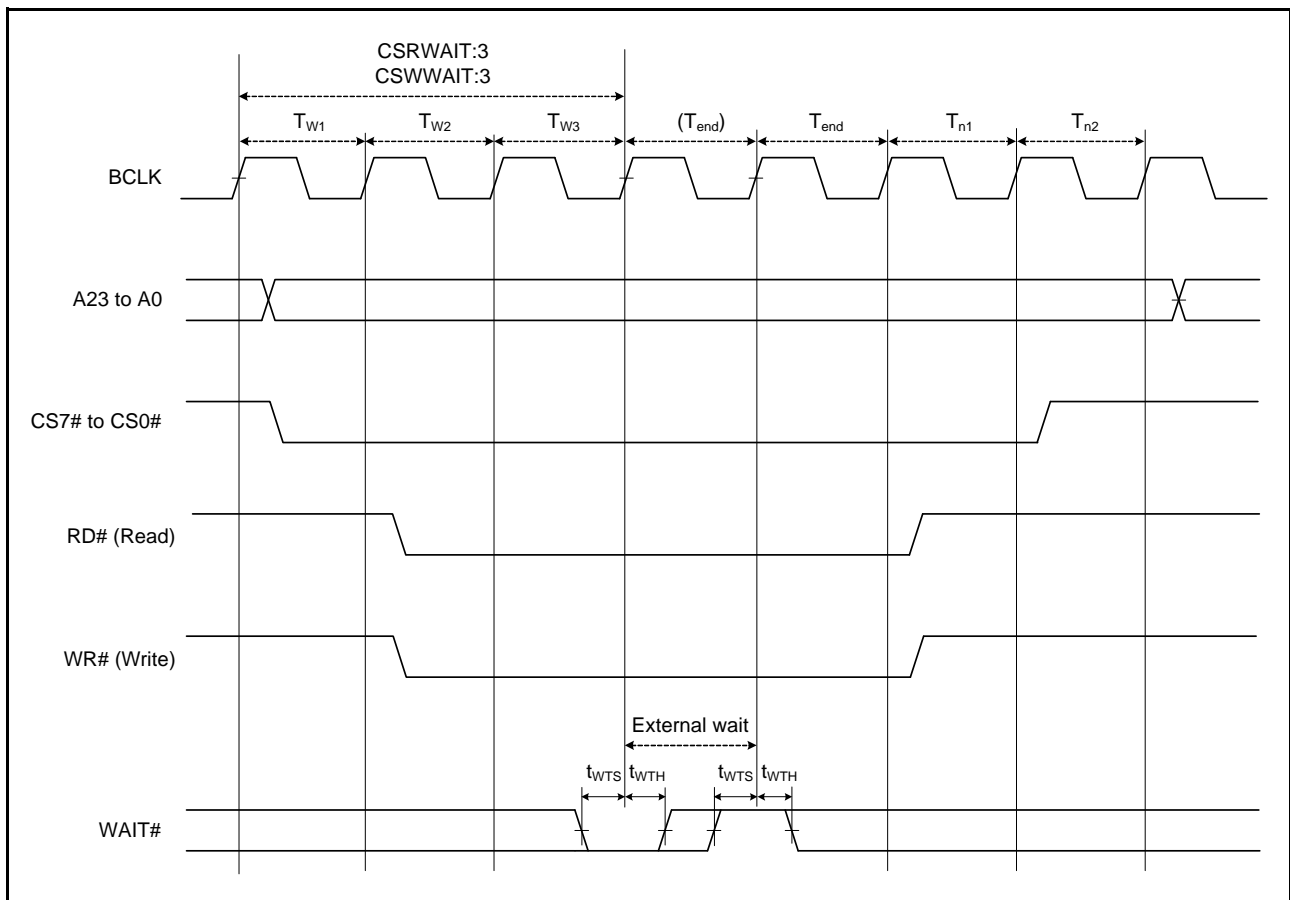

Figure 2.24 External Bus Timing/External Wait Control

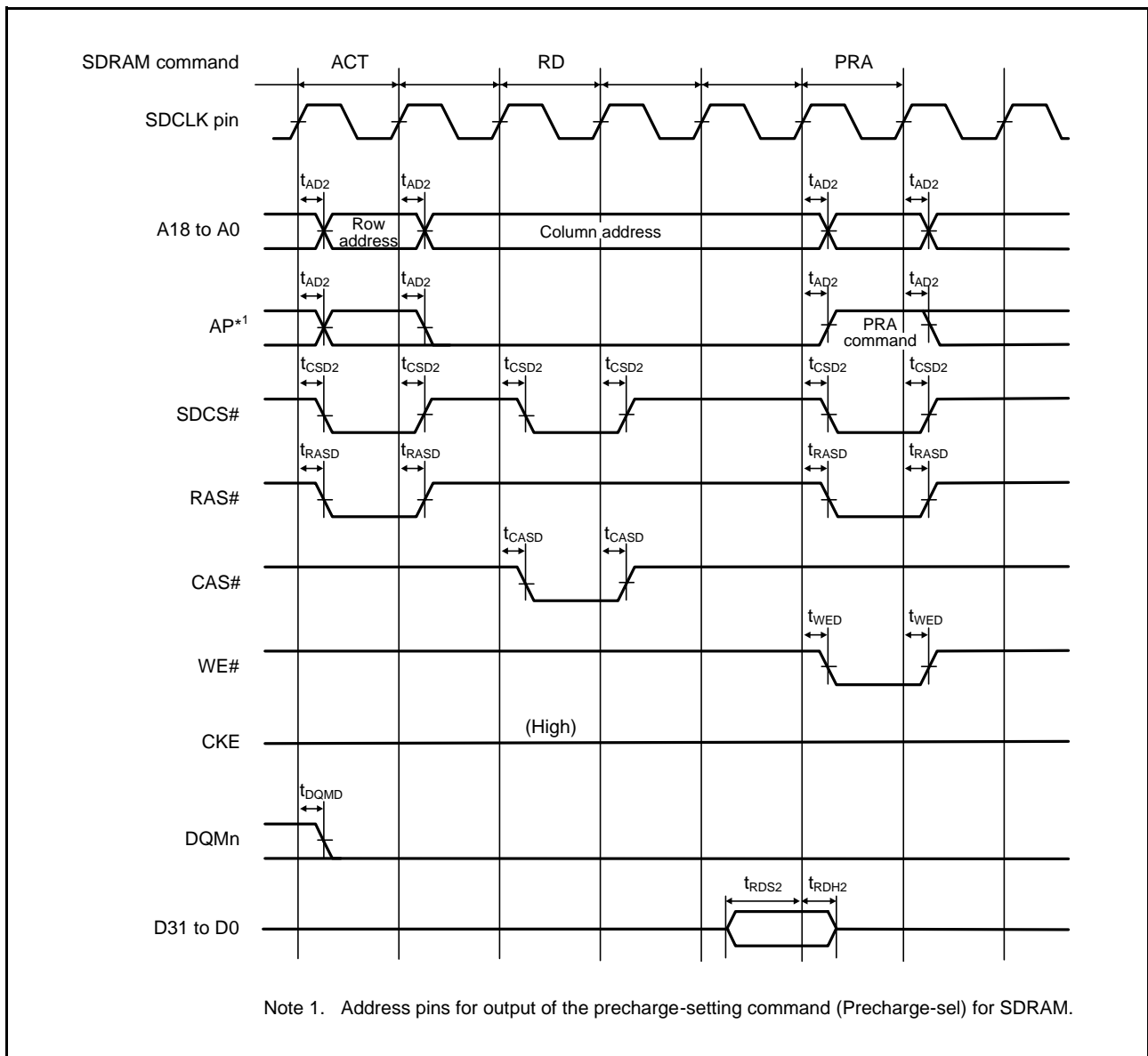

Figure 2.25 SDRAM Space Single Read Bus Timing

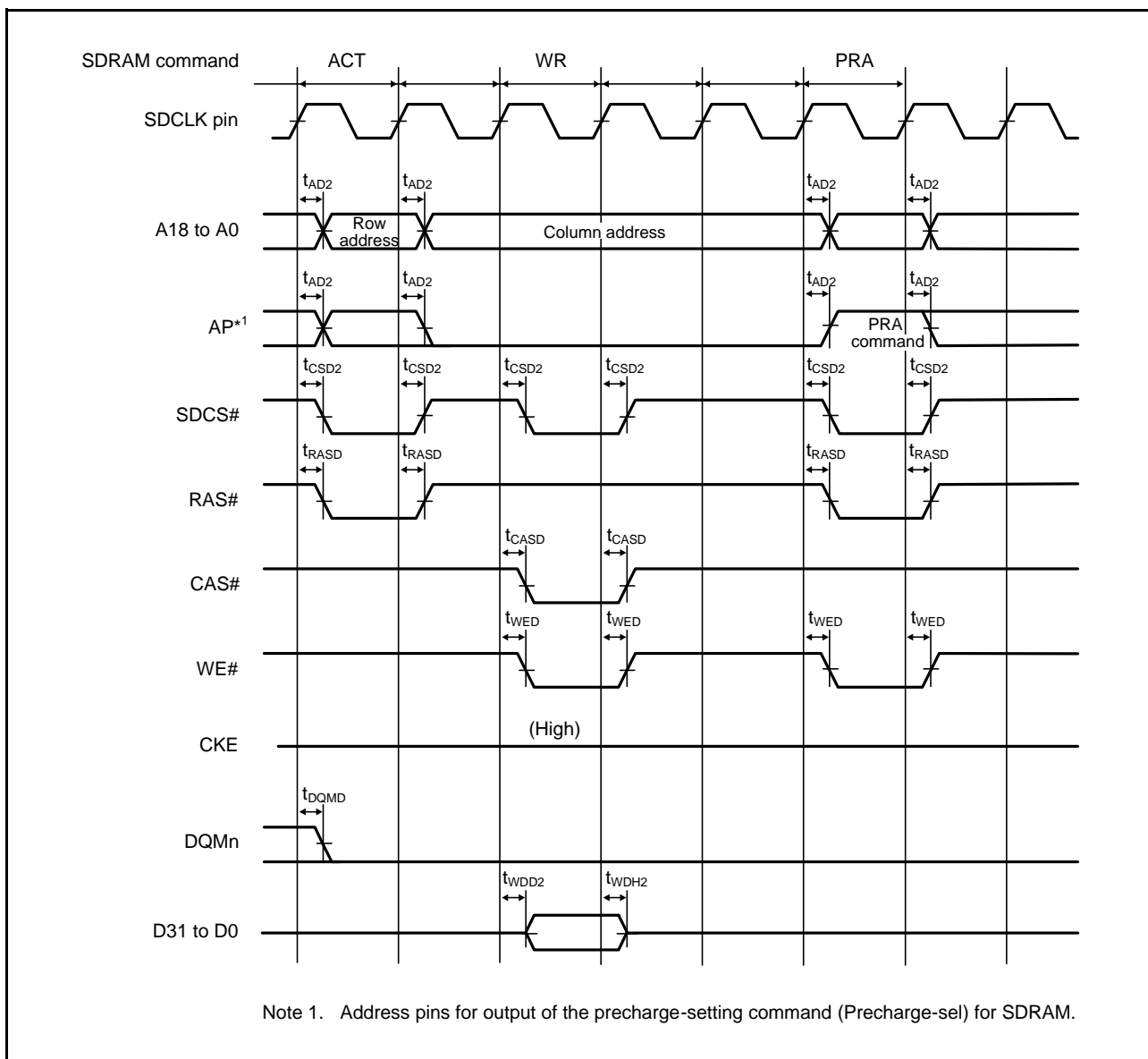

Figure 2.26 SDRAM Space Single Write Bus Timing

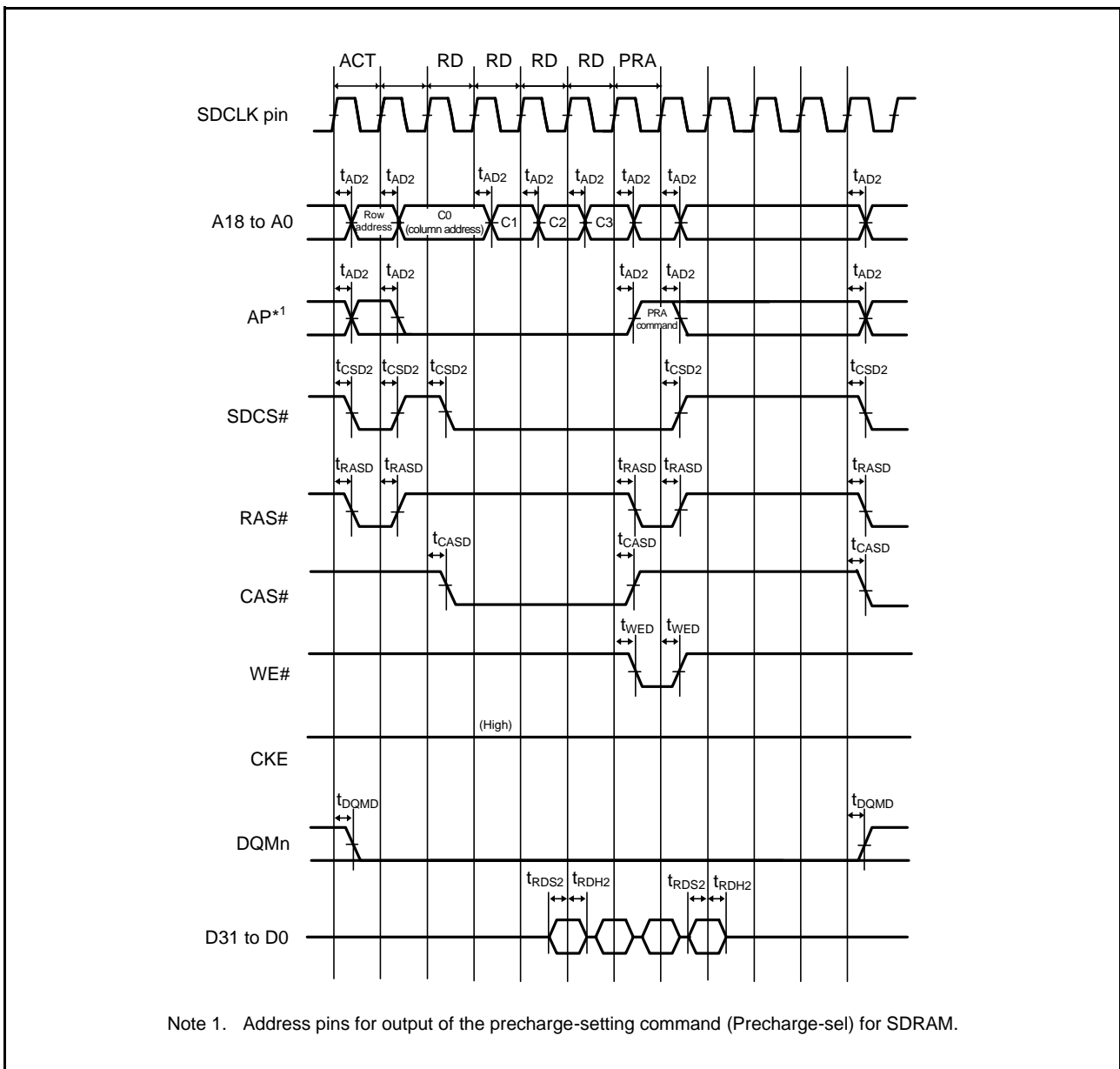

Figure 2.27 SDRAM Space Multiple Read Bus Timing

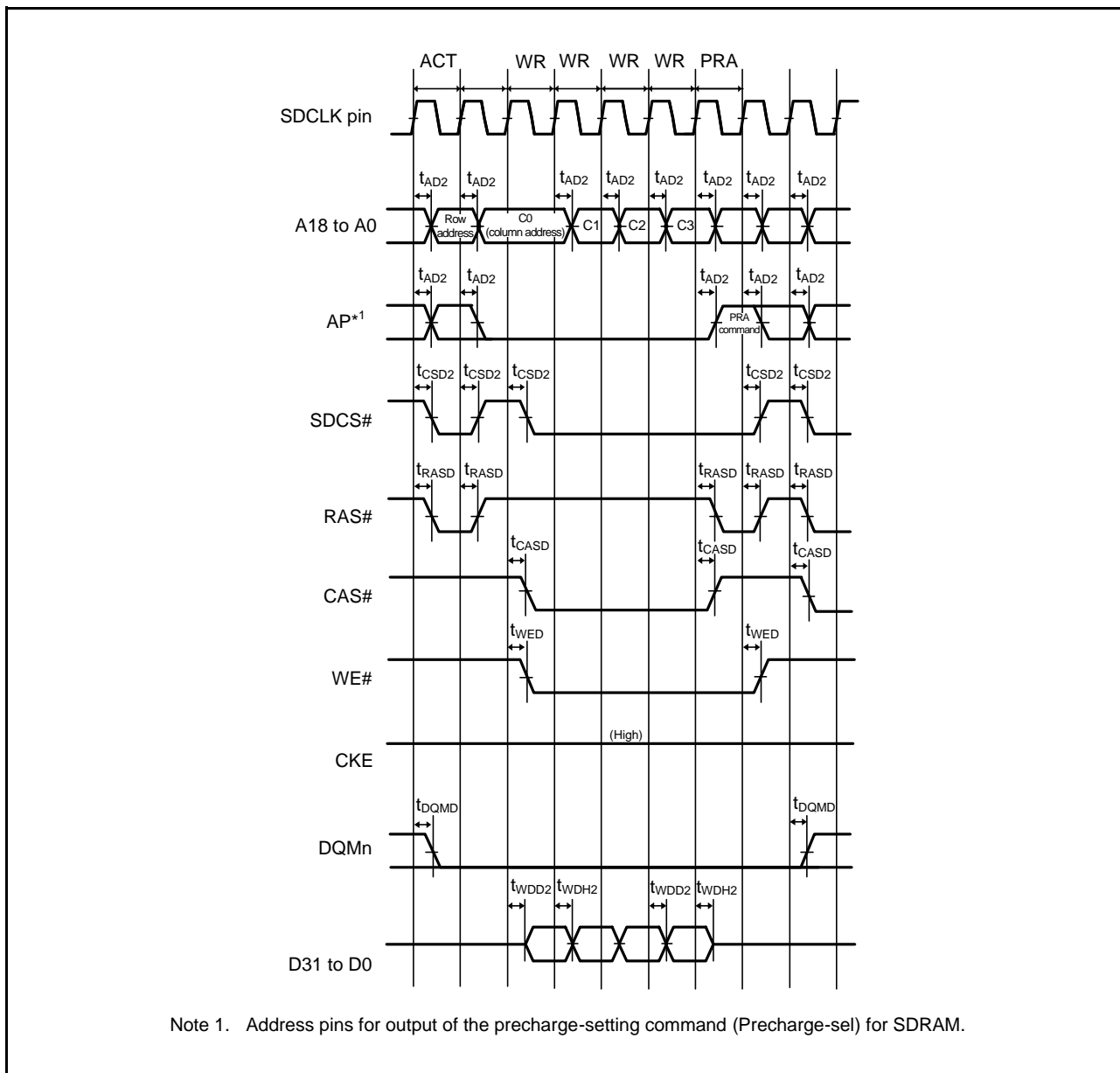

Figure 2.28 SDRAM Space Multiple Write Bus Timing

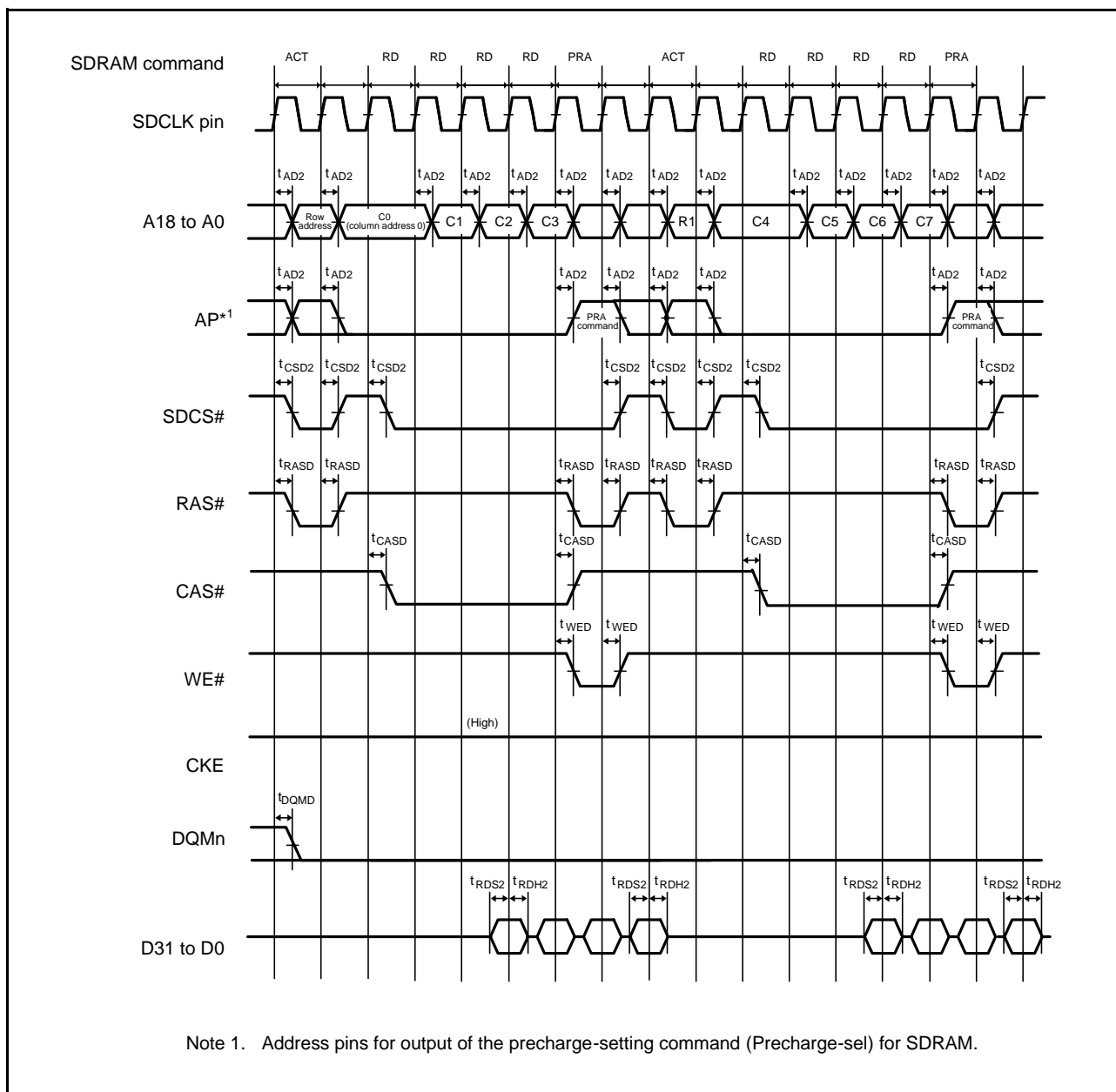

Figure 2.29 SDRAM Space Multiple Read Line Stride Bus Timing

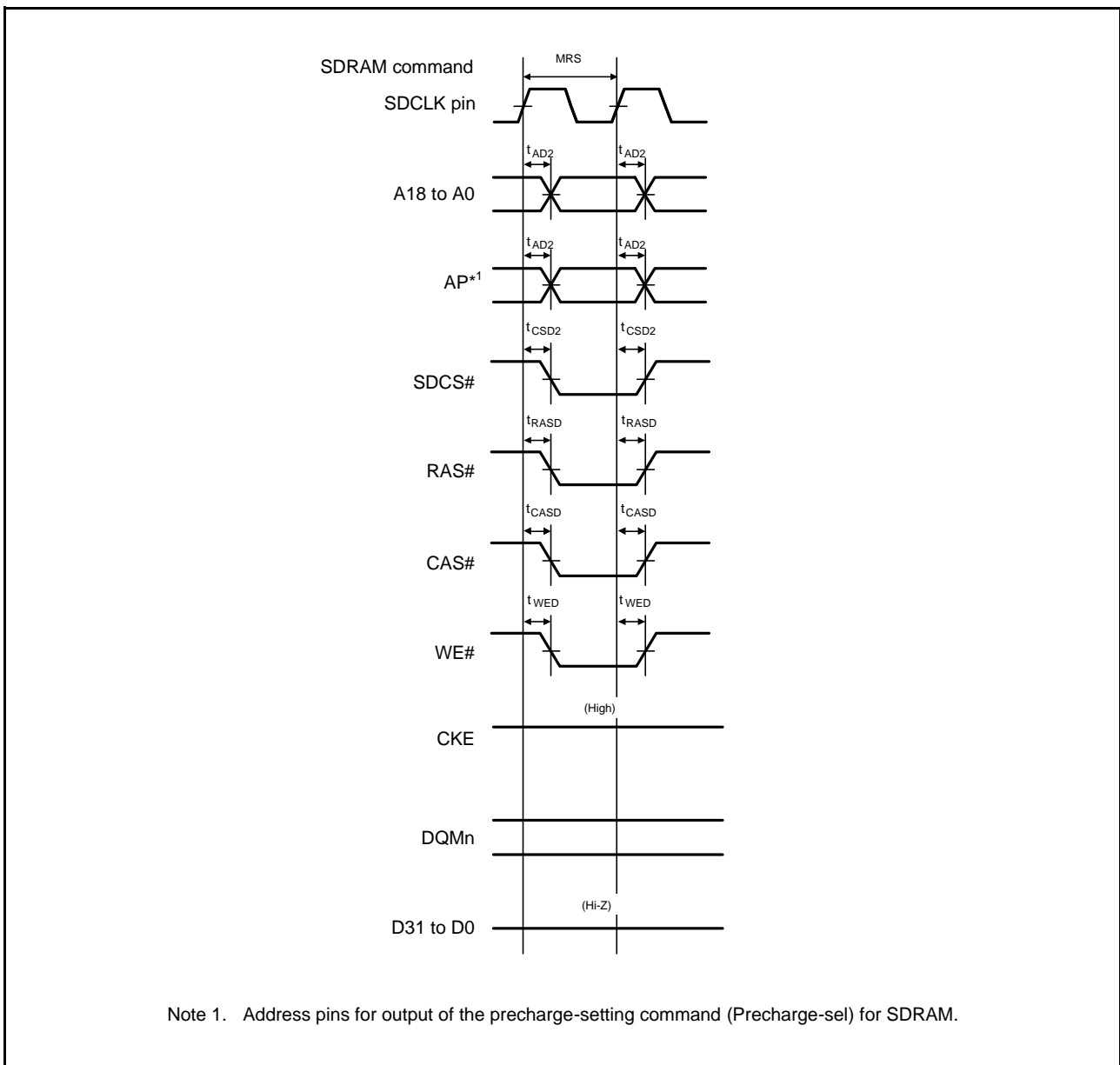

Figure 2.30 SDRAM Space Mode Register Set Bus Timing

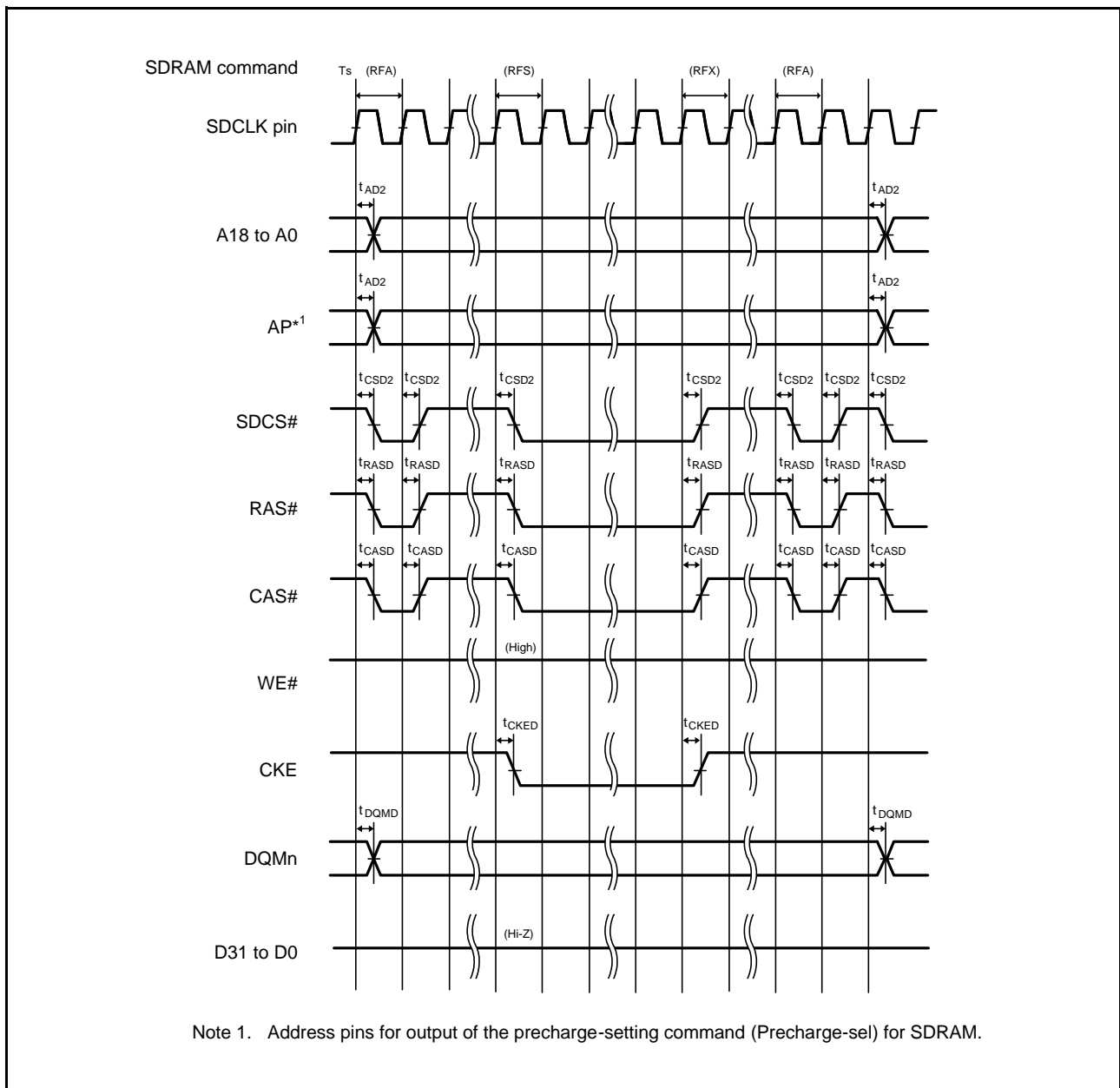

Figure 2.31 SDRAM Space Self-Refresh Bus Timing

2.4.6 EXDMAC Timing

Table 2.27 EXDMAC Timing

Conditions: $V_{CC} = AVCC0 = AVCC1 = VCC_USB = V_{BATT} = 2.7$ to 3.6 V, 2.7 V \leq $V_{REFH0} \leq AVCC0$,
 $V_{SS} = AVSS0 = AVSS1 = V_{REFL0} = V_{SS_USB} = 0$ V,
 $I_{CLK} = 8$ to 240 MHz, $P_{CLKA} = 8$ to 120 MHz, $P_{CLKB} = 8$ to 60 MHz, $BCLK = SDCLK = 8$ to 80 MHz, $T_a = T_{opr}$,
 Output load conditions: $V_{OH} = 0.5 \times V_{CC}$, $V_{OL} = 0.5 \times V_{CC}$, $C = 30$ pF,
 High-drive output is selected by the driving ability control register.

Item	Symbol	Min.	Max.	Unit	Test Conditions	
EXDMAC	EDREQ setup time	t_{EDRQS}	13	—	ns	Figure 2.32
	EDREQ hold time	t_{EDRQH}	2	—	ns	
	EDACK delay time	t_{EDACD}	—	13	ns	Figure 2.33, Figure 2.34

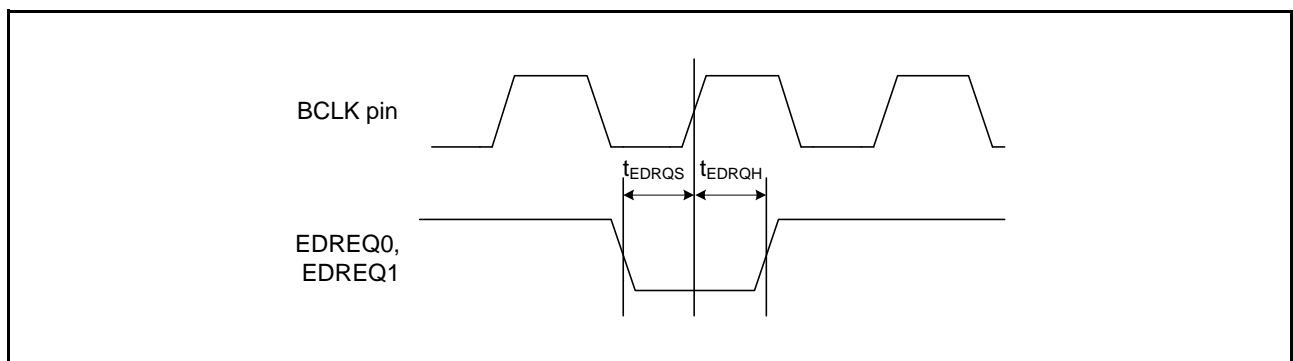

Figure 2.32 EDREQ0 and EDREQ1 Input Timing

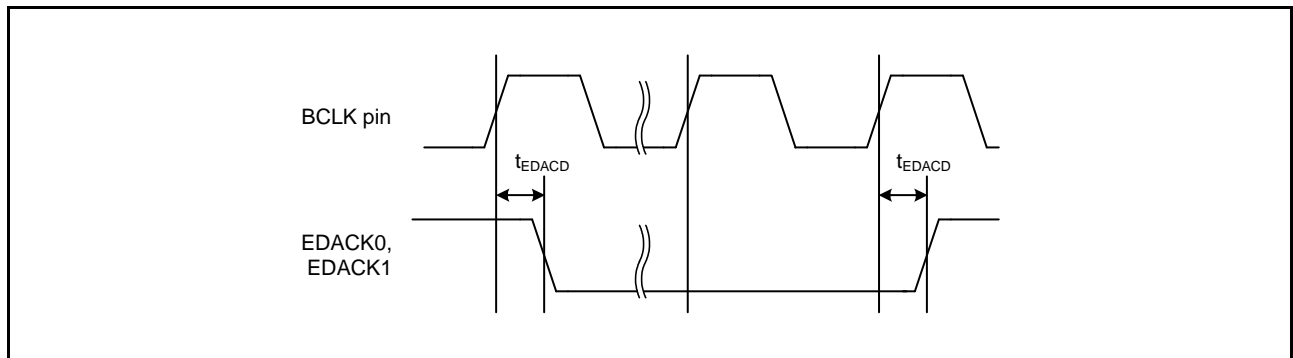

Figure 2.33 EDACK0 and EDACK1 Single-Address Transfer Timing (for a CS Area)

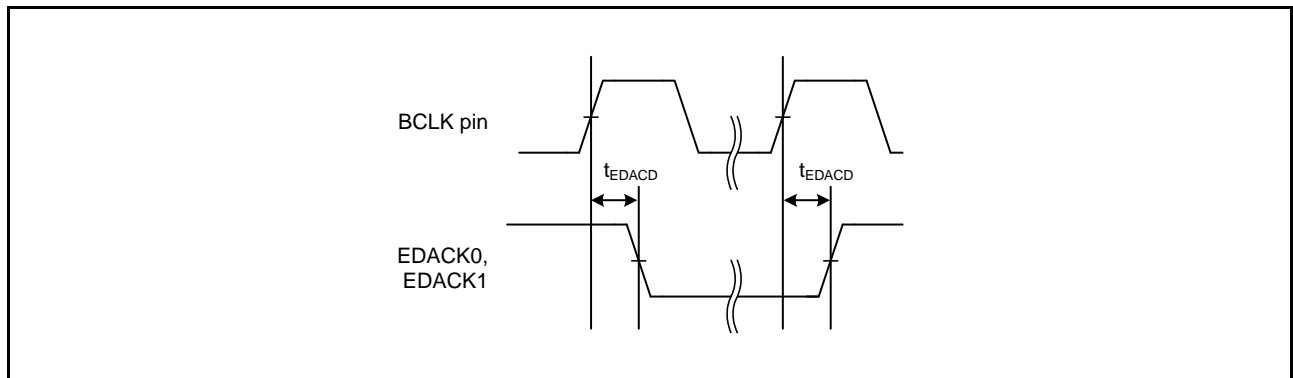

Figure 2.34 EDACK0 and EDACK1 Single-Address Transfer Timing (for SDRAM)

2.4.7 Timing of On-Chip Peripheral Modules

2.4.7.1 I/O Port

Table 2.28 I/O Port Timing

Conditions: $V_{CC} = AVCC0 = AVCC1 = VCC_USB = V_{BATT} = 2.7$ to 3.6 V, 2.7 V $\leq VREFH0 \leq AVCC0$,
 $VSS = AVSS0 = AVSS1 = VREFL0 = VSS_USB = 0$ V,
 $PCLKA = 8$ to 120 MHz, $PCLKB = 8$ to 60 MHz, $T_a = T_{opr}$,
 Output load conditions: $V_{OH} = 0.5 \times VCC$, $V_{OL} = 0.5 \times VCC$, $C = 30$ pF,
 High-drive output is selected by the driving ability control register.

Item		Symbol	Min.	Max.	Unit*1	Test Conditions
I/O ports	Input data pulse width	t_{PRW}	1.5	—	t_{PBcyc}	Figure 2.35

Note 1. t_{PBcyc} : PCLKB cycle

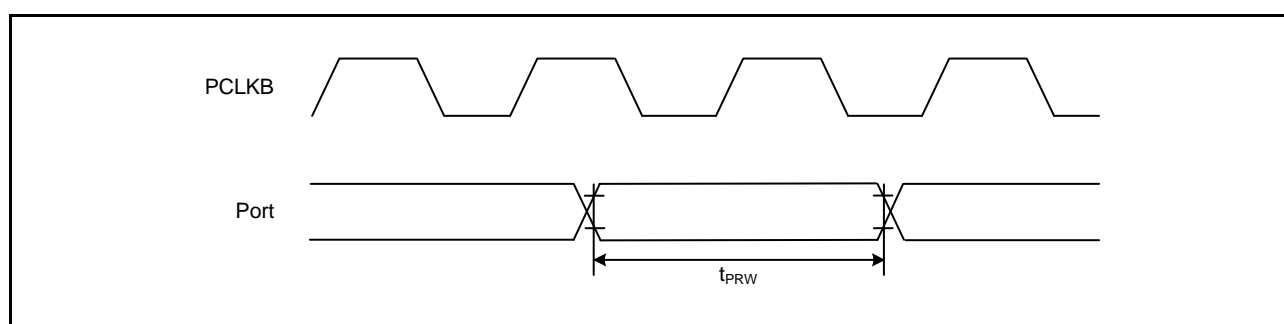

Figure 2.35 I/O Port Input Timing

2.4.7.2 TPU

Table 2.29 TPU Timing

Conditions: $V_{CC} = AVCC0 = AVCC1 = VCC_USB = V_{BATT} = 2.7$ to 3.6 V, 2.7 V \leq $V_{REFH0} \leq AVCC0$,
 $V_{SS} = AVSS0 = AVSS1 = V_{REFL0} = V_{SS_USB} = 0$ V,
 $PCLKA = 8$ to 120 MHz, $PCLKB = 8$ to 60 MHz, $T_a = T_{opr}$,
 Output load conditions: $V_{OH} = 0.5 \times V_{CC}$, $V_{OL} = 0.5 \times V_{CC}$, $C = 30$ pF,
 High-drive output is selected by the driving ability control register.

Item		Symbol	Min.	Max.	Unit*1	Test Conditions
TPU	Input capture input pulse width	Single-edge setting	1.5	—	t_{PBcyc}	Figure 2.36
		Both-edge setting	2.5	—		
TPU	Timer clock pulse width	Single-edge setting	1.5	—	t_{PBcyc}	Figure 2.37
		Both-edge setting	2.5	—		
		Phase counting mode	2.5	—		

Note 1. t_{PBcyc} : PCLKB cycle

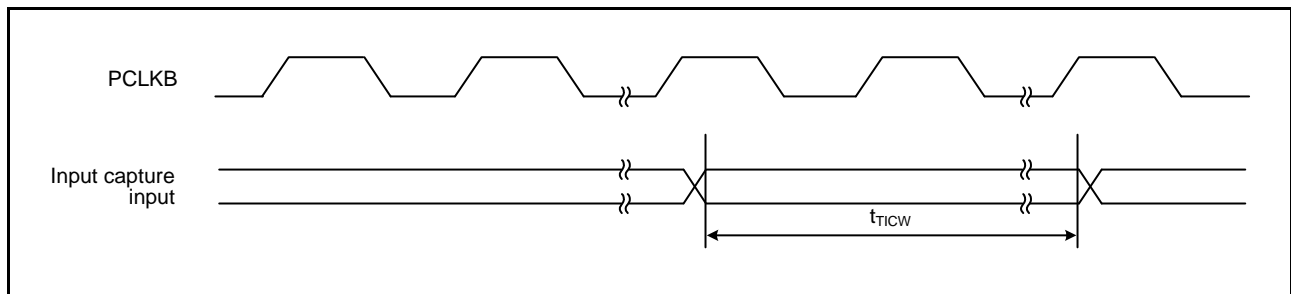

Figure 2.36 TPU Input Capture Input Timing

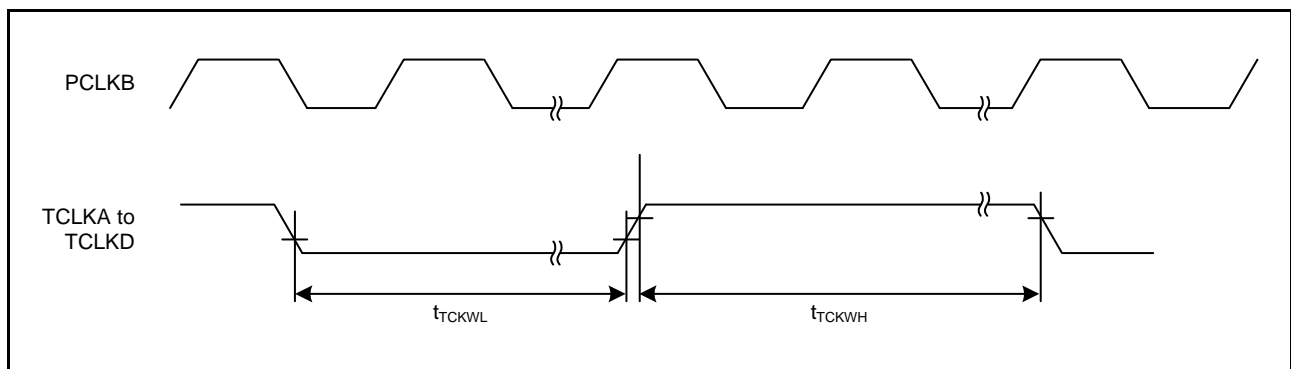

Figure 2.37 TPU Clock Input Timing

2.4.7.3 TMR

Table 2.30 TMR Timing

Conditions: $V_{CC} = AV_{CC0} = AV_{CC1} = V_{CC_USB} = V_{BATT} = 2.7$ to 3.6 V, 2.7 V \leq $V_{REFH0} \leq AV_{CC0}$,
 $V_{SS} = AV_{SS0} = AV_{SS1} = V_{REFL0} = V_{SS_USB} = 0$ V,
 $PCLKA = 8$ to 120 MHz, $PCLKB = 8$ to 60 MHz, $T_a = T_{opr}$,
 Output load conditions: $V_{OH} = 0.5 \times V_{CC}$, $V_{OL} = 0.5 \times V_{CC}$, $C = 30$ pF,
 High-drive output is selected by the driving ability control register.

Item		Symbol	Min.	Max.	Unit*1	Test Conditions
TMR	Timer clock pulse width	Single-edge setting	1.5	—	t_{PBcyc}	Figure 2.38
		Both-edge setting	2.5	—		

Note 1. t_{PBcyc} : PCLKB cycle

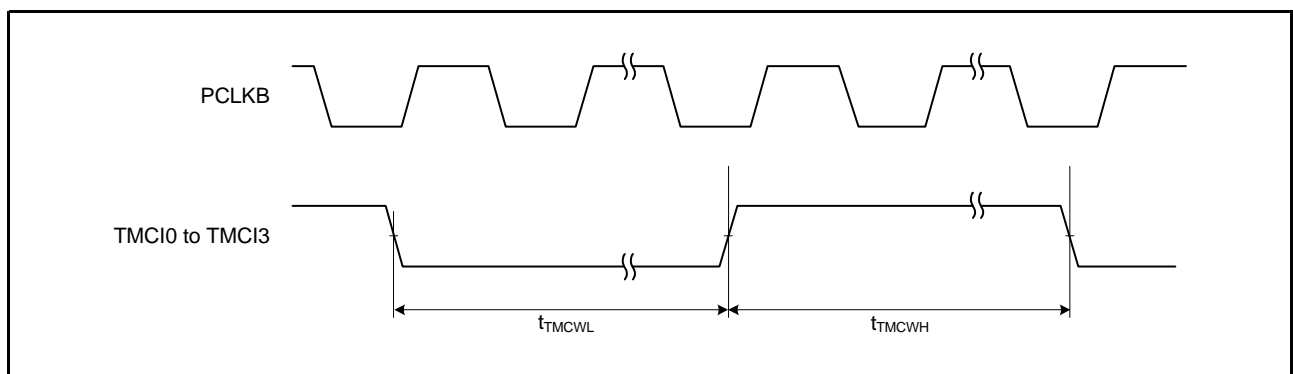

Figure 2.38 TMR Clock Input Timing

2.4.7.4 CMTW

Table 2.31 CMTW Timing

Conditions: $V_{CC} = AV_{CC0} = AV_{CC1} = V_{CC_USB} = V_{BATT} = 2.7$ to 3.6 V, 2.7 V \leq $V_{REFH0} \leq AV_{CC0}$,
 $V_{SS} = AV_{SS0} = AV_{SS1} = V_{REFL0} = V_{SS_USB} = 0$ V,
 $PCLKA = 8$ to 120 MHz, $PCLKB = 8$ to 60 MHz, $T_a = T_{opr}$,
 Output load conditions: $V_{OH} = 0.5 \times V_{CC}$, $V_{OL} = 0.5 \times V_{CC}$, $C = 30$ pF,
 High-drive output is selected by the driving ability control register.

Item		Symbol	Min.	Max.	Unit*1	Test Conditions
CMTW	Input capture input pulse width	Single-edge setting	1.5	—	t_{PBcyc}	Figure 2.39
		Both-edge setting	2.5	—		

Note 1. t_{PBcyc} : PCLKB cycle

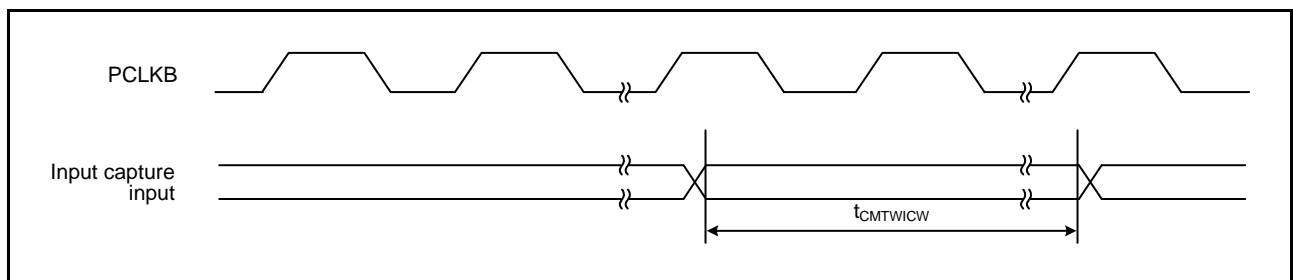

Figure 2.39 CMTW Input Capture Input Timing

2.4.7.5 MTU

Table 2.32 MTU Timing

Conditions: $V_{CC} = AVCC0 = AVCC1 = V_{CC_USB} = V_{BATT} = 2.7$ to 3.6 V, 2.7 V $\leq V_{REFH0} \leq AVCC0$,
 $V_{SS} = AVSS0 = AVSS1 = V_{REFL0} = V_{SS_USB} = 0$ V,
 $PCLKA = 8$ to 120 MHz, $PCLKB = 8$ to 60 MHz, $T_a = T_{opr}$,
 Output load conditions: $V_{OH} = 0.5 \times V_{CC}$, $V_{OL} = 0.5 \times V_{CC}$, $C = 30$ pF,
 High-drive output is selected by the driving ability control register.

Item		Symbol	Min.	Max.	Unit*1	Test Conditions	
MTU	Input capture input pulse width	Single-edge setting	1.5	—	$t_{P_{Acyc}}$	Figure 2.40	
		Both-edge setting					
	Timer clock pulse width	Single-edge setting	t_{MTCKWH} , t_{MTCKWL}	1.5	—	$t_{P_{Acyc}}$	Figure 2.41
		Both-edge setting		2.5	—		
		Phase counting mode		2.5	—		

Note 1. $t_{P_{Acyc}}$: PCLKA cycle

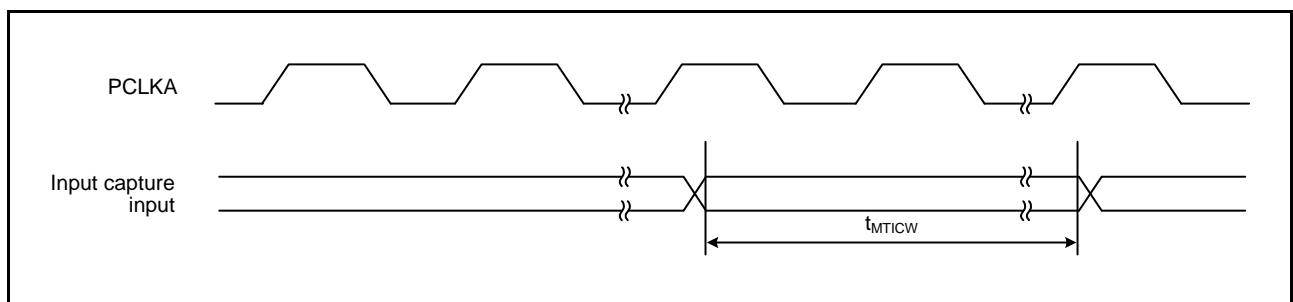

Figure 2.40 MTU Input Capture Input Timing

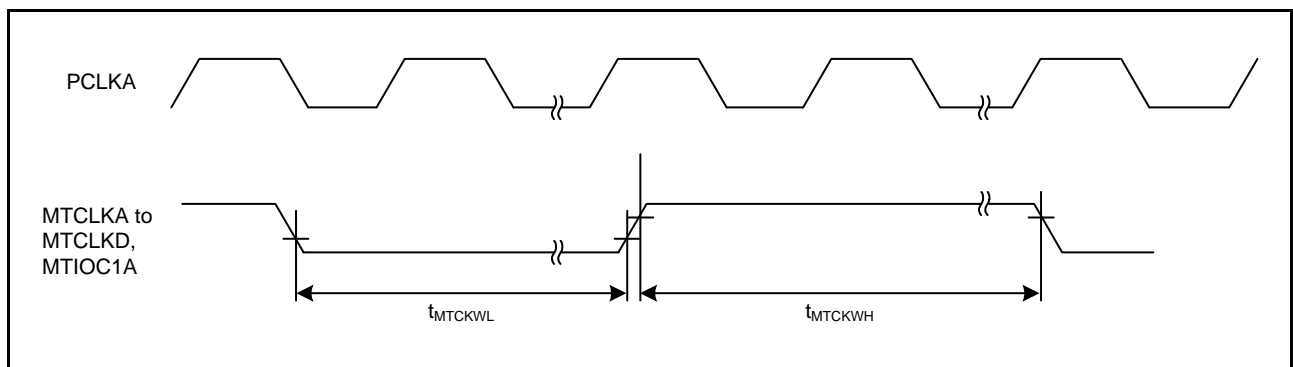

Figure 2.41 MTU Clock Input Timing

2.4.7.6 POE

Table 2.33 POE Timing

Conditions: $V_{CC} = AVCC0 = AVCC1 = VCC_USB = V_{BATT} = 2.7$ to 3.6 V, 2.7 V $\leq V_{REFH0} \leq AVCC0$,
 $V_{SS} = AVSS0 = AVSS1 = V_{REFL0} = VSS_USB = 0$ V,
 $PCLKA = 8$ to 120 MHz, $PCLKB = 8$ to 60 MHz, $T_a = T_{opr}$,
 Output load conditions: $V_{OH} = 0.5 \times V_{CC}$, $V_{OL} = 0.5 \times V_{CC}$, $C = 30$ pF,
 High-drive output is selected by the driving ability control register.

Item		Symbol	Min.	Typ.	Max.	Unit*1	Test Conditions	
POE	POEn# input pulse width (n = 0, 4, 8, 10, 11)	t _{POEW}	1.5	—	—	t _{PBcyc}	Figure 2.42	
	Output disable time	Transition of the POEn# signal level	t _{POEDI}	—	—	5 PCLKB + 0.24	μs	Figure 2.43 When detecting falling edges (ICSRm.POEnM[3:0] = 0000 (m = 1 to 5; n = 0, 4, 8, 10, 11))
		Simultaneous conduction of output pins	t _{POEDO}	—	—	3 PCLKB + 0.2	μs	Figure 2.44
		Register setting	t _{POEDS}	—	—	1 PCLKB + 0.2	μs	Figure 2.45 Time for access to the register is not included.
		Oscillation stop detection	t _{POEDOS}	—	—	21	μs	Figure 2.46

Note 1. t_{PBcyc}: PCLKB cycle

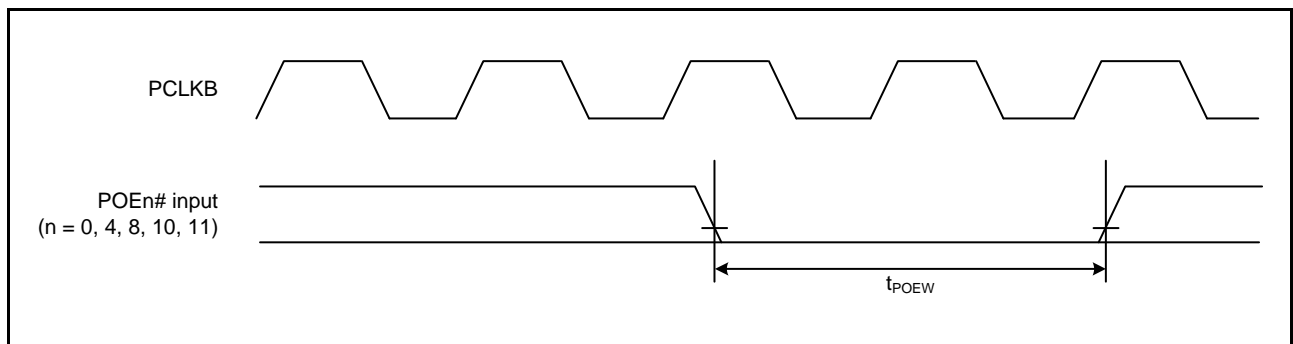

Figure 2.42 POE# Input Timing

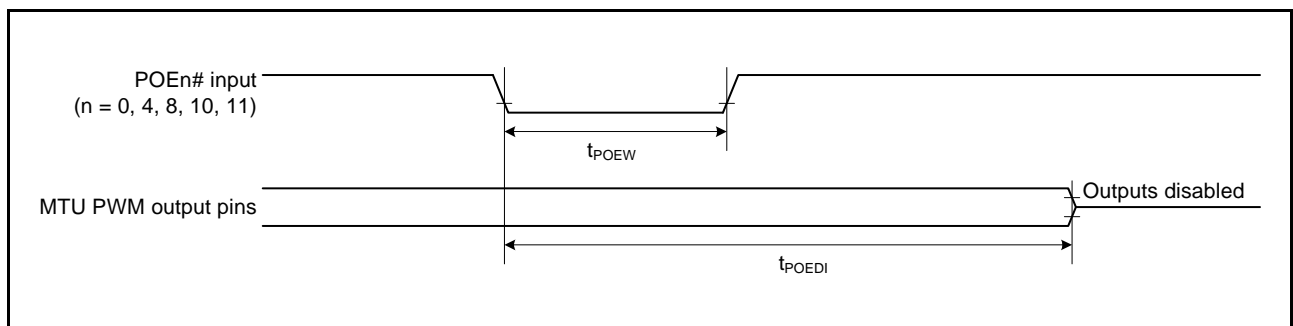

Figure 2.43 Output Disable Time for POE in Response to Transition of the POEn# Signal Level

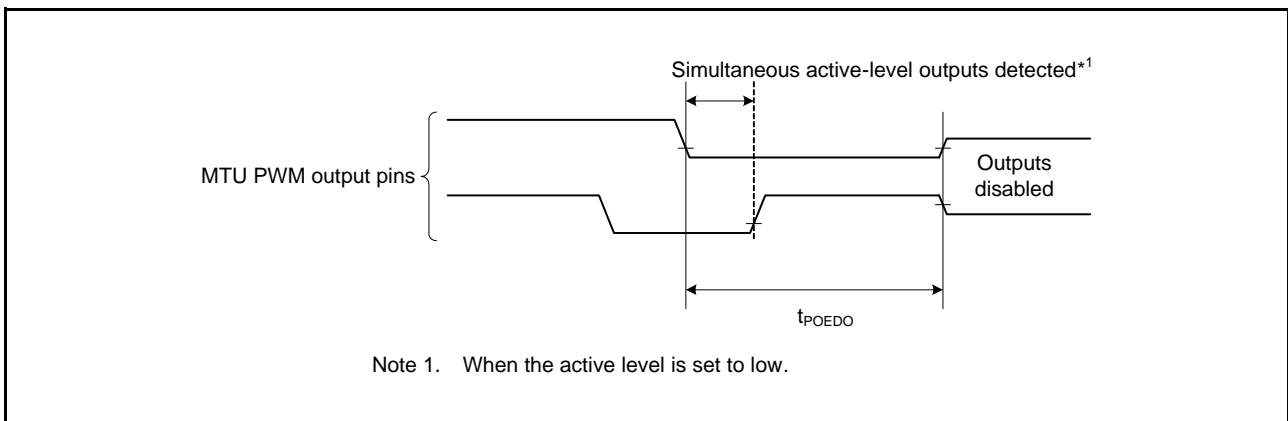

Figure 2.44 Output Disable Time for POE in Response to the Simultaneous Conduction of Output Pins

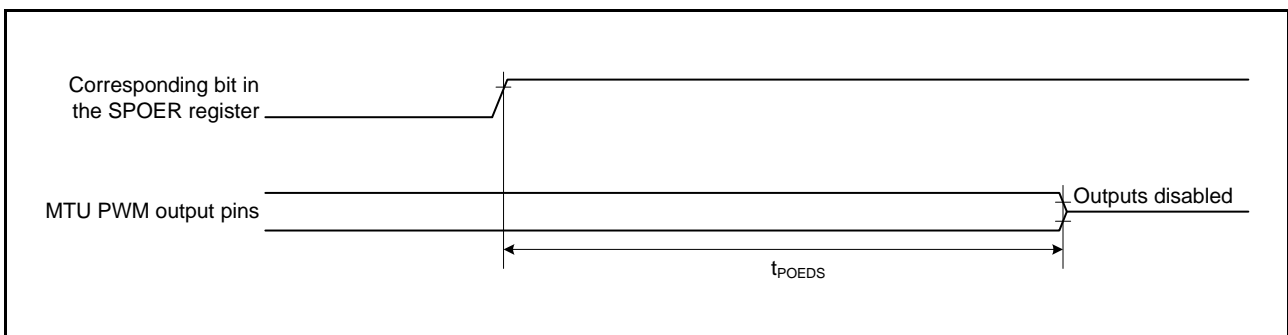

Figure 2.45 Output Disable Time for POE in Response to the Register Setting

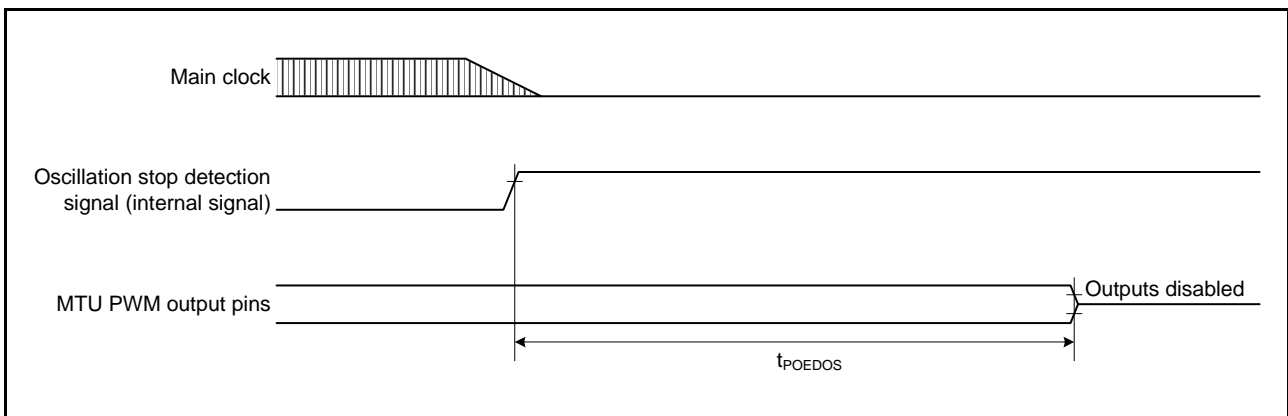

Figure 2.46 Output Disable Time for POE in Response to the Oscillation Stop Detection

2.4.7.7 POEG

Table 2.34 POEG Timing

Conditions: $V_{CC} = AV_{CC0} = AV_{CC1} = V_{CC_USB} = V_{BATT} = 2.7$ to 3.6 V, 2.7 V $\leq V_{REFH0} \leq AV_{CC0}$,
 $V_{SS} = AV_{SS0} = AV_{SS1} = V_{REFL0} = V_{SS_USB} = 0$ V,
 $PCLKA = 8$ to 120 MHz, $PCLKB = 8$ to 60 MHz, $T_a = T_{opr}$,
 Output load conditions: $V_{OH} = 0.5 \times V_{CC}$, $V_{OL} = 0.5 \times V_{CC}$, $C = 30$ pF,
 High-drive output is selected by the driving ability control register.

Item		Symbol	Min.	Typ.	Max.	Unit*1	Test Conditions	
POEG	GTETRn input pulse width (n = A to D)	t_{POEGW}	1.5	—	—	t_{PBcyc}	Figure 2.47	
	Output disable time	Input level detection of the GTETRn pin (via flag)	t_{POEGDI}	—	—	3 PCLKB + 0.34	μ s	Figure 2.48 When the digital noise filter is not in use (POEGn.NFEN = 0 (n = A to D))
		Detection of the output stopping signal from GPTW (deadtime error, simultaneous high output, or simultaneous low output)	t_{POEGDE}	—	—	0.5	μ s	Figure 2.49
		Register setting	t_{POEGDS}	—	—	1 PCLKB + 0.3	μ s	Figure 2.50 Time for access to the register is not included.
		Oscillation stop detection	$t_{POEGDOS}$	—	—	21	μ s	Figure 2.51

Note 1. t_{PBcyc} : PCLKB cycle

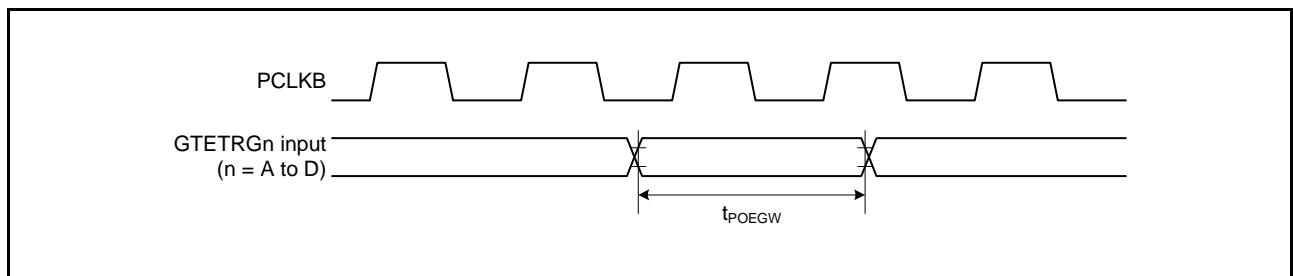

Figure 2.47 POEG Input Timing

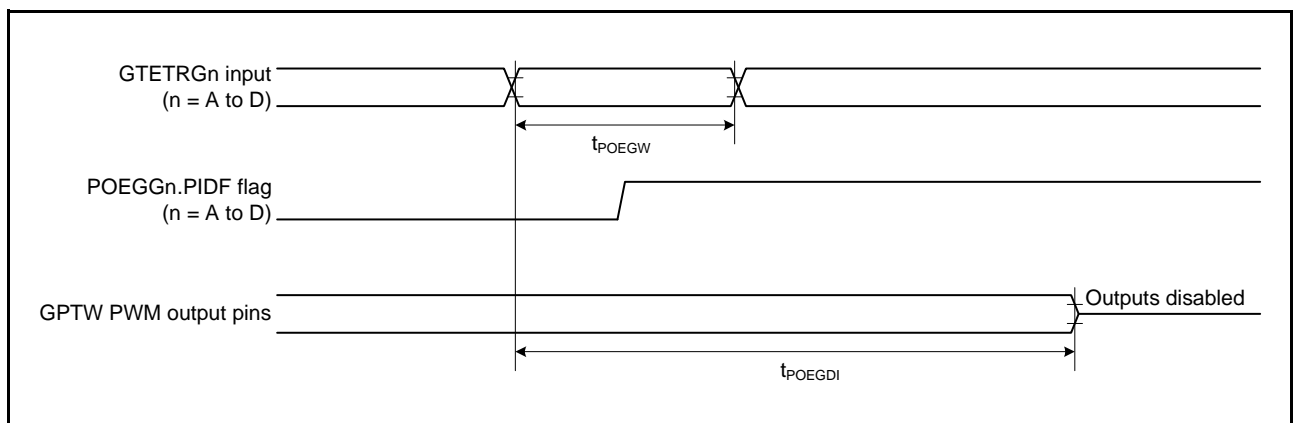

Figure 2.48 Output Disable Time for POEG via Detection Flag in Response to the Input Level Detection of the GTETRn pin

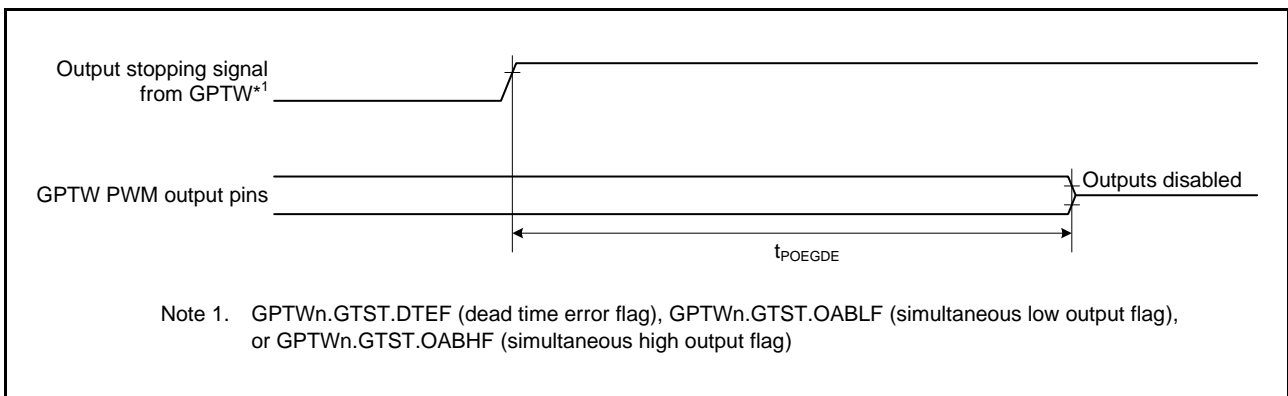

Figure 2.49 Output Disable Time for POEG in Response to Detection of the Output Stopping Signal from GPTW

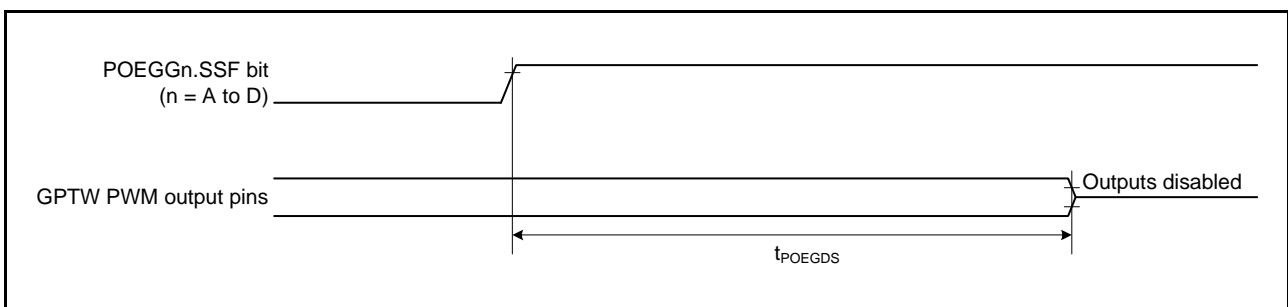

Figure 2.50 Output Disable Time for POEG in Response to the Register Setting

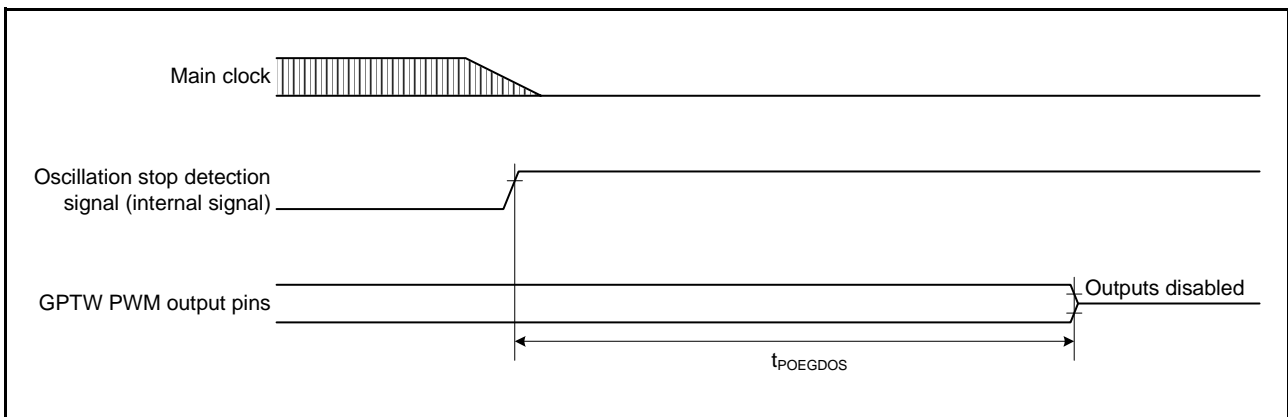

Figure 2.51 Output Disable Time of POEG in Response to the Oscillation Stop Detection

2.4.7.8 GPTW

Table 2.35 GPTW Timing

Conditions: $V_{CC} = AVCC0 = AVCC1 = VCC_USB = V_{BATT} = 2.7$ to 3.6 V, 2.7 V $\leq V_{REFH0} \leq AVCC0$,
 $V_{SS} = AVSS0 = AVSS1 = V_{REFL0} = VSS_USB = 0$ V,
 $PCLKA = 8$ to 120 MHz, $PCLKB = 8$ to 60 MHz, $T_a = T_{opr}$,
 Output load conditions: $V_{OH} = 0.5 \times V_{CC}$, $V_{OL} = 0.5 \times V_{CC}$, $C = 30$ pF,
 High-drive output is selected by the driving ability control register.

Item		Symbol	Min.	Max.	Unit*1, *2	Test Conditions
GPTW	Input capture input pulse width	Single-edge setting	1.5	—	$t_{P_{Acyc}}$	Figure 2.52
		Both-edge setting				
GPTW	External trigger input pulse width	Single-edge setting	1.5	—	$t_{P_{Bcyc}}$	Figure 2.53
		Both-edge setting				

Note 1. $t_{P_{Acyc}}$: PCLKA cycle
 Note 2. $t_{P_{Bcyc}}$: PCLKB cycle

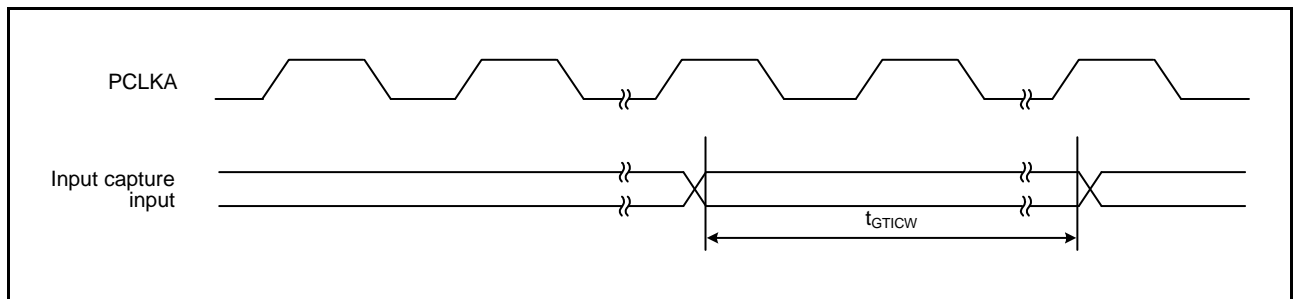

Figure 2.52 GPTW Input Capture Input Timing

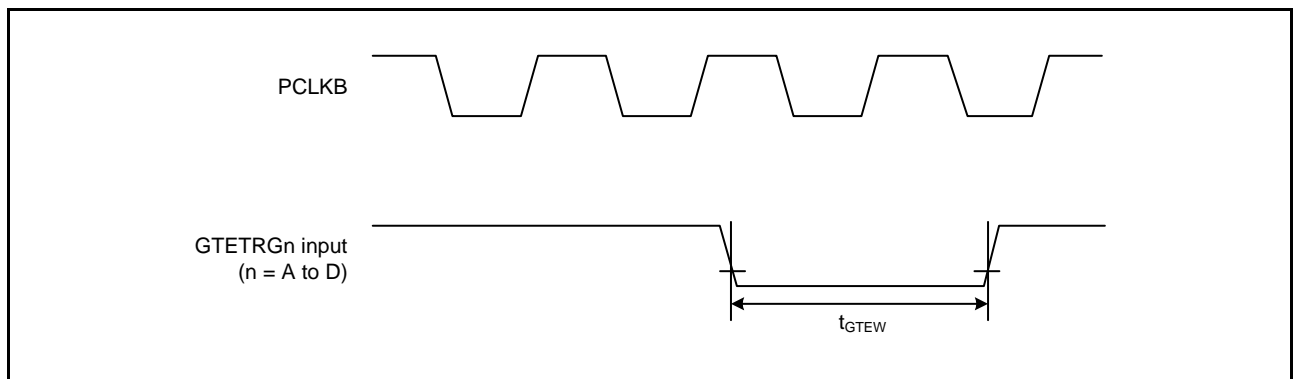

Figure 2.53 GPTW External Trigger Input Timing

2.4.7.9 SCI

Table 2.36 SCI Timing

Conditions: $V_{CC} = AVCC0 = AVCC1 = V_{CC_USB} = V_{BATT} = 2.7$ to 3.6 V, 2.7 V $\leq V_{REFH0} \leq AVCC0$,
 $V_{SS} = AVSS0 = AVSS1 = V_{REFL0} = V_{SS_USB} = 0$ V,
 $PCLKA = 8$ to 120 MHz, $PCLKB = 8$ to 60 MHz, $T_a = T_{opr}$,
 Output load conditions: $V_{OH} = 0.5 \times V_{CC}$, $V_{OL} = 0.5 \times V_{CC}$, $C = 30$ pF,
 High-drive output is selected by the driving ability control register.

Item		Symbol	Min.	Max.	Unit ^{*1}	Test Conditions		
SCIh, SCIj	Input clock cycle	Asynchronous	t _{Scyc}	4	—	t _{PBcyc}	Figure 2.54	
		Clock synchronous		6	—			
	Input clock pulse width		t _{SCKW}	0.4	0.6	t _{Scyc}		
	Input clock rise time		t _{SCKr}	—	5	ns		
	Input clock fall time		t _{SCKf}	—	5	ns		
	Output clock cycle	Asynchronous ^{*2}	t _{Scyc}	8	—	t _{PBcyc}		
		Clock synchronous		4	—			
	Output clock pulse width		t _{SCKW}	0.4	0.6	t _{Scyc}		
	Output clock rise time		t _{SCKr}	—	5	ns		
	Output clock fall time		t _{SCKf}	—	5	ns		
	Transmit data delay time	Clock synchronous	t _{TXD}	—	28	ns		Figure 2.55
	Receive data setup time	Clock synchronous	t _{RXS}	15	—	ns		
Receive data hold time	Clock synchronous	t _{RXH}	5	—	ns			
SCli	Input clock cycle	Asynchronous	t _{Scyc}	4	—	t _{PAcyc}	Figure 2.54	
		Clock synchronous		12	—			
	Input clock pulse width		t _{SCKW}	0.4	0.6	t _{Scyc}		
	Input clock rise time		t _{SCKr}	—	5	ns		
	Input clock fall time		t _{SCKf}	—	5	ns		
	Output clock cycle	Asynchronous ^{*2}	t _{Scyc}	8	—	t _{PAcyc}		
		Clock synchronous		8	—			
	Output clock pulse width		t _{SCKW}	0.4	0.6	t _{Scyc}		
	Output clock rise time		t _{SCKr}	—	5	ns		
	Output clock fall time		t _{SCKf}	—	5	ns		
	Transmit data delay time	Master	t _{TXD}	—	15	ns		Figure 2.55
		Slave		—	28			
Receive data setup time	Clock synchronous	t _{RXS}	20	—	ns			
Receive data hold time	Clock synchronous	t _{RXH}	5	—	ns			

Note 1. t_{PBcyc}: PCLKB cycle; t_{PAcyc}: PCLKA cycle

Note 2. When the SEMR.ABCS and SEMR.BGDM bits are set to 1

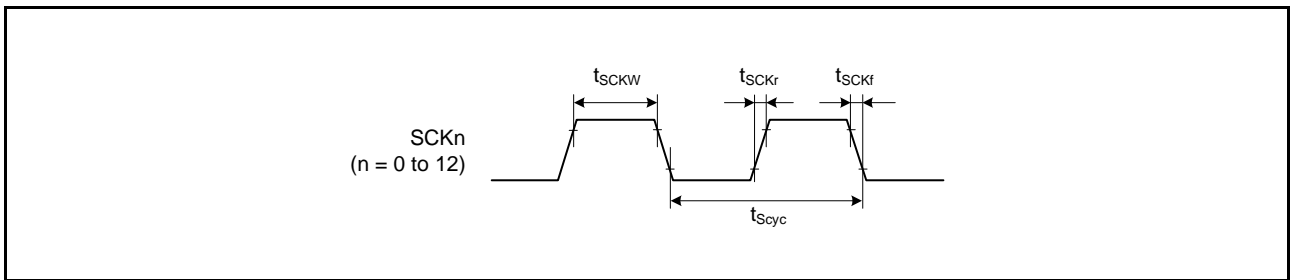

Figure 2.54 SCK Clock Input Timing

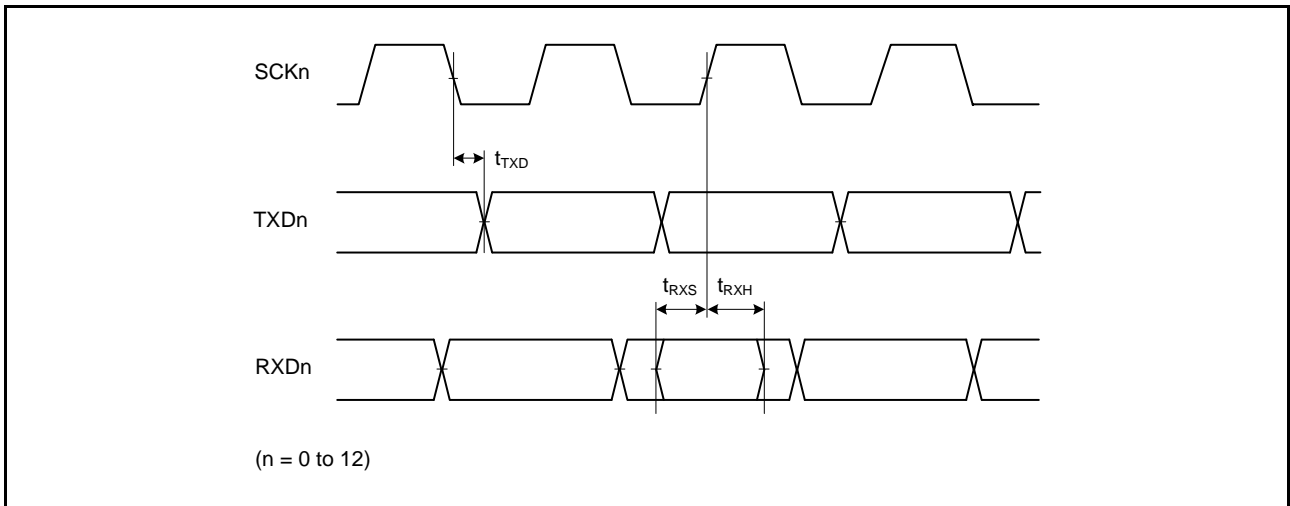

Figure 2.55 SCI Input/Output Timing: Clock Synchronous Mode

Table 2.37 Simple IIC Timing

Conditions: $V_{CC} = AV_{CC0} = AV_{CC1} = V_{CC_USB} = V_{BATT} = 2.7$ to 3.6 V, 2.7 V $\leq V_{REFH0} \leq AV_{CC0}$,
 $V_{SS} = AV_{SS0} = AV_{SS1} = V_{REFL0} = V_{SS_USB} = 0$ V,
 $PCLKA = 8$ to 120 MHz, $PCLKB = 8$ to 60 MHz, $T_a = T_{opr}$,
 High-drive output is selected by the driving ability control register.

Item		Symbol	Min.	Max.	Unit	Test Conditions
Simple IIC (Standard-mode)	SSDA input rise time	t_{Sr}	—	1000	ns	Figure 2.56
	SSDA input fall time	t_{Sf}	—	300	ns	
	SSDA input spike pulse removal time	t_{SP}	0	$4 \times t_{PBcyc}$	ns	
	Data input setup time	t_{SDAS}	250	—	ns	
	Data input hold time	t_{SDAH}	0	—	ns	
	SSCL, SSDA capacitive load	C_b^{*1}	—	400	pF	
Simple IIC (Fast-mode)	SSCL, SSDA input rise time	t_{Sr}	—	300	ns	
	SSCL, SSDA input fall time	t_{Sf}	—	300	ns	
	SSCL, SSDA input spike pulse removal time	t_{SP}	0	$4 \times t_{PBcyc}$	ns	
	Data input setup time	t_{SDAS}	100	—	ns	
	Data input hold time	t_{SDAH}	0	—	ns	
	SSCL, SSDA capacitive load	C_b^{*1}	—	400	pF	

Note: t_{PBcyc} : PCLKB cycle

Note 1. C_b is the total capacitance of the bus lines.

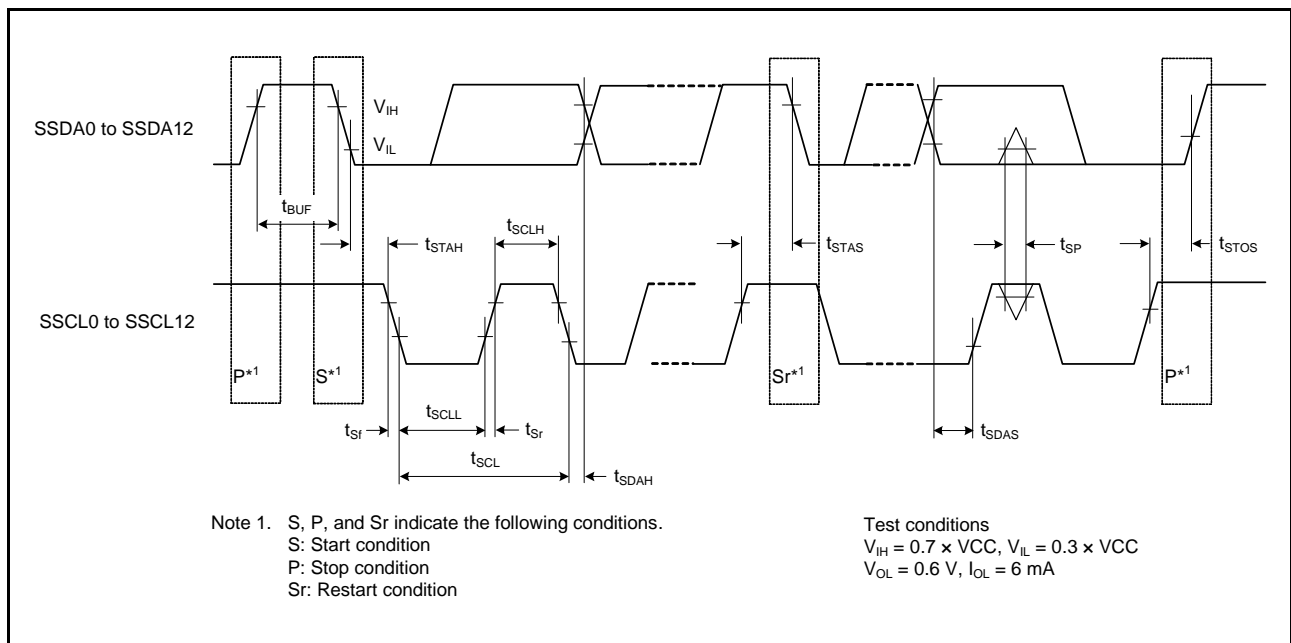

Figure 2.56 Simple IIC Bus Interface Input/Output Timing

Table 2.38 Simple SPI Timing

Conditions: $V_{CC} = AV_{CC0} = AV_{CC1} = V_{CC_USB} = V_{BATT} = 2.7$ to 3.6 V, 2.7 V $\leq V_{REFH0} \leq AV_{CC0}$,
 $V_{SS} = AV_{SS0} = AV_{SS1} = V_{REFL0} = V_{SS_USB} = 0$ V,
 $PCLKA = 8$ to 120 MHz, $PCLKB = 8$ to 60 MHz, $T_a = T_{opr}$,
 Output load conditions: $V_{OH} = 0.5 \times V_{CC}$, $V_{OL} = 0.5 \times V_{CC}$, $C = 30$ pF,
 High-drive output is selected by the driving ability control register.

Item		Symbol	Min.	Max.	Unit*1	Test Conditions
Simple SPI	SCK clock cycle output (master)	t_{SPcyc}	4	65536	t_{PAcyc}	Figure 2.57
	SCK clock cycle input (slave)		8	65536		
	SCK clock high pulse width	t_{SPCKWH}	0.4	0.6	t_{SPcyc}	
	SCK clock low pulse width	t_{SPCKWL}	0.4	0.6	t_{SPcyc}	
	SCK clock rise/fall time	t_{SPCKr} , t_{SPCKf}	—	20	ns	
	Data input setup time	t_{SU}	33.3	—	ns	Figure 2.58 to Figure 2.61
	Data input hold time	t_H	33.3	—	ns	
	SS input setup time	t_{LEAD}	1	—	t_{SPcyc}	t_{SPcyc}
	SS input hold time	t_{LAG}	1	—	t_{SPcyc}	
	Data output delay time	t_{OD}	—	33.3	ns	t_{PBcyc}
	Data output hold time	t_{OH}	-10	—	ns	
	Data rise/fall time	t_{Dr} , t_{Df}	—	16.6	ns	
	SS input rise/fall time	t_{SSLr} , t_{SSLf}	—	16.6	ns	
	Slave access time	t_{SA}	—	5	t_{PBcyc}	
	Slave output release time	t_{REL}	—	5	t_{PBcyc}	Figure 2.60, Figure 2.61

Note 1. t_{PAcyc} : PCLKA cycle, t_{PBcyc} : PCLKB cycle

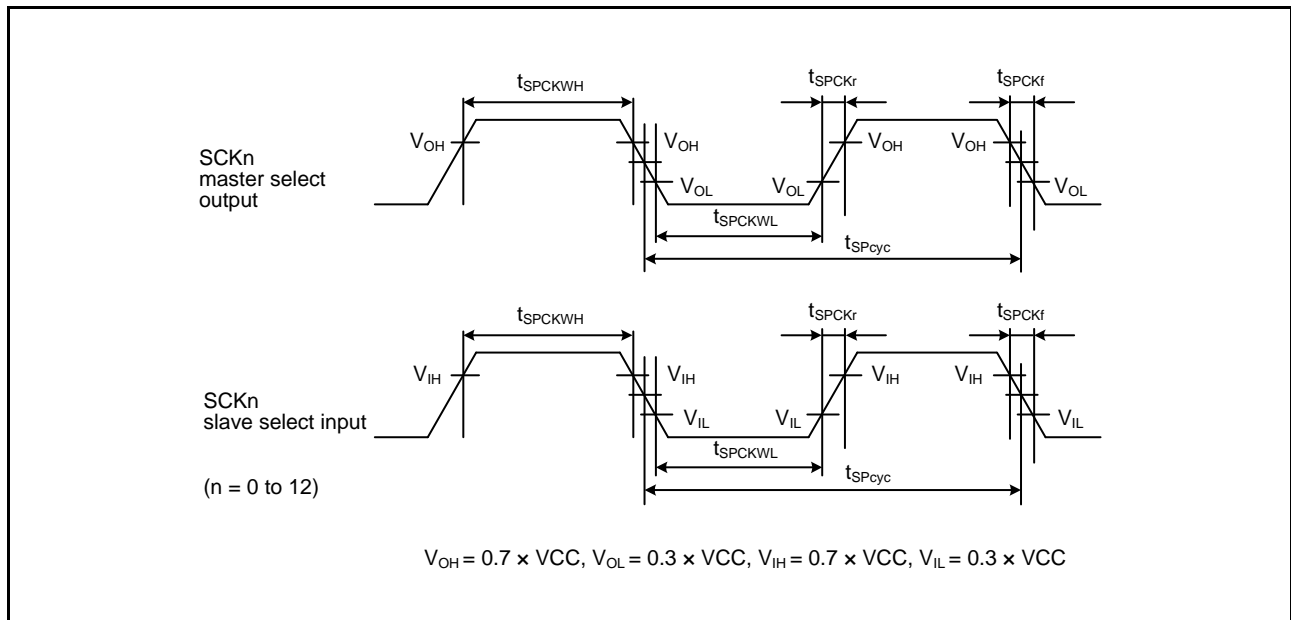

Figure 2.57 Simple SPI Clock Timing

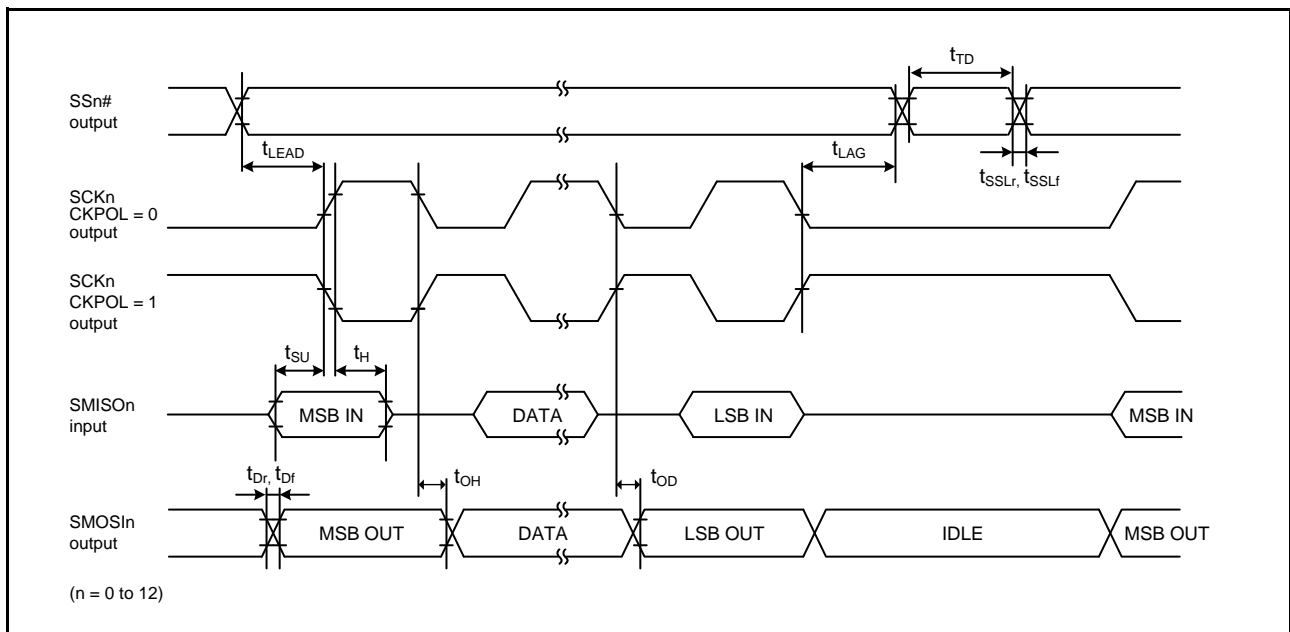

Figure 2.58 Simple SPI Timing (Master, CKPH = 1)

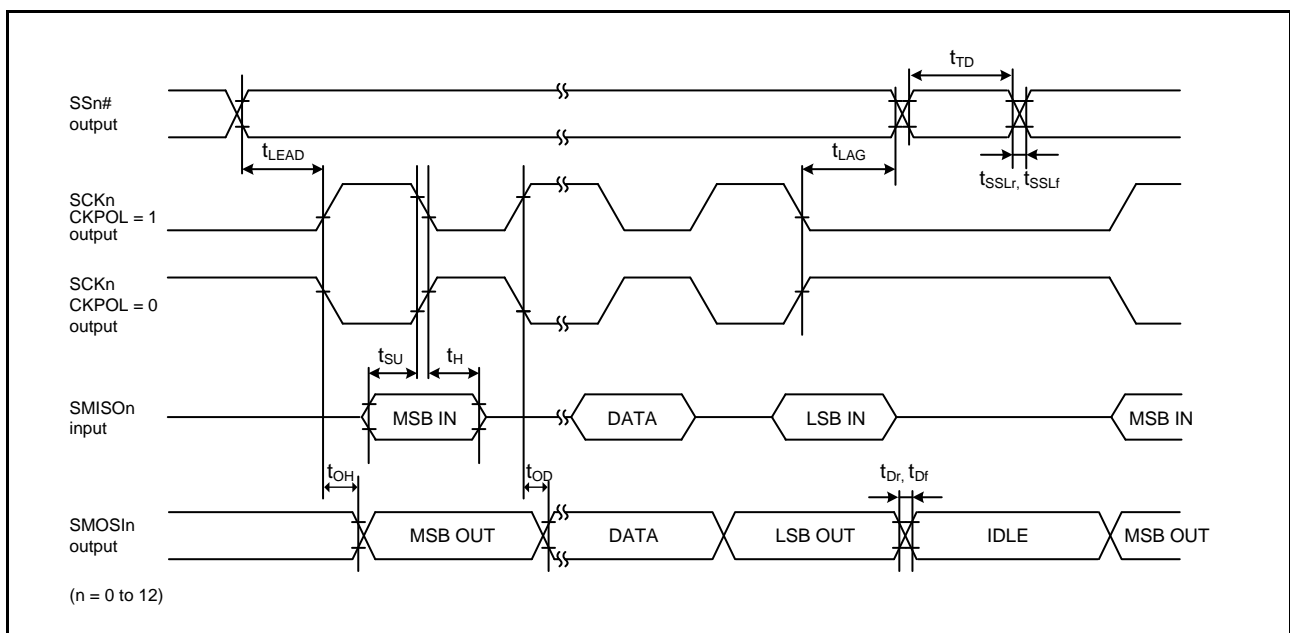

Figure 2.59 Simple SPI Timing (Master, CKPH = 0)

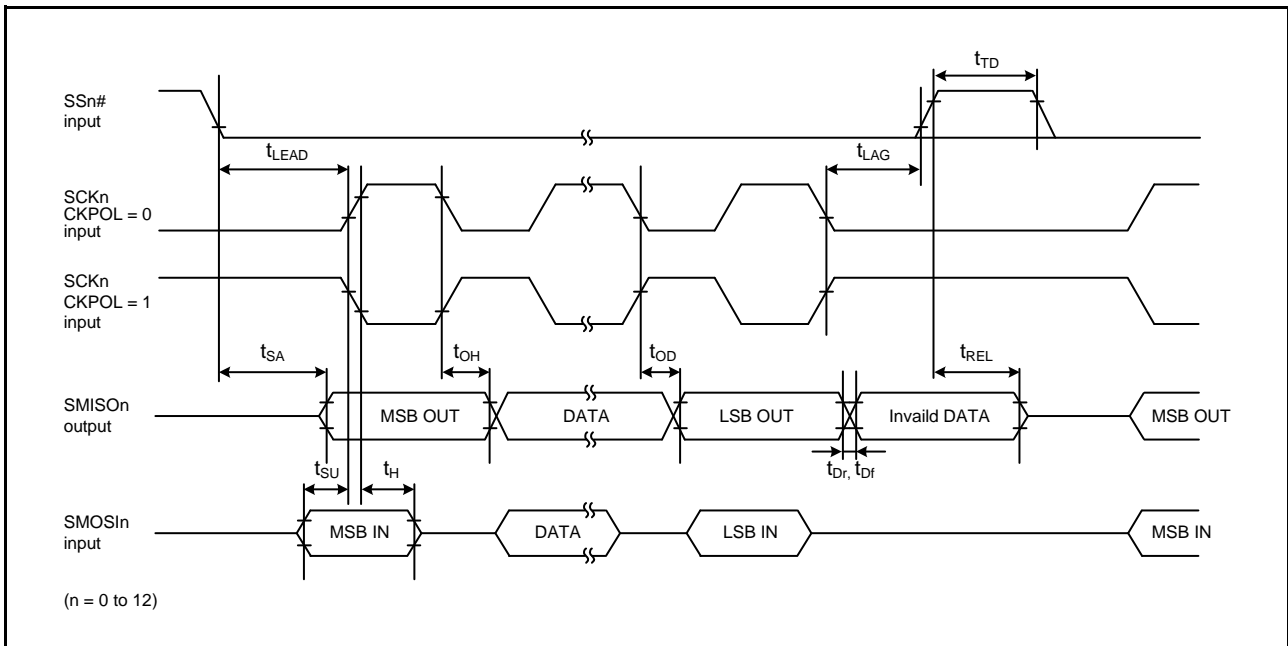

Figure 2.60 Simple SPI Timing (Slave, CKPH = 1)

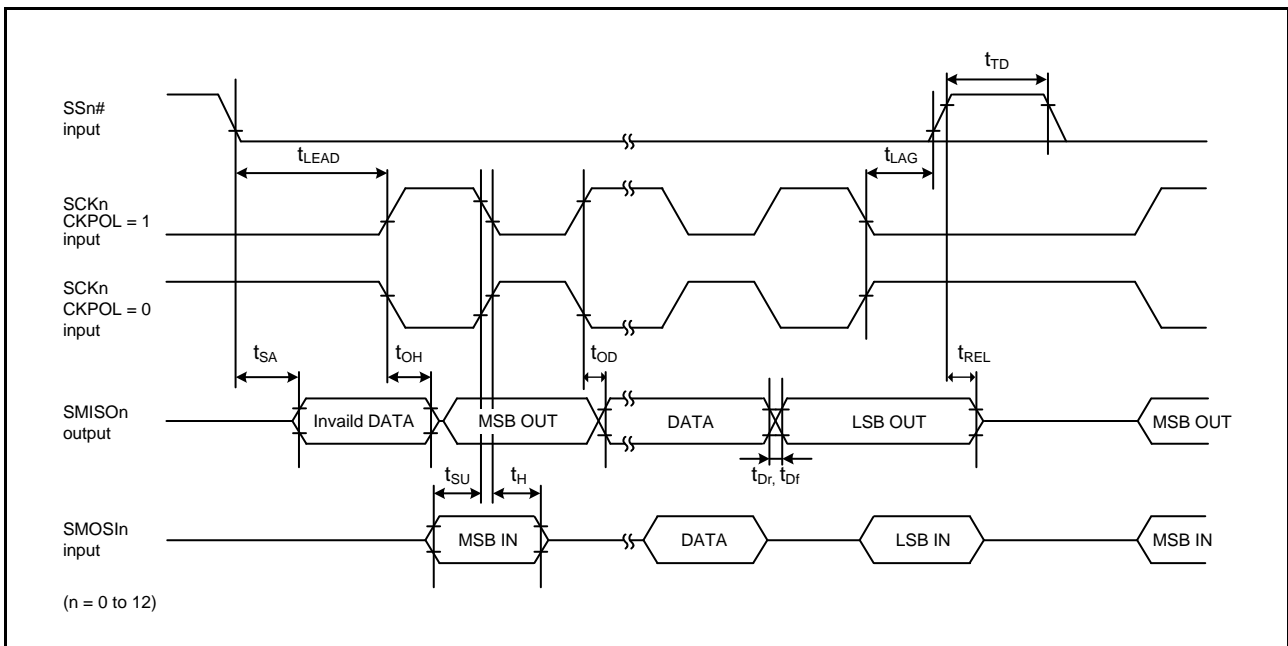

Figure 2.61 Simple SPI Timing (Slave, CKPH = 0)

2.4.7.10 RIIC

Table 2.39 RIIC Timing

Conditions: VCC = AVCC0 = AVCC1 = VCC_USB = V_{BATT} = 2.7 to 3.6 V, 2.7 V ≤ VREFH0 ≤ AVCC0,
VSS = AVSS0 = AVSS1 = VREFL0 = VSS_USB = 0 V,
PCLKA = 8 to 120 MHz, PCLKB = 8 to 60 MHz, T_a = T_{opr},
High-drive output is selected by the driving ability control register.

Item		Symbol	Min.*1	Max.	Unit	Test Conditions
RIIC (Standard-mode, SMBus) ICFER.FMPE = 0	SCL input cycle time	t _{SCL}	6(12) × t _{IICcyc} + 1300	—	ns	Figure 2.62
	SCL input high pulse width	t _{SCLH}	3(6) × t _{IICcyc} + 300	—	ns	
	SCL input low pulse width	t _{SCLL}	3(6) × t _{IICcyc} + 300	—	ns	
	SCL, SDA input rise time	t _{Sr}	—	1000	ns	
	SCL, SDA input fall time	t _{Sf}	—	300	ns	
	SCL, SDA input spike pulse removal time	t _{SP}	0	1(4) × t _{IICcyc}	ns	
	SDA input bus free time	t _{BUF}	3(6) × t _{IICcyc} + 300	—	ns	
	Start condition input hold time	t _{STAH}	t _{IICcyc} + 300	—	ns	
	Restart condition input setup time	t _{STAS}	1000	—	ns	
	Stop condition input setup time	t _{STOS}	1000	—	ns	
	Data input setup time	t _{SDAS}	t _{IICcyc} + 50	—	ns	
	Data input hold time	t _{SDAH}	0	—	ns	
	SCL, SDA capacitive load	C _b *2	—	400	pF	
RIIC (Fast-mode) ICFER.FMPE = 0	SCL input cycle time	t _{SCL}	6(12) × t _{IICcyc} + 600	—	ns	
	SCL input high pulse width	t _{SCLH}	3(6) × t _{IICcyc} + 300	—	ns	
	SCL input low pulse width	t _{SCLL}	3(6) × t _{IICcyc} + 300	—	ns	
	SCL, SDA input rise time	t _{Sr}	20 × (External pull-up voltage/5.5V)	300	ns	
	SCL, SDA input fall time	t _{Sf}	20 × (External pull-up voltage/5.5V)	300	ns	
	SCL, SDA input spike pulse removal time	t _{SP}	0	1(4) × t _{IICcyc}	ns	
	SDA input bus free time	t _{BUF}	3(6) × t _{IICcyc} + 300	—	ns	
	Start condition input hold time	t _{STAH}	t _{IICcyc} + 300	—	ns	
	Restart condition input setup time	t _{STAS}	300	—	ns	
	Stop condition input setup time	t _{STOS}	300	—	ns	
	Data input setup time	t _{SDAS}	t _{IICcyc} + 50	—	ns	
	Data input hold time	t _{SDAH}	0	—	ns	
	SCL, SDA capacitive load	C _b *2	—	400	pF	
RIIC (Fast-mode+) ICFER.FMPE = 1	SCL input cycle time	t _{SCL}	6(12) × t _{IICcyc} + 240	—	ns	
	SCL input high pulse width	t _{SCLH}	3(6) × t _{IICcyc} + 120	—	ns	
	SCL input low pulse width	t _{SCLL}	3(6) × t _{IICcyc} + 120	—	ns	
	SCL, SDA input rise time	t _{Sr}	—	120	ns	
	SCL, SDA input fall time	t _{Sf}	—	120	ns	
	SCL, SDA input spike pulse removal time	t _{SP}	0	1(4) × t _{IICcyc}	ns	
	SDA input bus free time	t _{BUF}	3(6) × t _{IICcyc} + 120	—	ns	
	Start condition input hold time	t _{STAH}	t _{IICcyc} + 120	—	ns	
	Restart condition input setup time	t _{STAS}	120	—	ns	
	Stop condition input setup time	t _{STOS}	120	—	ns	
	Data input setup time	t _{SDAS}	t _{IICcyc} + 20	—	ns	
	Data input hold time	t _{SDAH}	0	—	ns	
	SCL, SDA capacitive load	C _b *2	—	550	pF	

Note: t_{IICcyc} : RIIC internal reference clock (IIC ϕ) cycle

Note 1. The value within parentheses is applicable when the value of the ICMR3.NF[1:0] bits is 11b while the digital filter is enabled by the setting ICFER.NFE = 1.

Note 2. C_b is the total capacitance of the bus lines.

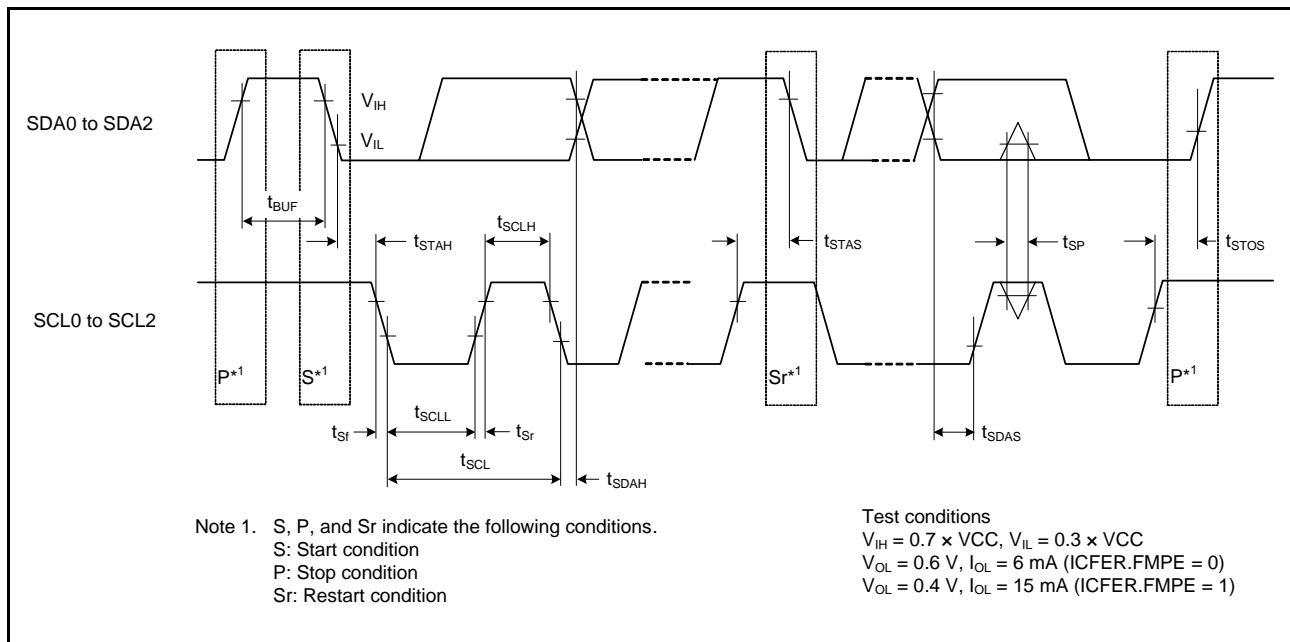

Figure 2.62 RIIC Bus Interface Input/Output Timing

2.4.7.11 RSPI

Table 2.40 RSPI Timing

Conditions: $V_{CC} = AVCC0 = AVCC1 = V_{CC_USB} = V_{BATT} = 2.7$ to 3.6 V, 2.7 V \leq $V_{REFH0} \leq AVCC0$,
 $V_{SS} = AVSS0 = AVSS1 = V_{REFL0} = V_{SS_USB} = 0$ V,
 $PCLKA = 8$ to 120 MHz, $PCLKB = 8$ to 60 MHz, $T_a = T_{opr}$,
 Output load conditions: $V_{OH} = 0.5 \times V_{CC}$, $V_{OL} = 0.5 \times V_{CC}$, $C = 30$ pF,
 High-drive output is selected by the driving ability control register.

Item		Symbol	Min.*1	Max.*1	Unit*1	Test Conditions*2		
RSPI	RSPCK clock cycle	Master	t_{SPCyc}	2	—	t_{PACyc}	Figure 2.63	
		Slave		4	—			
	RSPCK clock high pulse width	Master	t_{SPCKWH}	$(t_{SPCyc} - t_{SPCKr} - t_{SPCKf}) / 2 - 3$	—	ns		Figure 2.64 to Figure 2.69
		Slave		$(t_{SPCyc} - t_{SPCKr} - t_{SPCKf}) / 2$	—			
	RSPCK clock low pulse width	Master	t_{SPCKWL}	$(t_{SPCyc} - t_{SPCKr} - t_{SPCKf}) / 2 - 3$	—	ns		
		Slave		$(t_{SPCyc} - t_{SPCKr} - t_{SPCKf}) / 2$	—			
	RSPCK clock rise/fall time	Output	t_{SPCKr} , t_{SPCKf}	—	5	ns		
		Input		—	1	μ s		
	Data input setup time	Master	t_{SU}	6	—	ns		
		Slave		8.3	—			
	Data input hold time	Master	PCLKA division ratio set to 1/2	t_{HF}	0	—	ns	
			PCLKA division ratio set to a value other than 1/2	t_H	t_{PACyc}	—		
		Slave			8.3	—		
	SSL setup time	Master	t_{LEAD}	1	8	t_{SPCyc}		
		Slave		6	—	t_{PACyc}		
	SSL hold time	Master	t_{LAG}	1	8	t_{SPCyc}		
		Slave		6	—	t_{PACyc}		
	Data output delay time	Master	t_{OD}	—	6.3	ns		
		Slave		—	28			
	Data output hold time	Master	t_{OH}	0	—	ns		
Slave			0	—				
Successive transmission delay time	Master	t_{TD}	$t_{SPCyc} + 2 \times t_{PACyc}$	$8 \times t_{SPCyc} + 2 \times t_{PACyc}$	ns			
	Slave		$6 \times t_{PACyc}$	—				
MOSI and MISO rise/fall time	Output	t_{Dr} , t_{Df}	—	5	ns			
	Input		—	1	μ s			
SSL rise/fall time	Output	t_{SSLr} , t_{SSLf}	—	5	ns			
	Input		—	1	μ s			
Slave access time		t_{SA}	—	$2 \times t_{PACyc} + 28$	ns	Figure 2.68, Figure 2.69		
Slave output release time		t_{REL}	—	$2 \times t_{PACyc} + 28$	ns			

Note 1. t_{PACyc} : PCLKA cycle

Note 2. We recommend using pins that have a letter (“-A”, “-B”, etc.) to indicate group membership appended to their names as groups. For the RSPI interface, the AC portion of the electrical characteristics is measured for each group.

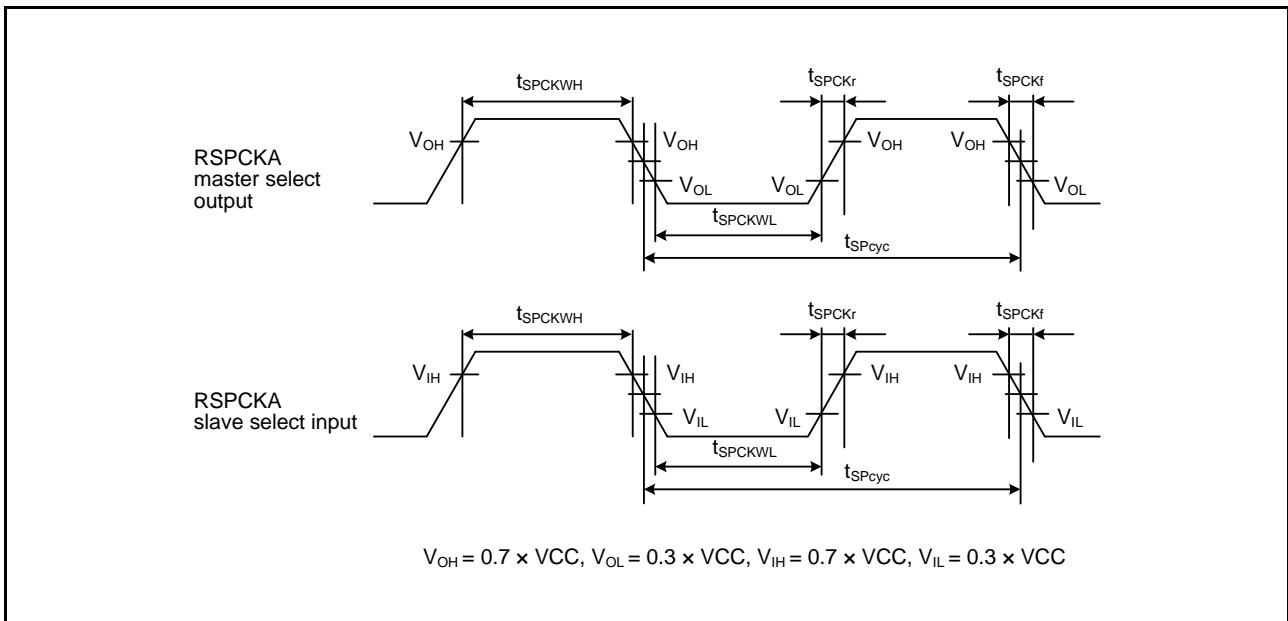

Figure 2.63 RSPCKA Clock Timing

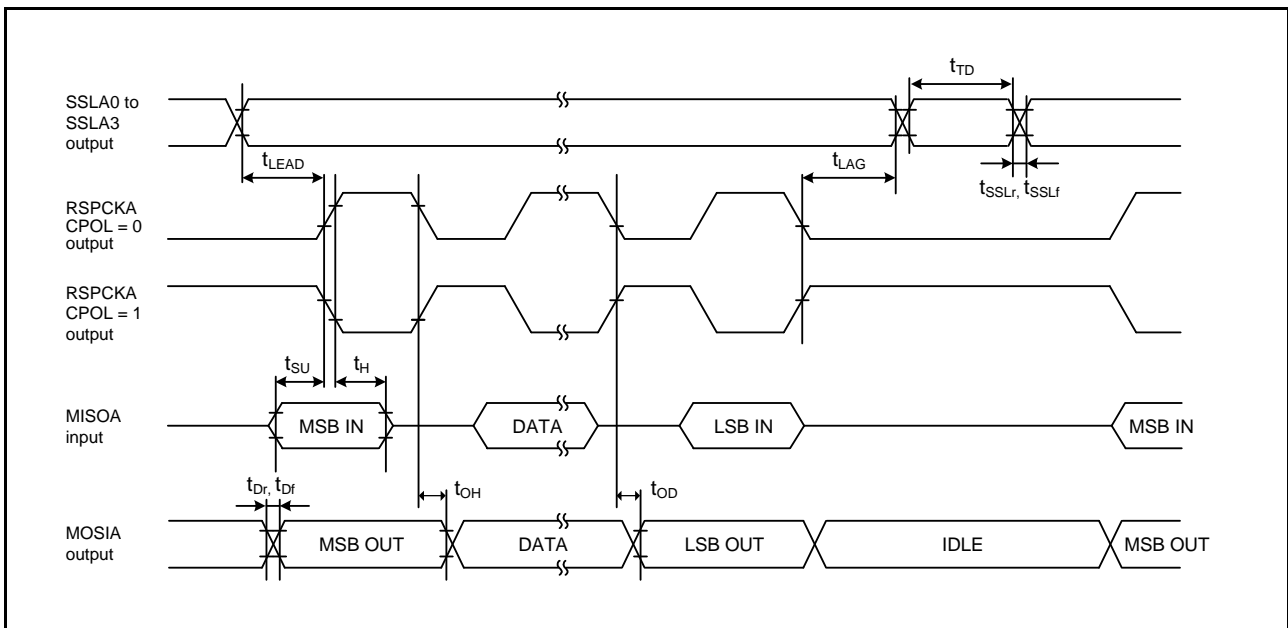

Figure 2.64 RSPCKA Timing (Master, CPHA = 0) (Bit Rate: PCLKA Division Ratio Set to a Value Other Than 1/2)

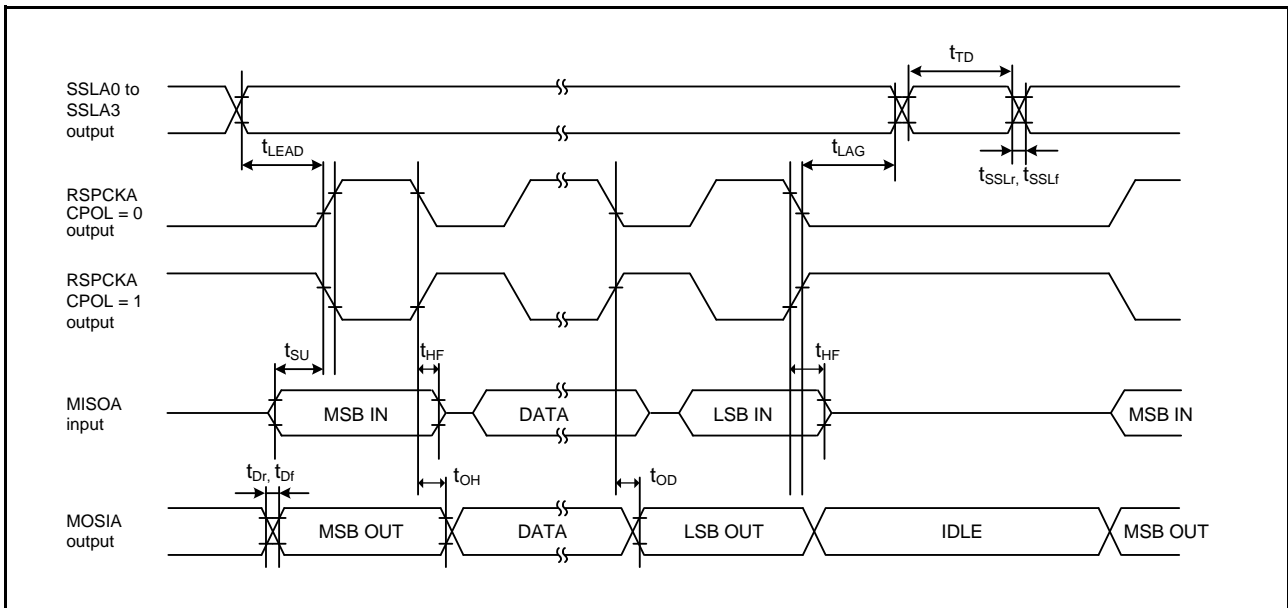

Figure 2.65 RSPI Timing (Master, CPHA = 0) (Bit Rate: PCLKA Division Ratio Set to 1/2)

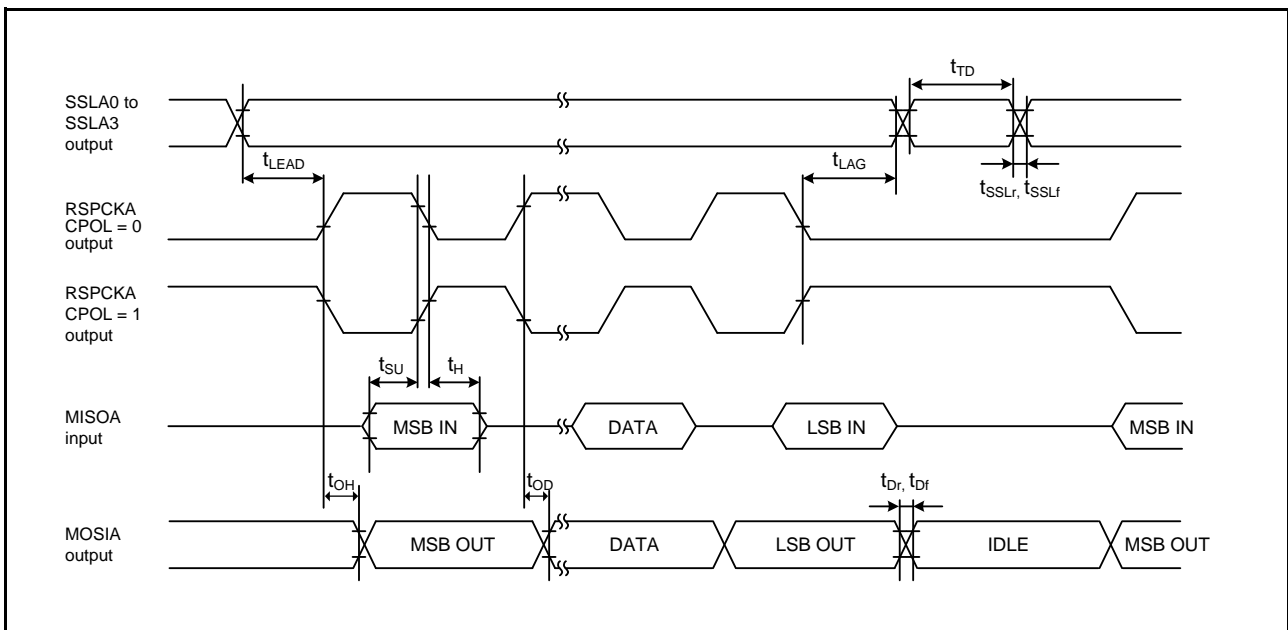

Figure 2.66 RSPI Timing (Master, CPHA = 1) (Bit Rate: PCLKA Division Ratio Set to a Value Other Than 1/2)

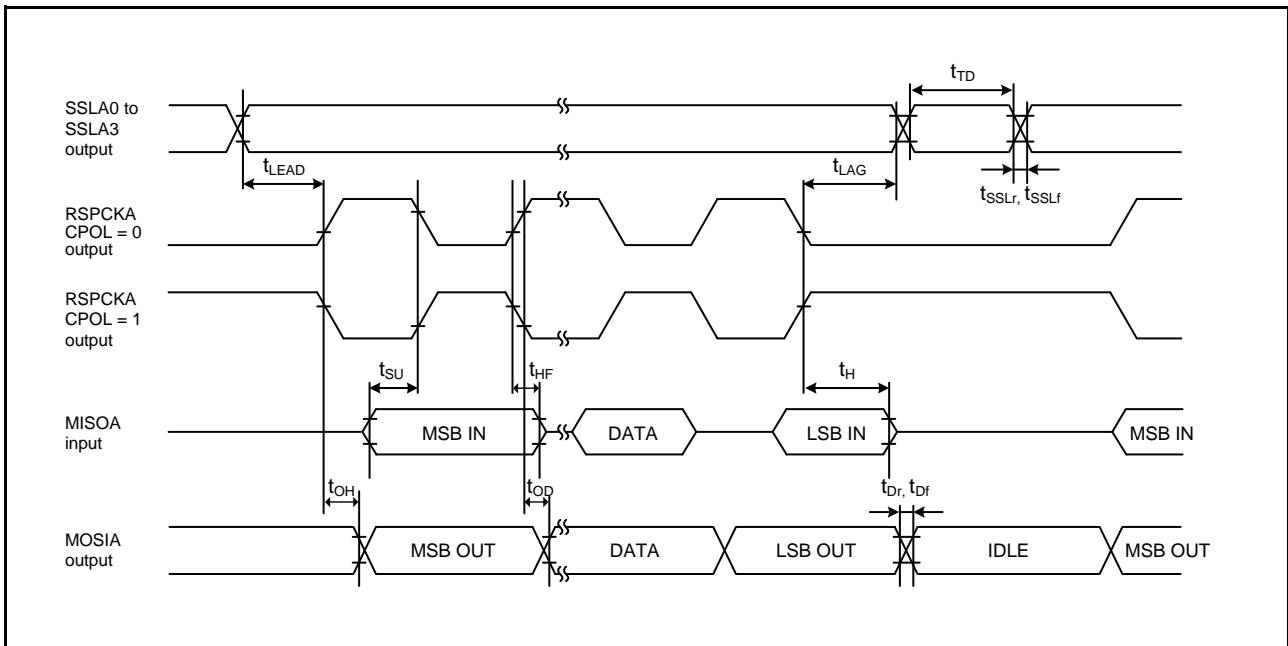

Figure 2.67 RSPI Timing (Master, CPHA = 1) (Bit Rate: PCLKA Division Ratio Set to 1/2)

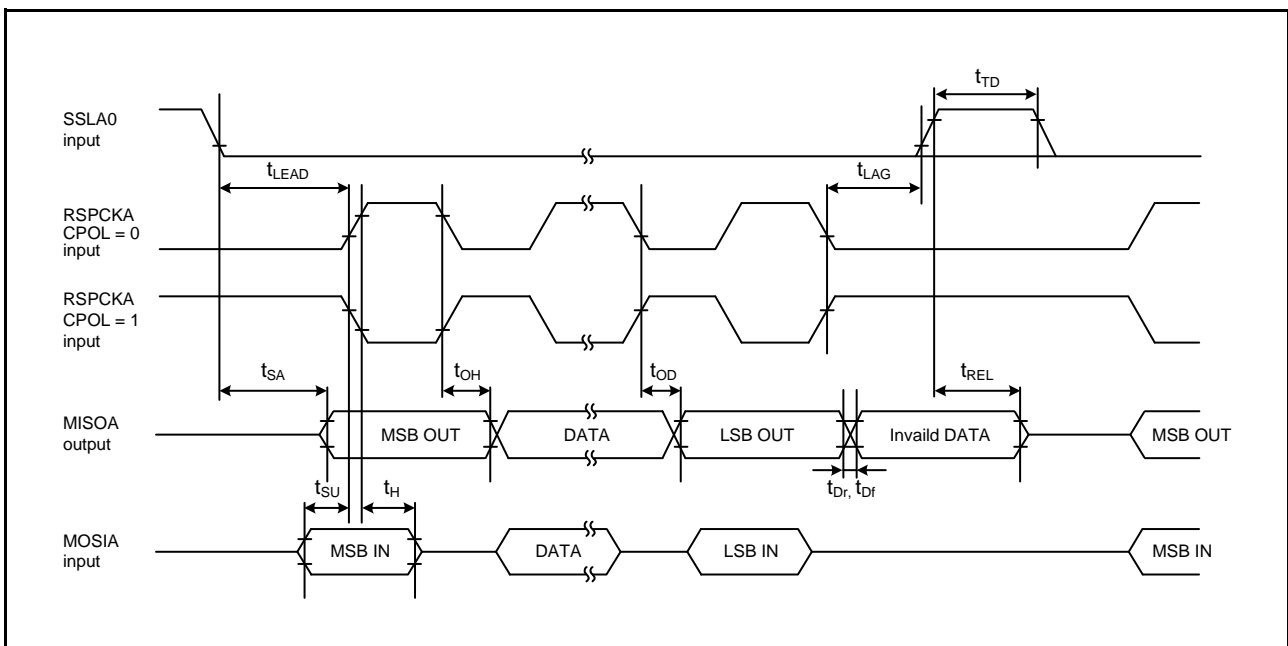

Figure 2.68 RSPI Timing (Slave, CPHA = 0)

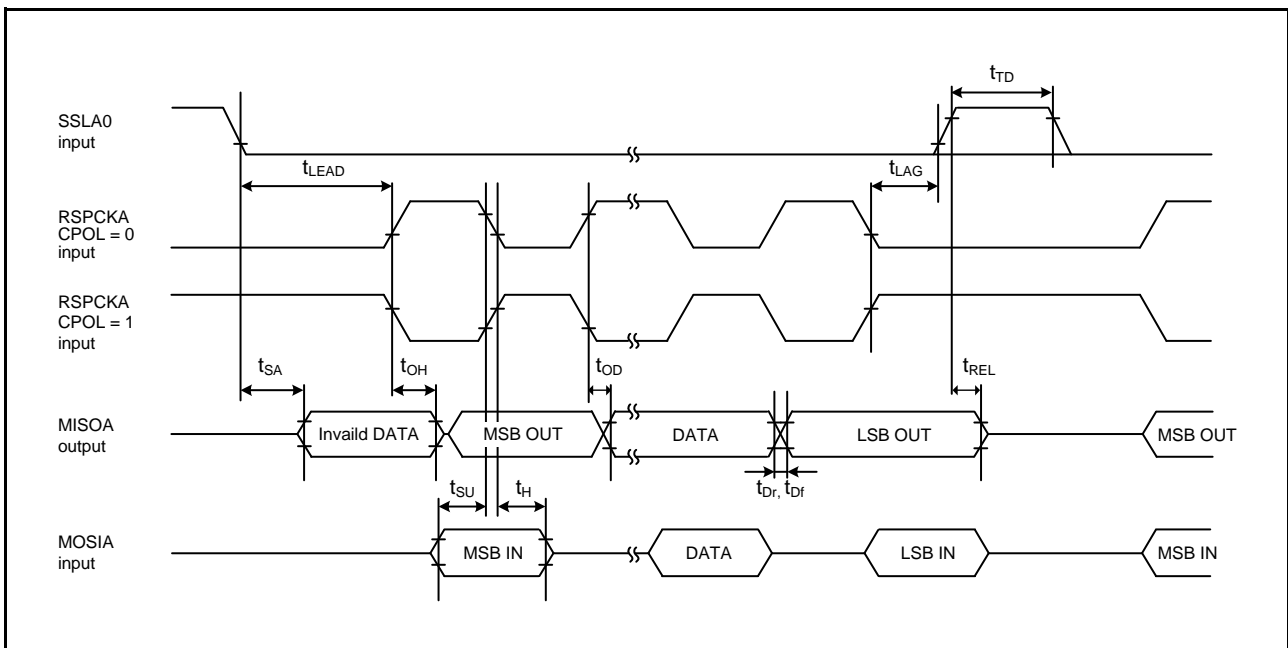

Figure 2.69 RSPI Timing (Slave, CPHA = 1)

2.4.7.12 QSPI

Table 2.41 QSPI Timing

Conditions: $V_{CC} = AVCC0 = AVCC1 = VCC_USB = V_{BATT} = 2.7$ to 3.6 V, 2.7 V \leq $V_{REFH0} \leq AVCC0$,
 $V_{SS} = AVSS0 = AVSS1 = V_{REFL0} = VSS_USB = 0$ V,
 $PCLKA = 8$ to 120 MHz, $PCLKB = 8$ to 60 MHz, $T_a = T_{opr}$,
 Output load conditions: $V_{OH} = 0.5 \times V_{CC}$, $V_{OL} = 0.5 \times V_{CC}$, $C = 30$ pF,
 High-drive output is selected by the driving ability control register.

Item	Symbol	Min.	Max.	Unit*1	Test Conditions*2
QSPI	QSPCLK clock cycle	t_{QScyc}	2	4080	t_{PBcyc} Figure 2.70
	Data input setup time	t_{Su}	6.5	—	ns Figure 2.71, Figure 2.72
	Data input hold time	t_{IH}	5	—	ns
	SS setup time	t_{LEAD}	1.5	8.5	t_{QScyc}
	SS hold time	t_{LAG}	1	8	t_{QScyc}
	Data output delay time	t_{OD}	—	10.0	ns
	Data output hold time	t_{OH}	-5	—	ns
	Successive transmission delay time	t_{TD}	1	8	t_{QScyc}

Note 1. t_{PBcyc} : PCLKB cycle

Note 2. We recommend using pins that have a letter (“-A”, “-B”, etc.) to indicate group membership appended to their names as groups. For the QSPI interface, the AC portion of the electrical characteristics is measured for each group.

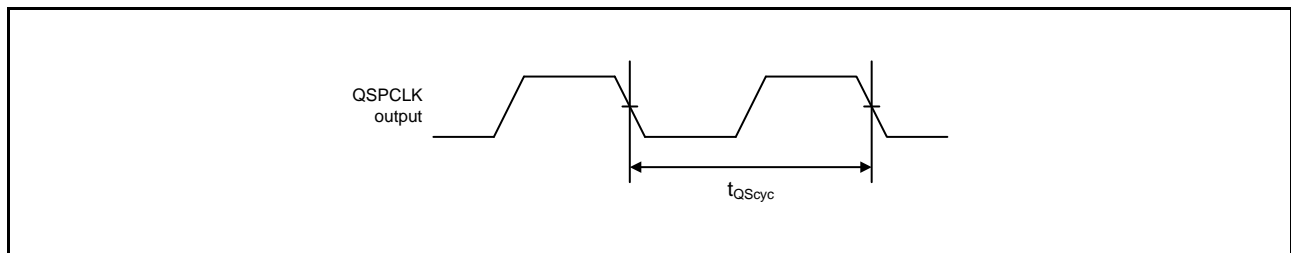

Figure 2.70 QSPI Clock Timing

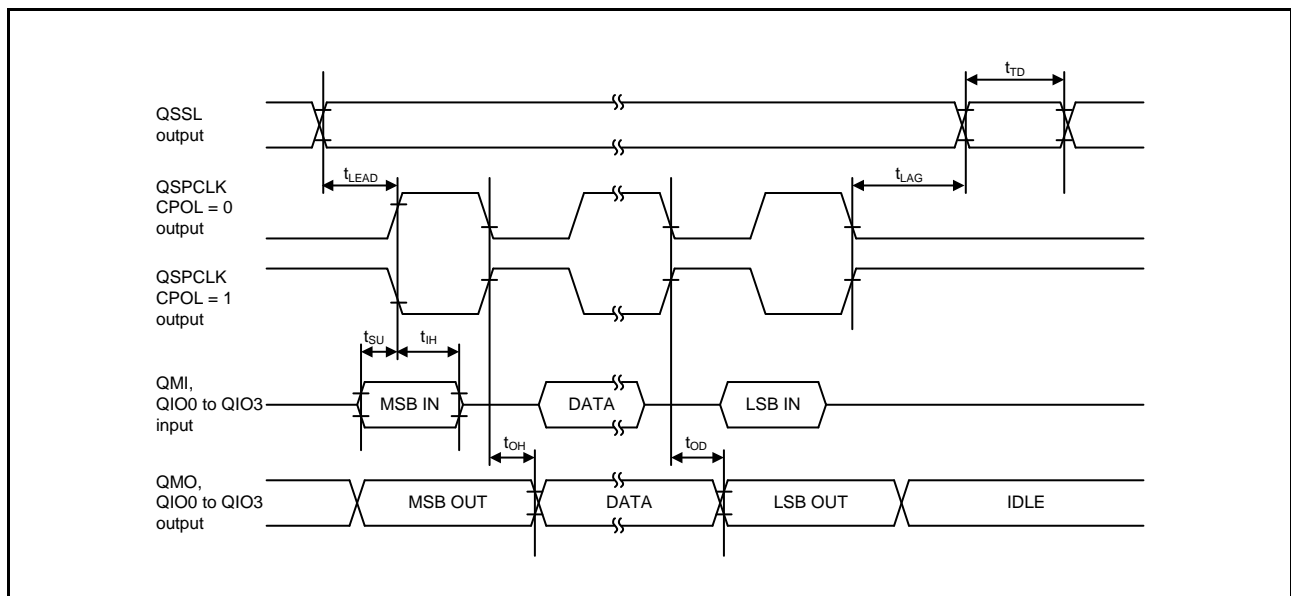

Figure 2.71 Transmit/Receive Timing (CPHA = 0)

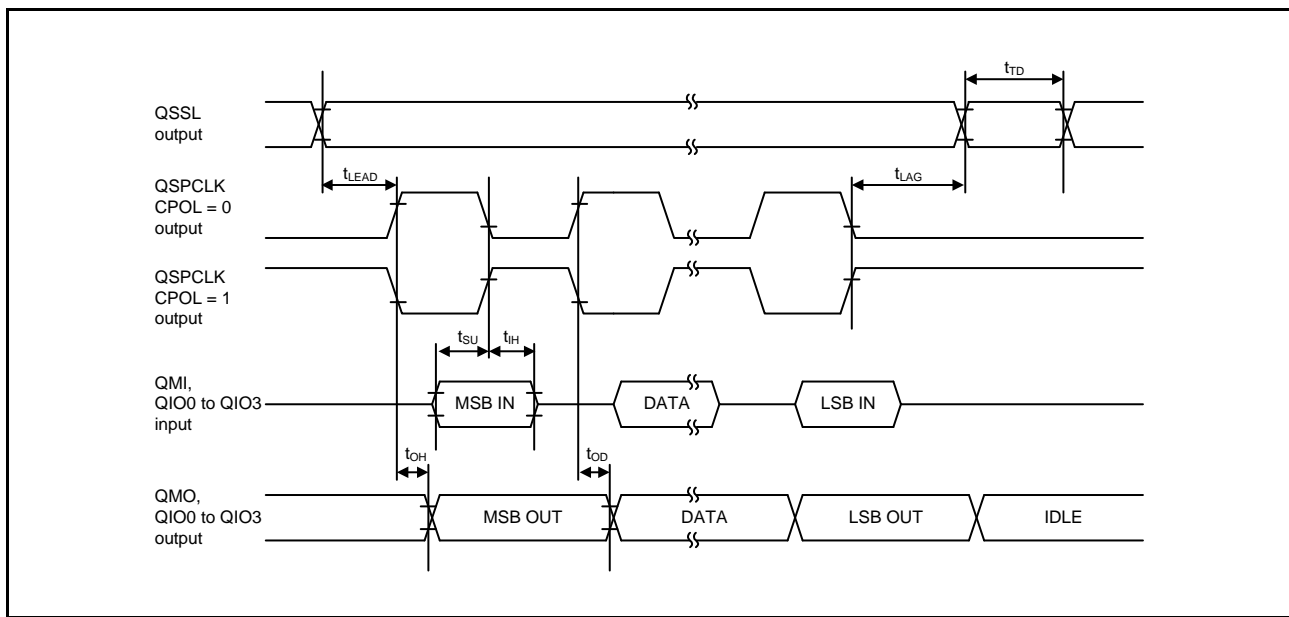

Figure 2.72 Transmit/Receive Timing (CPHA = 1)

2.4.7.13 SSIE

Table 2.42 Expansion Serial Sound Interface Timing

Conditions: $V_{CC} = AV_{CC0} = AV_{CC1} = V_{CC_USB} = V_{BATT} = 2.7$ to 3.6 V, $V_{REFH0} = 2.7$ V to AV_{CC0} ,
 $V_{SS} = AV_{SS0} = AV_{SS1} = V_{REFL0} = V_{SS_USB} = 0$ V,
 $PCLKB = 8$ to 60 MHz, $T_a = T_{opr}$,
 Output load conditions: $V_{OH} = 0.5 \times V_{CC}$, $V_{OL} = 0.5 \times V_{CC}$, $C = 30$ pF,
 High-drive output is selected by the driving ability control register.

Item		Symbol	Min.	Max.	Unit	Test Conditions	
AUDIO_CLK	Cycle	t_{EXcyc}	20	—	ns	Figure 2.73	
	High/low level	t_{EXL}/t_{EXH}	0.4	0.6	t_{EXcyc}		
SSIBCKn	Cycle	Master	t_O	80	—	ns	Figure 2.74
		Slave	t_I	80	—	ns	
	Output clock high level	Master	t_{HC}	0.35	—	t_O	
	Output clock low level		t_{LC}	0.35	—	t_O	
	Input clock high level	Slave	t_{HC}	0.35	—	t_I	
	Input clock low level		t_{LC}	0.35	—	t_I	
	Output clock rise time	Master	t_{RC}	—	0.15	t_O	
	Output clock fall time		t_{FC}	—	0.15	t_O	
	Input clock rise time	Slave	t_{RC}	—	0.15	t_I	
	Input clock fall time		t_{FC}	—	0.15	t_I	
SSILRCKn, SSITXD0, SSIRXD0, SSIDATA1	Input setup time	Master	t_{SR}	12	—	ns	Figure 2.75, Figure 2.76
		Slave		12	—	ns	
	Input hold time	Master	t_{HR}	8	—	ns	
		Slave		15	—	ns	
	Output delay time	Master	t_{DTR}	-10	5	ns	
		Slave		0	20	ns	
	Output delay time from when an SSILRCK0 signal is changed*1	Slave	t_{DTRW}	—	20	ns	Figure 2.77

n = 0, 1

Note 1. The SSIE has a single path for transmission in slave mode. To generate the data for transmission, the signals input through the SSILRCKn pin through the abovementioned path are used. After that, the data for transmission proceed to be used as the logical outputs to the SSITXD0 or SSIDATA1 pin.

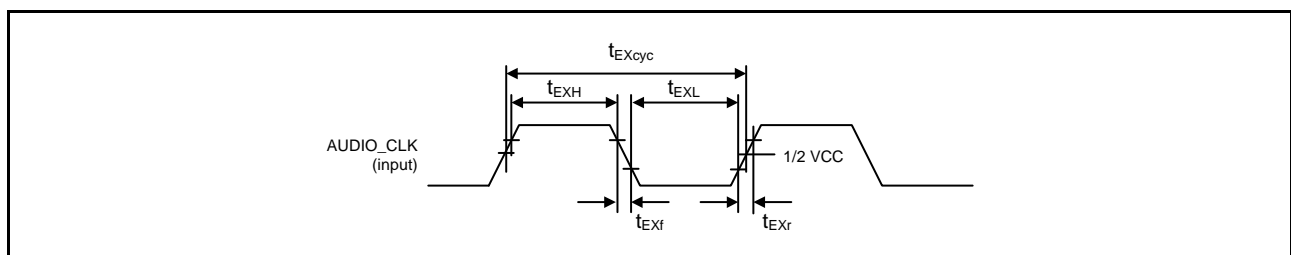

Figure 2.73 Clock Input Timing

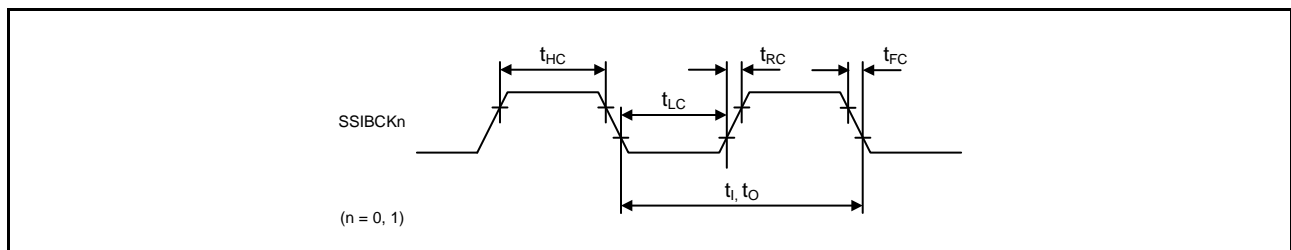

Figure 2.74 SSIE Clock Input/Output Timing

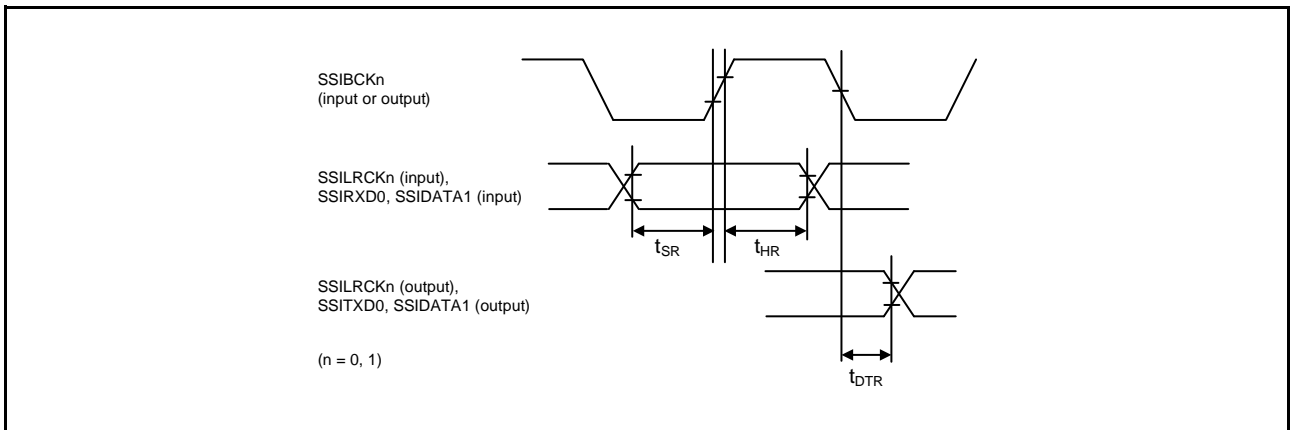

Figure 2.75 Transmission and Reception Timing for the SSIE Data When the SSICR.BCKP Bit is 0

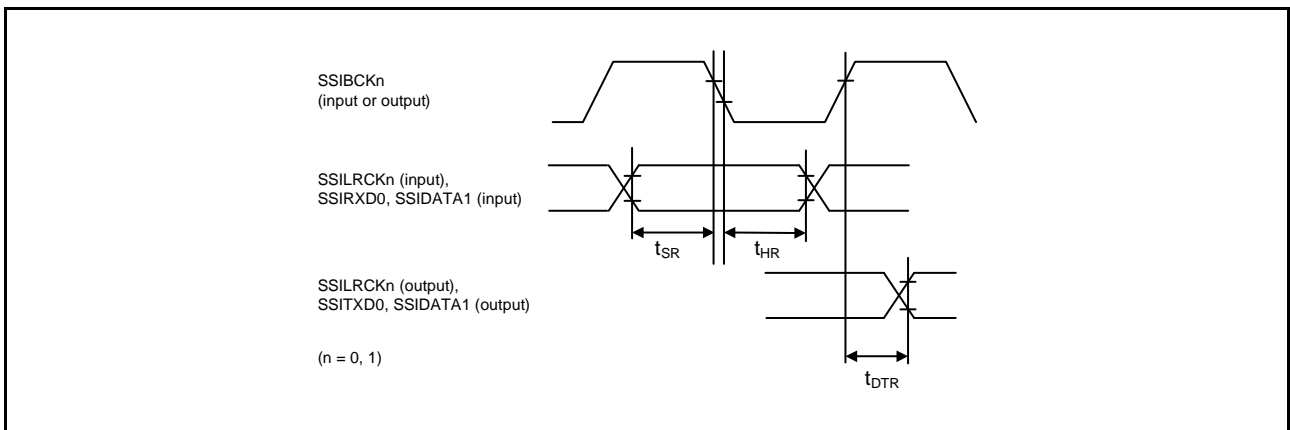

Figure 2.76 Transmission and Reception Timing for the SSIE Data When the SSICR.BCKP Bit is 1

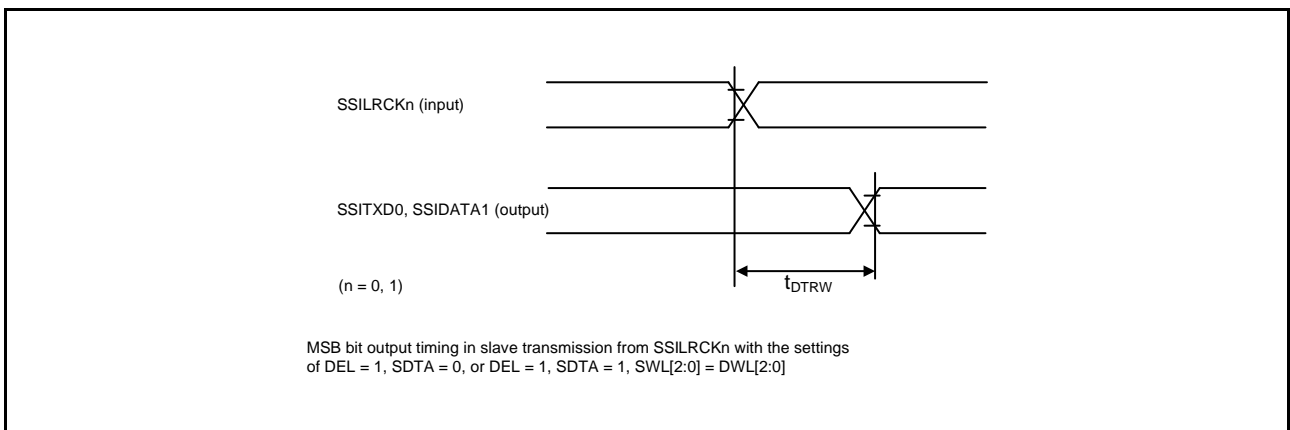

Figure 2.77 Output Delay of the SSIE Data from When an SSILRCKn Signal is Changed

2.4.7.14 PMGI

Table 2.43 PMGI Timing

Conditions: $V_{CC} = AVCC0 = AVCC1 = V_{CC_USB} = V_{BATT} = 2.7$ to 3.6 V, 2.7 V $\leq V_{REFH0} \leq AVCC0$,
 $V_{SS} = AVSS0 = AVSS1 = V_{REFL0} = V_{SS_USB} = 0$ V,
 $ICLK = PCLKA = 8$ to 120 MHz, $PCLKB = BCLK = SDCLK = 8$ to 60 MHz, $T_a = T_{opr}$,
 Output load conditions: $V_{OH} = 0.5 \times V_{CC}$, $V_{OL} = 0.5 \times V_{CC}$, $C = 30$ pF,
 High-drive output is selected by the driving ability control register.

Item		Symbol	Min.	Max.	Unit	Test Conditions
PMGI	PMGIn_MDC output cycle	t_{MDC}	80	—	ns	Figure 2.78
	PMGIn_MDIO setup time (relative to PMGIn_MDC \uparrow)	t_{SMDIO}	20	—	ns	
	PMGIn_MDIO hold time (relative to PMGIn_MDC \uparrow)	t_{HMDIO}	0	—	ns	
	PMGIn_MDIO output delay time (relative to PMGIn_MDC \uparrow)	t_{DMDIO}	0	20	ns	

$n = 0, 1$

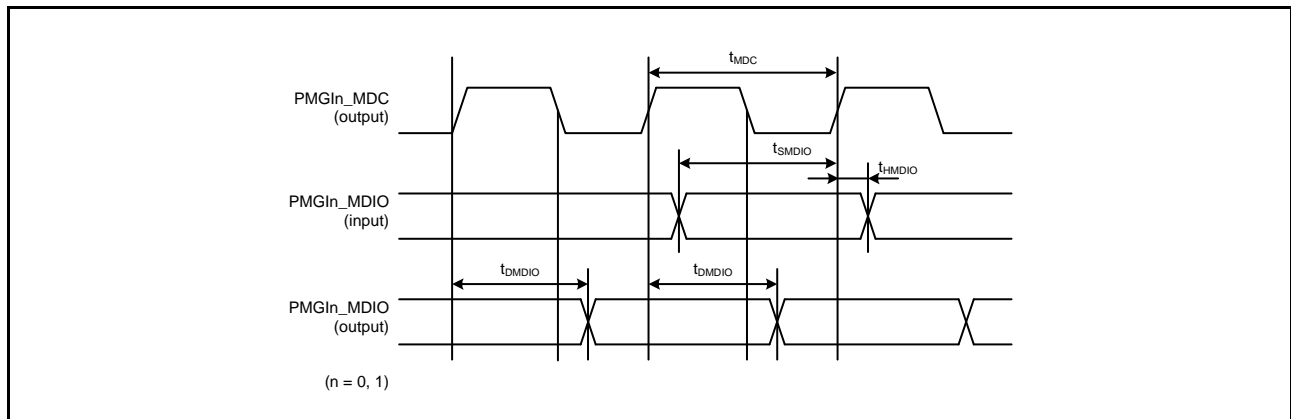

Figure 2.78 Timing of Serial Management Access

2.4.7.15 MMC

Table 2.44 MMC Host Interface Timing

Conditions: $V_{CC} = AVCC0 = AVCC1 = VCC_USB = V_{BATT} = 2.7$ to 3.6 V, 2.7 V $\leq V_{REFH0} \leq AVCC0$,
 $V_{SS} = AVSS0 = AVSS1 = V_{REFL0} = VSS_USB = 0$ V,
 $PCLKA = 8$ to 120 MHz, $PCLKB = 8$ to 60 MHz, $T_a = T_{opr}$,
 Output load conditions: $V_{OH} = 0.5 \times V_{CC}$, $V_{OL} = 0.5 \times V_{CC}$, $C = 30$ pF,
 High-drive output is selected by the driving ability control register.

Item	Symbol	Min.*1	Max.	Unit	Test Conditions*2	
MMCIF	MMC_CLK clock cycle	t_{MMCPP}	$2 \times t_{PBcyc}$	—	ns	Figure 2.79
	MMC_CLK clock high level width	t_{MMCWH}	6.5	—	ns	
	MMC_CLK clock low level width	t_{MMCWL}	6.5	—	ns	
	MMC_CLK clock rising time	t_{MMCLH}	—	3	ns	
	MMC_CLK clock falling time	t_{MMCHL}	—	3	ns	
	MMC_CMD, MMC_D7 to MMC_D0 output data delay (data transfer mode)	t_{MMCODY}	-6.6	6.6	ns	
	MMC_CMD, MMC_D7 to MMC_D0 input data setup	t_{MMCISU}	8	—	ns	
	MMC_CMD, MMC_D7 to MMC_D0 input data hold	t_{MMCIH}	2.5	—	ns	

- Note 1. t_{PBcyc} : PCLKB cycle
- Note 2. We recommend using pins that have a letter ("A", "B", etc.) to indicate group membership appended to their names as groups. For the MMC interface, the AC portion of the electrical characteristics is measured for each group.

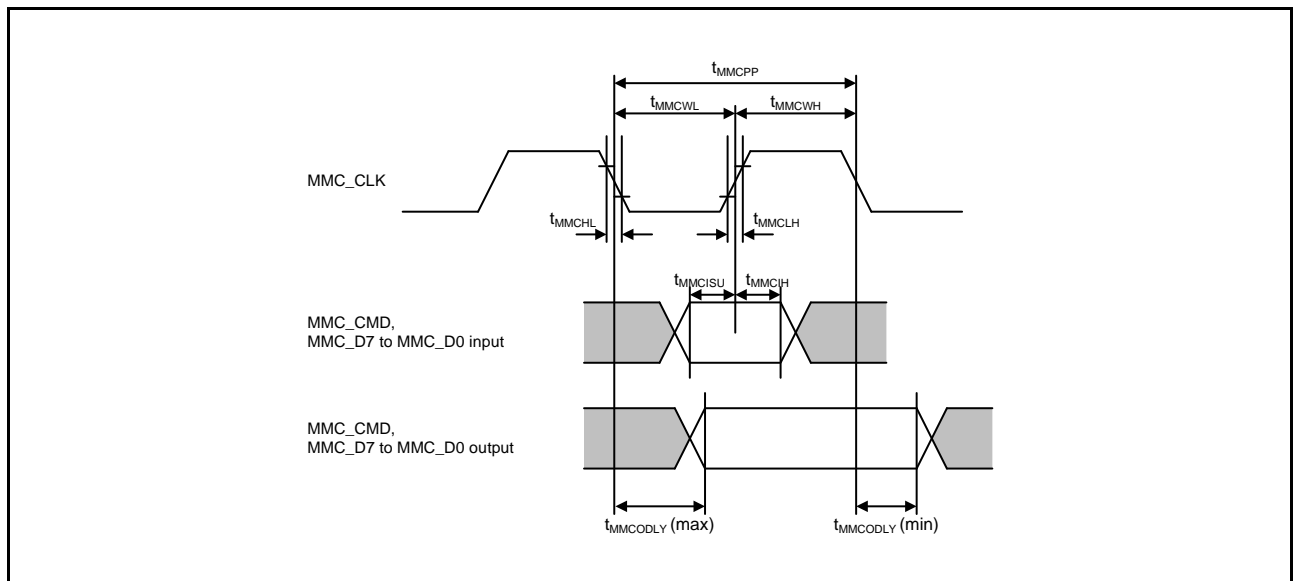

Figure 2.79 MMC Interface

2.4.7.16 SDHI

Table 2.45 SDHI Timing

Conditions: $V_{CC} = AVCC0 = AVCC1 = V_{CC_USB} = V_{BATT} = 2.7$ to $3.6V$, $2.7V \leq V_{REFH0} \leq AVCC0$,
 $V_{SS} = AVSS0 = AVSS1 = V_{REFL0} = V_{SS_USB} = 0V$,
 $PCLKA = 8$ to 120 MHz, $PCLKB = 8$ to 60 MHz, $T_a = T_{opr}$,
 Output load conditions: $V_{OH} = 0.5 \times V_{CC}$, $V_{OL} = 0.5 \times V_{CC}$, $C = 30pF$
 High-drive output is selected by the driving ability control register.

Item	Symbol	Min.	Max.	Unit	Test Conditions*1	
SDHI	SDHI_CLK output cycle time	$t_{PP(SD)}$	20	—	ns	Figure 2.80
	SDHI_CLK output width at high level	$t_{WH(SD)}$	$0.4 \times t_{PP(SD)}$	—	ns	
	SDHI_CLK output width at low level	$t_{WL(SD)}$	$0.4 \times t_{PP(SD)}$	—	ns	
	SDHI_CLK output rising time	$t_{TLH(SD)}$	—	3	ns	
	SDHI_CLK output falling time	$t_{THL(SD)}$	—	3	ns	
	SDHI_CMD, SDHI_D3 to SDHI_D0 output data delay (data transfer mode)	$t_{ODLY(SD)}$	-6.5	4	ns	
	SDHI_CMD, SDHI_D3 to SDHI_D0 input data setup time	$t_{SU(SD)}$	6	—	ns	
	SDHI_CMD, SDHI_D3 to SDHI_D0 input data hold time	$t_{IH(SD)}$	2	—	ns	

Note 1. We recommend using pin names that have a letter (“-A”, “-B”, etc.) to indicate group membership per group in the test. For the SDHI, the AC portion of the electrical characteristics is measured per group.

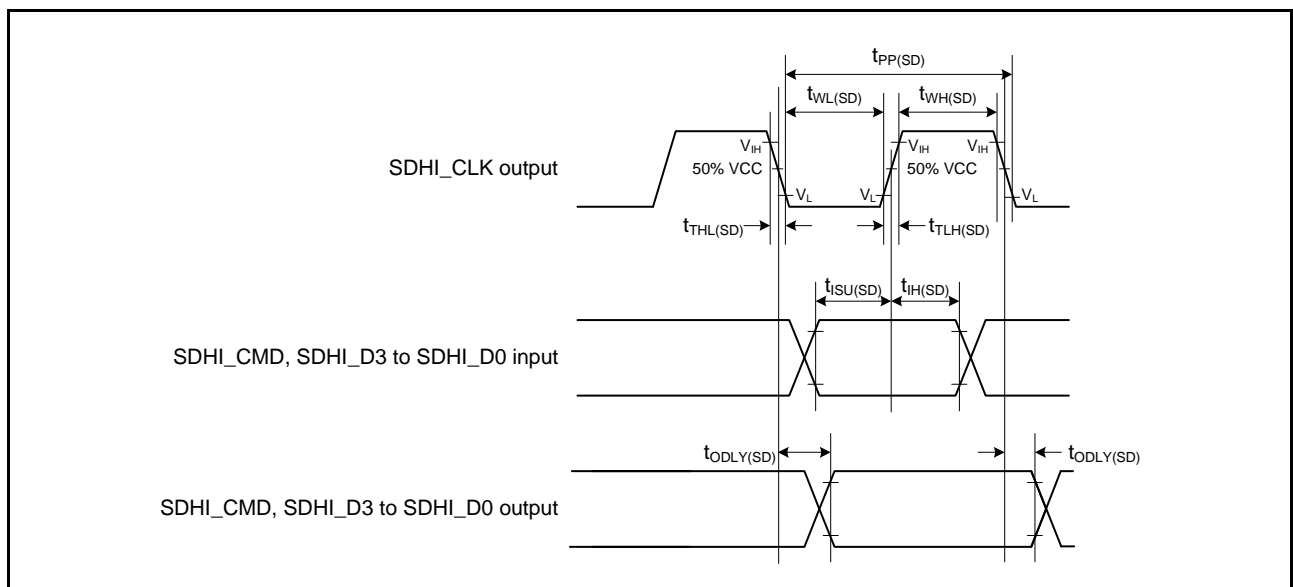

Figure 2.80 SD Host Interface Input/Output Signal Timing

2.4.7.17 ETHERC

Table 2.46 ETHERC Timing

Conditions: $VCC = AVCC0 = AVCC1 = VCC_USB = V_{BATT} = 2.7$ to 3.6 V, 2.7 V \leq $VREFH0 \leq AVCC0$,
 $VSS = AVSS0 = AVSS1 = VREFL0 = VSS_USB = 0$ V,
 $PCLKA = 8$ to 120 MHz, $PCLKB = 8$ to 60 MHz, $T_a = T_{opr}$,
 Output load conditions: $V_{OH} = 0.5 \times VCC$, $V_{OL} = 0.5 \times VCC$, $C = 30$ pF,
 RMII: High-drive output for the high-speed interface is selected in the drive capacity selection control register.
 MII: High-drive output is selected by the driving ability control register.

	Item	Symbol	Min.	Max.	Unit	Test Conditions
ETHERC (RMII)	REF50CK cycle time	T_{ck}	20	—	ns	Figure 2.81 to Figure 2.84
	REF50CK frequency Typ. 50 MHz	—	—	50 + 100 ppm	MHz	
	REF50CK duty	—	35	65	%	
	REF50CK rise/fall time	$T_{ckr/ckf}$	0.5	3.5	ns	
	RMII _n _xxxx*1 output delay time	T_{co}	2.5	15.0	ns	
	RMII _n _xxxx*2 setup time	T_{su}	3	—	ns	
	RMII _n _xxxx*2 hold time	T_{hd}	1	—	ns	
	RMII _n _xxxx*1, *2 rise/fall time	T_r/T_f	—	5	ns	
	ETn_WOL output delay time	t_{WOLd}	1	23.5	ns	Figure 2.85
ETHERC (MII)	ETn_TX_CLK cycle time	t_{Tcyc}	40	—	ns	—
	ETn_TX_EN output delay time	t_{TEND}	1	20	ns	Figure 2.86
	ETn_ETXD0 to ETn_ETXD3 output delay time	t_{MTDd}	1	20	ns	
	ETn_CRS setup time	t_{CRSs}	10	—	ns	
	ETn_CRS hold time	t_{CRSh}	10	—	ns	Figure 2.87
	ETn_COL setup time	t_{COLs}	10	—	ns	
	ETn_COL hold time	t_{COLh}	10	—	ns	
	ETn_RX_CLK cycle time	t_{TRcyc}	40	—	ns	—
	ETn_RX_DV setup time	t_{RDVs}	10	—	ns	Figure 2.88
	ETn_RX_DV hold time	t_{RDVh}	10	—	ns	
	ETn_ERXD0 to ETn_ERXD3 setup time	t_{MRDs}	10	—	ns	
	ETn_ERXD0 to ETn_ERXD3 hold time	t_{MRDh}	10	—	ns	Figure 2.89
	ETn_RX_ER setup time	t_{RErs}	10	—	ns	
	ETn_RX_ER hold time	t_{RErh}	10	—	ns	
		ETn_WOL output delay time	t_{WOLd}	1	23.5	ns

n = 0, 1

Note 1. RMII_n_TXD_EN, RMII_n_TXD1, RMII_n_TXD0

Note 2. RMII_n_CRS_DV, RMII_n_RXD1, RMII_n_RXD0, RMII_n_RX_ER

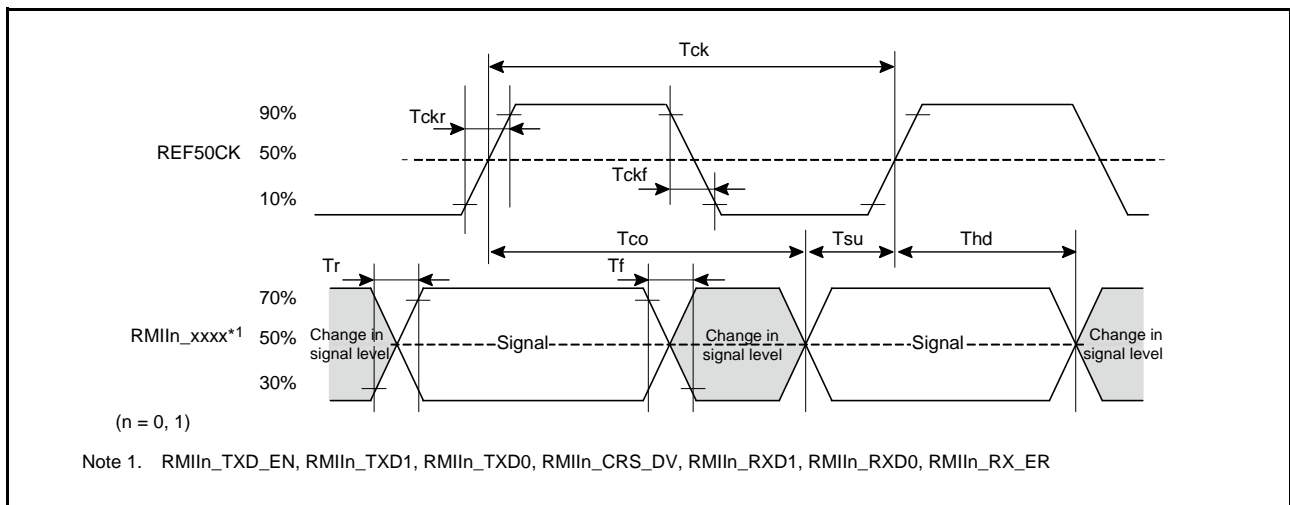

Figure 2.81 Timing with the REF50CK and RMII Signals

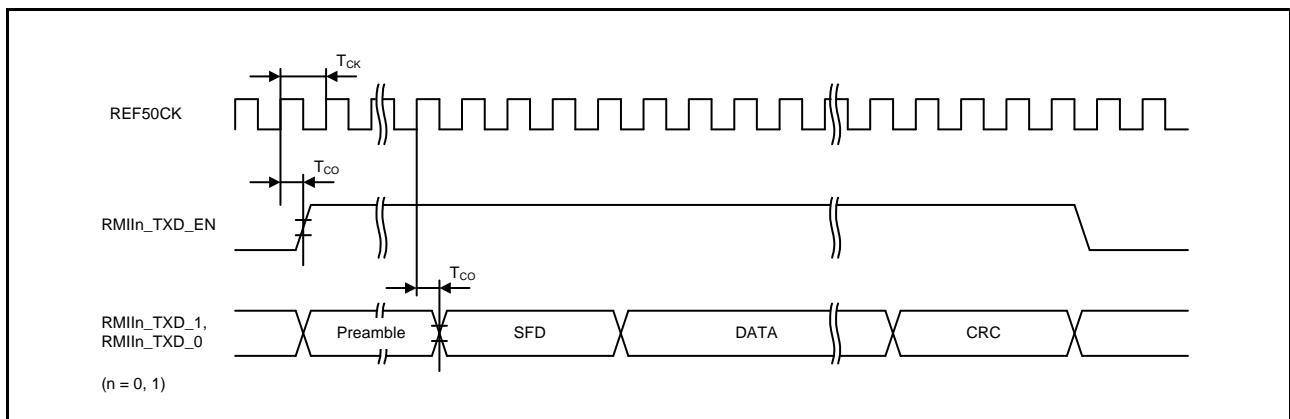

Figure 2.82 RMIITransmission Timing

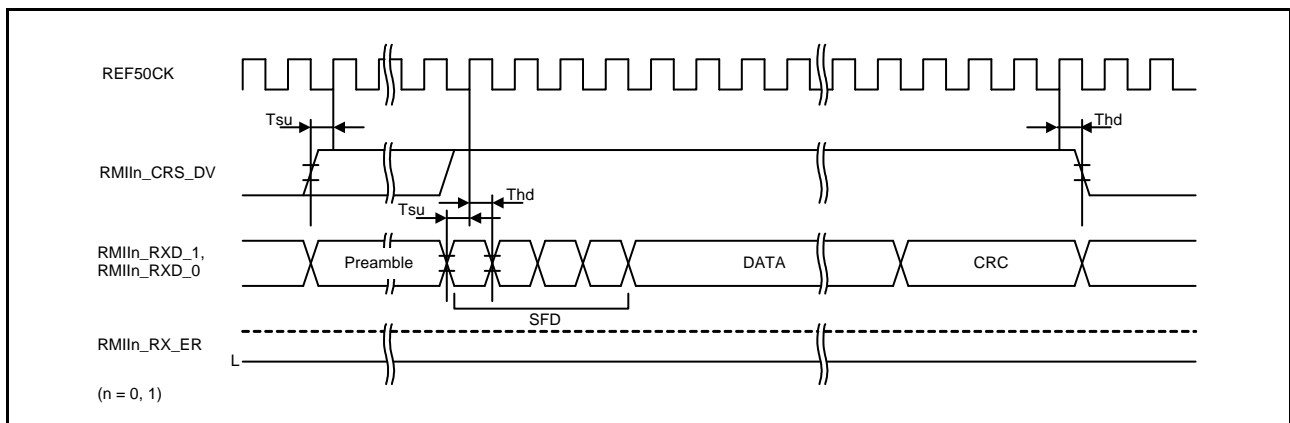

Figure 2.83 RMIITransmission Timing (Normal Operation)

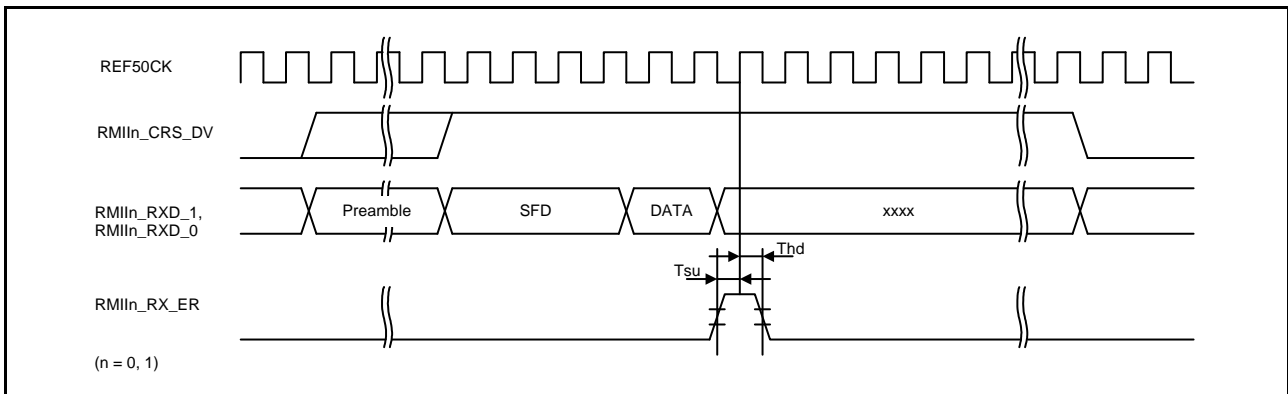

Figure 2.84 RMII Reception Timing (Error Occurrence)

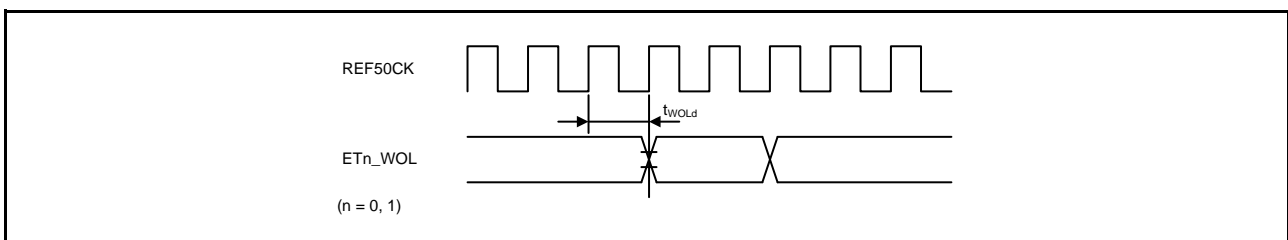

Figure 2.85 WOL Output Timing (RMII)

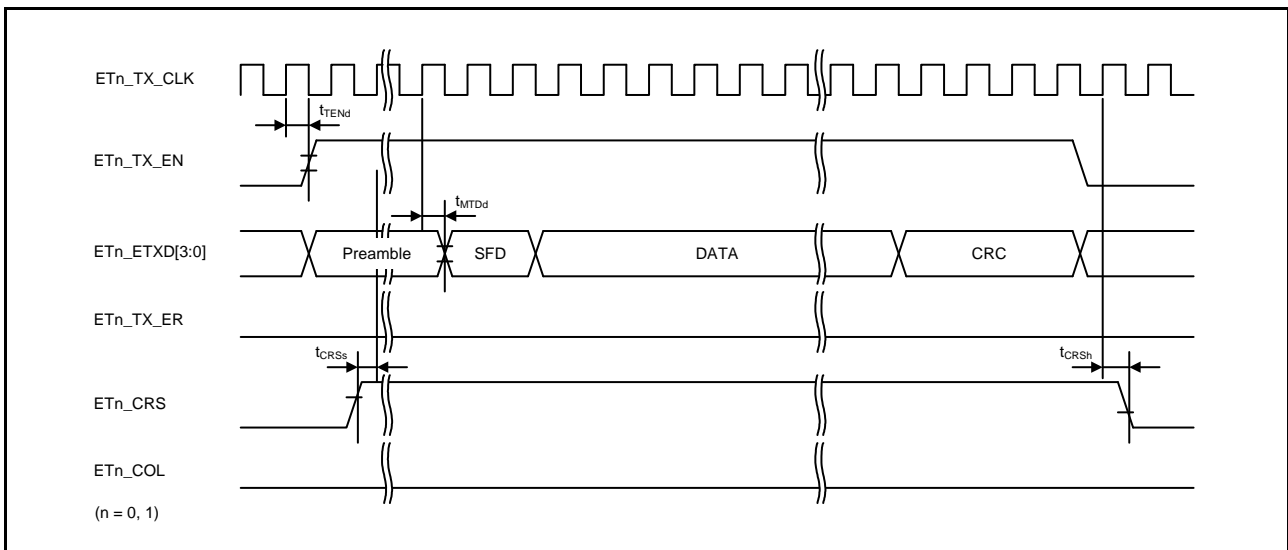

Figure 2.86 MII Transmission Timing (Normal Operation)

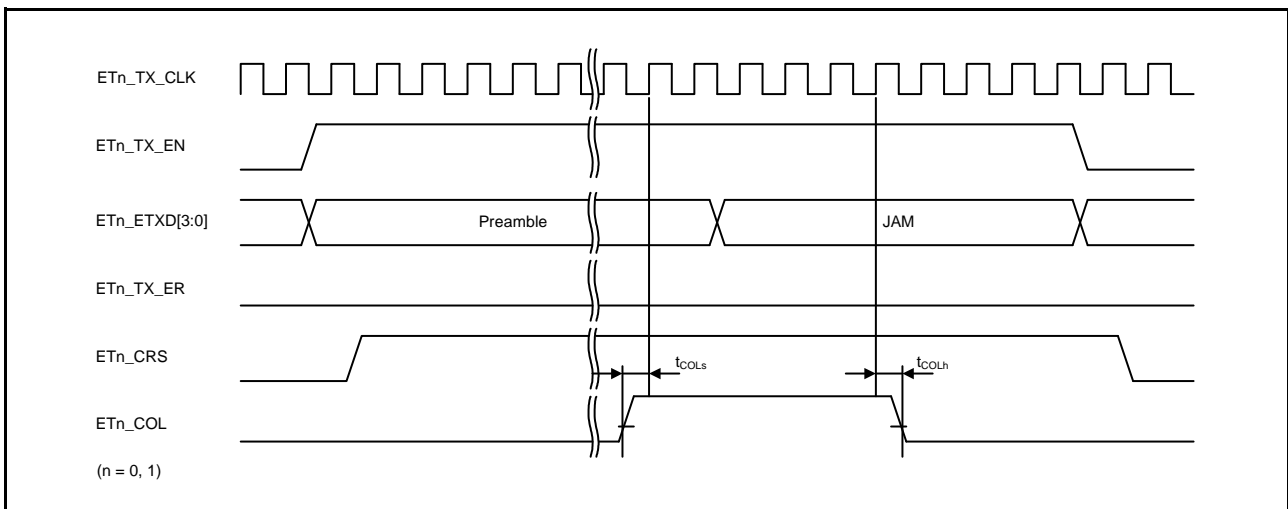

Figure 2.87 MII Transmission Timing (Conflict Occurrence)

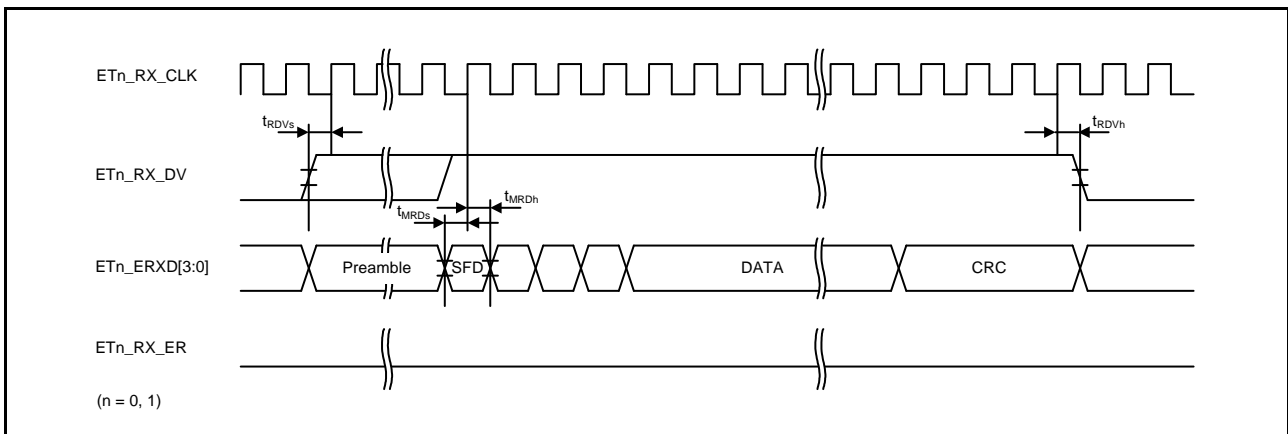

Figure 2.88 MII Reception Timing (Normal Operation)

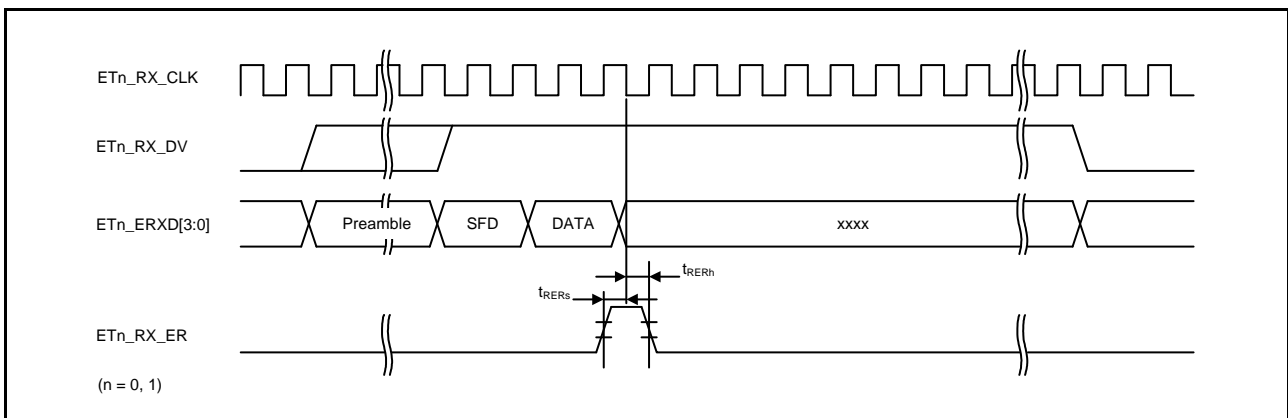

Figure 2.89 MII Reception Timing (Error Occurrence)

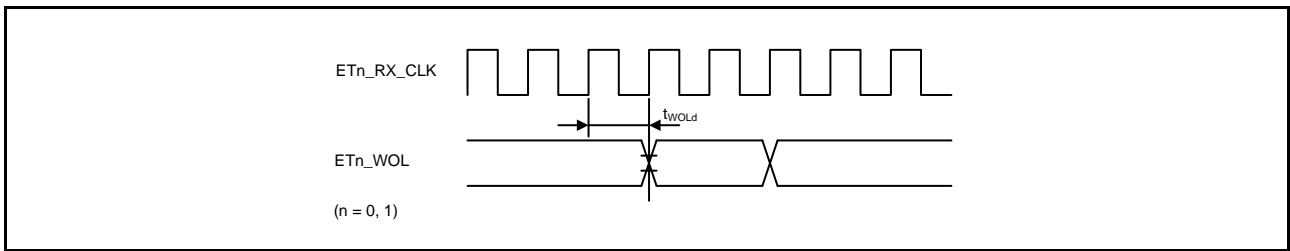

Figure 2.90 WOL Output Timing (MII)

2.4.7.18 PDC

Table 2.47 PDC Timing

Conditions: $V_{CC} = AVCC0 = AVCC1 = V_{CC_USB} = V_{BATT} = 2.7$ to 3.6 V, 2.7 V $\leq V_{REFH0} \leq AVCC0$,
 $V_{SS} = AVSS0 = AVSS1 = V_{REFL0} = V_{SS_USB} = 0$ V,
 $PCLKA = 8$ to 120 MHz, $PCLKB = 8$ to 60 MHz, $T_a = T_{opr}$,
 Output load conditions: $V_{OH} = 0.5 \times V_{CC}$, $V_{OL} = 0.5 \times V_{CC}$, $C = 30$ pF,
 High-drive output is selected by the driving ability control register.

Item	Symbol	Min.*1	Max.	Unit	Test Conditions	
PDC	PIXCLK input cycle time	t_{PIXcyc}	37	—	ns	Figure 2.91
	PIXCLK input high pulse width	t_{PIXH}	10	—	ns	
	PIXCLK input low pulse width	t_{PIXL}	10	—	ns	
	PIXCLK rising time	t_{PIXr}	—	5	ns	
	PIXCLK falling time	t_{PIXf}	—	5	ns	
PDC	PCKO output cycle time	t_{PCKcyc}	$2 \times t_{PBcyc}$	—	ns	Figure 2.92
	PCKO output high pulse width	t_{PCKH}	$(t_{PCKcyc} - t_{PCKr} - t_{PCKf})/2 - 3$	—	ns	
	PCKO output low pulse width	t_{PCKL}	$(t_{PCKcyc} - t_{PCKr} - t_{PCKf})/2 - 3$	—	ns	
	PCKO rising time	t_{PCKr}	—	5	ns	
	PCKO falling time	t_{PCKf}	—	5	ns	
PDC	VSYNC/HSYNC input setup time	t_{SYNCS}	10	—	ns	Figure 2.93
	VSYNC/HSYNC input hold time	t_{SYNCH}	5	—	ns	
	PIXD input setup time	t_{PIXDS}	10	—	ns	
	PIXD input hold time	t_{PIXDH}	5	—	ns	

Note 1. t_{PBcyc} : PCLKB cycle

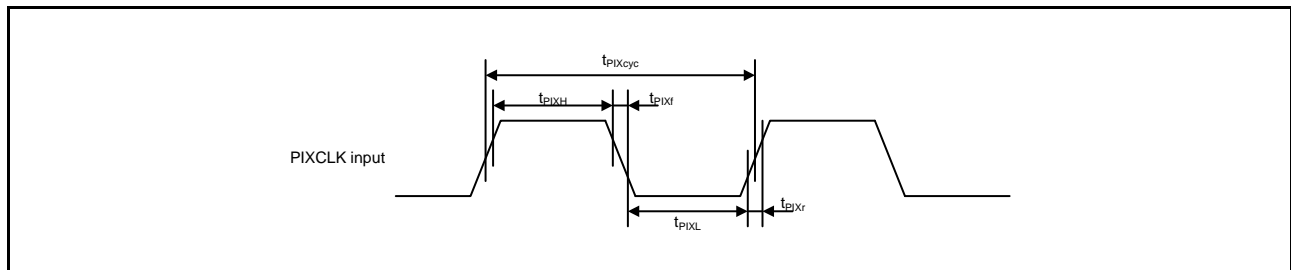

Figure 2.91 PDC Input Clock Timing

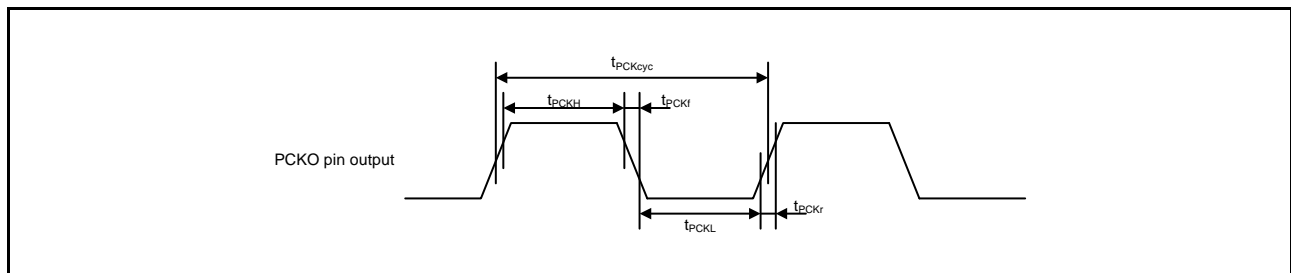

Figure 2.92 PDC Output Clock Timing

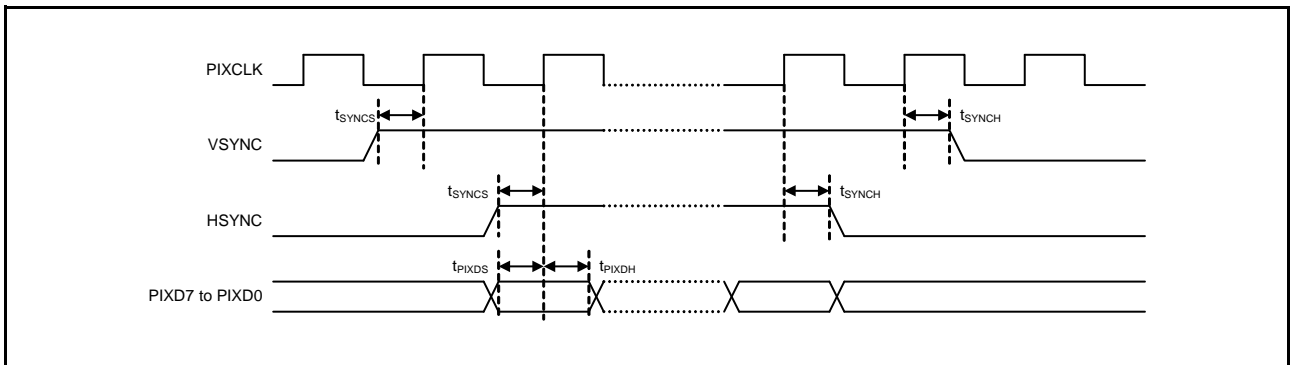

Figure 2.93 PDC AC Timing

2.4.7.19 GLCDC

Table 2.48 GLCDC Timing

Conditions: $V_{CC} = AV_{CC0} = AV_{CC1} = V_{CC_USB} = V_{BATT} = 2.7$ to 3.6 V, 2.7 V $\leq V_{REFH0} \leq AV_{CC0}$,
 $V_{SS} = AV_{SS0} = AV_{SS1} = V_{REFL0} = V_{SS_USB} = 0$ V,
 $PCLKA = 8$ to 120 MHz, $PCLKB = 8$ to 60 MHz, $T_a = T_{opr}$,
 Output load conditions: $V_{OH} = 0.5 \times V_{CC}$, $V_{OL} = 0.5 \times V_{CC}$, $C = 30$ pF

Item	Symbol	Min.	Typ.	Max.	Unit	Test Conditions
LCD_EXTCLK Input clock frequency	$t_{E_{cyc}}$	—	—	30*1	MHz	Figure 2.94
LCD_EXTCLK Input clock Low pulse width	t_{WL}	0.45	—	0.55	$t_{E_{cyc}}$	
LCD_EXTCLK Input clock High pulse width	t_{WH}	0.45	—	0.55	$t_{E_{cyc}}$	
LCD_CLK Output clock frequency	$t_{L_{cyc}}$	—	—	30*1	MHz	Figure 2.95
LCD_CLK Output clock Low pulse width	t_{LOL}	0.4	—	0.6	$t_{L_{cyc}}$	
LCD_CLK Output clock High pulse width	t_{LOH}	0.4	—	0.6	$t_{L_{cyc}}$	
LCD_CLK Output clock rise time	t_{LOR}	—	—	5	ns	
LCD_CLK Output clock fall time	t_{LOF}	—	—	5	ns	
LCD data output Delay timing	t_{DD}	-3.5^{*2}	—	4^{*2}	ns	Figure 2.96

Note 1. Parallel RGB888,666,565: Max. 27 MHz
 Serial RGB888: Max. 30 MHz (4x speed)

Note 2. We recommend using pins that have a letter (“-A”, “-B”, etc) to indicate group membership appended to their names as groups. For the GLCDC interface, the AC portion of the electrical characteristics is measured for each group. If we use group “-A” and “-B” combination, “LCD data output Delay timing (t_{DD})” is Min = -5.0 ns, Max = 5.5 ns.

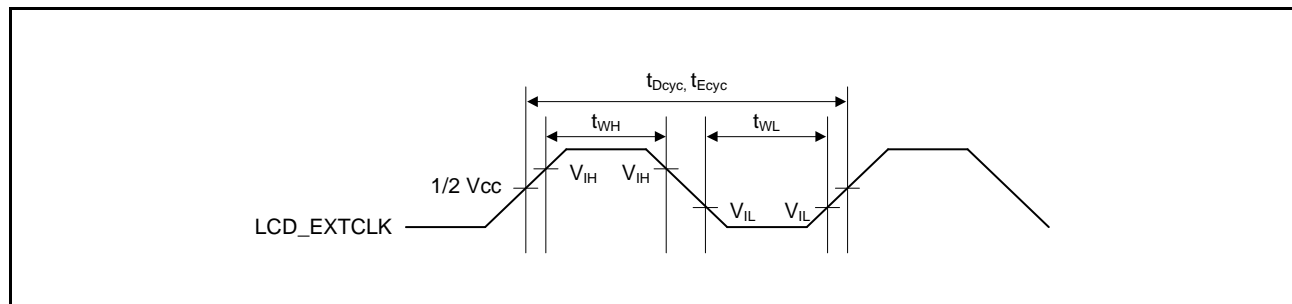
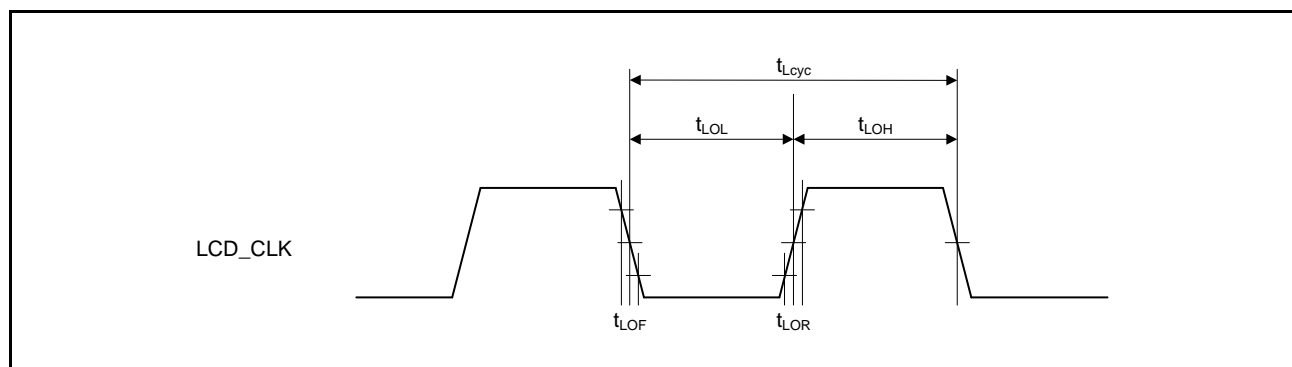
**Figure 2.94 LCD_EXTCLK Clock Input Timing****Figure 2.95 LCD_CLK Clock Output Timing**

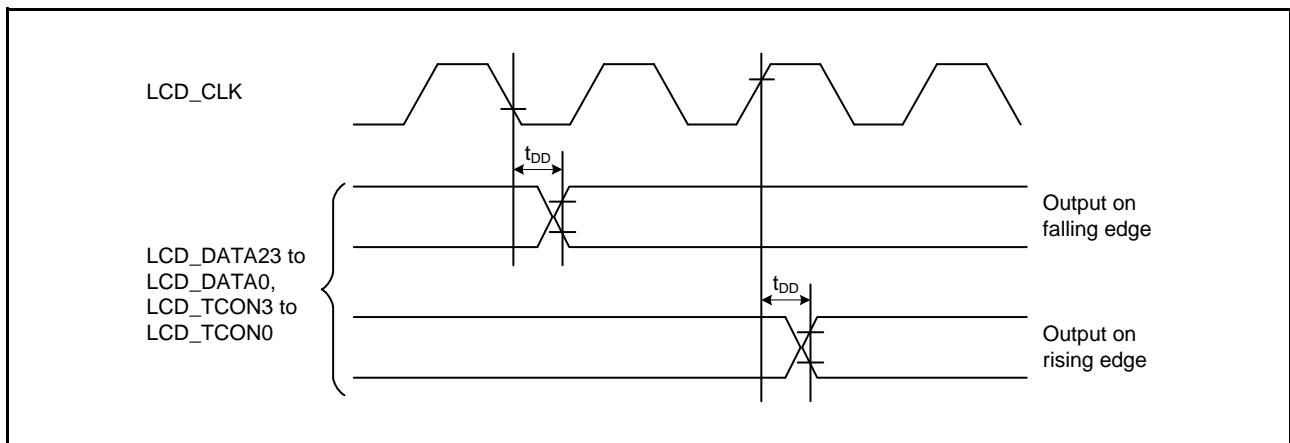

Figure 2.96 LCD Output Data Timing

2.4.7.20 A/D Converter Trigger

Table 2.49 A/D Converter Trigger Timing

Conditions: $V_{CC} = AVCC0 = AVCC1 = VCC_USB = V_{BATT} = 2.7$ to 3.6 V, 2.7 V $\leq VREFH0 \leq AVCC0$,
 $VSS = AVSS0 = AVSS1 = VREFL0 = VSS_USB = 0$ V,
 $PCLKA = 8$ to 120 MHz, $PCLKB = 8$ to 60 MHz, $T_a = T_{opr}$,
 Output load conditions: $V_{OH} = 0.5 \times VCC$, $V_{OL} = 0.5 \times VCC$, $C = 30$ pF,
 High-drive output is selected by the driving ability control register.

Item		Symbol	Min.	Max.	Unit*1	Test Conditions
A/D converter	A/D converter trigger input pulse width	t_{TRGW}	1.5	—	t_{PBcyc}	Figure 2.97

Note 1. t_{PBcyc} : PCLKB cycle

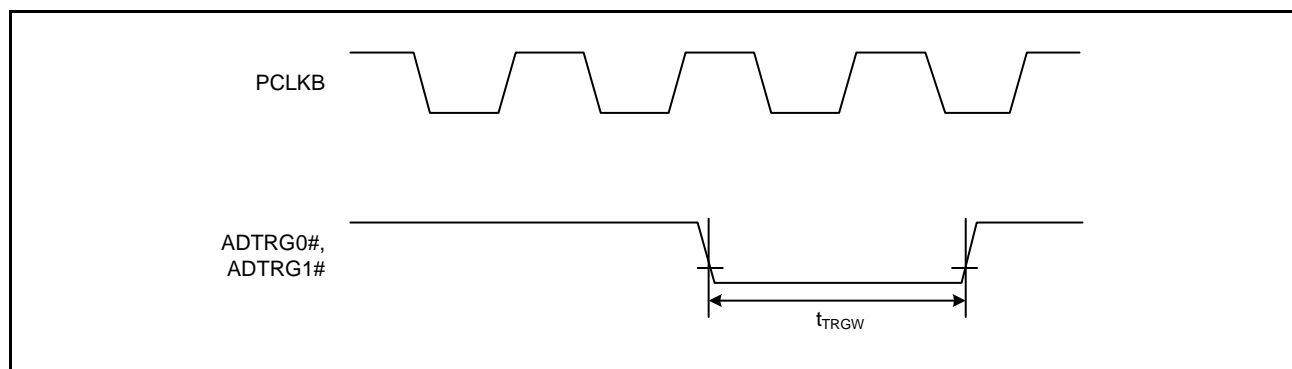
**Figure 2.97 A/D Converter Trigger Input Timing**

2.4.7.21 CAC

Table 2.50 CAC Timing

Conditions: $VCC = AVCC0 = AVCC1 = VCC_USB = V_{BATT} = 2.7$ to 3.6 V, 2.7 V \leq $VREFH0 \leq AVCC0$,
 $VSS = AVSS0 = AVSS1 = VREFL0 = VSS_USB = 0$ V,
 $PCLKA = 8$ to 120 MHz, $PCLKB = 8$ to 60 MHz, $T_a = T_{opr}$,
 Output load conditions: $V_{OH} = 0.5 \times VCC$, $V_{OL} = 0.5 \times VCC$, $C = 30$ pF,
 High-drive output is selected by the driving ability control register.

Item*1, *2		Symbol	Min.*1, *2	Max.	Unit	Test Conditions
CAC	CACREF input pulse width	$t_{PBcyc} \leq t_{cac}$	t_{CACREF}	$4.5 t_{cac} + 3 t_{PBcyc}$	—	ns
		$t_{PBcyc} > t_{cac}$		$5 t_{cac} + 6.5 t_{PBcyc}$	—	

Note 1. t_{PBcyc} : PCLKB cycle

Note 2. t_{cac} : CAC count clock source cycle

2.5 USB Characteristics

Table 2.51 On-Chip USB Low Speed (Host Only) Characteristics (DP and DM Pin Characteristics)

Conditions: $V_{CC} = AV_{CC0} = AV_{CC1} = V_{CC_USB} = V_{BATT} = 3.0$ to 3.6 V, 3.0 V $\leq V_{REFH0} \leq AV_{CC0}$,
 $V_{SS} = AV_{SS0} = AV_{SS1} = V_{REFL0} = V_{SS_USB} = 0$ V,
 $U_{CLK} = 48$ MHz, $P_{CLKA} = 8$ to 120 MHz,
 $P_{CLKB} = 8$ to 60 MHz, $T_a = T_{opr}$

Item	Symbol	Min.	Typ.	Max.	Unit	Test Conditions	
Input characteristics	Input high level voltage	V_{IH}	2.0	—	—	V	
	Input low level voltage	V_{IL}	—	—	0.8	V	
	Differential input sensitivity	V_{DI}	0.2	—	—	V	DP – DM
	Differential common mode range	V_{CM}	0.8	—	2.5	V	
Output characteristics	Output high level voltage	V_{OH}	2.8	—	3.6	V	$I_{OH} = -200$ μ A
	Output low level voltage	V_{OL}	0.0	—	0.3	V	$I_{OL} = 2$ mA
	Cross-over voltage	V_{CRS}	1.3	—	2.0	V	Figure 2.98
	Rise time	t_{LR}	75	—	300	ns	
	Fall time	t_{LF}	75	—	300	ns	
	Rise/fall time ratio	t_{LR} / t_{LF}	80	—	125	%	t_{LR} / t_{LF}
Pull-down characteristics	DP/DM pull-down resistance (when the host controller function is selected)	R_{pdr}	14.25	—	24.80	k Ω	

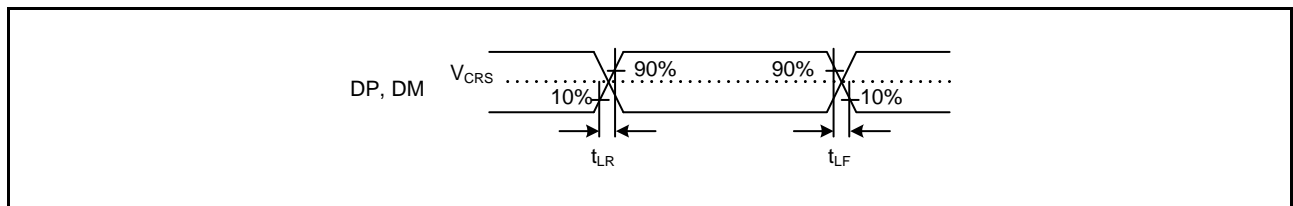

Figure 2.98 DP and DM Output Timing (Low Speed)

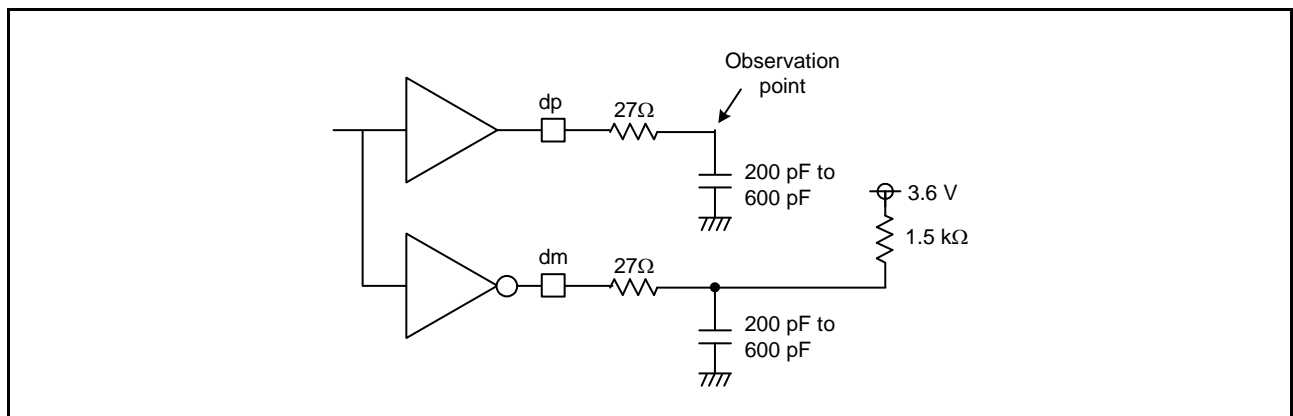

Figure 2.99 Test Circuit (Low Speed)

Table 2.52 On-Chip USB Full-Speed Characteristics (DP and DM Pin Characteristics)

Conditions: $V_{CC} = AV_{CC0} = AV_{CC1} = V_{CC_USB} = V_{BATT} = 3.0$ to 3.6 V, 3.0 V $\leq V_{REFH0} \leq AV_{CC0}$,
 $V_{SS} = AV_{SS0} = AV_{SS1} = V_{REFL0} = V_{SS_USB} = 0$ V,
 $U_{CLK} = 48$ MHz, $P_{CLKA} = 8$ to 120 MHz,
 $P_{CLKB} = 8$ to 60 MHz, $T_a = T_{opr}$

Item		Symbol	Min.	Typ.	Max.	Unit	Test Conditions
Input characteristics	Input high level voltage	V_{IH}	2.0	—	—	V	
	Input low level voltage	V_{IL}	—	—	0.8	V	
	Differential input sensitivity	V_{DI}	0.2	—	—	V	DP – DM
	Differential common mode range	V_{CM}	0.8	—	2.5	V	
Output characteristics	Output high level voltage	V_{OH}	2.8	—	3.6	V	$I_{OH} = -200 \mu A$
	Output low level voltage	V_{OL}	0.0	—	0.3	V	$I_{OL} = 2$ mA
	Cross-over voltage	V_{CRS}	1.3	—	2.0	V	Figure 2.100
	Rise time	t_{FR}	4	—	20	ns	
	Fall time	t_{FF}	4	—	20	ns	
	Rise/fall time ratio	t_{FR} / t_{FF}	90	—	111.11	%	t_{FR} / t_{FF}
	Output resistance	Z_{DRV}	28	—	44	Ω	$R_s = 27 \Omega$ included
Pull-up and pull-down characteristics	DP pull-up resistance (when the function controller function is selected)	R_{pu}	0.900	—	1.575	k Ω	Idle state
			1.425	—	3.090	k Ω	At transmission and reception
	DP/DM pull-down resistance (when the host controller function is selected)	R_{pd}	14.25	—	24.80	k Ω	

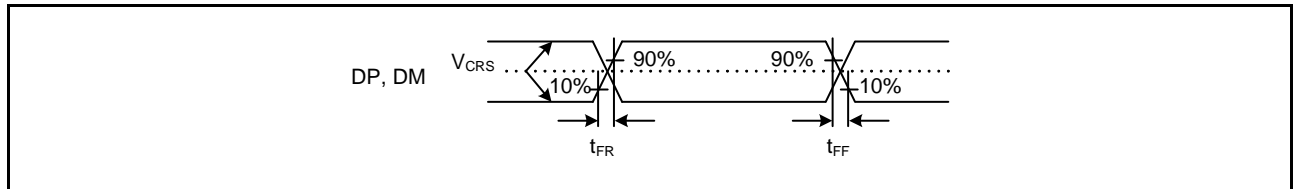

Figure 2.100 DP and DM Output Timing (Full-Speed)

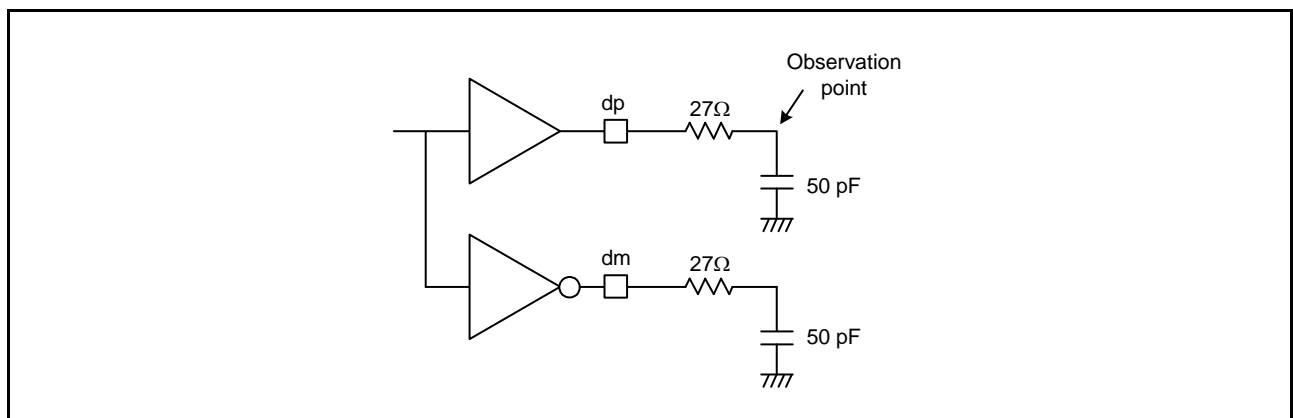

Figure 2.101 Test Circuit (Full-Speed)

2.6 A/D Conversion Characteristics

Table 2.53 12-Bit A/D (Unit 0) Conversion Characteristics

Conditions: $V_{CC} = AVCC0 = AVCC1 = V_{CC_USB} = V_{BATT} = 2.7$ to 3.6 V, 2.7 V $\leq V_{REFH0} \leq AVCC0$,
 $V_{SS} = AVSS0 = AVSS1 = V_{REFL0} = V_{SS_USB} = 0$ V,
 $PCLKB = PCLKC = 1$ MHz to 60 MHz, $T_a = T_{opr}$, Source impedance = 1.0 k Ω

Item	Min.	Typ.	Max.	Unit	Test Conditions	
Resolution	8	—	12	Bit		
Analog input capacitance	—	—	30	pF		
Channel-dedicated sample-and-hold circuits in use (AN000 to AN002)	Conversion time*1 (Operation at PCLKC = 60 MHz)	1.06 (0.4 + 0.25) *2	—	—	μ s	<ul style="list-style-type: none"> Sampling of channel-dedicated sample-and-hold circuits in 24 states Sampling in 15 states
	Offset error	—	± 1.5	± 3.5	LSB	AN000 to AN002 = 0.25 V
	Full-scale error	—	± 1.5	± 3.5	LSB	AN000 to AN002 = $V_{REFH0} - 0.25$ V
	Quantization error	—	± 0.5	—	LSB	
	Absolute accuracy	—	± 3.0	± 5.5	LSB	
	DNL differential nonlinearity error	—	± 1.0	± 2.0	LSB	
	INL integral nonlinearity error	—	± 1.5	± 3.0	LSB	
	Holding characteristics of sample-and-hold circuits	—	—	20	μ s	
Dynamic range	0.25	—	$V_{REFH0} - 0.25$	V		
Channel-dedicated sample-and-hold circuits not in use (AN000 to AN007)	Conversion time*1 (Operation at PCLKC = 60 MHz)	0.48 (0.267)*2	—	—	μ s	Sampling in 16 states
	Offset error	—	± 1.0	± 2.5	LSB	
	Full-scale error	—	± 1.0	± 2.5	LSB	
	Quantization error	—	± 0.5	—	LSB	
	Absolute accuracy	—	± 2.5	± 4.5	LSB	
	DNL differential nonlinearity error	—	± 0.5	± 1.5	LSB	
INL integral nonlinearity error	—	± 1.0	± 2.5	LSB		

Note: The above specification values apply when there is no access to the external bus during A/D conversion. If access proceeds during A/D conversion, values may not fall within the above ranges.

Note 1. The conversion time includes the sampling time and the comparison time. As the test conditions, the number of sampling states is indicated.

Note 2. The value in parentheses indicates the sampling time.

Table 2.54 12-Bit A/D (Unit 1) Conversion Characteristics

Conditions: $V_{CC} = AVCC0 = AVCC1 = V_{CC_USB} = V_{BATT} = 2.7$ to 3.6 V, 2.7 V $\leq V_{REFH0} \leq AVCC0$,
 $V_{SS} = AVSS0 = AVSS1 = V_{REFL0} = V_{SS_USB} = 0$ V,
 $PCLKB = PCLKD = 1$ MHz to 60 MHz, $T_a = T_{opr}$, Source impedance = 1.0 k Ω

Item	Min.	Typ.	Max.	Unit	Test Conditions
Resolution	8	—	12	Bit	
Conversion time*1 (Operation at PCLKD = 60 MHz)	0.88 (0.633)*2	—	—	μ s	Sampling in 38 states (ADSAM.SAM = 1)
Conversion time*1 (Operation at PCLKD = 30 MHz)	1 (0.500)*2	—	—	μ s	Sampling in 15 states (ADSAM.SAM = 1)
Analog input capacitance	—	—	30	pF	
Offset error	—	± 2.0	± 3.5	LSB	
Full-scale error	—	± 2.0	± 3.5	LSB	
Quantization error	—	± 0.5	—	LSB	
Absolute accuracy	—	± 4.0	± 6.0	LSB	
DNL differential nonlinearity error (Operation at PCLKD = 60 MHz)	—	± 1.5	± 4.0	LSB	
DNL differential nonlinearity error (Operation at PCLKD = 30 MHz)	—	± 1.5	± 2.5	LSB	
INL integral nonlinearity error (Operation at PCLKD = 60 MHz)	—	± 2.0	± 4.0	LSB	
INL integral nonlinearity error (Operation at PCLKD = 30 MHz)	—	± 2.0	± 3.5	LSB	

Note: The above specification values apply when there is no access to the external bus during A/D conversion. If access proceeds during A/D conversion, values may not fall within the above ranges.

Note 1. The conversion time includes the sampling time and the comparison time. As the test conditions, the number of sampling states is indicated.

Note 2. The value in parentheses indicates the sampling time.

Table 2.55 A/D Internal Reference Voltage Characteristics

Conditions: $V_{CC} = AVCC0 = AVCC1 = V_{CC_USB} = V_{BATT} = 2.7$ to 3.6 V, 2.7 V $\leq V_{REFH0} \leq AVCC0$,
 $V_{SS} = AVSS0 = AVSS1 = V_{REFL0} = V_{SS_USB} = 0$ V,
 $PCLKB = PCLKD = 60$ MHz, $T_a = T_{opr}$

Item	Min.	Typ.	Max.	Unit	Test Conditions
A/D internal reference voltage	1.13	1.18	1.23	V	

2.7 D/A Conversion Characteristics

Table 2.56 D/A Conversion Characteristics

Conditions: $V_{CC} = AVCC0 = AVCC1 = V_{CC_USB} = V_{BATT} = 2.7$ to 3.6 V, 2.7 V $\leq V_{REFH0} \leq AVCC0$,
 $V_{SS} = AVSS0 = AVSS1 = V_{REFL0} = V_{SS_USB} = 0$ V,
 $T_a = T_{opr}$

Item		Symbol	Min.	Typ.	Max.	Unit	Test Conditions
Resolution		—	12	12	12	Bit	
Unbuffered output	Absolute accuracy	—	—	—	± 6.0	LSB	2-M Ω resistive load 10-bit conversion
	Differential nonlinearity error	DNL	—	± 1.0	± 2.0	LSB	2-M Ω resistive load
	Output resistance	R_O	—	8.6	—	k Ω	
	Setting time	t_S	—	—	3	μ s	20-pF capacitive load
Buffered output	Load resistance	R_L	5	—	—	k Ω	
	Load capacitance	C_L	—	—	50	pF	
	Output voltage	V_O	0.2	—	$AVCC1 - 0.2$	V	
	Differential nonlinearity error	DNL	—	± 1.0	± 2.0	LSB	
	Integral nonlinearity error	INL	—	± 2.0	± 4.0	LSB	
	Setting time	t_S	—	—	4	μ s	

2.8 Temperature Sensor Characteristics

Table 2.57 Temperature Sensor Characteristics

Conditions: $V_{CC} = AVCC0 = AVCC1 = V_{CC_USB} = V_{BATT} = 2.7$ to 3.6 V, 2.7 V $\leq V_{REFH0} \leq AVCC0$,
 $V_{SS} = AVSS0 = AVSS1 = V_{REFL0} = V_{SS_USB} = 0$ V,
 $T_a = T_{opr}$

Item	Min.	Typ.	Max.	Unit	Test Conditions
Relative accuracy	—	± 1	—	$^{\circ}$ C	
Temperature slope	—	4	—	mV/ $^{\circ}$ C	
Output voltage	—	1.21	—	V	$T_a = 25^{\circ}$ C
Temperature sensor start time	—	—	30	μ s	
Sampling time*1	4.15	—	—	μ s	

Note 1. Set the S12AD1.ADSSTRT register such that the sampling time of the 12-bit A/D converter satisfies this specification.

2.9 Power-on Reset Circuit and Voltage Detection Circuit Characteristics

Table 2.58 Power-on Reset Circuit and Voltage Detection Circuit Characteristics

Conditions: $V_{CC} = AV_{CC0} = AV_{CC1} = V_{CC_USB} = V_{BATT} = 2.7$ to 3.6 V, 2.7 V $\leq V_{REFH0} \leq AV_{CC0}$,
 $V_{SS} = AV_{SS0} = AV_{SS1} = V_{REFL0} = V_{SS_USB} = 0$ V,
 $T_a = T_{opr}$

Item		Symbol	Min.	Typ.	Max.	Unit	Test Conditions	
Voltage detection level	Power-on reset (POR)	Low power consumption function disabled*1	V_{POR}	2.5	2.6	2.7	V	Figure 2.102
		Low power consumption function enabled*2		1.8	2.25	2.7		
	Voltage detection circuit (LVD0)		V_{det0_1}	2.84	2.94	3.04		Figure 2.103
			V_{det0_2}	2.77	2.87	2.97		
			V_{det0_3}	2.70	2.80	2.90		
	Voltage detection circuit (LVD1)		V_{det1_1}	2.89	2.99	3.09		Figure 2.104
			V_{det1_2}	2.82	2.92	3.02		
			V_{det1_3}	2.75	2.85	2.95		
	Voltage detection circuit (LVD2)		V_{det2_1}	2.89	2.99	3.09		Figure 2.105
			V_{det2_2}	2.82	2.92	3.02		
			V_{det2_3}	2.75	2.85	2.95		
	Internal reset time	Power-on reset time	t_{POR}	—	4.6	—		ms
LVD0 reset time		t_{LVD0}	—	0.70	—	Figure 2.103		
LVD1 reset time		t_{LVD1}	—	0.57	—	Figure 2.104		
LVD2 reset time		t_{LVD2}	—	0.57	—	Figure 2.105		
Minimum VCC down time		t_{VOFF}	200	—	—	μ s	Figure 2.102, Figure 2.103	
Response delay time		t_{det}	—	—	200	μ s	Figure 2.102 to Figure 2.105	
LVD operation stabilization time (after LVD is enabled)		$t_{d(E-A)}$	—	—	10	μ s	Figure 2.104, Figure 2.105	
Hysteresis width (LVD1 and LVD2)		V_{LVH}	—	70	—	mV		

Note: The minimum VCC down time indicates the time when VCC is below the minimum value of voltage detection levels V_{POR} , V_{det1} , and V_{det2} for the POR/ LVD.

Note 1. The low power consumption function is disabled and DEEPCUT[1:0] = 00b or 01b.

Note 2. The low power consumption function is enabled and DEEPCUT[1:0] = 11b.

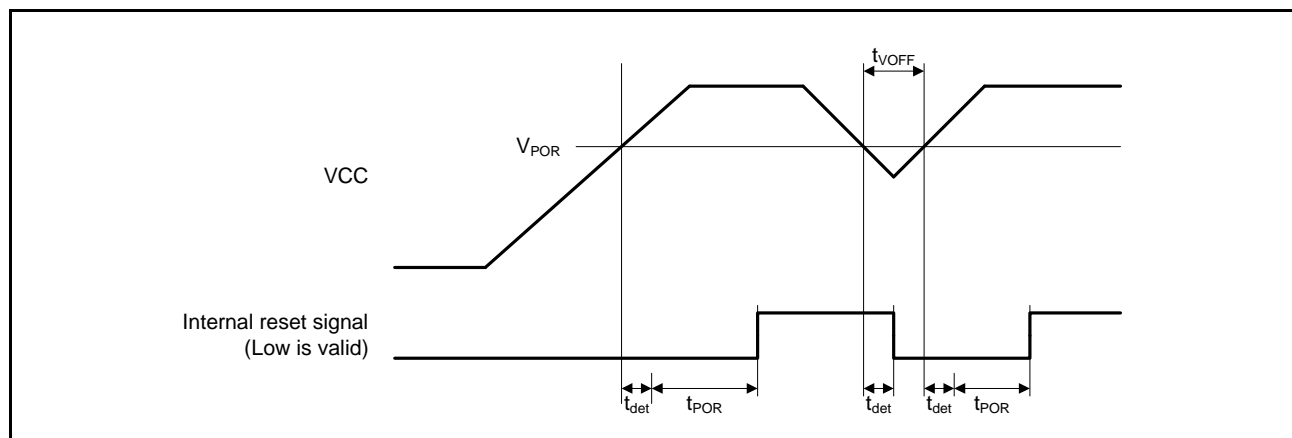
**Figure 2.102 Power-on Reset Timing**

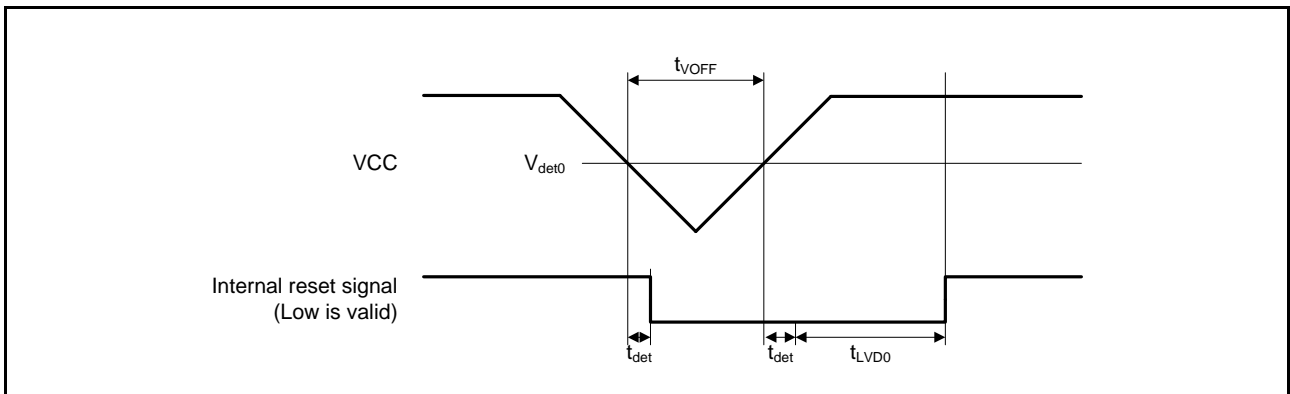

Figure 2.103 Voltage Detection Circuit Timing (V_{det0})

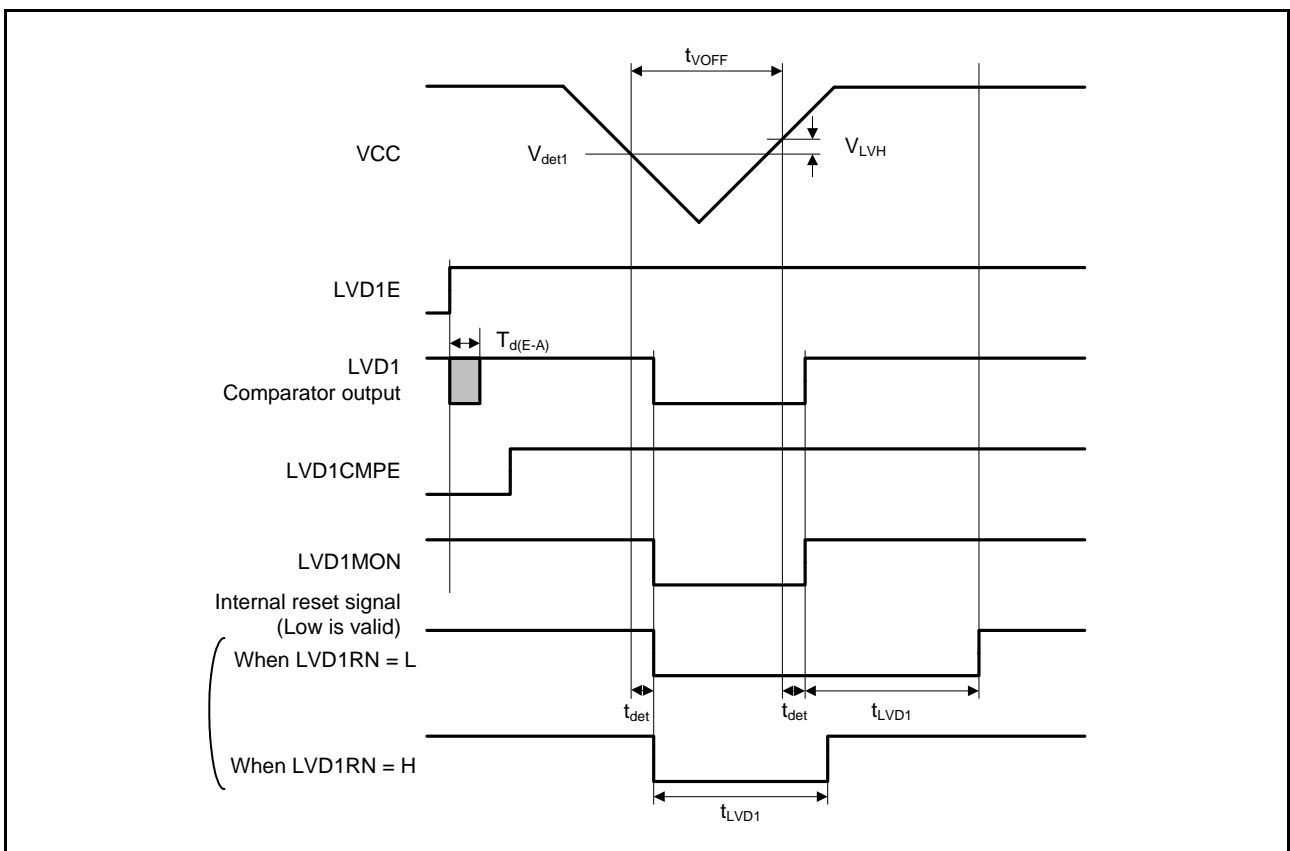

Figure 2.104 Voltage Detection Circuit Timing (V_{det1})

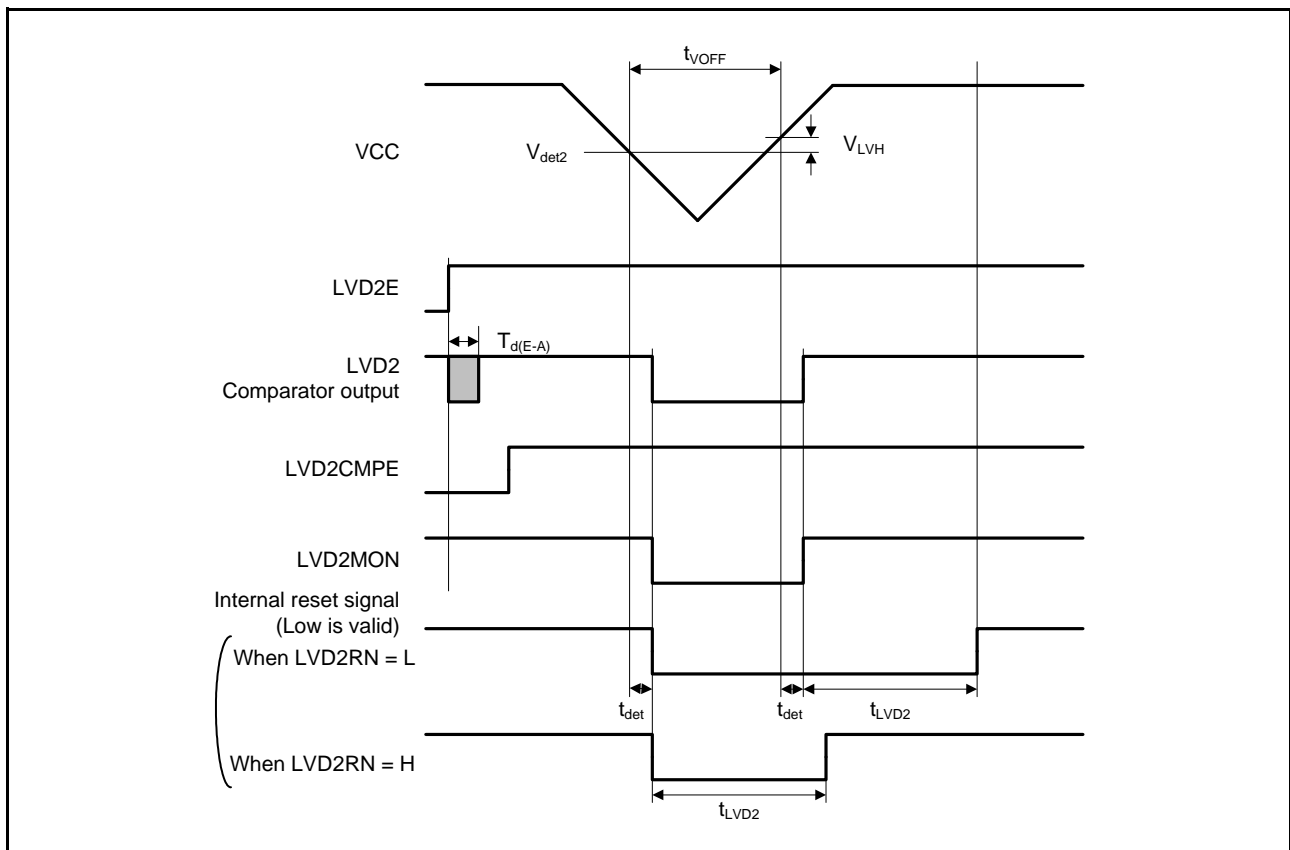

Figure 2.105 Voltage Detection Circuit Timing (V_{det2})

2.10 Oscillation Stop Detection Timing

Table 2.59 Oscillation Stop Detection Circuit Characteristics

Conditions: $VCC = AVCC0 = AVCC1 = VCC_USB = V_{BATT} = 2.7$ to 3.6 V, 2.7 V $\leq VREFH0 \leq AVCC0$,
 $VSS = AVSS0 = AVSS1 = VREFL0 = VSS_USB = 0$ V,
 $T_a = T_{opr}$

Item	Symbol	Min.	Typ.	Max.	Unit	Test Conditions
Detection time	t_{dr}	—	—	1	ms	Figure 2.106

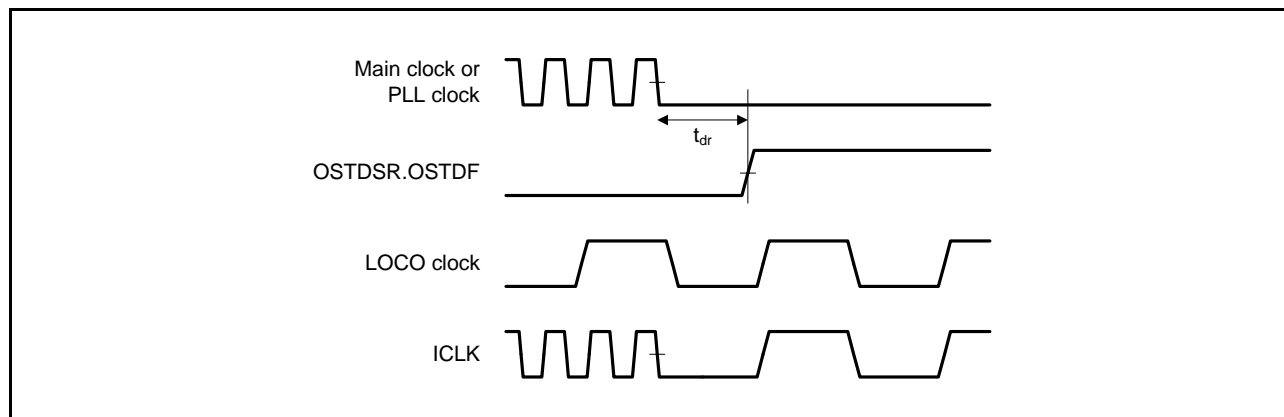

Figure 2.106 Oscillation Stop Detection Timing

2.11 Battery Backup Function Characteristics

Table 2.60 Battery Backup Function Characteristics

Conditions: $V_{CC} = AV_{CC0} = AV_{CC1} = V_{CC_USB} = 2.7$ to 3.6 V, 2.7 V $\leq V_{REFH0} \leq AV_{CC0}$,
 $V_{SS} = AV_{SS0} = AV_{SS1} = V_{REFL0} = V_{SS_USB} = 0$ V,
 $V_{BATT} = 2.0$ to 3.6 V, $T_a = T_{opr}$

Item	Symbol	Min.	Typ.	Max.	Unit	Test Conditions
Voltage level for switching to battery backup	$V_{DETBATT}$	2.50	2.60	2.70	V	Figure 2.107
Lower-limit V_{BATT} voltage for power supply switching due to VCC voltage drop	V_{BATTSW}	2.70	—	—		
VCC-off period for starting power supply switching	$t_{VOFFBATT}$	200	—	—	μ s	

Note: The VCC-off period for starting power supply switching indicates the period in which VCC is below the minimum value of the voltage level for switching to battery backup ($V_{DETBATT}$).

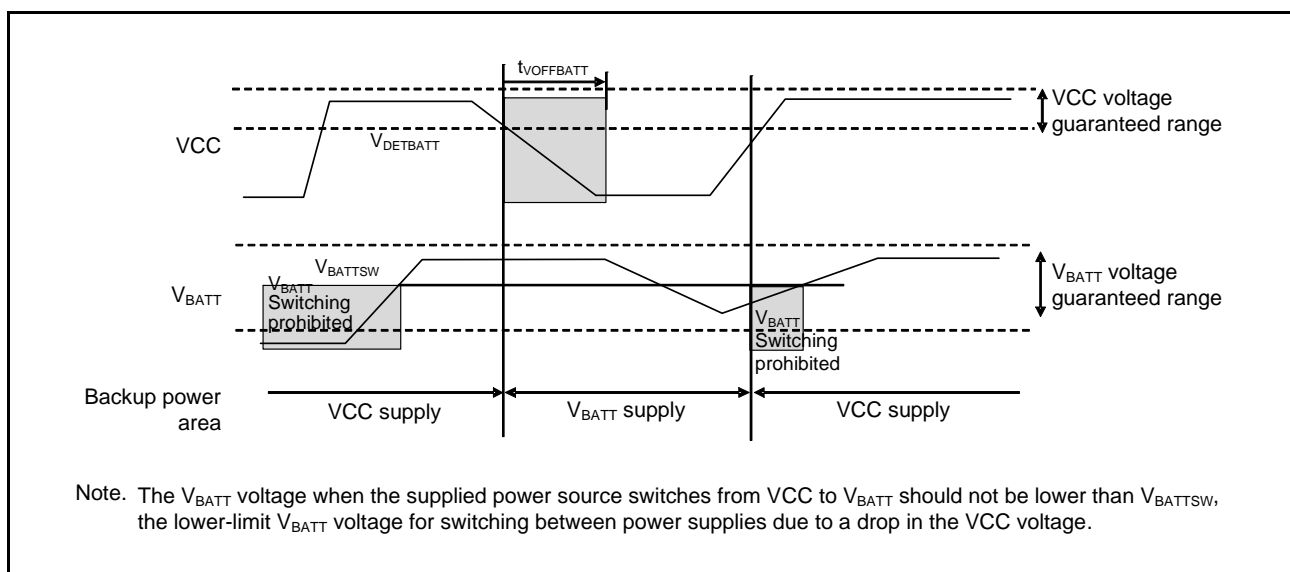

Figure 2.107 Battery Backup Function Characteristics

2.12 Flash Memory Characteristics

Table 2.61 Code Flash Memory Characteristics

Conditions: $V_{CC} = AVCC0 = AVCC1 = V_{CC_USB} = V_{BATT} = 2.7$ to 3.6 V, 2.7 V $\leq V_{REFH0} \leq AVCC0$,
 $V_{SS} = AVSS0 = AVSS1 = V_{REFL0} = V_{SS_USB} = 0$ V,
 Temperature range for programming/erasure: $T_a = T_{opr}$

Item	Symbol	FCLK = 4 MHz			FCLK = 15 MHz			20 MHz \leq FCLK \leq 60 MHz			Unit	
		Min.	Typ.	Max.	Min.	Typ.	Max.	Min.	Typ.	Max.		
Programming time $N_{PEC} \leq 100$ times	128 bytes	t_{P128}	—	0.75	13.2	—	0.38	6.6	—	0.34	6	ms
	8 Kbytes	t_{P8K}	—	49	176	—	25	88	—	22	80	ms
	32 Kbytes	t_{P32K}	—	194	704	—	97	352	—	88	320	ms
Programming time $N_{PEC} > 100$ times	128 bytes	t_{P128}	—	0.91	15.8	—	0.46	8	—	0.41	7.2	ms
	8 Kbytes	t_{P8K}	—	60	212	—	30	106	—	27	96	ms
	32 Kbytes	t_{P32K}	—	234	848	—	117	424	—	106	384	ms
Erasure time $N_{PEC} \leq 100$ times	8 Kbytes	t_{E8K}	—	78	216	—	48	132	—	43	120	ms
	32 Kbytes	t_{E32K}	—	283	864	—	173	528	—	157	480	ms
Erasure time $N_{PEC} > 100$ times	8 Kbytes	t_{E8K}	—	94	260	—	58	158	—	52	144	ms
	32 Kbytes	t_{E32K}	—	341	1040	—	208	632	—	189	576	ms
Reprogramming/erasure cycle*1	N_{PEC}	10000 *2	—	—	10000 *2	—	—	10000 *2	—	—	—	Times
Suspend delay time during programming	t_{SPD}	—	—	264	—	—	132	—	—	120	—	μ s
First suspend delay time during erasing (in suspend priority mode)	t_{SESD1}	—	—	216	—	—	132	—	—	120	—	μ s
Second suspend delay time during erasure (in suspend priority mode)	t_{SESD2}	—	—	1.7	—	—	1.7	—	—	1.7	—	ms
Suspend delay time during erasure (in erasure priority mode)	t_{SEED}	—	—	1.7	—	—	1.7	—	—	1.7	—	ms
Forced stop command	t_{FD}	—	—	32	—	—	22	—	—	20	—	μ s
Data hold time*3	t_{DRP}	10	—	—	10	—	—	10	—	—	—	Year

Note 1. Definition of reprogram/erase cycle:

The program/erase cycle is the number of erasing for each block. When the number of program/erase cycles is n , each block can be erased n times. For instance, when 128-byte program is performed 64 times for different addresses in 8-Kbyte block and then the block is erased, the program/erase cycle is counted as one. However, the same address cannot be programmed more than once before the next erase cycle (overwriting is prohibited).

Note 2. Characteristics are degraded as the number of program/erase increases. This is the minimum value of program/erase cycles to guarantee all characteristics listed in this table.

Note 3. This shows the characteristics when the program/erase cycle does not exceed the specified value.

Table 2.62 Data Flash Memory Characteristics

Conditions: $V_{CC} = AVCC0 = AVCC1 = V_{CC_USB} = V_{BATT} = 2.7$ to 3.6 V, 2.7 V $\leq V_{REFH0} \leq AVCC0$,
 $V_{SS} = AVSS0 = AVSS1 = V_{REFL0} = V_{SS_USB} = 0$ V,
 Temperature range for programming/erasure: $T_a = T_{opr}$

Item	Symbol	FCLK = 4 MHz			FCLK = 15 MHz			20 MHz \leq FCLK \leq 60 MHz			Unit	
		Min.	Typ.	Max.	Min.	Typ.	Max.	Min.	Typ.	Max.		
Programming time	4 bytes	t_{DP4}	—	0.36	3.8	—	0.18	1.9	—	0.16	1.7	ms
Erasure time	64 bytes	t_{DP64}	—	3.1	18	—	1.9	11	—	1.7	10	ms
	128 bytes	t_{DP128}	—	4.7	27	—	2.9	16	—	2.6	15	ms
	256 bytes	t_{DP256}	—	8.9	50	—	5.4	31	—	4.9	28	ms
Blank check time	4 bytes	t_{DBC4}	—	—	84	—	—	33	—	—	30	μ s
	64 bytes	t_{DBC64}	—	—	280	—	—	110	—	—	100	μ s
	2 Kbytes	t_{DBC2K}	—	—	6160	—	—	2420	—	—	2200	μ s
Reprogramming/erasure cycle*1	N_{DPEC}	100000 *2	—	—	100000 *2	—	—	100000 *2	—	—	—	Times
Suspend delay time during programming	t_{DSPD}	—	—	264	—	—	132	—	—	120	μ s	
First suspend delay time during erasure (in suspend priority mode)	64 bytes	—	—	—	216	—	—	132	—	—	120	μ s
	128 bytes	—	—	—	216	—	—	132	—	—	120	μ s
	256 bytes	—	—	—	216	—	—	132	—	—	120	μ s
Second suspend delay time during erasure (in suspend priority mode)	64 bytes	—	—	—	300	—	—	300	—	—	300	μ s
	128 bytes	—	—	—	390	—	—	390	—	—	390	μ s
	256 bytes	—	—	—	570	—	—	570	—	—	570	μ s
Suspend delay time during erasing (in suspend priority mode)	64 bytes	—	—	—	300	—	—	300	—	—	300	μ s
	128 bytes	—	—	—	390	—	—	390	—	—	390	μ s
	256 bytes	—	—	—	570	—	—	570	—	—	570	μ s
Forced stop command	t_{FD}	—	—	32	—	—	22	—	—	20	μ s	
Data hold time*3	t_{DDRP}	10	—	—	10	—	—	10	—	—	Year	

Note 1. Definition of reprogram/erase cycle:

The program/erase cycle is the number of erasing for each block. When the number of program/erase cycles is n , each block can be erased n times. For instance, when 4-byte program is performed 512 times for different addresses in 2-Kbyte block and then the block is erased, the program/erase cycle is counted as one. However, the same address cannot be programmed more than once before the next erase cycle (overwriting is prohibited).

Note 2. Characteristics are degraded as the number of program/erase increases. This is the minimum value of program/erase cycles to guarantee all characteristics listed in this table.

Note 3. This shows the characteristics when the program/erase cycle does not exceed the specified value.

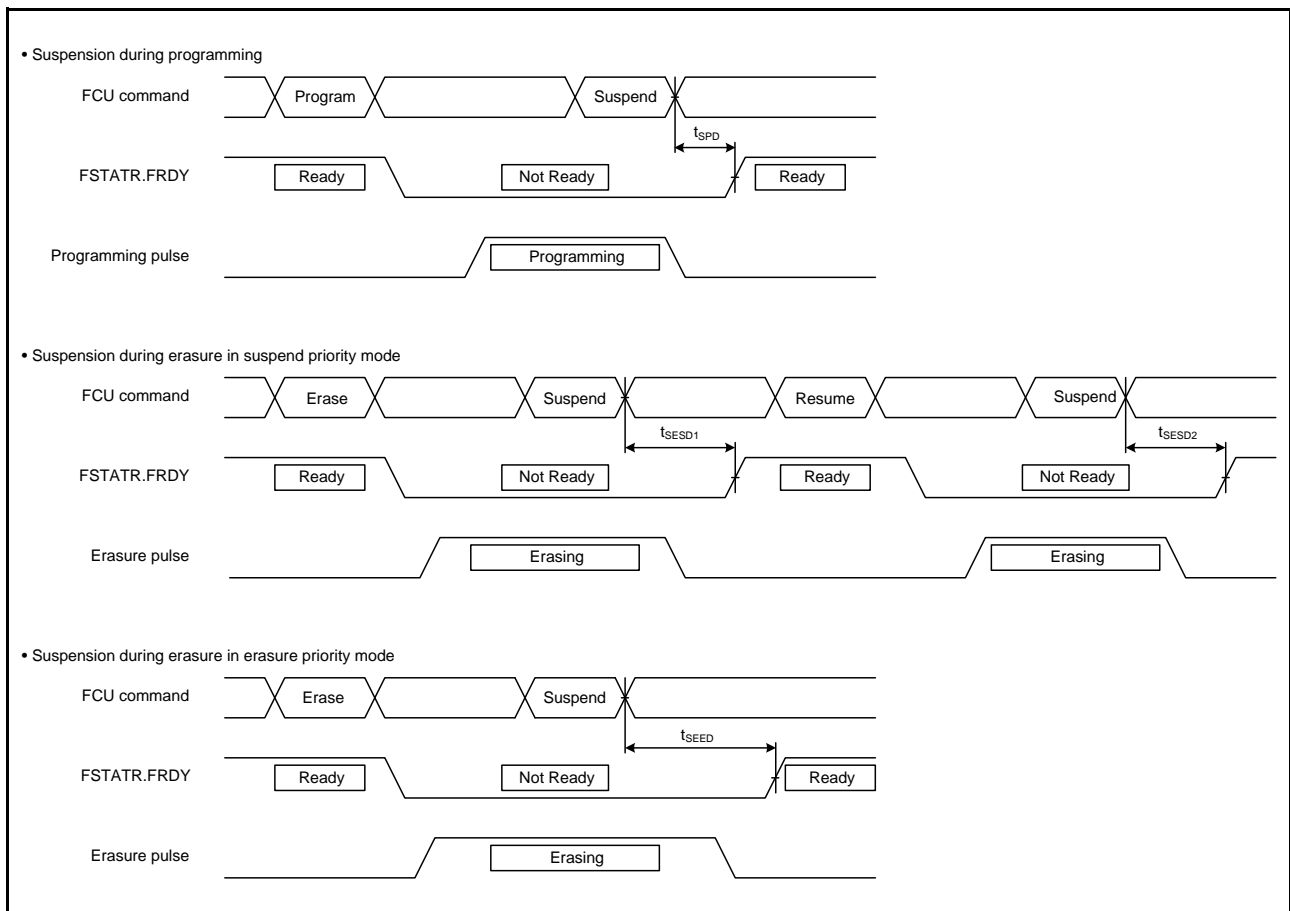

Figure 2.108 Flash Memory Programming/Erasure Suspension Timing

2.13 Boundary Scan

Table 2.63 Boundary Scan Characteristics

Conditions: $V_{CC} = AVCC0 = AVCC1 = VCC_USB = V_{BATT} = 2.7$ to 3.6 V, 2.7 V \leq $V_{REFH0} \leq AVCC0$,
 $V_{SS} = AVSS0 = AVSS1 = V_{REFL0} = VSS_USB = 0$ V,
 $T_a = T_{opr}$,
 Output load conditions: $V_{OH} = 0.5 \times V_{CC}$, $V_{OL} = 0.5 \times V_{CC}$, $C = 30$ pF,
 High-drive output is selected by the driving ability control register.

Item	Symbol	Min.	Typ.	Max.	Unit	Test Conditions
TCK clock cycle time	t_{TCKcyc}	100	—	—	ns	Figure 2.109
TCK clock high pulse width	t_{TCKH}	45	—	—	ns	
TCK clock low pulse width	t_{TCKL}	45	—	—	ns	
TCK clock rise time	t_{TCKr}	—	—	5	ns	
TCK clock fall time	t_{TCKf}	—	—	5	ns	
TRST# pulse width	t_{TRSTW}	20	—	—	t_{TCKcyc}	Figure 2.110
TMS setup time	t_{TMSS}	20	—	—	ns	Figure 2.111
TMS hold time	t_{TMSH}	20	—	—	ns	
TDI setup time	t_{TDIS}	20	—	—	ns	
TDI hold time	t_{TDIH}	20	—	—	ns	
TDO data delay time	t_{TDOD}	—	—	40	ns	

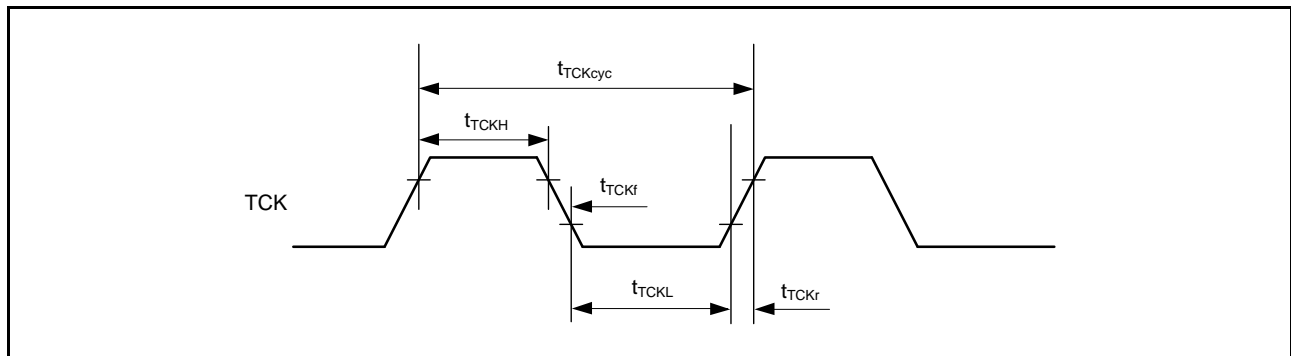

Figure 2.109 Boundary Scan TCK Timing

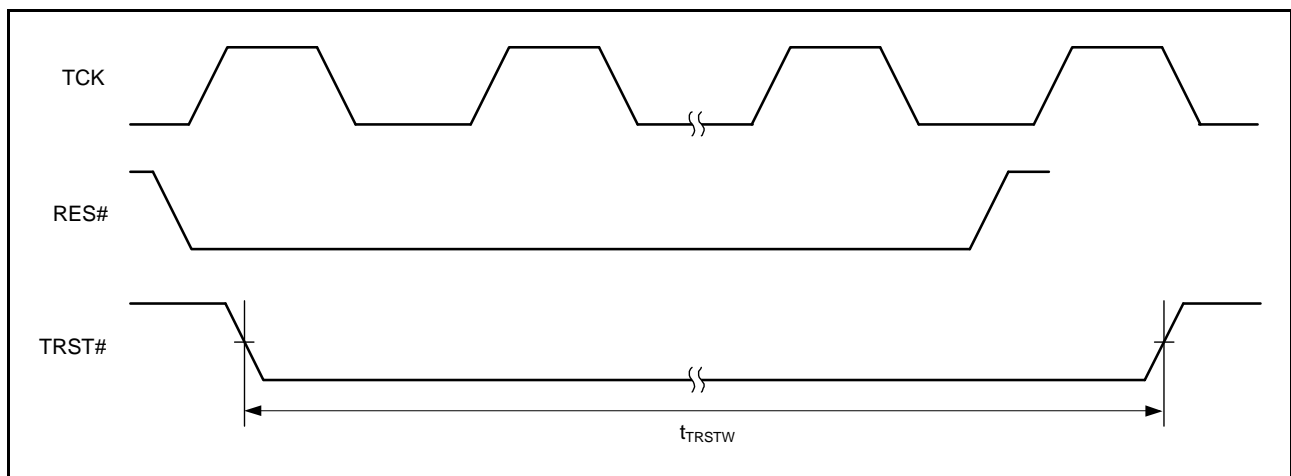

Figure 2.110 Boundary Scan TRST# Timing

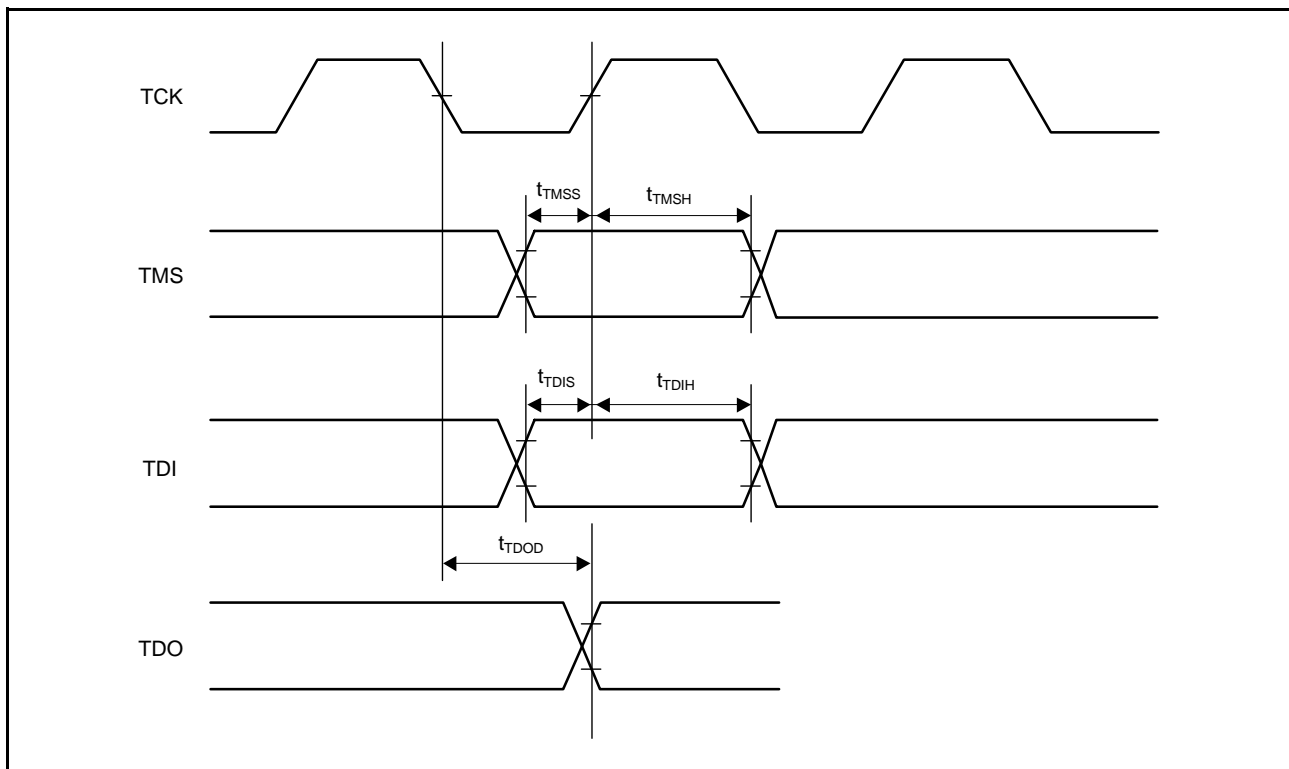

Figure 2.111 Boundary Scan Input/Output Timing

Appendix 1. Package Dimensions

Information on the latest version of the package dimensions or mountings has been displayed in “Packages” on Renesas Electronics Corporation website.

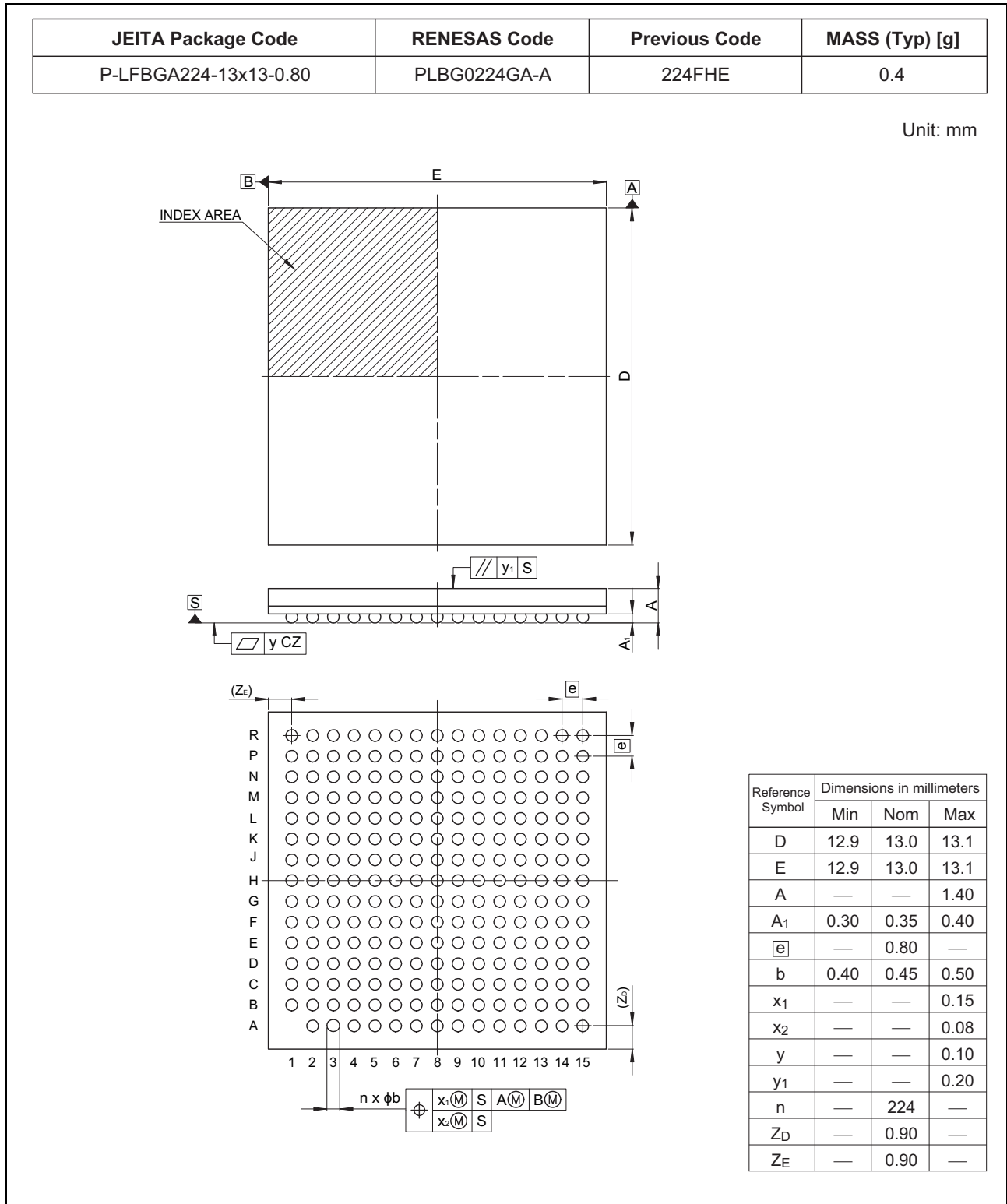

Figure A 224-Pin LFBGA (PLBG0224GA-A)

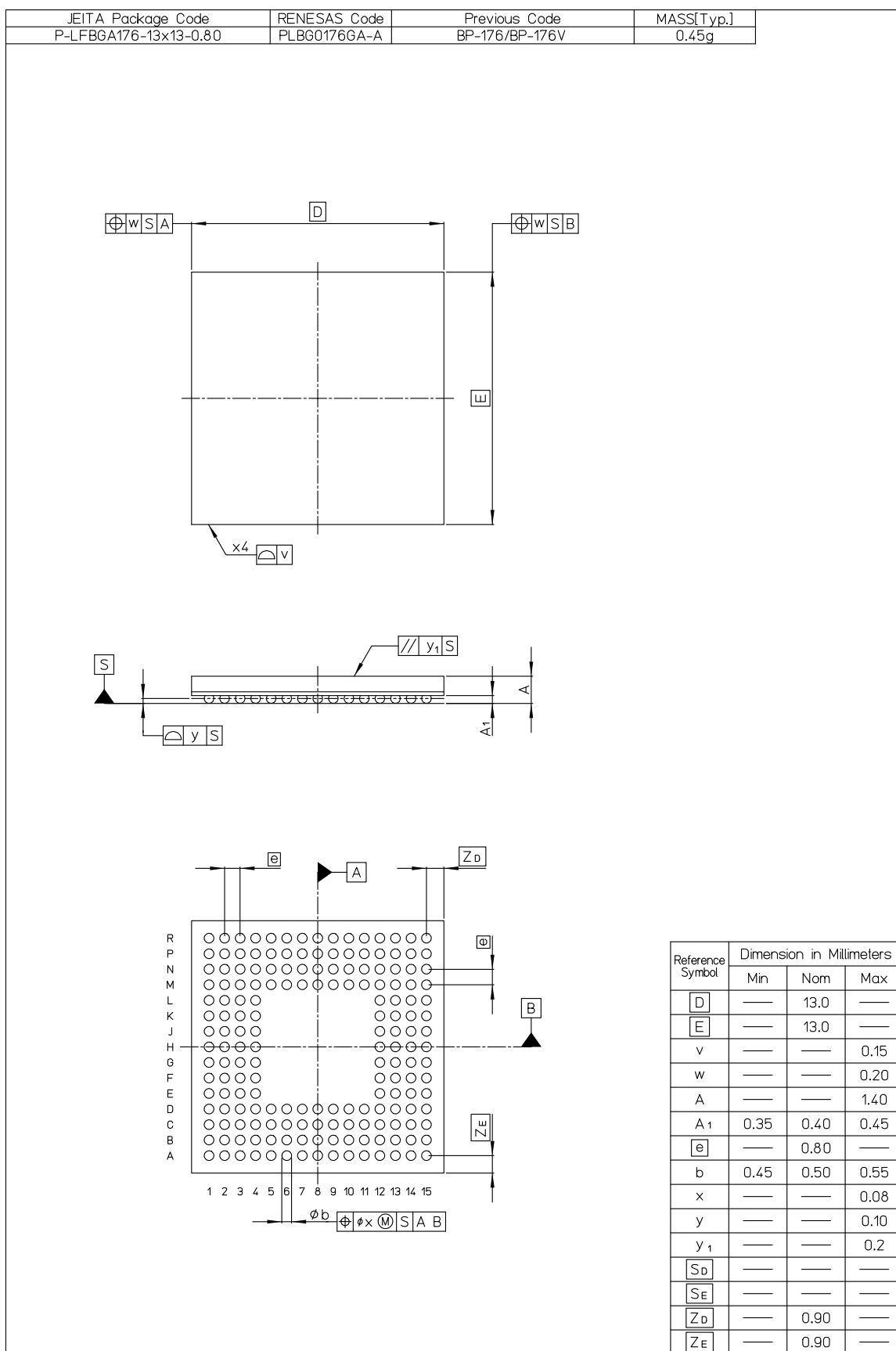

Figure B 176-Pin LFBGA (PLBG0176GA-A)

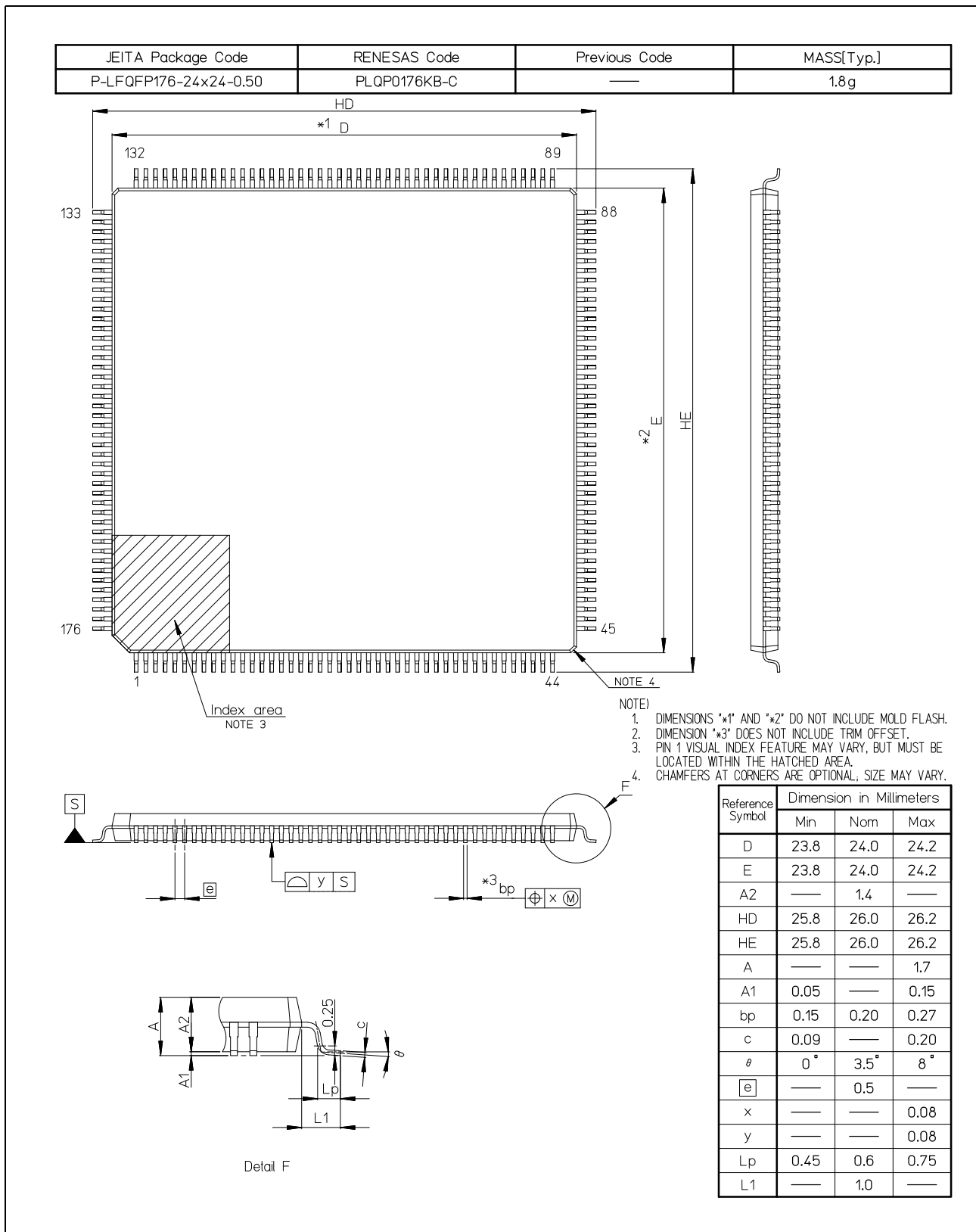

Figure C 176-Pin LFQFP (PLQP0176KB-C)

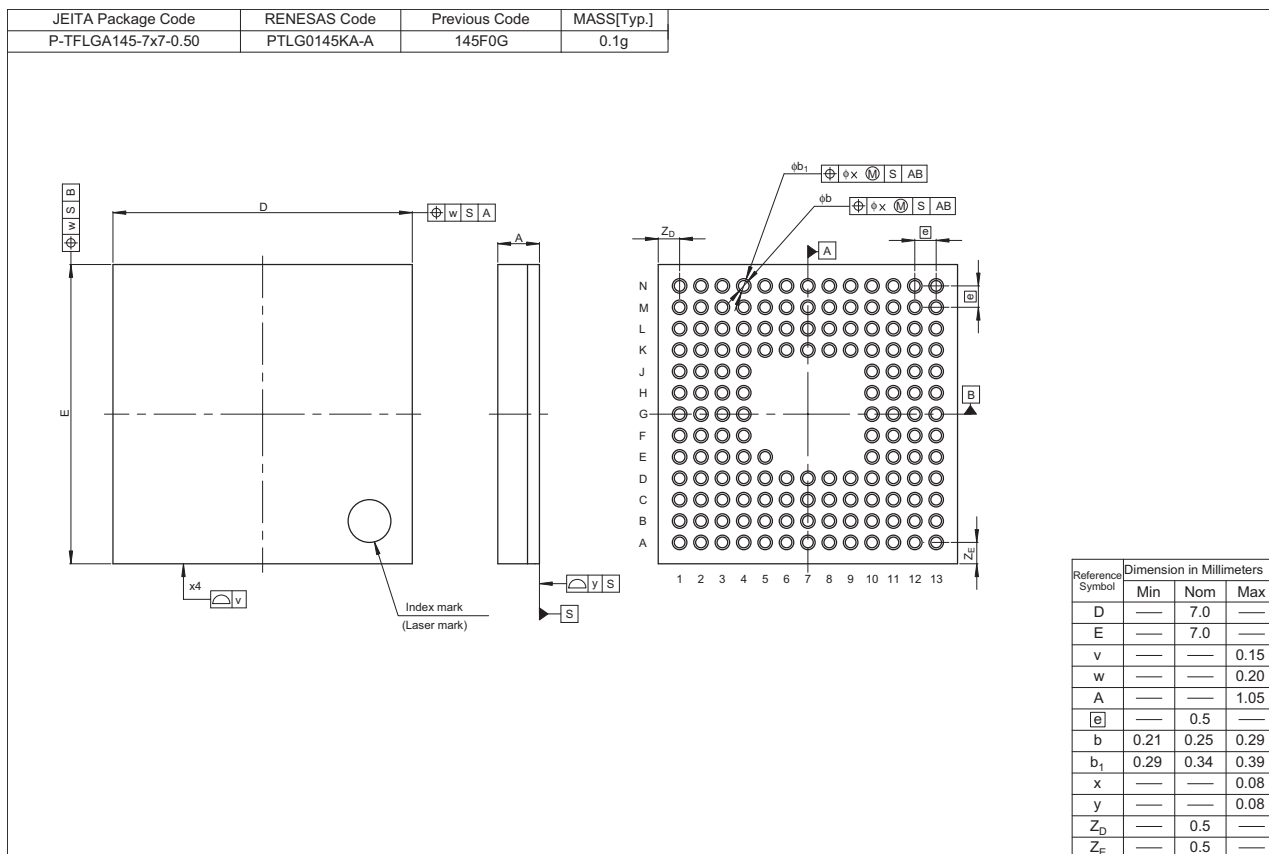
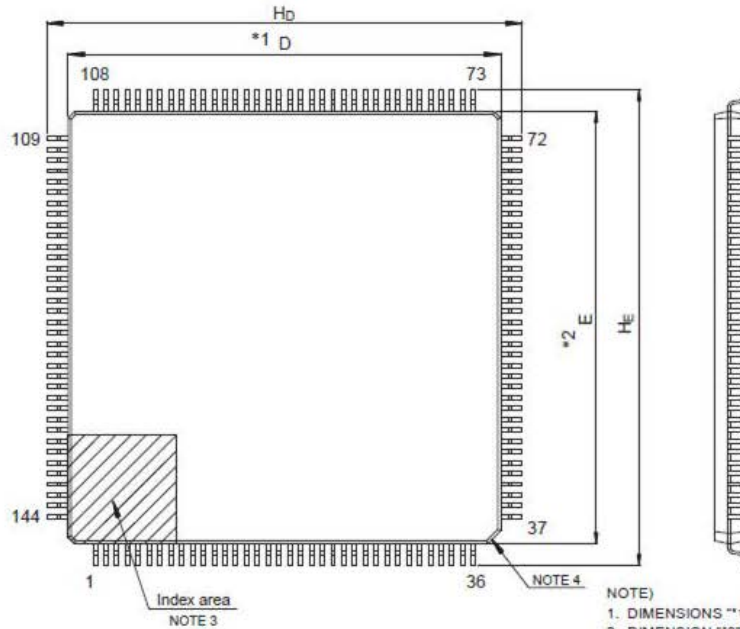

Figure D 145-Pin TFLGA (PTLG0145KA-A)

JEITA Package Code	RENESAS Code	Previous Code	MASS (Typ) [g]
P-LFQFP144-20x20-0.50	PLQP0144KA-B	—	1.2

Unit: mm



- NOTE)
1. DIMENSIONS "1" AND "2" DO NOT INCLUDE MOLD FLASH.
 2. DIMENSION "3" DOES NOT INCLUDE TRIM OFFSET.
 3. PIN 1 VISUAL INDEX FEATURE MAY VARY, BUT MUST BE LOCATED WITHIN THE HATCHED AREA.
 4. CHAMFERS AT CORNERS ARE OPTIONAL. SIZE MAY VARY.

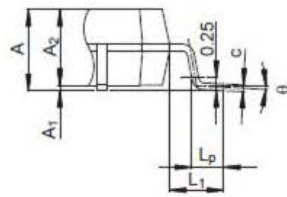
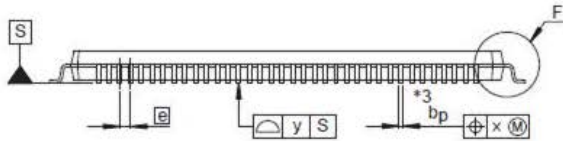

Detail F

Reference Symbol	Dimensions in millimeters		
	Min	Nom	Max
D	19.9	20.0	20.1
E	19.9	20.0	20.1
A ₂	—	1.4	—
H _D	21.8	22.0	22.2
H _E	21.8	22.0	22.2
A	—	—	1.7
A ₁	0.05	—	0.15
b _p	0.17	0.20	0.27
c	0.09	—	0.20
θ	0°	3.5°	8°
E	—	0.5	—
x	—	—	0.08
y	—	—	0.08
L _p	0.45	0.6	0.75
L ₁	—	1.0	—

Figure E 144-Pin LFQFP (PLQP0144KA-B)

JEITA Package Code	RENESAS Code	Previous Code	MASS (Typ) [g]
P-LFQFP100-14x14-0.50	PLQP0100KB-B	—	0.6

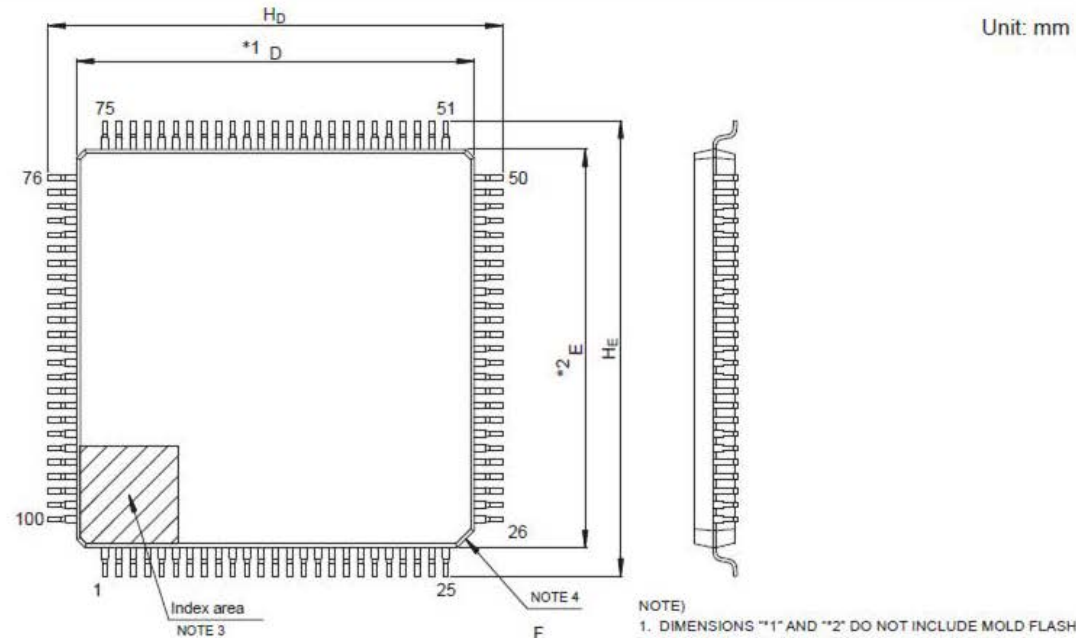

Unit: mm

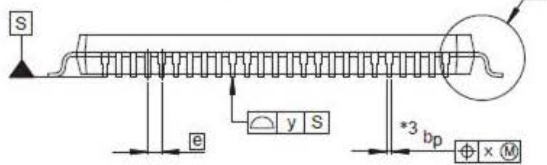

- NOTE)
1. DIMENSIONS **1* AND **2* DO NOT INCLUDE MOLD FLASH.
 2. DIMENSION **3* DOES NOT INCLUDE TRIM OFFSET.
 3. PIN 1 VISUAL INDEX FEATURE MAY VARY, BUT MUST BE LOCATED WITHIN THE HATCHED AREA.
 4. CHAMFERS AT CORNERS ARE OPTIONAL, SIZE MAY VARY.

Reference Symbol	Dimensions in millimeters		
	Min	Nom	Max
D	13.9	14.0	14.1
E	13.9	14.0	14.1
A ₂	—	1.4	—
H _D	15.8	16.0	16.2
H _E	15.8	16.0	16.2
A	—	—	1.7
A ₁	0.05	—	0.15
b _p	0.15	0.20	0.27
c	0.09	—	0.20
θ	0°	3.5°	8°
e	—	0.5	—
x	—	—	0.08
y	—	—	0.08
L _p	0.45	0.6	0.75
L ₁	—	1.0	—

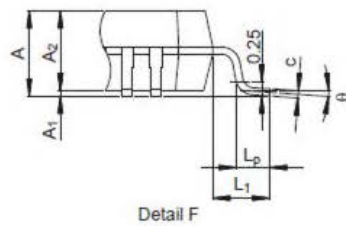

Figure F 100-Pin LFQFP (PLQP0100KB-B)

REVISION HISTORY	RX72N Group Datasheet
------------------	-----------------------

Classifications

- Items with Technical Update document number: Changes according to the corresponding issued Technical Update
- Items without Technical Update document number: Minor changes that do not require Technical Update to be issued

Rev.	Date	Description		Classification
		Page	Summary	
1.00	May 31, 2019	—	First edition, issued	
1.11	Feb 26, 2021	1. Overview		
		15, 16	Table 1.3 List of Products, changed	
		62, 63, 65	Table 1.8 List of Pin and Pin Functions (145-Pin TFLGA), changed	TN-RX*-A0222A/E
		70, 75	Table 1.9 List of Pin and Pin Functions (144-Pin LFQFP), changed	
		2. Electrical Characteristics		
		86, 87	Table 2.6 DC Characteristics (3), Note 3, changed	TN-RX*-A0222A/E
		95	Table 2.18 HOCO Clock Timing, changed	
		102	Table 2.26 Bus Timing, Conditions 1, Conditions 2, changed	TN-RX*-A0243A/E
		105	Figure 2.21 External Bus Timing/Normal Write Cycle (Bus Clock Synchronized), changed	
		106	Figure 2.23 External Bus Timing/Page Write Cycle (Bus Clock Synchronized), changed	
		115	Table 2.27 EXDMAC Timing, Conditions, changed	TN-RX*-A0243A/E
		116 to 155	2.4.7 Timing of On-Chip Peripheral Modules, order of tables changed	
		119	Figure 2.41 MTU Clock Input Timing, changed	TN-RX*-A0243A/E
		123	Figure 2.51 Output Disable Time of POEG in Response to the Oscillation Stop Detection, changed	
127	Figure 2.56 Simple IIC Bus Interface Input/Output Timing, added			
152	Table 2.48 GLCDC Timing, changed			

All trademarks and registered trademarks are the property of their respective owners.

General Precautions in the Handling of Microprocessing Unit and Microcontroller Unit Products

The following usage notes are applicable to all Microprocessing unit and Microcontroller unit products from Renesas. For detailed usage notes on the products covered by this document, refer to the relevant sections of the document as well as any technical updates that have been issued for the products.

1. Precaution against Electrostatic Discharge (ESD)

A strong electrical field, when exposed to a CMOS device, can cause destruction of the gate oxide and ultimately degrade the device operation. Steps must be taken to stop the generation of static electricity as much as possible, and quickly dissipate it when it occurs. Environmental control must be adequate. When it is dry, a humidifier should be used. This is recommended to avoid using insulators that can easily build up static electricity. Semiconductor devices must be stored and transported in an anti-static container, static shielding bag or conductive material. All test and measurement tools including work benches and floors must be grounded. The operator must also be grounded using a wrist strap. Semiconductor devices must not be touched with bare hands. Similar precautions must be taken for printed circuit boards with mounted semiconductor devices.

2. Processing at power-on

The state of the product is undefined at the time when power is supplied. The states of internal circuits in the LSI are indeterminate and the states of register settings and pins are undefined at the time when power is supplied. In a finished product where the reset signal is applied to the external reset pin, the states of pins are not guaranteed from the time when power is supplied until the reset process is completed. In a similar way, the states of pins in a product that is reset by an on-chip power-on reset function are not guaranteed from the time when power is supplied until the power reaches the level at which resetting is specified.

3. Input of signal during power-off state

Do not input signals or an I/O pull-up power supply while the device is powered off. The current injection that results from input of such a signal or I/O pull-up power supply may cause malfunction and the abnormal current that passes in the device at this time may cause degradation of internal elements. Follow the guideline for input signal during power-off state as described in your product documentation.

4. Handling of unused pins

Handle unused pins in accordance with the directions given under handling of unused pins in the manual. The input pins of CMOS products are generally in the high-impedance state. In operation with an unused pin in the open-circuit state, extra electromagnetic noise is induced in the vicinity of the LSI, an associated shoot-through current flows internally, and malfunctions occur due to the false recognition of the pin state as an input signal become possible.

5. Clock signals

After applying a reset, only release the reset line after the operating clock signal becomes stable. When switching the clock signal during program execution, wait until the target clock signal is stabilized. When the clock signal is generated with an external resonator or from an external oscillator during a reset, ensure that the reset line is only released after full stabilization of the clock signal. Additionally, when switching to a clock signal produced with an external resonator or by an external oscillator while program execution is in progress, wait until the target clock signal is stable.

6. Voltage application waveform at input pin

Waveform distortion due to input noise or a reflected wave may cause malfunction. If the input of the CMOS device stays in the area between V_{IL} (Max.) and V_{IH} (Min.) due to noise, for example, the device may malfunction. Take care to prevent chattering noise from entering the device when the input level is fixed, and also in the transition period when the input level passes through the area between V_{IL} (Max.) and V_{IH} (Min.).

7. Prohibition of access to reserved addresses

Access to reserved addresses is prohibited. The reserved addresses are provided for possible future expansion of functions. Do not access these addresses as the correct operation of the LSI is not guaranteed.

8. Differences between products

Before changing from one product to another, for example to a product with a different part number, confirm that the change will not lead to problems. The characteristics of a microprocessing unit or microcontroller unit products in the same group but having a different part number might differ in terms of internal memory capacity, layout pattern, and other factors, which can affect the ranges of electrical characteristics, such as characteristic values, operating margins, immunity to noise, and amount of radiated noise. When changing to a product with a different part number, implement a system-evaluation test for the given product.

Notice

1. Descriptions of circuits, software and other related information in this document are provided only to illustrate the operation of semiconductor products and application examples. You are fully responsible for the incorporation or any other use of the circuits, software, and information in the design of your product or system. Renesas Electronics disclaims any and all liability for any losses and damages incurred by you or third parties arising from the use of these circuits, software, or information.
2. Renesas Electronics hereby expressly disclaims any warranties against and liability for infringement or any other claims involving patents, copyrights, or other intellectual property rights of third parties, by or arising from the use of Renesas Electronics products or technical information described in this document, including but not limited to, the product data, drawings, charts, programs, algorithms, and application examples.
3. No license, express, implied or otherwise, is granted hereby under any patents, copyrights or other intellectual property rights of Renesas Electronics or others.
4. You shall be responsible for determining what licenses are required from any third parties, and obtaining such licenses for the lawful import, export, manufacture, sales, utilization, distribution or other disposal of any products incorporating Renesas Electronics products, if required.
5. You shall not alter, modify, copy, or reverse engineer any Renesas Electronics product, whether in whole or in part. Renesas Electronics disclaims any and all liability for any losses or damages incurred by you or third parties arising from such alteration, modification, copying or reverse engineering.
6. Renesas Electronics products are classified according to the following two quality grades: "Standard" and "High Quality". The intended applications for each Renesas Electronics product depends on the product's quality grade, as indicated below.

"Standard": Computers; office equipment; communications equipment; test and measurement equipment; audio and visual equipment; home electronic appliances; machine tools; personal electronic equipment; industrial robots; etc.

"High Quality": Transportation equipment (automobiles, trains, ships, etc.); traffic control (traffic lights); large-scale communication equipment; key financial terminal systems; safety control equipment; etc.

Unless expressly designated as a high reliability product or a product for harsh environments in a Renesas Electronics data sheet or other Renesas Electronics document, Renesas Electronics products are not intended or authorized for use in products or systems that may pose a direct threat to human life or bodily injury (artificial life support devices or systems; surgical implantations; etc.), or may cause serious property damage (space system; undersea repeaters; nuclear power control systems; aircraft control systems; key plant systems; military equipment; etc.). Renesas Electronics disclaims any and all liability for any damages or losses incurred by you or any third parties arising from the use of any Renesas Electronics product that is inconsistent with any Renesas Electronics data sheet, user's manual or other Renesas Electronics document.

7. No semiconductor product is absolutely secure. Notwithstanding any security measures or features that may be implemented in Renesas Electronics hardware or software products, Renesas Electronics shall have absolutely no liability arising out of any vulnerability or security breach, including but not limited to any unauthorized access to or use of a Renesas Electronics product or a system that uses a Renesas Electronics product. RENESAS ELECTRONICS DOES NOT WARRANT OR GUARANTEE THAT RENESAS ELECTRONICS PRODUCTS, OR ANY SYSTEMS CREATED USING RENESAS ELECTRONICS PRODUCTS WILL BE INVULNERABLE OR FREE FROM CORRUPTION, ATTACK, VIRUSES, INTERFERENCE, HACKING, DATA LOSS OR THEFT, OR OTHER SECURITY INTRUSION ("Vulnerability Issues"). RENESAS ELECTRONICS DISCLAIMS ANY AND ALL RESPONSIBILITY OR LIABILITY ARISING FROM OR RELATED TO ANY VULNERABILITY ISSUES. FURTHERMORE, TO THE EXTENT PERMITTED BY APPLICABLE LAW, RENESAS ELECTRONICS DISCLAIMS ANY AND ALL WARRANTIES, EXPRESS OR IMPLIED, WITH RESPECT TO THIS DOCUMENT AND ANY RELATED OR ACCOMPANYING SOFTWARE OR HARDWARE, INCLUDING BUT NOT LIMITED TO THE IMPLIED WARRANTIES OF MERCHANTABILITY, OR FITNESS FOR A PARTICULAR PURPOSE.
8. When using Renesas Electronics products, refer to the latest product information (data sheets, user's manuals, application notes, "General Notes for Handling and Using Semiconductor Devices" in the reliability handbook, etc.), and ensure that usage conditions are within the ranges specified by Renesas Electronics with respect to maximum ratings, operating power supply voltage range, heat dissipation characteristics, installation, etc. Renesas Electronics disclaims any and all liability for any malfunctions, failure or accident arising out of the use of Renesas Electronics products outside of such specified ranges.
9. Although Renesas Electronics endeavors to improve the quality and reliability of Renesas Electronics products, semiconductor products have specific characteristics, such as the occurrence of failure at a certain rate and malfunctions under certain use conditions. Unless designated as a high reliability product or a product for harsh environments in a Renesas Electronics data sheet or other Renesas Electronics document, Renesas Electronics products are not subject to radiation resistance design. You are responsible for implementing safety measures to guard against the possibility of bodily injury, injury or damage caused by fire, and/or danger to the public in the event of a failure or malfunction of Renesas Electronics products, such as safety design for hardware and software, including but not limited to redundancy, fire control and malfunction prevention, appropriate treatment for aging degradation or any other appropriate measures. Because the evaluation of microcomputer software alone is very difficult and impractical, you are responsible for evaluating the safety of the final products or systems manufactured by you.
10. Please contact a Renesas Electronics sales office for details as to environmental matters such as the environmental compatibility of each Renesas Electronics product. You are responsible for carefully and sufficiently investigating applicable laws and regulations that regulate the inclusion or use of controlled substances, including without limitation, the EU RoHS Directive, and using Renesas Electronics products in compliance with all these applicable laws and regulations. Renesas Electronics disclaims any and all liability for damages or losses occurring as a result of your noncompliance with applicable laws and regulations.
11. Renesas Electronics products and technologies shall not be used for or incorporated into any products or systems whose manufacture, use, or sale is prohibited under any applicable domestic or foreign laws or regulations. You shall comply with any applicable export control laws and regulations promulgated and administered by the governments of any countries asserting jurisdiction over the parties or transactions.
12. It is the responsibility of the buyer or distributor of Renesas Electronics products, or any other party who distributes, disposes of, or otherwise sells or transfers the product to a third party, to notify such third party in advance of the contents and conditions set forth in this document.
13. This document shall not be reprinted, reproduced or duplicated in any form, in whole or in part, without prior written consent of Renesas Electronics.
14. Please contact a Renesas Electronics sales office if you have any questions regarding the information contained in this document or Renesas Electronics products.

(Note1) "Renesas Electronics" as used in this document means Renesas Electronics Corporation and also includes its directly or indirectly controlled subsidiaries.

(Note2) "Renesas Electronics product(s)" means any product developed or manufactured by or for Renesas Electronics.

(Rev.5.0-1 October 2020)

Corporate Headquarters

TOYOSU FORESIA, 3-2-24 Toyosu,
Koto-ku, Tokyo 135-0061, Japan
www.renesas.com

Trademarks

Renesas and the Renesas logo are trademarks of Renesas Electronics Corporation. All trademarks and registered trademarks are the property of their respective owners.

Contact Information

For further information on a product, technology, the most up-to-date version of a document, or your nearest sales office, please visit:
www.renesas.com/contact/

X-ON Electronics

Largest Supplier of Electrical and Electronic Components

Click to view similar products for [32-bit Microcontrollers - MCU category](#):

Click to view products by [Renesas manufacturer](#):

Other Similar products are found below :

[MB91F575BHSPMC-GSE1](#) [MB91F594BSPMC-GSE1](#) [PIC32MX120F032B-50I/ML](#) [MB91F464AAPMC-GSE2](#) [MB91F577BHSPMC-GSE1](#)
[SPC5604EEF2MLH](#) [MB91F528USCPMC-GSE2](#) [MB91F248PFV-GE1](#) [MB91F594BPMC-GSE1](#) [MB91243PFV-GS-136E1](#)
[MB91F577BHSPMC1-GSE1](#) [PIC32MM0032GPL020-E/ML](#) [PIC32MM0032GPL020-E/SS](#) [MEC1632X-AUE](#) [PIC32MM0016GPL020-E/ML](#)
[PIC32MM0016GPL020-E/SS](#) [PIC32MM0016GPL028-E/SS](#) [PIC32MM0016GPL028-E/SO](#) [PIC32MM0016GPL028-E/ML](#)
[PIC32MM0032GPL028-E/SS](#) [PIC32MM0032GPL028-E/SO](#) [PIC32MM0032GPL028-E/ML](#) [PIC32MM0032GPL036-E/MV](#)
[PIC32MM0064GPL028-E/M6](#) [PIC32MM0016GPL028-E/M6](#) [PIC32MM0032GPL028-E/M6](#) [MB91F526KSEPMC-GSE1](#)
[PIC32MM0064GPL028-E/SP](#) [PIC32MM0032GPL036-E/M2](#) [TLE9872QTW40XUMA1](#) [FT902L-T](#) [R5F564MLCDFB#31](#)
[R5F564MLCDFC#31](#) [R5F523E5ADFL#30](#) [R5F524TAADFF#31](#) [MCF51AC256ACPUE](#) [PIC32MM0064GPL028-I/ML](#)
[PIC32MM0064GPL028-I/SP](#) [PIC32MM0064GPL028-I/SO](#) [PIC32MX120F032D-I/TL](#) [PIC32MX130F064D-I/ML](#) [PIC32MZ2064DAB169-](#)
[I/HF](#) [PIC32MZ2064DAB288-I/4J](#) [ATUC256L4U-AUT](#) [R5F56318CDBG#U0](#) [PIC32MX150F128C-I/TL](#) [PIC32MX170F256B-50IML](#)
[PIC32MX130F064C-ITL](#) [PIC32MX230F064D-IML](#) [PIC32MM0032GPL028-I/ML](#)