

Ultra low power 48 MHz Arm® Cortex®-M23 core, up to 256-KB code flash memory, 32 KB SRAM, Capacitive Sensing Unit (CTS2U), 12-bit A/D Converter, 12-bit D/A Converter, Security and Safety features.

Features

- **Arm Cortex-M23 Core**
 - Armv8-M architecture
 - Maximum operating frequency: 48 MHz
 - Arm Memory Protection Unit (Arm MPU) with 8 regions
 - Debug and Trace: DWT, FPB, CoreSight™ MTB-M23
 - CoreSight Debug Port: SW-DP
- **Memory**
 - Up to 256-KB code flash memory
 - 8-KB data flash memory (100,000 program/erase (P/E) cycles)
 - 32 KB SRAM
 - Memory protection units
 - 128-bit unique ID
- **Connectivity**
 - Serial Communications Interface (SCI) × 5
 - Asynchronous interfaces
 - 8-bit clock synchronous interface
 - Simple IIC
 - Simple SPI
 - Smart card interface
 - Serial Peripheral Interface (SPI) × 2
 - I²C bus interface (IIC) × 2
 - CAN module (CAN)
- **Analog**
 - 12-bit A/D Converter (ADC12)
 - 12-bit D/A Converter (DAC12)
 - Low-Power Analog Comparator (ACMPLP) × 2
 - Temperature Sensor (TSN)
- **Timers**
 - General PWM Timer 32-bit (GPT32) × 4
 - General PWM Timer 16-bit (GPT16) × 6
 - Low Power Asynchronous General Purpose Timer (AGT) × 2
 - Watchdog Timer (WDT)
- **Safety**
 - ECC in SRAM
 - SRAM parity error check
 - Flash area protection
 - ADC self-diagnosis function
 - Clock Frequency Accuracy Measurement Circuit (CAC)
 - Cyclic Redundancy Check (CRC) calculator
 - Data Operation Circuit (DOC)
 - Port Output Enable for GPT (POEG)
 - Independent Watchdog Timer (IWDT)
 - GPIO readback level detection
 - Register write protection
 - Main oscillator stop detection
 - Illegal memory access
- **Security and Encryption**
 - AES128/256
 - True Random Number Generator (TRNG)
- **System and Power Management**
 - Low power modes
 - Switching regulator
 - Realtime Clock (RTC)
 - Event Link Controller (ELC)
 - Data Transfer Controller (DTC)
 - Key Interrupt Function (KINT)
 - Power-on reset
 - Low Voltage Detection (LVD) with voltage settings
- **Human Machine Interface (HMI)**
 - Capacitive Sensing Unit (CTS2U)
- **Multiple Clock Sources**
 - Main clock oscillator (MOSC) (1 to 20 MHz)
 - Sub-clock oscillator (SOSC) (32.768 kHz)
 - High-speed on-chip oscillator (HOCO) (24/32/48/64 MHz)
 - Middle-speed on-chip oscillator (MOCO) (8 MHz)
 - Low-speed on-chip oscillator (LOCO) (32.768 kHz)
 - Clock trim function for HOCO/MOCO/LOCO
 - IWDT-dedicated on-chip oscillator (15 kHz)
 - Clock out support
- **Up to 85 pins for general I/O ports**
 - 5-V tolerance, open drain, input pull-up
- **Operating Voltage**
 - VCC: 1.6 to 5.5 V
- **Operating Temperature and Packages**
 - Ta = -40°C to +85°C
 - 100-pin LQFP (14 mm × 14 mm, 0.5 mm pitch)
 - 80-pin LQFP (12 mm × 12 mm, 0.5 mm pitch)
 - 64-pin LQFP (10 mm × 10 mm, 0.5 mm pitch)
 - 48-pin LQFP (7 mm × 7 mm, 0.50 mm pitch)
 - 48-pin HWQFN (7 mm × 7 mm, 0.50 mm pitch)
 - Ta = -40°C to +105°C
 - 100-pin LQFP (14 mm × 14 mm, 0.5 mm pitch)
 - 80-pin LQFP (12 mm × 12 mm, 0.5 mm pitch)
 - 64-pin LQFP (10 mm × 10 mm, 0.5 mm pitch)
 - 48-pin LQFP (7 mm × 7 mm, 0.50 mm pitch)
 - 48-pin HWQFN (7 mm × 7 mm, 0.50 mm pitch)

1. Overview

The MCU integrates multiple series of software- and pin-compatible Arm[®]-based 32-bit cores that share a common set of Renesas peripherals to facilitate design scalability.

The MCU in this series incorporates an energy-efficient Arm Cortex[®]-M23 32-bit core, that is particularly well suited for cost-sensitive and low-power applications, with the following features:

- Up to 256-KB code flash memory
- 32-KB SRAM
- 12-bit A/D Converter (ADC12)
- 12-bit D/A Converter (DAC12)
- Security features

1.1 Function Outline

Table 1.1 Arm core

| Feature | Functional description |
|---------------------|---|
| Arm Cortex-M23 core | <ul style="list-style-type: none"> • Maximum operating frequency: up to 48 MHz • Arm Cortex-M23 core: <ul style="list-style-type: none"> – Revision: r1p0-00rel0 – Armv8-M architecture profile – Single-cycle integer multiplier – 19-cycle integer divider • Arm Memory Protection Unit (Arm MPU): <ul style="list-style-type: none"> – Armv8 Protected Memory System Architecture – 8 protect regions • SysTick timer: <ul style="list-style-type: none"> – Driven by SYSTICCLK (LOCO) or ICLK |

Table 1.2 Memory

| Feature | Functional description |
|-----------------------|--|
| Code flash memory | Maximum 256 KB of code flash memory. |
| Data flash memory | 8 KB of data flash memory. |
| Option-setting memory | The option-setting memory determines the state of the MCU after a reset. |
| SRAM | On-chip high-speed SRAM with either parity bit or Error Correction Code (ECC). |

Table 1.3 System (1 of 2)

| Feature | Functional description |
|-----------------------------|--|
| Operating modes | Two operating modes: <ul style="list-style-type: none"> • Single-chip mode • SCI boot mode |
| Resets | The MCU provides 13 resets. |
| Low Voltage Detection (LVD) | The Low Voltage Detection (LVD) module monitors the voltage level input to the VCC pin. The detection level can be selected by register settings. The LVD module consists of three separate voltage level detectors (LVD0, LVD1, LVD2). LVD0, LVD1, and LVD2 measure the voltage level input to the VCC pin. LVD registers allow your application to configure detection of VCC changes at various voltage thresholds. |
| Clocks | <ul style="list-style-type: none"> • Main clock oscillator (MOSC) • Sub-clock oscillator (SOSC) • High-speed on-chip oscillator (HOCO) • Middle-speed on-chip oscillator (MOCO) • Low-speed on-chip oscillator (LOCO) • IWDT-dedicated on-chip oscillator (IWDTLOCO) • Clock out support |

Table 1.3 System (2 of 2)

| Feature | Functional description |
|--|--|
| Clock Frequency Accuracy Measurement Circuit (CAC) | The Clock Frequency Accuracy Measurement Circuit (CAC) counts pulses of the clock to be measured (measurement target clock) within the time generated by the clock selected as the measurement reference (measurement reference clock), and determines the accuracy depending on whether the number of pulses is within the allowable range. When measurement is complete or the number of pulses within the time generated by the measurement reference clock is not within the allowable range, an interrupt request is generated. |
| Interrupt Controller Unit (ICU) | The Interrupt Controller Unit (ICU) controls which event signals are linked to the Nested Vector Interrupt Controller (NVIC), and the Data Transfer Controller (DTC) modules. The ICU also controls non-maskable interrupts. |
| Key Interrupt Function (KINT) | The key interrupt function (KINT) generates the key interrupt by detecting rising or falling edge on the key interrupt input pins. |
| Low power modes | Power consumption can be reduced in multiple ways, including setting clock dividers, stopping modules, selecting power control mode in normal operation, and transitioning to low power modes. |
| Register write protection | The register write protection function protects important registers from being overwritten due to software errors. The registers to be protected are set with the Protect Register (PRCR). |
| Memory Protection Unit (MPU) | The MCU has four Memory Protection Units (MPUs) and a CPU stack pointer monitor function are provided. |
| Watchdog Timer (WDT) | The Watchdog Timer (WDT) is a 14-bit down counter that can be used to reset the MCU when the counter underflows because the system has run out of control and is unable to refresh the WDT. In addition, the WDT can be used to generate a non-maskable interrupt or an underflow interrupt or watchdog timer reset. |
| Independent Watchdog Timer (IWDT) | The Independent Watchdog Timer (IWDT) consists of a 14-bit down counter that must be serviced periodically to prevent counter underflow. The IWDT provides functionality to reset the MCU or to generate a non-maskable interrupt or an underflow interrupt. Because the timer operates with an independent, dedicated clock source, it is particularly useful in returning the MCU to a known state as a fail-safe mechanism when the system runs out of control. The IWDT can be triggered automatically by a reset, underflow, refresh error, or a refresh of the count value in the registers. |

Table 1.4 Event link

| Feature | Functional description |
|-----------------------------|--|
| Event Link Controller (ELC) | The Event Link Controller (ELC) uses the event requests generated by various peripheral modules as source signals to connect them to different modules, allowing direct link between the modules without CPU intervention. |

Table 1.5 Direct memory access

| Feature | Functional description |
|--------------------------------|---|
| Data Transfer Controller (DTC) | A Data Transfer Controller (DTC) module is provided for transferring data when activated by an interrupt request. |

Table 1.6 Timers (1 of 2)

| Feature | Functional description |
|--|---|
| General PWM Timer (GPT) | The General PWM Timer (GPT) is a 32-bit timer with GPT32 × 4 channels and a 16-bit timer with GPT16 × 6 channels. PWM waveforms can be generated by controlling the up-counter, down-counter, or the up- and down-counter. In addition, PWM waveforms can be generated for controlling brushless DC motors. The GPT can also be used as a general-purpose timer. |
| Port Output Enable for GPT (POEG) | The Port Output Enable (POEG) function can place the General PWM Timer (GPT) output pins in the output disable state |
| Low power Asynchronous General Purpose Timer (AGT) | The Low Power Asynchronous General Purpose Timer (AGT) is a 16-bit timer that can be used for pulse output, external pulse width or period measurement, and counting external events. This timer consists of a reload register and a down counter. The reload register and the down counter are allocated to the same address, and can be accessed with the AGT register. |

Table 1.6 Timers (2 of 2)

| Feature | Functional description |
|----------------------|---|
| Realtime Clock (RTC) | The RTC has two operation modes, normal operation mode and low-consumption clock mode. In each of the operation mode, the RTC has two counting modes, calendar count mode and binary count mode, that are used by switching register settings. For calendar count mode, the RTC has a 100-year calendar from 2000 to 2099 and automatically adjusts dates for leap years. For binary count mode, the RTC counts seconds and retains the information as a serial value. Binary count mode can be used for calendars other than the Gregorian (Western) calendar. |

Table 1.7 Communication interfaces

| Feature | Functional description |
|---------------------------------------|---|
| Serial Communications Interface (SCI) | The Serial Communications Interface (SCI) × 5 channels have asynchronous and synchronous serial interfaces: <ul style="list-style-type: none"> Asynchronous interfaces (UART and Asynchronous Communications Interface Adapter (ACIA)) 8-bit clock synchronous interface Simple IIC (master-only) Simple SPI Smart card interface The smart card interface complies with the ISO/IEC 7816-3 standard for electronic signals and transmission protocol. SCIn (n = 0) has FIFO buffers to enable continuous and full-duplex communication, and the data transfer speed can be configured independently using an on-chip baud rate generator. |
| I ² C bus interface (IIC) | The I ² C bus interface (IIC) has 2 channels. The IIC module conforms with and provides a subset of the NXP I ² C (Inter-Integrated Circuit) bus interface functions. |
| Serial Peripheral Interface (SPI) | The Serial Peripheral Interface (SPI) has 2 channels. The SPI provides high-speed full-duplex synchronous serial communications with multiple processors and peripheral devices. |
| Control Area Network (CAN) | The Controller Area Network (CAN) module uses a message-based protocol to receive and transmit data between multiple slaves and masters in electromagnetically noisy applications. The module complies with the ISO 11898-1 (CAN 2.0A/CAN 2.0B) standard and supports up to 32 mailboxes, which can be configured for transmission or reception in normal mailbox and FIFO modes. Both standard (11-bit) and extended (29-bit) messaging formats are supported. The CAN module requires an additional external CAN transceiver. |

Table 1.8 Analog

| Feature | Functional description |
|--------------------------------------|--|
| 12-bit A/D Converter (ADC12) | A 12-bit successive approximation A/D converter is provided. Up to 19 analog input channels are selectable. Temperature sensor output and internal reference voltage are selectable for conversion. |
| 12-bit D/A Converter (DAC12) | A 12-bit D/A converter (DAC12) is provided. |
| Temperature Sensor (TSN) | The on-chip Temperature Sensor (TSN) determines and monitors the die temperature for reliable operation of the device. The sensor outputs a voltage directly proportional to the die temperature, and the relationship between the die temperature and the output voltage is fairly linear. The output voltage is provided to the ADC12 for conversion and can be further used by the end application. |
| Low-Power Analog Comparator (ACMPLP) | The Low-Power Analog Comparator (ACMPLP) compares a reference input voltage with an analog input voltage. Comparator channels ACMPLP0 and ACMPLP1 are independent of each other. The comparison result of the reference input voltage and analog input voltage can be read by software. The comparison result can also be output externally. The reference input voltage can be selected from either an input to the CMPREFi (i = 0, 1) pin or from the internal reference voltage (Vref) generated internally in the MCU. The ACMPLP response speed can be set before starting an operation. Setting high-speed mode decreases the response delay time, but increases current consumption. Setting low-speed mode increases the response delay time, but decreases current consumption. |

Table 1.9 Human machine interfaces

| Feature | Functional description |
|--------------------------------|--|
| Capacitive Sensing Unit (CTS2) | The Capacitive Sensing Unit (CTS2) measures the electrostatic capacitance of the sensor. Changes in the electrostatic capacitance are determined by software that enables the CTSU to detect whether a finger is in contact with the sensor. The electrode surface of the sensor is usually enclosed with a dielectric film so that a finger does not come into direct contact with the electrode. |

Table 1.10 Data processing

| Feature | Functional description |
|--|--|
| Cyclic Redundancy Check (CRC) calculator | The Cyclic Redundancy Check (CRC) generates CRC codes to detect errors in the data. The bit order of CRC calculation results can be switched for LSB-first or MSB-first communication. Additionally, various CRC-generation polynomials are available. The snoop function allows to monitor the access to specific addresses. This function is useful in applications that require CRC code to be generated automatically in certain events, such as monitoring writes to the serial transmit buffer and reads from the serial receive buffer. |
| Data Operation Circuit (DOC) | The Data Operation Circuit (DOC) compares, adds, and subtracts 16-bit data. When a selected condition applies, 16-bit data is compared and an interrupt can be generated. |

Table 1.11 I/O ports

| Feature | Functional description |
|-----------|---|
| I/O ports | <ul style="list-style-type: none"> ● I/O ports for the 100-pin LQFP <ul style="list-style-type: none"> – I/O pins: 82 – Input pins: 3 – Pull-up resistors: 82 – N-ch open-drain outputs: 65 – 5-V tolerance: 5 ● I/O ports for the 80-pin LQFP <ul style="list-style-type: none"> – I/O pins: 66 – Input pins: 3 – Pull-up resistors: 66 – N-ch open-drain outputs: 51 – 5-V tolerance: 5 ● I/O ports for the 64-pin LQFP <ul style="list-style-type: none"> – I/O pins: 50 – Input pins: 3 – Pull-up resistors: 50 – N-ch open-drain outputs: 37 – 5-V tolerance: 5 ● I/O ports for the 48-pin LQFP/HWQFN <ul style="list-style-type: none"> – I/O pins: 34 – Input pins: 3 – Pull-up resistors: 34 – N-ch open-drain outputs: 23 – 5-V tolerance: 4 |

1.2 Block Diagram

Figure 1.1 shows a block diagram of the MCU superset. Some individual devices within the group have a subset of the features.

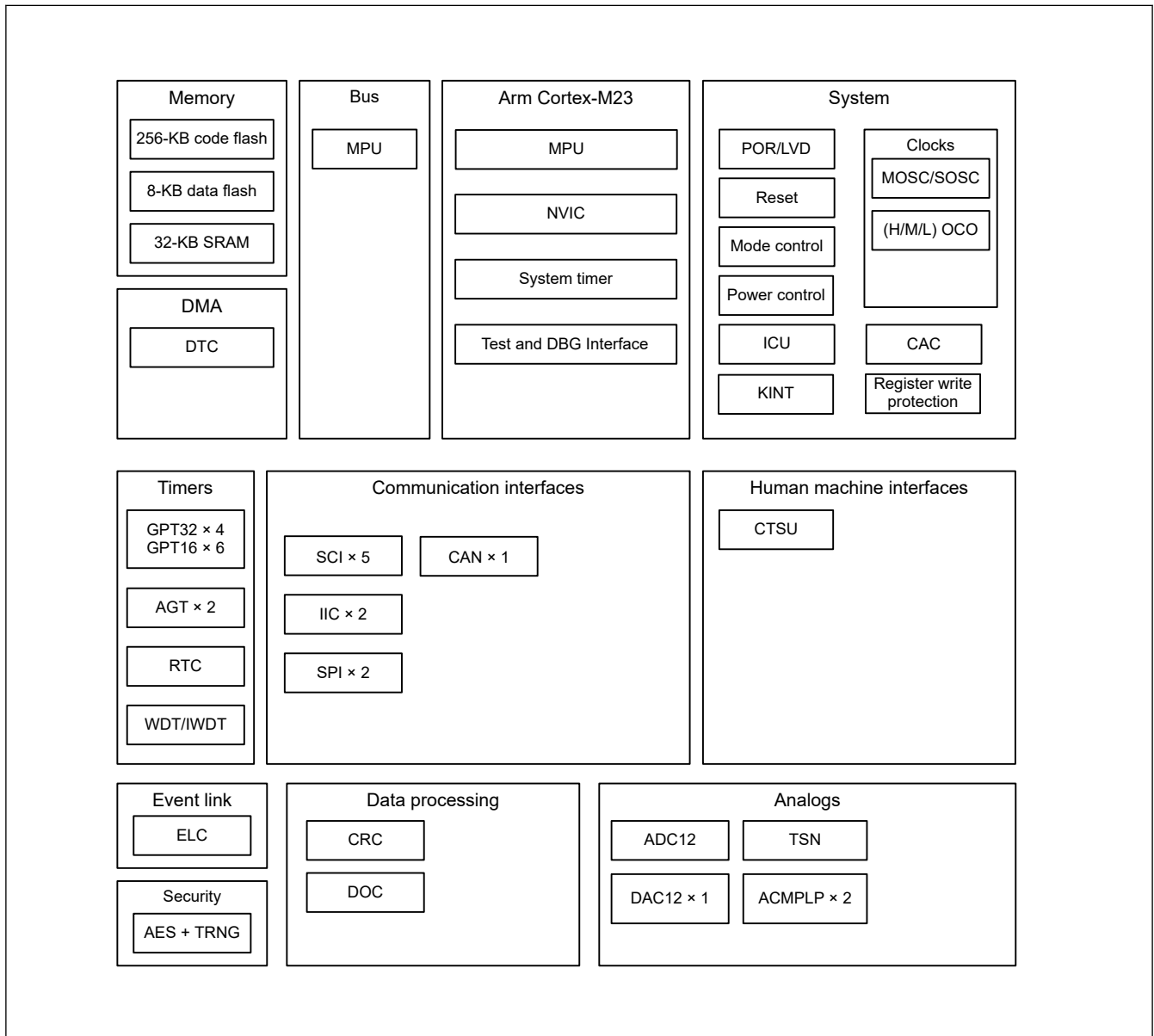

Figure 1.1 Block diagram

1.3 Part Numbering

Figure 1.2 shows the product part number information, including memory capacity and package type. Table 1.12 shows a list of products.

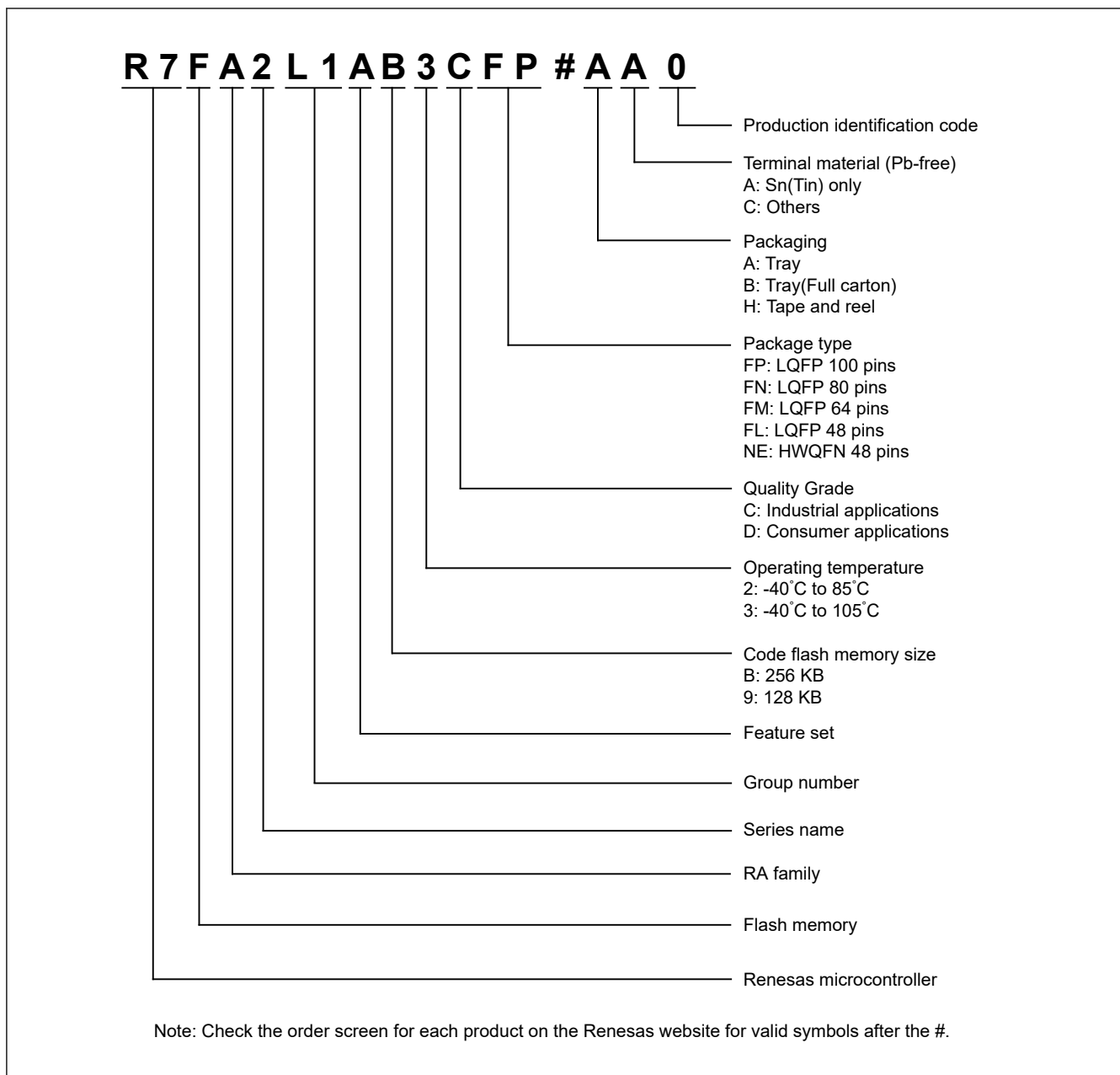

Figure 1.2 Part numbering scheme

Table 1.12 Product list

| Product part number | Package code | Code flash | Data flash | SRAM | Operating temperature |
|---------------------|------------------------------|------------|------------|-------|-----------------------|
| R7FA2L1AB3CFP | PLQP0100KB-B | 256 KB | 8 KB | 32 KB | -40 to +105°C |
| R7FA2L1AB3CFN | PLQP0080KB-B | | | | |
| R7FA2L1AB3CFM | PLQP0064KB-C PLQP0064KL-A | | | | |
| R7FA2L1AB3CFL | PLQP0048KB-B PLQP0048KL-A | | | | |
| R7FA2L1AB3CNE | PWQN0048KC-A | | | | |
| R7FA2L1AB2DFP | PLQP0100KB-B | | | | -40 to +85°C |
| R7FA2L1AB2DFN | PLQP0080KB-B | | | | |
| R7FA2L1AB2DFM | PLQP0064KB-C PLQP0064KL-A | | | | |
| R7FA2L1AB2DFL | PLQP0048KB-B PLQP0048KL-A | | | | |
| R7FA2L1AB2DNE | PWQN0048KC-A | | | | |
| R7FA2L1A93CFP | PLQP0100KB-B | 128 KB | 8 KB | 32 KB | -40 to +105°C |
| R7FA2L1A93CFN | PLQP0080KB-B | | | | |
| R7FA2L1A93CFM | PLQP0064KB-C PLQP0064KL-A | | | | |
| R7FA2L1A93CFL | PLQP0048KB-B PLQP0048KL-A | | | | |
| R7FA2L1A93CNE | PWQN0048KC-A | | | | |
| R7FA2L1A92DFP | PLQP0100KB-B | | | | -40 to +85°C |
| R7FA2L1A92DFN | PLQP0080KB-B | | | | |
| R7FA2L1A92DFM | PLQP0064KB-C PLQP0064KL-A | | | | |
| R7FA2L1A92DFL | PLQP0048KB-B PLQP0048KL-A | | | | |
| R7FA2L1A92DNE | PWQN0048KC-A | | | | |

1.4 Function Comparison

Table 1.13 Function comparison

| Parts number | R7FA2L1A BxxFP | R7FA2L1A 9xxFP | R7FA2L1A BxxFN | R7FA2L1A 9xxFN | R7FA2L1A BxxFM | R7FA2L1A 9xxFM | R7FA2L1A BxxFL R7FA2L1A BxxNE | R7FA2L1A 9xxFL R7FA2L1A 9xxNE |
|-------------------|-------------------------|-------------------|-------------------|-------------------|-------------------|-------------------|--|--|
| Pin count | 100 | | 80 | | 64 | | 48 | |
| Package | LQFP | LQFP | LQFP | LQFP | LQFP | LQFP | LQFP/QFN | LQFP/QFN |
| Code flash memory | 256 KB | 128 KB | 256 KB | 128 KB | 256 KB | 128 KB | 256 KB | 128 KB |
| Data flash memory | 8 KB | | | | | | | |
| SRAM | 32 KB | | | | | | | |
| | Parity | 16 KB | | | | | | |
| | ECC | 16 KB | | | | | | |
| System | CPU clock | 48 MHz | | | | | | |
| | Sub-clock oscillator | Yes | | | | | | |
| | ICU | Yes | | | | | | |
| | KINT | 8 | | | | | 5 | |
| Event control | ELC | Yes | | | | | | |
| DMA | DTC | Yes | | | | | | |
| Timers | GPT32 | 4 | | | | | | |
| | GPT16 | 6 | | | | | 3 | |
| | AGT | 2 | | | | | | |
| | RTC | Yes | | | | | | |
| | WDT/IWDT | Yes | | | | | | |
| Communication | SCI | 5 | | | | | | |
| | IIC | 2 | | | | | | |
| | SPI | 2 | | | | | | |
| | CAN | Yes | | | | | | |
| Analog | ADC12 | 19 | 17 | | 13 | | 9 | |
| | DAC12 | 1 | | | | | | |
| | ACMPLP | 2 | | | | | | |
| | TSN | Yes | | | | | | |
| HMI | CTSU | 32 | | | 30 | | 20 | |
| Data processing | CRC | Yes | | | | | | |
| | DOC | Yes | | | | | | |
| Security | AES and TRNG | | | | | | | |
| I/O ports | I/O pins | 82 | 66 | | 50 | | 34 | |
| | Input pins | 3 | 3 | | 3 | | 3 | |
| | Pull-up resistors | 82 | 66 | | 50 | | 34 | |
| | N-ch open-drain outputs | 65 | 51 | | 37 | | 23 | |
| | 5-V tolerance | 5 | 5 | | 5 | | 4 | |

1.5 Pin Functions

Table 1.14 Pin functions (1 of 3)

| Function | Signal | I/O | Description |
|------------------------|--|--------|--|
| Power supply | VCC | Input | Power supply pin. Connect it to the system power supply. Connect this pin to VSS by a 0.1- μ F capacitor. Place the capacitor close to the pin. |
| | VCL | I/O | Connect this pin to the VSS pin by the smoothing capacitor used to stabilize the internal power supply. Place the capacitor close to the pin. |
| | VSS | Input | Ground pin. Connect it to the system power supply (0 V). |
| | VCC_DCDC | Input | Switching regulator power supply pin |
| | VLO | I/O | Switching regulator pin |
| | VSS_DCDC | Input | Switching regulator ground pin. Connect it to the system power supply (0 V). |
| Clock | XTAL | Output | Pins for a crystal resonator. An external clock signal can be input through the EXTAL pin. |
| | EXTAL | Input | |
| | XCIN | Input | Input/output pins for the sub-clock oscillator. Connect a crystal resonator between XCOOUT and XCIN. |
| | XCOOUT | Output | |
| | CLKOUT | Output | Clock output pin |
| Operating mode control | MD | Input | Pin for setting the operating mode. The signal level on this pin must not be changed during operation mode transition on release from the reset state. |
| System control | RES | Input | Reset signal input pin. The MCU enters the reset state when this signal goes low. |
| CAC | CACREF | Input | Measurement reference clock input pin |
| On-chip debug | SWDIO | I/O | Serial wire debug data input/output pin |
| | SWCLK | Input | Serial wire clock pin |
| Interrupt | NMI | Input | Non-maskable interrupt request pin |
| | IRQ0 to IRQ7 | Input | Maskable interrupt request pins |
| GPT | GTETRGA, GTETRGB | Input | External trigger input pins |
| | GTIOcNA (n = 0 to 9), GTIOcNB (n = 0 to 9) | I/O | Input capture, output compare, or PWM output pins |
| | GTIU | Input | Hall sensor input pin U |
| | GTIV | Input | Hall sensor input pin V |
| | GTIW | Input | Hall sensor input pin W |
| | GTOUUP | Output | 3-phase PWM output for BLDC motor control (positive U phase) |
| | GTOULO | Output | 3-phase PWM output for BLDC motor control (negative U phase) |
| | GTOVUP | Output | 3-phase PWM output for BLDC motor control (positive V phase) |
| | GTOVLO | Output | 3-phase PWM output for BLDC motor control (negative V phase) |
| | GTOWUP | Output | 3-phase PWM output for BLDC motor control (positive W phase) |
| | GTOWLO | Output | 3-phase PWM output for BLDC motor control (negative W phase) |
| AGT | AGTEE0, AGTEE1 | Input | External event input enable signals |
| | AGTIO0, AGTIO1 | I/O | External event input and pulse output pins |
| | AGTO0, AGTO1 | Output | Pulse output pins |
| | AGTOA0, AGTOA1 | Output | Output compare match A output pins |
| | AGTOB0, AGTOB1 | Output | Output compare match B output pins |

Table 1.14 Pin functions (2 of 3)

| Function | Signal | I/O | Description |
|---------------------|--|--------|---|
| RTC | RTCCOUT | Output | Output pin for 1-Hz or 64-Hz clock |
| SCI | SCKn (n = 0 to 3, 9) | I/O | Input/output pins for the clock (clock synchronous mode) |
| | RXDn (n = 0 to 3, 9) | Input | Input pins for received data (asynchronous mode/clock synchronous mode) |
| | TXDn (n = 0 to 3, 9) | Output | Output pins for transmitted data (asynchronous mode/clock synchronous mode) |
| | CTS _n _RTS _n (n = 0 to 3, 9) | I/O | Input/output pins for controlling the start of transmission and reception (asynchronous mode/clock synchronous mode), active-low. |
| | SCLn (n = 0 to 3, 9) | I/O | Input/output pins for the IIC clock (simple IIC mode) |
| | SDAn (n = 0 to 3, 9) | I/O | Input/output pins for the IIC data (simple IIC mode) |
| | SCKn (n = 0 to 3, 9) | I/O | Input/output pins for the clock (simple SPI mode) |
| | MISO _n (n = 0 to 3, 9) | I/O | Input/output pins for slave transmission of data (simple SPI mode) |
| | MOSI _n (n = 0 to 3, 9) | I/O | Input/output pins for master transmission of data (simple SPI mode) |
| | SS _n (n = 0 to 3, 9) | Input | Chip-select input pins (simple SPI mode), active-low |
| IIC | SCLn (n = 0, 1) | I/O | Input/output pins for the clock |
| | SDAn (n = 0, 1) | I/O | Input/output pins for data |
| SPI | RSPCKA, RSPCKB | I/O | Clock input/output pin |
| | MOSIA, MOSIB | I/O | Input or output pins for data output from the master |
| | MISOA, MISOB | I/O | Input or output pins for data output from the slave |
| | SSLA0, SSLB0 | I/O | Input or output pin for slave selection |
| | SSLA1 to SSLA3, SSLB1 to SSLB3 | Output | Output pins for slave selection |
| CAN | CRX0 | Input | Receive data |
| | CTX0 | Output | Transmit data |
| Analog power supply | AVCC0 | Input | Analog voltage supply pin for the ADC12, DAC12 |
| | AVSS0 | Input | Analog ground pin for the ADC12, DAC12 |
| | VREFH0 | Input | Analog reference voltage supply pin for the ADC12. Connect this pin to AVCC0 when not using the ADC12. |
| | VREFL0 | Input | Analog reference ground pin for the ADC12. Connect this pin to AVSS0 when not using the ADC12. |
| ADC12 | AN000 to AN014, AN017 to AN020 | Input | Input pins for the analog signals to be processed by the A/D converter. |
| | ADTRG0 | Input | Input pin for the external trigger signals that start the A/D conversion, active-low. |
| DAC12 | DA0 | Output | Output pin for the analog signals processed by the D/A converter. |
| ACMPLP | VCOUT | Output | Comparator output pin |
| | CMPREF0, CMPREF1 | Input | Reference voltage input pins |
| | CMPIN0, CMPIN1 | Input | Analog voltage input pins |
| CTSU | TS00, TS02-CFC, TS04 to TS07, TS08-CFC to TS16-CFC, TS17, TS18, TS21 to TS25, TS26-CFC to TS35-CFC | Input | Capacitive touch detection pins (touch pins) |
| | TSCAP | — | Secondary power supply pin for the touch driver |
| KINT | KR00 to KR07 | Input | Key interrupt input pins |

Table 1.14 Pin functions (3 of 3)

| Function | Signal | I/O | Description |
|-----------|----------------------------|-------|-----------------------------------|
| I/O ports | P000 to P008, P010 to P015 | I/O | General-purpose input/output pins |
| | P100 to P115 | I/O | General-purpose input/output pins |
| | P200 | Input | General-purpose input pin |
| | P201 to P208, P212, P213 | I/O | General-purpose input/output pins |
| | P214, P215 | Input | General-purpose input pins |
| | P300 to P307 | I/O | General-purpose input/output pins |
| | P400 to P415 | I/O | General-purpose input/output pins |
| | P500 to P505 | I/O | General-purpose input/output pins |
| | P600 to P603, P608 to P610 | I/O | General-purpose input/output pins |
| | P708, P714 | I/O | General-purpose input/output pins |
| | P808, P809 | I/O | General-purpose input/output pins |

1.6 Pin Assignments

Figure 1.3 to Figure 1.7 show the pin assignments from the top view.

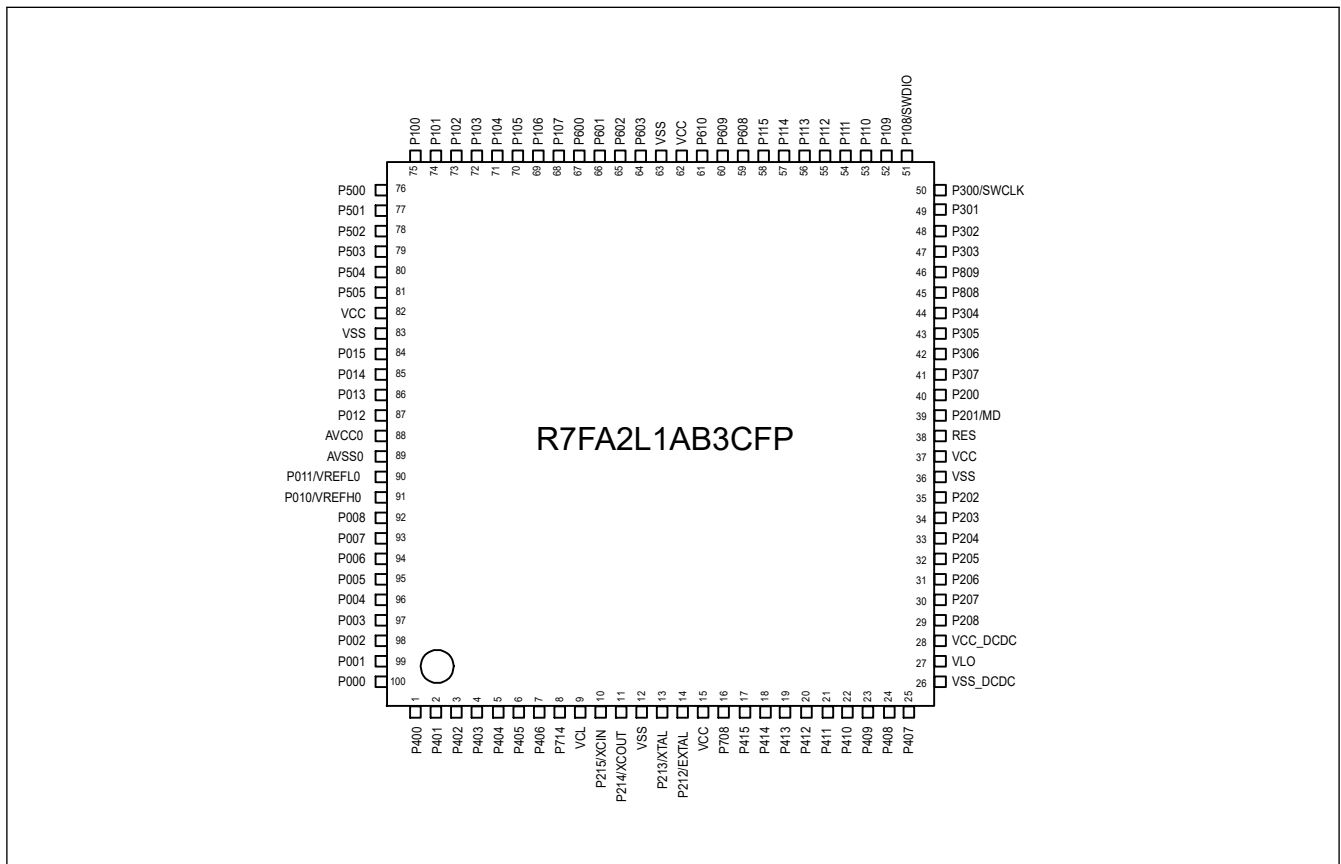

Figure 1.3 Pin assignment for LQFP 100-pin (top view)

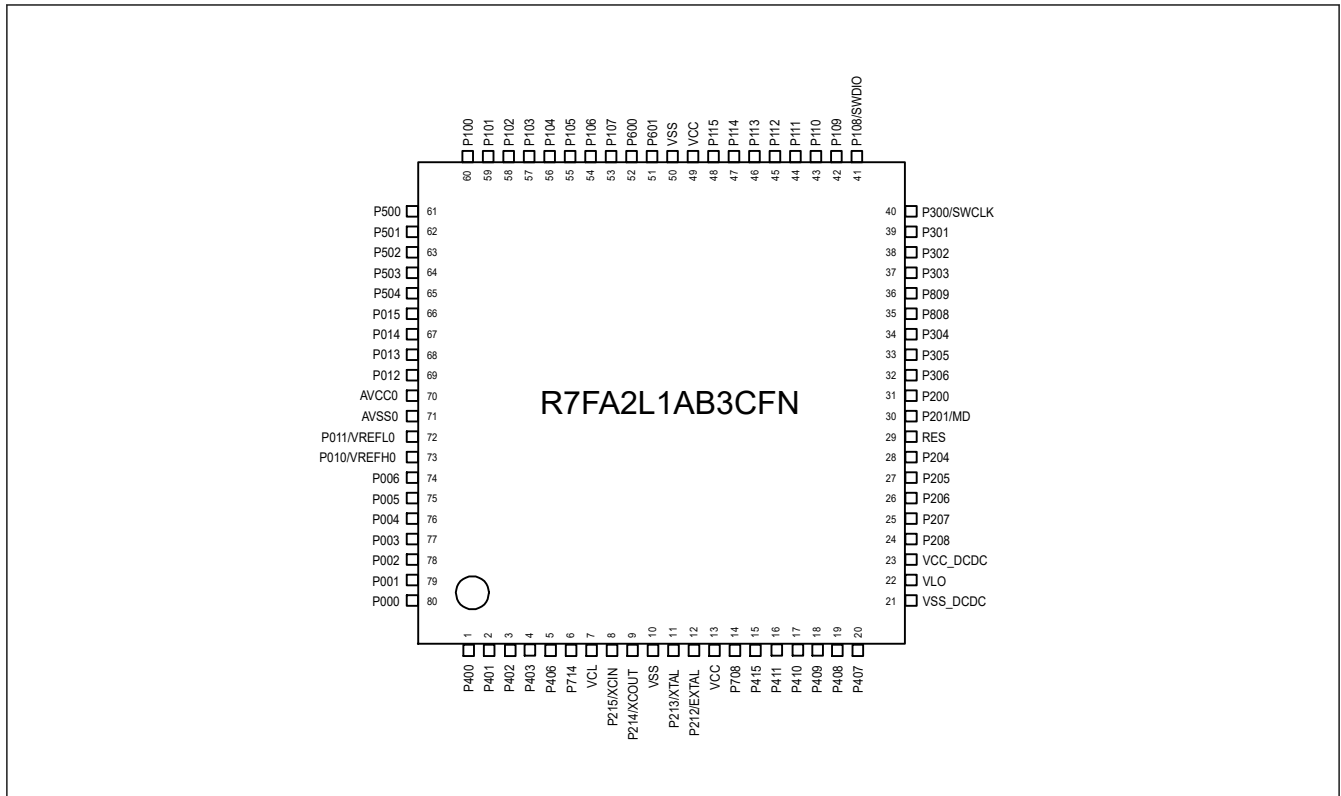

Figure 1.4 Pin assignment for LQFP 80-pin (top view)

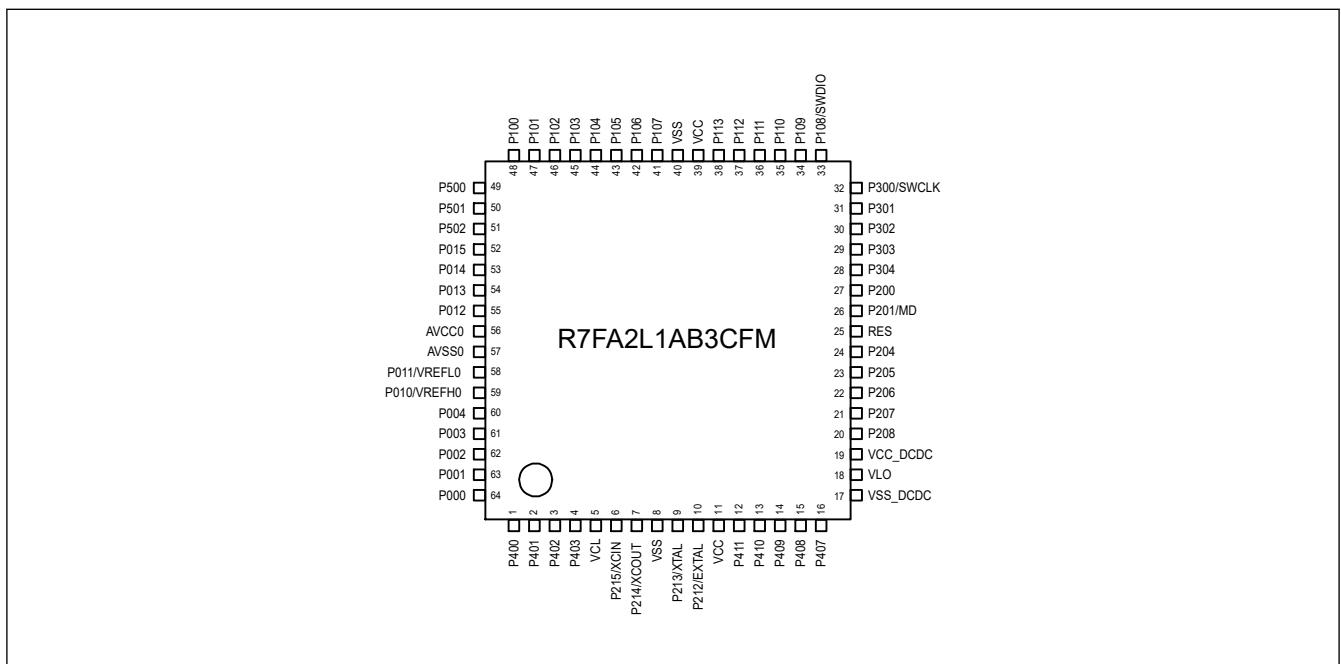

Figure 1.5 Pin assignment for LQFP 64-pin (top view)

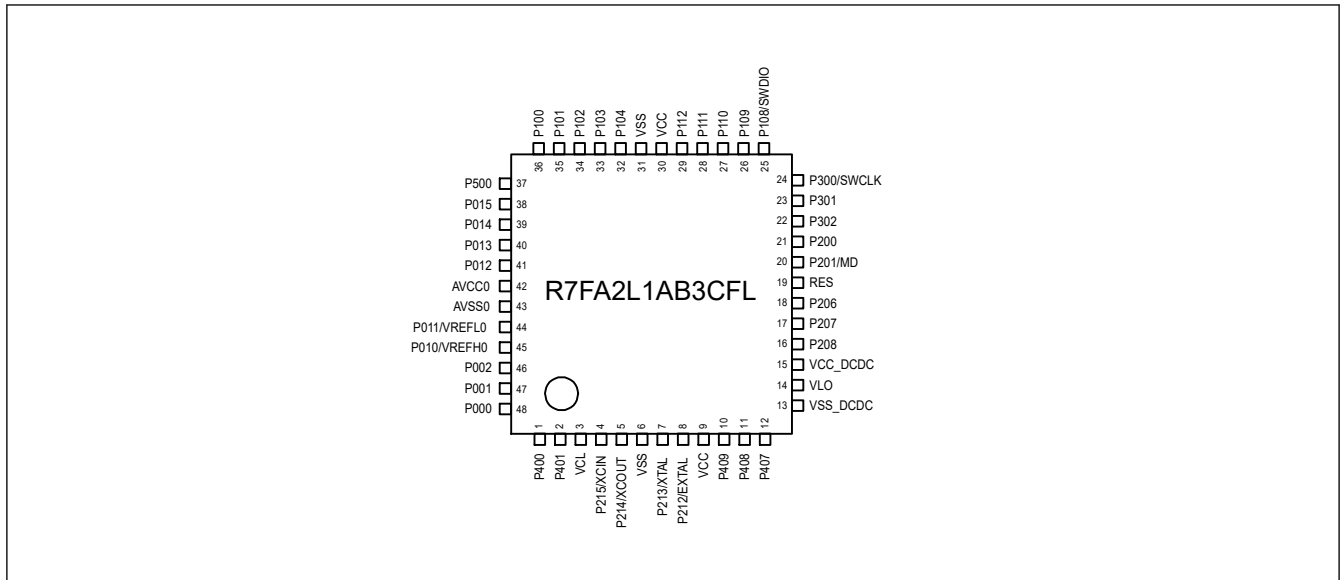

Figure 1.6 Pin assignment for LQFP 48-pin (top view)

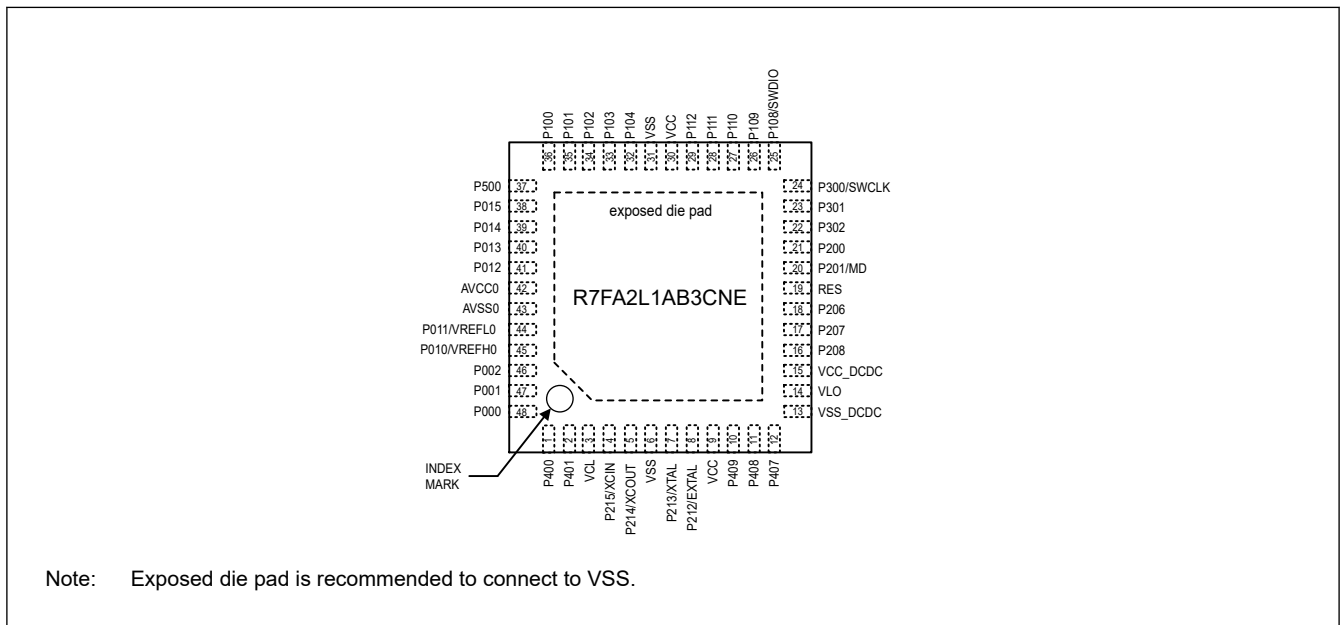

Figure 1.7 Pin assignment for QFN 48-pin (top view)

1.7 Pin Lists

Table 1.15 Pin list (1 of 4)

| Num. | | | | Power, System, Clock, Debug, CAC | I/O ports | Timers | | | | Communication interfaces | | | | Analog | | | HMI | |
|---------|--------|--------|--------------|--|-----------|-----------------------|------------------|-----------|--------|--------------------------|---|--------|----------|----------|-------|--------|--------|-----------|
| LQFP100 | LQFP80 | LQFP64 | LQFP48/QFN48 | | | AGT | GPT_OPS, POEG | GPT | RTC | CAN | SCI | IIC | SPI | ADC12 | DAC12 | ACMPLP | CTSU | Interrupt |
| 1 | 1 | 1 | 1 | CACREF_C | P400 | AGTIO1_C | — | GTIOC6A_A | — | — | SCK0_B/ SCK1_B | SCL0_A | — | — | — | — | IRQ0_A | |
| 2 | 2 | 2 | 2 | — | P401 | — | GTETRG_A_B | GTIOC6B_A | — | CTX0_B | CTS0_RT S0_B/ SS0_B/ TXD1_B/ MOSI1_B/ SDA1_B | SDA0_A | — | — | — | — | IRQ5 | |
| 3 | 3 | 3 | — | — | P402 | AGTIO0_E/ AGTIO1_D | — | — | — | CRX0_B | RXD1_B/ MISO1_B/ SCL1_B | — | — | — | — | TS18 | IRQ4 | |
| 4 | 4 | 4 | — | — | P403 | AGTIO0_F/ AGTIO1_E | — | GTIOC3A_B | — | — | CTS1_RT S1_B/ SS1_B | — | — | — | — | TS17 | — | |
| 5 | — | — | — | — | P404 | — | — | GTIOC3B_B | — | — | — | — | — | — | — | — | — | |
| 6 | — | — | — | — | P405 | — | — | GTIOC1A_B | — | — | — | — | — | — | — | — | — | |
| 7 | 5 | — | — | — | P406 | — | — | GTIOC1B_B | — | — | — | — | — | — | — | — | — | |
| 8 | 6 | — | — | — | P714 | — | — | — | — | — | — | — | — | — | — | — | — | |
| 9 | 7 | 5 | 3 | VCL | — | — | — | — | — | — | — | — | — | — | — | — | — | |
| 10 | 8 | 6 | 4 | XCIN | P215 | — | — | — | — | — | — | — | — | — | — | — | — | |
| 11 | 9 | 7 | 5 | XCOU | P214 | — | — | — | — | — | — | — | — | — | — | — | — | |
| 12 | 10 | 8 | 6 | VSS | — | — | — | — | — | — | — | — | — | — | — | — | — | |
| 13 | 11 | 9 | 7 | XTAL | P213 | — | GTETRG_A_D | GTIOC0A_D | — | — | TXD1_A/ MOSI1_A/ SDA1_A | — | — | — | — | — | IRQ2_B | |
| 14 | 12 | 10 | 8 | EXTAL | P212 | AGTEE1 | GTETRG_B_D | GTIOC0B_D | — | — | RXD1_A/ MISO1_A/ SCL1_A | — | — | — | — | — | IRQ3_B | |
| 15 | 13 | 11 | 9 | VCC | — | — | — | — | — | — | — | — | — | — | — | — | — | |
| 16 | 14 | — | — | — | P708 | — | — | — | — | — | RXD1_D/ MISO1_D /SCL1_D | — | SSLA3_B | — | — | — | — | |
| 17 | 15 | — | — | — | P415 | — | — | GTIOC0A_C | — | — | — | — | SSLA2_B | — | — | — | — | |
| 18 | — | — | — | — | P414 | — | — | GTIOC0B_C | — | — | — | — | SSLA1_B | — | — | — | — | |
| 19 | — | — | — | — | P413 | — | GTOUUP_B | — | — | — | CTS0_RT S0_E/ SS0_E | — | SSLA0_B | — | — | — | — | |
| 20 | — | — | — | — | P412 | — | GTOULO_B | — | — | — | SCK0_E | — | RSPCKA_B | — | — | — | — | |
| 21 | 16 | 12 | — | — | P411 | AGTOA1 | GTOVUP_B | GTIOC9A_A | — | — | TXD0_B/ MOSI0_B/ SDA0_B/ CTS3_RT S3_A/ SS3_A | — | MOSIA_B | — | — | — | TS07 | IRQ4_B |
| 22 | 17 | 13 | — | — | P410 | AGTOB1 | GTOVLO_B | GTIOC9B_A | — | — | RXD0_B/ MISO0_B/ SCL0_B/ SCK3_A | — | MISOA_B | — | — | — | TS06 | IRQ5_B |
| 23 | 18 | 14 | 10 | — | P409 | — | GTOVUP_B | GTIOC5A_B | — | — | TXD3_A/ MOSI3_A/ SDA3_A | — | — | — | — | — | TS05 | IRQ6_B |
| 24 | 19 | 15 | 11 | — | P408 | — | GTOVLO_B | GTIOC5B_B | — | — | CTS1_RT S1_D/ SS1_D/ RXD3_A/ MISO3_A/ SCL3_A | SCL0_C | — | — | — | — | TS04 | IRQ7_B |
| 25 | 20 | 16 | 12 | — | P407 | AGTIO0_C | — | — | RTCOUT | — | CTS0_RT S0_D/ SS0_D | SDA0_B | SSLB3_A | ADTRG0_B | — | — | — | |

Table 1.15 Pin list (2 of 4)

| Num. | | | | Power, System, Clock, Debug, CAC | I/O ports | Timers | | | | Communication interfaces | | | | Analog | | | HMI | |
|---------|--------|--------|--------------|--|-----------|--------------|------------------|---------------|-----|--------------------------|---|--------|--------------|--------|-------|--------------|--------------|-----------|
| LQFP100 | LQFP80 | LQFP64 | LQFP48/QFN48 | | | AGT | GPT_OPS, POEG | GPT | RTC | CAN | SCI | IIC | SPI | ADC12 | DAC12 | ACMPLP | CTS | Interrupt |
| 26 | 21 | 17 | 13 | VSS_DC DC | — | — | — | — | — | — | — | — | — | — | — | — | — | |
| 27 | 22 | 18 | 14 | VLO | — | — | — | — | — | — | — | — | — | — | — | — | — | |
| 28 | 23 | 19 | 15 | VCC_DC DC | — | — | — | — | — | — | — | — | — | — | — | — | — | |
| 29 | 24 | 20 | 16 | — | P208 | AGTOB0_ A | — | — | — | — | — | — | — | — | — | — | — | |
| 30 | 25 | 21 | 17 | — | P207 | — | — | — | — | — | — | — | — | — | — | — | — | |
| 31 | 26 | 22 | 18 | — | P206 | — | GTIU_A | — | — | — | RXD0_D/ MISO0_D /SCL0_D | SDA1_A | SSLB1_A | — | — | — | IRQ0 | |
| 32 | 27 | 23 | — | CLKOUT_ A | P205 | AGTO1 | GTIV_A | GTIOC4A_ B | — | — | TXD0_D/ MOSI0_D /SDA0_D/ CTS9_RT S9_A/ SS9_A | SCL1_A | SSLB0_A | — | — | — | IRQ1 | |
| 33 | 28 | 24 | — | CACREF_ A | P204 | AGTIO1_ A | GTIW_A | GTIOC4B_ B | — | — | SCK0_D/ SCK9_A | SCL0_B | RSPCKB_ A | — | — | — | TS00 | |
| 34 | — | — | — | — | P203 | — | — | — | — | — | CTS2_RT S2_A/ SS2_A/ TXD9_A/ MOSI9_A/ SDA9_A | — | MOSIB_A | — | — | — | — | |
| 35 | — | — | — | — | P202 | — | — | — | — | — | SCK2_A/ RXD9_A/ MISO9_A/ SCL9_A | — | MISOB_A | — | — | — | — | |
| 36 | — | — | — | VSS | — | — | — | — | — | — | — | — | — | — | — | — | — | |
| 37 | — | — | — | VCC | — | — | — | — | — | — | — | — | — | — | — | — | — | |
| 38 | 29 | 25 | 19 | RES | — | — | — | — | — | — | — | — | — | — | — | — | — | |
| 39 | 30 | 26 | 20 | MD | P201 | — | — | — | — | — | — | — | — | — | — | — | — | |
| 40 | 31 | 27 | 21 | — | P200 | — | — | — | — | — | — | — | — | — | — | — | NMI | |
| 41 | — | — | — | — | P307 | — | — | — | — | — | — | — | — | — | — | — | — | |
| 42 | 32 | — | — | — | P306 | — | — | — | — | — | — | — | — | — | — | — | — | |
| 43 | 33 | — | — | — | P305 | — | — | — | — | — | — | — | — | — | — | — | — | |
| 44 | 34 | 28 | — | — | P304 | — | — | GTIOC7A_ A | — | — | — | — | — | — | — | — | — | |
| 45 | 35 | — | — | — | P808 | — | — | — | — | — | — | — | — | — | — | — | — | |
| 46 | 36 | — | — | — | P809 | — | — | — | — | — | — | — | — | — | — | — | — | |
| 47 | 37 | 29 | — | — | P303 | — | — | GTIOC7B_ A | — | — | — | — | — | — | — | — | TS02- CFC | |
| 48 | 38 | 30 | 22 | — | P302 | — | GTOUUP_ A | GTIOC4A_ A | — | — | TXD2_A/ MOSI2_A/ SDA2_A | — | SSLB3_B | — | — | — | TS08- CFC | |
| 49 | 39 | 31 | 23 | — | P301 | AGTIO0_ D | GTOULO_ A | GTIOC4B_ A | — | — | RXD2_A/ MISO2_A/ SCL2_A/ CTS9_RT S9_D/ SS9_D | — | SSLB2_B | — | — | — | TS09- CFC | |
| 50 | 40 | 32 | 24 | SWCLK | P300 | — | GTOUUP_ C | GTIOC0A_ A | — | — | — | — | SSLB1_B | — | — | — | — | |
| 51 | 41 | 33 | 25 | SWDIO | P108 | — | GTOULO_ C | GTIOC0B_ A | — | — | CTS9_RT S9_B/ SS9_B | — | SSLB0_B | — | — | — | — | |
| 52 | 42 | 34 | 26 | CLKOUT_ B | P109 | — | GTOUUP_ A | GTIOC1A_ A | — | CTX0_A | SCK1_E/ TXD9_B/ MOSI9_B/ SDA9_B | — | MOSIB_B | — | — | — | TS10- CFC | |
| 53 | 43 | 35 | 27 | — | P110 | — | GTOVLO_ A | GTIOC1B_ A | — | CRX0_A | CTS2_RT S2_B/ SS2_B/ RXD9_B/ MISO9_B/ SCL9_B | — | MISOB_B | — | VCOUT | TS11- CFC | IRQ3_A | |
| 54 | 44 | 36 | 28 | — | P111 | AGTOA0 | — | GTIOC3A_ A | — | — | SCK2_B/ SCK9_B | — | RSPCKB_ B | — | — | — | TS12- CFC | |

Table 1.15 Pin list (3 of 4)

| Num. | | | | Power, System, Clock, Debug, CAC | I/O ports | Timers | | | | Communication interfaces | | | | | Analog | | | HMI | |
|---------|--------|--------|--------------|--|-----------|----------|------------------|-----------|-----|--------------------------|---|--------|----------|----------|--------|---------|----------|-----------------|--|
| LQFP100 | LQFP80 | LQFP64 | LQFP48/QFN48 | | | AGT | GPT_OPS, POEG | GPT | RTC | CAN | SCI | IIC | SPI | ADC12 | DAC12 | ACMPLP | CTS | Interrupt | |
| 55 | 45 | 37 | 29 | — | P112 | AGTOB0 | — | GTIOC3B_A | — | — | SCK1_D/ TXD2_B/ MOSI2_B/ SDA2_B | — | SSLB0_C | — | — | — | TSCAP-C | — | |
| 56 | 46 | 38 | — | — | P113 | — | — | GTIOC2A_C | — | — | — | — | — | — | — | — | TS27-CFC | — | |
| 57 | 47 | — | — | — | P114 | — | — | GTIOC2B_C | — | — | — | — | — | — | — | — | TS29-CFC | — | |
| 58 | 48 | — | — | — | P115 | — | — | GTIOC4A_C | — | — | — | — | — | — | — | — | TS35-CFC | — | |
| 59 | — | — | — | — | P608 | — | — | GTIOC4B_C | — | — | — | — | — | — | — | — | — | — | |
| 60 | — | — | — | — | P609 | — | — | GTIOC5A_C | — | — | — | — | — | — | — | — | — | — | |
| 61 | — | — | — | — | P610 | — | — | GTIOC5B_C | — | — | — | — | — | — | — | — | — | — | |
| 62 | 49 | 39 | 30 | VCC | — | — | — | — | — | — | — | — | — | — | — | — | — | — | |
| 63 | 50 | 40 | 31 | VSS | — | — | — | — | — | — | — | — | — | — | — | — | — | — | |
| 64 | — | — | — | — | P603 | — | — | GTIOC7A_B | — | — | CTS9_RT S9_C/ SS9_C | — | — | — | — | — | — | — | |
| 65 | — | — | — | — | P602 | — | — | GTIOC7B_B | — | — | TXD9_C/ MOSI9_C /SDA9_C | — | — | — | — | — | — | — | |
| 66 | 51 | — | — | — | P601 | — | — | GTIOC6A_C | — | — | RXD9_C/ MISO9_C /SCL9_C | — | — | — | — | — | — | — | |
| 67 | 52 | — | — | — | P600 | — | — | GTIOC6B_C | — | — | SCK9_C | — | — | — | — | — | — | — | |
| 68 | 53 | 41 | — | — | P107 | — | — | GTIOC8A_A | — | — | — | — | — | — | — | — | — | KR07 | |
| 69 | 54 | 42 | — | — | P106 | — | — | GTIOC8B_A | — | — | — | — | SSLA3_A | — | — | — | — | KR06 | |
| 70 | 55 | 43 | — | — | P105 | — | GTETRG_A_C | GTIOC1A_C | — | — | — | — | SSLA2_A | — | — | — | TS34-CFC | KR05/ IRQ0_B | |
| 71 | 56 | 44 | 32 | — | P104 | — | GTETRG_B_B | GTIOC1B_C | — | — | RXD0_C/ MISO0_C /SCL0_C | — | SSLA1_A | — | — | — | TS13-CFC | KR04/ IRQ1_B | |
| 72 | 57 | 45 | 33 | — | P103 | — | GTOWUP_A | GTIOC2A_A | — | CTX0_C | CTS0_RT S0_A/ SS0_A | — | SSLA0_A | — | — | CMPREF1 | TS14-CFC | KR03 | |
| 73 | 58 | 46 | 34 | — | P102 | AGTO0 | GTOWLO_A | GTIOC2B_A | — | CRX0_C | SCK0_A/ TXD2_D/ MOSI2_D /SDA2_D | — | RSPCKA_A | ADTRG0_A | — | CMPIN1 | TS15-CFC | KR02 | |
| 74 | 59 | 47 | 35 | — | P101 | AGTEE0 | GTETRG_B_A | GTIOC5A_A | — | — | TXD0_A/ MOSI0_A/ SDA0_A/ CTS1_RT S1_A/ SS1_A | SDA1_B | MOSIA_A | — | — | CMPREF0 | TS16-CFC | KR01/ IRQ1_A | |
| 75 | 60 | 48 | 36 | — | P100 | AGTIO0_A | GTETRG_A_A | GTIOC5B_A | — | — | RXD0_A/ MISO0_A/ SCL0_A/ SCK1_A | SCL1_B | MISOA_A | — | — | CMPIN0 | TS26-CFC | KR00/ IRQ2_A | |
| 76 | 61 | 49 | 37 | — | P500 | — | GTIU_B | GTIOC2A_B | — | — | — | — | — | — | — | — | — | — | |
| 77 | 62 | 50 | — | — | P501 | — | GTIV_B | GTIOC2B_B | — | — | TXD1_C/ MOSI1_C /SDA1_C | — | — | AN017 | — | — | — | — | |
| 78 | 63 | 51 | — | — | P502 | — | GTIW_B | GTIOC3B_C | — | — | RXD1_C/ MISO1_C /SCL1_C | — | — | AN018 | — | — | — | — | |
| 79 | 64 | — | — | — | P503 | — | GTETRG_A_E | — | — | — | SCK1_C | — | — | AN019 | — | — | — | — | |
| 80 | 65 | — | — | — | P504 | — | GTETRG_B_E | — | — | — | CTS1_RT S1_C/ SS1_C | — | — | AN020 | — | — | — | — | |
| 81 | — | — | — | — | P505 | — | — | — | — | — | — | — | — | — | — | — | — | — | |
| 82 | — | — | — | VCC | — | — | — | — | — | — | — | — | — | — | — | — | — | — | |

Table 1.15 Pin list (4 of 4)

| Num. | | | | Power, System, Clock, Debug, CAC | I/O ports | Timers | | | | Communication interfaces | | | | Analog | | | HMI | |
|---------|--------|--------|--------------|--|-----------|--------|------------------|-----|-----|--------------------------|-----|-----|-------|--------|-------|----------|--------|-----------|
| LQFP100 | LQFP80 | LQFP64 | LQFP48/QFN48 | | | AGT | GPT_OPS, POEG | GPT | RTC | CAN | SCI | IIC | SPI | ADC12 | DAC12 | ACMPLP | CTS | Interrupt |
| 83 | — | — | — | VSS | — | — | — | — | — | — | — | — | — | — | — | — | — | |
| 84 | 66 | 52 | 38 | — | P015 | — | — | — | — | — | — | — | AN010 | — | — | TS28-CFC | IRQ7_A | |
| 85 | 67 | 53 | 39 | — | P014 | — | — | — | — | — | — | — | AN009 | DA0 | — | — | — | |
| 86 | 68 | 54 | 40 | — | P013 | — | — | — | — | — | — | — | AN008 | — | — | TS33-CFC | — | |
| 87 | 69 | 55 | 41 | — | P012 | — | — | — | — | — | — | — | AN007 | — | — | TS32-CFC | — | |
| 88 | 70 | 56 | 42 | AVCC0 | — | — | — | — | — | — | — | — | — | — | — | — | — | |
| 89 | 71 | 57 | 43 | AVSS0 | — | — | — | — | — | — | — | — | — | — | — | — | — | |
| 90 | 72 | 58 | 44 | VREFL0 | P011 | — | — | — | — | — | — | — | AN006 | — | — | TS31-CFC | — | |
| 91 | 73 | 59 | 45 | VREFH0 | P010 | — | — | — | — | — | — | — | AN005 | — | — | TS30-CFC | — | |
| 92 | — | — | — | — | P008 | — | — | — | — | — | — | — | AN014 | — | — | — | — | |
| 93 | — | — | — | — | P007 | — | — | — | — | — | — | — | AN013 | — | — | — | — | |
| 94 | 74 | — | — | — | P006 | — | — | — | — | — | — | — | AN012 | — | — | — | — | |
| 95 | 75 | — | — | — | P005 | — | — | — | — | — | — | — | AN011 | — | — | — | — | |
| 96 | 76 | 60 | — | — | P004 | — | — | — | — | — | — | — | AN004 | — | — | TS25 | IRQ3 | |
| 97 | 77 | 61 | — | — | P003 | — | — | — | — | — | — | — | AN003 | — | — | TS24 | — | |
| 98 | 78 | 62 | 46 | — | P002 | — | — | — | — | — | — | — | AN002 | — | — | TS23 | IRQ2 | |
| 99 | 79 | 63 | 47 | — | P001 | — | — | — | — | — | — | — | AN001 | — | — | TS22 | IRQ7 | |
| 100 | 80 | 64 | 48 | — | P000 | — | — | — | — | — | — | — | AN000 | — | — | TS21 | IRQ6 | |

Note: Several pin names have the added suffix of _A, _B, _C, _D, _E and _F. The suffix can be ignored when assigning functionality.

2. Electrical Characteristics

Unless otherwise specified, the electrical characteristics of the MCU are defined under the following conditions:

$$VCC^{*1} = AVCC0 = VCC_DCDC^{*2} = 1.6 \text{ to } 5.5 \text{ V}, VREFH0 = 1.6 \text{ V to } AVCC0$$

$$VSS = AVSS0 = VREFL0 = 0 \text{ V}, T_a = T_{opr}$$

Note 1. The typical condition is set to $VCC = 3.3 \text{ V}$.

Note 2. When VCC_DCDC is used. $VCC = AVCC0 = VCC_DCDC = 2.4 \text{ to } 5.5 \text{ V}$.

Figure 2.1 shows the timing conditions.

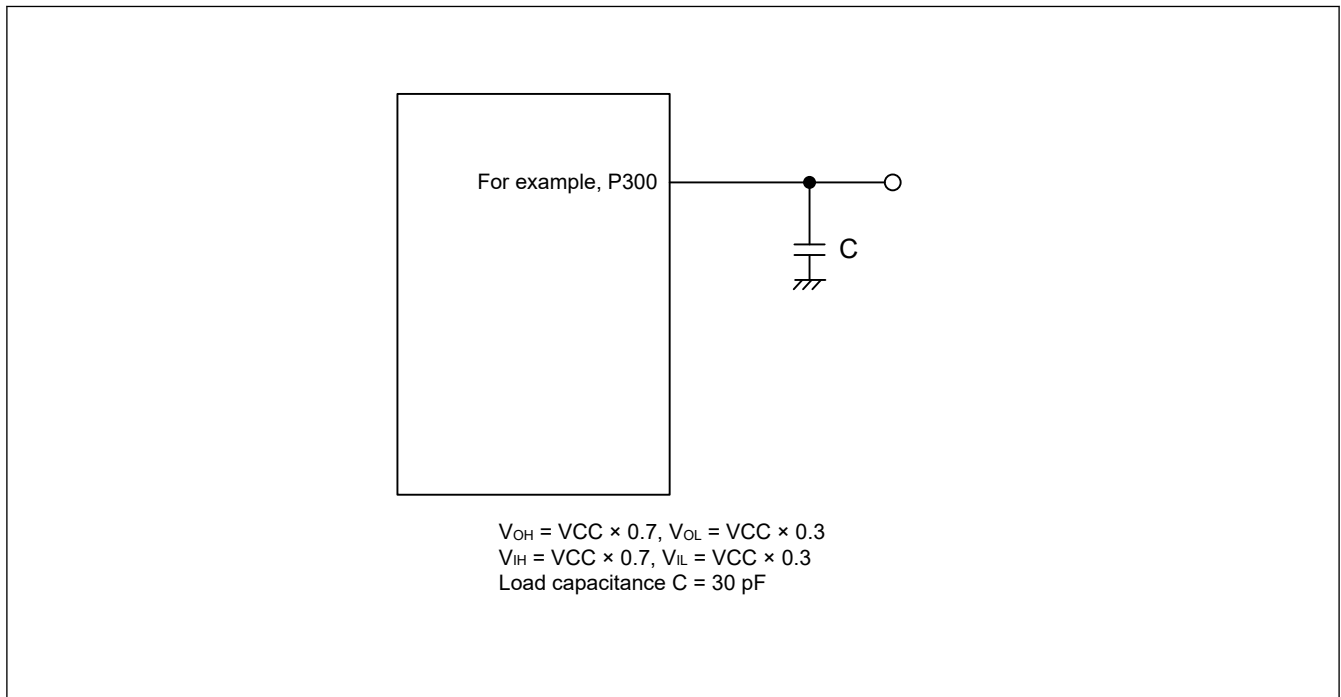

Figure 2.1 Input or output timing measurement conditions

The measurement conditions of the timing specifications for each peripheral are recommended for the best peripheral operation. However, make sure to adjust driving abilities for each pin to meet the conditions of your system.

Each function pin used for the same function must select the same drive ability. If the I/O drive ability of each function pin is mixed, the AC characteristics of each function are not guaranteed.

2.1 Absolute Maximum Ratings

Table 2.1 Absolute maximum ratings (1 of 2)

| Parameter | Symbol | Value | Unit | |
|--|------------------------------|--------------|---------------------|---|
| Power supply voltage | VCC | -0.5 to +6.5 | V | |
| Input voltage | 5V-tolerant ports*1 | V_{in} | -0.3 to +6.5 | V |
| | P000 to P008, P010 to P015 | V_{in} | -0.3 to AVCC0 + 0.3 | V |
| | Others | V_{in} | -0.3 to VCC + 0.3 | V |
| Reference power supply voltage | VREFH0 | -0.3 to +6.5 | V | |
| Analog power supply voltage | AVCC0 | -0.5 to +6.5 | V | |
| Switching regulator power supply voltage | VCC_DCDC | -0.5 to +6.5 | V | |
| Analog input voltage | When AN000 to AN014 are used | V_{AN} | -0.3 to AVCC0 + 0.3 | V |
| | When AN017 to AN020 are used | | -0.3 to VCC + 0.3 | V |

Table 2.1 Absolute maximum ratings (2 of 2)

| Parameter | Symbol | Value | Unit |
|--------------------------------|------------------|---------------------------|------|
| Operating temperature *2 *3 *4 | T _{opr} | -40 to +85 -40 to +105 | °C |
| Storage temperature | T _{stg} | -55 to +125 | °C |

Note 1. Ports P205, P206, P400, P401, and P407 are 5V-tolerant.

Do not input signals or an I/O pull-up power supply while the device is not powered. The current injection that results from input of such a signal or I/O pull-up might cause malfunction and the abnormal current that passes in the device at this time might cause degradation of internal elements.

Note 2. See [section 2.2.1. Tj/Ta Definition](#).

Note 3. Contact Renesas Electronics sales office for information on derating operation under Ta = +85°C to +105°C. Derating is the systematic reduction of load for improved reliability.

Note 4. The upper limit of the operating temperature is 85°C or 105°C, depending on the product.

Caution: Permanent damage to the MCU may result if absolute maximum ratings are exceeded.

To preclude any malfunctions due to noise interference, insert capacitors with high frequency characteristics between the VCC and VSS pins, between the AVCC0 and AVSS0 pins, and between the VREFH0 and VREFL0 pins when VREFH0 is selected as the high potential reference voltage for the ADC12. Place capacitors of the following value as close as possible to every power supply pin and use the shortest and heaviest possible traces:

- VCC and VSS: about 0.1 μF
- AVCC0 and AVSS0: about 0.1 μF
- VREFH0 and VREFL0: about 0.1 μF

Also, connect capacitors as stabilization capacitance.

Connect the VCL pin to a VSS pin by a 4.7 μF capacitor. Connect the VCC_DCDC pin to a VSS_DCDC pin by a 1.0 μF capacitor. Each capacitor must be placed close to the pin.

Table 2.2 Recommended operating conditions

| Parameter | Symbol | Min | Typ | Max | Unit | |
|--|------------|------------------------------|-----|-----|-------|---|
| Power supply voltages | VCC*1 *2 | 1.6 | — | 5.5 | V | |
| | VSS | — | 0 | — | V | |
| Switching regulator power supply voltage | VCC_DCDC | VCC_DCDC = VCC | 2.4 | — | 5.5 | V |
| Analog power supply voltages | AVCC0*1 *2 | 1.6 | — | 5.5 | V | |
| | AVSS0 | — | 0 | — | V | |
| | VREFH0 | When used as ADC12 Reference | 1.6 | — | AVCC0 | V |
| | VREFL0 | | — | 0 | — | V |

Note 1. Use AVCC0 and VCC under the following conditions:
AVCC0 = VCC

Note 2. When powering on the VCC and AVCC0 pins, power them on at the same time or the VCC pin first and then the AVCC0 pins. When powering off the VCC and AVCC0 pins, power them off at the same time or the AVCC0 pin first and then the VCC pins.

2.2 DC Characteristics

2.2.1 Tj/Ta Definition

Table 2.3 DC characteristics

Conditions: Products with operating temperature (Ta) -40 to +105°C

| Parameter | Symbol | Typ | Max | Unit | Test conditions |
|----------------------------------|--------|-----|-------|------|---|
| Permissible junction temperature | Tj | — | 125 | °C | High-speed mode Middle-speed mode Low-speed mode Subosc-speed mode |
| | | | 105*1 | | |

Note: Make sure that $T_j = T_a + \theta_{ja} \times \text{total power consumption (W)}$, where total power consumption = $(V_{CC} - V_{OH}) \times \Sigma I_{OH} + V_{OL} \times \Sigma I_{OL} + I_{CCmax} \times V_{CC}$.

Note 1. The upper limit of operating temperature is 85°C or 105°C, depending on the product. If the part number shows the operation temperature at 85°C, then the maximum value of Tj is 105°C, otherwise it is 125°C.

2.2.2 I/O V_{IH} , V_{IL} Table 2.4 I/O V_{IH} , V_{IL} Conditions: $V_{CC} = AV_{CC0} = 1.6$ to 5.5 V

| Parameter | Symbol | Min | Typ | Max | Unit | Test Conditions | |
|---|---|--------------|-----------------------|-----|-----------------------|------------------------------|---|
| Schmitt trigger input voltage | IIC (except for SMBus)* ¹ | V_{IH} | $V_{CC} \times 0.7$ | — | 5.8 | V | — |
| | | V_{IL} | — | — | $V_{CC} \times 0.3$ | | |
| | | ΔV_T | $V_{CC} \times 0.10$ | — | — | | |
| | | | $V_{CC} \times 0.05$ | — | — | | |
| | RES, NMI Other peripheral input pins excluding IIC | V_{IH} | $V_{CC} \times 0.8$ | — | — | | — |
| | | V_{IL} | — | — | $V_{CC} \times 0.2$ | | |
| | | ΔV_T | $V_{CC} \times 0.10$ | — | — | | |
| | | | $V_{CC} \times 0.05$ | — | — | | |
| Input voltage (except for Schmitt trigger input pin) | IIC (SMBus)* ² | V_{IH} | 2.2 | — | — | $V_{CC} = 3.6$ to 5.5 V | |
| | | V_{IH} | 2.0 | — | — | $V_{CC} = 2.7$ to 3.6 V | |
| | | V_{IL} | — | — | 0.8 | $V_{CC} = 3.6$ to 5.5 V | |
| | | V_{IL} | — | — | 0.5 | $V_{CC} = 2.7$ to 3.6 V | |
| | 5V-tolerant ports* ³ | V_{IH} | $V_{CC} \times 0.8$ | — | 5.8 | — | |
| | | V_{IL} | — | — | $V_{CC} \times 0.2$ | | |
| | P000 to P008, P010 to P015 | V_{IH} | $AV_{CC0} \times 0.8$ | — | — | | |
| | | V_{IL} | — | — | $AV_{CC0} \times 0.2$ | | |
| | EXTAL Input ports pins except for P000 to P008, P010 to P015 | V_{IH} | $V_{CC} \times 0.8$ | — | — | | |
| | | V_{IL} | — | — | $V_{CC} \times 0.2$ | | |

Note 1. SCL0_A, SDA0_A, SDA0_B, SCL1_A, SDA1_A (total 5 pins)

Note 2. SCL0_A, SCL0_B, SCL0_C, SDA0_A, SDA0_B, SCL1_A, SCL1_B, SDA1_A, SDA1_B (total 9 pins)

Note 3. P205, P206, P400, P401, P407 (total 5 pins)

2.2.3 I/O I_{OH} , I_{OL} Table 2.5 I/O I_{OH} , I_{OL} (1 of 6)Conditions: $V_{CC} = AV_{CC0} = 1.6$ to 5.5 V

| Parameter | Symbol | Min | Typ | Max | Unit | Test conditions |
|--|--|----------|-----|-----|------|-----------------|
| Permissible output current (average value per pin) | Ports P000 to P008, P010 to P015, P205, P206, P212, P213, P400, P401, P407 | I_{OH} | — | — | -4.0 | mA |
| | | I_{OL} | — | — | 8.0 | mA |
| | Other output pins* ¹ | I_{OH} | — | — | -4.0 | mA |
| | | I_{OL} | — | — | 20.0 | mA |

Table 2.5 I/O I_{OH} , I_{OL} (2 of 6)

Conditions: VCC = AVCC0 = 1.6 to 5.5 V

| Parameter | | Symbol | Min | Typ | Max | Unit | Test conditions | |
|---|--|---------------------------|-----------------------|-----|------|--------------------|----------------------|--------------------|
| Permissible output current (max value per pin) | Ports P000 to P008, P010 to P015, P205, P206, P212, P213, P400, P401, P407 | I_{OH} | — | — | -4.0 | mA | | |
| | | I_{OL} | — | — | 8.0 | mA | | |
| | Other output pins* ¹ | I_{OH} | — | — | -4.0 | mA | | |
| | | I_{OL} | — | — | 20.0 | mA | | |
| Permissible output current (max value total pins)* ² | Total of ports P000 to P008, P010 to P015 | $\Sigma I_{OH} (max)$ | — | — | -30 | mA | AVCC0 = 2.7 to 5.5 V | |
| | | | — | — | -8 | mA | AVCC0 = 1.8 to 2.7 V | |
| | | | — | — | -4 | mA | AVCC0 = 1.6 to 1.8 V | |
| | | $\Sigma I_{OL} (max)$ | — | — | 50 | mA | AVCC0 = 2.7 to 5.5 V | |
| | | | — | — | 4 | mA | AVCC0 = 1.8 to 2.7 V | |
| | | | — | — | 2 | mA | AVCC0 = 1.6 to 1.8 V | |
| | | Total of ports P212, P213 | ΣI_{OH} | — | — | -8.0 | mA | VCC = 2.7 to 5.5 V |
| | | | | — | — | -2 | mA | VCC = 1.8 to 2.7 V |
| | | | | — | — | -1 | mA | VCC = 1.6 to 1.8 V |
| | ΣI_{OL} | | — | — | 16.0 | mA | VCC = 2.7 to 5.5 V | |
| | | | — | — | 1.2 | mA | VCC = 1.8 to 2.7 V | |
| | | | — | — | 0.6 | mA | VCC = 1.6 to 1.8 V | |
| | Total of ports P400 to P415, P708, P714 | 100 pin products | $\Sigma I_{OH} (max)$ | — | — | -30 | mA | VCC = 2.7 to 5.5 V |
| | | | | — | — | -8 | mA | VCC = 1.8 to 2.7 V |
| | | | | — | — | -4 | mA | VCC = 1.6 to 1.8 V |
| | | $\Sigma I_{OL} (max)$ | — | — | 50 | mA | VCC = 2.7 to 5.5 V | |
| — | | | — | 4 | mA | VCC = 1.8 to 2.7 V | | |
| — | | | — | 2 | mA | VCC = 1.6 to 1.8 V | | |

Table 2.5 I/O I_{OH} , I_{OL} (3 of 6)

Conditions: VCC = AVCC0 = 1.6 to 5.5 V

| Parameter | | | Symbol | Min | Typ | Max | Unit | Test conditions |
|---|---|----------------------|----------------------|-----|-----|-----|--------------------|--------------------|
| Permissible output current (max value total pins) ^{*2} | Total of ports P201 to P208, P303 to P307, P808, P809 | 100 pin products | $\Sigma I_{OH(max)}$ | — | — | -30 | mA | VCC = 2.7 to 5.5 V |
| | | | | — | — | -8 | mA | VCC = 1.8 to 2.7 V |
| | | | | — | — | -4 | mA | VCC = 1.6 to 1.8 V |
| | | | $\Sigma I_{OL(max)}$ | — | — | 50 | mA | VCC = 2.7 to 5.5 V |
| | | | | — | — | 4 | mA | VCC = 1.8 to 2.7 V |
| | | | | — | — | 2 | mA | VCC = 1.6 to 1.8 V |
| | Total of ports P108 to P115, P300 to P302, P600 to P603, P608 to P610 | 100 pin products | $\Sigma I_{OH(max)}$ | — | — | -30 | mA | VCC = 2.7 to 5.5 V |
| | | | | — | — | -8 | mA | VCC = 1.8 to 2.7 V |
| | | | | — | — | -4 | mA | VCC = 1.6 to 1.8 V |
| | | | $\Sigma I_{OL(max)}$ | — | — | 50 | mA | VCC = 2.7 to 5.5 V |
| | | | | — | — | 4 | mA | VCC = 1.8 to 2.7 V |
| | | | | — | — | 2 | mA | VCC = 1.6 to 1.8 V |
| Total of ports P100 to P107, P500 to P505 | 100 pin products | $\Sigma I_{OH(max)}$ | — | — | -30 | mA | VCC = 2.7 to 5.5 V | |
| | | | — | — | -8 | mA | VCC = 1.8 to 2.7 V | |
| | | | — | — | -4 | mA | VCC = 1.6 to 1.8 V | |
| | | $\Sigma I_{OL(max)}$ | — | — | 50 | mA | VCC = 2.7 to 5.5 V | |
| | | | — | — | 4 | mA | VCC = 1.8 to 2.7 V | |
| | | | — | — | 2 | mA | VCC = 1.6 to 1.8 V | |

Table 2.5 I/O I_{OH} , I_{OL} (4 of 6)

Conditions: VCC = AVCC0 = 1.6 to 5.5 V

| Parameter | | | Symbol | Min | Typ | Max | Unit | Test conditions |
|---|---|-----------------------|-----------------------|-----|-----|------|------|--------------------|
| Permissible output current (max value total pins) ^{*2} | Total of all output pin | 100 pin products | $\Sigma I_{OH} (max)$ | — | — | -100 | mA | |
| | | | $\Sigma I_{OL} (max)$ | — | — | 100 | mA | |
| | Total of ports P204 to P208, P400 to P403, P406 to P411, P415, P708, P714 | 80 pin products | $\Sigma I_{OH} (max)$ | — | — | -30 | mA | VCC = 2.7 to 5.5 V |
| | | | | — | — | -8 | mA | VCC = 1.8 to 2.7 V |
| | | | | — | — | -4 | mA | VCC = 1.6 to 1.8 V |
| | | | $\Sigma I_{OL} (max)$ | — | — | 50 | mA | VCC = 2.7 to 5.5 V |
| | | | | — | — | 4 | mA | VCC = 1.8 to 2.7 V |
| | | | | — | — | 2 | mA | VCC = 1.6 to 1.8 V |
| | Total of ports P100 to P115, P201, P300 to P306, P500 to P504, P600, P601, P808, P809 | 80 pin products | $\Sigma I_{OH} (max)$ | — | — | -30 | mA | VCC = 2.7 to 5.5 V |
| | | | | — | — | -8 | mA | VCC = 1.8 to 2.7 V |
| | | | | — | — | -4 | mA | VCC = 1.6 to 1.8 V |
| | | | $\Sigma I_{OL} (max)$ | — | — | 50 | mA | VCC = 2.7 to 5.5 V |
| | | | | — | — | 4 | mA | VCC = 1.8 to 2.7 V |
| | | | | — | — | 2 | mA | VCC = 1.6 to 1.8 V |
| Total of all output pin | 80 pin products | $\Sigma I_{OH} (max)$ | — | — | -60 | mA | | |
| | | $\Sigma I_{OL} (max)$ | — | — | 100 | mA | | |

Table 2.5 I/O I_{OH} , I_{OL} (5 of 6)

Conditions: VCC = AVCC0 = 1.6 to 5.5 V

| Parameter | | | Symbol | Min | Typ | Max | Unit | Test conditions |
|---|---|----------------------|----------------------|-----|-----|-----|------|--------------------|
| Permissible output current (max value total pins) ^{*2} | Total of ports P204 to P208, P400 to P403, P407 to P411 | 64 pin products | $\Sigma I_{OH(max)}$ | — | — | -30 | mA | VCC = 2.7 to 5.5 V |
| | | | | — | — | -8 | mA | VCC = 1.8 to 2.7 V |
| | | | | — | — | -4 | mA | VCC = 1.6 to 1.8 V |
| | | | $\Sigma I_{OL(max)}$ | — | — | 50 | mA | VCC = 2.7 to 5.5 V |
| | | | | — | — | 4 | mA | VCC = 1.8 to 2.7 V |
| | | | | — | — | 2 | mA | VCC = 1.6 to 1.8 V |
| | Total of ports P100 to P113, P201, P300 to P304, P500 to P502 | 64 pin products | $\Sigma I_{OH(max)}$ | — | — | -30 | mA | VCC = 2.7 to 5.5 V |
| | | | | — | — | -8 | mA | VCC = 1.8 to 2.7 V |
| | | | | — | — | -4 | mA | VCC = 1.6 to 1.8 V |
| | | | $\Sigma I_{OL(max)}$ | — | — | 50 | mA | VCC = 2.7 to 5.5 V |
| | | | | — | — | 4 | mA | VCC = 1.8 to 2.7 V |
| | | | | — | — | 2 | mA | VCC = 1.6 to 1.8 V |
| Total of all output pin | 64 pin products | $\Sigma I_{OH(max)}$ | — | — | -60 | mA | | |
| | | $\Sigma I_{OL(max)}$ | — | — | 100 | mA | | |

Table 2.5 I/O I_{OH}, I_{OL} (6 of 6)

Conditions: VCC = AVCC0 = 1.6 to 5.5 V

| Parameter | | | Symbol | Min | Typ | Max | Unit | Test conditions |
|---|---|------------------------|------------------------|-----|-----|-----|------|--------------------|
| Permissible output current (max value total pins)*2 | Total of ports P206 to P208, P400, P401, P407 to P409 | 48 pin products | ΣI _{OH} (max) | — | — | -30 | mA | VCC = 2.7 to 5.5 V |
| | | | | — | — | -8 | mA | VCC = 1.8 to 2.7 V |
| | | | | — | — | -4 | mA | VCC = 1.6 to 1.8 V |
| | | 48 pin products | ΣI _{OL} (max) | — | — | 50 | mA | VCC = 2.7 to 5.5 V |
| | | | | — | — | 4 | mA | VCC = 1.8 to 2.7 V |
| | | | | — | — | 2 | mA | VCC = 1.6 to 1.8 V |
| | Total of ports P100 to P104, P108 to P112, P201, P300 to P302, P500 | 48 pin products | ΣI _{OH} (max) | — | — | -30 | mA | VCC = 2.7 to 5.5 V |
| | | | | — | — | -8 | mA | VCC = 1.8 to 2.7 V |
| | | | | — | — | -4 | mA | VCC = 1.6 to 1.8 V |
| | | 48 pin products | ΣI _{OL} (max) | — | — | 50 | mA | VCC = 2.7 to 5.5 V |
| | | | | — | — | 4 | mA | VCC = 1.8 to 2.7 V |
| | | | | — | — | 2 | mA | VCC = 1.6 to 1.8 V |
| Total of all output pin | 48 pin products | ΣI _{OH} (max) | — | — | -60 | mA | | |
| | | ΣI _{OL} (max) | — | — | 100 | mA | | |

Note 1. Except for Ports P200, P214, and P215, which are input ports.

Note 2. Specification under conditions where the duty factor ≤ 70%.

The output current value that has changed to the duty factor > 70% the duty ratio can be calculated with the following expression (when changing the duty factor from 70% to n%).

$$\text{Total output current of pins} = (I_{OH} \times 0.7) / (n \times 0.01)$$

<Example> Where n = 80% and I_{OH} = -30.0 mA

$$\text{Total output current of pins} = (-30.0 \times 0.7) / (80 \times 0.01) \cong -26.2 \text{ mA}$$

However, the current that is allowed to flow into one pin does not vary depending on the duty factor.

Caution: To protect the reliability of the MCU, the output current values should not exceed the values in Table 2.5.

2.2.4 I/O V_{OH}, V_{OL}, and Other Characteristics

Table 2.6 I/O V_{OH}, V_{OL} (1)

Conditions: VCC = AVCC0 = 4.0 to 5.5 V

| Parameter | | Symbol | Min | Typ | Max | Unit | Test conditions |
|----------------|---|-----------------|-------------|-----|-----|------|---------------------------|
| Output voltage | Ports P000 to P008, P010 to P015 | V _{OH} | AVCC0 - 0.8 | — | — | V | I _{OH} = -4.0 mA |
| | Output pins except for P000 to P008 and P010 to P015*1 | V _{OH} | VCC - 0.8 | — | — | | I _{OH} = -4.0 mA |
| | Ports P000 to P008, P010 to P015 | V _{OL} | — | — | 0.8 | | I _{OL} = 8.0 mA |
| | Ports P205, P206, P212, P213, P400, P401, P407 | V _{OL} | — | — | 0.8 | | I _{OL} = 8.0 mA |
| | Output pins except for P000 to P008, P010 to P015, P205, P206, P212, P213, P400, P401, and P407*1 | V _{OL} | — | — | 1.2 | | I _{OL} = 20.0 mA |

Note 1. Except for Ports P200, P214, and P215, which are input ports.

Table 2.7 I/O V_{OH} , V_{OL} (2)

Conditions: $V_{CC} = AV_{CC0} = 2.7$ to 4.0 V

| Parameter | | Symbol | Min | Typ | Max | Unit | Test conditions |
|----------------|--|----------|------------------|-----|-----|------|--------------------|
| Output voltage | Ports P000 to P008, P010 to P015 | V_{OH} | $AV_{CC0} - 0.8$ | — | — | V | $I_{OH} = -4.0$ mA |
| | Output pins except for P000 to P008 and P010 to P015 ^{*1} | V_{OH} | $V_{CC} - 0.8$ | — | — | | $I_{OH} = -4.0$ mA |
| | Ports P000 to P008, P010 to P015 | V_{OL} | — | — | 0.8 | | $I_{OL} = 8.0$ mA |
| | Output pins except for P000 to P008 and P010 to P015 ^{*1} | V_{OL} | — | — | 0.8 | | $I_{OL} = 8.0$ mA |

Note 1. Except for Ports P200, P214, and P215, which are input ports.

Table 2.8 I/O V_{OH} , V_{OL} (3)

Conditions: $V_{CC} = AV_{CC0} = 1.6$ to 2.7 V

| Parameter | | Symbol | Min | Typ | Max | Unit | Test conditions |
|----------------|--|----------|------------------|-----|-----|------|---|
| Output voltage | Ports P000 to P008, P010 to P015 | V_{OH} | $AV_{CC0} - 0.5$ | — | — | V | $I_{OH} = -1.0$ mA $AV_{CC0} = 1.8$ to 2.7 V |
| | | | $AV_{CC0} - 0.5$ | — | — | | $I_{OH} = -0.5$ mA $AV_{CC0} = 1.6$ to 1.8 V |
| | Output pins except for P000 to P008 and P010 to P015 ^{*1} | V_{OH} | $V_{CC} - 0.5$ | — | — | | $I_{OH} = -1.0$ mA $V_{CC} = 1.8$ to 2.7 V |
| | | | $V_{CC} - 0.5$ | — | — | | $I_{OH} = -0.5$ mA $V_{CC} = 1.6$ to 1.8 V |
| | Ports P000 to P008, P010 to P015 | V_{OL} | — | — | 0.4 | | $I_{OL} = 0.6$ mA $AV_{CC0} = 1.8$ to 2.7 V |
| | | | — | — | 0.4 | | $I_{OL} = 0.3$ mA $AV_{CC0} = 1.6$ to 1.8 V |
| | Output pins except for P000 to P008 and P010 to P015 ^{*1} | V_{OL} | — | — | 0.4 | | $I_{OL} = 0.6$ mA $V_{CC} = 1.8$ to 2.7 V |
| | | | — | — | 0.4 | | $I_{OL} = 0.3$ mA $V_{CC} = 1.6$ to 1.8 V |

Note 1. Except for Ports P200, P214, and P215, which are input ports.

Table 2.9 I/O other characteristics

Conditions: $V_{CC} = AV_{CC0} = 1.6$ to 5.5 V

| Parameter | | Symbol | Min | Typ | Max | Unit | Test conditions |
|---|--|-------------|-----|-----|-----|------------|---|
| Input leakage current | RES, ports P200, P214, P215 | $ I_{in} $ | — | — | 1.0 | μ A | $V_{in} = 0$ V $V_{in} = V_{CC}$ |
| Three-state leakage current (off state) | 5V-tolerant ports ^{*1} | $ I_{TSI} $ | — | — | 1.0 | μ A | $V_{in} = 0$ V $V_{in} = 5.8$ V |
| | Other ports (except for P200, P214, P215, and 5V-tolerant ports) | | — | — | 1.0 | | $V_{in} = 0$ V $V_{in} = V_{CC}$ |
| Input pull-up resistor | All ports (except for P200, P214, P215) | R_U | 10 | 20 | 100 | k Ω | $V_{in} = 0$ V |
| Input capacitance | P200 | C_{in} | — | — | 30 | pF | $V_{in} = 0$ V $f = 1$ MHz $T_a = 25^\circ$ C |
| | Other input pins | | — | — | 15 | | |

Note 1. P205, P206, P400, P401, and P407 (total 5 pins)

2.2.5 Operating and Standby Current

Table 2.10 Operating and standby current (1) (1 of 2)

Conditions: VCC = AVCC0 = 1.6 to 5.5 V

| Parameter | | | | Symbol | LDO mode | | DCDC mode ^{*12} | | Unit | Test Conditions | | | | |
|------------------------------|---------------------------------|---|--|---------------|--------------------|--|--------------------------|------|------|-----------------|--------|------|----|----|
| | | | | | Typ ^{*10} | Max | Typ ^{*10} | Max | | | | | | |
| Supply current ^{*1} | High-speed mode ^{*2} | Normal mode | All peripheral clocks disabled, CoreMark code executing from flash ^{*5} | ICLK = 48 MHz | I _{CC} | 5.50 | — | 3.05 | — | mA | *7 *11 | | | |
| | | | | ICLK = 32 MHz | | 3.65 | — | 2.20 | — | | *7 | | | |
| | | | | ICLK = 16 MHz | | 2.20 | — | 1.35 | — | | | | | |
| | | | | ICLK = 8 MHz | | 1.45 | — | 0.90 | — | | | | | |
| | | | All peripheral clocks enabled, code executing from flash ^{*5} | ICLK = 48 MHz | | — | 14.5 | — | 12.5 | | *9 *11 | | | |
| | | | | Sleep mode | | All peripheral clocks disabled ^{*5} | ICLK = 48 MHz | 1.05 | — | | 0.65 | — | *7 | |
| | | | | | | | ICLK = 32 MHz | 0.85 | — | | 0.55 | — | *7 | |
| | | | | | | | ICLK = 16 MHz | 0.70 | — | | 0.45 | — | | |
| | | ICLK = 8 MHz | 0.60 | | | | — | 0.35 | — | | | | | |
| | | All peripheral clocks enabled ^{*5} | ICLK = 48 MHz | 4.85 | | — | 2.95 | — | *9 | | | | | |
| | | | ICLK = 32 MHz | 4.68 | | — | 2.85 | — | *8 | | | | | |
| | | | ICLK = 16 MHz | 2.55 | | — | 1.55 | — | | | | | | |
| | | | ICLK = 8 MHz | 1.50 | | — | 0.95 | — | | | | | | |
| | | Increase during BGO operation ^{*6} | | | | | 2.1 | — | 1.95 | | — | | | |
| Supply current ^{*1} | Middle-speed mode ^{*2} | Normal mode | All peripheral clocks disabled, CoreMark code executing from flash ^{*5} | ICLK = 24 MHz | I _{CC} | 2.80 | — | 1.65 | — | mA | *7 | | | |
| | | | | ICLK = 4 MHz | | 0.90 | — | 0.55 | — | | | | | |
| | | | All peripheral clocks enabled, code executing from flash ^{*5} | ICLK = 24 MHz | | — | 10.0 | — | 8.8 | | | *8 | | |
| | | | | Sleep mode | | All peripheral clocks disabled ^{*5} | ICLK = 24 MHz | 0.70 | — | | | 0.45 | — | *7 |
| | | | | | | | ICLK = 4 MHz | 0.55 | — | | | 0.35 | — | |
| | | | | | | All peripheral clocks enabled ^{*5} | ICLK = 24 MHz | 3.50 | — | | | 2.10 | — | *8 |
| | | ICLK = 4 MHz | 0.95 | | | | — | 0.60 | — | | | | | |
| | | Increase during BGO operation ^{*6} | | | | | 2.00 | — | 1.65 | | — | | | |

Table 2.10 Operating and standby current (1) (2 of 2)

Conditions: VCC = AVCC0 = 1.6 to 5.5 V

| Parameter | | | | | Symbol | LDO mode | | DCDC mode ^{*12} | | Unit | Test Conditions | | |
|------------------------------|---------------------------------|-------------|--|-------------------|-----------------|--------------------|------|--------------------------|-----|------|-----------------|----|----|
| | | | | | | Typ ^{*10} | Max | Typ ^{*10} | Max | | | | |
| Supply current ^{*1} | Low-speed mode ^{*3} | Normal mode | All peripheral clocks disabled, CoreMark code executing from flash ^{*5} | ICLK = 2 MHz | I _{CC} | 0.33 | — | — | — | mA | *7 | | |
| | | | All peripheral clocks enabled, code executing from flash ^{*5} | ICLK = 2 MHz | | — | 3.1 | — | — | | *8 | | |
| | | Sleep mode | All peripheral clocks disabled ^{*5} | ICLK = 2 MHz | | 0.13 | — | — | — | | *7 | | |
| | | | All peripheral clocks enabled ^{*5} | ICLK = 2 MHz | | 0.35 | — | — | — | | *8 | | |
| | Subosc-speed mode ^{*4} | Normal mode | All peripheral clocks enabled, code executing from flash ^{*5} | ICLK = 32.768 kHz | | I _{CC} | — | 540 | — | | — | μA | *8 |
| | | | All peripheral clocks disabled ^{*5} | ICLK = 32.768 kHz | | | 2.00 | — | — | | — | | *8 |
| | | Sleep mode | All peripheral clocks disabled ^{*5} | ICLK = 32.768 kHz | | | 5.85 | — | — | | — | | *8 |
| | | | All peripheral clocks enabled ^{*5} | ICLK = 32.768 kHz | | | — | — | — | | — | | *8 |

Note 1. Supply current values do not include output charge/discharge current from all pins. The values apply when internal pull-up MOSs are in the off state.

In LDO mode, the supply current is total current flowing into VCC.

In DCDC mode, the supply current is total current flowing into VCC and VCC_DCDC.

Note 2. The clock source is HOCO.

Note 3. The clock source is MOCO.

Note 4. The clock source is the sub-clock oscillator.

Note 5. This does not include BGO and A/D operation.

Note 6. This is the increase for programming or erasure of the flash memory for data storage during program execution.

Note 7. PCLKB and PCLKD are set to divided by 64.

Note 8. PCLKB and PCLKD are the same frequency as that of ICLK.

Note 9. PCLKB are set to be divided by 2 and PCLKD is the same frequency as that of ICLK.

Note 10. VCC = 3.3 V.

Note 11. The prefetch is operating.

Note 12. VCC = AVCC0 = VCC_DCDC = 2.4 to 5.5 V

Table 2.11 Operating and standby current (2)

Conditions: VCC = AVCC0 = 1.6 to 5.5 V

| Parameter | | | | Symbol | Typ ^{*3} | Max | Unit | Test conditions | |
|------------------------------|---|--|------------------------|-----------------|-------------------|-----|--|-----------------|---|
| Supply current ^{*1} | Software Standby mode ^{*2} | All SRAMs(0x2000_4000 to 0x2000_7FFF) are on | T _a = 25°C | I _{CC} | 0.30 | 2.2 | μA | — | |
| | | | T _a = 55°C | | 0.65 | 5.3 | | | |
| | | | T _a = 85°C | | 2.0 | 20 | | | |
| | | | T _a = 105°C | | 4.0 | 70 | | | |
| | | Only 8KB SRAM (0x2000_4000 to 0x2000_5FFF) is on | T _a = 25°C | | 0.25 | 2.2 | | | |
| | | | T _a = 55°C | | 0.6 | 5.3 | | | |
| | | | T _a = 85°C | | 1.8 | 20 | | | |
| | | | T _a = 105°C | | 3.65 | 70 | | | |
| | Increment for RTC operation with low-speed on-chip oscillator ^{*4} | | | | 0.30 | — | | | — |
| | Increment for RTC operation in normal operation mode with sub-clock oscillator ^{*4} | | | | 0.20 | — | | | SOMCR.SODRV[1:0] are 11b (Low power mode 3) RCR4.ROPSEL is 0 (RTC operation in normal operation mode) |
| | | | | | 0.95 | — | | | SOMCR.SODRV[1:0] are 00b (normal mode) RCR4.ROPSEL is 0 (RTC operation in normal operation mode) |
| | Increment for RTC operation in low-consumption clock mode with sub-clock oscillator ^{*4} | | | | 0.11 | — | | | SOMCR.SODRV[1:0] are 11b (Low power mode 3) RCR4.ROPSEL is 1 (RTC operation in low-consumption clock mode) |
| 0.90 | | | | | — | | SOMCR.SODRV[1:0] are 00b (normal mode) RCR4.ROPSEL is 1 (RTC operation in low-consumption clock mode) | | |

Note 1. Supply current values do not include output charge/discharge current from all pins. The values apply when internal pull-up MOS transistors are in the off state. The supply current is total current flowing into VCC.

Note 2. The IWDT and LVD are not operating.

Note 3. VCC = 3.3 V.

Note 4. Includes the low-speed on-chip oscillator or sub-oscillation circuit current.

Table 2.12 Operating and standby current (3) (1 of 2)

Conditions: VCC = AVCC0 = 1.6 to 5.5 V

| Parameter | | Symbol | Min | Typ | Max | Unit | Test conditions |
|--|--|--------------------|-----|-----|------|------|-----------------|
| Analog power supply current | During 12-bit A/D conversion (at high-speed A/D conversion mode) | I _{AVCC0} | — | — | 1.44 | mA | — |
| | During 12-bit A/D conversion (at low-power A/D conversion mode) | | — | — | 0.78 | mA | — |
| | During 12-bit D/A conversion ^{*1} | | — | — | 0.8 | mA | — |
| | Waiting for 12-bit A/D and 12-bit D/A conversion (all units) ^{*2} | | — | — | 1.0 | μA | — |
| Reference power supply current | During 12-bit A/D conversion | I _{REFH0} | — | — | 120 | μA | — |
| | Waiting for 12-bit A/D conversion | | — | — | 60 | nA | — |
| Temperature Sensor (TSN) operating current | | I _{TNS} | — | 95 | — | μA | — |

Table 2.12 Operating and standby current (3) (2 of 2)

Conditions: VCC = AVCC0 = 1.6 to 5.5 V

| Parameter | | Symbol | Min | Typ | Max | Unit | Test conditions |
|--|-------------------------------------|--------------------|-----|-----|-----|------|-----------------|
| Low-power Analog Comparator (ACMPLP) operating current | Window comparator (high-speed mode) | I _{CMPLP} | — | 12 | — | μA | — |
| | Comparator (high-speed mode) | | — | 6.4 | — | μA | — |
| | Comparator (low-speed mode) | | — | 1.8 | — | μA | — |

Note 1. The reference power supply current is included in the power supply current value for D/A conversion.

Note 2. When the MCU is in Software Standby mode or the MSTPCRD.MSTPD16 (ADC120 module-stop bit) is in the module-stop state.

2.2.6 VCC Rise and Fall Gradient and Ripple Frequency

Table 2.13 Rise and fall gradient characteristics

Conditions: VCC = AVCC0 = 0 to 5.5 V

| Parameter | | Symbol | Min | Typ | Max | Unit | Test conditions |
|------------------------------|---|--------|------|-----|-----|------|-----------------|
| Power-on VCC rising gradient | Voltage monitor 0 reset disabled at startup | SrVCC | 0.02 | — | 2 | ms/V | — |
| | Voltage monitor 0 reset enabled at startup ^{*1 *2} | | | | — | | |
| | SCI boot mode ^{*2} | | | | 2 | | |

Note 1. When OFS1.LVDAS = 0.

Note 2. At boot mode, the reset from voltage monitor 0 is disabled regardless of the value of OFS1.LVDAS bit.

Table 2.14 Rising and falling gradient and ripple frequency characteristics

Conditions: VCC = AVCC0 = 1.6 to 5.5 V

The ripple voltage must meet the allowable ripple frequency $f_{r(VCC)}$ within the range between the VCC upper limit (5.5 V) and lower limit (1.6 V).

When the VCC change exceeds $VCC \pm 10\%$, the allowable voltage change rising and falling gradient $dt/dVCC$ must be met.

| Parameter | Symbol | Min | Typ | Max | Unit | Test conditions |
|--|--------------|-----|-----|-----|------|---|
| Allowable ripple frequency | $f_{r(VCC)}$ | — | — | 10 | kHz | Figure 2.2 $V_r(VCC) \leq VCC \times 0.2$ |
| | | — | — | 1 | MHz | Figure 2.2 $V_r(VCC) \leq VCC \times 0.08$ |
| | | — | — | 10 | MHz | Figure 2.2 $V_r(VCC) \leq VCC \times 0.06$ |
| Allowable voltage change rising and falling gradient | $dt/dVCC$ | 1.0 | — | — | ms/V | When VCC change exceeds $VCC \pm 10\%$ |

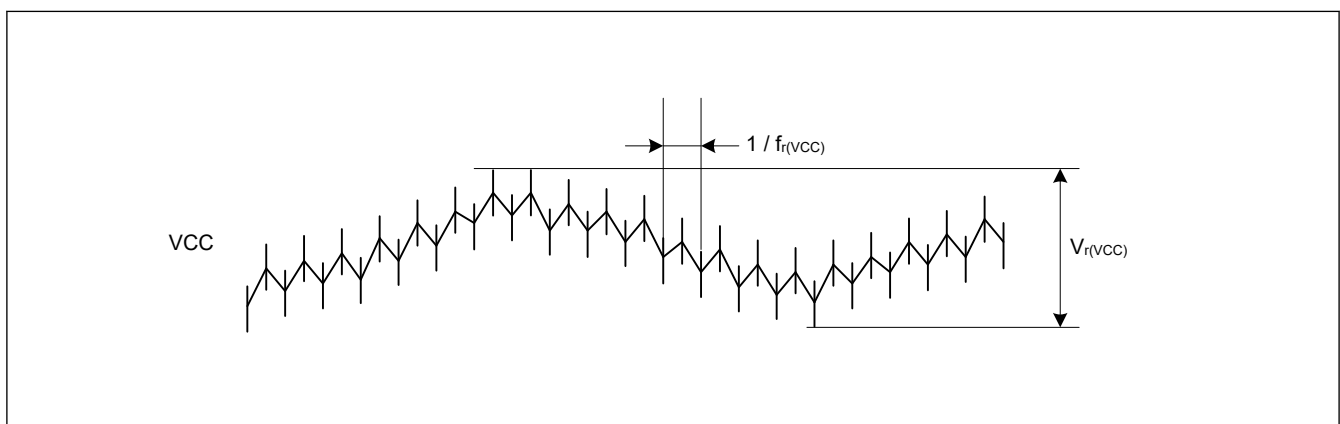

Figure 2.2 Ripple waveform

2.3 AC Characteristics

2.3.1 Frequency

Table 2.15 Operation frequency in high-speed operating mode

Conditions: VCC = AVCC0 = 1.8 to 5.5 V

| Parameter | | | Symbol | Min | Typ | Max ^{*4} | Unit |
|---------------------|---|--------------|--------|----------|-----|-------------------|------|
| Operation frequency | System clock (ICLK) ^{*1*2} | 1.8 to 5.5 V | f | 0.032768 | — | 48 | MHz |
| | Peripheral module clock (PCLKB) | 1.8 to 5.5 V | | — | — | 32 | |
| | Peripheral module clock (PCLKD) ^{*3} | 1.8 to 5.5 V | | — | — | 64 | |

Note 1. The lower-limit frequency of ICLK is 1 MHz while programming or erasing the flash memory. When using ICLK for programming or erasing the flash memory at below 4 MHz, the frequency can be set to 1 MHz, 2 MHz, or 3 MHz. A non-integer frequency such as 1.5 MHz cannot be set.

Note 2. The frequency accuracy of ICLK must be $\pm 1.0\%$ during programming or erasing the flash memory. Confirm the frequency accuracy of the clock source.

Note 3. The lower-limit frequency of PCLKD is 1 MHz when the ADC12 is in use.

Note 4. The maximum value of operation frequency does not include internal oscillator errors. For details on the range for guaranteed operation, see [Table 2.19](#).

Table 2.16 Operation frequency in middle-speed mode

Conditions: VCC = AVCC0 = 1.6 to 5.5 V

| Parameter | | | Symbol | Min | Typ | Max ^{*4} | Unit |
|---------------------|---|--------------|--------|----------|-----|-------------------|------|
| Operation frequency | System clock (ICLK) ^{*1*2} | 1.8 to 5.5 V | f | 0.032768 | — | 24 | MHz |
| | | 1.6 to 1.8 V | | 0.032768 | — | 4 | |
| | Peripheral module clock (PCLKB) | 1.8 to 5.5 V | | — | — | 24 | |
| | | 1.6 to 1.8 V | | — | — | 4 | |
| | Peripheral module clock (PCLKD) ^{*3} | 1.8 to 5.5 V | | — | — | 24 | |
| | | 1.6 to 1.8 V | | — | — | 4 | |

Note 1. The lower-limit frequency of ICLK is 1 MHz while programming or erasing the flash memory. When using ICLK for programming or erasing the flash memory at below 4 MHz, the frequency can be set to 1 MHz, 2 MHz, or 3 MHz. A non-integer frequency such as 1.5 MHz cannot be set.

Note 2. The frequency accuracy of ICLK must be $\pm 1.0\%$ while programming or erasing the flash memory. Confirm the frequency accuracy of the clock source.

Note 3. The lower-limit frequency of PCLKD is 1 MHz when the ADC12 is in use.

Note 4. The maximum value of operation frequency does not include internal oscillator errors. For details on the range for guaranteed operation, see [Table 2.19](#).

Table 2.17 Operation frequency in low-speed mode

Conditions: VCC = AVCC0 = 1.6 to 5.5 V

| Parameter | | | Symbol | Min | Typ | Max ^{*4} | Unit |
|---------------------|---|--------------|--------|----------|-----|-------------------|------|
| Operation frequency | System clock (ICLK) ^{*1*2} | 1.6 to 5.5 V | f | 0.032768 | — | 2 | MHz |
| | Peripheral module clock (PCLKB) | 1.6 to 5.5 V | | — | — | 2 | |
| | Peripheral module clock (PCLKD) ^{*3} | 1.6 to 5.5 V | | — | — | 2 | |

Note 1. The lower-limit frequency of ICLK is 1 MHz while programming or erasing the flash memory.

Note 2. The frequency accuracy of ICLK must be $\pm 1.0\%$ while programming or erasing the flash memory. Confirm the frequency accuracy of the clock source.

Note 3. The lower-limit frequency of PCLKD is 1 MHz when the ADC12 is in use.

Note 4. The maximum value of operation frequency does not include internal oscillator errors. For details on the range for guaranteed operation, see [Table 2.19](#).

Table 2.18 Operation frequency in Subosc-speed mode

Conditions: VCC = AVCC0 = 1.6 to 5.5 V

| Parameter | | | Symbol | Min | Typ | Max | Unit |
|---------------------|---|--------------|--------|---------|--------|---------|------|
| Operation frequency | System clock (ICLK) ^{*1} | 1.6 to 5.5 V | f | 27.8528 | 32.768 | 37.6832 | kHz |
| | Peripheral module clock (PCLKB) | 1.6 to 5.5 V | | — | — | 37.6832 | |
| | Peripheral module clock (PCLKD) ^{*2} | 1.6 to 5.5 V | | — | — | 37.6832 | |

Note 1. Programming and erasing the flash memory is not possible.

Note 2. The ADC12 cannot be used.

2.3.2 Clock Timing

Table 2.19 Clock timing

| Parameter | Symbol | Min | Typ | Max | Unit | Test conditions |
|--|--------------|---------|--------|---------|---------|---|
| EXTAL external clock input cycle time | t_{XCYC} | 50 | — | — | ns | Figure 2.3 |
| EXTAL external clock input high pulse width | t_{XH} | 20 | — | — | ns | |
| EXTAL external clock input low pulse width | t_{XL} | 20 | — | — | ns | |
| EXTAL external clock rising time | t_{Xr} | — | — | 5 | ns | |
| EXTAL external clock falling time | t_{Xf} | — | — | 5 | ns | |
| EXTAL external clock input wait time*1 | t_{EXWT} | 0.3 | — | — | μ s | — |
| EXTAL external clock input frequency | f_{EXTAL} | — | — | 20 | MHz | $1.8 \leq VCC \leq 5.5$ |
| | | — | — | 4 | | $1.6 \leq VCC < 1.8$ |
| Main clock oscillator oscillation frequency | f_{MAIN} | 1 | — | 20 | MHz | $1.8 \leq VCC \leq 5.5$ |
| | | 1 | — | 4 | | $1.6 \leq VCC < 1.8$ |
| LOCO clock oscillation frequency | f_{LOCO} | 27.8528 | 32.768 | 37.6832 | kHz | — |
| LOCO clock oscillation stabilization time | t_{LOCO} | — | — | 100 | μ s | Figure 2.4 |
| IWDT-dedicated clock oscillation frequency | f_{ILOCO} | 12.75 | 15 | 17.25 | kHz | — |
| MOCO clock oscillation frequency | f_{MOCO} | 6.8 | 8 | 9.2 | MHz | — |
| MOCO clock oscillation stabilization time | t_{MOCO} | — | — | 1 | μ s | — |
| HOCO clock oscillation frequency*5 | f_{HOCO24} | 23.76 | 24 | 24.24 | MHz | $T_a = -40$ to 105°C $1.6 \leq VCC \leq 5.5$ |
| | f_{HOCO32} | 31.68 | 32 | 32.32 | | $T_a = -40$ to 105°C $1.6 \leq VCC \leq 5.5$ |
| | f_{HOCO48} | 47.52 | 48 | 48.48 | | $T_a = -40$ to 105°C $1.6 \leq VCC \leq 5.5$ |
| | f_{HOCO64} | 63.36 | 64 | 64.64 | | $T_a = -40$ to 105°C $1.6 \leq VCC \leq 5.5$ |
| HOCO clock oscillation stabilization time*3 *4 | t_{HOCO24} | — | 1.9 | — | μ s | Figure 2.5 |
| | t_{HOCO32} | — | | | | |
| | t_{HOCO48} | — | | | | |
| | t_{HOCO64} | — | | | | |
| Sub-clock oscillator oscillation frequency | f_{SUB} | — | 32.768 | — | kHz | — |
| Sub-clock oscillation stabilization time*2 | t_{SUBOSC} | — | 0.5 | — | s | Figure 2.6 |

Note 1. Time until the clock can be used after the Main Clock Oscillator stop bit (MOSCCR.MOSTP) is set to 0 (operating) when the external clock is stable.

Note 2. After changing the setting of the SOSCCR.SOSTP bit to start sub-clock oscillator operation, only start using the sub-clock oscillator after the sub-clock oscillation stabilization wait time elapsed. Use the oscillator wait time value recommended by the oscillator manufacturer.

Note 3. This is a characteristic when the HOCOCCR.HCSTP bit is set to 0 (oscillation) in the MOCO stop state. When the HOCOCCR.HCSTP bit is set to 0 (oscillation) during MOCO oscillation, this specification is shortened by 1 μ s.

Note 4. Check OSCSF.HOCOSF to confirm whether stabilization time has elapsed.

Note 5. Accuracy at production test.

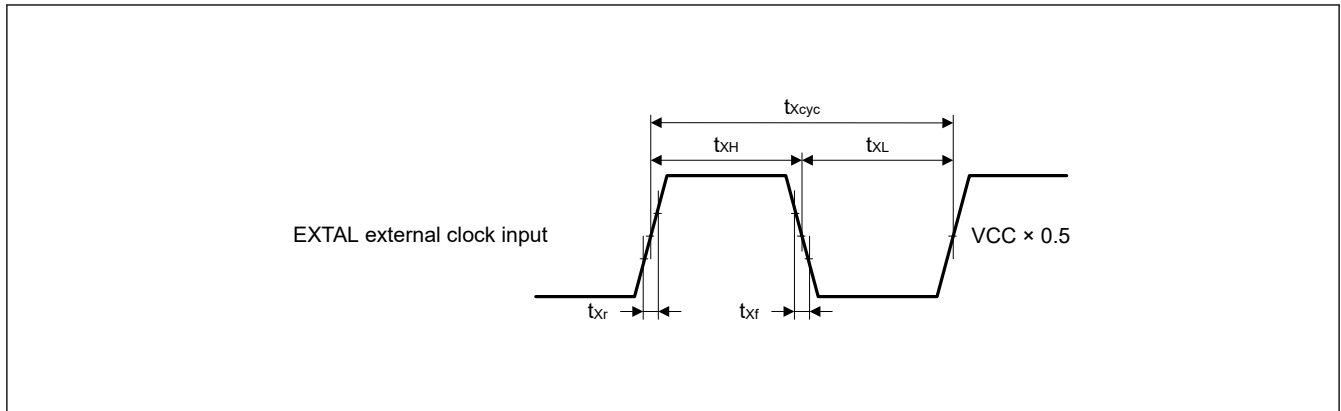

Figure 2.3 EXTAL external clock input timing

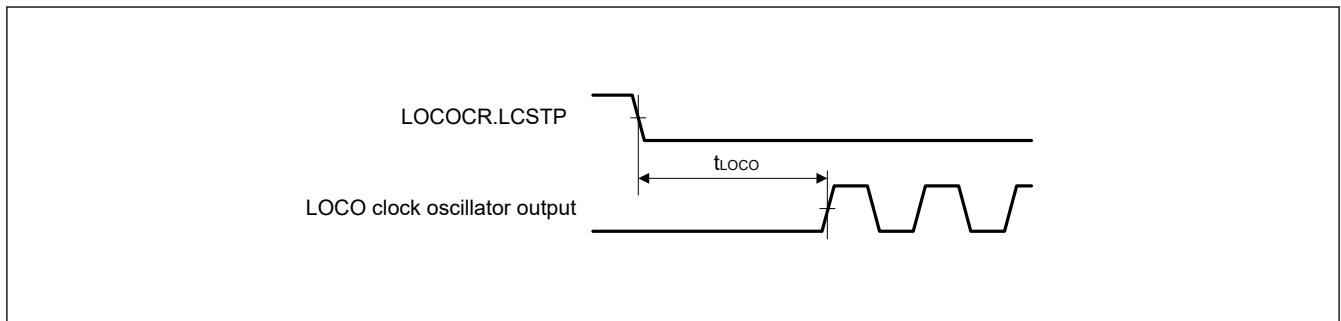

Figure 2.4 LOCO clock oscillation start timing

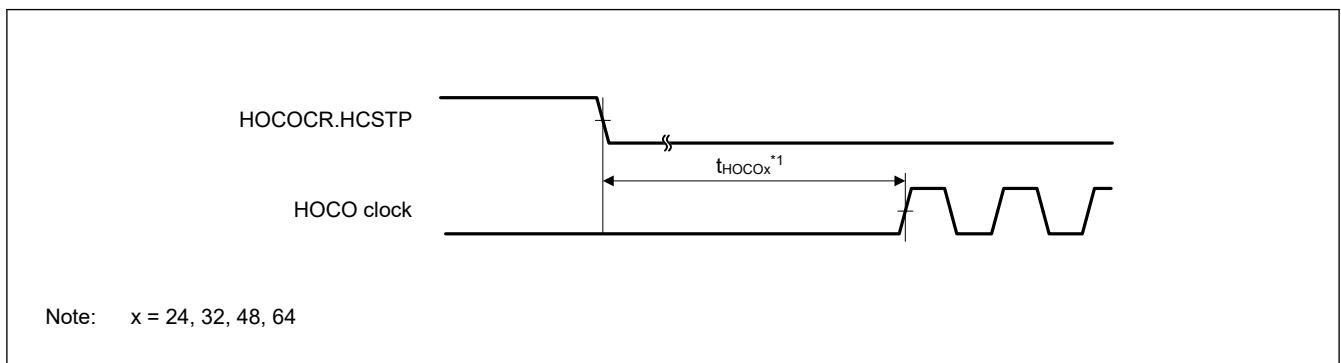

Figure 2.5 HOCO clock oscillation start timing (started by setting the HOCOCR.HCSTP bit)

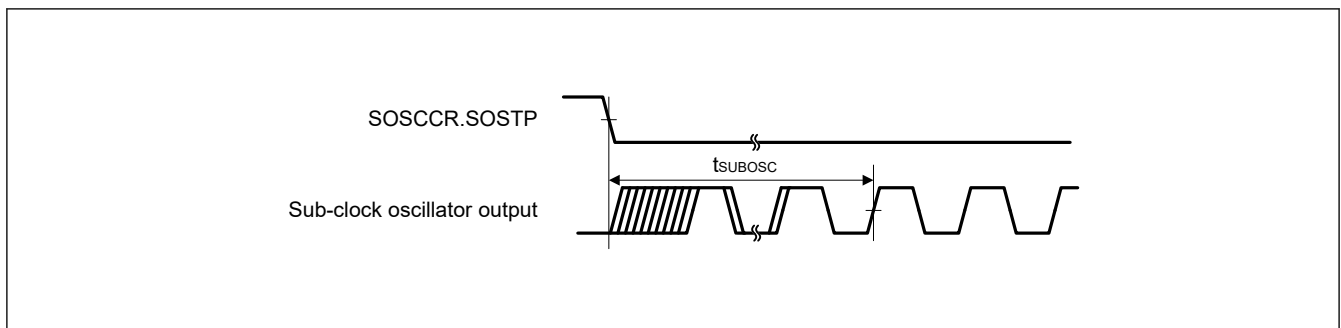

Figure 2.6 Sub-clock oscillation start timing

2.3.3 Reset Timing

Table 2.20 Reset timing

| Parameter | | Symbol | Min | Typ | Max | Unit | Test conditions |
|---|-----------------|--------------|-----|------|-----|---------|-----------------|
| RES pulse width | At power-on | t_{RESWP} | 10 | — | — | ms | Figure 2.7 |
| | Not at power-on | t_{RESW} | 30 | — | — | μ s | Figure 2.8 |
| Wait time after RES cancellation (at power-on) | LVD0 enabled*1 | t_{RESWT} | — | 0.9 | — | ms | Figure 2.7 |
| | LVD0 disabled*2 | | — | 0.2 | — | | |
| Wait time after RES cancellation (during powered-on state) | LVD0 enabled*1 | t_{RESWT2} | — | 0.9 | — | ms | Figure 2.8 |
| | LVD0 disabled*2 | | — | 0.2 | — | | |
| Wait time after internal reset cancellation (Watchdog timer reset, SRAM parity error reset, SRAM ECC error reset, bus master MPU error reset, bus slave MPU error reset, stack pointer error reset, software reset) | LVD0 enabled*1 | t_{RESWT3} | — | 0.9 | — | ms | Figure 2.9 |
| | LVD0 disabled*2 | | — | 0.15 | — | | |

Note 1. When OFS1.LVDAS = 0.

Note 2. When OFS1.LVDAS = 1.

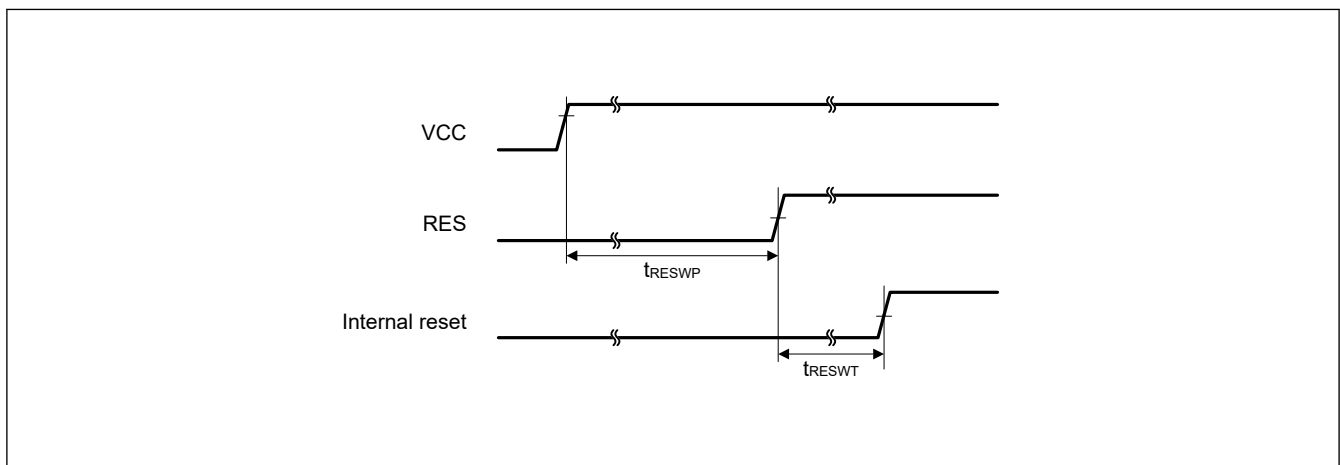

Figure 2.7 Reset input timing at power-on

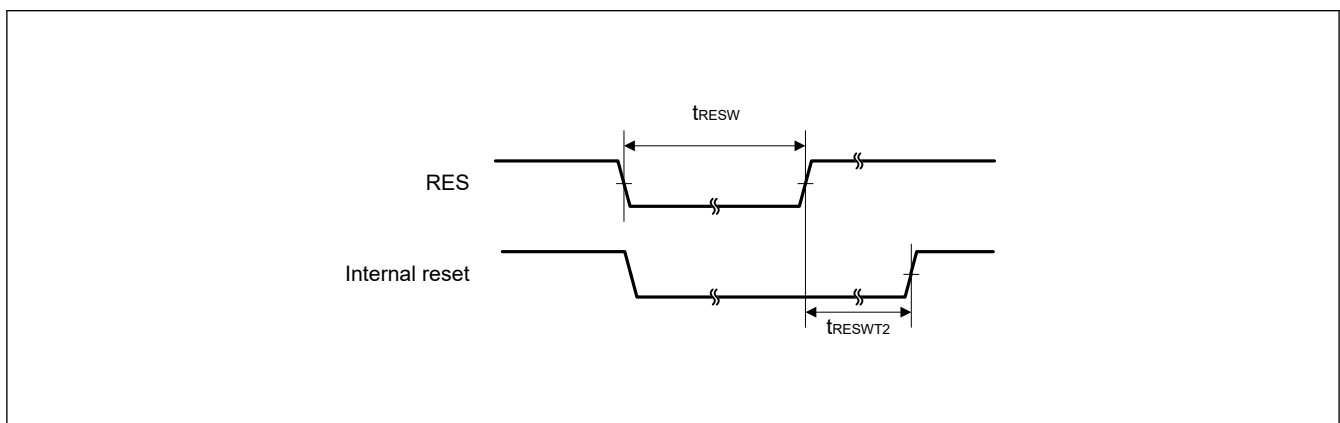

Figure 2.8 Reset input timing (1)

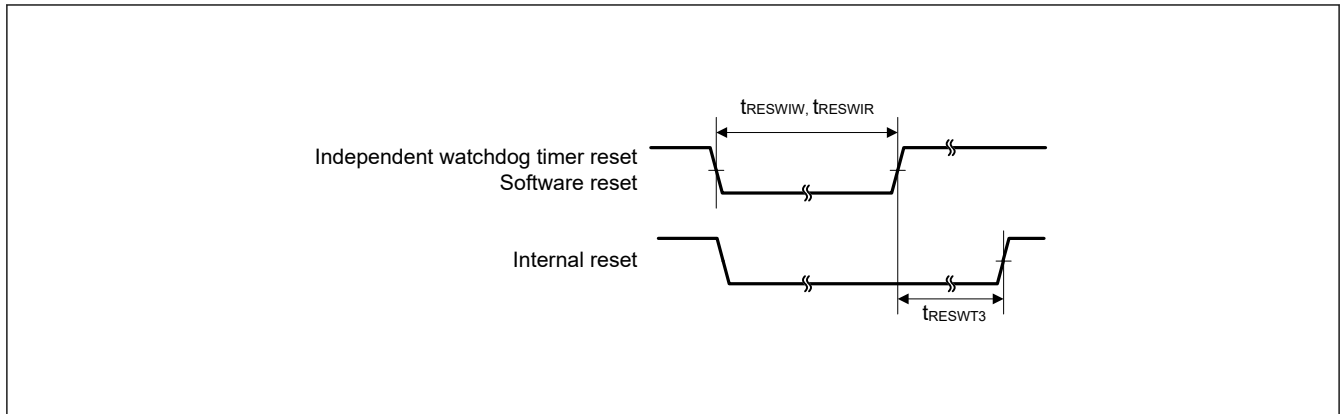

Figure 2.9 Reset input timing (2)

2.3.4 Wakeup Time

Table 2.21 Timing of recovery from low power modes (1)

| Parameter | Symbol | Min | Typ | Max | Unit | Test conditions | |
|--|--|---|--------------------|-----|------|-----------------|-------------|
| Recovery time from Software Standby mode*1 | High-speed mode | | | | | | |
| | Crystal resonator connected to main clock oscillator | System clock source is main clock oscillator (20 MHz)*2 | t _{SBYMC} | — | 2 | 3 | ms |
| | External clock input to main clock oscillator | System clock source is main clock oscillator (20 MHz)*3 | t _{SBYEX} | — | 2.4 | 3.1 | μs |
| | System clock source is HOCO (HOCO clock is 32 MHz) | t _{SBYHO} | — | 4.9 | 6.2 | μs | Figure 2.10 |
| | System clock source is HOCO (HOCO clock is 48 MHz) | t _{SBYHO} | — | 4.8 | 6 | μs | |
| | System clock source is HOCO (HOCO clock is 64 MHz) | t _{SBYHO} | — | 4.9 | 6.2 | μs | |
| System clock source is MOCO (8 MHz) | t _{SBYMO} | — | 4 | 5 | μs | | |

Note 1. The division ratio of ICLK and PCLKx is the minimum division ratio within the allowable frequency range. The recovery time is determined by the system clock source.

Note 2. The Main Clock Oscillator Wait Control Register (MOSCWTCR) is set to 0x05.

Note 3. The Main Clock Oscillator Wait Control Register (MOSCWTCR) is set to 0x00.

Table 2.22 Timing of recovery from low power modes (2)

| Parameter | | | | Symbol | Min | Typ | Max | Unit | Test conditions |
|--|-------------------|--|---|--------------------|-----|-----|-----|------|-----------------|
| Recovery time from Software Standby mode*1 | Middle-speed mode | Crystal resonator connected to main clock oscillator | System clock source is main clock oscillator (20 MHz)*2 | t _{SBYMC} | — | 2 | 3 | ms | Figure 2.10 |
| | | External clock input to main clock oscillator | System clock source is main clock oscillator (20 MHz)*3 VCC = 1.8 V to 5.5 V | t _{SBYEX} | — | 2.4 | 3.1 | μs | |
| | | | System clock source is main clock oscillator (20 MHz)*3 VCC = 1.6 V to 1.8 V | | | | | | |
| | | System clock source is HOCO*4 | VCC = 1.8 V to 5.5 V | t _{SBYHO} | — | 5.2 | 6.5 | μs | |
| | | | VCC = 1.6 V to 1.8 V | | | | | | |
| | | System clock source is MOCO (8 MHz) | VCC = 1.8 V to 5.5 V | t _{SBYMO} | — | 4 | 5 | μs | |
| VCC = 1.6 V to 1.8 V | | | | | | | | | |

Note 1. The division ratio of ICLK and PCLKx is the minimum division ratio within the allowable frequency range. The recovery time is determined by the system clock source.

Note 2. The Main Clock Oscillator Wait Control Register (MOSCWTCR) is set to 0x05.

Note 3. The Main Clock Oscillator Wait Control Register (MOSCWTCR) is set to 0x00.

Note 4. The system clock is 24 MHz.

Table 2.23 Timing of recovery from low power modes (3)

| Parameter | | | | Symbol | Min | Typ | Max | Unit | Test conditions |
|--|----------------|--|--|--------------------|-----|------|-----|------|-----------------|
| Recovery time from Software Standby mode*1 | Low-speed mode | Crystal resonator connected to main clock oscillator | System clock source is main clock oscillator (2 MHz)*2 | t _{SBYMC} | — | 2 | 3 | ms | Figure 2.10 |
| | | External clock input to main clock oscillator | System clock source is main clock oscillator (2 MHz)*3 | t _{SBYEX} | — | 14.5 | 16 | μs | |
| | | | System clock source is MOCO (2 MHz) | | | | | | |

Note 1. The division ratio of ICLK and PCLKx is the minimum division ratio within the allowable frequency range. The recovery time is determined by the system clock source.

Note 2. The Main Clock Oscillator Wait Control Register (MOSCWTCR) is set to 0x05.

Note 3. The Main Clock Oscillator Wait Control Register (MOSCWTCR) is set to 0x00.

Table 2.24 Timing of recovery from low power modes (4)

| Parameter | | | Symbol | Min | Typ | Max | Unit | Test conditions |
|--|-------------------|--|--------------------|-----|------|-----|------|-----------------|
| Recovery time from Software Standby mode*1 | Subosc-speed mode | System clock source is sub-clock oscillator (32.768 kHz) | t _{SBYSC} | — | 0.85 | 1 | ms | Figure 2.10 |
| | | System clock source is LOCO (32.768 kHz) | t _{SBYLO} | — | 0.85 | 1.2 | ms | |

Note 1. The sub-clock oscillator or LOCO itself continues oscillating in Software Standby mode during Subosc-speed mode.

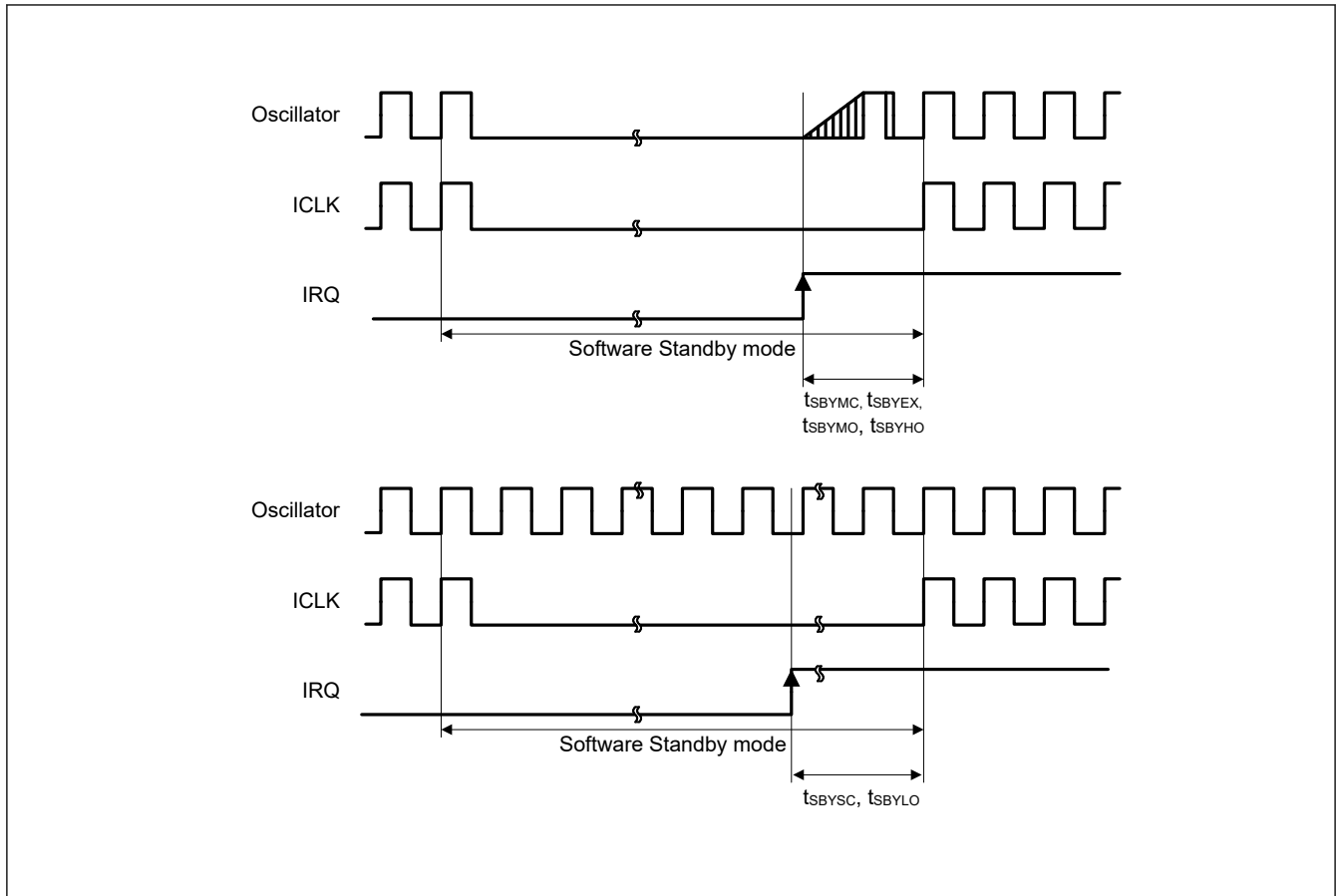

Figure 2.10 Software Standby mode cancellation timing

Table 2.25 Timing of recovery from low power modes (5)

| Parameter | | Symbol | Min | Typ | Max | Unit | Test conditions |
|---|---|-----------|-----|-----|-----|---------|-----------------|
| Recovery time from Software Standby mode to Snooze mode | High-speed mode System clock source is HOCO | t_{SNZ} | — | 4.1 | 5.2 | μs | Figure 2.11 |
| | Middle-speed mode System clock source is HOCO (24 MHz) VCC = 1.8 V to 5.5 V | t_{SNZ} | — | 4.2 | 5.3 | μs | |
| | Middle-speed mode System clock source is HOCO (24 MHz) VCC = 1.6 V to 1.8 V | t_{SNZ} | — | 8.3 | 10 | μs | |
| | Low-speed mode System clock source is MOCO (2 MHz) | t_{SNZ} | — | 6.7 | 8.0 | μs | |

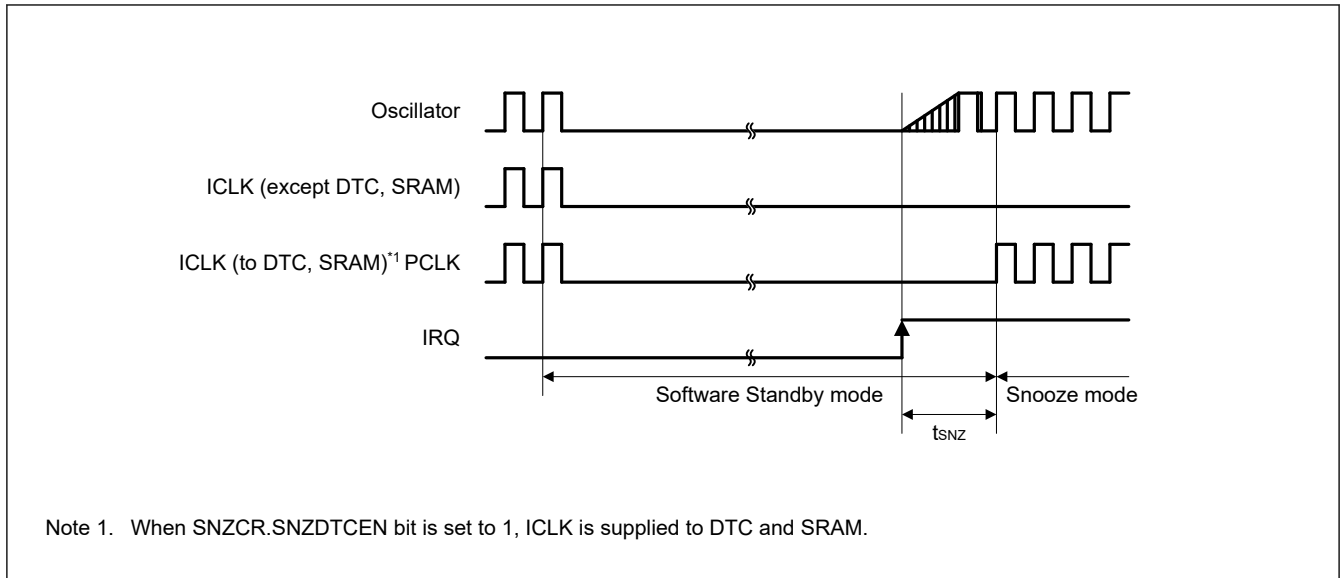

Figure 2.11 Recovery timing from Software Standby mode to Snooze mode

2.3.5 NMI and IRQ Noise Filter

Table 2.26 NMI and IRQ noise filter

| Parameter | Symbol | Min | Typ | Max | Unit | Test conditions | |
|-----------------|------------|-----------------------------|-----|-----|------|-----------------------------|----------------------------------|
| NMI pulse width | t_{NMIW} | 200 | — | — | ns | NMI digital filter disabled | $t_{Pcyc} \times 2 \leq 200$ ns |
| | | $t_{Pcyc} \times 2^{*1}$ | — | — | | | $t_{Pcyc} \times 2 > 200$ ns |
| | | 200 | — | — | | NMI digital filter enabled | $t_{NMICK} \times 3 \leq 200$ ns |
| | | $t_{NMICK} \times 3.5^{*2}$ | — | — | | | $t_{NMICK} \times 3 > 200$ ns |
| IRQ pulse width | t_{IRQW} | 200 | — | — | ns | IRQ digital filter disabled | $t_{Pcyc} \times 2 \leq 200$ ns |
| | | $t_{Pcyc} \times 2^{*1}$ | — | — | | | $t_{Pcyc} \times 2 > 200$ ns |
| | | 200 | — | — | | IRQ digital filter enabled | $t_{IRQCK} \times 3 \leq 200$ ns |
| | | $t_{IRQCK} \times 3.5^{*3}$ | — | — | | | $t_{IRQCK} \times 3 > 200$ ns |

Note: 200 ns minimum in Software Standby mode.

Note: If the clock source is being switched it is needed to add 4 clock cycle of switched source.

Note 1. t_{Pcyc} indicates the PCLKB cycle.

Note 2. t_{NMICK} indicates the cycle of the NMI digital filter sampling clock.

Note 3. t_{IRQCK} indicates the cycle of the IRQi digital filter sampling clock (i = 0 to 7).

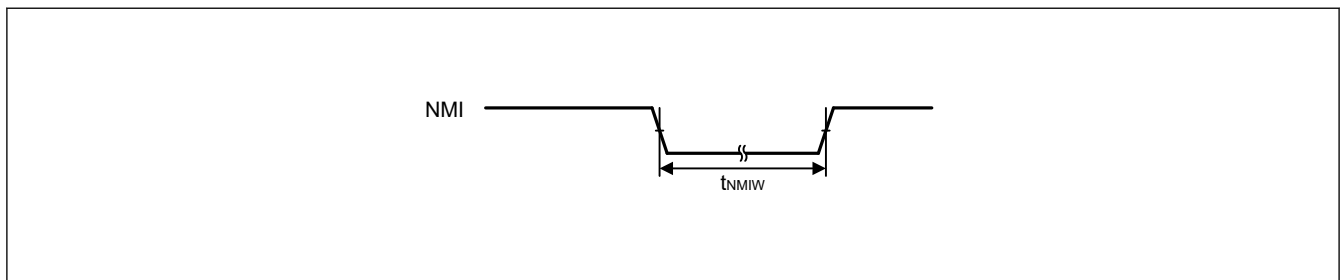

Figure 2.12 NMI interrupt input timing

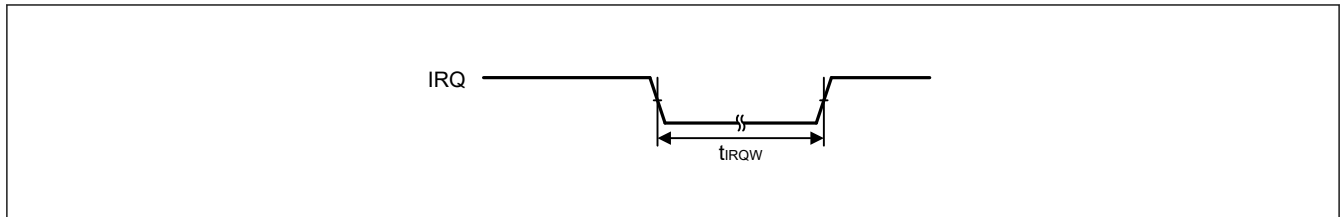

Figure 2.13 IRQ interrupt input timing

2.3.6 I/O Ports, POEG, GPT, AGT, KINT, and ADC12 Trigger Timing

Table 2.27 I/O Ports, POEG, GPT, AGT, KINT, and ADC12 trigger timing

| Parameter | | Symbol | Min | Max | Unit | Test conditions | |
|---|--|--|-----------------|------|------------|-----------------|-------------|
| I/O Ports | Input data pulse width | $2.7\text{ V} \leq \text{VCC} \leq 5.5\text{ V}$ | t_{PRW} | 2 | — | t_{Pcyc} | Figure 2.14 |
| | | $2.4\text{ V} \leq \text{VCC} < 2.7\text{ V}$ | | 3 | | | |
| | | $1.6\text{ V} \leq \text{VCC} < 2.4\text{ V}$ | | 4 | | | |
| POEG | POEG input trigger pulse width | t_{POEW} | 3 | — | t_{Pcyc} | Figure 2.15 | |
| GPT | Input capture pulse width | Single edge | t_{GTICW} | 1.5 | — | t_{PDcyc} | Figure 2.16 |
| | | Dual edge | | 2.5 | — | | |
| AGT | AGTIO, AGTEE input cycle | $1.8\text{ V} \leq \text{VCC} \leq 5.5\text{ V}$ | t_{ACYC}^{*1} | 250 | — | ns | Figure 2.17 |
| | | $1.6\text{ V} \leq \text{VCC} < 1.8\text{ V}$ | | 2000 | — | ns | |
| | AGTIO, AGTEE input high-level width, low-level width | $1.8\text{ V} \leq \text{VCC} \leq 5.5\text{ V}$ | t_{ACKWH} | 100 | — | ns | Figure 2.17 |
| | | $1.6\text{ V} \leq \text{VCC} < 1.8\text{ V}$ | t_{ACKWL} | 800 | — | ns | |
| | AGTIO, AGTO, AGTOA, AGTOB output cycle | $2.7\text{ V} \leq \text{VCC} \leq 5.5\text{ V}$ | t_{ACYC2} | 62.5 | — | ns | |
| | | $2.4\text{ V} \leq \text{VCC} < 2.7\text{ V}$ | | 125 | — | ns | |
| $1.8\text{ V} \leq \text{VCC} < 2.4\text{ V}$ | | 250 | | — | ns | | |
| $1.6\text{ V} \leq \text{VCC} < 1.8\text{ V}$ | | 500 | | — | ns | | |
| ADC12 | 12-bit A/D converter trigger input pulse width | t_{TRGW} | 1.5 | — | t_{Pcyc} | Figure 2.18 | |
| KINT | KRn (n = 00 to 07) pulse width | t_{KR} | 250 | — | ns | Figure 2.19 | |

Note 1. Constraints on AGTIO input: $t_{Pcyc} \times 2$ (t_{Pcyc} : PCLKB cycle) < t_{ACYC} .

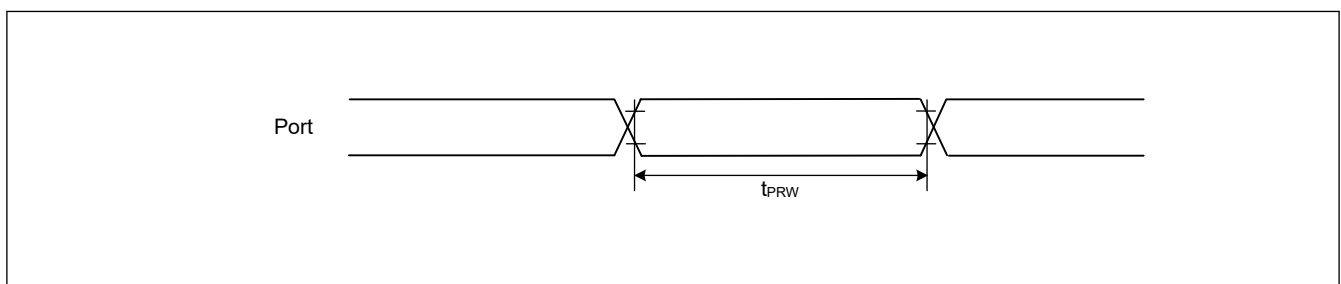

Figure 2.14 I/O ports input timing

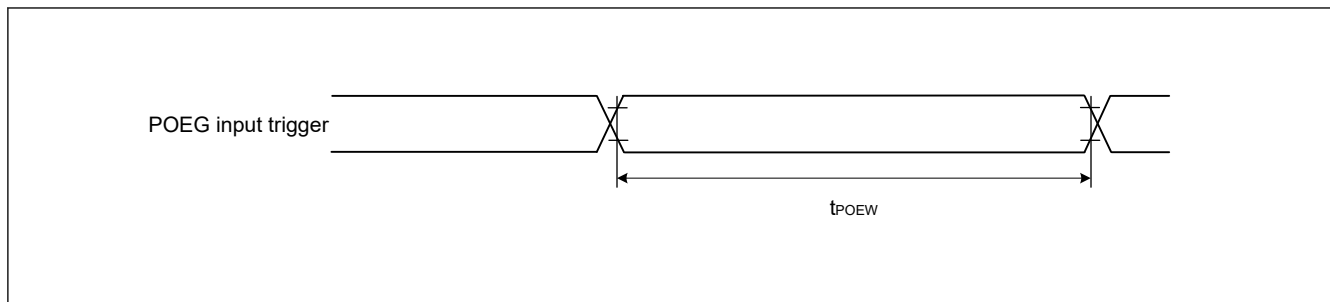

Figure 2.15 POEG input trigger timing

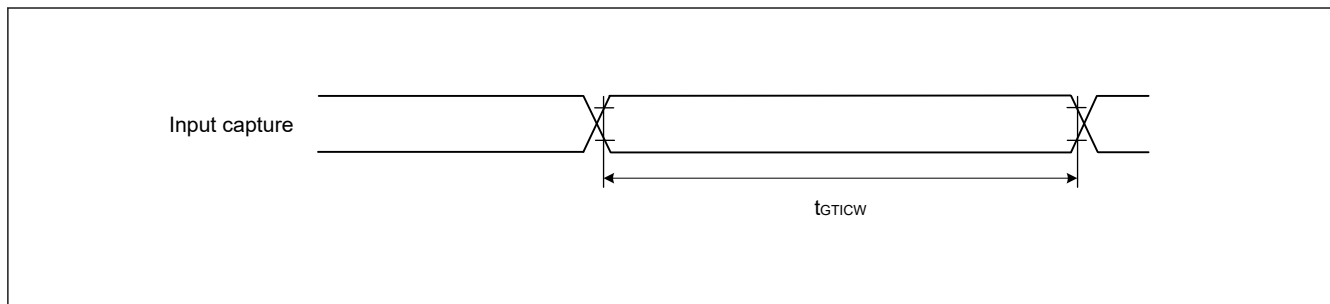

Figure 2.16 GPT input capture timing

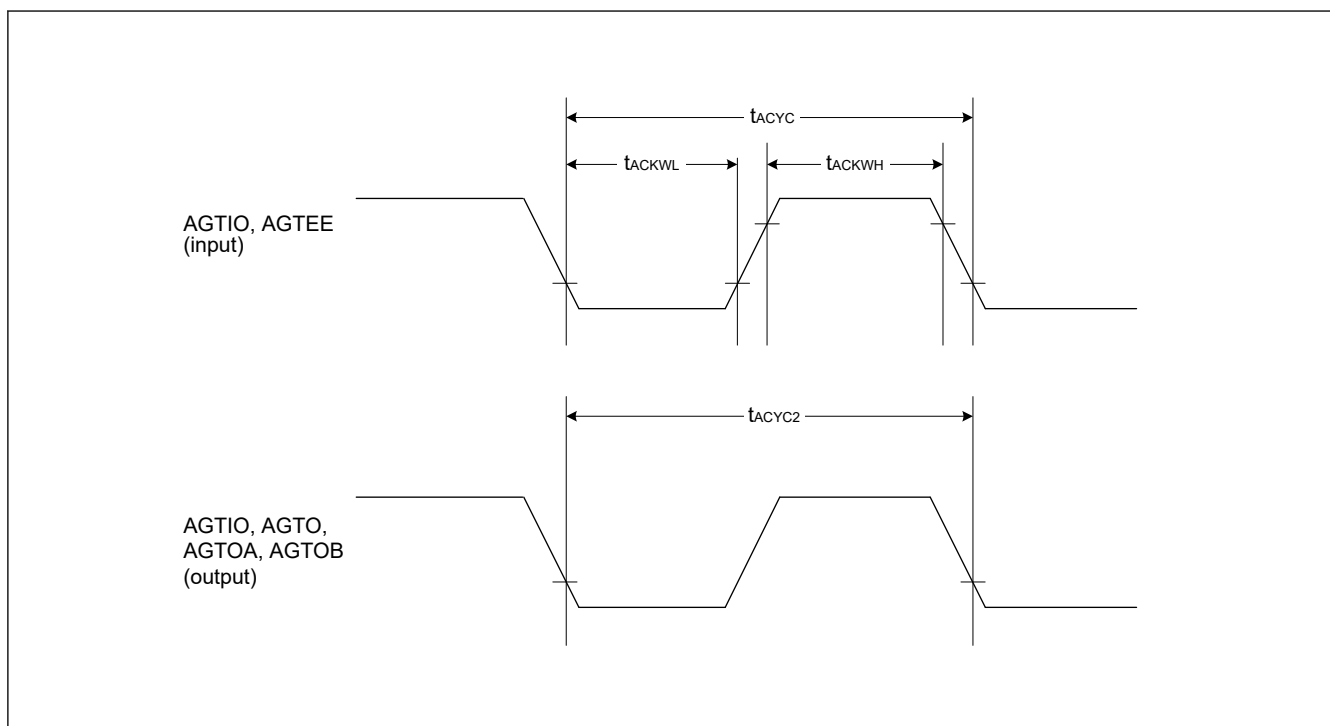

Figure 2.17 AGT I/O timing

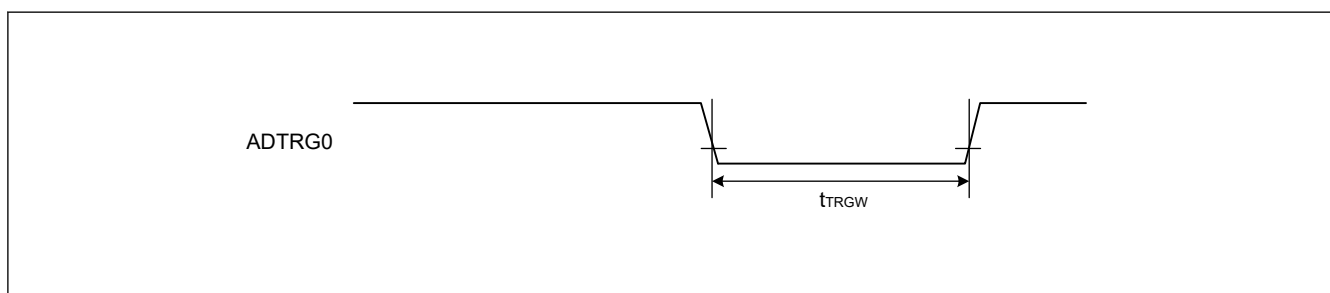

Figure 2.18 ADC12 trigger input timing

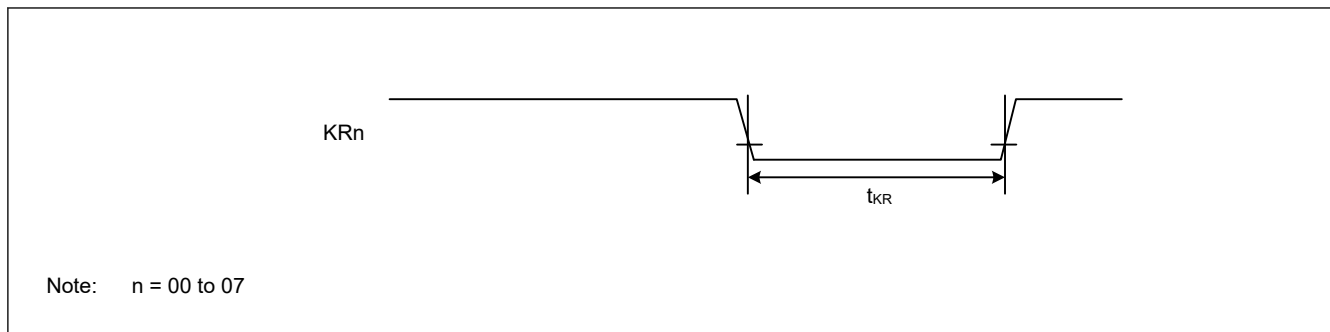

Figure 2.19 Key interrupt input timing

2.3.7 CAC Timing

Table 2.28 CAC timing

Conditions: VCC = AVCC0 = 1.6 to 5.5 V

| Parameter | | Symbol | Min | Typ | Max | Unit | Test conditions |
|-----------|--------------------------|--------------------------------------|---|---|-----|------|-----------------|
| CAC | CACREF input pulse width | $t_{P_{Cyc}}^{*1} \leq t_{CAC}^{*2}$ | t_{CACREF} | — | — | ns | — |
| | | | | $4.5 \times t_{CAC} + 3 \times t_{P_{Cyc}}$ | — | — | |
| | | $t_{P_{Cyc}}^{*1} > t_{CAC}^{*2}$ | | — | — | ns | |
| | | | $5 \times t_{CAC} + 6.5 \times t_{P_{Cyc}}$ | — | — | ns | |

Note 1. $t_{P_{Cyc}}$: PCLKB cycle.

Note 2. t_{CAC} : CAC count clock source cycle.

2.3.8 SCI Timing

Table 2.29 SCI timing (1)

Conditions: VCC = AVCC0 = 1.6 to 5.5 V

| Parameter | | | Symbol | Min | Max | Unit | Test conditions | |
|---|--|--|--|-------------------|-------|-------------------|-------------------|-------------|
| SCI | Input clock cycle | Asynchronous | $2.7\text{ V} \leq \text{VCC} \leq 5.5\text{ V}$ | t_{Scyc} | 125 | — | ns | Figure 2.20 |
| | | | $2.4\text{ V} \leq \text{VCC} < 2.7\text{ V}$ | | 250 | — | | |
| | | | $1.8\text{ V} \leq \text{VCC} < 2.4\text{ V}$ | | 500 | — | | |
| | | | $1.6\text{ V} \leq \text{VCC} < 1.8\text{ V}$ | | 1000 | — | | |
| | | Clock synchronous | $2.7\text{ V} \leq \text{VCC} \leq 5.5\text{ V}$ | | 187.5 | — | | |
| | | | $2.4\text{ V} \leq \text{VCC} < 2.7\text{ V}$ | | 375 | — | | |
| | | | $1.8\text{ V} \leq \text{VCC} < 2.4\text{ V}$ | | 750 | — | | |
| | | | $1.6\text{ V} \leq \text{VCC} < 1.8\text{ V}$ | | 1500 | — | | |
| | Input clock pulse width | | | t_{SCKW} | 0.4 | 0.6 | t_{Scyc} | |
| | Input clock rise time | | | t_{SCKr} | — | 20 | ns | |
| | Input clock fall time | | | t_{SCKf} | — | 20 | ns | |
| | Output clock cycle | Asynchronous | $2.7\text{ V} \leq \text{VCC} \leq 5.5\text{ V}$ | t_{Scyc} | 187.5 | — | ns | |
| | | | $2.4\text{ V} \leq \text{VCC} < 2.7\text{ V}$ | | 375 | — | | |
| | | | $1.8\text{ V} \leq \text{VCC} < 2.4\text{ V}$ | | 750 | — | | |
| | | | $1.6\text{ V} \leq \text{VCC} < 1.8\text{ V}$ | | 1500 | — | | |
| | | Clock synchronous | $2.7\text{ V} \leq \text{VCC} \leq 5.5\text{ V}$ | | 125 | — | | |
| $2.4\text{ V} \leq \text{VCC} < 2.7\text{ V}$ | | | 250 | | — | | | |
| $1.8\text{ V} \leq \text{VCC} < 2.4\text{ V}$ | | | 500 | | — | | | |
| $1.6\text{ V} \leq \text{VCC} < 1.8\text{ V}$ | | | 1000 | | — | | | |
| Output clock pulse width | | | t_{SCKW} | 0.4 | 0.6 | t_{Scyc} | | |
| Output clock rise time | $1.8\text{ V} \leq \text{VCC} \leq 5.5\text{ V}$ | | t_{SCKr} | — | 20 | ns | | |
| | $1.6\text{ V} \leq \text{VCC} < 1.8\text{ V}$ | | | — | 30 | | | |
| Output clock fall time | $1.8\text{ V} \leq \text{VCC} \leq 5.5\text{ V}$ | | t_{SCKf} | — | 20 | ns | | |
| | $1.6\text{ V} \leq \text{VCC} < 1.8\text{ V}$ | | | — | 30 | | | |
| Transmit data delay time (master) | Clock synchronous | $1.8\text{ V} \leq \text{VCC} \leq 5.5\text{ V}$ | t_{TXD} | — | 40 | ns | | |
| | | $1.6\text{ V} \leq \text{VCC} < 1.8\text{ V}$ | | — | 45 | | | |
| Transmit data delay time (slave) | Clock synchronous | $2.7\text{ V} \leq \text{VCC} \leq 5.5\text{ V}$ | t_{TXD} | — | 55 | ns | | |
| | | $2.4\text{ V} \leq \text{VCC} < 2.7\text{ V}$ | | — | 60 | | | |
| | | $1.8\text{ V} \leq \text{VCC} < 2.4\text{ V}$ | | — | 100 | | | |
| | | $1.6\text{ V} \leq \text{VCC} < 1.8\text{ V}$ | | — | 125 | | | |
| Receive data setup time (master) | Clock synchronous | $2.7\text{ V} \leq \text{VCC} \leq 5.5\text{ V}$ | t_{RXS} | 45 | — | ns | | |
| | | $2.4\text{ V} \leq \text{VCC} < 2.7\text{ V}$ | | 55 | — | | | |
| | | $1.8\text{ V} \leq \text{VCC} < 2.4\text{ V}$ | | 90 | — | | | |
| | | $1.6\text{ V} \leq \text{VCC} < 1.8\text{ V}$ | | 110 | — | | | |
| Receive data setup time (slave) | Clock synchronous | $2.7\text{ V} \leq \text{VCC} \leq 5.5\text{ V}$ | t_{RXS} | 40 | — | ns | | |
| | | $1.6\text{ V} \leq \text{VCC} < 2.7\text{ V}$ | | 45 | — | | | |
| Receive data hold time (master) | Clock synchronous | | t_{RXH} | 5 | — | ns | | |
| Receive data hold time (slave) | Clock synchronous | | t_{RXH} | 40 | — | ns | | |

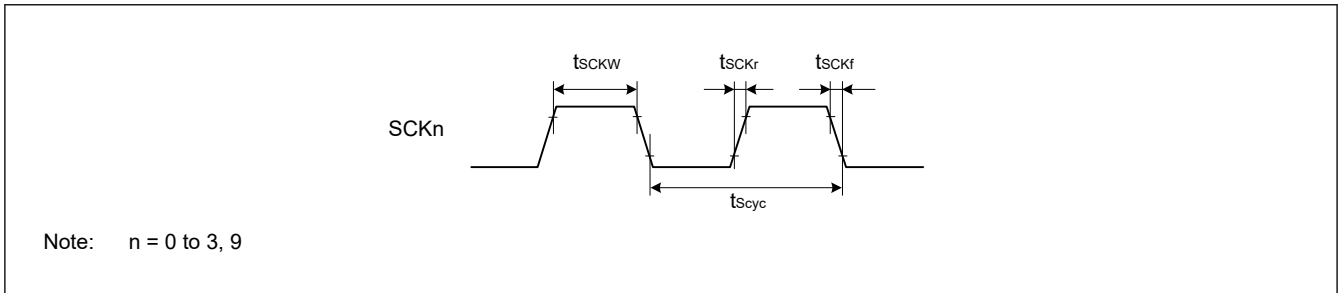

Figure 2.20 SCK clock input timing

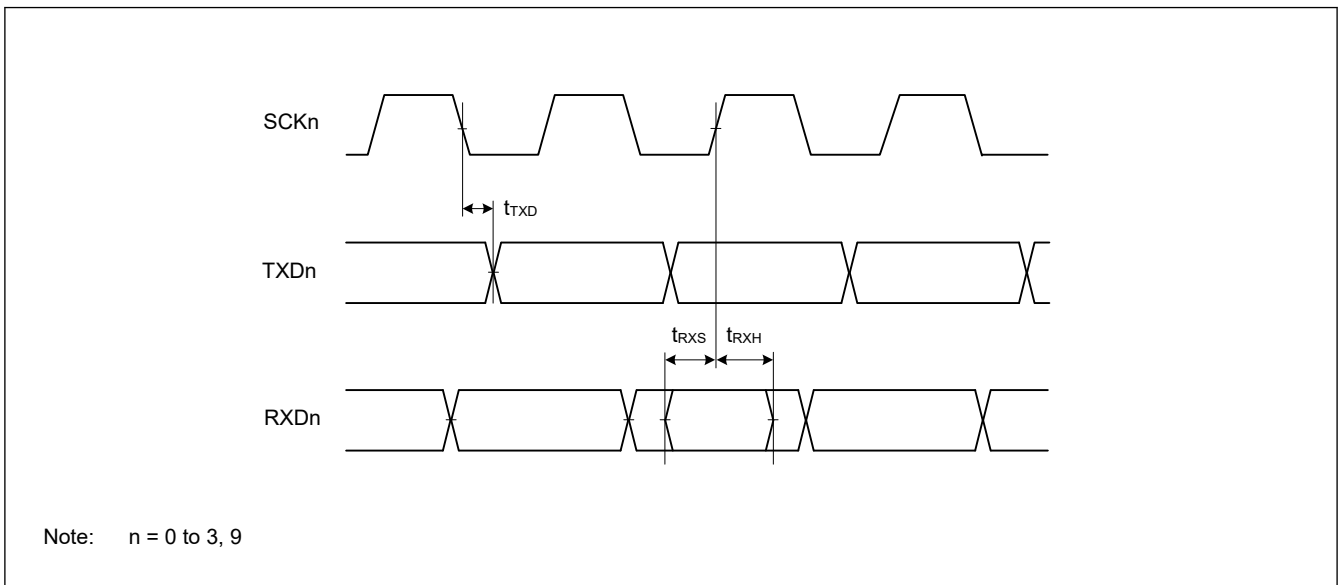

Figure 2.21 SCI input/output timing in clock synchronous mode

Table 2.30 SCI timing (2) (1 of 2)

Conditions: VCC = AVCC0 = 1.6 to 5.5 V

| Parameter | | | Symbol | Min | Max | Unit*1 | Test conditions | | | | |
|---|--|--|--------------------|--|--------------------------------|--------------------|----------------------------|-----|-----|--------------------|--|
| Simple SPI | SCK clock cycle output (master) | $2.7\text{ V} \leq \text{VCC} \leq 5.5\text{ V}$ | t_{SPcyc} | 125 | — | ns | Figure 2.22 | | | | |
| | | $2.4\text{ V} \leq \text{VCC} < 2.7\text{ V}$ | | 250 | — | | | | | | |
| | | $1.8\text{ V} \leq \text{VCC} < 2.4\text{ V}$ | | 500 | — | | | | | | |
| | | $1.6\text{ V} \leq \text{VCC} < 1.8\text{ V}$ | | 1000 | — | | | | | | |
| | SCK clock cycle input (slave) | $2.7\text{ V} \leq \text{VCC} \leq 5.5\text{ V}$ | | 187.5 | — | | | | | | |
| | | $2.4\text{ V} \leq \text{VCC} < 2.7\text{ V}$ | | 375 | — | | | | | | |
| | | $1.8\text{ V} \leq \text{VCC} < 2.4\text{ V}$ | | 750 | — | | | | | | |
| | | $1.6\text{ V} \leq \text{VCC} < 1.8\text{ V}$ | | 1500 | — | | | | | | |
| | SCK clock high pulse width | | | | t_{SPCKWH} | | | 0.4 | 0.6 | t_{SPcyc} | |
| | SCK clock low pulse width | | | | t_{SPCKWL} | | | 0.4 | 0.6 | t_{SPcyc} | |
| SCK clock rise and fall time | $1.8\text{ V} \leq \text{VCC} \leq 5.5\text{ V}$ | | t_{SPCKr} | — | 20 | ns | | | | | |
| | $1.6\text{ V} \leq \text{VCC} < 1.8\text{ V}$ | | t_{SPCKf} | — | 30 | | | | | | |
| Data input setup time | Master | $2.7\text{ V} \leq \text{VCC} \leq 5.5\text{ V}$ | t_{SU} | 45 | — | ns | Figure 2.23 to Figure 2.26 | | | | |
| | | $2.4\text{ V} \leq \text{VCC} < 2.7\text{ V}$ | | 55 | — | | | | | | |
| | | $1.8\text{ V} \leq \text{VCC} < 2.4\text{ V}$ | | 80 | — | | | | | | |
| | | $1.6\text{ V} \leq \text{VCC} < 1.8\text{ V}$ | | 110 | — | | | | | | |
| | Slave | $2.7\text{ V} \leq \text{VCC} \leq 5.5\text{ V}$ | | 40 | — | | | | | | |
| | | $1.6\text{ V} \leq \text{VCC} < 2.7\text{ V}$ | | 45 | — | | | | | | |
| Data input hold time | Master | | t_{H} | 33.3 | — | ns | | | | | |
| | Slave | | | 40 | — | | | | | | |
| SS input setup time | | | t_{LEAD} | 1 | — | t_{SPcyc} | | | | | |
| SS input hold time | | | t_{LAG} | 1 | — | t_{SPcyc} | | | | | |
| Data output delay time | Master | $1.8\text{ V} \leq \text{VCC} \leq 5.5\text{ V}$ | t_{OD} | — | 40 | ns | | | | | |
| | | $1.6\text{ V} \leq \text{VCC} < 1.8\text{ V}$ | | — | 50 | | | | | | |
| | Slave | $2.4\text{ V} \leq \text{VCC} \leq 5.5\text{ V}$ | | — | 65 | | | | | | |
| | | $1.8\text{ V} \leq \text{VCC} < 2.4\text{ V}$ | | — | 100 | | | | | | |
| | | $1.6\text{ V} \leq \text{VCC} < 1.8\text{ V}$ | | — | 125 | | | | | | |
| Data output hold time | Master | $2.7\text{ V} \leq \text{VCC} \leq 5.5\text{ V}$ | t_{OH} | -10 | — | ns | | | | | |
| | | $2.4\text{ V} \leq \text{VCC} < 2.7\text{ V}$ | | -20 | — | | | | | | |
| | | $1.8\text{ V} \leq \text{VCC} < 2.4\text{ V}$ | | -30 | — | | | | | | |
| | | $1.6\text{ V} \leq \text{VCC} < 1.8\text{ V}$ | | -40 | — | | | | | | |
| | Slave | | | | -10 | | | — | | | |
| | Data rise and fall time | Master | | $1.8\text{ V} \leq \text{VCC} \leq 5.5\text{ V}$ | $t_{\text{Dr}}, t_{\text{Df}}$ | | | — | 20 | ns | |
| $1.6\text{ V} \leq \text{VCC} < 1.8\text{ V}$ | | | — | 30 | | | | | | | |
| Slave | | $1.8\text{ V} \leq \text{VCC} \leq 5.5\text{ V}$ | — | 20 | | | | | | | |
| | | $1.6\text{ V} \leq \text{VCC} < 1.8\text{ V}$ | — | 30 | | | | | | | |

Table 2.30 SCI timing (2) (2 of 2)

Conditions: VCC = AVCC0 = 1.6 to 5.5 V

| Parameter | | Symbol | Min | Max | Unit*1 | Test conditions | |
|------------|---------------------------|---------------------|-------------------------|-----|-------------------|-----------------|-------------------|
| Simple SPI | Slave access time | 2.4 V ≤ VCC ≤ 5.5 V | — | 6 | t _{Pcyc} | Figure 2.26 | |
| | | 1.8 V ≤ VCC < 2.4 V | 24 MHz ≤ PCLKB ≤ 32 MHz | — | | | 7 |
| | | | PCLKB < 24 MHz | — | | | 6 |
| | | 1.6 V ≤ VCC < 1.8 V | — | 6 | | | |
| | Slave output release time | 2.4 V ≤ VCC ≤ 5.5 V | t _{REL} | — | 6 | | t _{Pcyc} |
| | | 1.8 V ≤ VCC < 2.4 V | 24 MHz ≤ PCLKB ≤ 32 MHz | — | 7 | | |
| | | | PCLKB < 24 MHz | — | 6 | | |
| | | 1.6 V ≤ VCC < 1.8 V | — | 6 | | | |

Note 1. t_{Pcyc}: PCLKB cycle.

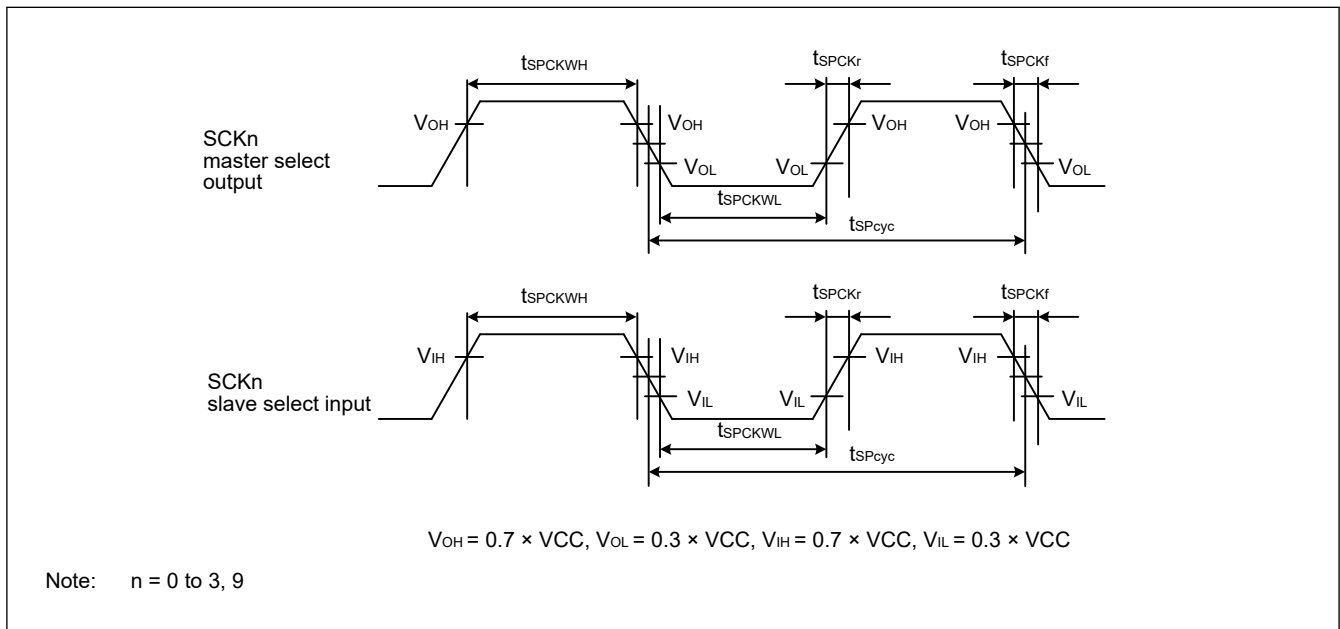

Figure 2.22 SCI simple SPI mode clock timing

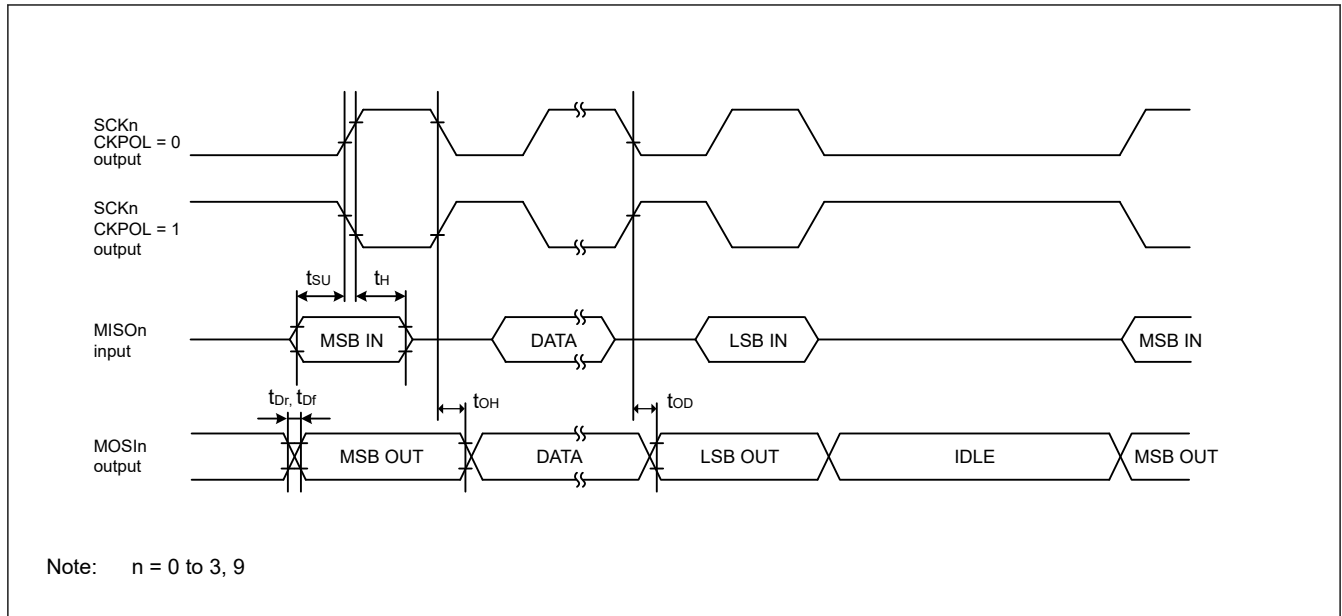

Figure 2.23 SCI simple SPI mode timing (master, CKPH = 1)

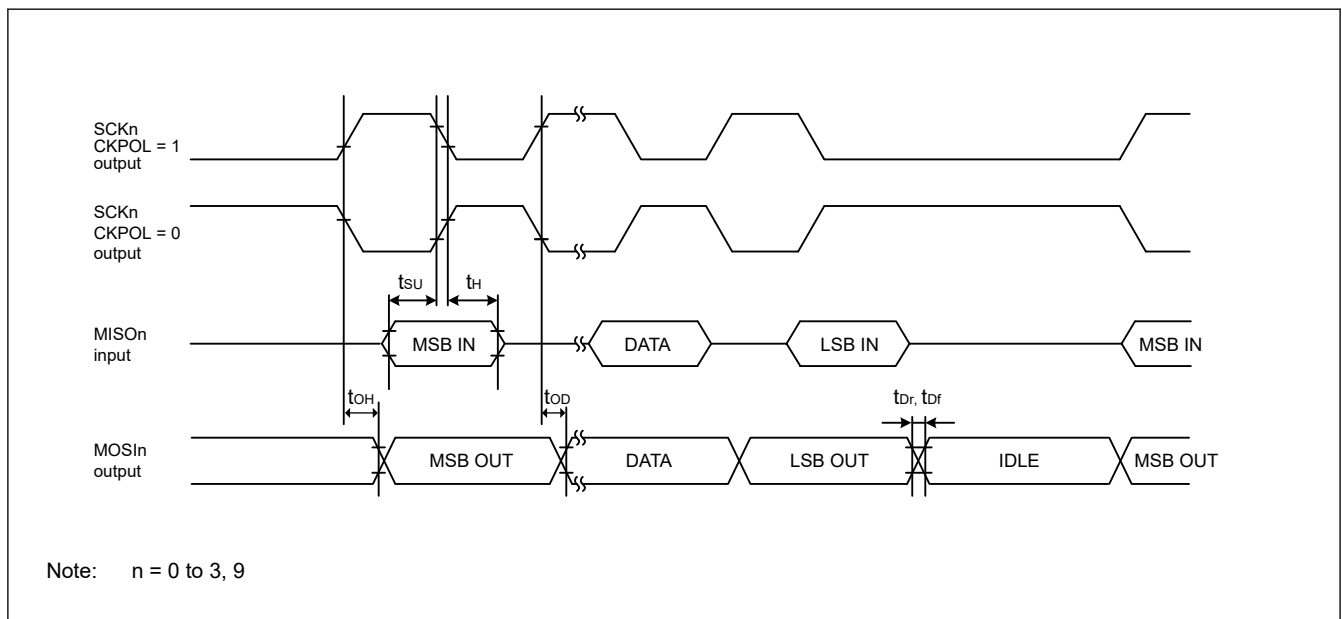

Figure 2.24 SCI simple SPI mode timing (master, CKPH = 0)

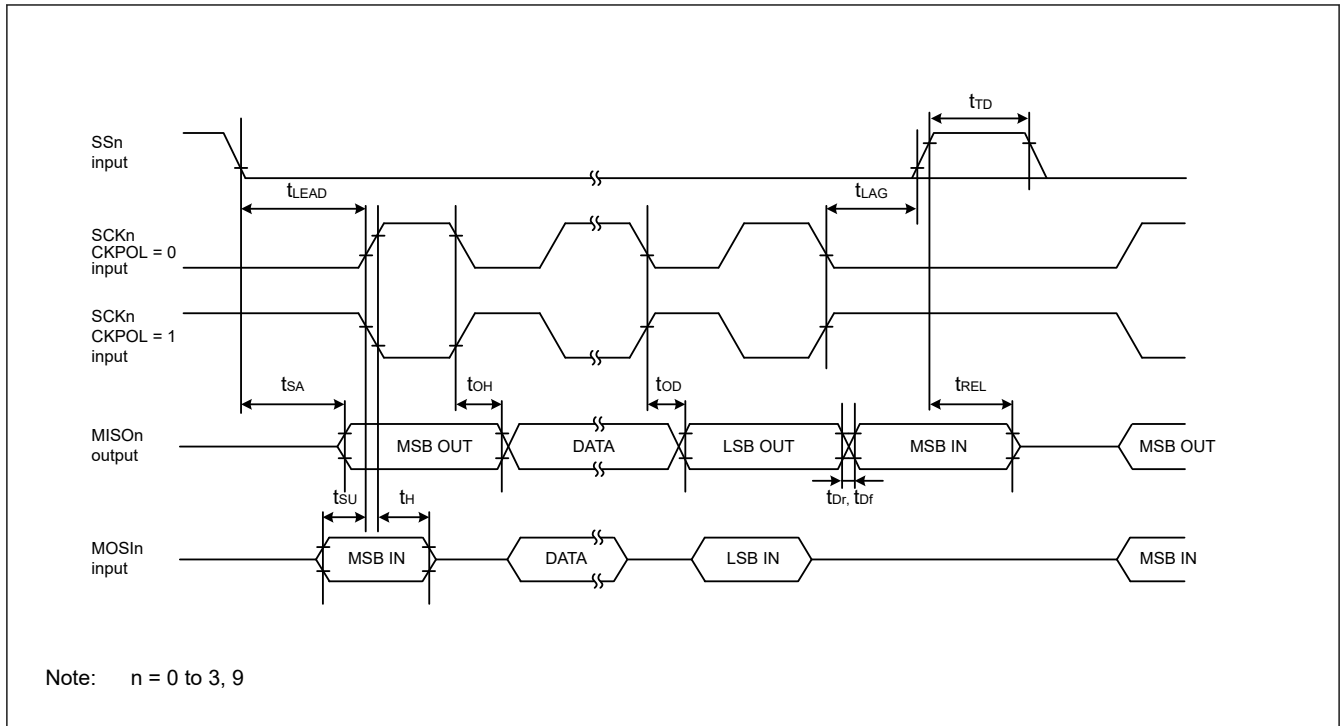

Figure 2.25 SCI simple SPI mode timing (slave, CKPH = 1)

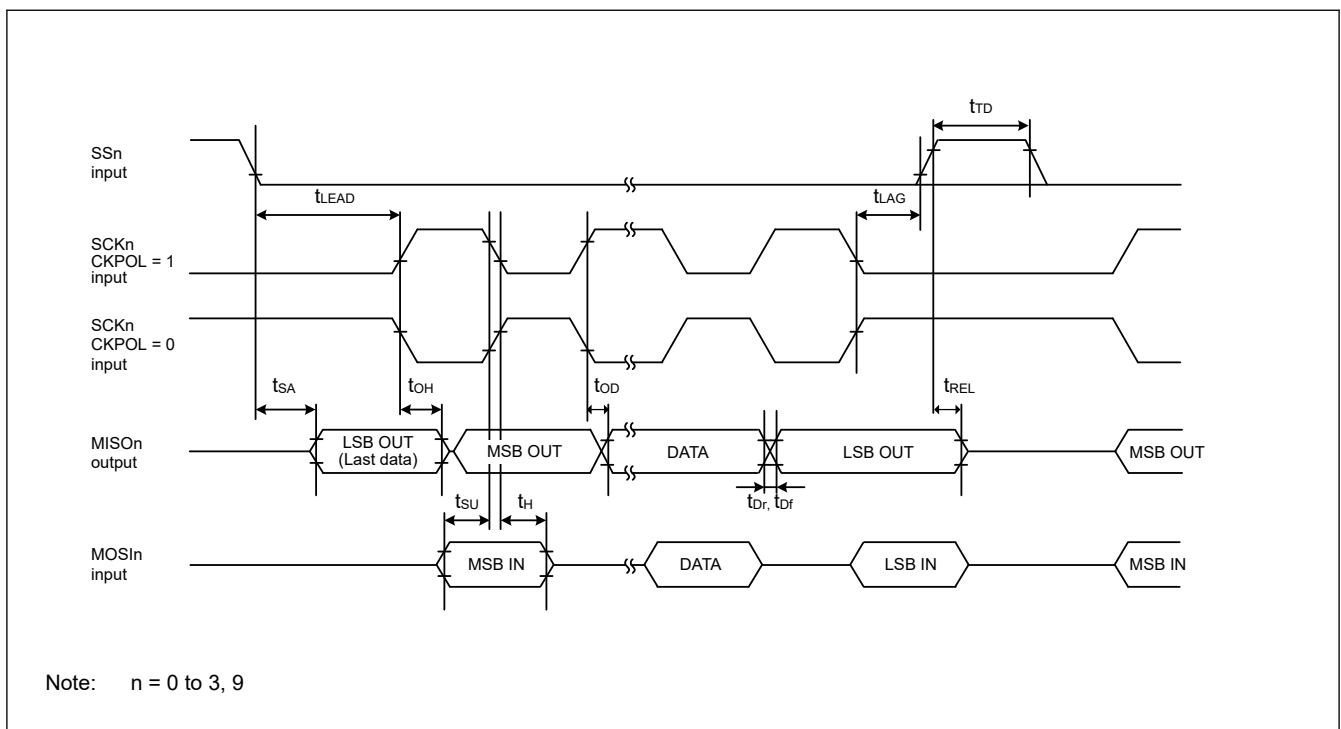

Figure 2.26 SCI simple SPI mode timing (slave, CKPH = 0)

Table 2.31 SCI timing (3)

Conditions: VCC = AVCC0 = 2.7 to 5.5 V

| Parameter | Symbol | Min | Max | Unit | Test conditions | |
|----------------------------|------------------------------------|------------|-----|----------------------------|-----------------|-------------|
| Simple IIC (Standard mode) | SDA input rise time | t_{Sr} | — | 1000 | ns | Figure 2.27 |
| | SDA input fall time | t_{Sf} | — | 300 | ns | |
| | SDA input spike pulse removal time | t_{SP} | 0 | $4 \times t_{IICcyc}^{*1}$ | ns | |
| | Data input setup time | t_{SDAS} | 250 | — | ns | |
| | Data input hold time | t_{SDAH} | 0 | — | ns | |
| | SCL, SDA capacitive load | C_b^{*2} | — | 400 | pF | |
| Simple IIC (Fast mode) | SDA input rise time | t_{Sr} | — | 300 | ns | Figure 2.27 |
| | SDA input fall time | t_{Sf} | — | 300 | ns | |
| | SDA input spike pulse removal time | t_{SP} | 0 | $4 \times t_{IICcyc}^{*1}$ | ns | |
| | Data input setup time | t_{SDAS} | 100 | — | ns | |
| | Data input hold time | t_{SDAH} | 0 | — | ns | |
| | SCL, SDA capacitive load | C_b^{*2} | — | 400 | pF | |

Note 1. t_{IICcyc} : Clock cycle selected by the SMR.CKS[1:0] bits.

Note 2. C_b indicates the total capacity of the bus line.

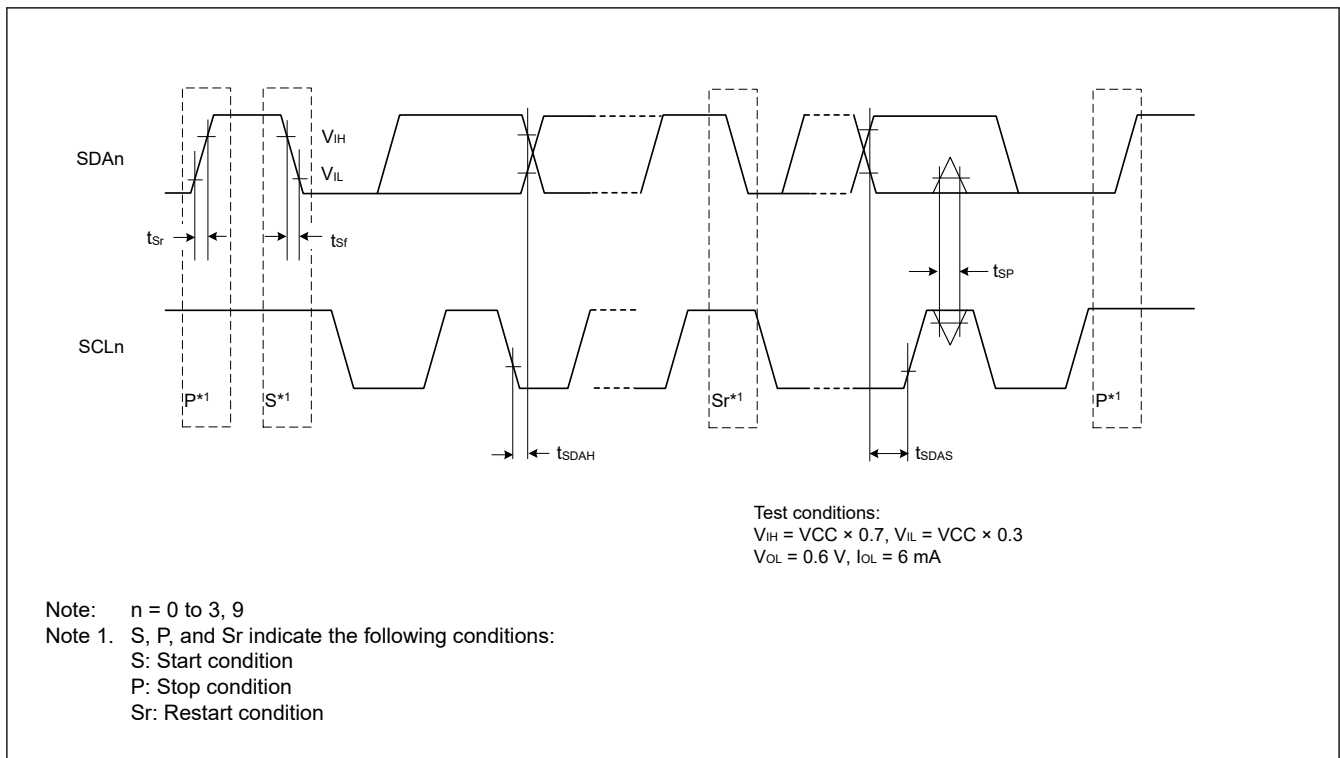

Figure 2.27 SCI simple IIC mode timing

2.3.9 SPI Timing

Table 2.32 SPI timing (1 of 3)

| Parameter | | | Symbol | Min | Max | Unit ^{*1} | Test conditions | |
|--------------------------------|------------------------------|--|--|---------------------|--|--------------------|-----------------|--------------------------|
| SPI | RSPCK clock cycle | Master | $2.7\text{ V} \leq \text{VCC} \leq 5.5\text{ V}$ | t_{SPcyc} | 62.5 | — | ns | Figure 2.28 C = 30 pF |
| | | | $2.4\text{ V} \leq \text{VCC} < 2.7\text{ V}$ | 125 | — | | | |
| | | | $1.8\text{ V} \leq \text{VCC} < 2.4\text{ V}$ | 250 | — | | | |
| | | | $1.6\text{ V} \leq \text{VCC} < 1.8\text{ V}$ | 500 | — | | | |
| | | Slave | $2.7\text{ V} \leq \text{VCC} \leq 5.5\text{ V}$ | 187.5 | — | | | |
| | | | $2.4\text{ V} \leq \text{VCC} < 2.7\text{ V}$ | 375 | — | | | |
| | | | $1.8\text{ V} \leq \text{VCC} < 2.4\text{ V}$ | 750 | — | | | |
| | | | $1.6\text{ V} \leq \text{VCC} < 1.8\text{ V}$ | 1500 | — | | | |
| | RSPCK clock high pulse width | Master | | t_{SPCKWH} | $(t_{\text{SPcyc}} - t_{\text{SPCKr}} - t_{\text{SPCKf}}) / 2 - 3$ | — | ns | |
| | | Slave | | | $3 \times t_{\text{Pcyc}}$ | — | | |
| | RSPCK clock low pulse width | Master | | t_{SPCKWL} | $(t_{\text{SPcyc}} - t_{\text{SPCKr}} - t_{\text{SPCKf}}) / 2 - 3$ | — | ns | |
| | | Slave | | | $3 \times t_{\text{Pcyc}}$ | — | | |
| RSPCK clock rise and fall time | Output | $2.7\text{ V} \leq \text{VCC} \leq 5.5\text{ V}$ | t_{SPCKr} | — | 10 | ns | | |
| | | $2.4\text{ V} \leq \text{VCC} < 2.7\text{ V}$ | t_{SPCKf} | — | 15 | | | |
| | | $1.8\text{ V} \leq \text{VCC} \leq 2.4\text{ V}$ | — | 20 | | | | |
| | | $1.6\text{ V} \leq \text{VCC} < 1.8\text{ V}$ | — | 30 | | | | |
| | Input | | | — | 0.1 | $\mu\text{s/V}$ | | |

Table 2.32 SPI timing (2 of 3)

| Parameter | | | | Symbol | Min | Max | Unit*1 | Test conditions | |
|------------------------------------|-------------------------------|-----------------------|---------------------|--|--|--|--------|-----------------|---|
| SPI | Data input setup time | Master | 2.7 V ≤ VCC ≤ 5.5 V | | t _{SU} | 10 | — | ns | Figure 2.29 to Figure 2.34 C = 30 pF |
| | | | 2.4 V ≤ VCC < 2.7 V | 16 MHz < PCLKB ≤ 32 MHz | | 30 | — | | |
| | | | | PCLKB ≤ 16 MHz | | 10 | — | | |
| | | | 1.8 V ≤ VCC < 2.4 V | 16 MHz < PCLKB ≤ 32 MHz | | 55 | — | | |
| | | | | 8 MHz < PCLKB ≤ 16 MHz | | 30 | — | | |
| | | | | PCLKB ≤ 8 MHz | | 10 | — | | |
| | | 1.6 V ≤ VCC < 1.8 V | | 10 | — | | | | |
| | | Slave | 2.4 V ≤ VCC ≤ 5.5 V | | 10 | — | | | |
| | | | 1.8 V ≤ VCC < 2.4 V | | 15 | — | | | |
| | | | 1.6 V ≤ VCC < 1.8 V | | 20 | — | | | |
| Data input hold time | Master (RSPCK is PCLKB/2) | | t _{HF} | 0 | — | ns | | | |
| | Master (RSPCK is not PCLKB/2) | | t _H | t _{Pcyc} | — | | | | |
| | Slave | | t _H | 20 | — | | | | |
| SPI | SSL setup time | Master | 1.8 V ≤ VCC ≤ 5.5 V | | t _{LEAD} | -30 + N × t _{SPcyc} ^{*2} | — | ns | |
| | | | 1.6 V ≤ VCC < 1.8 V | | | -50 + N × t _{SPcyc} ^{*2} | — | | |
| | Slave | | | 6 × t _{Pcyc} | — | ns | | | |
| | SSL hold time | Master | | t _{LAG} | -30 + N × t _{SPcyc} ^{*3} | — | ns | | |
| Slave | | 6 × t _{Pcyc} | — | | ns | | | | |
| Data output delay time | | Master | 2.7 V ≤ VCC ≤ 5.5 V | | t _{OD} | — | 14 | ns | |
| | | | 2.4 V ≤ VCC < 2.7 V | | | — | 20 | | |
| | | | 1.8 V ≤ VCC < 2.4 V | | | — | 25 | | |
| | | | 1.6 V ≤ VCC < 1.8 V | | | — | 30 | | |
| | | Slave | 2.7 V ≤ VCC ≤ 5.5 V | | | — | 50 | | |
| | | | 2.4 V ≤ VCC < 2.7 V | | | — | 60 | | |
| | | | 1.8 V ≤ VCC < 2.4 V | | | — | 85 | | |
| | | | 1.6 V ≤ VCC < 1.8 V | | | — | 110 | | |
| Data output hold time | Master | | t _{OH} | 0 | — | ns | | | |
| | Slave | | | 0 | — | | | | |
| Successive transmission delay time | Master | | t _{TD} | t _{SPcyc} + 2 × t _{Pcyc} | 8 × t _{SPcyc} + 2 × t _{Pcyc} | ns | | | |
| | Slave | | | 6 × t _{Pcyc} | — | | | | |

Table 2.32 SPI timing (3 of 3)

| Parameter | | Symbol | Min | Max | Unit*1 | Test conditions | | | |
|---|---|--|--|--|---------------------------|---------------------------|--|----|--|
| SPI | MOSI and MISO rise and fall time | Output | $2.7\text{ V} \leq \text{VCC} \leq 5.5\text{ V}$ | t_{Dr}, t_{Df} | — | 10 | Figure 2.29 to Figure 2.34 C = 30 pF | | |
| | | | $2.4\text{ V} \leq \text{VCC} < 2.7\text{ V}$ | — | 15 | | | | |
| | | | $1.8\text{ V} \leq \text{VCC} < 2.4\text{ V}$ | — | 20 | | | | |
| | | | $1.6\text{ V} \leq \text{VCC} < 1.8\text{ V}$ | — | 30 | | | | |
| | | Input | | — | 1 | μs | | | |
| | | SSL rise and fall time | Output | $2.7\text{ V} \leq \text{VCC} \leq 5.5\text{ V}$ | t_{SSLr}, t_{SSLf} | — | | 10 | Figure 2.33 and Figure 2.34 C = 30 pF |
| | | | | $2.4\text{ V} \leq \text{VCC} < 2.7\text{ V}$ | — | 15 | | | |
| | | | | $1.8\text{ V} \leq \text{VCC} < 2.4\text{ V}$ | — | 20 | | | |
| | $1.6\text{ V} \leq \text{VCC} < 1.8\text{ V}$ | | | — | 30 | | | | |
| | Input | | — | 1 | μs | | | | |
| | Slave access time | | $2.4\text{ V} \leq \text{VCC} \leq 5.5\text{ V}$ | t_{SA} | — | $2 \times t_{Pcyc} + 100$ | Figure 2.33 and Figure 2.34 C = 30 pF | | |
| | | | $1.8\text{ V} \leq \text{VCC} < 2.4\text{ V}$ | — | $2 \times t_{Pcyc} + 140$ | | | | |
| $1.6\text{ V} \leq \text{VCC} < 1.8\text{ V}$ | | | — | $2 \times t_{Pcyc} + 180$ | | | | | |
| Slave output release time | | $2.4\text{ V} \leq \text{VCC} \leq 5.5\text{ V}$ | t_{REL} | — | $2 \times t_{Pcyc} + 100$ | ns | | | |
| | | $1.8\text{ V} \leq \text{VCC} < 2.4\text{ V}$ | — | $2 \times t_{Pcyc} + 140$ | | | | | |
| | | $1.6\text{ V} \leq \text{VCC} < 1.8\text{ V}$ | — | $2 \times t_{Pcyc} + 180$ | | | | | |

Note 1. t_{Pcyc} : PCLKB cycle.

Note 2. N is set as an integer from 1 to 8 by the SPCKD register.

Note 3. N is set as an integer from 1 to 8 by the SSLND register.

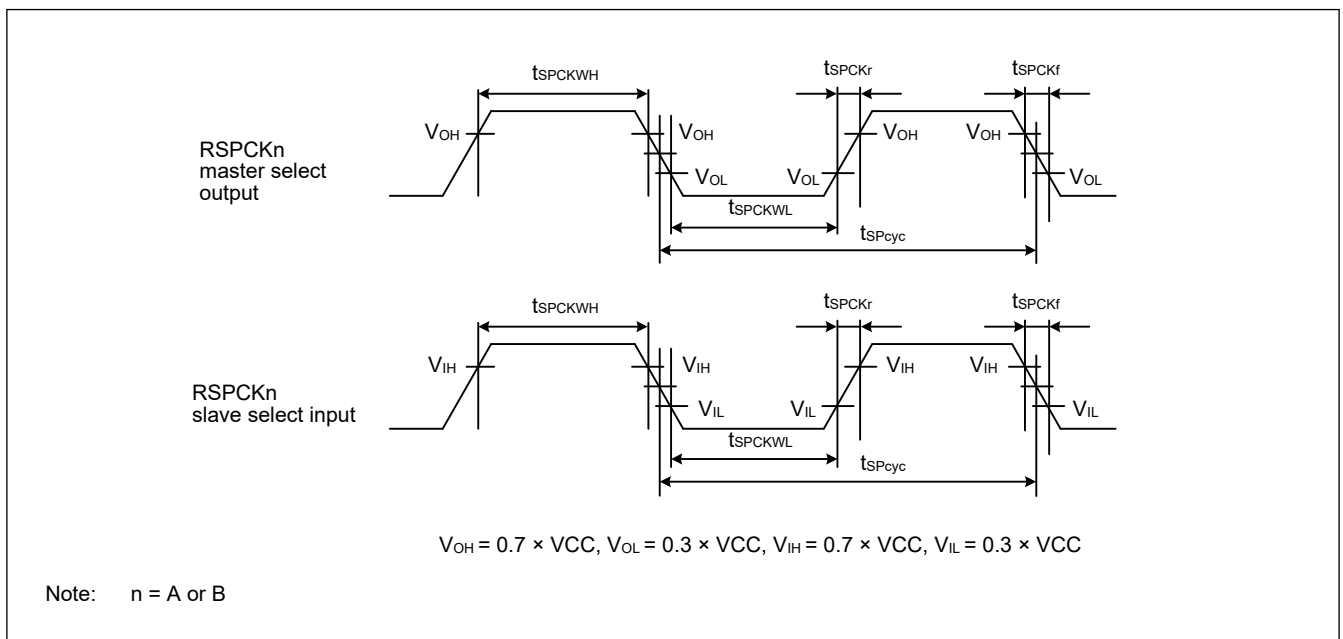

Figure 2.28 SPI clock timing

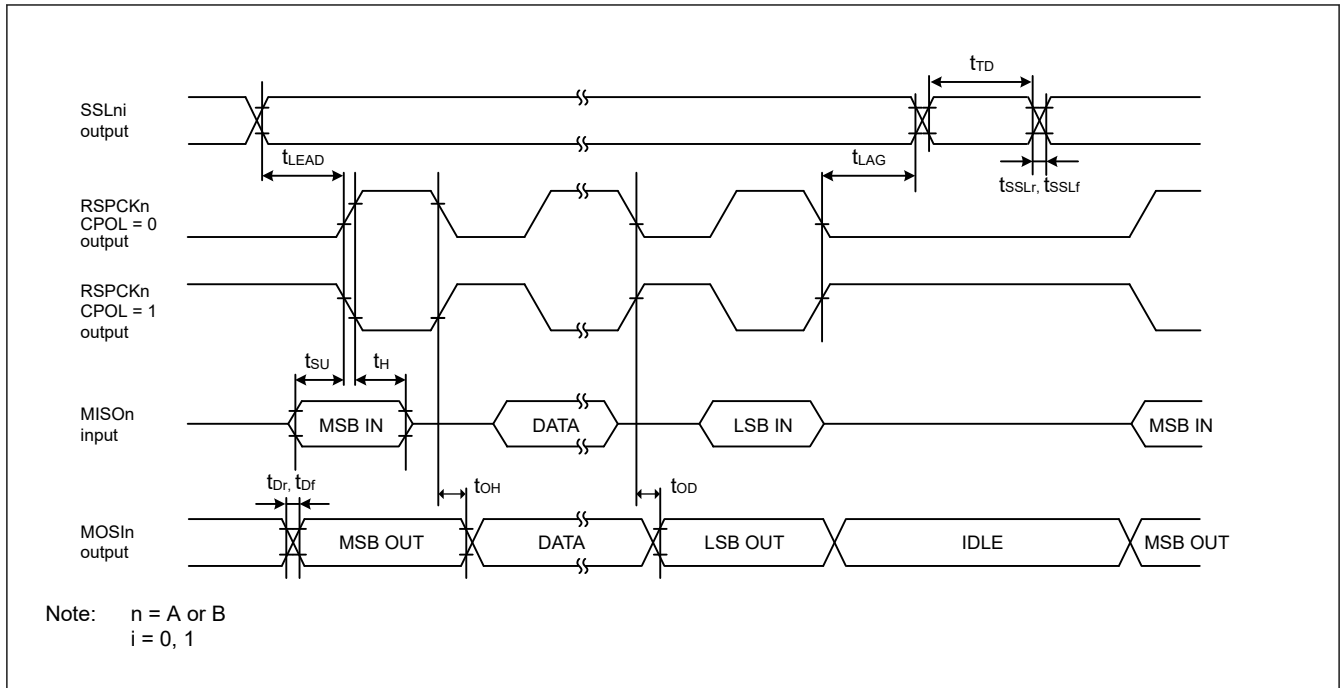

Figure 2.29 SPI timing (master, CPHA = 0) (bit rate: PCLKB division ratio is set to any value other than 1/2)

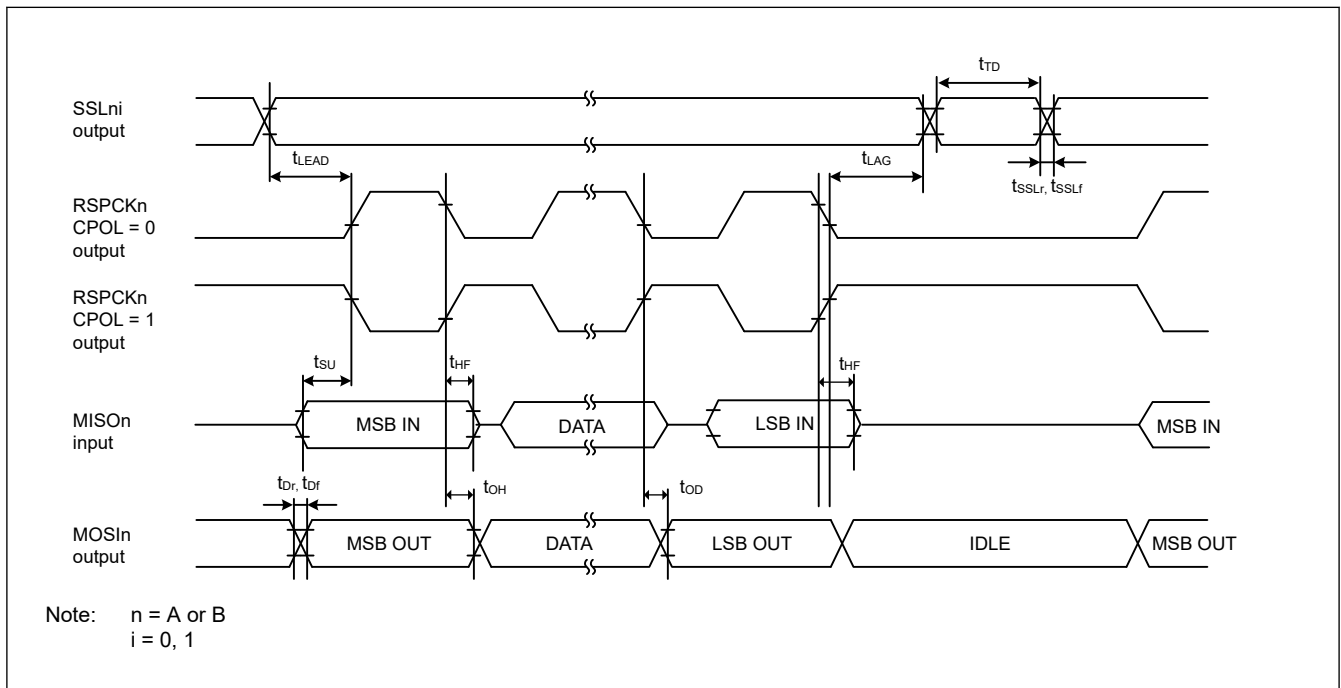

Figure 2.30 SPI timing (master, CPHA = 0) (bit rate: PCLKB division ratio is set to 1/2)

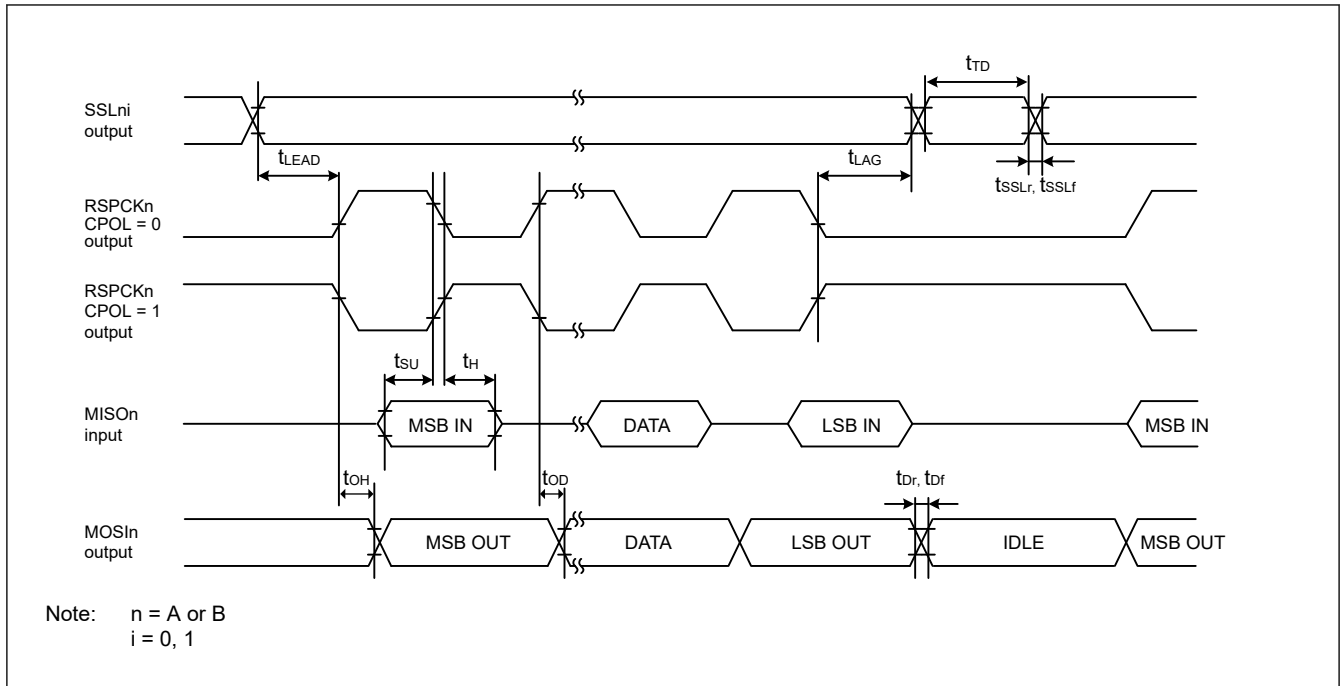

Figure 2.31 SPI timing (master, CPHA = 1) (bit rate: PCLKB division ratio is set to any value other than 1/2)

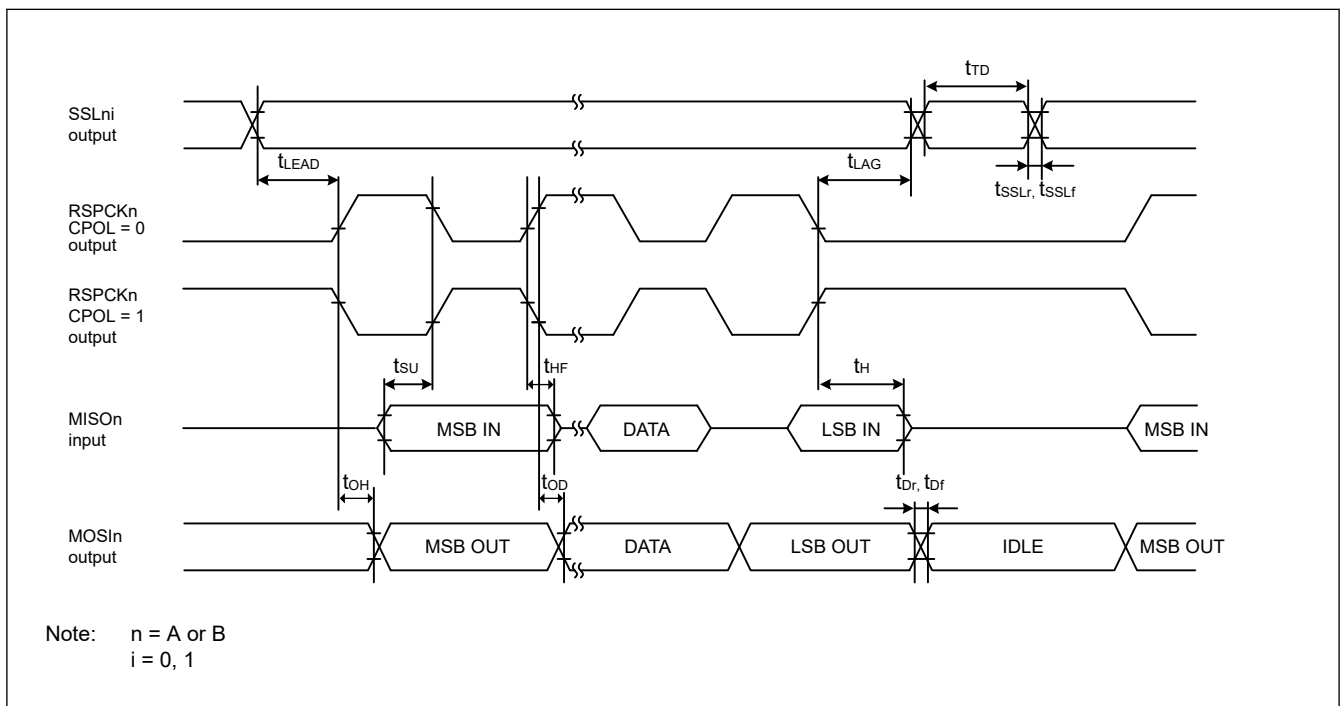

Figure 2.32 SPI timing (master, CPHA = 1) (bit rate: PCLKB division ratio is set to 1/2)

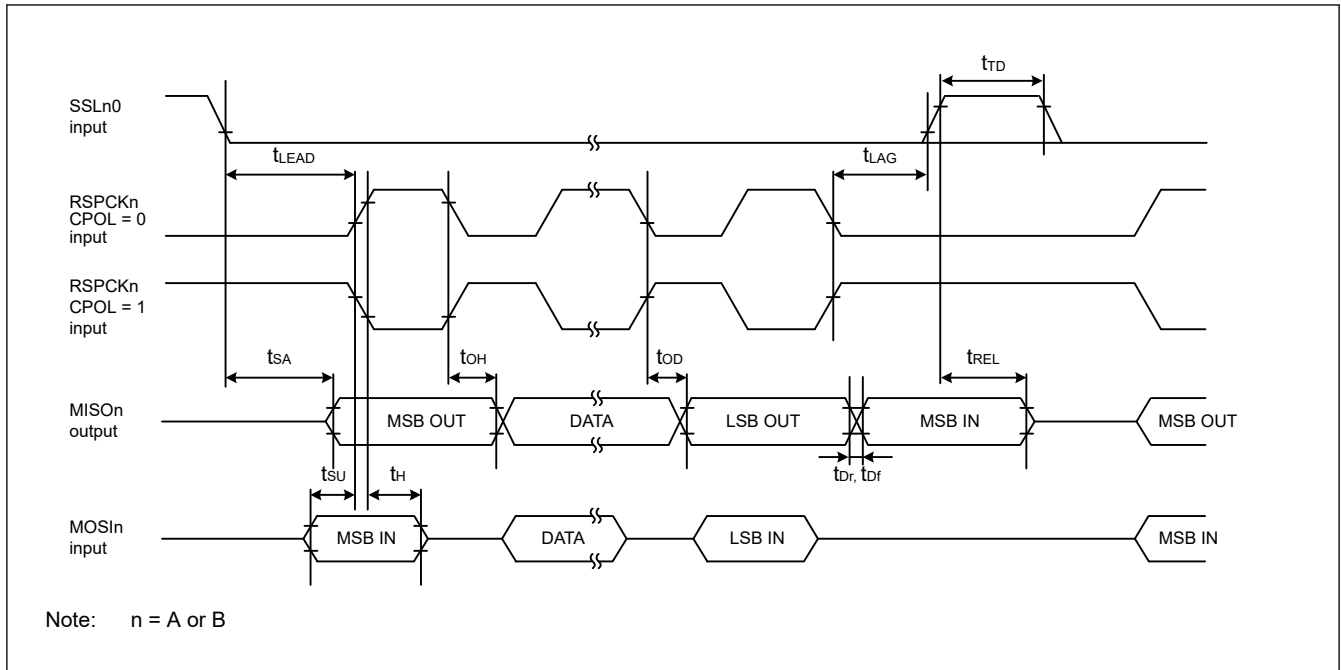

Figure 2.33 SPI timing (slave, CPHA = 0)

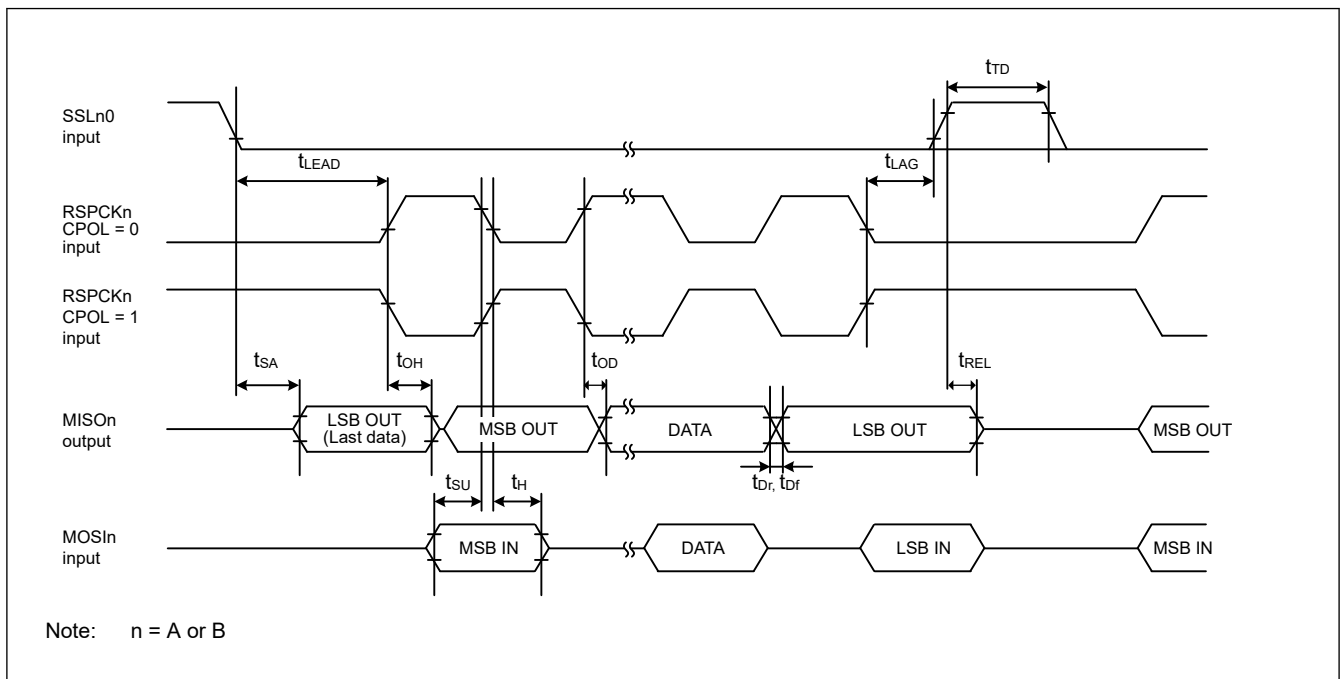

Figure 2.34 SPI timing (slave, CPHA = 1)

2.3.10 IIC Timing

Table 2.33 IIC timing

Conditions: VCC = AVCC0 = 2.7 to 5.5 V

| Parameter | Symbol | Min*1 | Max | Unit | Test conditions | |
|----------------------------|--|------------|---|---------------------------|-----------------|-------------|
| IIC (standard mode, SMBus) | SCL input cycle time | t_{SCL} | $6 (12) \times t_{IICcyc} + 1300$ | — | ns | Figure 2.35 |
| | SCL input high pulse width | t_{SCLH} | $3 (6) \times t_{IICcyc} + 300$ | — | ns | |
| | SCL input low pulse width | t_{SCLL} | $3 (6) \times t_{IICcyc} + 300$ | — | ns | |
| | SCL, SDA input rise time | t_{Sr} | — | 1000 | ns | |
| | SCL, SDA input fall time | t_{Sf} | — | 300 | ns | |
| | SCL, SDA input spike pulse removal time | t_{SP} | 0 | $1 (4) \times t_{IICcyc}$ | ns | |
| | SDA input bus free time (when wakeup function is disabled) | t_{BUF} | $3 (6) \times t_{IICcyc} + 300$ | — | ns | |
| | SDA input bus free time (when wakeup function is enabled) | t_{BUF} | $3 (6) \times t_{IICcyc} + 4 \times t_{Pcyc} + 300$ | — | ns | |
| | START condition input hold time (when wakeup function is disabled) | t_{STAH} | $t_{IICcyc} + 300$ | — | ns | |
| | START condition input hold time (when wakeup function is enabled) | t_{STAH} | $1 (5) \times t_{IICcyc} + t_{Pcyc} + 300$ | — | ns | |
| | Repeated START condition input setup time | t_{STAS} | 1000 | — | ns | |
| | STOP condition input setup time | t_{STOS} | 1000 | — | ns | |
| | Data input setup time | t_{SDAS} | $t_{IICcyc} + 50$ | — | ns | |
| | Data input hold time | t_{SDAH} | 0 | — | ns | |
| | SCL, SDA capacitive load | C_b | — | 400 | pF | |
| IIC (Fast mode) | SCL input cycle time | t_{SCL} | $6 (12) \times t_{IICcyc} + 600$ | — | ns | Figure 2.35 |
| | SCL input high pulse width | t_{SCLH} | $3 (6) \times t_{IICcyc} + 300$ | — | ns | |
| | SCL input low pulse width | t_{SCLL} | $3 (6) \times t_{IICcyc} + 300$ | — | ns | |
| | SCL, SDA input rise time | t_{Sr} | — | 300 | ns | |
| | SCL, SDA input fall time | t_{Sf} | — | 300 | ns | |
| | SCL, SDA input spike pulse removal time | t_{SP} | 0 | $1 (4) \times t_{IICcyc}$ | ns | |
| | SDA input bus free time (When wakeup function is disabled) | t_{BUF} | $3 (6) \times t_{IICcyc} + 300$ | — | ns | |
| | SDA input bus free time (When wakeup function is enabled) | t_{BUF} | $3 (6) \times t_{IICcyc} + 4 \times t_{Pcyc} + 300$ | — | ns | |
| | START condition input hold time (When wakeup function is disabled) | t_{STAH} | $t_{IICcyc} + 300$ | — | ns | |
| | START condition input hold time (When wakeup function is enabled) | t_{STAH} | $1 (5) \times t_{IICcyc} + t_{Pcyc} + 300$ | — | ns | |
| | Repeated START condition input setup time | t_{STAS} | 300 | — | ns | |
| | STOP condition input setup time | t_{STOS} | 300 | — | ns | |
| | Data input setup time | t_{SDAS} | $t_{IICcyc} + 50$ | — | ns | |
| | Data input hold time | t_{SDAH} | 0 | — | ns | |
| | SCL, SDA capacitive load | C_b | — | 400 | pF | |

Note: t_{IICcyc} : IIC internal reference clock (IIC ϕ) cycle, t_{Pcyc} : PCLKB cycle

Note 1. Values in parentheses apply when ICMR3.NF[1:0] is set to 11b while the digital filter is enabled with ICFER.NFE set to 1.

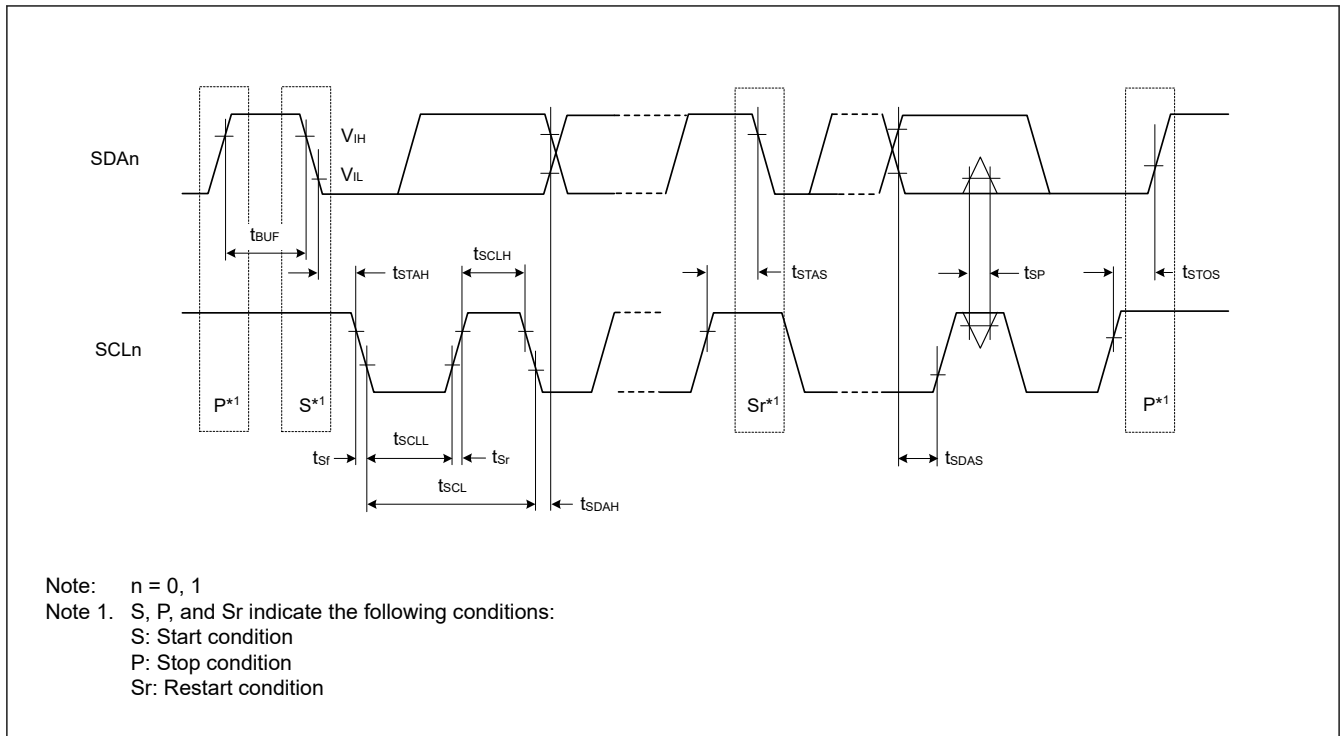

Figure 2.35 I²C bus interface input/output timing

2.3.11 CLKOUT Timing

Table 2.34 CLKOUT timing

| Parameter | | Symbol | Min | Max | Unit | Test conditions | |
|---|---------------------------------------|-----------|--|------|------|-----------------|-------------|
| CLKOUT | CLKOUT pin output cycle* ¹ | t_{Cyc} | $2.7\text{ V} \leq V_{CC} \leq 5.5\text{ V}$ | 62.5 | — | ns | Figure 2.36 |
| | | | $1.8\text{ V} \leq V_{CC} < 2.7\text{ V}$ | 125 | — | | |
| | | | $1.6\text{ V} \leq V_{CC} < 1.8\text{ V}$ | 250 | — | | |
| CLKOUT pin high pulse width* ² | | t_{CH} | $2.7\text{ V} \leq V_{CC} \leq 5.5\text{ V}$ | 15 | — | ns | |
| | | | $1.8\text{ V} \leq V_{CC} < 2.7\text{ V}$ | 30 | — | | |
| | | | $1.6\text{ V} \leq V_{CC} < 1.8\text{ V}$ | 150 | — | | |
| CLKOUT pin low pulse width* ² | | t_{CL} | $2.7\text{ V} \leq V_{CC} \leq 5.5\text{ V}$ | 15 | — | ns | |
| | | | $1.8\text{ V} \leq V_{CC} < 2.7\text{ V}$ | 30 | — | | |
| | | | $1.6\text{ V} \leq V_{CC} < 1.8\text{ V}$ | 150 | — | | |
| CLKOUT pin output rise time | | t_{Cr} | $2.7\text{ V} \leq V_{CC} \leq 5.5\text{ V}$ | — | 12 | ns | |
| | | | $1.8\text{ V} \leq V_{CC} < 2.7\text{ V}$ | — | 25 | | |
| | | | $1.6\text{ V} \leq V_{CC} < 1.8\text{ V}$ | — | 50 | | |
| CLKOUT pin output fall time | | t_{Cf} | $2.7\text{ V} \leq V_{CC} \leq 5.5\text{ V}$ | — | 12 | ns | |
| | | | $1.8\text{ V} \leq V_{CC} < 2.7\text{ V}$ | — | 25 | | |
| | | | $1.6\text{ V} \leq V_{CC} < 1.8\text{ V}$ | — | 50 | | |

Note 1. When the EXTAL external clock input or an oscillator is used with division by 1 (the CKOCR.CKOSSEL[2:0] bits are 011b and the CKOCR.CKODIV[2:0] bits are 000b) to output from CLKOUT, specifications in Table 2.34 should be satisfied with 45% to 55% of input duty cycle.

Note 2. When MOCO is selected as the clock output source (the CKOCR.CKOSSEL[2:0] bits are 001b), set the clock output division ratio to be divided by 2 (the CKOCR.CKODIV[2:0] bits are 001b).

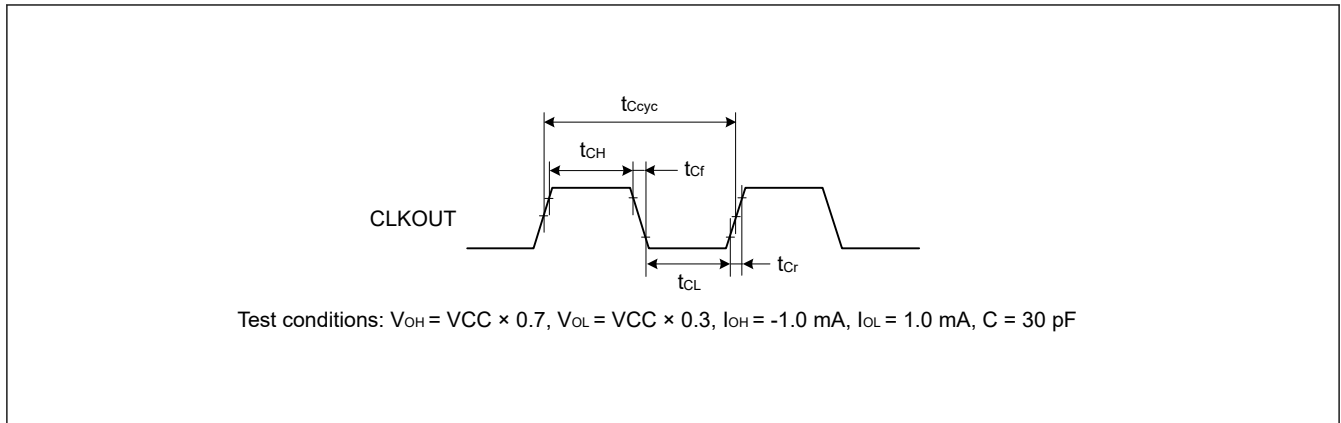

Figure 2.36 CLKOUT output timing

2.4 ADC12 Characteristics

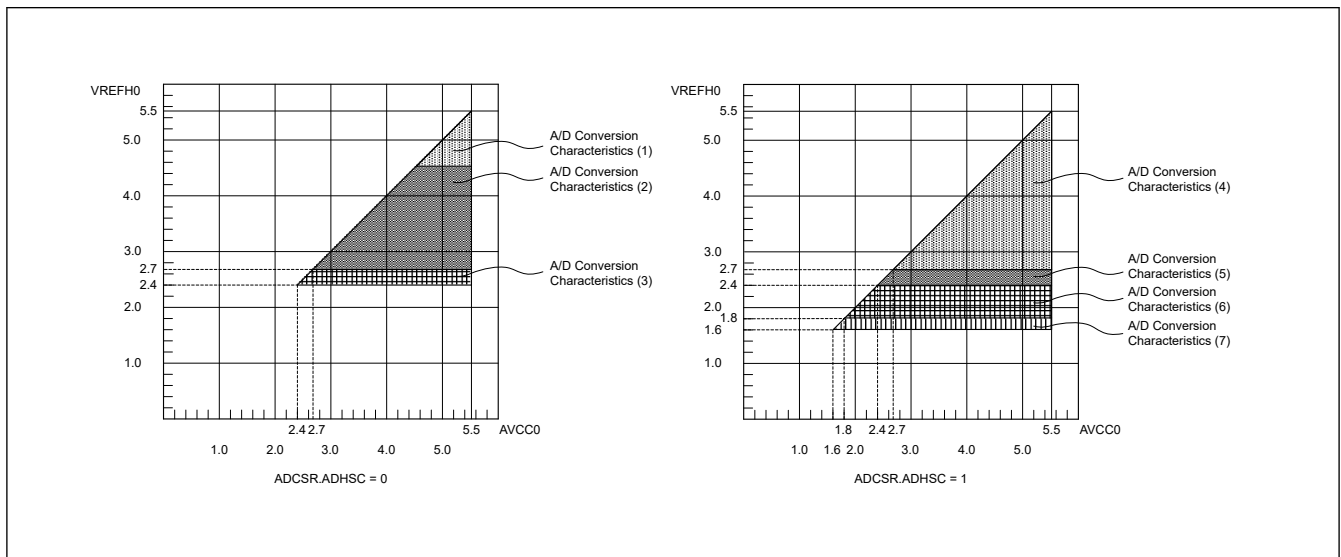

Figure 2.37 AVCC0 to VREFH0 voltage range

Table 2.35 A/D conversion characteristics (1) in high-speed A/D conversion mode (1 of 2)

Conditions: $V_{CC} = AV_{CC0} = V_{REFH0} = 4.5 \text{ to } 5.5 \text{ V}^{*5}$, $V_{SS} = AV_{SS0} = V_{REFL0} = 0 \text{ V}$
 Reference voltage range applied to the VREFH0 and VREFL0.

| Parameter | Min | Typ | Max | Unit | Test conditions |
|----------------------------|-----|-----|------------|------|--------------------------|
| PCLKD (ADCLK) frequency | 1 | — | 64 | MHz | ADACSR.ADSAC = 0 |
| | | | 48 | MHz | ADACSR.ADSAC = 1 |
| Analog input capacitance*2 | Cs | — | 9^{*3} | pF | High-precision channel |
| | | | 10^{*3} | pF | Normal-precision channel |
| Analog input resistance | Rs | — | 1.3^{*3} | kΩ | High-precision channel |
| | | | 5.0^{*3} | kΩ | Normal-precision channel |
| Analog input voltage range | Ain | 0 | VREFH0 | V | — |
| Resolution | — | — | 12 | Bit | — |

Table 2.35 A/D conversion characteristics (1) in high-speed A/D conversion mode (2 of 2)

Conditions: VCC = AVCC0 = VREFH0 = 4.5 to 5.5 V^{*5}, VSS = AVSS0 = VREFL0 = 0 V
Reference voltage range applied to the VREFH0 and VREFL0.

| Parameter | | Min | Typ | Max | Unit | Test conditions |
|--|--|-------------------------------|------|------|------|--|
| Conversion time ^{*1} (Operation at PCLKD = 64 MHz) | Permissible signal source impedance Max. = 0.3 kΩ | 0.70 (0.211) ^{*4} | — | — | μs | High-precision channel ADCSR.ADHSC = 0 ADSSTRn.SST[7:0] = 0x0D ADACSR.ADSAC = 0 |
| | | 1.34 (0.852) ^{*4} | — | — | μs | Normal-precision channel ADCSR.ADHSC = 0 ADSSTRn.SST[7:0] = 0x36 ADACSR.ADSAC = 0 |
| Conversion time ^{*1} (Operation at PCLKD = 48 MHz) | Permissible signal source impedance Max. = 0.3 kΩ | 0.67 (0.219) ^{*4} | — | — | μs | High-precision channel ADCSR.ADHSC = 0 ADSSTRn.SST[7:0] = 0x0A ADACSR.ADSAC = 1 |
| | | 1.29 (0.844) ^{*4} | — | — | μs | Normal-precision channel ADCSR.ADHSC = 0 ADSSTRn.SST[7:0] = 0x28 ADACSR.ADSAC = 1 |
| Offset error | | — | ±1.0 | ±4.5 | LSB | High-precision channel |
| | | | | ±6.0 | LSB | Other than specified |
| Full-scale error | | — | ±1.0 | ±4.5 | LSB | High-precision channel |
| | | | | ±6.0 | LSB | Other than specified |
| Quantization error | | — | ±0.5 | — | LSB | — |
| Absolute accuracy | | — | ±2.5 | ±5.0 | LSB | High-precision channel |
| | | | | ±8.0 | LSB | Other than specified |
| DNL differential nonlinearity error | | — | ±1.0 | — | LSB | — |
| INL integral nonlinearity error | | — | ±1.5 | ±3.0 | LSB | — |

Note: The characteristics apply when no pin functions other than 12-bit A/D converter input are used. Absolute accuracy does not include quantization errors. Offset error, full-scale error, DNL differential nonlinearity error, and INL integral nonlinearity error do not include quantization errors.

Note 1. The conversion time is the sum of the sampling time and the comparison time. The number of sampling states is indicated for the test conditions.

Note 2. Except for I/O input capacitance (C_{in}), see [section 2.2.4. I/O VOH, VOL, and Other Characteristics](#).

Note 3. Reference data.

Note 4. () lists sampling time.

Note 5. When VREFH0 < AVCC0, the MAX. values are as follows.

Absolute accuracy/Offset error/Full-scale error:

For voltage difference between AVCC0 and VREFH0, it should be added ±0.75 LSB/V to the Max spec.

INL integral non-linearity error:

For voltage difference between AVCC0 and VREFH0, it should be added ±0.2 LSB/V to the Max spec.

Table 2.36 A/D conversion characteristics (2) in high-speed A/D conversion mode (1 of 2)

Conditions: VCC = AVCC0 = VREFH0 = 2.7 to 5.5 V^{*5}, VSS = AVSS0 = VREFL0 = 0 V
Reference voltage range applied to the VREFH0 and VREFL0.

| Parameter | | Min | Typ | Max | Unit | Test conditions |
|--|-----------------|-----|-----|-------------------|------|--------------------------|
| PCLKD (ADCLK) frequency | | 1 | — | 48 | MHz | — |
| Analog input capacitance ^{*2} | Cs | — | — | 9 ^{*3} | pF | High-precision channel |
| | | — | — | 10 ^{*3} | pF | Normal-precision channel |
| Analog input resistance | Rs | — | — | 1.9 ^{*3} | kΩ | High-precision channel |
| | | — | — | 6.0 ^{*3} | kΩ | Normal-precision channel |
| Analog input voltage range | A _{in} | 0 | — | VREFH0 | V | — |
| Resolution | | — | — | 12 | Bit | — |

Table 2.36 A/D conversion characteristics (2) in high-speed A/D conversion mode (2 of 2)

Conditions: VCC = AVCC0 = VREFH0 = 2.7 to 5.5 V^{*5}, VSS = AVSS0 = VREFL0 = 0 V
Reference voltage range applied to the VREFH0 and VREFL0.

| Parameter | | Min | Typ | Max | Unit | Test conditions |
|--|--|-------------------------------|------|------|------|--|
| Conversion time ^{*1} (Operation at PCLKD = 48 MHz) | Permissible signal source impedance Max. = 0.3 kΩ | 0.67 (0.219) ^{*4} | — | — | μs | High-precision channel ADCSR.ADHSC = 0 ADSSTRn.SST[7:0] = 0x0A ADACSR.ADSAC = 1 |
| | | 1.29 (0.844) ^{*4} | — | — | μs | Normal-precision channel ADCSR.ADHSC = 0 ADSSTRn.SST[7:0] = 0x28 ADACSR.ADSAC = 1 |
| Offset error | | — | ±1.0 | ±5.5 | LSB | High-precision channel |
| | | | | ±7.0 | LSB | Other than specified |
| Full-scale error | | — | ±1.0 | ±5.5 | LSB | High-precision channel |
| | | | | ±7.0 | LSB | Other than specified |
| Quantization error | | — | ±0.5 | — | LSB | — |
| Absolute accuracy | | — | ±2.5 | ±6.0 | LSB | High-precision channel |
| | | | | ±9.0 | LSB | Other than specified |
| DNL differential nonlinearity error | | — | ±1.0 | — | LSB | — |
| INL integral nonlinearity error | | — | ±1.5 | ±3.0 | LSB | — |

Note: The characteristics apply when no pin functions other than 12-bit A/D converter input are used. Absolute accuracy does not include quantization errors. Offset error, full-scale error, DNL differential nonlinearity error, and INL integral nonlinearity error do not include quantization errors.

Note 1. The conversion time is the sum of the sampling time and the comparison time. The number of sampling states is indicated for the test conditions.

Note 2. Except for I/O input capacitance (C_{in}), see [section 2.2.4. I/O VOH, VOL, and Other Characteristics](#).

Note 3. Reference data.

Note 4. () lists sampling time.

Note 5. When VREFH0 < AVCC0, the MAX. values are as follows.

Absolute accuracy/Offset error/Full-scale error:

For voltage difference between AVCC0 and VREFH0, it should be added ±0.75 LSB/V to the Max spec.

INL integral non-linearity error:

For voltage difference between AVCC0 and VREFH0, it should be added ±0.2 LSB/V to the Max spec.

Table 2.37 A/D conversion characteristics (3) in high-speed A/D conversion mode (1 of 2)

Conditions: VCC = AVCC0 = VREFH0 = 2.4 to 5.5 V^{*5}, VSS = AVSS0 = VREFL0 = 0 V
Reference voltage range applied to the VREFH0 and VREFL0.

| Parameter | | Min | Typ | Max | Unit | Test conditions |
|--|--|-------------------------------|-----|-------------------|------|--|
| PCLKD (ADCLK) frequency | | 1 | — | 32 | MHz | — |
| Analog input capacitance ^{*2} | Cs | — | — | 9 ^{*3} | pF | High-precision channel |
| | | — | — | 10 ^{*3} | pF | Normal-precision channel |
| Analog input resistance | Rs | — | — | 2.2 ^{*3} | kΩ | High-precision channel |
| | | — | — | 7.0 ^{*3} | kΩ | Normal-precision channel |
| Analog input voltage range | A _{in} | 0 | — | VREFH0 | V | — |
| Resolution | | — | — | 12 | Bit | — |
| Conversion time ^{*1} (Operation at PCLKD = 32 MHz) | Permissible signal source impedance Max. = 1.3 kΩ | 1.00 (0.328) ^{*4} | — | — | μs | High-precision channel ADCSR.ADHSC = 0 ADSSTRn.SST[7:0] = 0x0A ADACSR.ADSAC = 1 |
| | | 1.94 (1.266) ^{*4} | — | — | μs | Normal-precision channel ADCSR.ADHSC = 0 ADSSTRn.SST[7:0] = 0x28 ADACSR.ADSAC = 1 |

Table 2.37 A/D conversion characteristics (3) in high-speed A/D conversion mode (2 of 2)

Conditions: VCC = AVCC0 = VREFH0 = 2.4 to 5.5 V^{*5}, VSS = AVSS0 = VREFL0 = 0 V
Reference voltage range applied to the VREFH0 and VREFL0.

| Parameter | Min | | Max | Unit | Test conditions |
|-------------------------------------|-----|-------|------|------|------------------------|
| Offset error | — | ±1.0 | ±5.5 | LSB | High-precision channel |
| | | | ±7.0 | LSB | Other than specified |
| Full-scale error | — | ±1.0 | ±5.5 | LSB | High-precision channel |
| | | | ±7.0 | LSB | Other than specified |
| Quantization error | — | ±0.5 | — | LSB | — |
| Absolute accuracy | — | ±2.50 | ±6.0 | LSB | High-precision channel |
| | | | ±9.0 | LSB | Other than specified |
| DNL differential nonlinearity error | — | ±1.0 | — | LSB | — |
| INL integral nonlinearity error | — | ±1.5 | ±3.0 | LSB | — |

Note: The characteristics apply when no pin functions other than 12-bit A/D converter input are used. Absolute accuracy does not include quantization errors. Offset error, full-scale error, DNL differential nonlinearity error, and INL integral nonlinearity error do not include quantization errors.

Note 1. The conversion time is the sum of the sampling time and the comparison time. The number of sampling states is indicated for the test conditions.

Note 2. Except for I/O input capacitance (Cin), see [section 2.2.4. I/O VOH, VOL, and Other Characteristics](#).

Note 3. Reference data.

Note 4. () lists sampling time.

Note 5. When VREFH0 < AVCC0, the MAX. values are as follows.

Absolute accuracy/Offset error/Full-scale error:

For voltage difference between AVCC0 and VREFH0, it should be added ±0.75 LSB/V to the Max spec.

INL integral non-linearity error:

For voltage difference between AVCC0 and VREFH0, it should be added ±0.2 LSB/V to the Max spec.

Table 2.38 A/D conversion characteristics (4) in low-power A/D conversion mode (1 of 2)

Conditions: VCC = AVCC0 = VREFH0 = 2.7 to 5.5 V^{*5}, VSS = AVSS0 = VREFL0 = 0 V
Reference voltage range applied to the VREFH0 and VREFL0.

| Parameter | Min | Typ | Max | Unit | Test conditions | |
|--|--|----------------------------|-------------------|------|--------------------------|--|
| PCLKD (ADCLK) frequency | 1 | — | 24 | MHz | — | |
| Analog input capacitance ^{*2} | Cs | — | 9 ^{*3} | pF | High-precision channel | |
| | | | 10 ^{*3} | pF | Normal-precision channel | |
| Analog input resistance | Rs | — | 1.9 ^{*3} | kΩ | High-precision channel | |
| | | | 6 ^{*3} | kΩ | Normal-precision channel | |
| Analog input voltage range | Ain | 0 | VREFH0 | V | — | |
| Resolution | — | — | 12 | Bit | — | |
| Conversion time ^{*1} (Operation at PCLKD = 24 MHz) | Permissible signal source impedance Max. = 1.1 kΩ | 1.58 (0.438) ^{*4} | — | — | μs | High-precision channel ADCSR.ADHSC = 1 ADSSTRn.SST[7:0] = 0x0A ADACSR.ADSAC = 1 |
| | | 2.0 (0.854) ^{*4} | — | — | μs | Normal-precision channel ADCSR.ADHSC = 1 ADSSTRn.SST[7:0] = 0x14 ADACSR.ADSAC = 1 |
| Offset error | — | ±1.25 | ±6.0 | LSB | High-precision channel | |
| | | | ±7.5 | LSB | Other than specified | |
| Full-scale error | — | ±1.25 | ±6.0 | LSB | High-precision channel | |
| | | | ±7.5 | LSB | Other than specified | |
| Quantization error | — | ±0.5 | — | LSB | — | |

Table 2.38 A/D conversion characteristics (4) in low-power A/D conversion mode (2 of 2)

Conditions: VCC = AVCC0 = VREFH0 = 2.7 to 5.5 V^{*5}, VSS = AVSS0 = VREFL0 = 0 V
Reference voltage range applied to the VREFH0 and VREFL0.

| Parameter | Min | Typ | Max | Unit | Test conditions |
|-------------------------------------|-----|-------|-------|------|------------------------|
| Absolute accuracy | — | ±3.25 | ±7.0 | LSB | High-precision channel |
| | | | ±10.0 | LSB | Other than specified |
| DNL differential nonlinearity error | — | ±1.5 | — | LSB | — |
| INL integral nonlinearity error | — | ±1.75 | ±4.0 | LSB | — |

Note: The characteristics apply when no pin functions other than 12-bit A/D converter input are used. Absolute accuracy does not include quantization errors. Offset error, full-scale error, DNL differential nonlinearity error, and INL integral nonlinearity error do not include quantization errors.

Note 1. The conversion time is the sum of the sampling time and the comparison time. The number of sampling states is indicated for the test conditions.

Note 2. Except for I/O input capacitance (C_{in}), see [section 2.2.4. I/O VOH, VOL, and Other Characteristics](#).

Note 3. Reference data.

Note 4. () lists sampling time.

Note 5. When VREFH0 < AVCC0, the MAX. values are as follows.

Absolute accuracy/Offset error/Full-scale error:

For voltage difference between AVCC0 and VREFH0, it should be added ±0.75 LSB/V to the Max spec.

INL integral non-linearity error:

For voltage difference between AVCC0 and VREFH0, it should be added ±0.2 LSB/V to the Max spec.

Table 2.39 A/D conversion characteristics (5) in low-power A/D conversion mode

Conditions: VCC = AVCC0 = VREFH0 = 2.4 to 5.5 V^{*5}, VSS = AVSS0 = VREFL0 = 0 V
Reference voltage range applied to the VREFH0 and VREFL0.

| Parameter | Min | Typ | Max | Unit | Test conditions | |
|--|--|-------------------------------|-------------------|------|--------------------------|--|
| PCLKD (ADCLK) frequency | 1 | — | 16 | MHz | — | |
| Analog input capacitance*2 | Cs | — | 9 ^{*3} | pF | High-precision channel | |
| | | | 10 ^{*3} | pF | Normal-precision channel | |
| Analog input resistance | Rs | — | 2.2 ^{*3} | kΩ | High-precision channel | |
| | | | 7 ^{*3} | kΩ | Normal-precision channel | |
| Analog input voltage range | Ain | 0 | VREFH0 | V | — | |
| Resolution | — | — | 12 | Bit | — | |
| Conversion time*1 (Operation at PCLKD = 16 MHz) | Permissible signal source impedance Max. = 2.2 kΩ | 2.38 (0.656) ^{*4} | — | — | μs | High-precision channel ADCSR.ADHSC = 1 ADSSTRn.SST[7:0] = 0x0A ADACSR.ADSAC = 1 |
| | | 3.0 (1.281) ^{*4} | — | — | μs | Normal-precision channel ADCSR.ADHSC = 1 ADSSTRn.SST[7:0] = 0x14 ADACSR.ADSAC = 1 |
| Offset error | — | ±1.25 | ±6.0 | LSB | High-precision channel | |
| | | | ±7.5 | LSB | Other than specified | |
| Full-scale error | — | ±1.25 | ±6.0 | LSB | High-precision channel | |
| | | | ±7.5 | LSB | Other than specified | |
| Quantization error | — | ±0.5 | — | LSB | — | |
| Absolute accuracy | — | ±3.25 | ±7.0 | LSB | High-precision channel | |
| | | | ±10.0 | LSB | Other than specified | |
| DNL differential nonlinearity error | — | ±1.5 | — | LSB | — | |
| INL integral nonlinearity error | — | ±1.75 | ±4.0 | LSB | — | |

Note: The characteristics apply when no pin functions other than 12-bit A/D converter input are used. Absolute accuracy does not include quantization errors. Offset error, full-scale error, DNL differential nonlinearity error, and INL integral nonlinearity error do not include quantization errors.

- Note 1. The conversion time is the sum of the sampling time and the comparison time. The number of sampling states is indicated for the test conditions.
- Note 2. Except for I/O input capacitance (C_{in}), see [section 2.2.4. I/O VOH, VOL, and Other Characteristics](#).
- Note 3. Reference data.
- Note 4. () lists sampling time.
- Note 5. When VREFH0 < AVCC0, the MAX. values are as follows.
 Absolute accuracy/Offset error/Full-scale error:
 For voltage difference between AVCC0 and VREFH0, it should be added ±0.75 LSB/V to the Max spec.
 INL integral non-linearity error:
 For voltage difference between AVCC0 and VREFH0, it should be added ±0.2 LSB/V to the Max spec.

Table 2.40 A/D conversion characteristics (6) in low-power A/D conversion mode

Conditions: VCC = AVCC0 = VREFH0 = 1.8 to 5.5 V^{*5} (AVCC0 = VCC when VCC < 2.0 V), VSS = AVSS0 = VREFL0 = 0 V
 Reference voltage range applied to the VREFH0 and VREFL0.

| Parameter | | Min | Typ | Max | Unit | Test conditions |
|---|--|-------------------------------|-------|------------------|------|--|
| PCLKD (ADCLK) frequency | | 1 | — | 8 | MHz | — |
| Analog input capacitance ^{*2} | Cs | — | — | 9 ^{*3} | pF | High-precision channel |
| | | — | — | 10 ^{*3} | pF | Normal-precision channel |
| Analog input resistance | Rs | — | — | 6 ^{*3} | kΩ | High-precision channel |
| | | — | — | 14 ^{*3} | kΩ | Normal-precision channel |
| Analog input voltage range | Ain | 0 | — | VREFH0 | V | — |
| Resolution | | — | — | 12 | Bit | — |
| Conversion time ^{*1} (Operation at PCLKD = 8 MHz) | Permissible signal source impedance Max. = 5 kΩ | 4.75 (1.313) ^{*4} | — | — | μs | High-precision channel ADCSR.ADHSC = 1 ADSSTRn.SST[7:0] = 0x0A ADACSR.ADSAC = 1 |
| | | 6.0 (2.563) ^{*4} | — | — | μs | Normal-precision channel ADCSR.ADHSC = 1 ADSSTRn.SST[7:0] = 0x14 ADACSR.ADSAC = 1 |
| Offset error | | — | ±1.25 | ±7.5 | LSB | High-precision channel |
| | | | | ±10.0 | LSB | Other than specified |
| Full-scale error | | — | ±1.5 | ±7.5 | LSB | High-precision channel |
| | | | | ±10.0 | LSB | Other than specified |
| Quantization error | | — | ±0.5 | — | LSB | — |
| Absolute accuracy | | — | ±3.75 | ±9.5 | LSB | High-precision channel |
| | | | | ±13.5 | LSB | Other than specified |
| DNL differential nonlinearity error | | — | ±2.0 | — | LSB | — |
| INL integral nonlinearity error | | — | ±2.25 | ±4.5 | LSB | — |

- Note: The characteristics apply when no pin functions other than 12-bit A/D converter input are used. Absolute accuracy does not include quantization errors. Offset error, full-scale error, DNL differential nonlinearity error, and INL integral nonlinearity error do not include quantization errors.
- Note 1. The conversion time is the sum of the sampling time and the comparison time. The number of sampling states is indicated for the test conditions.
- Note 2. Except for I/O input capacitance (C_{in}), see [section 2.2.4. I/O VOH, VOL, and Other Characteristics](#).
- Note 3. Reference data.
- Note 4. () lists sampling time.
- Note 5. When VREFH0 < AVCC0, the MAX. values are as follows.
 Absolute accuracy/Offset error/Full-scale error:
 For voltage difference between AVCC0 and VREFH0, it should be added ±0.75 LSB/V to the Max spec.
 INL integral non-linearity error:
 For voltage difference between AVCC0 and VREFH0, it should be added ±0.2 LSB/V to the Max spec.

Table 2.41 A/D conversion characteristics (7) in low-power A/D conversion mode

Conditions: $V_{CC} = AVCC0 = VREFH0 = 1.6$ to $5.5 V^{*5}$ ($AVCC0 = V_{CC}$ when $V_{CC} < 2.0 V$), $V_{SS} = AVSS0 = VREFL0 = 0 V$
 Reference voltage range applied to the $VREFH0$ and $VREFL0$.

| Parameter | | Min | Typ | Max | Unit | Test conditions |
|---|--|----------------------------|-------|------------------|------|--|
| PCLKD (ADCLK) frequency | | 1 | — | 4 | MHz | — |
| Analog input capacitance ^{*2} | Cs | — | — | 9 ^{*3} | pF | High-precision channel |
| | | — | — | 10 ^{*3} | pF | Normal-precision channel |
| Analog input resistance | Rs | — | — | 12 ^{*3} | kΩ | High-precision channel |
| | | — | — | 28 ^{*3} | kΩ | Normal-precision channel |
| Analog input voltage range | Ain | 0 | — | VREFH0 | V | — |
| Resolution | | — | — | 12 | Bit | — |
| Conversion time ^{*1} (Operation at PCLKD = 4 MHz) | Permissible signal source impedance Max. = 9.9 kΩ | 9.5 (2.625) ^{*4} | — | — | μs | High-precision channel ADCSR.ADHSC = 1 ADSSTRn.SST[7:0] = 0x0A ADACSR.ADSAC = 1 |
| | | 12.0 (5.125) ^{*4} | — | — | μs | Normal-precision channel ADCSR.ADHSC = 1 ADSSTRn.SST[7:0] = 0x14 ADACSR.ADSAC = 1 |
| Offset error | | — | ±1.25 | ±7.5 | LSB | High-precision channel |
| | | | | ±10.0 | LSB | Other than specified |
| Full-scale error | | — | ±1.5 | ±7.5 | LSB | High-precision channel |
| | | | | ±10.0 | LSB | Other than specified |
| Quantization error | | — | ±0.5 | — | LSB | — |
| Absolute accuracy | | — | ±3.75 | ±9.5 | LSB | High-precision channel |
| | | | | ±13.5 | LSB | Other than specified |
| DNL differential nonlinearity error | | — | ±2.0 | — | LSB | — |
| INL integral nonlinearity error | | — | ±2.25 | ±4.5 | LSB | — |

Note: The characteristics apply when no pin functions other than 12-bit A/D converter input are used. Absolute accuracy does not include quantization errors. Offset error, full-scale error, DNL differential nonlinearity error, and INL integral nonlinearity error do not include quantization errors.

Note 1. The conversion time is the sum of the sampling time and the comparison time. The number of sampling states is indicated for the test conditions.

Note 2. Except for I/O input capacitance (Cin), see [section 2.2.4. I/O VOH, VOL, and Other Characteristics](#).

Note 3. Reference data.

Note 4. () lists sampling time.

Note 5. When $VREFH0 < AVCC0$, the MAX. values are as follows.

Absolute accuracy/Offset error/Full-scale error:

For voltage difference between $AVCC0$ and $VREFH0$, it should be added ± 0.75 LSB/V to the Max spec.

INL integral non-linearity error:

For voltage difference between $AVCC0$ and $VREFH0$, it should be added ± 0.2 LSB/V to the Max spec.

Figure 2.38 shows the equivalent circuit for analog input.

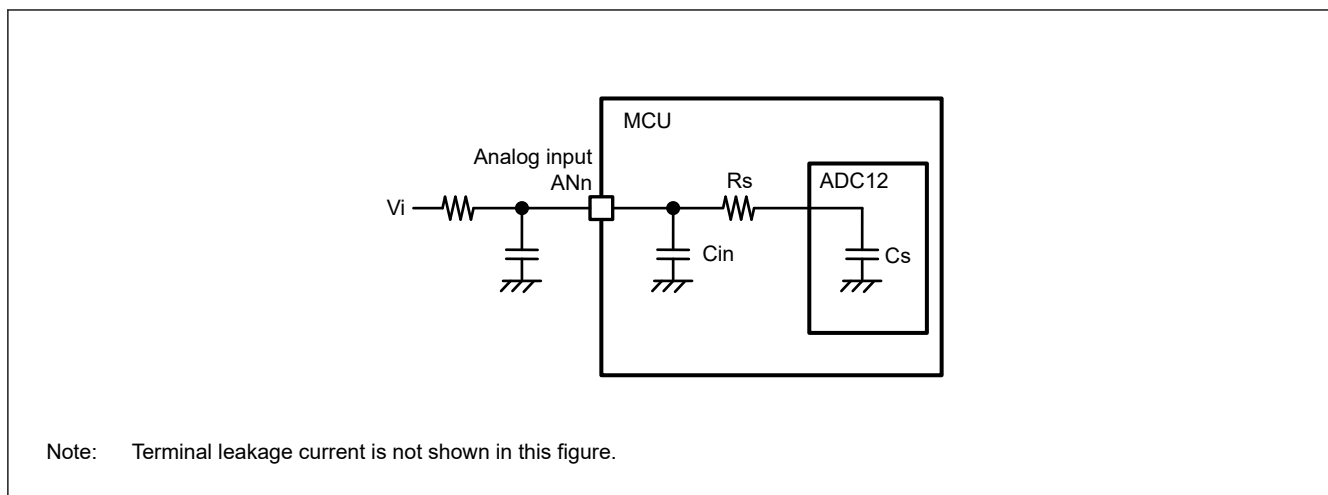

Figure 2.38 Equivalent circuit for analog input

Table 2.42 12-bit A/D converter channel classification

| Classification | Channel | Conditions | Remarks |
|--|----------------------------|----------------------|---|
| High-precision channel | AN000 to AN014 | AVCC0 = 1.6 to 5.5 V | Pins AN000 to AN014 cannot be used as general I/O, TS transmission, when the A/D converter is in use. |
| Normal-precision channel | AN017 to AN020 | | |
| Internal reference voltage input channel | Internal reference voltage | AVCC0 = 1.8 to 5.5 V | — |
| Temperature sensor input channel | Temperature sensor output | AVCC0 = 1.8 to 5.5 V | — |
| Input channel from CTSU | CTSU TSCAP voltage | AVCC0 = 1.6 to 5.5 V | — |

Table 2.43 A/D internal reference voltage characteristics

Conditions: VCC = AVCC0 = VREFH0 = 1.8 to 5.5 V^{*1}

| Parameter | Min | Typ | Max | Unit | Test conditions |
|--|------|------|------|------|-----------------|
| Internal reference voltage input channel ^{*2} | 1.42 | 1.48 | 1.54 | V | — |
| PCLKD (ADCLK) frequency ^{*3} | 1 | — | 2 | MHz | — |
| Sampling time ^{*4} | 5.0 | — | — | μs | — |

Note 1. The internal reference voltage cannot be selected for input channels when AVCC0 < 1.8 V.

Note 2. The 12-bit A/D internal reference voltage indicates the voltage when the internal reference voltage is input to the 12-bit A/D converter.

Note 3. When the internal reference voltage is selected as the high-potential reference voltage.

Note 4. When the internal reference voltage is converted.

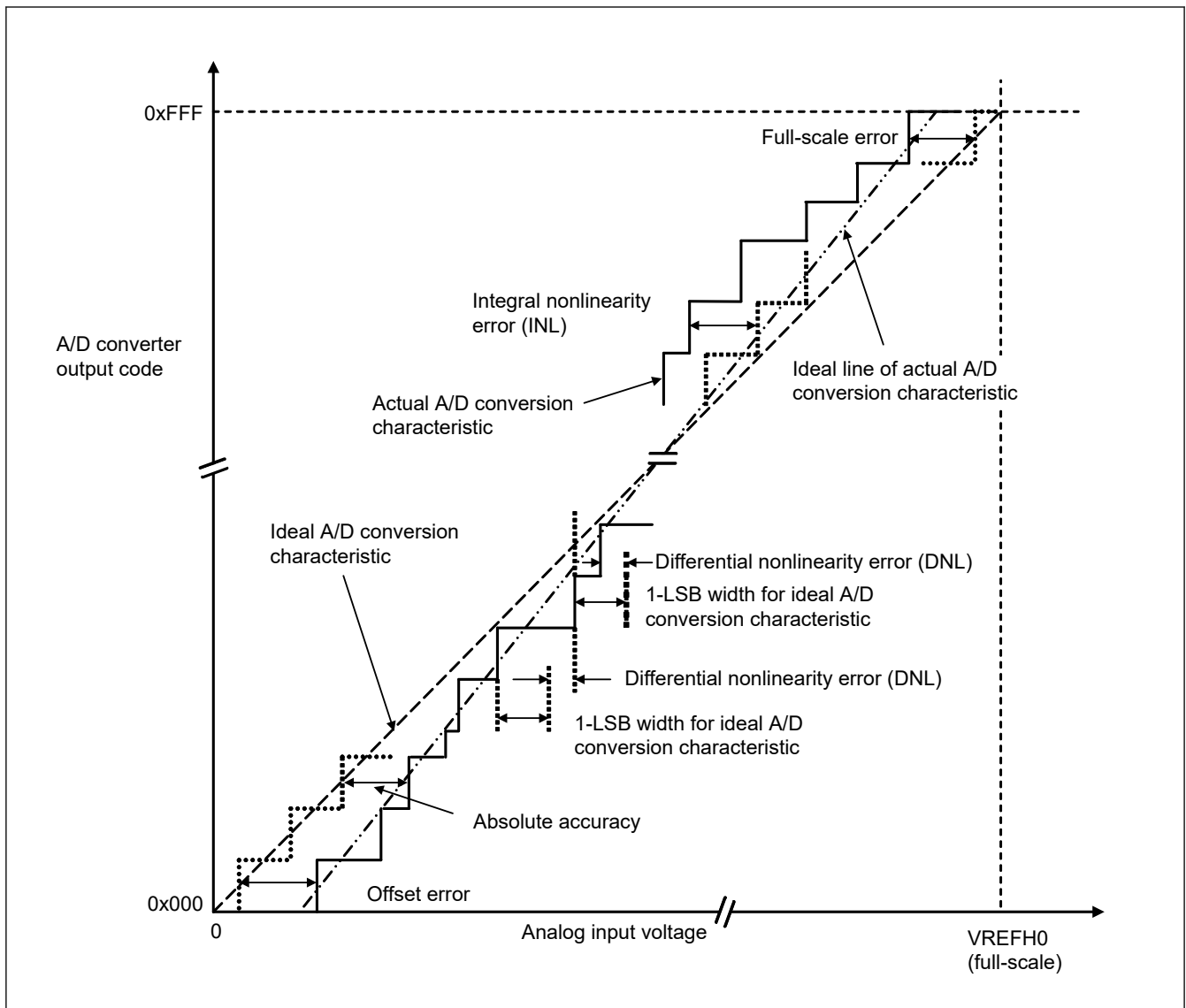

Figure 2.39 Illustration of 12-bit A/D converter characteristic terms

Absolute accuracy

Absolute accuracy is the difference between output code based on the theoretical A/D conversion characteristics, and the actual A/D conversion result. When measuring absolute accuracy, the voltage at the midpoint of the width of the analog input voltage (1-LSB width), which can meet the expectation of outputting an equal code based on the theoretical A/D conversion characteristics, is used as the analog input voltage. For example, if 12-bit resolution is used and the reference voltage $V_{REFH0} = 3.072$ V, then 1-LSB width becomes 0.75 mV, and 0 mV, 0.75 mV, and 1.5 mV are used as the analog input voltages. If analog input voltage is 6 mV, an absolute accuracy of ± 5 LSB means that the actual A/D conversion result is in the range of 0x003 to 0x00D, though an output code of 0x008 can be expected from the theoretical A/D conversion characteristics.

Integral nonlinearity error (INL)

Integral nonlinearity error is the maximum deviation between the ideal line when the measured offset and full-scale errors are zeroed, and the actual output code.

Differential nonlinearity error (DNL)

Differential nonlinearity error is the difference between 1-LSB width based on the ideal A/D conversion characteristics and the width of the actual output code.

Offset error

Offset error is the difference between the transition point of the ideal first output code and the actual first output code.

Full-scale error

Full-scale error is the difference between the transition point of the ideal last output code and the actual last output code.

2.5 DAC12 Characteristics

Table 2.44 12-bit D/A conversion characteristics

Conditions: VCC = AVCC0 = 1.8 to 5.5 V
Reference voltage = AVCC0 or AVSS0 selected

| Parameter | Min | Typ | Max | Unit | Test conditions |
|-------------------------------------|------|------|------------|------|-----------------|
| Resolution | — | — | 12 | bit | — |
| Resistive load | 30 | — | — | kΩ | — |
| Capacitive load | — | — | 50 | pF | — |
| Output voltage range | 0.35 | — | AVCC0-0.47 | V | — |
| DNL differential nonlinearity error | — | ±0.5 | ±2.0 | LSB | — |
| INL integral nonlinearity error | — | ±2.0 | ±8.0 | LSB | — |
| Offset error | — | — | ±30 | mV | — |
| Full-scale error | — | — | ±30 | mV | — |
| Output impedance | — | 5 | — | Ω | — |
| Conversion time | — | — | 30 | μs | — |

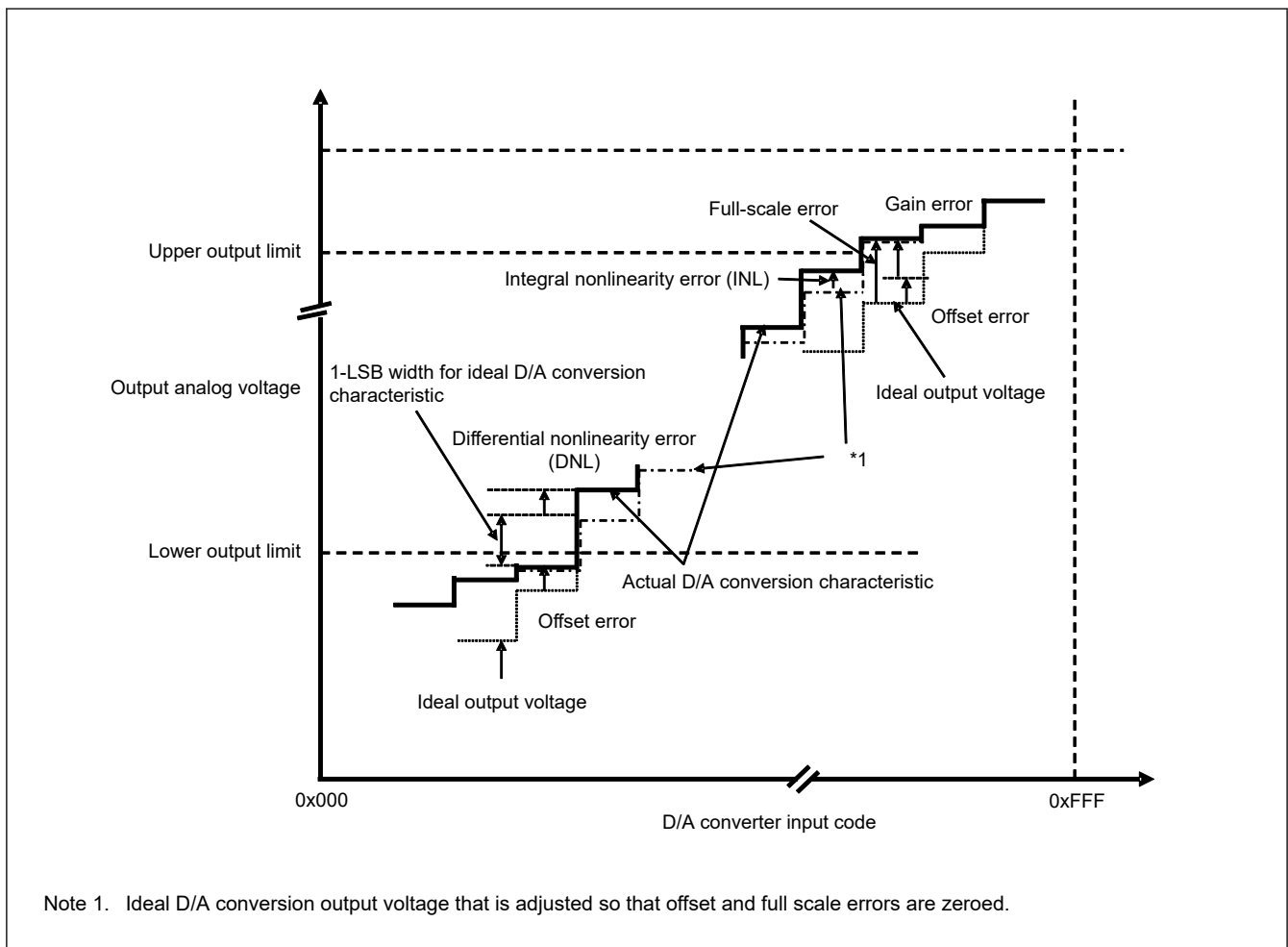

Figure 2.40 Illustration of D/A converter characteristic terms

Integral nonlinearity error (INL)

Integral nonlinearity error is the maximum deviation between the ideal output voltage based on the ideal conversion characteristic when the measured offset and full-scale errors are zeroed, and the actual output voltage.

Differential nonlinearity error (DNL)

Differential nonlinearity error is the difference between 1-LSB voltage width based on the ideal D/A conversion characteristics and the width of the actual output voltage.

Offset error

Offset error is the difference between the highest actual output voltage that falls below the lower output limit and the ideal output voltage based on the input code.

Full-scale error

Full-scale error is the difference between the lowest actual output voltage that exceeds the upper output limit and the ideal output voltage based on the input code.

2.6 TSN Characteristics

Table 2.45 TSN characteristics

Conditions: VCC = AVCC0 = 1.8 to 5.5 V

| Parameter | Symbol | Min | Typ | Max | Unit | Test conditions |
|-------------------------------|--------------------|-----|-------|-----|-------|-----------------|
| Relative accuracy | — | — | ± 1.5 | — | °C | 2.4 V or above |
| | | — | ± 2.0 | — | °C | Below 2.4 V |
| Temperature slope | — | — | -3.3 | — | mV/°C | — |
| Output voltage (at 25°C) | — | — | 1.05 | — | V | VCC = 3.3 V |
| Temperature sensor start time | t _{START} | — | — | 5 | μs | — |
| Sampling time | — | 5 | — | — | μs | — |

2.7 OSC Stop Detect Characteristics

Table 2.46 Oscillation stop detection circuit characteristics

| Parameter | Symbol | Min | Typ | Max | Unit | Test conditions |
|----------------|-----------------|-----|-----|-----|------|-----------------|
| Detection time | t _{dr} | — | — | 1 | ms | Figure 2.41 |

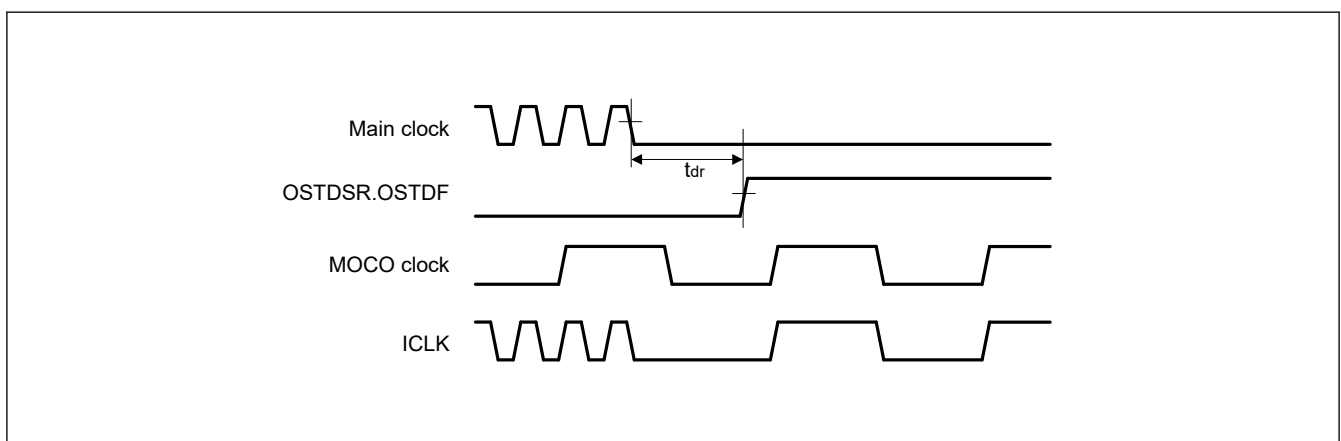

Figure 2.41 Oscillation stop detection timing

2.8 POR and LVD Characteristics

Table 2.47 Power-on reset circuit and voltage detection circuit characteristics (1) (1 of 2)

| Parameter | | | Symbol | Min | Typ | Max | Unit | Test Conditions |
|---------------------------|------------------------------------|------------------------|------------------------|------|------|------|------|--|
| Voltage detection level*1 | Power-on reset (POR) | When power supply rise | V _{POR} | 1.47 | 1.51 | 1.55 | V | Figure 2.42 |
| | | When power supply fall | V _{PDR} | 1.46 | 1.50 | 1.54 | | Figure 2.43 |
| | Voltage detection circuit (LVD0)*2 | When power supply rise | V _{det0_0} | 3.74 | 3.91 | 4.06 | V | Figure 2.44 At falling edge VCC |
| | | | When power supply fall | | 3.68 | 3.85 | | |
| | | When power supply rise | V _{det0_1} | 2.73 | 2.9 | 3.01 | | |
| | | | When power supply fall | | 2.68 | 2.85 | | |
| | | When power supply rise | V _{det0_2} | 2.44 | 2.59 | 2.70 | | |
| | | | When power supply fall | | 2.38 | 2.53 | | |
| | | When power supply rise | V _{det0_3} | 1.83 | 1.95 | 2.07 | | |
| | | | When power supply fall | | 1.78 | 1.90 | | |
| | | When power supply rise | V _{det0_4} | 1.66 | 1.75 | 1.88 | | |
| | | | When power supply fall | | 1.60 | 1.69 | | |
| Voltage detection level*1 | Voltage detection circuit (LVD1)*3 | When power supply rise | V _{det1_0} | 4.23 | 4.39 | 4.55 | V | Figure 2.45 At falling edge VCC |
| | | | When power supply fall | | 4.13 | 4.29 | | |
| | | When power supply rise | V _{det1_1} | 4.07 | 4.25 | 4.39 | | |
| | | | When power supply fall | | 3.98 | 4.16 | | |
| | | When power supply rise | V _{det1_2} | 3.97 | 4.14 | 4.29 | | |
| | | | When power supply fall | | 3.86 | 4.03 | | |
| | | When power supply rise | V _{det1_3} | 3.74 | 3.92 | 4.06 | | |
| | | | When power supply fall | | 3.68 | 3.86 | | |
| | | When power supply rise | V _{det1_4} | 3.05 | 3.17 | 3.29 | | |
| | | | When power supply fall | | 2.98 | 3.10 | | |
| | | When power supply rise | V _{det1_5} | 2.95 | 3.06 | 3.17 | | |
| | | | When power supply fall | | 2.89 | 3.00 | | |
| | | When power supply rise | V _{det1_6} | 2.86 | 2.97 | 3.08 | | |
| | | | When power supply fall | | 2.79 | 2.90 | | |
| | | When power supply rise | V _{det1_7} | 2.74 | 2.85 | 2.96 | | |
| | | | When power supply fall | | 2.68 | 2.79 | | |

Table 2.47 Power-on reset circuit and voltage detection circuit characteristics (1) (2 of 2)

| Parameter | | Symbol | Min | Typ | Max | Unit | Test Conditions | |
|---------------------------|------------------------------------|------------------------|---------------------|------|------|------|-----------------|------------------------------------|
| Voltage detection level*1 | Voltage detection circuit (LVD1)*3 | When power supply rise | V _{det1_8} | 2.63 | 2.75 | 2.85 | V | Figure 2.45 At falling edge VCC |
| | | When power supply fall | | 2.58 | 2.68 | 2.78 | | |
| | | When power supply rise | V _{det1_9} | 2.54 | 2.64 | 2.75 | | |
| | | When power supply fall | | 2.48 | 2.58 | 2.68 | | |
| | | When power supply rise | V _{det1_A} | 2.43 | 2.53 | 2.63 | | |
| | | When power supply fall | | 2.38 | 2.48 | 2.58 | | |
| | | When power supply rise | V _{det1_B} | 2.16 | 2.26 | 2.36 | | |
| | | When power supply fall | | 2.10 | 2.20 | 2.30 | | |
| | | When power supply rise | V _{det1_C} | 1.88 | 2 | 2.09 | | |
| | | When power supply fall | | 1.84 | 1.96 | 2.05 | | |
| | | When power supply rise | V _{det1_D} | 1.78 | 1.9 | 1.99 | | |
| | | When power supply fall | | 1.74 | 1.86 | 1.95 | | |
| | | When power supply rise | V _{det1_E} | 1.67 | 1.79 | 1.88 | | |
| | | When power supply fall | | 1.63 | 1.75 | 1.84 | | |
| | | When power supply rise | V _{det1_F} | 1.65 | 1.7 | 1.78 | | |
| | | When power supply fall | | 1.60 | 1.65 | 1.73 | | |
| Voltage detection level*1 | Voltage detection circuit (LVD2)*4 | When power supply rise | V _{det2_0} | 4.20 | 4.40 | 4.57 | V | Figure 2.46 At falling edge VCC |
| | | When power supply fall | | 4.11 | 4.31 | 4.48 | | |
| | | When power supply rise | V _{det2_1} | 4.05 | 4.25 | 4.42 | | |
| | | When power supply fall | | 3.97 | 4.17 | 4.34 | | |
| | | When power supply rise | V _{det2_2} | 3.91 | 4.11 | 4.28 | | |
| | | When power supply fall | | 3.83 | 4.03 | 4.20 | | |
| | | When power supply rise | V _{det2_3} | 3.71 | 3.91 | 4.08 | | |
| | | When power supply fall | | 3.64 | 3.84 | 4.01 | | |

Note 1. These characteristics apply when noise is not superimposed on the power supply. When a setting causes this voltage detection level to overlap with that of the voltage detection circuit, it cannot be specified whether LVD1 or LVD2 is used for voltage detection.

Note 2. # in the symbol V_{det0_#} denotes the value of the OFS1.VDSEL0[2:0] bits.

Note 3. # in the symbol V_{det1_#} denotes the value of the LVDLVLRLVD1LVL[4:0] bits.

Note 4. # in the symbol V_{det2_#} denotes the value of the LVDLVLRLVD2LVL[2:0] bits.

Table 2.48 Power-on reset circuit and voltage detection circuit characteristics (2) (1 of 2)

| Parameter | | Symbol | Min | Typ | Max | Unit | Test Conditions |
|--|-----------------|-----------------------|-----|-----|-----|------|-----------------------------------|
| Wait time after power-on reset cancellation | LVD0: enable | t _{POR} | — | 4.3 | — | ms | — |
| | LVD0: disable | t _{POR} | — | 3.7 | — | ms | — |
| Wait time after voltage monitor 0, 1, 2 reset cancellation | LVD0: enable*1 | t _{LVD0,1,2} | — | 1.4 | — | ms | — |
| | LVD0: disable*2 | t _{LVD1,2} | — | 0.7 | — | ms | — |
| Power-on reset response delay time*3 | | t _{det} | — | — | 500 | μs | Figure 2.42, Figure 2.43 |
| LVD0 response delay time*3 | | t _{det} | — | — | 500 | μs | Figure 2.44 |
| LVD1 response delay time*3 | | t _{det} | — | — | 350 | μs | Figure 2.45 |
| LVD2 response delay time*3 | | t _{det} | — | — | 600 | μs | Figure 2.46 |
| Minimum VCC down time | | t _{VOFF} | 500 | — | — | μs | Figure 2.42, VCC = 1.0 V or above |
| Power-on reset enable time | | t _{W (POR)} | 1 | — | — | ms | Figure 2.43, VCC = below 1.0 V |

Table 2.48 Power-on reset circuit and voltage detection circuit characteristics (2) (2 of 2)

| Parameter | Symbol | Min | Typ | Max | Unit | Test Conditions |
|---|-------------|-----|-----|------|---------|---|
| LVD1 operation stabilization time (after LVD1 is enabled) | $T_d (E-A)$ | — | — | 300 | μs | Figure 2.45 |
| LVD2 operation stabilization time (after LVD2 is enabled) | $T_d (E-A)$ | — | — | 1200 | μs | Figure 2.46 |
| Hysteresis width (POR) | V_{PORH} | — | 10 | — | mV | — |
| Hysteresis width (LVD0, LVD1 and LVD2) | V_{LVH} | — | 60 | — | mV | LVD0 selected |
| | | — | 110 | — | | V_{det1_0} to V_{det1_2} selected |
| | | — | 70 | — | | V_{det1_3} to V_{det1_9} selected |
| | | — | 60 | — | | V_{det1_A} to V_{det1_B} selected |
| | | — | 50 | — | | V_{det1_C} to V_{det1_F} selected |
| | | — | 90 | — | | LVD2 selected |

Note 1. When OFS1.LVDAS = 0.

Note 2. When OFS1.LVDAS = 1.

Note 3. The minimum VCC down time indicates the time when VCC is below the minimum value of voltage detection levels V_{POR} , V_{det0} , V_{det1} , and V_{det2} for the POR/LVD.

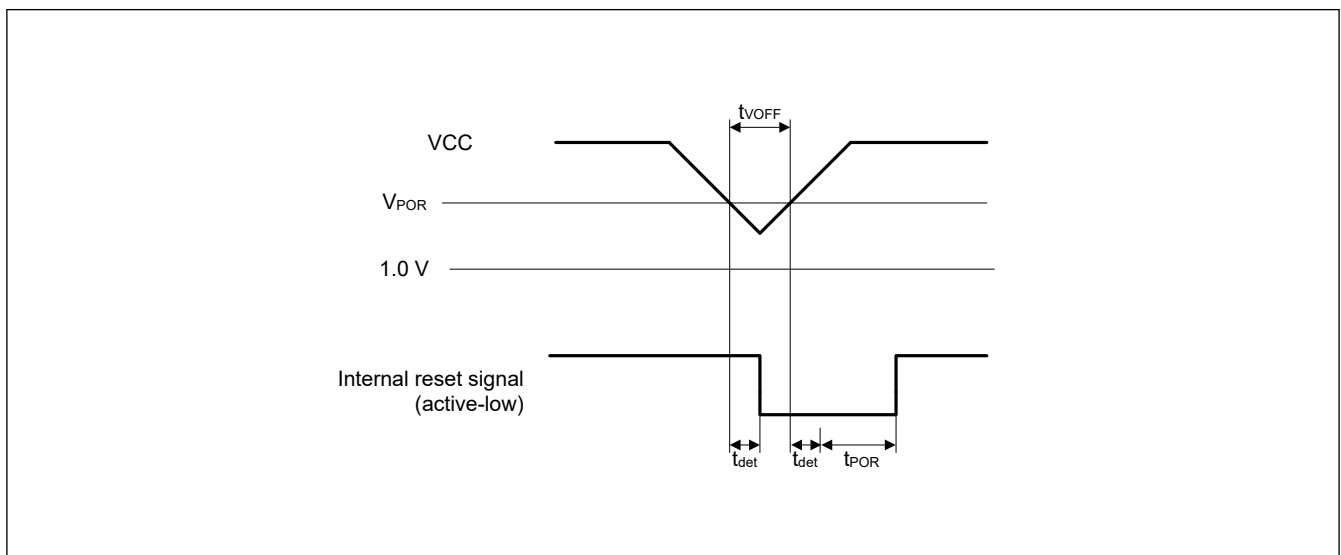

Figure 2.42 Voltage detection reset timing

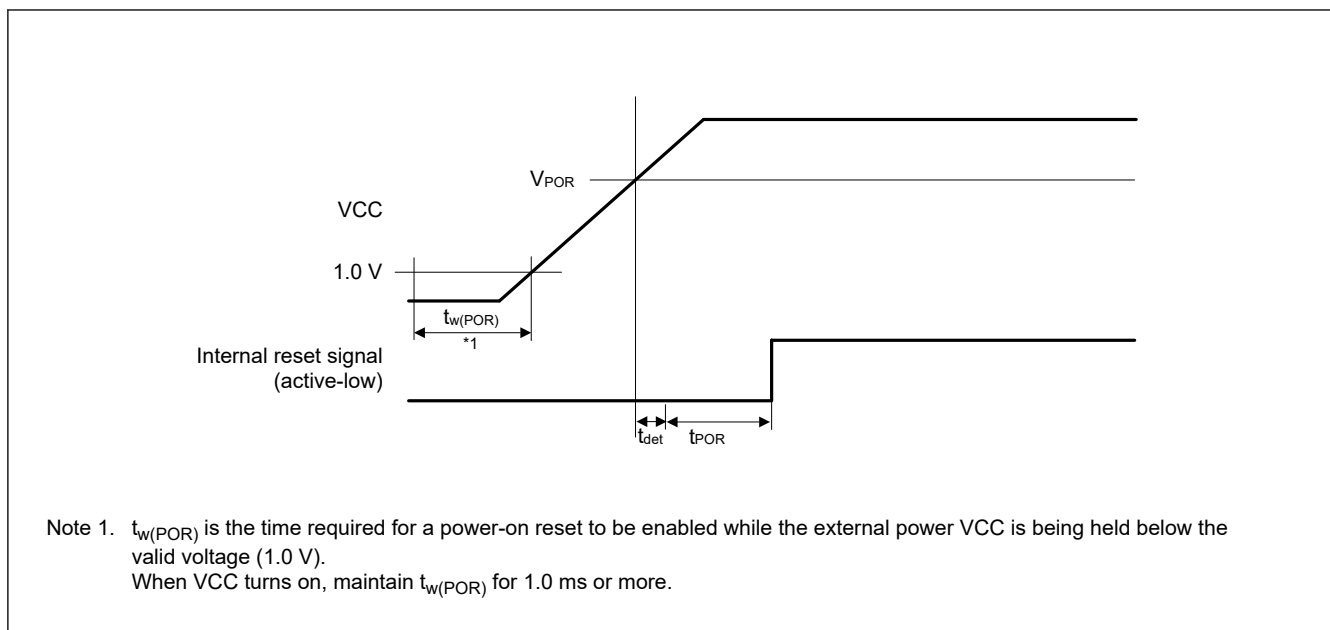

Figure 2.43 Power-on reset timing

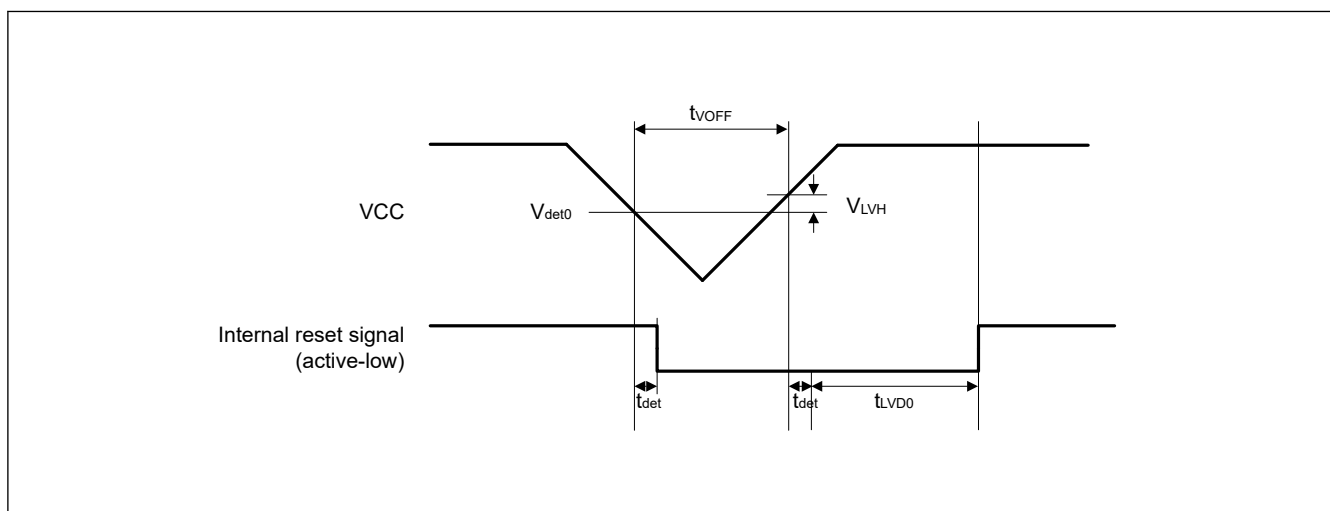

Figure 2.44 Voltage detection circuit timing (V_{det0})

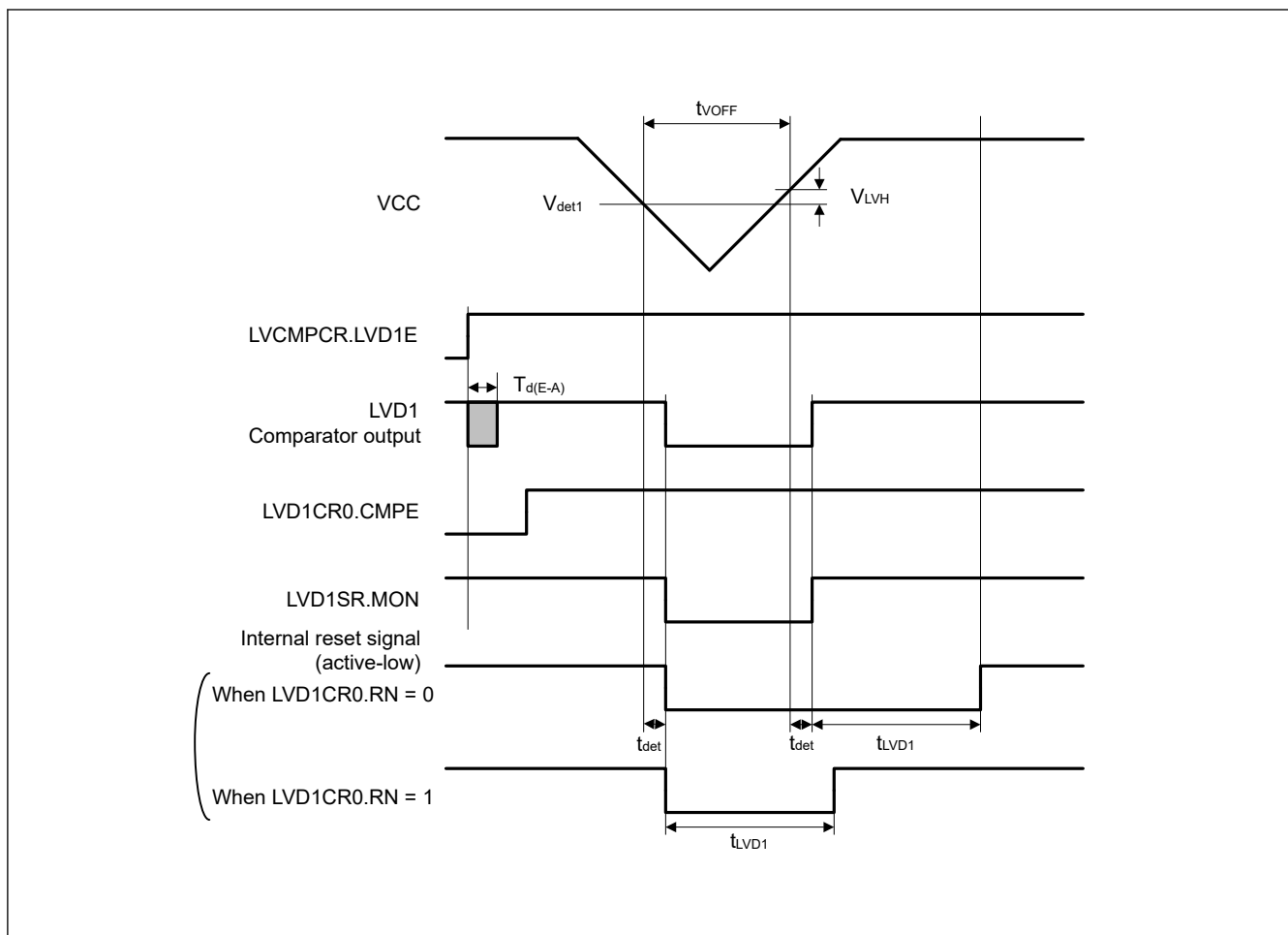

Figure 2.45 Voltage detection circuit timing (V_{det1})

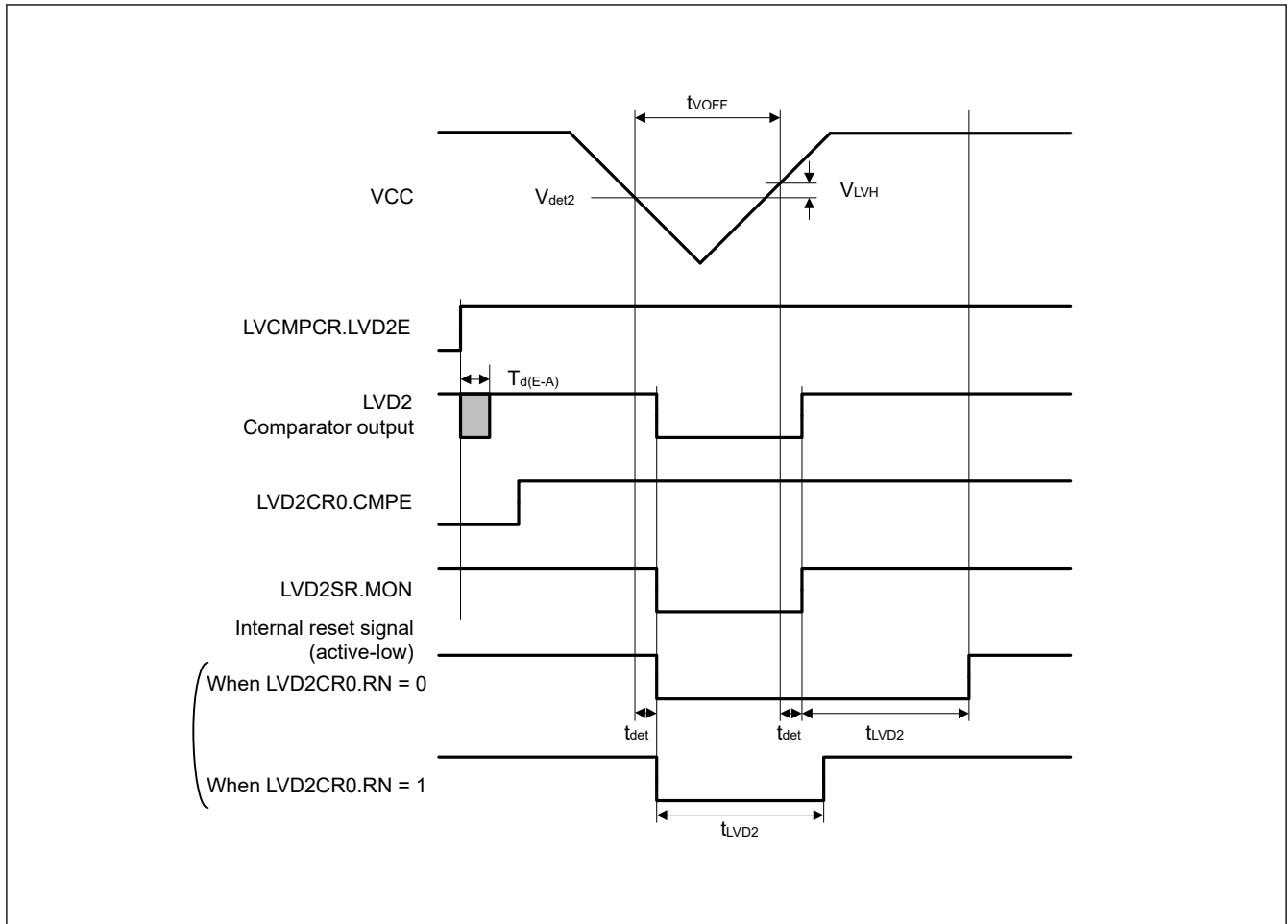

Figure 2.46 Voltage detection circuit timing (V_{det2})

2.9 CTSU Characteristics

Table 2.49 CTSU characteristics

Conditions: $VCC = AVCC0 = 1.8$ to 5.5 V

| Parameter | Symbol | Min | Typ | Max | Unit | Test conditions |
|---|-------------|-----|-----|-----|------|-----------------|
| External capacitance connected to TSCAP pin | C_{tscap} | 9 | 10 | 11 | nF | — |

2.10 Comparator Characteristics

Table 2.50 ACMLP characteristics (1 of 2)

Conditions: $VCC = AVCC0 = 1.6$ to 5.5 V, $VSS = AVSS0 = 0$ V

| Parameter | Symbol | Min | Typ | Max | Unit | Test conditions | |
|------------------------------|-----------------|-------|------|-----------|------|-----------------|---------------|
| Reference voltage range | V_{REF} | 0 | — | $VCC-1.4$ | V | — | |
| Input voltage range | V_I | 0 | — | VCC | V | — | |
| Internal reference voltage*1 | — | 1.34 | 1.44 | 1.54 | V | — | |
| Output delay time | High-speed mode | T_d | — | — | 1.2 | μs | $VCC = 3.0$ V |
| | Low-speed mode | | — | — | 9 | μs | |
| | Window mode | | — | — | 2 | μs | |
| Offset voltage | High-speed mode | — | — | 50 | mV | — | |
| | Low-speed mode | — | — | 40 | mV | — | |
| | Window mode | — | — | 60 | mV | — | |

Table 2.50 ACMPLP characteristics (2 of 2)

Conditions: VCC = AVCC0 = 1.6 to 5.5 V, VSS = AVSS0 = 0 V

| Parameter | Symbol | Min | Typ | Max | Unit | Test conditions | |
|--|------------------|------------------|------------|-----|------|-----------------|---|
| Internal reference voltage for window mode | V _{RFH} | — | 0.76 × VCC | — | V | — | |
| | V _{RFL} | — | 0.24 × VCC | — | V | — | |
| Operation stabilization wait time | High-speed mode | T _{cmp} | 100 | — | — | μs | — |
| | | | 200 | — | — | | |

Note 1. The internal reference voltage can be selected as ACMPLP reference voltage only when 2.94 V ≤ VCC ≤ 5.50 V.

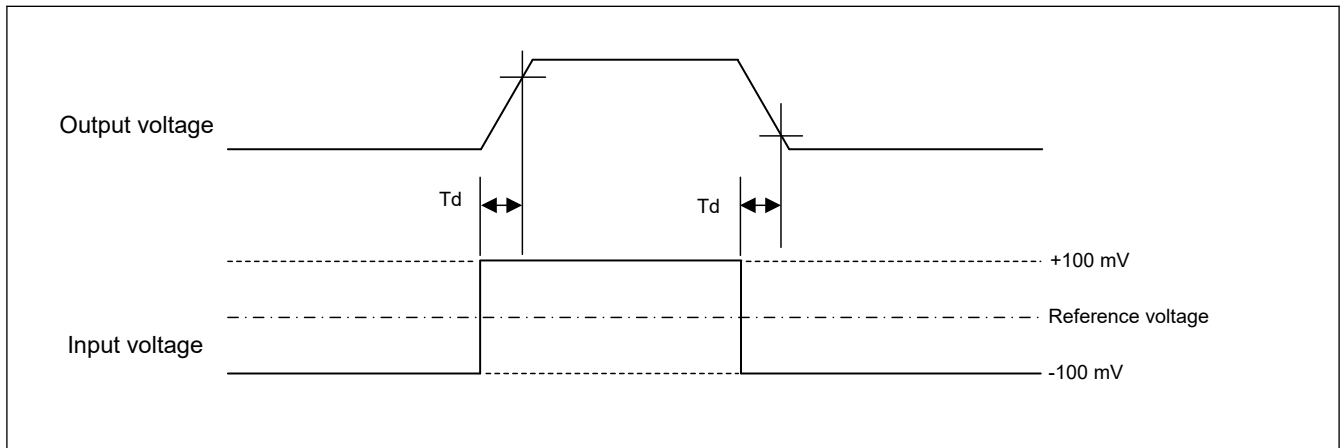

Figure 2.47 Output delay time

2.11 Flash Memory Characteristics

2.11.1 Code Flash Memory Characteristics

Table 2.51 Code flash characteristics (1)

| Parameter | Symbol | Min | Typ | Max | Unit | Conditions |
|-------------------------------|-----------------------------------|------------------|--------|-----|-------|---|
| Reprogramming/erasure cycle*1 | N _{PEC} | 1000 | — | — | Times | — |
| Data hold time | After 1000 times N _{PEC} | t _{DRP} | 20*2*3 | — | Year | T _a = +85°C T _a = +105°C |

Note 1. The reprogram/erase cycle is the number of erasures for each block. When the reprogram/erase cycle is n times (n = 1,000), erasing can be performed n times for each block. For instance, when 4-byte programming is performed 512 times for different addresses in 2-KB blocks, and then the entire block is erased, the reprogram/erase cycle is counted as one. However, programming the same address for several times as one erasure is not enabled (overwriting is prohibited).

Note 2. Characteristic when using the flash memory programmer and the self-programming library provided by Renesas Electronics.

Note 3. This result is target spec, may changed after reliability testing.

Table 2.52 Code flash characteristics (2) (1 of 2)

High-speed operating mode

Conditions: VCC = AVCC0 = 1.8 to 5.5 V

| Parameter | Symbol | ICLK = 1 MHz | | | ICLK = 48 MHz | | | Unit | |
|----------------------|------------------|-------------------|-----|------|---------------|-----|------|------|----|
| | | Min | Typ | Max | Min | Typ | Max | | |
| Programming time | 4-byte | t _{P4} | — | 86 | 732 | — | 34 | 321 | μs |
| Erasure time | 2-KB | t _{E2K} | — | 12.5 | 355 | — | 5.6 | 215 | ms |
| Blank check time | 4-byte | t _{BC4} | — | — | 46.5 | — | — | 8.3 | μs |
| | 2-KB | t _{BC2K} | — | — | 3681 | — | — | 240 | μs |
| Erase suspended time | t _{SED} | — | — | 22.3 | — | — | 10.5 | μs | |

Table 2.52 Code flash characteristics (2) (2 of 2)

High-speed operating mode

Conditions: VCC = AVCC0 = 1.8 to 5.5 V

| Parameter | Symbol | ICLK = 1 MHz | | | ICLK = 48 MHz | | | Unit |
|---|---------------------|--------------|------|------|---------------|------|------|------|
| | | Min | Typ | Max | Min | Typ | Max | |
| Access window information program Start-up area selection and security setting time | t _{AWSSAS} | — | 21.2 | 570 | — | 11.4 | 423 | ms |
| OCD/serial programmer ID setting time*1 | t _{OSIS} | — | 84.7 | 2280 | — | 45.3 | 1690 | ms |
| Flash memory mode transition wait time 1 | t _{DIS} | 2 | — | — | 2 | — | — | μs |
| Flash memory mode transition wait time 2 | t _{MS} | 15 | — | — | 15 | — | — | μs |

Note: Does not include the time until each operation of the flash memory is started after instructions are executed by software.

Note: The lower-limit frequency of ICLK is 1 MHz during programming or erasing the flash memory. When using ICLK at below 4 MHz, the frequency can be set to 1 MHz, 2 MHz, or 3 MHz. A non-integer frequency such as 1.5 MHz cannot be set.

Note: The frequency accuracy of ICLK must be ± 1.0% during programming or erasing the flash memory. Confirm the frequency accuracy of the clock source.

Note 1. Total time of four commands.

Table 2.53 Code flash characteristics (3)

Middle-speed operating mode

Conditions: VCC = AVCC0 = 1.6 to 5.5 V

| Parameter | Symbol | ICLK = 1 MHz | | | ICLK = 8 MHz*2 | | | Unit | |
|---|---------------------|-------------------|------|------|----------------|------|------|------|----|
| | | Min | Typ | Max | Min | Typ | Max | | |
| Programming time | 4-byte | t _{P4} | — | 86 | 732 | — | 39 | 356 | μs |
| Erase time | 2-KB | t _{E2K} | — | 12.5 | 355 | — | 6.2 | 227 | ms |
| Blank check time | 4-byte | t _{BC4} | — | — | 46.5 | — | — | 11.3 | μs |
| | 2-KB | t _{BC2K} | — | — | 3681 | — | — | 534 | μs |
| Erase suspended time | t _{SED} | — | — | 22.3 | — | — | 11.7 | μs | |
| Access window information program Start-up area selection and security setting time | t _{AWSSAS} | — | 21.2 | 570 | — | 12.2 | 435 | ms | |
| OCD/serial programmer ID setting time*1 | t _{OSIS} | — | 84.7 | 2280 | — | 48.7 | 1740 | ms | |
| Flash memory mode transition wait time 1 | t _{DIS} | 2 | — | — | 2 | — | — | μs | |
| Flash memory mode transition wait time 2 | t _{MS} | 15 | — | — | 15 | — | — | μs | |

Note: Does not include the time until each operation of the flash memory is started after instructions are executed by software.

Note: The lower-limit frequency of ICLK is 1 MHz during programming or erasing the flash memory. When using ICLK at below 4 MHz, the frequency can be set to 1 MHz, 2 MHz, or 3 MHz. A non-integer frequency such as 1.5 MHz cannot be set.

Note: The frequency accuracy of ICLK must be ± 1.0% during programming or erasing the flash memory. Confirm the frequency accuracy of the clock source.

Note 1. Total time of four commands.

Note 2. When 1.8 V ≤ VCC = AVCC0 ≤ 5.5 V

Table 2.54 Code flash characteristics (4) (1 of 2)

Low-speed operating mode

Conditions: VCC = AVCC0 = 1.6 to 5.5 V

| Parameter | Symbol | ICLK = 1 MHz | | | ICLK = 2 MHz | | | Unit | |
|------------------|--------|------------------|-----|------|--------------|-----|-----|------|----|
| | | Min | Typ | Max | Min | Typ | Max | | |
| Programming time | 4-byte | t _{P4} | — | 86 | 732 | — | 57 | 502 | μs |
| Erase time | 2-KB | t _{E2K} | — | 12.5 | 355 | — | 8.8 | 280 | ms |

Table 2.54 Code flash characteristics (4) (2 of 2)

Low-speed operating mode

Conditions: VCC = AVCC0 = 1.6 to 5.5 V

| Parameter | | Symbol | ICLK = 1 MHz | | | ICLK = 2 MHz | | | Unit |
|---|--------|---------------------|--------------|------|------|--------------|------|------|------|
| | | | Min | Typ | Max | Min | Typ | Max | |
| Blank check time | 4-byte | t _{BC4} | — | — | 46.5 | — | — | 23.3 | μs |
| | 2-KB | t _{BC2K} | — | — | 3681 | — | — | 1841 | μs |
| Erase suspended time | | t _{SED} | — | — | 22.3 | — | — | 16.2 | μs |
| Access window information program Start-up area selection and security setting time | | t _{AWSSAS} | — | 21.2 | 570 | — | 15.9 | 491 | ms |
| OCD/serial programmer ID setting time*1 | | t _{OSIS} | — | 84.7 | 2280 | — | 63.5 | 1964 | ms |
| Flash memory mode transition wait time 1 | | t _{DIS} | 2 | — | — | 2 | — | — | μs |
| Flash memory mode transition wait time 2 | | t _{MS} | 15 | — | — | 15 | — | — | μs |

Note: Does not include the time until each operation of the flash memory is started after instructions are executed by software.

Note: The lower-limit frequency of ICLK is 1 MHz during programming or erasing the flash memory. When using ICLK at below 4 MHz, the frequency can be set to 1 MHz or 2 MHz. A non-integer frequency such as 1.5 MHz cannot be set.

Note: The frequency accuracy of ICLK must be ± 1.0% during programming or erasing the flash memory. Confirm the frequency accuracy of the clock source.

Note 1. Total time of four commands.

2.11.2 Data Flash Memory Characteristics

Table 2.55 Data flash characteristics (1)

| Parameter | | Symbol | Min | Typ | Max | Unit | Conditions |
|-------------------------------|--|-------------------|---------|---------|-----|-------|---------------------------|
| Reprogramming/erasure cycle*1 | | N _{DPEC} | 100000 | 1000000 | — | Times | — |
| Data hold time | After 10000 times of N _{DPEC} | t _{DDRP} | 20*2 *3 | — | — | Year | Ta = +85°C Ta = +105°C |
| | After 100000 times of N _{DPEC} | | 5*2 *3 | — | — | Year | |
| | After 1000000 times of N _{DPEC} | | — | 1*2 *3 | — | — | Year |

Note 1. The reprogram/erase cycle is the number of erasure for each block. When the reprogram/erase cycle is n times (n = 100,000), erasing can be performed n times for each block. For instance, when 1-byte programming is performed 1,024 times for different addresses in 1-KB blocks, and then the entire block is erased, the reprogram/erase cycle is counted as one. However, programming the same address for several times as one erasure is not enabled. (overwriting is prohibited.)

Note 2. Characteristics when using the flash memory programmer and the self-programming library provided by Renesas Electronics.

Note 3. These results are target spec, may changed after reliability testing.

Table 2.56 Data flash characteristics (2)

High-speed operating mode

Conditions: VCC = AVCC0 = 1.8 to 5.5 V

| Parameter | | Symbol | ICLK = 4 MHz | | | ICLK = 48 MHz | | | Unit |
|-------------------------------|--------|--------------------|--------------|-----|------|---------------|-----|------|------|
| | | | Min | Typ | Max | Min | Typ | Max | |
| Programming time | 1-byte | t _{DP1} | — | 45 | 404 | — | 34 | 321 | μs |
| Erasure time | 1-KB | t _{DE1K} | — | 8.8 | 280 | — | 6.1 | 224 | ms |
| Blank check time | 1-byte | t _{DBC1} | — | — | 15.2 | — | — | 8.3 | μs |
| | 1-KB | t _{DBC1K} | — | — | 1832 | — | — | 466 | μs |
| Suspended time during erasing | | t _{DSED} | — | — | 13.2 | — | — | 10.5 | μs |
| Data flash STOP recovery time | | t _{DSTOP} | 250 | — | — | 250 | — | — | ns |

Note: Does not include the time until each operation of the flash memory is started after instructions are executed by software.

Note: The lower-limit frequency of ICLK is 1 MHz during programming or erasing the flash memory. When using ICLK at below 4 MHz, the frequency can be set to 1 MHz, 2 MHz, or 3 MHz. A non-integer frequency such as 1.5 MHz cannot be set.

Note: The frequency accuracy of ICLK must be $\pm 1.0\%$ during programming or erasing the flash memory. Confirm the frequency accuracy of the clock source.

Table 2.57 Data flash characteristics (3)

Middle-speed operating mode

Conditions: VCC = AVCC0 = 1.6 to 5.5 V

| Parameter | | Symbol | ICLK = 4 MHz | | | ICLK = 8 MHz ^{*1} | | | Unit |
|-------------------------------|--------|--------------------|--------------|-----|------|----------------------------|-----|------|------|
| | | | Min | Typ | Max | Min | Typ | Max | |
| Programming time | 1-byte | t _{DP1} | — | 45 | 404 | — | 39 | 356 | μs |
| Erasure time | 1-KB | t _{DE1K} | — | 8.8 | 280 | — | 7.3 | 248 | ms |
| Blank check time | 1-byte | t _{DBC1} | — | — | 15.2 | — | — | 11.3 | μs |
| | 1-KB | t _{DBC1K} | — | — | 1.84 | — | — | 1.06 | ms |
| Suspended time during erasing | | t _{DSED} | — | — | 13.2 | — | — | 11.7 | μs |
| Data flash STOP recovery time | | t _{DSTOP} | 250 | — | — | 250 | — | — | ns |

Note: Does not include the time until each operation of the flash memory is started after instructions are executed by software.

Note: The lower-limit frequency of ICLK is 1 MHz during programming or erasing the flash memory. When using ICLK at below 4 MHz, the frequency can be set to 1 MHz, 2 MHz, or 3 MHz. A non-integer frequency such as 1.5 MHz cannot be set.

Note: The frequency accuracy of ICLK must be $\pm 1.0\%$ during programming or erasing the flash memory. Confirm the frequency accuracy of the clock source.

Note 1. When $1.8\text{ V} \leq \text{VCC} = \text{AVCC0} \leq 5.5\text{ V}$

Table 2.58 Data flash characteristics (4)

Low-speed operating mode

Conditions: VCC = AVCC0 = 1.6 to 5.5 V

| Parameter | | Symbol | ICLK = 1 MHz | | | ICLK = 2 MHz | | | Unit |
|-------------------------------|--------|--------------------|--------------|------|------|--------------|------|------|------|
| | | | Min | Typ | Max | Min | Typ | Max | |
| Programming time | 1-byte | t _{DP1} | — | 86 | 732 | — | 57 | 502 | μs |
| Erasure time | 1-KB | t _{DE1K} | — | 19.7 | 504 | — | 12.4 | 354 | ms |
| Blank check time | 1-byte | t _{DBC1} | — | — | 46.5 | — | — | 23.3 | μs |
| | 1-KB | t _{DBC1K} | — | — | 7.3 | — | — | 3.66 | ms |
| Suspended time during erasing | | t _{DSED} | — | — | 22.3 | — | — | 16.2 | μs |
| Data flash STOP recovery time | | t _{DSTOP} | 250 | — | — | 250 | — | — | ns |

Note: Does not include the time until each operation of the flash memory is started after instructions are executed by software.

Note: The lower-limit frequency of ICLK is 1 MHz during programming or erasing the flash memory. When using ICLK at below 2 MHz, the frequency can be set to 1 MHz or 2 MHz. A non-integer frequency such as 1.5 MHz cannot be set.

Note: The frequency accuracy of ICLK must be $\pm 1.0\%$ during programming or erasing the flash memory. Confirm the frequency accuracy of the clock source.

2.11.3 Serial Wire Debug (SWD)

Table 2.59 SWD characteristics (1)

Conditions: VCC = AVCC0 = 2.4 to 5.5 V

| Parameter | Symbol | Min | Typ | Max | Unit | Test conditions |
|------------------------------|----------------------|-----|-----|-----|------|-----------------|
| SWCLK clock cycle time | t _{SWCKcyc} | 80 | — | — | ns | Figure 2.48 |
| SWCLK clock high pulse width | t _{SWCKH} | 35 | — | — | ns | |
| SWCLK clock low pulse width | t _{SWCKL} | 35 | — | — | ns | |
| SWCLK clock rise time | t _{SWCKr} | — | — | 5 | ns | |
| SWCLK clock fall time | t _{SWCKf} | — | — | 5 | ns | |
| SWDIO setup time | t _{SWDS} | 16 | — | — | ns | Figure 2.49 |
| SWDIO hold time | t _{SWDH} | 16 | — | — | ns | |
| SWDIO data delay time | t _{SWDD} | 2 | — | 70 | ns | |

Table 2.60 SWD characteristics (2)

Conditions: VCC = AVCC0 = 1.6 to 2.4 V

| Parameter | Symbol | Min | Typ | Max | Unit | Test conditions |
|------------------------------|----------------|-----|-----|-----|------|-----------------|
| SWCLK clock cycle time | $t_{SWCLKcyc}$ | 250 | — | — | ns | Figure 2.48 |
| SWCLK clock high pulse width | t_{SWCKH} | 120 | — | — | ns | |
| SWCLK clock low pulse width | t_{SWCKL} | 120 | — | — | ns | |
| SWCLK clock rise time | t_{SWCKr} | — | — | 5 | ns | |
| SWCLK clock fall time | t_{SWCKf} | — | — | 5 | ns | |
| SWDIO setup time | t_{SWDS} | 50 | — | — | ns | Figure 2.49 |
| SWDIO hold time | t_{SWDH} | 50 | — | — | ns | |
| SWDIO data delay time | t_{SWDD} | 2 | — | 170 | ns | |

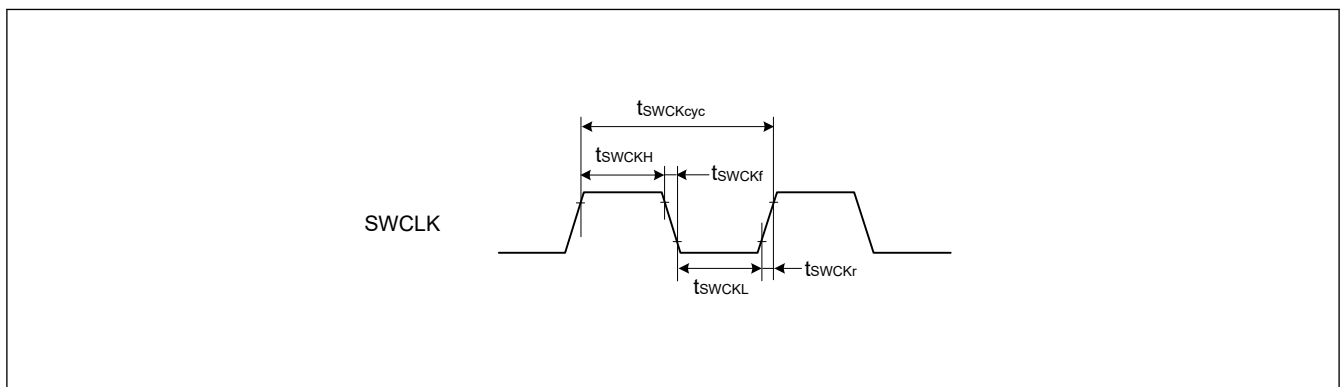

Figure 2.48 SWD SWCLK timing

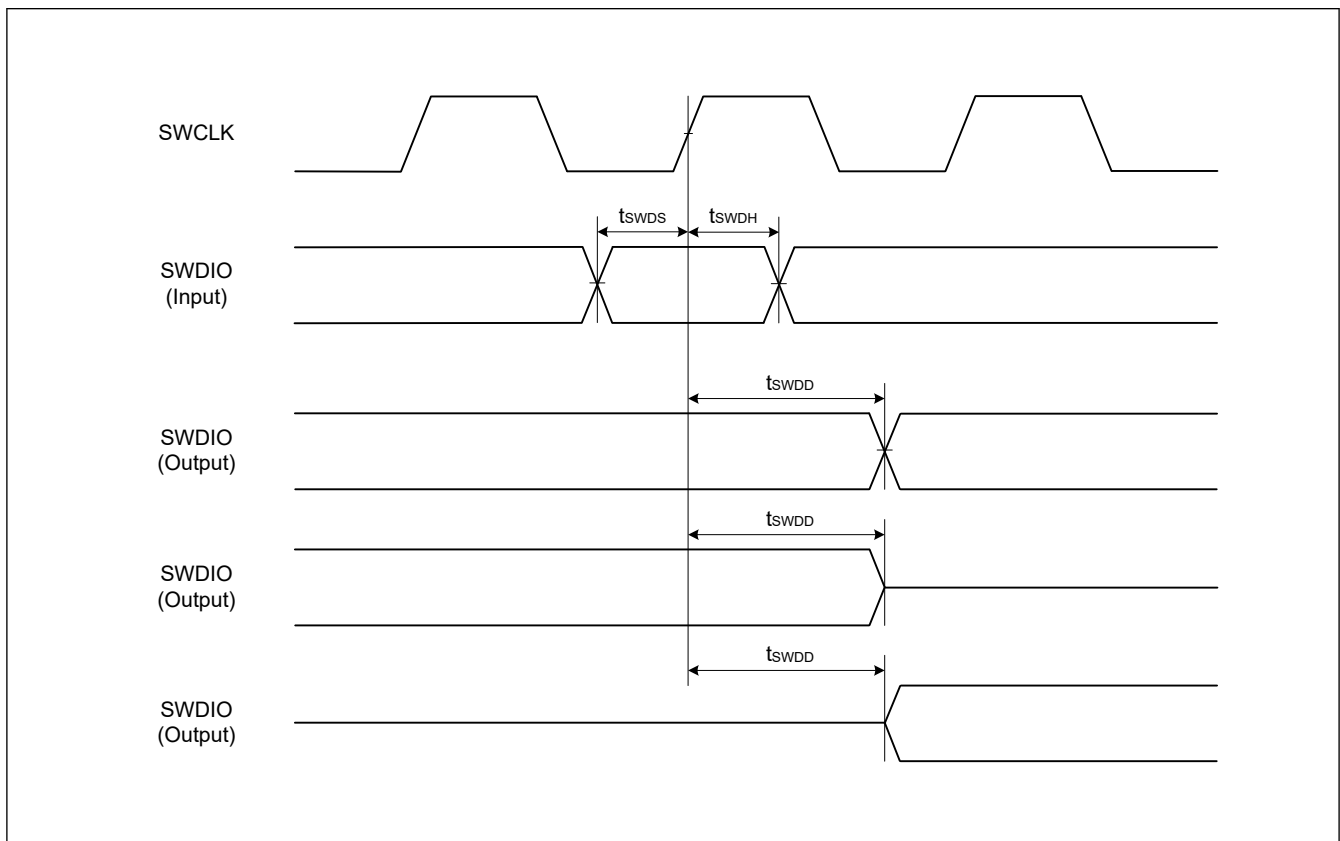

Figure 2.49 SWD input/output timing

2.12 DCDC Characteristics

Table 2.61 DCDC characteristics

Conditions: VCC = AVCC0 = VCC_DCDC = 2.4 to 5.5 V

| Parameter | Symbol | Min | Typ | Max | Unit | Test conditions |
|------------------------------------|--------|------|------|------|------|--|
| DCDC output Voltage | — | 1.42 | 1.50 | 1.58 | V | — |
| Power switching stabilization time | — | — | — | 22 | μs | Switch from LDO power to DCDC power |
| | — | — | — | 60 | μs | Switch from DCDC power to LDO power |
| | — | — | — | 60 | μs | Switch from DCDC power to LDO power in the LC boost mode |

Appendix 1. Port States in each Processing Mode

Table 1.1 Port states in each processing mode (1 of 4)

| Port name | Reset | Software Standby Mode |
|--|---------|---|
| P000/AN000/TS21/IRQ6 | Hi-Z | Keep-O ^{*1} |
| P001/AN001/TS22/IRQ7 | Hi-Z | Keep-O ^{*1} |
| P002/AN002/TS23/IRQ2 | Hi-Z | Keep-O ^{*1} |
| P003/AN003/TS24 | Hi-Z | Keep-O |
| P004/AN004/TS25/IRQ3 | Hi-Z | Keep-O ^{*1} |
| P005/AN011 | Hi-Z | Keep-O |
| P006/AN012 | Hi-Z | Keep-O |
| P007/AN013 | Hi-Z | Keep-O |
| P008/AN014 | Hi-Z | Keep-O |
| P010/AN005/TS30-CFC | Hi-Z | Keep-O |
| P011/AN006/TS31-CFC | Hi-Z | Keep-O |
| P012/AN007/TS32-CFC | Hi-Z | Keep-O |
| P013/AN008/TS33-CFC | Hi-Z | Keep-O |
| P014/AN009/DA0 | Hi-Z | [DA0 output (DACE0 = 1)] DA0 output retained [Other than the above (DACE0 = 0)] Keep-O |
| P015/AN010/TS28-CFC/IRQ7_A | Hi-Z | Keep-O ^{*1} |
| P100/CMPIN0/TS26-CFC/AGTIO0_A/GTETRGA_A/GTIOC5B_A/RXD0_A/ MISO0_A/SCL0_A/SCK1_A/SCL1_B/MISOA_A/KRM00/IRQ2_A | Hi-Z | [AGTIO0_A output selected] AGTIO0_A output ^{*2} [Other than the above] Keep-O ^{*1} |
| P101/CMPREF0/TS16-CFC/AGTEE0/GTETRGA_A/GTIOC5A_A/TXD0_A/ MOSI0_A/SDA0_A/CTS1_RTS1_A/SDA1_B/MOSIA_A/KRM01/IRQ1_A | Hi-Z | Keep-O ^{*1} |
| P102/CMPIN1/ADTRG0_A/TS15-CFC/AGTO0/GTOWLO_A/GTIOC2B_A/ CRX0_C/SCK0_A/TXD2_D/MOSI2_D/SDA2_D/RSPCKA_A/KRM02 | Hi-Z | [AGTO0 selected] AGTO0 output ^{*2} [Other than the above] Keep-O ^{*1} |
| P103/CMPREF1/TS14-CFC/GTOWUP_A/GTIOC2A_A/CTX0_C/ CTS0_RTS0_A/SSLA0_A/KRM03 | Hi-Z | Keep-O ^{*1} |
| P104/TS13-CFC/GTETRGA_B/GTIOC1B_C/RXD0_C/MISO0_C/SCL0_C/ SSLA1_A/KRM04/IRQ1_B | Hi-Z | Keep-O ^{*1} |
| P105/TS34-CFC/GTETRGA_C/GTIOC1A_C/SSLA2_A/KRM05/IRQ0_B | Hi-Z | Keep-O ^{*1} |
| P106/GTIOC8B_A/SSLA3_A/KRM06 | Hi-Z | Keep-O ^{*1} |
| P107/GTIOC8A_A/KRM07 | Hi-Z | Keep-O ^{*1} |
| P108/SWDIO/GTOULO_C/GTIOC0B_A/CTS9_RTS9_B/SSLB0_B | Pull-up | Keep-O |
| P109/TS10-CFC/GTOVUP_A/GTIOC1A_A/CTX0_A/SCK1_E/TXD9_B/ MOSI9_B/SDA9_B/MOSIB_B/CLKOUT_B | Hi-Z | [CLKOUT selected] CLKOUT output [Other than the above] Keep-O |
| P110/TS11-CFC/GTOVLO_A/GTIOC1B_A/CRX0_A/CTS2_RTS2_B/RXD9_B/ MISO9_B/SCL9_B/MISOB_B/IRQ3_A/VCOUT | Hi-Z | [ACMPLP selected] VCOUT output [Other than the above] Keep-O ^{*1} |

Table 1.1 Port states in each processing mode (2 of 4)

| Port name | Reset | Software Standby Mode |
|--|---------|--|
| P111/TS12-CFC/AGTOA0/GTIOC3A_A/SCK2_B/SCK9_B/RSPCKB_B/IRQ4_A | Hi-Z | [AGTOA0 selected] AGTOA0 output* ² [Other than the above] Keep-O* ¹ |
| P112/TSCAP_C/AGTOB0/GTIOC3B_A/TXD2_B/MOSI2_B/SDA2_B/SCK1_D/SSLB0_C | Hi-Z | [AGTOB0 selected] AGTOB0 output* ² [Other than the above] Keep-O |
| P113/TS27-CFC/GTIOC2A_C | Hi-Z | Keep-O |
| P114/TS29-CFC/GTIOC2B_C | Hi-Z | Keep-O |
| P115/TS35-CFC/GTIOC4A_C | Hi-Z | Keep-O |
| P200/NMI | Hi-Z | Hi-Z |
| P201/MD | Pull-up | Keep-O |
| P202/SCK2_A/RXD9_A/MISO9_A/SCL9_A/MISOB_A | Hi-Z | Keep-O |
| P203/CTS2_RTS2_A/TXD9_A/MOSI9_A/SDA9_A/MOSIB_A | Hi-Z | Keep-O |
| P204/CACREF_A/TS0/AGTIO1_A/GTIW_A/GTIOC4B_B/SCK0_D/SCK9_A/SCL0_B/RSPCKB_A | Hi-Z | [AGTIO1_A output selected] AGTIO1_A output* ² [Other than the above] Keep-O* ¹ |
| P205/AGTO1/GTIV_A/GTIOC4A_B/TXD0_D/MOSI0_D/SDA0_D/CTS9_RTS9_A/SCL1_A/SSLB0_A/IRQ1/CLKOUT_A | Hi-Z | [AGTO1 selected] AGTO1 output* ² [CLKOUT selected] CLKOUT output [Other than the above] Keep-O* ¹ |
| P206/GTIU_A/RXD0_D/MISO0_D/SCL0_D/SDA1_A/SSLB1_A/IRQ0 | Hi-Z | Keep-O* ¹ |
| P207 | Hi-Z | Keep-O |
| P208/AGTOB0_A | Hi-Z | [AGTOB0_A selected] AGTOB0_A output* ² [Other than the above] Keep-O |
| P212/EXTAL /AGTEE1/GTETRGB_D/GTIOC0B_D/RXD1_A/MISO1_A/SCL1_A/IRQ3_B | Hi-Z | Keep-O* ¹ |
| P213/XTAL /GTETRGA_D/GTIOC0A_D/TXD1_A/MOSI1_A/SDA1_A/IRQ2_B | Hi-Z | Keep-O* ¹ |
| P214/XCOUT, P215/XCIN | Hi-Z | [Sub-clock Oscillator selected] Sub-clock Oscillator is operating [Other than the above] Hi-Z |
| P300/SWCLK/GTOUUP_C/GTIOC0A_A/SSLB1_B | Pull-up | Keep-O |
| P301/TS9-CFC/AGTIO0_D/GTOULO_A/GTIOC4B_A/RXD2_A/MISO2_A/SCL2_A/CTS9_RTS9_D/SSLB2_B/IRQ6_A | Hi-Z | [AGTIO0_D output selected] AGTIO0_D output* ² [Other than the above] Keep-O* ¹ |
| P302/TS8-CFC/GTOUUP_A/GTIOC4A_A/TXD2_A/MOSI2_A/SDA2_A/SSLB3_B/IRQ5_A | Hi-Z | Keep-O* ¹ |
| P303/TS2-CFC/GTIOC7B_A | Hi-Z | Keep-O |
| P304/GTIOC7A_A | Hi-Z | Keep-O |
| P305, P306, P307 | Hi-Z | Keep-O |

Table 1.1 Port states in each processing mode (3 of 4)

| Port name | Reset | Software Standby Mode |
|---|-------|---|
| P400/CACREF_C/AGTIO1_C/GTIOC6A_A/SCK0_B/SCK1_B/SCL0_A/IRQ0_A | Hi-Z | [AGTIO1_C output selected] AGTIO1_C output* ² [Other than the above] Keep-O* ¹ |
| P401/GTETRGA_B/GTIOC6B_A/CTX0_B/CTS0_RTS0_B/TXD1_B/MOSI1_B/SDA1_B/SDA0_A/IRQ5 | Hi-Z | Keep-O* ¹ |
| P402/TS18/AGTIO0_E/AGTIO1_D/CRX0_B/RXD1_B/MISO1_B/SCL1_B/IRQ4 | Hi-Z | [AGTIO0_E, AGTIO1_D output selected] AGTIO0_E, AGTIO1_D output* ² [Other than the above] Keep-O* ¹ |
| P403/TS17/AGTIO0_F/AGTIO1_E/GTIOC3A_B/CTS1_RTS1_B | Hi-Z | [AGTIO0_F, AGTIO1_E output selected] AGTIO0_F, AGTIO1_E output* ² [Other than the above] Keep-O* ¹ |
| P404/GTIOC3B_B, P405/GTIOC1A_B, P406/GTIOC1B_B | Hi-Z | Keep-O |
| P407/ADTRG0_B/AGTIO0_C/RTCOUNT/CTS0_RTS0_D/SDA0_B/SSLB3_A | Hi-Z | [AGTIO0_C output selected] AGTIO0_C output* ² [RTCOUNT selected] RTCOUNT output [Other than the above] Keep-O* ¹ |
| P408/TS4/GTOWLO_B/GTIOC5B_B/CTS1_RTS1_D/RXD3_A/MISO3_A/SCL3_A/SCL0_C/IRQ7_B | Hi-Z | Keep-O* ¹ |
| P409/TS5/GTOWUP_B/GTIOC5A_B/TXD3_A/MOSI3_A/SDA3_A/IRQ6_B | Hi-Z | Keep-O* ¹ |
| P410/TS6/AGTOB1/GTOVLO_B/GTIOC9B_A/RXD0_B/MISO0_B/SCL0_B/SCK3_A/MISOA_B/IRQ5_B | Hi-Z | [AGTOB1 selected] AGTOB1 output* ² [Other than the above] Keep-O* ¹ |
| P411/TS7/AGTOA1/GTOVUP_B/GTIOC9A_A/TXD0_B/MOSI0_B/SDA0_B/CTS3_RTS3_A/MOSIA_B/IRQ4_B | Hi-Z | [AGTOA1 selected] AGTOA1 output* ² [Other than the above] Keep-O* ¹ |
| P412/GTOULO_B/SCK0_E/RSPCKA_B | Hi-Z | Keep-O |
| P413/GTOUUP_B/CTS0_RTS0_E/SSLA0_B | Hi-Z | Keep-O |
| P414/GTIOC0B_C/SSLA1_B | Hi-Z | Keep-O |
| P415/GTIOC0A_C/SSLA2_B | Hi-Z | Keep-O |
| P500/GTIU_B/GTIOC2A_B | Hi-Z | Keep-O |
| P501/AN017/GTIV_B/GTIOC2B_B/TXD1_C/MOSI1_C/SDA1_C | Hi-Z | Keep-O |
| P502/AN018/GTIW_B/GTIOC3B_C/RXD1_C/MISO1_C/SCL1_C | Hi-Z | Keep-O |
| P503/AN019/GTETRGA_E/SCK1_C | Hi-Z | Keep-O |
| P504/AN020/GTETRGA_E/CTS1_RTS1_C | Hi-Z | Keep-O |
| P505 | Hi-Z | Keep-O |
| P600/GTIOC6B_C/SCK9_C | Hi-Z | Keep-O |
| P601/GTIOC6A_C/RXD9_C/MISO9_C/SCL9_C | Hi-Z | Keep-O |
| P602/GTIOC7B_B/TXD9_C/MOSI9_C/SDA9_C | Hi-Z | Keep-O |
| P603/GTIOC7A_B/CTS9_RTS9_C | Hi-Z | Keep-O |
| P608/GTIOC4B_C | Hi-Z | Keep-O |

Table 1.1 Port states in each processing mode (4 of 4)

| Port name | Reset | Software Standby Mode |
|------------------------------------|-------|-----------------------|
| P609/GTIOC5A_C | Hi-Z | Keep-O |
| P610/GTIOC5B_C | Hi-Z | Keep-O |
| P708/RXD1_D/MISO1_D/SCL1_D/SSLA3_B | Hi-Z | Keep-O |
| P714 | Hi-Z | Keep-O |
| P808, P809 | Hi-Z | Keep-O |

Note: Hi-Z: High-impedance

Keep-O: Output pins retain their previous values. Input pins become high-impedance.

Note 1. Input is enabled if the pin is specified as the Software Standby canceling source while it is used as an external interrupt pin.

Note 2. AGTIO output is enabled while LOCO or SOSC is selected as a count source.

Appendix 2. Package Dimensions

Information on the latest version of the package dimensions or mountings is displayed in “Packages” on the Renesas Electronics Corporation website.

| JEITA Package Code | RENESAS Code | Previous Code | MASS (Typ) [g] |
|-----------------------|--------------|---------------|----------------|
| P-LFQFP100-14x14-0.50 | PLQP0100KB-B | — | 0.6 |

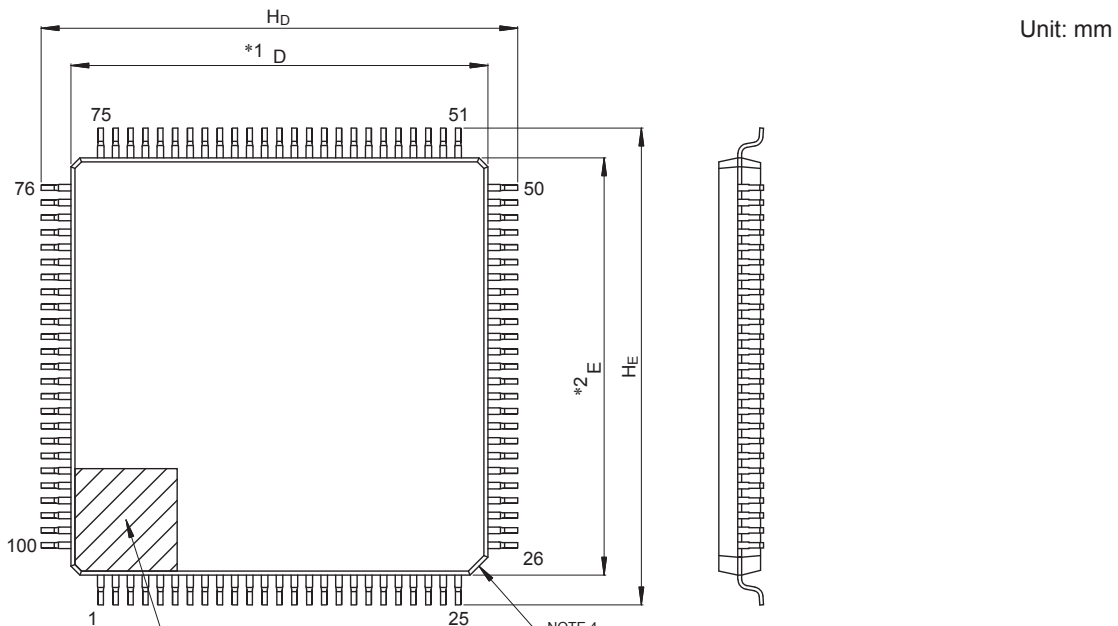

Unit: mm

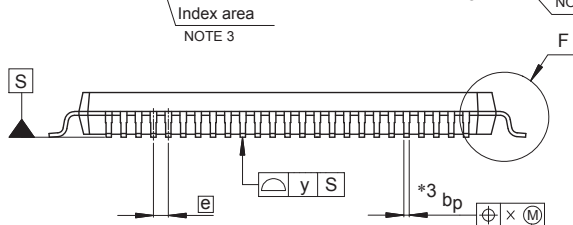

- NOTE)
1. DIMENSIONS “*1” AND “*2” DO NOT INCLUDE MOLD FLASH.
 2. DIMENSION “*3” DOES NOT INCLUDE TRIM OFFSET.
 3. PIN 1 VISUAL INDEX FEATURE MAY VARY, BUT MUST BE LOCATED WITHIN THE HATCHED AREA.
 4. CHAMFERS AT CORNERS ARE OPTIONAL, SIZE MAY VARY.

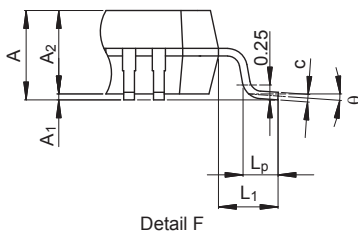

| Reference Symbol | Dimensions in millimeters | | |
|------------------|---------------------------|------|------|
| | Min | Nom | Max |
| D | 13.9 | 14.0 | 14.1 |
| E | 13.9 | 14.0 | 14.1 |
| A ₂ | — | 1.4 | — |
| H _D | 15.8 | 16.0 | 16.2 |
| H _E | 15.8 | 16.0 | 16.2 |
| A | — | — | 1.7 |
| A ₁ | 0.05 | — | 0.15 |
| b _p | 0.15 | 0.20 | 0.27 |
| c | 0.09 | — | 0.20 |
| θ | 0° | 3.5° | 8° |
| e | — | 0.5 | — |
| x | — | — | 0.08 |
| y | — | — | 0.08 |
| L _p | 0.45 | 0.6 | 0.75 |
| L ₁ | — | 1.0 | — |

© 2015 Renesas Electronics Corporation. All rights reserved.

Figure 2.1 LQFP 100-pin

| JEITA Package Code | RENESAS Code | Previous Code | MASS (Typ) [g] |
|----------------------|--------------|---------------|----------------|
| P-LFQFP80-12x12-0.50 | PLQP0080KB-B | — | 0.5 |

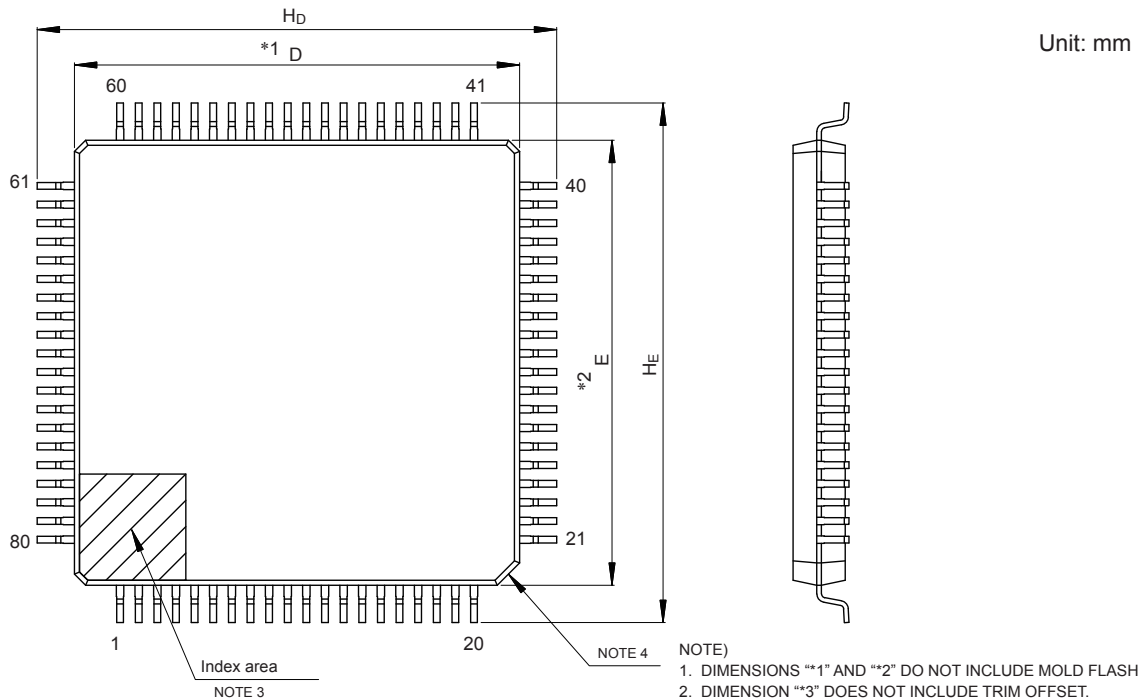

- NOTE)
1. DIMENSIONS **1" AND **2" DO NOT INCLUDE MOLD FLASH.
 2. DIMENSION **3" DOES NOT INCLUDE TRIM OFFSET.
 3. PIN 1 VISUAL INDEX FEATURE MAY VARY, BUT MUST BE LOCATED WITHIN THE HATCHED AREA.
 4. CHAMFERS AT CORNERS ARE OPTIONAL, SIZE MAY VARY.

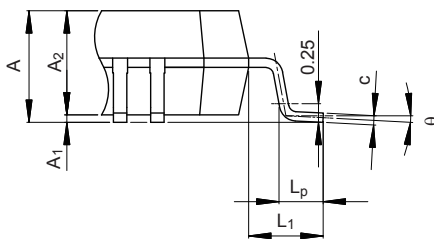
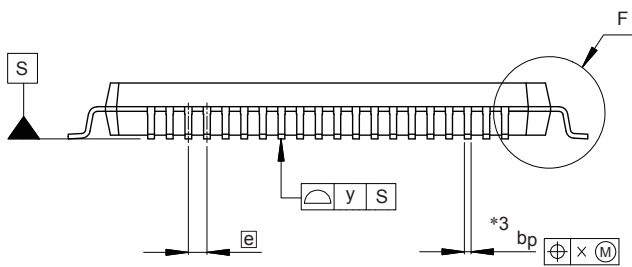

Detail F

| Reference Symbol | Dimensions in millimeters | | |
|------------------|---------------------------|------|------|
| | Min | Nom | Max |
| D | 11.9 | 12.0 | 12.1 |
| E | 11.9 | 12.0 | 12.1 |
| A ₂ | — | 1.4 | — |
| H _D | 13.8 | 14.0 | 14.2 |
| H _E | 13.8 | 14.0 | 14.2 |
| A | — | — | 1.7 |
| A ₁ | 0.05 | — | 0.15 |
| b _p | 0.15 | 0.20 | 0.27 |
| c | 0.09 | — | 0.20 |
| θ | 0° | 3.5° | 8° |
| e | — | 0.5 | — |
| x | — | — | 0.08 |
| y | — | — | 0.08 |
| L _p | 0.45 | 0.6 | 0.75 |
| L ₁ | — | 1.0 | — |

© 2017 Renesas Electronics Corporation. All rights reserved.

Figure 2.2 LQFP 80-pin

| JEITA Package Code | RENESAS Code | Previous Code | MASS (Typ) [g] |
|----------------------|--------------|---------------|----------------|
| P-LFQFP64-10x10-0.50 | PLQP0064KB-C | — | 0.3 |

Unit: mm

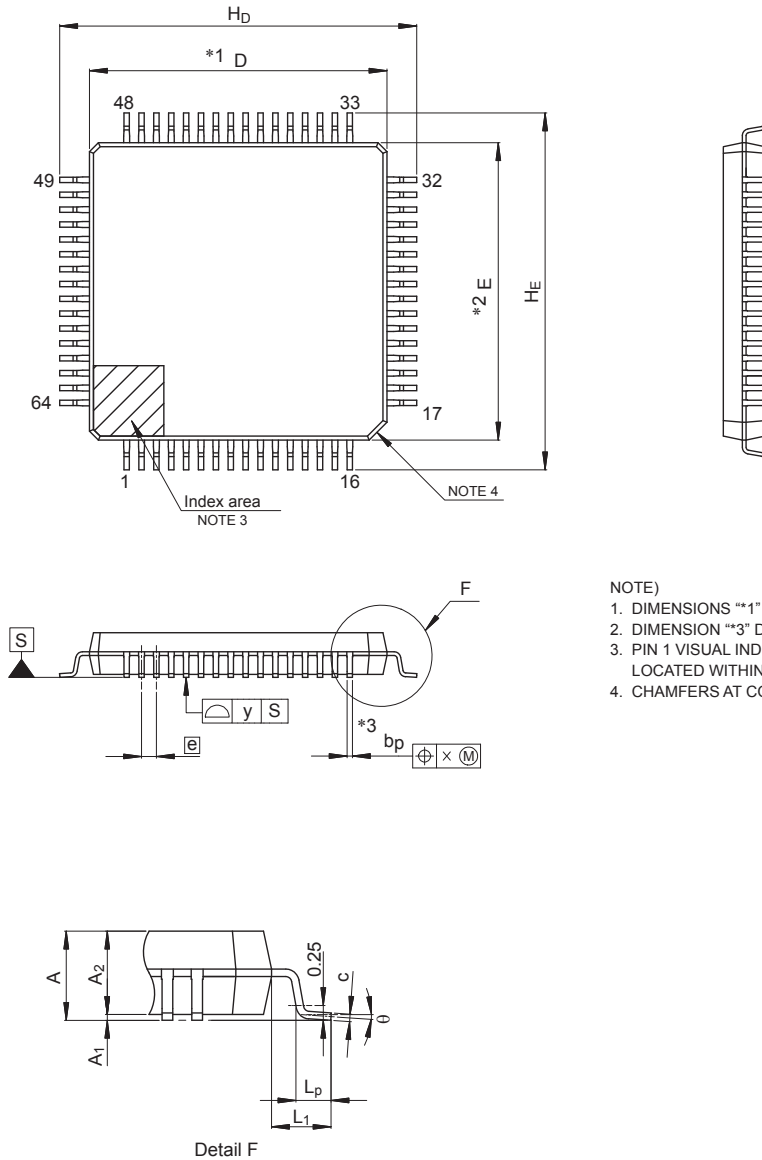

- NOTE)
1. DIMENSIONS **1" AND **2" DO NOT INCLUDE MOLD FLASH.
 2. DIMENSION **3" DOES NOT INCLUDE TRIM OFFSET.
 3. PIN 1 VISUAL INDEX FEATURE MAY VARY, BUT MUST BE LOCATED WITHIN THE HATCHED AREA.
 4. CHAMFERS AT CORNERS ARE OPTIONAL, SIZE MAY VARY.

| Reference Symbol | Dimensions in millimeters | | |
|------------------|---------------------------|------|------|
| | Min | Nom | Max |
| D | 9.9 | 10.0 | 10.1 |
| E | 9.9 | 10.0 | 10.1 |
| A ₂ | — | 1.4 | — |
| H _D | 11.8 | 12.0 | 12.2 |
| H _E | 11.8 | 12.0 | 12.2 |
| A | — | — | 1.7 |
| A ₁ | 0.05 | — | 0.15 |
| b _p | 0.15 | 0.20 | 0.27 |
| c | 0.09 | — | 0.20 |
| θ | 0° | 3.5° | 8° |
| \bar{e} | — | 0.5 | — |
| x | — | — | 0.08 |
| y | — | — | 0.08 |
| L _p | 0.45 | 0.6 | 0.75 |
| L ₁ | — | 1.0 | — |

© 2015 Renesas Electronics Corporation. All rights reserved.

Figure 2.3 LQFP 64-pin (1)

| | | |
|-----------------------|--------------|---------------|
| JEITA Package code | RENESAS code | MASS(TYP.)[g] |
| P-LFQFP064-10x10-0.50 | PLQP0064KL-A | 0.36 |

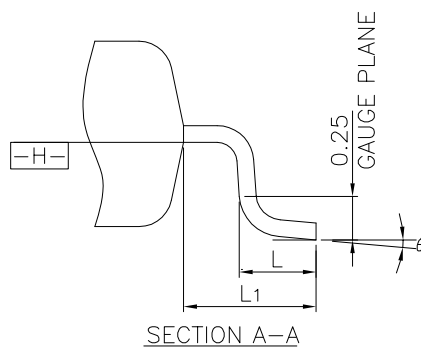
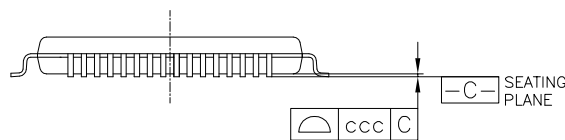
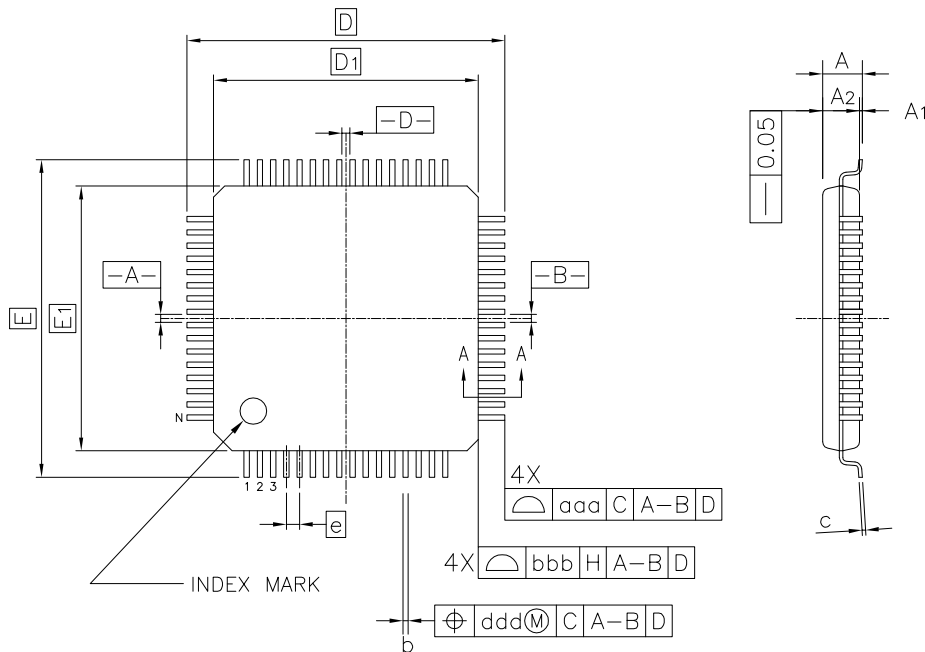

| Reference Symbol | Dimension in Millimeters | | |
|------------------|--------------------------|-------|------|
| | Min. | Nom. | Max. |
| A | — | — | 1.60 |
| A ₁ | 0.05 | — | 0.15 |
| A ₂ | 1.35 | 1.40 | 1.45 |
| D | — | 12.00 | — |
| D ₁ | — | 10.00 | — |
| E | — | 12.00 | — |
| E ₁ | — | 10.00 | — |
| N | — | 64 | — |
| e | — | 0.50 | — |
| b | 0.17 | 0.22 | 0.27 |
| c | 0.09 | — | 0.20 |
| θ | 0° | 3.5° | 7° |
| L | 0.45 | 0.60 | 0.75 |
| L ₁ | — | 1.00 | — |
| aaa | — | — | 0.20 |
| bbb | — | — | 0.20 |
| ccc | — | — | 0.08 |
| ddd | — | — | 0.08 |

Figure 2.4 LQFP 64-pin (2)

| JEITA Package Code | RENESAS Code | Previous Code | MASS (Typ) [g] |
|--------------------|--------------|---------------|----------------|
| P-LFQFP48-7x7-0.50 | PLQP0048KB-B | — | 0.2 |

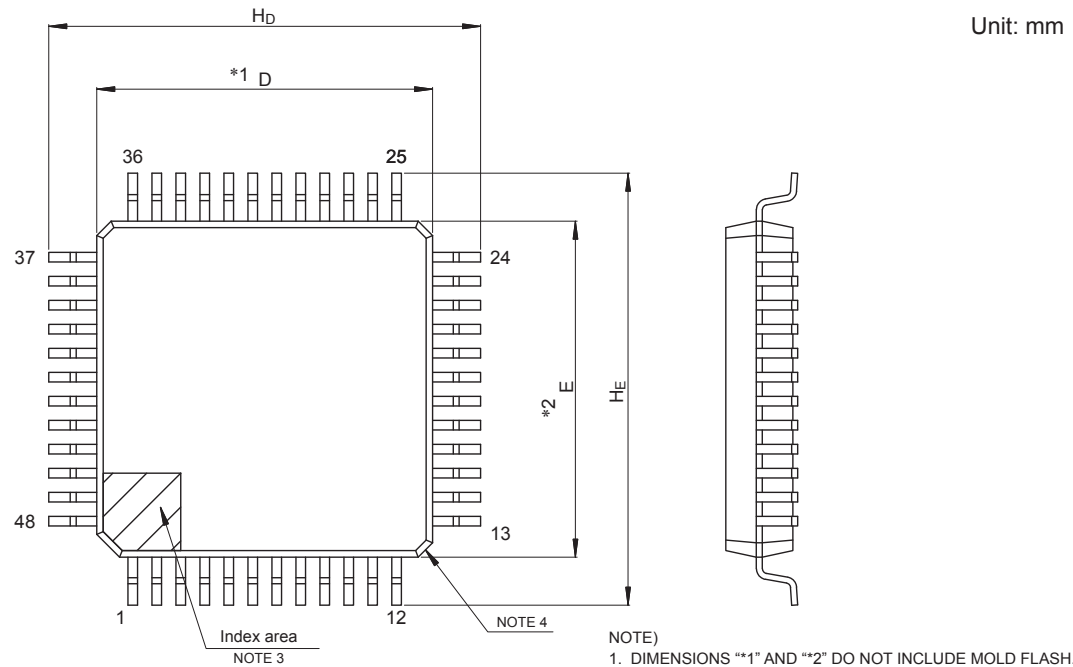

Unit: mm

- NOTE)
1. DIMENSIONS “*1” AND “*2” DO NOT INCLUDE MOLD FLASH.
 2. DIMENSION “*3” DOES NOT INCLUDE TRIM OFFSET.
 3. PIN 1 VISUAL INDEX FEATURE MAY VARY, BUT MUST BE LOCATED WITHIN THE HATCHED AREA.
 4. CHAMFERS AT CORNERS ARE OPTIONAL, SIZE MAY VARY.

| Reference Symbol | Dimensions in millimeters | | |
|------------------|---------------------------|------|------|
| | Min | Nom | Max |
| D | 6.9 | 7.0 | 7.1 |
| E | 6.9 | 7.0 | 7.1 |
| A ₂ | — | 1.4 | — |
| H _D | 8.8 | 9.0 | 9.2 |
| H _E | 8.8 | 9.0 | 9.2 |
| A | — | — | 1.7 |
| A ₁ | 0.05 | — | 0.15 |
| b _p | 0.17 | 0.20 | 0.27 |
| c | 0.09 | — | 0.20 |
| θ | 0° | 3.5° | 8° |
| e | — | 0.5 | — |
| x | — | — | 0.08 |
| y | — | — | 0.08 |
| L _p | 0.45 | 0.6 | 0.75 |
| L ₁ | — | 1.0 | — |

Figure 2.5 LQFP 48-pin (1)

| | | |
|--------------------|--------------|---------------|
| JEITA Package code | RENESAS code | MASS(TYP.)[g] |
| P-LFQFP48-7x7-0.50 | PLQP0048KL-A | 0.18 |

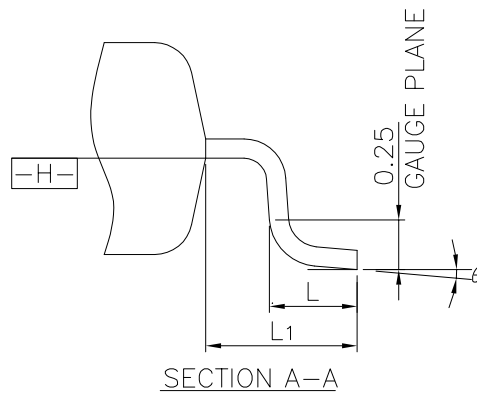
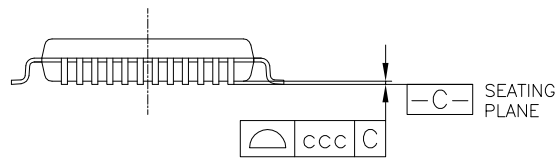
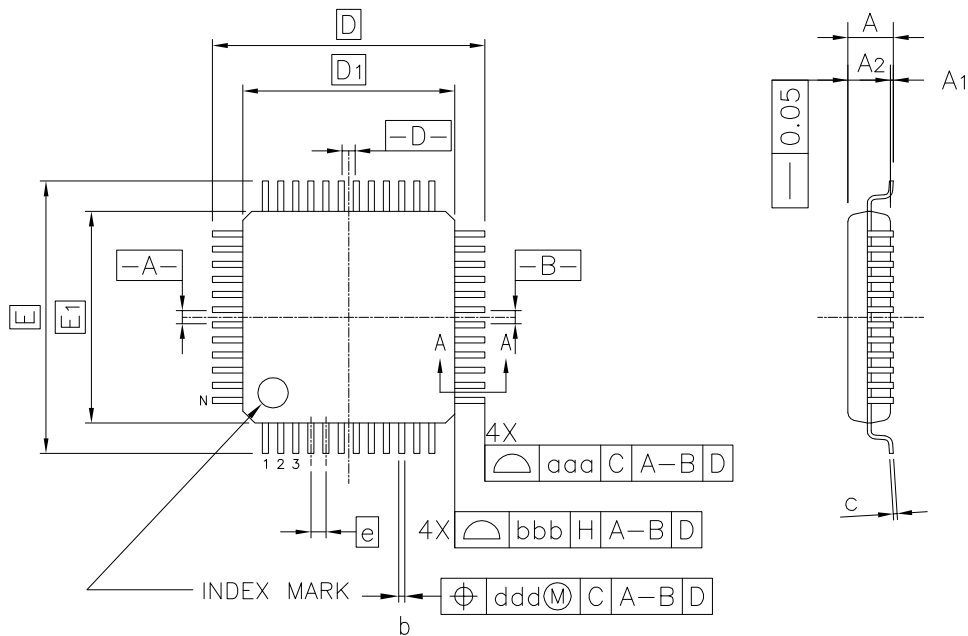

| Reference Symbol | Dimension in Millimeters | | |
|------------------|--------------------------|------|------|
| | Min. | Nom. | Max. |
| A | — | — | 1.60 |
| A ₁ | 0.05 | — | 0.15 |
| A ₂ | 1.35 | 1.40 | 1.45 |
| D | — | 9.00 | — |
| D ₁ | — | 7.00 | — |
| E | — | 9.00 | — |
| E ₁ | — | 7.00 | — |
| N | — | 48 | — |
| e | — | 0.50 | — |
| b | 0.17 | 0.22 | 0.27 |
| c | 0.09 | — | 0.20 |
| θ | 0° | 3.5° | 7° |
| L | 0.45 | 0.60 | 0.75 |
| L ₁ | — | 1.00 | — |
| aaa | — | — | 0.20 |
| bbb | — | — | 0.20 |
| ccc | — | — | 0.08 |
| ddd | — | — | 0.08 |

Figure 2.6 LQFP 48-pin (2)

| | | |
|---------------------|--------------|---------------|
| JEITA Package code | RENESAS code | MASS(TYP.)[g] |
| P-HWQFN048-7x7-0.50 | PWQN0048KC-A | 0.13 g |

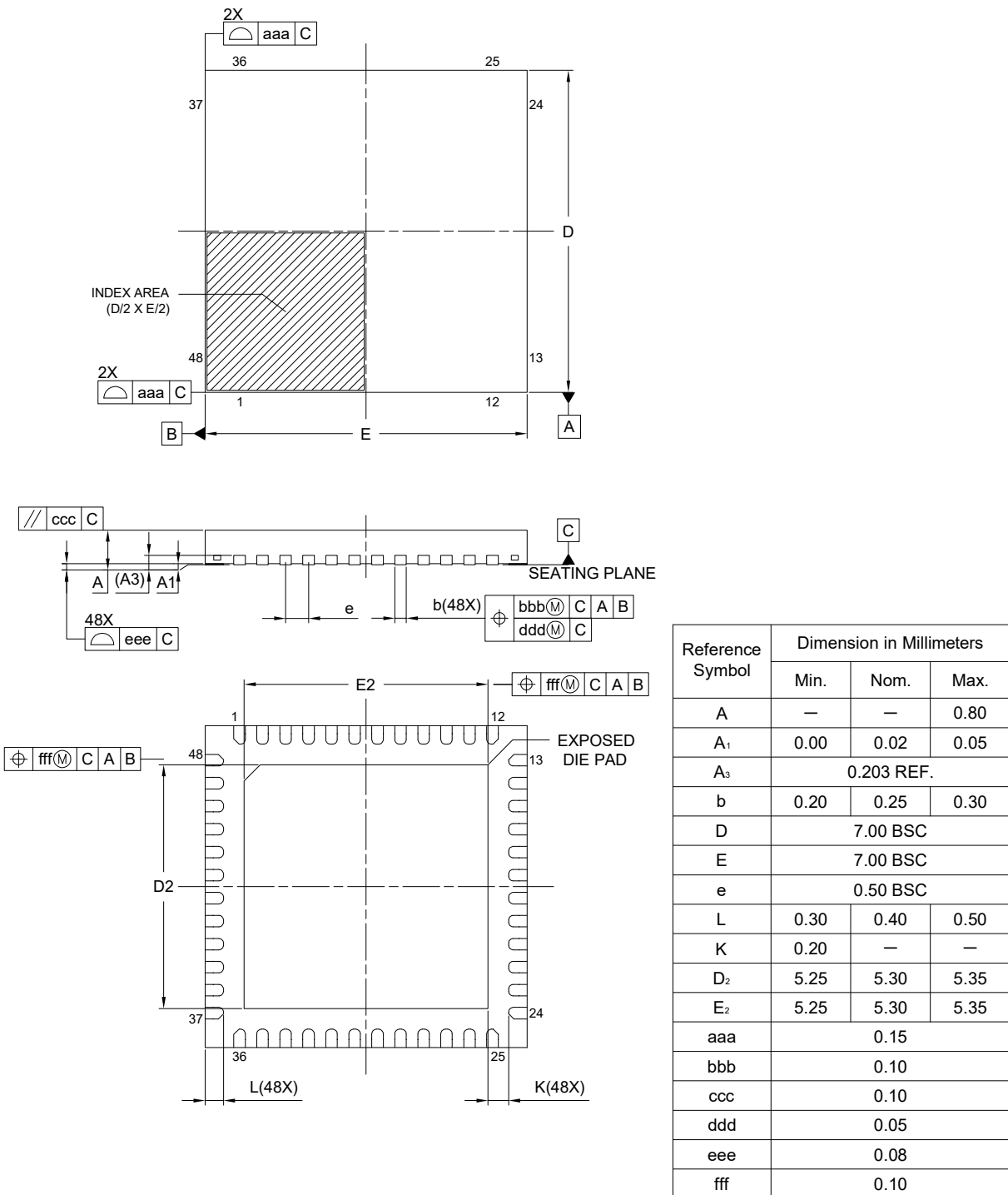

Figure 2.7 HWQFN 48-pin

Appendix 3. I/O Registers

This appendix describes I/O register addresses, access cycles, and reset values by function.

3.1 Peripheral Base Addresses

This section provides the base addresses for peripherals described in this manual.

Table 3.1 shows the name, description, and the base address of each peripheral.

Table 3.1 Peripheral base address (1 of 2)

| Name | Description | Base address |
|--------|--|--------------|
| MPU | Memory Protection Unit | 0x4000_0000 |
| SRAM | SRAM Control | 0x4000_2000 |
| BUS | BUS Control | 0x4000_3000 |
| DTC | Data Transfer Controller | 0x4000_5400 |
| ICU | Interrupt Controller | 0x4000_6000 |
| DBG | Debug Function | 0x4001_B000 |
| SYSC | System Control | 0x4001_E000 |
| PORT0 | Port 0 Control Registers | 0x4004_0000 |
| PORT1 | Port 1 Control Registers | 0x4004_0020 |
| PORT2 | Port 2 Control Registers | 0x4004_0040 |
| PORT3 | Port 3 Control Registers | 0x4004_0060 |
| PORT4 | Port 4 Control Registers | 0x4004_0080 |
| PORT5 | Port 5 Control Registers | 0x4004_00A0 |
| PORT6 | Port 6 Control Registers | 0x4004_00C0 |
| PORT7 | Port 7 Control Registers | 0x4004_00E0 |
| PORT8 | Port 8 Control Registers | 0x4004_0100 |
| PFS | Pmn Pin Function Control Register | 0x4004_0800 |
| ELC | Event Link Controller | 0x4004_1000 |
| POEG | Port Output Enable Module for GPT | 0x4004_2000 |
| RTC | Realtime Clock | 0x4004_4000 |
| WDT | Watchdog Timer | 0x4004_4200 |
| IWDT | Independent Watchdog Timer | 0x4004_4400 |
| CAC | Clock Frequency Accuracy Measurement Circuit | 0x4004_4600 |
| MSTP | Module Stop Control B, C, D | 0x4004_7000 |
| CAN0 | CAN0 Module | 0x4005_0000 |
| IIC0 | Inter-Integrated Circuit 0 | 0x4005_3000 |
| IIC0WU | Inter-Integrated Circuit 0 Wakeup Unit | 0x4005_3014 |
| IIC1 | Inter-Integrated Circuit 1 | 0x4005_3100 |
| DOC | Data Operation Circuit | 0x4005_4100 |
| ADC12 | 12-bit A/D Converter | 0x4005_C000 |
| DAC12 | 12-bit D/A Converter | 0x4005_E000 |
| SCI0 | Serial Communication Interface 0 | 0x4007_0000 |
| SCI1 | Serial Communication Interface 1 | 0x4007_0020 |
| SCI2 | Serial Communication Interface 2 | 0x4007_0040 |
| SCI3 | Serial Communication Interface 3 | 0x4007_0060 |

Table 3.1 Peripheral base address (2 of 2)

| Name | Description | Base address |
|---------|--|--------------|
| SCI9 | Serial Communication Interface 9 | 0x4007_0120 |
| SPI0 | Serial Peripheral Interface 0 | 0x4007_2000 |
| SPI1 | Serial Peripheral Interface 1 | 0x4007_2100 |
| CRC | CRC Calculator | 0x4007_4000 |
| GPT320 | General PWM Timer 0 (32-bit) | 0x4007_8000 |
| GPT321 | General PWM Timer 1 (32-bit) | 0x4007_8100 |
| GPT322 | General PWM Timer 2 (32-bit) | 0x4007_8200 |
| GPT323 | General PWM Timer 3 (32-bit) | 0x4007_8300 |
| GPT164 | General PWM Timer 4 (16-bit) | 0x4007_8400 |
| GPT165 | General PWM Timer 5 (16-bit) | 0x4007_8500 |
| GPT166 | General PWM Timer 6 (16-bit) | 0x4007_8600 |
| GPT167 | General PWM Timer 7 (16-bit) | 0x4007_8700 |
| GPT168 | General PWM Timer 8 (16-bit) | 0x4007_8800 |
| GPT169 | General PWM Timer 9 (16-bit) | 0x4007_8900 |
| GPT_OPS | Output Phase Switching Controller | 0x4007_8FF0 |
| KINT | Key Interrupt Function | 0x4008_0000 |
| CTSU | Capacitive Sensing Unit | 0x4008_2000 |
| AGT0 | Low Power Asynchronous General Purpose Timer 0 | 0x4008_4000 |
| AGT1 | Low Power Asynchronous General Purpose Timer 1 | 0x4008_4100 |
| ACMPLP | Low-Power Analog Comparator | 0x4008_5E00 |
| FLCN | Flash I/O Registers | 0x407E_C000 |

Note: Name = Peripheral name
Description = Peripheral functionality
Base address = Lowest reserved address or address used by the peripheral

3.2 Access Cycles

This section provides access cycle information for the I/O registers described in this manual.

The following information applies to [Table 3.2](#):

- Registers are grouped by associated module.
- The number of access cycles indicates the number of cycles based on the specified reference clock.
- In the internal I/O area, reserved addresses that are not allocated to registers must not be accessed, otherwise operations cannot be guaranteed.
- The number of I/O access cycles depends on bus cycles of the internal peripheral bus, divided clock synchronization cycles, and wait cycles of each module. Divided clock synchronization cycles differ depending on the frequency ratio between ICLK and PCLK.
- When the frequency of ICLK is equal to that of PCLK, the number of divided clock synchronization cycles is always constant.
- When the frequency of ICLK is greater than that of PCLK, at least 1 PCLK cycle is added to the number of divided clock synchronization cycles.

Note: This applies to the number of cycles when access from the CPU does not conflict with the instruction fetching to the external memory or bus access from other bus master such as DTC.

[Table 3.2](#) shows the register access cycles for non-GPT modules.

Table 3.2 Access cycles for non-GPT modules

| Peripherals | Address | | Number of access cycles | | | | Cycle unit | Related function |
|---|-------------|-------------|-------------------------|-------|---------------|-------|------------|---|
| | | | ICLK = PCLK | | ICLK > PCLK*1 | | | |
| | | | Read | Write | Read | Write | | |
| MPU, SRAM, BUS, DTC, ICU, DBG | 0x4000_2000 | 0x4001_BFFF | 3 | | | | ICLK | Memory Protection Unit, SRAM, Buses, Data Transfer Controller, Interrupt Controller, CPU, Flash Memory |
| SYSC | 0x4001_E000 | 0x4001_E6FF | 4 | | | | ICLK | Low Power Modes, Resets, Low Voltage Detection, Clock Generation Circuit, Register Write Protection |
| PORTn, PFS, ELC, POEG, RTC, WDT, IWDT, CAC, MSTP | 0x4004_0000 | 0x4004_7FFF | 3 | | 2 to 3 | | PCLKB | I/O Ports, Event Link Controller, Port Output Enable for GPT, Realtime Clock, Watchdog Timer, Independent Watchdog Timer, Clock Frequency Accuracy Measurement Circuit, Module Stop Control |
| CAN0, IICn (n = 0, 1), IIC0WU, DOC, ADC12, DAC12 | 0x4005_0000 | 0x4005_EFFF | 3 | | 2 to 3 | | PCLKB | Controller Area Network Module, I ² C Bus Interface, Data Operation Circuit, 12-bit A/D Converter, 12-Bit D/A Converter |
| SCIn (n = 0*2 to 3, 9) | 0x4007_0000 | 0x4007_0EFF | 5 | | 2 to 3 | | PCLKB | Serial Communications Interface |
| SPIIn (n = 0, 1)*3 | 0x4007_2000 | 0x4007_2FFF | 5 | | 2 to 3 | | PCLKB | Serial Peripheral Interface |
| CRC | 0x4007_4000 | 0x4007_4FFF | 3 | | 2 to 3 | | PCLKB | CRC Calculator |
| GPT32n (n = 0 to 3), GPT16n (n = 4 to 9), GPT_OPS | 0x4007_8000 | 0x4007_BFFF | See Table 3.3. | | | | PCLKB | General PWM Timer |
| KINT, CTSU | 0x4008_0000 | 0x4008_2FFF | 3 | | 2 to 3 | | PCLKB | Key interrupt Function, Capacitive Sensing Unit |
| AGTn | 0x4008_4000 | 0x4008_4FFF | 3 | | 2 to 3 | | PCLKB | Low Power Asynchronous General Purpose Timer |
| ACMPLP | 0x4008_5000 | 0x4008_6FFF | 3 | | 2 to 3 | | PCLKB | Low-Power Analog Comparator |
| FLCN | 0x407E_C000 | 0x407E_FFFF | 7 | | 7 | | ICLK | Data Flash, Temperature Sensor, Capacitive Sensing Unit, Flash Control |

- Note 1. If the number of PCLK cycles is non-integer (for example 1.5), the minimum value is without the decimal point, and the maximum value is rounded up to the decimal point. For example, 1.5 to 2.5 is 1 to 3.
- Note 2. When accessing a 16-bit register (FTDRHL, FRDRHL, FCR, FDR, LSR, and CDR), access is 2 cycles more than the value shown in Table 3.2. When accessing an 8-bit register (FTDRH, FTDRL, FRDRH, and FRDRL), the access cycles are as shown in Table 3.2.
- Note 3. When accessing the 32-bit register (SPDR), access is 2 cycles more than the value in Table 3.2. When accessing an 8-bit or 16-bit register (SPDR_HA), the access cycles are as shown in Table 3.2.

Table 3.3 shows register access cycles for GPT modules.

Table 3.3 Access cycles for GPT modules

| Frequency ratio between ICLK and PCLK | Number of access cycles | | Cycle unit |
|---------------------------------------|-------------------------|--------|------------|
| | Read | Write | |
| ICLK > PCLKD = PCLKB | 5 to 6 | 3 to 4 | PCLKB |
| ICLK > PCLKD > PCLKB | 3 to 4 | 2 to 3 | PCLKB |
| PCLKD = ICLK = PCLKB | 6 | 4 | PCLKB |
| PCLKD = ICLK > PCLKB | 2 to 3 | 1 to 2 | PCLKB |
| PCLKD > ICLK = PCLKB | 4 | 3 | PCLKB |
| PCLKD > ICLK > PCLKB | 2 to 3 | 1 to 2 | PCLKB |

3.3 Register Descriptions

This section provides information associated with registers described in this manual.

Table 3.4 shows a list of registers including address offsets, address sizes, access rights, and reset values.

Table 3.4 Register description (1 of 15)

| Peripheral name | Dim | Dim inc. | Dim index | Register name | Description | Address offset | Size | R/W | Reset value | Reset mask |
|-----------------|-----|----------|-----------|---------------|--|----------------|------|-----|-------------|------------|
| MPU | — | — | — | MMPUCTLA | Bus Master MPU Control Register | 0x000 | 16 | R/W | 0x0000 | 0xFFFF |
| MPU | — | — | — | MMPUPTA | Group A Protection of Register | 0x102 | 16 | R/W | 0x0000 | 0xFFFF |
| MPU | 4 | 0x010 | 0-3 | MMPUACA%s | Group A Region %s access control register | 0x200 | 16 | R/W | 0x0000 | 0xFFFF |
| MPU | 4 | 0x010 | 0-3 | MMPUSA%s | Group A Region %s Start Address Register | 0x204 | 32 | R/W | 0x00000000 | 0x00000003 |
| MPU | 4 | 0x010 | 0-3 | MMPUEA%s | Group A Region %s End Address Register | 0x208 | 32 | R/W | 0x00000003 | 0x00000003 |
| MPU | — | — | — | SMPUCTL | Slave MPU Control Register | 0xC00 | 16 | R/W | 0x0000 | 0xFFFF |
| MPU | — | — | — | SMPUMBIU | Access Control Register for Memory Bus 1 | 0xC10 | 16 | R/W | 0x0000 | 0xFFFF |
| MPU | — | — | — | SMPUFBIU | Access Control Register for Internal Peripheral Bus 9 | 0xC14 | 16 | R/W | 0x0000 | 0xFFFF |
| MPU | — | — | — | SMPUSRAM0 | Access Control Register for Memory Bus 4 | 0xC18 | 16 | R/W | 0x0000 | 0xFFFF |
| MPU | — | — | — | SMPUP0BIU | Access Control Register for Internal Peripheral Bus 1 | 0xC20 | 16 | R/W | 0x0000 | 0xFFFF |
| MPU | — | — | — | SMPUP2BIU | Access Control Register for Internal Peripheral Bus 3 | 0xC24 | 16 | R/W | 0x0000 | 0xFFFF |
| MPU | — | — | — | SMPUP6BIU | Access Control Register for Internal Peripheral Bus 7 | 0xC28 | 16 | R/W | 0x0000 | 0xFFFF |
| MPU | — | — | — | MSPMPUOAD | Stack Pointer Monitor Operation After Detection Register | 0xD00 | 16 | R/W | 0x0000 | 0xFFFF |
| MPU | — | — | — | MSPMPUCTL | Stack Pointer Monitor Access Control Register | 0xD04 | 16 | R/W | 0x0000 | 0xFEFF |
| MPU | — | — | — | MSPMPUPT | Stack Pointer Monitor Protection Register | 0xD06 | 16 | R/W | 0x0000 | 0xFFFF |
| MPU | — | — | — | MSPMPUSA | Main Stack Pointer (MSP) Monitor Start Address Register | 0xD08 | 32 | R/W | 0x00000000 | 0x00000000 |
| MPU | — | — | — | MSPMPUEA | Main Stack Pointer (MSP) Monitor End Address Register | 0xD0C | 32 | R/W | 0x00000000 | 0x00000000 |
| MPU | — | — | — | PSPMPUOAD | Stack Pointer Monitor Operation After Detection Register | 0xD10 | 16 | R/W | 0x0000 | 0xFFFF |
| MPU | — | — | — | PSPMPUCTL | Stack Pointer Monitor Access Control Register | 0xD14 | 16 | R/W | 0x0000 | 0xFEFF |
| MPU | — | — | — | PSPMPUPT | Stack Pointer Monitor Protection Register | 0xD16 | 16 | R/W | 0x0000 | 0xFFFF |
| MPU | — | — | — | PSPMPUSA | Process Stack Pointer (PSP) Monitor Start Address Register | 0xD18 | 32 | R/W | 0x00000000 | 0x00000000 |
| MPU | — | — | — | PSPMPUEA | Process Stack Pointer (PSP) Monitor End Address Register | 0xD1C | 32 | R/W | 0x00000000 | 0x00000000 |
| SRAM | — | — | — | PARIOAD | SRAM Parity Error Operation After Detection Register | 0x00 | 8 | R/W | 0x00 | 0xFF |
| SRAM | — | — | — | SRAMPRCR | SRAM Protection Register | 0x04 | 8 | R/W | 0x00 | 0xFF |
| SRAM | — | — | — | ECCMODE | ECC Operating Mode Control Register | 0xC0 | 8 | R/W | 0x00 | 0xFF |
| SRAM | — | — | — | ECC2STS | ECC 2-Bit Error Status Register | 0xC1 | 8 | R/W | 0x00 | 0xFF |
| SRAM | — | — | — | ECC1STSEN | ECC 1-Bit Error Information Update Enable Register | 0xC2 | 8 | R/W | 0x00 | 0xFF |
| SRAM | — | — | — | ECC1STS | ECC 1-Bit Error Status Register | 0xC3 | 8 | R/W | 0x00 | 0xFF |
| SRAM | — | — | — | ECCETST | ECC Test Control Register | 0xC4 | 8 | R/W | 0x00 | 0xFF |
| SRAM | — | — | — | ECCPRCR | ECC Protection Register | 0xC4 | 8 | R/W | 0x00 | 0xFF |
| SRAM | — | — | — | ECCPRCR2 | ECC Protection Register 2 | 0xD0 | 8 | R/W | 0x00 | 0xFF |
| SRAM | — | — | — | ECCOAD | SRAM ECC Error Operation After Detection Register | 0xD8 | 8 | R/W | 0x00 | 0xFF |

Table 3.4 Register description (2 of 15)

| Peripheral name | Dim | Dim inc. | Dim index | Register name | Description | Address offset | Size | R/W | Reset value | Reset mask |
|-----------------|-----|----------|-----------|---------------|---|----------------|------|-----|--------------|------------|
| BUS | — | — | — | BUSMCNTSYS | Master Bus Control Register SYS | 0x1008 | 16 | R/W | 0x0000 | 0xFFFF |
| BUS | — | — | — | BUSMCNTDMA | Master Bus Control Register DMA | 0x100C | 16 | R/W | 0x0000 | 0xFFFF |
| BUS | — | — | — | BUS3ERRADD | Bus Error Address Register 3 | 0x1820 | 32 | R | 0x00000000 | 0x00000000 |
| BUS | — | — | — | BUS3ERRSTAT | BUS Error Status Register 3 | 0x1824 | 8 | R | 0x00 | 0xFE |
| BUS | — | — | — | BUS4ERRADD | Bus Error Address Register 4 | 0x1830 | 32 | R | 0x00000000 | 0x00000000 |
| BUS | — | — | — | BUS4ERRSTAT | BUS Error Status Register 4 | 0x1834 | 8 | R | 0x00 | 0xFE |
| DTC | — | — | — | DTCCR | DTC Control Register | 0x00 | 8 | R/W | 0x08 | 0xFF |
| DTC | — | — | — | DTCVBR | DTC Vector Base Register | 0x04 | 32 | R/W | 0x00000000 | 0xFFFFFFFF |
| DTC | — | — | — | DTCST | DTC Module Start Register | 0x0C | 8 | R/W | 0x00 | 0xFF |
| DTC | — | — | — | DTCSTS | DTC Status Register | 0x0E | 16 | R | 0x0000 | 0xFFFF |
| ICU | 8 | 0x1 | 0-7 | IRQCR%s | IRQ Control Register | 0x000 | 8 | R/W | 0x00 | 0xFF |
| ICU | — | — | — | NMICR | NMI Pin Interrupt Control Register | 0x100 | 8 | R/W | 0x00 | 0xFF |
| ICU | — | — | — | NMIER | Non-Maskable Interrupt Enable Register | 0x120 | 16 | R/W | 0x0000 | 0xFFFF |
| ICU | — | — | — | NMICLR | Non-Maskable Interrupt Status Clear Register | 0x130 | 16 | R/W | 0x0000 | 0xFFFF |
| ICU | — | — | — | NMISR | Non-Maskable Interrupt Status Register | 0x140 | 16 | R | 0x0000 | 0xFFFF |
| ICU | — | — | — | WUPEN | Wake Up Interrupt Enable Register | 0x1A0 | 32 | R/W | 0x00000000 | 0xFFFFFFFF |
| ICU | — | — | — | IELEN | ICU event Enable Register | 0x1C0 | 8 | R/W | 0x00 | 0xFF |
| ICU | — | — | — | SELSR0 | SYS Event Link Setting Register | 0x200 | 16 | R/W | 0x0000 | 0xFFFF |
| ICU | 32 | 0x4 | 0-31 | IELSR%s | ICU Event Link Setting Register %s | 0x300 | 32 | R/W | 0x00000000 | 0xFFFFFFFF |
| DBG | — | — | — | DBGSTR | Debug Status Register | 0x00 | 32 | R | 0x00000000 | 0xFFFFFFFF |
| DBG | — | — | — | DBGSTOPCR | Debug Stop Control Register | 0x10 | 32 | R/W | 0x00000003 | 0xFFFFFFFF |
| SYSC | — | — | — | SBYCR | Standby Control Register | 0x00C | 16 | R/W | 0x0000 | 0xFFFF |
| SYSC | — | — | — | MSTPCRA | Module Stop Control Register A | 0x01C | 32 | R/W | 0xFFBFFFFFFF | 0xFFFFFFFF |
| SYSC | — | — | — | SCKDIVCR | System Clock Division Control Register | 0x020 | 32 | R/W | 0x04000404 | 0xFFFFFFFF |
| SYSC | — | — | — | SCKSCR | System Clock Source Control Register | 0x026 | 8 | R/W | 0x01 | 0xFF |
| SYSC | — | — | — | MEMWAIT | Memory Wait Cycle Control Register for Code Flash | 0x031 | 8 | R/W | 0x00 | 0xFF |
| SYSC | — | — | — | MOSCCR | Main Clock Oscillator Control Register | 0x032 | 8 | R/W | 0x01 | 0xFF |
| SYSC | — | — | — | HOCOOCR | High-Speed On-Chip Oscillator Control Register | 0x036 | 8 | R/W | 0x00 | 0xFE |
| SYSC | — | — | — | MOCOOCR | Middle-Speed On-Chip Oscillator Control Register | 0x038 | 8 | R/W | 0x00 | 0xFF |
| SYSC | — | — | — | OSCSF | Oscillation Stabilization Flag Register | 0x03C | 8 | R | 0x00 | 0xFE |
| SYSC | — | — | — | CKOCR | Clock Out Control Register | 0x03E | 8 | R/W | 0x00 | 0xFF |
| SYSC | — | — | — | OSTDCR | Oscillation Stop Detection Control Register | 0x040 | 8 | R/W | 0x00 | 0xFF |
| SYSC | — | — | — | OSTDSR | Oscillation Stop Detection Status Register | 0x041 | 8 | R/W | 0x00 | 0xFF |
| SYSC | — | — | — | LPOPT | Lower Power Operation Control Register | 0x04C | 8 | R/W | 0x00 | 0xFF |
| SYSC | — | — | — | MOCOUTCR | MOCO User Trimming Control Register | 0x061 | 8 | R/W | 0x00 | 0xFF |
| SYSC | — | — | — | HOCOUTCR | HOCO User Trimming Control Register | 0x062 | 8 | R/W | 0x00 | 0xFF |
| SYSC | — | — | — | SNZCR | Snooze Control Register | 0x092 | 8 | R/W | 0x00 | 0xFF |
| SYSC | — | — | — | SNZEDCR0 | Snooze End Control Register 0 | 0x094 | 8 | R/W | 0x00 | 0xFF |
| SYSC | — | — | — | SNZREQCR0 | Snooze Request Control Register 0 | 0x098 | 32 | R/W | 0x00000000 | 0xFFFFFFFF |
| SYSC | — | — | — | PSMCR | Power Save Memory Control Register | 0x09F | 8 | R/W | 0x00 | 0xFF |
| SYSC | — | — | — | OPCCR | Operating Power Control Register | 0x0A0 | 8 | R/W | 0x01 | 0xFF |
| SYSC | — | — | — | MOSCWTCR | Main Clock Oscillator Wait Control Register | 0x0A2 | 8 | R/W | 0x05 | 0xFF |
| SYSC | — | — | — | SOPCCR | Sub Operating Power Control Register | 0x0AA | 8 | R/W | 0x00 | 0xFF |

Table 3.4 Register description (3 of 15)

| Peripheral name | Dim | Dim inc. | Dim index | Register name | Description | Address offset | Size | R/W | Reset value | Reset mask |
|-----------------|-----|----------|-----------|---------------|---|----------------|------|-----|-------------|------------|
| SYSC | — | — | — | RSTSR1 | Reset Status Register 1 | 0x0C0 | 16 | R/W | 0x0000 | 0xE0F8 |
| SYSC | — | — | — | LVD1CR1 | Voltage Monitor 1 Circuit Control Register | 0x0E0 | 8 | R/W | 0x01 | 0xFF |
| SYSC | — | — | — | LVD1SR | Voltage Monitor 1 Circuit Status Register | 0x0E1 | 8 | R/W | 0x02 | 0xFF |
| SYSC | — | — | — | LVD2CR1 | Voltage Monitor 2 Circuit Control Register 1 | 0x0E2 | 8 | R/W | 0x01 | 0xFF |
| SYSC | — | — | — | LVD2SR | Voltage Monitor 2 Circuit Status Register | 0x0E3 | 8 | R/W | 0x02 | 0xFF |
| SYSC | — | — | — | PRCR | Protect Register | 0x3FE | 16 | R/W | 0x0000 | 0xFFFF |
| SYSC | — | — | — | SYOCDRCR | System Control OCD Control Register | 0x040E | 8 | R/W | 0x00 | 0xFF |
| SYSC | — | — | — | RSTSR0 | Reset Status Register 0 | 0x410 | 8 | R/W | 0x00 | 0xF0 |
| SYSC | — | — | — | RSTSR2 | Reset Status Register 2 | 0x411 | 8 | R/W | 0x00 | 0xFE |
| SYSC | — | — | — | MOMCR | Main Clock Oscillator Mode Oscillation Control Register | 0x413 | 8 | R/W | 0x00 | 0xFF |
| SYSC | — | — | — | LVCMPCR | Voltage Monitor Circuit Control Register | 0x417 | 8 | R/W | 0x00 | 0xFF |
| SYSC | — | — | — | LVDLVLRLR | Voltage Detection Level Select Register | 0x418 | 8 | R/W | 0x07 | 0xFF |
| SYSC | — | — | — | LVD1CR0 | Voltage Monitor 1 Circuit Control Register 0 | 0x41A | 8 | R/W | 0x80 | 0xF7 |
| SYSC | — | — | — | LVD2CR0 | Voltage Monitor 2 Circuit Control Register 0 | 0x41B | 8 | R/W | 0x80 | 0xF7 |
| SYSC | — | — | — | DCDCCTL | DCDC/LDO Control Register | 0x440 | 8 | R/W | 0xC0 | 0xFF |
| SYSC | — | — | — | VCCSEL | Voltage Level Selection Control Register | 0x441 | 8 | R/W | 0x00 | 0xFF |
| SYSC | — | — | — | SOSCCR | Sub-Clock Oscillator Control Register | 0x480 | 8 | R/W | 0x01 | 0xFF |
| SYSC | — | — | — | SOMCR | Sub-Clock Oscillator Mode Control Register | 0x481 | 8 | R/W | 0x00 | 0xFF |
| SYSC | — | — | — | SOMRG | Sub-Clock Oscillator Margin Check Register | 0x482 | 8 | R/W | 0x00 | 0xFF |
| SYSC | — | — | — | LOCOCR | Low-Speed On-Chip Oscillator Control Register | 0x490 | 8 | R/W | 0x00 | 0xFF |
| SYSC | — | — | — | LOCOUTCR | LOCO User Trimming Control Register | 0x492 | 8 | R/W | 0x00 | 0xFF |
| PORT0,3-8 | — | — | — | PCNTR1 | Port Control Register 1 | 0x000 | 32 | R/W | 0x00000000 | 0xFFFFFFFF |
| PORT0,3-8 | — | — | — | PODR | Port Control Register 1 | 0x000 | 16 | R/W | 0x0000 | 0xFFFF |
| PORT0,3-8 | — | — | — | PDR | Port Control Register 1 | 0x002 | 16 | R/W | 0x0000 | 0xFFFF |
| PORT0,3-8 | — | — | — | PCNTR2 | Port Control Register 2 | 0x004 | 32 | R | 0x00000000 | 0xFFFF0000 |
| PORT0,3-8 | — | — | — | PIDR | Port Control Register 2 | 0x006 | 16 | R | 0x0000 | 0x0000 |
| PORT0,3-8 | — | — | — | PCNTR3 | Port Control Register 3 | 0x008 | 32 | W | 0x00000000 | 0xFFFFFFFF |
| PORT0,3-8 | — | — | — | PORR | Port Control Register 3 | 0x008 | 16 | W | 0x0000 | 0xFFFF |
| PORT0,3-8 | — | — | — | POSR | Port Control Register 3 | 0x00A | 16 | W | 0x0000 | 0xFFFF |
| PORT1-2 | — | — | — | PCNTR1 | Port Control Register 1 | 0x000 | 32 | R/W | 0x00000000 | 0xFFFFFFFF |
| PORT1-2 | — | — | — | PODR | Port Control Register 1 | 0x000 | 16 | R/W | 0x0000 | 0xFFFF |
| PORT1-2 | — | — | — | PDR | Port Control Register 1 | 0x002 | 16 | R/W | 0x0000 | 0xFFFF |
| PORT1-2 | — | — | — | PCNTR2 | Port Control Register 2 | 0x004 | 32 | R | 0x00000000 | 0xFFFF0000 |
| PORT1-2 | — | — | — | EIDR | Port Control Register 2 | 0x004 | 16 | R | 0x0000 | 0xFFFF |
| PORT1-2 | — | — | — | PIDR | Port Control Register 2 | 0x006 | 16 | R | 0x0000 | 0x0000 |
| PORT1-2 | — | — | — | PCNTR3 | Port Control Register 3 | 0x008 | 32 | W | 0x00000000 | 0xFFFFFFFF |
| PORT1-2 | — | — | — | PORR | Port Control Register 3 | 0x008 | 16 | W | 0x0000 | 0xFFFF |
| PORT1-2 | — | — | — | POSR | Port Control Register 3 | 0x00A | 16 | W | 0x0000 | 0xFFFF |
| PORT1-2 | — | — | — | PCNTR4 | Port Control Register 4 | 0x00C | 32 | R/W | 0x00000000 | 0xFFFFFFFF |
| PORT1-2 | — | — | — | EORR | Port Control Register 4 | 0x00C | 16 | R/W | 0x0000 | 0xFFFF |
| PORT1-2 | — | — | — | EOSR | Port Control Register 4 | 0x00E | 16 | R/W | 0x0000 | 0xFFFF |

Table 3.4 Register description (4 of 15)

| Peripheral name | Dim | Dim inc. | Dim index | Register name | Description | Address offset | Size | R/W | Reset value | Reset mask |
|-----------------|-----|----------|-----------|---------------|---------------------------------------|----------------|------|-----|-------------|------------|
| PFS | 9 | 0x4 | 0-8 | P00%PFS | Port 00% Pin Function Select Register | 0x000 | 32 | R/W | 0x00000000 | 0xFFFFFFFF |
| PFS | 9 | 0x4 | 0-8 | P00%PFS_HA | Port 00% Pin Function Select Register | 0x002 | 16 | R/W | 0x0000 | 0xFFFF |
| PFS | 9 | 0x4 | 0-8 | P00%PFS_BY | Port 00% Pin Function Select Register | 0x003 | 8 | R/W | 0x00 | 0xFD |
| PFS | 6 | 0x4 | 10-15 | P0%PFS | Port 0% Pin Function Select Register | 0x028 | 32 | R/W | 0x00000000 | 0xFFFFFFFF |
| PFS | 6 | 0x4 | 10-15 | P0%PFS_HA | Port 0% Pin Function Select Register | 0x02A | 16 | R/W | 0x0000 | 0xFFFF |
| PFS | 6 | 0x4 | 10-15 | P0%PFS_BY | Port 0% Pin Function Select Register | 0x02B | 8 | R/W | 0x00 | 0xFD |
| PFS | 8 | 0x4 | 0-7 | P10%PFS | Port 10% Pin Function Select Register | 0x040 | 32 | R/W | 0x00000000 | 0xFFFFFFFF |
| PFS | 8 | 0x4 | 0-7 | P10%PFS_HA | Port 10% Pin Function Select Register | 0x042 | 16 | R/W | 0x0000 | 0xFFFF |
| PFS | 8 | 0x4 | 0-7 | P10%PFS_BY | Port 10% Pin Function Select Register | 0x043 | 8 | R/W | 0x00 | 0xFD |
| PFS | — | — | — | P108PFS | Port 108 Pin Function Select Register | 0x060 | 32 | R/W | 0x00010010 | 0xFFFFFFFF |
| PFS | — | — | — | P108PFS_HA | Port 108 Pin Function Select Register | 0x062 | 16 | R/W | 0x0010 | 0xFFFF |
| PFS | — | — | — | P108PFS_BY | Port 108 Pin Function Select Register | 0x063 | 8 | R/W | 0x10 | 0xFD |
| PFS | — | — | — | P109PFS | Port 109 Pin Function Select Register | 0x064 | 32 | R/W | 0x00000000 | 0xFFFFFFFF |
| PFS | — | — | — | P109PFS_HA | Port 109 Pin Function Select Register | 0x066 | 16 | R/W | 0x0000 | 0xFFFF |
| PFS | — | — | — | P109PFS_BY | Port 109 Pin Function Select Register | 0x067 | 8 | R/W | 0x00 | 0xFD |
| PFS | 6 | 0x4 | 10-15 | P1%PFS | Port 1% Pin Function Select Register | 0x068 | 32 | R/W | 0x00000000 | 0xFFFFFFFF |
| PFS | 6 | 0x4 | 10-15 | P1%PFS_HA | Port 1% Pin Function Select Register | 0x06A | 16 | R/W | 0x0000 | 0xFFFF |
| PFS | 6 | 0x4 | 10-15 | P1%PFS_BY | Port 1% Pin Function Select Register | 0x06B | 8 | R/W | 0x00 | 0xFD |
| PFS | — | — | — | P200PFS | Port 200 Pin Function Select Register | 0x080 | 32 | R/W | 0x00000000 | 0xFFFFFFFF |
| PFS | — | — | — | P200PFS_HA | Port 200 Pin Function Select Register | 0x082 | 16 | R/W | 0x0000 | 0xFFFF |
| PFS | — | — | — | P200PFS_BY | Port 200 Pin Function Select Register | 0x083 | 8 | R/W | 0x00 | 0xFD |
| PFS | — | — | — | P201PFS | Port 201 Pin Function Select Register | 0x084 | 32 | R/W | 0x00000010 | 0xFFFFFFFF |
| PFS | — | — | — | P201PFS_HA | Port 201 Pin Function Select Register | 0x086 | 16 | R/W | 0x0010 | 0xFFFF |
| PFS | — | — | — | P201PFS_BY | Port 201 Pin Function Select Register | 0x087 | 8 | R/W | 0x10 | 0xFD |
| PFS | 7 | 0x4 | 2-8 | P20%PFS | Port 20% Pin Function Select Register | 0x088 | 32 | R/W | 0x00000000 | 0xFFFFFFFF |
| PFS | 7 | 0x4 | 2-8 | P20%PFS_HA | Port 20% Pin Function Select Register | 0x08A | 16 | R/W | 0x0000 | 0xFFFF |
| PFS | 7 | 0x4 | 2-8 | P20%PFS_BY | Port 20% Pin Function Select Register | 0x08B | 8 | R/W | 0x00 | 0xFD |
| PFS | 4 | 0x4 | 12-15 | P2%PFS | Port 2% Pin Function Select Register | 0x0B0 | 32 | R/W | 0x00000000 | 0xFFFFFFFF |
| PFS | 4 | 0x4 | 12-15 | P2%PFS_HA | Port 2% Pin Function Select Register | 0x0B2 | 16 | R/W | 0x0000 | 0xFFFF |
| PFS | 4 | 0x4 | 12-15 | P2%PFS_BY | Port 2% Pin Function Select Register | 0x0B3 | 8 | R/W | 0x00 | 0xFD |
| PFS | — | — | — | P300PFS | Port 300 Pin Function Select Register | 0x0C0 | 32 | R/W | 0x00010000 | 0xFFFFFFFF |
| PFS | — | — | — | P300PFS_HA | Port 300 Pin Function Select Register | 0x0C2 | 16 | R/W | 0x0000 | 0xFFFF |
| PFS | — | — | — | P300PFS_BY | Port 300 Pin Function Select Register | 0x0C3 | 8 | R/W | 0x00 | 0xFD |
| PFS | 7 | 0x4 | 1-7 | P30%PFS | Port 30% Pin Function Select Register | 0x0C4 | 32 | R/W | 0x00000000 | 0xFFFFFFFF |
| PFS | 7 | 0x4 | 1-7 | P30%PFS_HA | Port 30% Pin Function Select Register | 0x0C6 | 16 | R/W | 0x0000 | 0xFFFF |
| PFS | 7 | 0x4 | 1-7 | P30%PFS_BY | Port 30% Pin Function Select Register | 0x0C7 | 8 | R/W | 0x00 | 0xFD |
| PFS | 10 | 0x4 | 0-9 | P40%PFS | Port 40% Pin Function Select Register | 0x100 | 32 | R/W | 0x00000000 | 0xFFFFFFFF |
| PFS | 10 | 0x4 | 0-9 | P40%PFS_HA | Port 40% Pin Function Select Register | 0x102 | 16 | R/W | 0x0000 | 0xFFFF |
| PFS | 10 | 0x4 | 0-9 | P40%PFS_BY | Port 40% Pin Function Select Register | 0x103 | 8 | R/W | 0x00 | 0xFD |
| PFS | 6 | 0x4 | 10-15 | P4%PFS | Port 4% Pin Function Select Register | 0x128 | 32 | R/W | 0x00000000 | 0xFFFFFFFF |
| PFS | 6 | 0x4 | 10-15 | P4%PFS_HA | Port 4% Pin Function Select Register | 0x12A | 16 | R/W | 0x0000 | 0xFFFF |
| PFS | 6 | 0x4 | 10-15 | P4%PFS_BY | Port 4% Pin Function Select Register | 0x12B | 8 | R/W | 0x00 | 0xFD |
| PFS | 6 | 0x4 | 0-5 | P50%PFS | Port 50% Pin Function Select Register | 0x140 | 32 | R/W | 0x00000000 | 0xFFFFFFFF |
| PFS | 6 | 0x4 | 0-5 | P50%PFS_HA | Port 50% Pin Function Select Register | 0x142 | 16 | R/W | 0x0000 | 0xFFFF |
| PFS | 6 | 0x4 | 0-5 | P50%PFS_BY | Port 50% Pin Function Select Register | 0x143 | 8 | R/W | 0x00 | 0xFD |

Table 3.4 Register description (5 of 15)

| Peripheral name | Dim | Dim inc. | Dim index | Register name | Description | Address offset | Size | R/W | Reset value | Reset mask |
|-----------------|-----|----------|-----------|---------------|--|----------------|------|-----|-------------|------------|
| PFS | 4 | 0x4 | 0-3 | P60%PFS | Port 60% Pin Function Select Register | 0x180 | 32 | R/W | 0x00000000 | 0xFFFFFFFF |
| PFS | 4 | 0x4 | 0-3 | P60%PFS_HA | Port 60% Pin Function Select Register | 0x182 | 16 | R/W | 0x0000 | 0xFFFF |
| PFS | 4 | 0x4 | 0-3 | P60%PFS_BY | Port 60% Pin Function Select Register | 0x183 | 8 | R/W | 0x00 | 0xFD |
| PFS | 2 | 0x4 | 8-9 | P60%PFS | Port 60% Pin Function Select Register | 0x1A0 | 32 | R/W | 0x00000000 | 0xFFFFFFFF |
| PFS | 2 | 0x4 | 8-9 | P60%PFS_HA | Port 60% Pin Function Select Register | 0x1A2 | 16 | R/W | 0x0000 | 0xFFFF |
| PFS | 2 | 0x4 | 8-9 | P60%PFS_BY | Port 60% Pin Function Select Register | 0x1A3 | 8 | R/W | 0x00 | 0xFD |
| PFS | — | — | — | P610PFS | Port 610 Pin Function Select Register | 0x1A8 | 32 | R/W | 0x00000000 | 0xFFFFFFFF |
| PFS | — | — | — | P610PFS_HA | Port 610 Pin Function Select Register | 0x1AA | 16 | R/W | 0x0000 | 0xFFFF |
| PFS | — | — | — | P610PFS_BY | Port 610 Pin Function Select Register | 0x1AB | 8 | R/W | 0x00 | 0xFD |
| PFS | — | — | — | P708PFS | Port 708 Pin Function Select Register | 0x1E0 | 32 | R/W | 0x00000000 | 0xFFFFFFFF |
| PFS | — | — | — | P708PFS_HA | Port 708 Pin Function Select Register | 0x1E2 | 16 | R/W | 0x0000 | 0xFFFF |
| PFS | — | — | — | P708PFS_BY | Port 708 Pin Function Select Register | 0x1E3 | 8 | R/W | 0x00 | 0xFD |
| PFS | — | — | — | P714PFS | Port 714 Pin Function Select Register | 0x1F8 | 32 | R/W | 0x00000000 | 0xFFFFFFFF |
| PFS | — | — | — | P714PFS_HA | Port 714 Pin Function Select Register | 0x1FA | 16 | R/W | 0x0000 | 0xFFFF |
| PFS | — | — | — | P714PFS_BY | Port 714 Pin Function Select Register | 0x1FB | 8 | R/W | 0x00 | 0xFD |
| PFS | 2 | 0x4 | 8-9 | P80%PFS | Port 80% Pin Function Select Register | 0x220 | 32 | R/W | 0x00000000 | 0xFFFFFFFF |
| PFS | 2 | 0x4 | 8-9 | P80%PFS_HA | Port 80% Pin Function Select Register | 0x222 | 16 | R/W | 0x0000 | 0xFFFF |
| PFS | 2 | 0x4 | 8-9 | P80%PFS_BY | Port 80% Pin Function Select Register | 0x223 | 8 | R/W | 0x00 | 0xFD |
| PFS | — | — | — | PWPR | Write-Protect Register | 0x503 | 8 | R/W | 0x80 | 0xFF |
| PFS | — | — | — | PRWCNTR | Port Read Wait Control Register | 0x50F | 8 | R/W | 0x01 | 0xFF |
| ELC | — | — | — | ELCR | Event Link Controller Register | 0x00 | 8 | R/W | 0x00 | 0xFF |
| ELC | 2 | 0x02 | 0-1 | ELSEGR% | Event Link Software Event Generation Register %s | 0x02 | 8 | R/W | 0x80 | 0xFF |
| ELC | 4 | 0x04 | 0-3 | ELSR% | Event Link Setting Register %s | 0x10 | 16 | R/W | 0x0000 | 0xFFFF |
| ELC | 2 | 0x04 | 8-9 | ELSR% | Event Link Setting Register %s | 0x30 | 16 | R/W | 0x0000 | 0xFFFF |
| ELC | — | — | — | ELSR12 | Event Link Setting Register 12 | 0x40 | 16 | R/W | 0x0000 | 0xFFFF |
| ELC | 2 | 0x04 | 14-15 | ELSR% | Event Link Setting Register %s | 0x48 | 16 | R/W | 0x0000 | 0xFFFF |
| ELC | — | — | — | ELSR18 | Event Link Setting Register 18 | 0x58 | 16 | R/W | 0x0000 | 0xFFFF |
| POEG | — | — | — | POEGGA | POEG Group A Setting Register | 0x000 | 32 | R/W | 0x00000000 | 0xFFFFFFFF |
| POEG | — | — | — | POEGGB | POEG Group B Setting Register | 0x100 | 32 | R/W | 0x00000000 | 0xFFFFFFFF |
| RTC | — | — | — | R64CNT | 64-Hz Counter | 0x00 | 8 | R | 0x00 | 0x00 |
| RTC | 4 | 0x02 | 0-3 | BCNT% | Binary Counter %s | 0x02 | 8 | R/W | 0x00 | 0x00 |
| RTC | — | — | — | RSECCNT | Second Counter (in Calendar Count Mode) | 0x02 | 8 | R/W | 0x00 | 0x00 |
| RTC | — | — | — | RMINCNT | Minute Counter (in Calendar Count Mode) | 0x04 | 8 | R/W | 0x00 | 0x00 |
| RTC | — | — | — | RHRCNT | Hour Counter (in Calendar Count Mode) | 0x06 | 8 | R/W | 0x00 | 0x00 |
| RTC | — | — | — | RWKCNT | Day-of-Week Counter (in Calendar Count Mode) | 0x08 | 8 | R/W | 0x00 | 0x00 |
| RTC | — | — | — | RDAYCNT | Day Counter | 0x0A | 8 | R/W | 0x00 | 0xC0 |
| RTC | — | — | — | RMONCNT | Month Counter | 0x0C | 8 | R/W | 0x00 | 0xE0 |
| RTC | — | — | — | RYRCNT | Year Counter | 0x0E | 16 | R/W | 0x0000 | 0xFF00 |
| RTC | 4 | 0x02 | 0-3 | BCNT%AR | Binary Counter %s Alarm Register | 0x10 | 8 | R/W | 0x00 | 0x00 |
| RTC | — | — | — | RSECAR | Second Alarm Register (in Calendar Count Mode) | 0x10 | 8 | R/W | 0x00 | 0x00 |
| RTC | — | — | — | RMINAR | Minute Alarm Register (in Calendar Count Mode) | 0x12 | 8 | R/W | 0x00 | 0x00 |
| RTC | — | — | — | RHRAR | Hour Alarm Register (in Calendar Count Mode) | 0x14 | 8 | R/W | 0x00 | 0x00 |

Table 3.4 Register description (6 of 15)

| Peripheral name | Dim | Dim inc. | Dim index | Register name | Description | Address offset | Size | R/W | Reset value | Reset mask |
|-----------------|-----|----------|-----------|---------------|---|----------------|------|-----|-------------|------------|
| RTC | — | — | — | RWKAR | Day-of-Week Alarm Register (in Calendar Count Mode) | 0x16 | 8 | R/W | 0x00 | 0x00 |
| RTC | 2 | 0x02 | 0-1 | BCNT%sAER | Binary Counter %s Alarm Enable Register | 0x18 | 8 | R/W | 0x00 | 0x00 |
| RTC | — | — | — | RDAYAR | Date Alarm Register (in Calendar Count Mode) | 0x18 | 8 | R/W | 0x00 | 0x00 |
| RTC | — | — | — | RMONAR | Month Alarm Register (in Calendar Count Mode) | 0x1A | 8 | R/W | 0x00 | 0x00 |
| RTC | — | — | — | BCNT2AER | Binary Counter 2 Alarm Enable Register | 0x1C | 16 | R/W | 0x0000 | 0xFF00 |
| RTC | — | — | — | RYRAR | Year Alarm Register (in Calendar Count Mode) | 0x1C | 16 | R/W | 0x0000 | 0xFF00 |
| RTC | — | — | — | BCNT3AER | Binary Counter 3 Alarm Enable Register | 0x1E | 8 | R/W | 0x00 | 0x00 |
| RTC | — | — | — | RYRAREN | Year Alarm Enable Register (in Calendar Count Mode) | 0x1E | 8 | R/W | 0x00 | 0x00 |
| RTC | — | — | — | RCR1 | RTC Control Register 1 | 0x22 | 8 | R/W | 0x00 | 0x0A |
| RTC | — | — | — | RCR2 | RTC Control Register 2 (in Calendar Count Mode) | 0x24 | 8 | R/W | 0x00 | 0x0E |
| RTC | — | — | — | RCR2 | RTC Control Register 2 (in Binary Count Mode) | 0x24 | 8 | R/W | 0x00 | 0x0E |
| RTC | — | — | — | RCR4 | RTC Control Register 4 | 0x28 | 8 | R/W | 0x00 | 0x7E |
| RTC | — | — | — | RFRH | Frequency Register H | 0x2A | 16 | R/W | 0x0000 | 0xFFFFE |
| RTC | — | — | — | RFRL | Frequency Register L | 0x2C | 16 | R/W | 0x0000 | 0x0000 |
| RTC | — | — | — | RADJ | Time Error Adjustment Register | 0x2E | 8 | R/W | 0x00 | 0x00 |
| WDT | — | — | — | WDTRR | WDT Refresh Register | 0x00 | 8 | R/W | 0xFF | 0xFF |
| WDT | — | — | — | WDCR | WDT Control Register | 0x02 | 16 | R/W | 0x0000 | 0xFFFF |
| WDT | — | — | — | WDSR | WDT Status Register | 0x04 | 16 | R/W | 0x0000 | 0xFFFF |
| WDT | — | — | — | WDTRCR | WDT Reset Control Register | 0x06 | 8 | R/W | 0x80 | 0xFF |
| WDT | — | — | — | WDCSTPR | WDT Count Stop Control Register | 0x08 | 8 | R/W | 0x80 | 0xFF |
| IWDT | — | — | — | IWDTRR | IWDT Refresh Register | 0x00 | 8 | R/W | 0xFF | 0xFF |
| IWDT | — | — | — | IWDSR | IWDT Status Register | 0x04 | 16 | R/W | 0x0000 | 0xFFFF |
| CAC | — | — | — | CACR0 | CAC Control Register 0 | 0x00 | 8 | R/W | 0x00 | 0xFF |
| CAC | — | — | — | CACR1 | CAC Control Register 1 | 0x01 | 8 | R/W | 0x00 | 0xFF |
| CAC | — | — | — | CACR2 | CAC Control Register 2 | 0x02 | 8 | R/W | 0x00 | 0xFF |
| CAC | — | — | — | CAICR | CAC Interrupt Control Register | 0x03 | 8 | R/W | 0x00 | 0xFF |
| CAC | — | — | — | CASTR | CAC Status Register | 0x04 | 8 | R | 0x00 | 0xFF |
| CAC | — | — | — | CAULVR | CAC Upper-Limit Value Setting Register | 0x06 | 16 | R/W | 0x0000 | 0xFFFF |
| CAC | — | — | — | CALLVR | CAC Lower-Limit Value Setting Register | 0x08 | 16 | R/W | 0x0000 | 0xFFFF |
| CAC | — | — | — | CACNTBR | CAC Counter Buffer Register | 0x0A | 16 | R | 0x0000 | 0xFFFF |
| MSTP | — | — | — | MSTPCRB | Module Stop Control Register B | 0x000 | 32 | R/W | 0xFFFFFFFF | 0xFFFFFFFF |
| MSTP | — | — | — | MSTPCRC | Module Stop Control Register C | 0x004 | 32 | R/W | 0xFFFFFFFF | 0xFFFFFFFF |
| MSTP | — | — | — | MSTPCRD | Module Stop Control Register D | 0x008 | 32 | R/W | 0xFFFFFFFF | 0xFFFFFFFF |
| MSTP | — | — | — | LSMRWDIS | Low Speed Module R/W Disable Control Register | 0x00C | 16 | R/W | 0x0000 | 0xFFFF |
| CAN0 | 32 | 0x10 | 0-31 | MB%s_ID | Mailbox ID Register %s | 0x200 | 32 | R/W | 0x00000000 | 0x00000001 |
| CAN0 | 32 | 0x10 | 0-31 | MB%s_DL | Mailbox Data Length Register %s | 0x204 | 16 | R/W | 0x0000 | 0x0000 |
| CAN0 | 32 | 0x10 | 0-31 | MB%s_D0 | Mailbox Data Register %s | 0x206 | 8 | R/W | 0x00 | 0x00 |
| CAN0 | 32 | 0x10 | 0-31 | MB%s_D1 | Mailbox Data Register %s | 0x207 | 8 | R/W | 0x00 | 0x00 |
| CAN0 | 32 | 0x10 | 0-31 | MB%s_D2 | Mailbox Data Register %s | 0x208 | 8 | R/W | 0x00 | 0x00 |
| CAN0 | 32 | 0x10 | 0-31 | MB%s_D3 | Mailbox Data Register %s | 0x209 | 8 | R/W | 0x00 | 0x00 |
| CAN0 | 32 | 0x10 | 0-31 | MB%s_D4 | Mailbox Data Register %s | 0x20A | 8 | R/W | 0x00 | 0x00 |

Table 3.4 Register description (7 of 15)

| Peripheral name | Dim | Dim inc. | Dim index | Register name | Description | Address offset | Size | R/W | Reset value | Reset mask |
|-----------------|-----|----------|-----------|---------------|---|----------------|------|-----|-------------|------------|
| CAN0 | 32 | 0x10 | 0-31 | MB%s_D5 | Mailbox Data Register %s | 0x20B | 8 | R/W | 0x00 | 0x00 |
| CAN0 | 32 | 0x10 | 0-31 | MB%s_D6 | Mailbox Data Register %s | 0x20C | 8 | R/W | 0x00 | 0x00 |
| CAN0 | 32 | 0x10 | 0-31 | MB%s_D7 | Mailbox Data Register %s | 0x20D | 8 | R/W | 0x00 | 0x00 |
| CAN0 | 32 | 0x10 | 0-31 | MB%s_TS | Mailbox Time Stamp Register %s | 0x20E | 16 | R/W | 0x0000 | 0x0000 |
| CAN0 | 8 | 0x04 | — | MKR[%s] | Mask Register %s | 0x400 | 32 | R/W | 0x00000000 | 0x00000000 |
| CAN0 | 2 | 0x04 | 0-1 | FIDCR%s | FIFO Received ID Compare Register %s | 0x420 | 32 | R/W | 0x00000000 | 0x00000000 |
| CAN0 | — | — | — | MKIVLR | Mask Invalid Register | 0x428 | 32 | R/W | 0x00000000 | 0x00000000 |
| CAN0 | — | — | — | MIER | Mailbox Interrupt Enable Register | 0x42C | 32 | R/W | 0x00000000 | 0x00000000 |
| CAN0 | — | — | — | MIER_FIFO | Mailbox Interrupt Enable Register for FIFO Mailbox Mode | 0x42C | 32 | R/W | 0x00000000 | 0x00000000 |
| CAN0 | 32 | 0x01 | — | MCTL_RX[%s] | Message Control Register for Receive | 0x820 | 8 | R/W | 0x00 | 0xFF |
| CAN0 | 32 | 0x01 | — | MCTL_TX[%s] | Message Control Register for Transmit | 0x820 | 8 | R/W | 0x00 | 0xFF |
| CAN0 | — | — | — | CTLR | Control Register | 0x840 | 16 | R/W | 0x0500 | 0xFFFF |
| CAN0 | — | — | — | STR | Status Register | 0x842 | 16 | R | 0x0500 | 0xFFFF |
| CAN0 | — | — | — | BCR | Bit Configuration Register | 0x844 | 32 | R/W | 0x00000000 | 0xFFFFFFFF |
| CAN0 | — | — | — | RFCR | Receive FIFO Control Register | 0x848 | 8 | R/W | 0x80 | 0xFF |
| CAN0 | — | — | — | RFPCR | Receive FIFO Pointer Control Register | 0x849 | 8 | W | 0x00 | 0x00 |
| CAN0 | — | — | — | TFCR | Transmit FIFO Control Register | 0x84A | 8 | R/W | 0x80 | 0xFF |
| CAN0 | — | — | — | TFPCR | Transmit FIFO Pointer Control Register | 0x84B | 8 | W | 0x00 | 0x00 |
| CAN0 | — | — | — | EIER | Error Interrupt Enable Register | 0x84C | 8 | R/W | 0x00 | 0xFF |
| CAN0 | — | — | — | EIFR | Error Interrupt Factor Judge Register | 0x84D | 8 | R/W | 0x00 | 0xFF |
| CAN0 | — | — | — | RECR | Receive Error Count Register | 0x84E | 8 | R | 0x00 | 0xFF |
| CAN0 | — | — | — | TECR | Transmit Error Count Register | 0x84F | 8 | R | 0x00 | 0xFF |
| CAN0 | — | — | — | ECSR | Error Code Store Register | 0x850 | 8 | R/W | 0x00 | 0xFF |
| CAN0 | — | — | — | CSSR | Channel Search Support Register | 0x851 | 8 | R/W | 0x00 | 0x00 |
| CAN0 | — | — | — | MSSR | Mailbox Search Status Register | 0x852 | 8 | R | 0x80 | 0xFF |
| CAN0 | — | — | — | MSMR | Mailbox Search Mode Register | 0x853 | 8 | R/W | 0x00 | 0xFF |
| CAN0 | — | — | — | TSR | Time Stamp Register | 0x854 | 16 | R | 0x0000 | 0xFFFF |
| CAN0 | — | — | — | AFSR | Acceptance Filter Support Register | 0x856 | 16 | R/W | 0x0000 | 0x0000 |
| CAN0 | — | — | — | TCR | Test Control Register | 0x858 | 8 | R/W | 0x00 | 0xFF |
| IIC0-1 | — | — | — | ICCR1 | I2C Bus Control Register 1 | 0x00 | 8 | R/W | 0x1F | 0xFF |
| IIC0-1 | — | — | — | ICCR2 | I2C Bus Control Register 2 | 0x01 | 8 | R/W | 0x00 | 0xFF |
| IIC0-1 | — | — | — | ICMR1 | I2C Bus Mode Register 1 | 0x02 | 8 | R/W | 0x08 | 0xFF |
| IIC0-1 | — | — | — | ICMR2 | I2C Bus Mode Register 2 | 0x03 | 8 | R/W | 0x06 | 0xFF |
| IIC0-1 | — | — | — | ICMR3 | I2C Bus Mode Register 3 | 0x04 | 8 | R/W | 0x00 | 0xFF |
| IIC0-1 | — | — | — | ICFER | I2C Bus Function Enable Register | 0x05 | 8 | R/W | 0x72 | 0xFF |
| IIC0-1 | — | — | — | ICSER | I2C Bus Status Enable Register | 0x06 | 8 | R/W | 0x09 | 0xFF |
| IIC0-1 | — | — | — | ICIER | I2C Bus Interrupt Enable Register | 0x07 | 8 | R/W | 0x00 | 0xFF |
| IIC0-1 | — | — | — | ICSR1 | I2C Bus Status Register 1 | 0x08 | 8 | R/W | 0x00 | 0xFF |
| IIC0-1 | — | — | — | ICSR2 | I2C Bus Status Register 2 | 0x09 | 8 | R/W | 0x00 | 0xFF |
| IIC0-1 | 3 | 0x02 | 0-2 | SARL%s | Slave Address Register Ly | 0x0A | 8 | R/W | 0x00 | 0xFF |
| IIC0-1 | 3 | 0x02 | 0-2 | SARU%s | Slave Address Register Uy | 0x0B | 8 | R/W | 0x00 | 0xFF |
| IIC0-1 | — | — | — | ICBRL | I2C Bus Bit Rate Low-Level Register | 0x10 | 8 | R/W | 0xFF | 0xFF |
| IIC0-1 | — | — | — | ICBRH | I2C Bus Bit Rate High-Level Register | 0x11 | 8 | R/W | 0xFF | 0xFF |
| IIC0-1 | — | — | — | ICDRT | I2C Bus Transmit Data Register | 0x12 | 8 | R/W | 0xFF | 0xFF |
| IIC0-1 | — | — | — | ICDRR | I2C Bus Receive Data Register | 0x13 | 8 | R | 0x00 | 0xFF |

Table 3.4 Register description (8 of 15)

| Peripheral name | Dim | Dim inc. | Dim index | Register name | Description | Address offset | Size | R/W | Reset value | Reset mask |
|-----------------|-----|----------|-----------|---------------|--|----------------|------|-----|-------------|------------|
| IIC0WU | — | — | — | ICWUR | I2C Bus Wakeup Unit Register | 0x02 | 8 | R/W | 0x10 | 0xFF |
| IIC0WU | — | — | — | ICWUR2 | I2C Bus Wakeup Unit Register 2 | 0x03 | 8 | R/W | 0xFD | 0xFF |
| DOC | — | — | — | DOCR | DOC Control Register | 0x00 | 8 | R/W | 0x00 | 0xFF |
| DOC | — | — | — | DODIR | DOC Data Input Register | 0x02 | 16 | R/W | 0x0000 | 0xFFFF |
| DOC | — | — | — | DODSR | DOC Data Setting Register | 0x04 | 16 | R/W | 0x0000 | 0xFFFF |
| ADC12 | — | — | — | ADCSR | A/D Control Register | 0x000 | 16 | R/W | 0x0000 | 0xFFFF |
| ADC12 | — | — | — | ADANSA0 | A/D Channel Select Register A0 | 0x004 | 16 | R/W | 0x0000 | 0xFFFF |
| ADC12 | — | — | — | ADANSA1 | A/D Channel Select Register A1 | 0x006 | 16 | R/W | 0x0000 | 0xFFFF |
| ADC12 | — | — | — | ADADS0 | A/D-Converted Value Addition/Average Channel Select Register 0 | 0x008 | 16 | R/W | 0x0000 | 0xFFFF |
| ADC12 | — | — | — | ADADS1 | A/D-Converted Value Addition/Average Channel Select Register 1 | 0x00A | 16 | R/W | 0x0000 | 0xFFFF |
| ADC12 | — | — | — | ADADC | A/D-Converted Value Addition/Average Count Select Register | 0x00C | 8 | R/W | 0x00 | 0xFF |
| ADC12 | — | — | — | ADCER | A/D Control Extended Register | 0x00E | 16 | R/W | 0x0000 | 0xFFFF |
| ADC12 | — | — | — | ADSTRGR | A/D Conversion Start Trigger Select Register | 0x010 | 16 | R/W | 0x0000 | 0xFFFF |
| ADC12 | — | — | — | ADEXICR | A/D Conversion Extended Input Control Registers | 0x012 | 16 | R/W | 0x0000 | 0xFFFF |
| ADC12 | — | — | — | ADANSB0 | A/D Channel Select Register B0 | 0x014 | 16 | R/W | 0x0000 | 0xFFFF |
| ADC12 | — | — | — | ADANSB1 | A/D Channel Select Register B1 | 0x016 | 16 | R/W | 0x0000 | 0xFFFF |
| ADC12 | — | — | — | ADDBLDR | A/D Data Duplexing Register | 0x018 | 16 | R | 0x0000 | 0xFFFF |
| ADC12 | — | — | — | ADTSDR | A/D Temperature Sensor Data Register | 0x01A | 16 | R | 0x0000 | 0xFFFF |
| ADC12 | — | — | — | ADOCDR | A/D Internal Reference Voltage Data Register | 0x01C | 16 | R | 0x0000 | 0xFFFF |
| ADC12 | — | — | — | ADRD | A/D Self-Diagnosis Data Register | 0x01E | 16 | R | 0x0000 | 0xFFFF |
| ADC12 | 15 | 0x2 | 0-14 | ADDR%s | A/D Data Registers %s | 0x020 | 16 | R | 0x0000 | 0xFFFF |
| ADC12 | — | — | — | ADCTDR | A/D CTSU TSCAP Voltage Data Register | 0x040 | 16 | R | 0x0000 | 0xFFFF |
| ADC12 | 4 | 0x2 | 17-20 | ADDR%s | A/D Data Registers %s | 0x042 | 16 | R | 0x0000 | 0xFFFF |
| ADC12 | — | — | — | ADDISCR | A/D Disconnection Detection Control Register | 0x07A | 8 | R/W | 0x00 | 0xFF |
| ADC12 | — | — | — | ADACSR | A/D Conversion Operation Mode Select Register | 0x07E | 8 | R/W | 0x00 | 0xFF |
| ADC12 | — | — | — | ADGSPCR | A/D Group Scan Priority Control Register | 0x080 | 16 | R/W | 0x0000 | 0xFFFF |
| ADC12 | — | — | — | ADDBLDRA | A/D Data Duplexing Register A | 0x084 | 16 | R | 0x0000 | 0xFFFF |
| ADC12 | — | — | — | ADDBLDRB | A/D Data Duplexing Register B | 0x086 | 16 | R | 0x0000 | 0xFFFF |
| ADC12 | — | — | — | ADHVREFCNT | A/D High-Potential/Low-Potential Reference Voltage Control Register | 0x08A | 8 | R/W | 0x00 | 0xFF |
| ADC12 | — | — | — | ADWINMON | A/D Compare Function Window A/B Status Monitor Register | 0x08C | 8 | R | 0x00 | 0xFF |
| ADC12 | — | — | — | ADCMPCR | A/D Compare Function Control Register | 0x090 | 16 | R/W | 0x0000 | 0xFFFF |
| ADC12 | — | — | — | ADCMPANSER | A/D Compare Function Window A Extended Input Select Register | 0x092 | 8 | R/W | 0x00 | 0xFF |
| ADC12 | — | — | — | ADCMPLER | A/D Compare Function Window A Extended Input Comparison Condition Setting Register | 0x093 | 8 | R/W | 0x00 | 0xFF |
| ADC12 | — | — | — | ADCMPANSR0 | A/D Compare Function Window A Channel Select Register 0 | 0x094 | 16 | R/W | 0x0000 | 0xFFFF |
| ADC12 | — | — | — | ADCMPANSR1 | A/D Compare Function Window A Channel Select Register 1 | 0x096 | 16 | R/W | 0x0000 | 0xFFFF |
| ADC12 | — | — | — | ADCMPLR0 | A/D Compare Function Window A Comparison Condition Setting Register 0 | 0x098 | 16 | R/W | 0x0000 | 0xFFFF |

Table 3.4 Register description (9 of 15)

| Peripheral name | Dim | Dim inc. | Dim index | Register name | Description | Address offset | Size | R/W | Reset value | Reset mask |
|-----------------|-----|----------|-----------|---------------|--|----------------|------|-----|-------------|------------|
| ADC12 | — | — | — | ADCMPPLR1 | A/D Compare Function Window A Comparison Condition Setting Register 1 | 0x09A | 16 | R/W | 0x0000 | 0xFFFF |
| ADC12 | 2 | 0x2 | 0-1 | ADCMPDR%s | A/D Compare Function Window A Lower-Side/Upper-Side Level Setting Register | 0x09C | 16 | R/W | 0x0000 | 0xFFFF |
| ADC12 | — | — | — | ADCMPSR0 | A/D Compare Function Window A Channel Status Register 0 | 0x0A0 | 16 | R/W | 0x0000 | 0xFFFF |
| ADC12 | — | — | — | ADCMPSR1 | A/D Compare Function Window A Channel Status Register1 | 0x0A2 | 16 | R/W | 0x0000 | 0xFFFF |
| ADC12 | — | — | — | ADCMPSER | A/D Compare Function Window A Extended Input Channel Status Register | 0x0A4 | 8 | R/W | 0x00 | 0xFF |
| ADC12 | — | — | — | ADCMPBNSR | A/D Compare Function Window B Channel Select Register | 0x0A6 | 8 | R/W | 0x00 | 0xFF |
| ADC12 | — | — | — | ADWINLLB | A/D Compare Function Window B Lower-Side/Upper-Side Level Setting Register | 0x0A8 | 16 | R/W | 0x0000 | 0xFFFF |
| ADC12 | — | — | — | ADWINULB | A/D Compare Function Window B Lower-Side/Upper-Side Level Setting Register | 0x0AA | 16 | R/W | 0x0000 | 0xFFFF |
| ADC12 | — | — | — | ADCMPBSR | A/D Compare Function Window B Status Register | 0x0AC | 8 | R/W | 0x00 | 0xFF |
| ADC12 | — | — | — | ADSSTRL | A/D Sampling State Register | 0x0DD | 8 | R/W | 0x0D | 0xFF |
| ADC12 | — | — | — | ADSSTRT | A/D Sampling State Register | 0x0DE | 8 | R/W | 0x0D | 0xFF |
| ADC12 | — | — | — | ADSSTRO | A/D Sampling State Register | 0x0DF | 8 | R/W | 0x0D | 0xFF |
| ADC12 | 15 | 0x1 | 0-14 | ADSSTR%s | A/D Sampling State Register | 0x0E0 | 8 | R/W | 0x0D | 0xFF |
| DAC12 | — | — | — | DADR0 | D/A Data Register 0 | 0x00 | 16 | R/W | 0x0000 | 0xFFFF |
| DAC12 | — | — | — | DACR | D/A Control Register | 0x04 | 8 | R/W | 0x1F | 0xFF |
| DAC12 | — | — | — | DADPR | DADR0 Format Select Register | 0x05 | 8 | R/W | 0x00 | 0xFF |
| DAC12 | — | — | — | DAADSCR | D/A A/D Synchronous Start Control Register | 0x06 | 8 | R/W | 0x00 | 0xFF |
| DAC12 | — | — | — | DAVREFCR | D/A VREF Control Register | 0x07 | 8 | R/W | 0x00 | 0xFF |
| SCIO | — | — | — | SMR | Serial Mode Register for Non-Smart Card Interface Mode (SCMR.SMIF = 0) | 0x00 | 8 | R/W | 0x00 | 0xFF |
| SCIO | — | — | — | SMR_SMC1 | Serial Mode Register for Smart Card Interface Mode (SCMR.SMIF = 1) | 0x00 | 8 | R/W | 0x00 | 0xFF |
| SCIO | — | — | — | BRR | Bit Rate Register | 0x01 | 8 | R/W | 0xFF | 0xFF |
| SCIO | — | — | — | SCR | Serial Control Register for Non-Smart Card Interface Mode (SCMR.SMIF = 0) | 0x02 | 8 | R/W | 0x00 | 0xFF |
| SCIO | — | — | — | SCR_SMC1 | Serial Control Register for Smart Card Interface Mode (SCMR.SMIF = 1) | 0x02 | 8 | R/W | 0x00 | 0xFF |
| SCIO | — | — | — | TDR | Transmit Data Register | 0x03 | 8 | R/W | 0xFF | 0xFF |
| SCIO | — | — | — | SSR | Serial Status Register for Non-Smart Card Interface and Non-FIFO Mode (SCMR.SMIF = 0 and FCR.FM = 0) | 0x04 | 8 | R/W | 0x84 | 0xFF |
| SCIO | — | — | — | SSR_FIFO | Serial Status Register for Non-Smart Card Interface and FIFO Mode (SCMR.SMIF = 0 and FCR.FM = 1) | 0x04 | 8 | R/W | 0x80 | 0xFD |
| SCIO | — | — | — | SSR_SMC1 | Serial Status Register for Smart Card Interface Mode (SCMR.SMIF = 1) | 0x04 | 8 | R/W | 0x84 | 0xFF |
| SCIO | — | — | — | RDR | Receive Data Register | 0x05 | 8 | R/W | 0x00 | 0xFF |
| SCIO | — | — | — | SCMR | Smart Card Mode Register | 0x06 | 8 | R/W | 0xF2 | 0xFF |
| SCIO | — | — | — | SEMR | Serial Extended Mode Register | 0x07 | 8 | R/W | 0x00 | 0xFF |
| SCIO | — | — | — | SNFR | Noise Filter Setting Register | 0x08 | 8 | R/W | 0x00 | 0xFF |
| SCIO | — | — | — | SIMR1 | IIC Mode Register 1 | 0x09 | 8 | R/W | 0x00 | 0xFF |
| SCIO | — | — | — | SIMR2 | IIC Mode Register 2 | 0x0A | 8 | R/W | 0x00 | 0xFF |
| SCIO | — | — | — | SIMR3 | IIC Mode Register 3 | 0x0B | 8 | R/W | 0x00 | 0xFF |
| SCIO | — | — | — | SISR | IIC Status Register | 0x0C | 8 | R | 0x00 | 0xCB |

Table 3.4 Register description (10 of 15)

| Peripheral name | Dim | Dim inc. | Dim index | Register name | Description | Address offset | Size | R/W | Reset value | Reset mask |
|-----------------|-----|----------|-----------|---------------|--|----------------|------|-----|-------------|------------|
| SCI0 | — | — | — | SPMR | SPI Mode Register | 0x0D | 8 | R/W | 0x00 | 0xFF |
| SCI0 | — | — | — | TDRHL | Transmit Data Register | 0x0E | 16 | R/W | 0xFFFF | 0xFFFF |
| SCI0 | — | — | — | FRDRHL | Receive FIFO Data Register | 0x10 | 16 | R | 0x0000 | 0xFFFF |
| SCI0 | — | — | — | FTDRHL | Transmit FIFO Data Register | 0x0E | 16 | W | 0xFFFF | 0xFFFF |
| SCI0 | — | — | — | RDRHL | Receive Data Register | 0x10 | 16 | R | 0x0000 | 0xFFFF |
| SCI0 | — | — | — | FRDRH | Receive FIFO Data Register | 0x10 | 8 | R | 0x00 | 0xFF |
| SCI0 | — | — | — | FTDRH | Transmit FIFO Data Register | 0x0E | 8 | W | 0xFF | 0xFF |
| SCI0 | — | — | — | FRDRL | Receive FIFO Data Register | 0x11 | 8 | R | 0x00 | 0xFF |
| SCI0 | — | — | — | FTDRL | Transmit FIFO Data Register | 0x0F | 8 | W | 0xFF | 0xFF |
| SCI0 | — | — | — | MDDR | Modulation Duty Register | 0x12 | 8 | R/W | 0xFF | 0xFF |
| SCI0 | — | — | — | DCCR | Data Compare Match Control Register | 0x13 | 8 | R/W | 0x40 | 0xFF |
| SCI0 | — | — | — | FCR | FIFO Control Register | 0x14 | 16 | R/W | 0xF800 | 0xFFFF |
| SCI0 | — | — | — | FDR | FIFO Data Count Register | 0x16 | 16 | R | 0x0000 | 0xFFFF |
| SCI0 | — | — | — | LSR | Line Status Register | 0x18 | 16 | R | 0x0000 | 0xFFFF |
| SCI0 | — | — | — | CDR | Compare Match Data Register | 0x1A | 16 | R/W | 0x0000 | 0xFFFF |
| SCI0 | — | — | — | SPTR | Serial Port Register | 0x1C | 8 | R/W | 0x03 | 0xFF |
| SCI1-3,9 | — | — | — | SMR | Serial Mode Register for Non-Smart Card Interface Mode (SCMR.SMIF = 0) | 0x00 | 8 | R/W | 0x00 | 0xFF |
| SCI1-3,9 | — | — | — | SMR_SMCI | Serial Mode Register for Smart Card Interface Mode (SCMR.SMIF = 1) | 0x00 | 8 | R/W | 0x00 | 0xFF |
| SCI1-3,9 | — | — | — | BRR | Bit Rate Register | 0x01 | 8 | R/W | 0xFF | 0xFF |
| SCI1-3,9 | — | — | — | SCR | Serial Control Register for Non-Smart Card Interface Mode (SCMR.SMIF = 0) | 0x02 | 8 | R/W | 0x00 | 0xFF |
| SCI1-3,9 | — | — | — | SCR_SMCI | Serial Control Register for Smart Card Interface Mode (SCMR.SMIF = 1) | 0x02 | 8 | R/W | 0x00 | 0xFF |
| SCI1-3,9 | — | — | — | TDR | Transmit Data Register | 0x03 | 8 | R/W | 0xFF | 0xFF |
| SCI1-3,9 | — | — | — | SSR | Serial Status Register for Non-Smart Card Interface and Non-FIFO Mode (SCMR.SMIF = 0 and FCR.FM = 0) | 0x04 | 8 | R/W | 0x84 | 0xFF |
| SCI1-3,9 | — | — | — | SSR_SMCI | Serial Status Register for Smart Card Interface Mode (SCMR.SMIF = 1) | 0x04 | 8 | R/W | 0x84 | 0xFF |
| SCI1-3,9 | — | — | — | RDR | Receive Data Register | 0x05 | 8 | R/W | 0x00 | 0xFF |
| SCI1-3,9 | — | — | — | SCMR | Smart Card Mode Register | 0x06 | 8 | R/W | 0xF2 | 0xFF |
| SCI1-3,9 | — | — | — | SEMR | Serial Extended Mode Register | 0x07 | 8 | R/W | 0x00 | 0xFF |
| SCI1-3,9 | — | — | — | SNFR | Noise Filter Setting Register | 0x08 | 8 | R/W | 0x00 | 0xFF |
| SCI1-3,9 | — | — | — | SIMR1 | IIC Mode Register 1 | 0x09 | 8 | R/W | 0x00 | 0xFF |
| SCI1-3,9 | — | — | — | SIMR2 | IIC Mode Register 2 | 0x0A | 8 | R/W | 0x00 | 0xFF |
| SCI1-3,9 | — | — | — | SIMR3 | IIC Mode Register 3 | 0x0B | 8 | R/W | 0x00 | 0xFF |
| SCI1-3,9 | — | — | — | SISR | IIC Status Register | 0x0C | 8 | R | 0x00 | 0xCB |
| SCI1-3,9 | — | — | — | SPMR | SPI Mode Register | 0x0D | 8 | R/W | 0x00 | 0xFF |
| SCI1-3,9 | — | — | — | TDRHL | Transmit Data Register | 0x0E | 16 | R/W | 0xFFFF | 0xFFFF |
| SCI1-3,9 | — | — | — | RDRHL | Receive Data Register | 0x10 | 16 | R | 0x0000 | 0xFFFF |
| SCI1-3,9 | — | — | — | MDDR | Modulation Duty Register | 0x12 | 8 | R/W | 0xFF | 0xFF |
| SCI1-3,9 | — | — | — | DCCR | Data Compare Match Control Register | 0x13 | 8 | R/W | 0x40 | 0xFF |
| SCI1-3,9 | — | — | — | CDR | Compare Match Data Register | 0x1A | 16 | R/W | 0x0000 | 0xFFFF |
| SCI1-3,9 | — | — | — | SPTR | Serial Port Register | 0x1C | 8 | R/W | 0x03 | 0xFF |
| SPI0-1 | — | — | — | SPCR | SPI Control Register | 0x00 | 8 | R/W | 0x00 | 0xFF |
| SPI0-1 | — | — | — | SSLP | SPI Slave Select Polarity Register | 0x01 | 8 | R/W | 0x00 | 0xFF |

Table 3.4 Register description (11 of 15)

| Peripheral name | Dim | Dim inc. | Dim index | Register name | Description | Address offset | Size | R/W | Reset value | Reset mask |
|-----------------|-----|----------|-----------|---------------|---|----------------|------|-----|-------------|------------|
| SPI0-1 | — | — | — | SPPCR | SPI Pin Control Register | 0x02 | 8 | R/W | 0x00 | 0xFF |
| SPI0-1 | — | — | — | SPSR | SPI Status Register | 0x03 | 8 | R/W | 0x20 | 0xFF |
| SPI0-1 | — | — | — | SPDR | SPI Data Register | 0x04 | 32 | R/W | 0x00000000 | 0xFFFFFFFF |
| SPI0-1 | — | — | — | SPDR_HA | SPI Data Register | 0x04 | 16 | R/W | 0x0000 | 0xFFFF |
| SPI0-1 | — | — | — | SPBR | SPI Bit Rate Register | 0x0A | 8 | R/W | 0xFF | 0xFF |
| SPI0-1 | — | — | — | SPDCR | SPI Data Control Register | 0x0B | 8 | R/W | 0x00 | 0xFF |
| SPI0-1 | — | — | — | SPCKD | SPI Clock Delay Register | 0x0C | 8 | R/W | 0x00 | 0xFF |
| SPI0-1 | — | — | — | SSLND | SPI Slave Select Negation Delay Register | 0x0D | 8 | R/W | 0x00 | 0xFF |
| SPI0-1 | — | — | — | SPND | SPI Next-Access Delay Register | 0x0E | 8 | R/W | 0x00 | 0xFF |
| SPI0-1 | — | — | — | SPCR2 | SPI Control Register 2 | 0x0F | 8 | R/W | 0x00 | 0xFF |
| SPI0-1 | — | — | — | SPCMD0 | SPI Command Register 0 | 0x10 | 16 | R/W | 0x070D | 0xFFFF |
| CRC | — | — | — | CRCCR0 | CRC Control Register 0 | 0x00 | 8 | R/W | 0x00 | 0xFF |
| CRC | — | — | — | CRCCR1 | CRC Control Register 1 | 0x01 | 8 | R/W | 0x00 | 0xFF |
| CRC | — | — | — | CRCDIR | CRC Data Input Register | 0x04 | 32 | R/W | 0x00000000 | 0xFFFFFFFF |
| CRC | — | — | — | CRCDIR_BY | CRC Data Input Register | 0x04 | 8 | R/W | 0x00 | 0xFF |
| CRC | — | — | — | CRCDOR | CRC Data Output Register | 0x08 | 32 | R/W | 0x00000000 | 0xFFFFFFFF |
| CRC | — | — | — | CRCDOR_HA | CRC Data Output Register | 0x08 | 16 | R/W | 0x0000 | 0xFFFF |
| CRC | — | — | — | CRCDOR_BY | CRC Data Output Register | 0x08 | 8 | R/W | 0x00 | 0xFF |
| CRC | — | — | — | CRCSAR | Snoop Address Register | 0x0C | 16 | R/W | 0x0000 | 0xFFFF |
| GPT320-3 | — | — | — | GTWP | General PWM Timer Write-Protection Register | 0x00 | 32 | R/W | 0x00000000 | 0xFFFFFFFF |
| GPT320-3 | — | — | — | GTSTR | General PWM Timer Software Start Register | 0x04 | 32 | R/W | 0x00000000 | 0xFFFFFFFF |
| GPT320-3 | — | — | — | GTSTP | General PWM Timer Software Stop Register | 0x08 | 32 | R/W | 0xFFFFFFFF | 0xFFFFFFFF |
| GPT320-3 | — | — | — | GTCLR | General PWM Timer Software Clear Register | 0x0C | 32 | W | 0x00000000 | 0xFFFFFFFF |
| GPT320-3 | — | — | — | GTSSR | General PWM Timer Start Source Select Register | 0x10 | 32 | R/W | 0x00000000 | 0xFFFFFFFF |
| GPT320-3 | — | — | — | GTSPSR | General PWM Timer Stop Source Select Register | 0x14 | 32 | R/W | 0x00000000 | 0xFFFFFFFF |
| GPT320-3 | — | — | — | GTCSR | General PWM Timer Clear Source Select Register | 0x18 | 32 | R/W | 0x00000000 | 0xFFFFFFFF |
| GPT320-3 | — | — | — | GTUPSR | General PWM Timer Up Count Source Select Register | 0x1C | 32 | R/W | 0x00000000 | 0xFFFFFFFF |
| GPT320-3 | — | — | — | GTDNSR | General PWM Timer Down Count Source Select Register | 0x20 | 32 | R/W | 0x00000000 | 0xFFFFFFFF |
| GPT320-3 | — | — | — | GTICASR | General PWM Timer Input Capture Source Select Register A | 0x24 | 32 | R/W | 0x00000000 | 0xFFFFFFFF |
| GPT320-3 | — | — | — | GTICBSR | General PWM Timer Input Capture Source Select Register B | 0x28 | 32 | R/W | 0x00000000 | 0xFFFFFFFF |
| GPT320-3 | — | — | — | GTCR | General PWM Timer Control Register | 0x2C | 32 | R/W | 0x00000000 | 0xFFFFFFFF |
| GPT320-3 | — | — | — | GTUDDTYC | General PWM Timer Count Direction and Duty Setting Register | 0x30 | 32 | R/W | 0x00000001 | 0xFFFFFFFF |
| GPT320-3 | — | — | — | GTIOR | General PWM Timer I/O Control Register | 0x34 | 32 | R/W | 0x00000000 | 0xFFFFFFFF |
| GPT320-3 | — | — | — | GTINTAD | General PWM Timer Interrupt Output Setting Register | 0x38 | 32 | R/W | 0x00000000 | 0xFFFFFFFF |
| GPT320-3 | — | — | — | GTST | General PWM Timer Status Register | 0x3C | 32 | R/W | 0x00008000 | 0xFFFFFFFF |
| GPT320-3 | — | — | — | GTBER | General PWM Timer Buffer Enable Register | 0x40 | 32 | R/W | 0x00000000 | 0xFFFFFFFF |
| GPT320-3 | — | — | — | GTCNT | General PWM Timer Counter | 0x48 | 32 | R/W | 0x00000000 | 0xFFFFFFFF |

Table 3.4 Register description (12 of 15)

| Peripheral name | Dim | Dim inc. | Dim index | Register name | Description | Address offset | Size | R/W | Reset value | Reset mask |
|-----------------|-----|----------|-----------|---------------|---|----------------|------|-----|-------------|------------|
| GPT320-3 | — | — | — | GTCCRA | General PWM Timer Compare Capture Register A | 0x4C | 32 | R/W | 0xFFFFFFFF | 0xFFFFFFFF |
| GPT320-3 | — | — | — | GTCCRB | General PWM Timer Compare Capture Register B | 0x50 | 32 | R/W | 0xFFFFFFFF | 0xFFFFFFFF |
| GPT320-3 | — | — | — | GTCCRC | General PWM Timer Compare Capture Register C | 0x54 | 32 | R/W | 0xFFFFFFFF | 0xFFFFFFFF |
| GPT320-3 | — | — | — | GTCCRE | General PWM Timer Compare Capture Register E | 0x58 | 32 | R/W | 0xFFFFFFFF | 0xFFFFFFFF |
| GPT320-3 | — | — | — | GTCCRD | General PWM Timer Compare Capture Register D | 0x5C | 32 | R/W | 0xFFFFFFFF | 0xFFFFFFFF |
| GPT320-3 | — | — | — | GTCCRF | General PWM Timer Compare Capture Register F | 0x60 | 32 | R/W | 0xFFFFFFFF | 0xFFFFFFFF |
| GPT320-3 | — | — | — | GTPR | General PWM Timer Cycle Setting Register | 0x64 | 32 | R/W | 0xFFFFFFFF | 0xFFFFFFFF |
| GPT320-3 | — | — | — | GTPBR | General PWM Timer Cycle Setting Buffer Register | 0x68 | 32 | R/W | 0xFFFFFFFF | 0xFFFFFFFF |
| GPT320-3 | — | — | — | GTDTCR | General PWM Timer Dead Time Control Register | 0x88 | 32 | R/W | 0x00000000 | 0xFFFFFFFF |
| GPT320-3 | — | — | — | GTDVU | General PWM Timer Dead Time Value Register U | 0x8C | 32 | R/W | 0xFFFFFFFF | 0xFFFFFFFF |
| GPT164-9 | — | — | — | GTWP | General PWM Timer Write-Protection Register | 0x00 | 32 | R/W | 0x00000000 | 0xFFFFFFFF |
| GPT164-9 | — | — | — | GTSTR | General PWM Timer Software Start Register | 0x04 | 32 | R/W | 0x00000000 | 0xFFFFFFFF |
| GPT164-9 | — | — | — | GTSTP | General PWM Timer Software Stop Register | 0x08 | 32 | R/W | 0xFFFFFFFF | 0xFFFFFFFF |
| GPT164-9 | — | — | — | GTCLR | General PWM Timer Software Clear Register | 0x0C | 32 | W | 0x00000000 | 0xFFFFFFFF |
| GPT164-9 | — | — | — | GTSSR | General PWM Timer Start Source Select Register | 0x10 | 32 | R/W | 0x00000000 | 0xFFFFFFFF |
| GPT164-9 | — | — | — | GTSPSR | General PWM Timer Stop Source Select Register | 0x14 | 32 | R/W | 0x00000000 | 0xFFFFFFFF |
| GPT164-9 | — | — | — | GTCSR | General PWM Timer Clear Source Select Register | 0x18 | 32 | R/W | 0x00000000 | 0xFFFFFFFF |
| GPT164-9 | — | — | — | GTUPSR | General PWM Timer Up Count Source Select Register | 0x1C | 32 | R/W | 0x00000000 | 0xFFFFFFFF |
| GPT164-9 | — | — | — | GTDNSR | General PWM Timer Down Count Source Select Register | 0x20 | 32 | R/W | 0x00000000 | 0xFFFFFFFF |
| GPT164-9 | — | — | — | GTICASR | General PWM Timer Input Capture Source Select Register A | 0x24 | 32 | R/W | 0x00000000 | 0xFFFFFFFF |
| GPT164-9 | — | — | — | GTICBSR | General PWM Timer Input Capture Source Select Register B | 0x28 | 32 | R/W | 0x00000000 | 0xFFFFFFFF |
| GPT164-9 | — | — | — | GTCR | General PWM Timer Control Register | 0x2C | 32 | R/W | 0x00000000 | 0xFFFFFFFF |
| GPT164-9 | — | — | — | GTUDDTYC | General PWM Timer Count Direction and Duty Setting Register | 0x30 | 32 | R/W | 0x00000001 | 0xFFFFFFFF |
| GPT164-9 | — | — | — | GTIOR | General PWM Timer I/O Control Register | 0x34 | 32 | R/W | 0x00000000 | 0xFFFFFFFF |
| GPT164-9 | — | — | — | GTINTAD | General PWM Timer Interrupt Output Setting Register | 0x38 | 32 | R/W | 0x00000000 | 0xFFFFFFFF |
| GPT164-9 | — | — | — | GTST | General PWM Timer Status Register | 0x3C | 32 | R/W | 0x00008000 | 0xFFFFFFFF |
| GPT164-9 | — | — | — | GTBER | General PWM Timer Buffer Enable Register | 0x40 | 32 | R/W | 0x00000000 | 0xFFFFFFFF |
| GPT164-9 | — | — | — | GTCNT | General PWM Timer Counter | 0x48 | 32 | R/W | 0x00000000 | 0xFFFFFFFF |
| GPT164-9 | — | — | — | GTCCRA | General PWM Timer Compare Capture Register A | 0x4C | 32 | R/W | 0xFFFFFFFF | 0xFFFFFFFF |
| GPT164-9 | — | — | — | GTCCRB | General PWM Timer Compare Capture Register B | 0x50 | 32 | R/W | 0xFFFFFFFF | 0xFFFFFFFF |

Table 3.4 Register description (13 of 15)

| Peripheral name | Dim | Dim inc. | Dim index | Register name | Description | Address offset | Size | R/W | Reset value | Reset mask |
|-----------------|-----|----------|-----------|---------------|---|----------------|------|-----|-------------|------------|
| GPT164-9 | — | — | — | GTCCRC | General PWM Timer Compare Capture Register C | 0x54 | 32 | R/W | 0xFFFFFFFF | 0xFFFFFFFF |
| GPT164-9 | — | — | — | GTCCRE | General PWM Timer Compare Capture Register E | 0x58 | 32 | R/W | 0xFFFFFFFF | 0xFFFFFFFF |
| GPT164-9 | — | — | — | GTCCRD | General PWM Timer Compare Capture Register D | 0x5C | 32 | R/W | 0xFFFFFFFF | 0xFFFFFFFF |
| GPT164-9 | — | — | — | GTCCRF | General PWM Timer Compare Capture Register F | 0x60 | 32 | R/W | 0xFFFFFFFF | 0xFFFFFFFF |
| GPT164-9 | — | — | — | GTPR | General PWM Timer Cycle Setting Register | 0x64 | 32 | R/W | 0xFFFFFFFF | 0xFFFFFFFF |
| GPT164-9 | — | — | — | GTPBR | General PWM Timer Cycle Setting Buffer Register | 0x68 | 32 | R/W | 0xFFFFFFFF | 0xFFFFFFFF |
| GPT164-9 | — | — | — | GTDTCR | General PWM Timer Dead Time Control Register | 0x88 | 32 | R/W | 0x00000000 | 0xFFFFFFFF |
| GPT164-9 | — | — | — | GTDVU | General PWM Timer Dead Time Value Register U | 0x8C | 32 | R/W | 0xFFFFFFFF | 0xFFFFFFFF |
| GPT_OPS | — | — | — | OPSCR | Output Phase Switching Control Register | 0x00 | 32 | R/W | 0x00000000 | 0xFFFFFFFF |
| KINT | — | — | — | KRCTL | Key Return Control Register | 0x00 | 8 | R/W | 0x00 | 0xFF |
| KINT | — | — | — | KRF | Key Return Flag Register | 0x04 | 8 | R/W | 0x00 | 0xFF |
| KINT | — | — | — | KRM | Key Return Mode Register | 0x08 | 8 | R/W | 0x00 | 0xFF |
| CTSU | — | — | — | CTSUCRA | CTSU Control Register A | 0x00 | 32 | R/W | 0x00000000 | 0xFFFFFFFF |
| CTSU | — | — | — | CTSUCRAL | CTSU Control Register A | 0x00 | 16 | R/W | 0x0000 | 0xFFFF |
| CTSU | — | — | — | CTSUCR0 | CTSU Control Register A | 0x00 | 8 | R/W | 0x00 | 0xFF |
| CTSU | — | — | — | CTSUCR1 | CTSU Control Register A | 0x01 | 8 | R/W | 0x00 | 0xFF |
| CTSU | — | — | — | CTSUCR2 | CTSU Control Register A | 0x02 | 8 | R/W | 0x00 | 0xFF |
| CTSU | — | — | — | CTSUCR3 | CTSU Control Register A | 0x03 | 8 | R/W | 0x00 | 0xFF |
| CTSU | — | — | — | CTSUCRB | CTSU Control Register B | 0x04 | 32 | R/W | 0x00000000 | 0xFFFFFFFF |
| CTSU | — | — | — | CTSUCRBL | CTSU Control Register B | 0x04 | 16 | R/W | 0x0000 | 0xFFFF |
| CTSU | — | — | — | CTSUSDPRS | CTSU Control Register B | 0x04 | 8 | R/W | 0x00 | 0xFF |
| CTSU | — | — | — | CTSUSST | CTSU Control Register B | 0x05 | 8 | R/W | 0x00 | 0xFF |
| CTSU | — | — | — | CTSUCRBH | CTSU Control Register B | 0x06 | 16 | R/W | 0x0000 | 0xFFFF |
| CTSU | — | — | — | CTSUDCLKC | CTSU Control Register B | 0x07 | 8 | R/W | 0x00 | 0xFF |
| CTSU | — | — | — | CTSUMCH | CTSU Measurement Channel Register | 0x08 | 32 | R/W | 0x00003F3F | 0xFFFFFFFF |
| CTSU | — | — | — | CTSUMCHL | CTSU Measurement Channel Register | 0x08 | 16 | R/W | 0x0000 | 0xFFFF |
| CTSU | — | — | — | CTSUMCH0 | CTSU Measurement Channel Register | 0x08 | 8 | R/W | 0x00 | 0xFF |
| CTSU | — | — | — | CTSUMCH1 | CTSU Measurement Channel Register | 0x09 | 8 | R/W | 0x00 | 0xFF |
| CTSU | — | — | — | CTSUMCHH | CTSU Measurement Channel Register | 0x0A | 16 | R/W | 0x3F3F | 0xFFFF |
| CTSU | — | — | — | CTSUMFAF | CTSU Measurement Channel Register | 0x0A | 8 | R/W | 0x3F | 0xFF |
| CTSU | — | — | — | CTSUCHACA | CTSU Channel Enable Control Register A | 0x0C | 32 | R/W | 0x00000000 | 0xFFFFFFFF |
| CTSU | — | — | — | CTSUCHACAL | CTSU Channel Enable Control Register A | 0x0C | 16 | R/W | 0x0000 | 0xFFFF |
| CTSU | — | — | — | CTSUCHAC0 | CTSU Channel Enable Control Register A | 0x0C | 8 | R/W | 0x00 | 0xFF |
| CTSU | — | — | — | CTSUCHAC1 | CTSU Channel Enable Control Register A | 0x0D | 8 | R/W | 0x00 | 0xFF |
| CTSU | — | — | — | CTSUCHACAH | CTSU Channel Enable Control Register A | 0x0E | 16 | R/W | 0x0000 | 0xFFFF |
| CTSU | — | — | — | CTSUCHAC2 | CTSU Channel Enable Control Register A | 0x0E | 8 | R/W | 0x00 | 0xFF |
| CTSU | — | — | — | CTSUCHAC3 | CTSU Channel Enable Control Register A | 0x0F | 8 | R/W | 0x00 | 0xFF |
| CTSU | — | — | — | CTSUCHACB | CTSU Channel Enable Control Register B | 0x10 | 32 | R/W | 0x00000000 | 0xFFFFFFFF |
| CTSU | — | — | — | CTSUCHACBL | CTSU Channel Enable Control Register B | 0x10 | 16 | R/W | 0x0000 | 0xFFFF |
| CTSU | — | — | — | CTSUCHAC4 | CTSU Channel Enable Control Register B | 0x10 | 8 | R/W | 0x00 | 0xFF |

Table 3.4 Register description (14 of 15)

| Peripheral name | Dim | Dim inc. | Dim index | Register name | Description | Address offset | Size | R/W | Reset value | Reset mask |
|-----------------|-----|----------|-----------|---------------|--|----------------|------|-----|-------------|------------|
| CTSU | — | — | — | CTSUCHTRCA | CTSU Channel Transmit/Receive Control Register A | 0x14 | 32 | R/W | 0x00000000 | 0xFFFFFFFF |
| CTSU | — | — | — | CTSUCHTRCAL | CTSU Channel Transmit/Receive Control Register A | 0x14 | 16 | R/W | 0x0000 | 0xFFFF |
| CTSU | — | — | — | CTSUCHTRC0 | CTSU Channel Transmit/Receive Control Register A | 0x14 | 8 | R/W | 0x00 | 0xFF |
| CTSU | — | — | — | CTSUCHTRC1 | CTSU Channel Transmit/Receive Control Register A | 0x15 | 8 | R/W | 0x00 | 0xFF |
| CTSU | — | — | — | CTSUCHTRCAH | CTSU Channel Transmit/Receive Control Register A | 0x16 | 16 | R/W | 0x0000 | 0xFFFF |
| CTSU | — | — | — | CTSUCHTRC2 | CTSU Channel Transmit/Receive Control Register A | 0x16 | 8 | R/W | 0x00 | 0xFF |
| CTSU | — | — | — | CTSUCHTRC3 | CTSU Channel Transmit/Receive Control Register A | 0x17 | 8 | R/W | 0x00 | 0xFF |
| CTSU | — | — | — | CTSUCHTRCB | CTSU Channel Transmit/Receive Control Register B | 0x18 | 32 | R/W | 0x00000000 | 0xFFFFFFFF |
| CTSU | — | — | — | CTSUCHTRCBL | CTSU Channel Transmit/Receive Control Register B | 0x18 | 16 | R/W | 0x0000 | 0xFFFF |
| CTSU | — | — | — | CTSUCHTRC4 | CTSU Channel Transmit/Receive Control Register B | 0x18 | 8 | R/W | 0x00 | 0xFF |
| CTSU | — | — | — | CTSUSR | CTSU Status Register | 0x1C | 32 | R/W | 0x00000000 | 0xFFFFFFFF |
| CTSU | — | — | — | CTSUSRL | CTSU Status Register | 0x1C | 16 | R/W | 0x0000 | 0xFFFF |
| CTSU | — | — | — | CTSUSR0 | CTSU Status Register | 0x1C | 8 | R/W | 0x00 | 0xFF |
| CTSU | — | — | — | CTSUST | CTSU Status Register | 0x1D | 8 | R/W | 0x00 | 0xFF |
| CTSU | — | — | — | CTSUSRH | CTSU Status Register | 0x1E | 16 | R/W | 0x0000 | 0xFFFF |
| CTSU | — | — | — | CTSUSR2 | CTSU Status Register | 0x1E | 8 | R/W | 0x00 | 0xFF |
| CTSU | — | — | — | CTSUSO | CTSU Sensor Offset Register | 0x20 | 32 | R/W | 0x00000000 | 0xFFFFFFFF |
| CTSU | — | — | — | CTSUSO0 | CTSU Sensor Offset Register | 0x20 | 16 | R/W | 0x0000 | 0xFFFF |
| CTSU | — | — | — | CTSUSO1 | CTSU Sensor Offset Register | 0x22 | 16 | R/W | 0x0000 | 0xFFFF |
| CTSU | — | — | — | CTSUSCNT | CTSU Sensor Counter Register | 0x24 | 32 | R | 0x00000000 | 0xFFFFFFFF |
| CTSU | — | — | — | CTSUSC | CTSU Sensor Counter Register | 0x24 | 16 | R | 0x0000 | 0xFFFF |
| CTSU | — | — | — | CTSUCALIB | CTSU Calibration Register | 0x28 | 32 | R/W | 0x00000000 | 0xFFFFFFFF |
| CTSU | — | — | — | CTSUDBGR0 | CTSU Calibration Register | 0x28 | 16 | R/W | 0x0000 | 0xFFFF |
| CTSU | — | — | — | CTSUDBGR1 | CTSU Calibration Register | 0x2A | 16 | R/W | 0x0000 | 0xFFFF |
| CTSU | — | — | — | CTSUSUCLKA | CTSU Sensor Unit Clock Control Register A | 0x2C | 32 | R/W | 0x00000000 | 0xFFFFFFFF |
| CTSU | — | — | — | CTSUSUCLK0 | CTSU Sensor Unit Clock Control Register A | 0x2C | 16 | R/W | 0x0000 | 0xFFFF |
| CTSU | — | — | — | CTSUSUCLK1 | CTSU Sensor Unit Clock Control Register A | 0x2E | 16 | R/W | 0x0000 | 0xFFFF |
| CTSU | — | — | — | CTSUSUCLKB | CTSU Sensor Unit Clock Control Register B | 0x30 | 32 | R/W | 0x00000000 | 0xFFFFFFFF |
| CTSU | — | — | — | CTSUSUCLK2 | CTSU Sensor Unit Clock Control Register B | 0x30 | 16 | R/W | 0x0000 | 0xFFFF |
| CTSU | — | — | — | CTSUSUCLK3 | CTSU Sensor Unit Clock Control Register B | 0x32 | 16 | R/W | 0x0000 | 0xFFFF |
| CTSU | — | — | — | CTSUCFCNT | CTSU CFC Counter Register | 0x34 | 32 | R | 0x00000000 | 0xFFFFFFFF |
| CTSU | — | — | — | CTSUCFCNTL | CTSU CFC Counter Register | 0x34 | 16 | R | 0x0000 | 0xFFFF |
| AGT0-1 | — | — | — | AGT | AGT Counter Register | 0x00 | 16 | R/W | 0xFFFF | 0xFFFF |
| AGT0-1 | — | — | — | AGTCMB | AGT Compare Match B Register | 0x04 | 16 | R/W | 0xFFFF | 0xFFFF |
| AGT0-1 | — | — | — | AGTCMA | AGT Compare Match A Register | 0x02 | 16 | R/W | 0xFFFF | 0xFFFF |
| AGT0-1 | — | — | — | AGTCR | AGT Control Register | 0x08 | 8 | R/W | 0x00 | 0xFF |

Table 3.4 Register description (15 of 15)

| Peripheral name | Dim | Dim inc. | Dim index | Register name | Description | Address offset | Size | R/W | Reset value | Reset mask |
|-----------------|-----|----------|-----------|---------------|---|----------------|------|-----|-------------|------------|
| AGT0-1 | — | — | — | AGTMR1 | AGT Mode Register 1 | 0x09 | 8 | R/W | 0x00 | 0xFF |
| AGT0-1 | — | — | — | AGTMR2 | AGT Mode Register 2 | 0x0A | 8 | R/W | 0x00 | 0xFF |
| AGT0-1 | — | — | — | AGTIOC | AGT I/O Control Register | 0x0C | 8 | R/W | 0x00 | 0xFF |
| AGT0-1 | — | — | — | AGTISR | AGT Event Pin Select Register | 0x0D | 8 | R/W | 0x00 | 0xFF |
| AGT0-1 | — | — | — | AGTCMSR | AGT Compare Match Function Select Register | 0x0E | 8 | R/W | 0x00 | 0xFF |
| AGT0-1 | — | — | — | AGTIOSEL | AGT Pin Select Register | 0x00F | 8 | R/W | 0x00 | 0xFF |
| ACMPLP | — | — | — | COMPMDR | ACMPLP Mode Setting Register | 0x00 | 8 | R/W | 0x00 | 0xFF |
| ACMPLP | — | — | — | COMPFIR | ACMPLP Filter Control Register | 0x01 | 8 | R/W | 0x00 | 0xFF |
| ACMPLP | — | — | — | COMPOCR | ACMPLP Output Control Register | 0x02 | 8 | R/W | 0x00 | 0xFF |
| FLCN | — | — | — | DFLCTL | Data Flash Enable Register | 0x0090 | 8 | R/W | 0x00 | 0xFF |
| FLCN | — | — | — | TSCDR | Temperature Sensor Calibration Data Register | 0x0228 | 16 | R | 0x00 | 0x00 |
| FLCN | — | — | — | CTSUTRIMA | CTSU Trimming Register A | 0x03A4 | 32 | R/W | 0x00000000 | 0x00000000 |
| FLCN | — | — | — | FLDWAITR | Memory Wait Cycle Control Register for Data Flash | 0x3FC4 | 8 | R/W | 0x00 | 0xFF |
| FLCN | — | — | — | PFBER | Prefetch Buffer Enable Register | 0x3FC8 | 8 | R/W | 0x00 | 0xFF |

Note:

- Peripheral name = Name of peripheral
- Dim = Number of elements in an array of registers
- Dim inc. = Address increment between two simultaneous registers of a register array in the address map
- Dim index = Sub string that replaces the %s placeholder within the register name
- Register name = Name of register
- Description = Register description
- Address offset = Address of the register relative to the base address defined by the peripheral of the register
- Size = Bit width of the register
- Reset value = Default reset value of a register
- Reset mask = Identifies which register bits have a defined reset value

Revision History

Revision 1.00 — Aug 06, 2020

First edition, issued

Revision 1.10 — Feb 26, 2021

Features:

- Changed from LFQFP to LQFP.

Overview:

- Changed from LFQFP to LQFP in Figure 1.2 Part numbering scheme.
- Added PWQN0048KC-A to Table 1.11 Product list.
- Changed from MISO0_A to MISO9_A for P202 in Table 1.14 Pin list.

Electrical Characteristics:

- Added Note 5 to Table 2.19 Clock timing.

Appendix 2. Package Dimensions:

- Added Figure 2.5 HWQFN 48-pin.

Revision 1.20 — May 20, 2022

Overview:

- Added Table 1.11 I/O ports to 1.1 Function Outline.
- Fixed Figure 1.2 Part numbering scheme in 1.3 Part Numbering.
- Fixed Table 1.13 Function comparison in 1.4 Function Comparison.
- Added I/O ports to Table 1.13 Function comparison.
- Fixed Figure 1.7 Pin assignment for QFN 48-pin (top view) in 1.6 Pin Assignments.

Electrical Characteristics:

- Fixed Table 2.4 I/O V_{IH} , V_{IL} in 2.2.2 I/O V_{IH} , V_{IL} .
- Fixed Table 2.11 Operating and standby current (2) in 2.2.5 Operating and Standby Current.
- Fixed Note 2 in Table 2.47 Power-on reset circuit and voltage detection circuit characteristics (1) in 2.8 POR and LVD Characteristics.

Revision 1.30 — November 30, 2022

1. Overview:

- Updated 1.3 Part Numbering.
- Updated Table 1.13 Function comparison.

2. Electrical Characteristics:

- Updated Table 2.32 SPI timing.
- Updated 2.11.1 Code Flash Memory Characteristics and 2.11.2 Data Flash Memory Characteristics.

Appendix 2. Package Dimensions:

- Updated the figure title of Figure 2.3 LQFP 64-pin (1).
- Added Figure 2.4 LQFP 64-pin (2).
- Updated the figure title of Figure 2.5 LQFP 48-pin (1).
- Added Figure 2.6 LQFP 48-pin (2).

Appendix 3. I/O Registers:

- Updated Table 3.2 Access cycles for non-GPT modules.
- Updated Table 3.4 Register description.

General Precautions in the Handling of Microprocessing Unit and Microcontroller Unit Products

The following usage notes are applicable to all Microprocessing unit and Microcontroller unit products from Renesas. For detailed usage notes on the products covered by this document, refer to the relevant sections of the document as well as any technical updates that have been issued for the products.

1. Precaution against Electrostatic Discharge (ESD)

A strong electrical field, when exposed to a CMOS device, can cause destruction of the gate oxide and ultimately degrade the device operation. Steps must be taken to stop the generation of static electricity as much as possible, and quickly dissipate it when it occurs. Environmental control must be adequate. When it is dry, a humidifier should be used. This is recommended to avoid using insulators that can easily build up static electricity.

Semiconductor devices must be stored and transported in an anti-static container, static shielding bag or conductive material. All test and measurement tools including work benches and floors must be grounded. The operator must also be grounded using a wrist strap. Semiconductor devices must not be touched with bare hands. Similar precautions must be taken for printed circuit boards with mounted semiconductor devices.

2. Processing at power-on

The state of the product is undefined at the time when power is supplied. The states of internal circuits in the LSI are indeterminate and the states of register settings and pins are undefined at the time when power is supplied. In a finished product where the reset signal is applied to the external reset pin, the states of pins are not guaranteed from the time when power is supplied until the reset process is completed. In a similar way, the states of pins in a product that is reset by an on-chip power-on reset function are not guaranteed from the time when power is supplied until the power reaches the level at which resetting is specified.

3. Input of signal during power-off state

Do not input signals or an I/O pull-up power supply while the device is powered off. The current injection that results from input of such a signal or I/O pull-up power supply may cause malfunction and the abnormal current that passes in the device at this time may cause degradation of internal elements. Follow the guideline for input signal during power-off state as described in your product documentation.

4. Handling of unused pins

Handle unused pins in accordance with the directions given under handling of unused pins in the manual. The input pins of CMOS products are generally in the high-impedance state. In operation with an unused pin in the open-circuit state, extra electromagnetic noise is induced in the vicinity of the LSI, an associated shoot-through current flows internally, and malfunctions occur due to the false recognition of the pin state as an input signal become possible.

5. Clock signals

After applying a reset, only release the reset line after the operating clock signal becomes stable. When switching the clock signal during program execution, wait until the target clock signal is stabilized. When the clock signal is generated with an external resonator or from an external oscillator during a reset, ensure that the reset line is only released after full stabilization of the clock signal. Additionally, when switching to a clock signal produced with an external resonator or by an external oscillator while program execution is in progress, wait until the target clock signal is stable.

6. Voltage application waveform at input pin

Waveform distortion due to input noise or a reflected wave may cause malfunction. If the input of the CMOS device stays in the area between V_{IL} (Max.) and V_{IH} (Min.) due to noise, for example, the device may malfunction. Take care to prevent chattering noise from entering the device when the input level is fixed, and also in the transition period when the input level passes through the area between V_{IL} (Max.) and V_{IH} (Min.).

7. Prohibition of access to reserved addresses

Access to reserved addresses is prohibited. The reserved addresses are provided for possible future expansion of functions. Do not access these addresses as the correct operation of the LSI is not guaranteed.

8. Differences between products

Before changing from one product to another, for example to a product with a different part number, confirm that the change will not lead to problems. The characteristics of a microprocessing unit or microcontroller unit products in the same group but having a different part number might differ in terms of internal memory capacity, layout pattern, and other factors, which can affect the ranges of electrical characteristics, such as characteristic values, operating margins, immunity to noise, and amount of radiated noise. When changing to a product with a different part number, implement a system-evaluation test for the given product.

Notice

1. Descriptions of circuits, software and other related information in this document are provided only to illustrate the operation of semiconductor products and application examples. You are fully responsible for the incorporation or any other use of the circuits, software, and information in the design of your product or system. Renesas Electronics disclaims any and all liability for any losses and damages incurred by you or third parties arising from the use of these circuits, software, or information.
2. Renesas Electronics hereby expressly disclaims any warranties against and liability for infringement or any other claims involving patents, copyrights, or other intellectual property rights of third parties, by or arising from the use of Renesas Electronics products or technical information described in this document, including but not limited to, the product data, drawings, charts, programs, algorithms, and application examples.
3. No license, express, implied or otherwise, is granted hereby under any patents, copyrights or other intellectual property rights of Renesas Electronics or others.
4. You shall be responsible for determining what licenses are required from any third parties, and obtaining such licenses for the lawful import, export, manufacture, sales, utilization, distribution or other disposal of any products incorporating Renesas Electronics products, if required.
5. You shall not alter, modify, copy, or reverse engineer any Renesas Electronics product, whether in whole or in part. Renesas Electronics disclaims any and all liability for any losses or damages incurred by you or third parties arising from such alteration, modification, copying or reverse engineering.
6. Renesas Electronics products are classified according to the following two quality grades: "Standard" and "High Quality". The intended applications for each Renesas Electronics product depends on the product's quality grade, as indicated below.
 - "Standard": Computers; office equipment; communications equipment; test and measurement equipment; audio and visual equipment; home electronic appliances; machine tools; personal electronic equipment; industrial robots; etc.
 - "High Quality": Transportation equipment (automobiles, trains, ships, etc.); traffic control (traffic lights); large-scale communication equipment; key financial terminal systems; safety control equipment; etc.Unless expressly designated as a high reliability product or a product for harsh environments in a Renesas Electronics data sheet or other Renesas Electronics document, Renesas Electronics products are not intended or authorized for use in products or systems that may pose a direct threat to human life or bodily injury (artificial life support devices or systems; surgical implantations; etc.), or may cause serious property damage (space system; undersea repeaters; nuclear power control systems; aircraft control systems; key plant systems; military equipment; etc.). Renesas Electronics disclaims any and all liability for any damages or losses incurred by you or any third parties arising from the use of any Renesas Electronics product that is inconsistent with any Renesas Electronics data sheet, user's manual or other Renesas Electronics document.
7. No semiconductor product is absolutely secure. Notwithstanding any security measures or features that may be implemented in Renesas Electronics hardware or software products, Renesas Electronics shall have absolutely no liability arising out of any vulnerability or security breach, including but not limited to any unauthorized access to or use of a Renesas Electronics product or a system that uses a Renesas Electronics product. RENESAS ELECTRONICS DOES NOT WARRANT OR GUARANTEE THAT RENESAS ELECTRONICS PRODUCTS, OR ANY SYSTEMS CREATED USING RENESAS ELECTRONICS PRODUCTS WILL BE INVULNERABLE OR FREE FROM CORRUPTION, ATTACK, VIRUSES, INTERFERENCE, HACKING, DATA LOSS OR THEFT, OR OTHER SECURITY INTRUSION ("Vulnerability Issues"). RENESAS ELECTRONICS DISCLAIMS ANY AND ALL RESPONSIBILITY OR LIABILITY ARISING FROM OR RELATED TO ANY VULNERABILITY ISSUES. FURTHERMORE, TO THE EXTENT PERMITTED BY APPLICABLE LAW, RENESAS ELECTRONICS DISCLAIMS ANY AND ALL WARRANTIES, EXPRESS OR IMPLIED, WITH RESPECT TO THIS DOCUMENT AND ANY RELATED OR ACCOMPANYING SOFTWARE OR HARDWARE, INCLUDING BUT NOT LIMITED TO THE IMPLIED WARRANTIES OF MERCHANTABILITY, OR FITNESS FOR A PARTICULAR PURPOSE.
8. When using Renesas Electronics products, refer to the latest product information (data sheets, user's manuals, application notes, "General Notes for Handling and Using Semiconductor Devices" in the reliability handbook, etc.), and ensure that usage conditions are within the ranges specified by Renesas Electronics with respect to maximum ratings, operating power supply voltage range, heat dissipation characteristics, installation, etc. Renesas Electronics disclaims any and all liability for any malfunctions, failure or accident arising out of the use of Renesas Electronics products outside of such specified ranges.
9. Although Renesas Electronics endeavors to improve the quality and reliability of Renesas Electronics products, semiconductor products have specific characteristics, such as the occurrence of failure at a certain rate and malfunctions under certain use conditions. Unless designated as a high reliability product or a product for harsh environments in a Renesas Electronics data sheet or other Renesas Electronics document, Renesas Electronics products are not subject to radiation resistance design. You are responsible for implementing safety measures to guard against the possibility of bodily injury, injury or damage caused by fire, and/or danger to the public in the event of a failure or malfunction of Renesas Electronics products, such as safety design for hardware and software, including but not limited to redundancy, fire control and malfunction prevention, appropriate treatment for aging degradation or any other appropriate measures. Because the evaluation of microcomputer software alone is very difficult and impractical, you are responsible for evaluating the safety of the final products or systems manufactured by you.
10. Please contact a Renesas Electronics sales office for details as to environmental matters such as the environmental compatibility of each Renesas Electronics product. You are responsible for carefully and sufficiently investigating applicable laws and regulations that regulate the inclusion or use of controlled substances, including without limitation, the EU RoHS Directive, and using Renesas Electronics products in compliance with all these applicable laws and regulations. Renesas Electronics disclaims any and all liability for damages or losses occurring as a result of your noncompliance with applicable laws and regulations.
11. Renesas Electronics products and technologies shall not be used for or incorporated into any products or systems whose manufacture, use, or sale is prohibited under any applicable domestic or foreign laws or regulations. You shall comply with any applicable export control laws and regulations promulgated and administered by the governments of any countries asserting jurisdiction over the parties or transactions.
12. It is the responsibility of the buyer or distributor of Renesas Electronics products, or any other party who distributes, disposes of, or otherwise sells or transfers the product to a third party, to notify such third party in advance of the contents and conditions set forth in this document.
13. This document shall not be reprinted, reproduced or duplicated in any form, in whole or in part, without prior written consent of Renesas Electronics.
14. Please contact a Renesas Electronics sales office if you have any questions regarding the information contained in this document or Renesas Electronics products.

(Note1) "Renesas Electronics" as used in this document means Renesas Electronics Corporation and also includes its directly or indirectly controlled subsidiaries.

(Note2) "Renesas Electronics product(s)" means any product developed or manufactured by or for Renesas Electronics.

(Rev.5.0-1 October 2020)

Corporate Headquarters

TOYOSU FORESIA, 3-2-24 Toyosu,
Koto-ku, Tokyo 135-0061, Japan
www.renesas.com

Trademarks

Renesas and the Renesas logo are trademarks of Renesas Electronics Corporation. All trademarks and registered trademarks are the property of their respective owners.

Contact Information

For further information on a product, technology, the most up-to-date version of a document, or your nearest sales office, please visit:
www.renesas.com/contact/

X-ON Electronics

Largest Supplier of Electrical and Electronic Components

Click to view similar products for [ARM Microcontrollers - MCU category](#):

Click to view products by [Renesas manufacturer](#):

Other Similar products are found below :

[R7FS3A77C2A01CLK#AC1](#) [R7FS7G27G2A01CLK#AC0](#) [R7FS7G27H2A01CLK#AC0](#) [MB96F119RBPMC-GSE1](#) [MB9BF122LPMC-G-JNE2](#) [MB9BF128SAPMC-GE2](#) [MB9BF529TBGL-GE1](#) [XMC4500-E144F1024 AC](#) [EFM32PG1B200F128GM48-C0](#) [CG8349AT](#)
[STM32F215ZET6TR](#) [26-21/R6C-AT1V2B/CT](#) [5962-8506403MQA](#) [STM32F769AIY6TR](#) [STM32L4R5ZIY6TR](#) [VA10800-D000003PCA](#)
[EFM32PG1B100F256GM32-C0](#) [EFM32PG1B200F256GM32-C0](#) [EFM32PG1B100F128GM32-C0](#) [STM32F779AIY6TR](#)
[MB9BF104NAPMC-G-JNE1](#) [CY8C4125FNI-S433T](#) [CY8C4247FNQ-BL483T](#) [CY8C4725LQI-S401](#) [K32L2A31VLH1A](#) [STM32G474PEI6](#)
[STM32G474PEI6TR](#) [MK26FN2M0CAC18R](#) [TM4C1231H6PMI7R](#) [S6J336CHTBSC20000](#) [STM32C011F4U6TR](#) [STM32C011F6P6](#)
[STM32C011F6U6TR](#) [STM32C031C6T6](#) [STM32C031F6P6](#) [STM32C031G6U6](#) [STM32F100CBT6](#) [STM32F401CCY6TR](#)
[STM32F413VGT6TR](#) [STM32H725AGI3](#) [STM32H725IGT3](#) [STM32L471RET3](#) [STM32MP133FAE7](#) [STM32U575VGT6](#) [STM32U575ZGT6](#)
[STM32WB10CCU5](#) [STM32WB15CCU6](#) [STM32WB35CEU6A](#) [STM32WB35CEU6ATR](#) [STR710RZH6](#)