

RNA51953A, B

R03DS0009EJ0500

Rev.5.00

Jun 19, 2012

Voltage Detecting, System Resetting IC Series

Description

RNA51953A,B are semiconductor integrated circuits designed for detecting supply voltage and resetting all types of logic circuits such as CPUs.

They include a built-in delay circuit to provide the desired retardation time simply by adding an external capacitor.

They find extensive applications, including battery checking circuit, level detecting circuit and waveform shaping circuit.

Features

- Few external parts
- Large delay time with a capacitor of small capacitance ($t_d \approx 100$ ms, at $0.33 \mu\text{F}$)
- Low threshold operating voltage (Supply voltage to keep low-state at low supply voltage):
0.6 V (Typ) at $R_L = 22 \text{ k}\Omega$
- Wide supply voltage range: 2 V to 17 V
- Wide application range
- Ordering Information

Part Name	Package Type	Package Code	Package Abbreviation	Taping Abbreviation (Quantity)	Surface Treatment
RNA51953AFPH0	SOP-8 pin	PRSP0008DE-C	FP	H (2,500 pcs / Reel)	0 (Ni/Pd/Au)
RNA51953APT0	DIP-8 pin	PRDP0008AF-B	P	T (1,000 pcs / Box)	0 (Ni/Pd/Au)
RNA51953BFPH0	SOP-8 pin	PRSP0008DE-C	FP	H (2,500 pcs / Reel)	0 (Ni/Pd/Au)
RNA51953BPT0	DIP-8 pin	PRDP0008AF-B	P	T (1,000 pcs / Box)	0 (Ni/Pd/Au)

Application

- Reset circuit of Pch, Nch, CMOS, microcomputer, CPU and MCU, Reset of logic circuit, Battery check circuit, switching circuit back-up voltage, level detecting circuit, waveform shaping circuit, delay waveform generating circuit, DC/DC converter, over voltage protection circuit

Recommended Operating Condition

- Supply voltage range: 2 V to 17 V

Outline and Article Indication

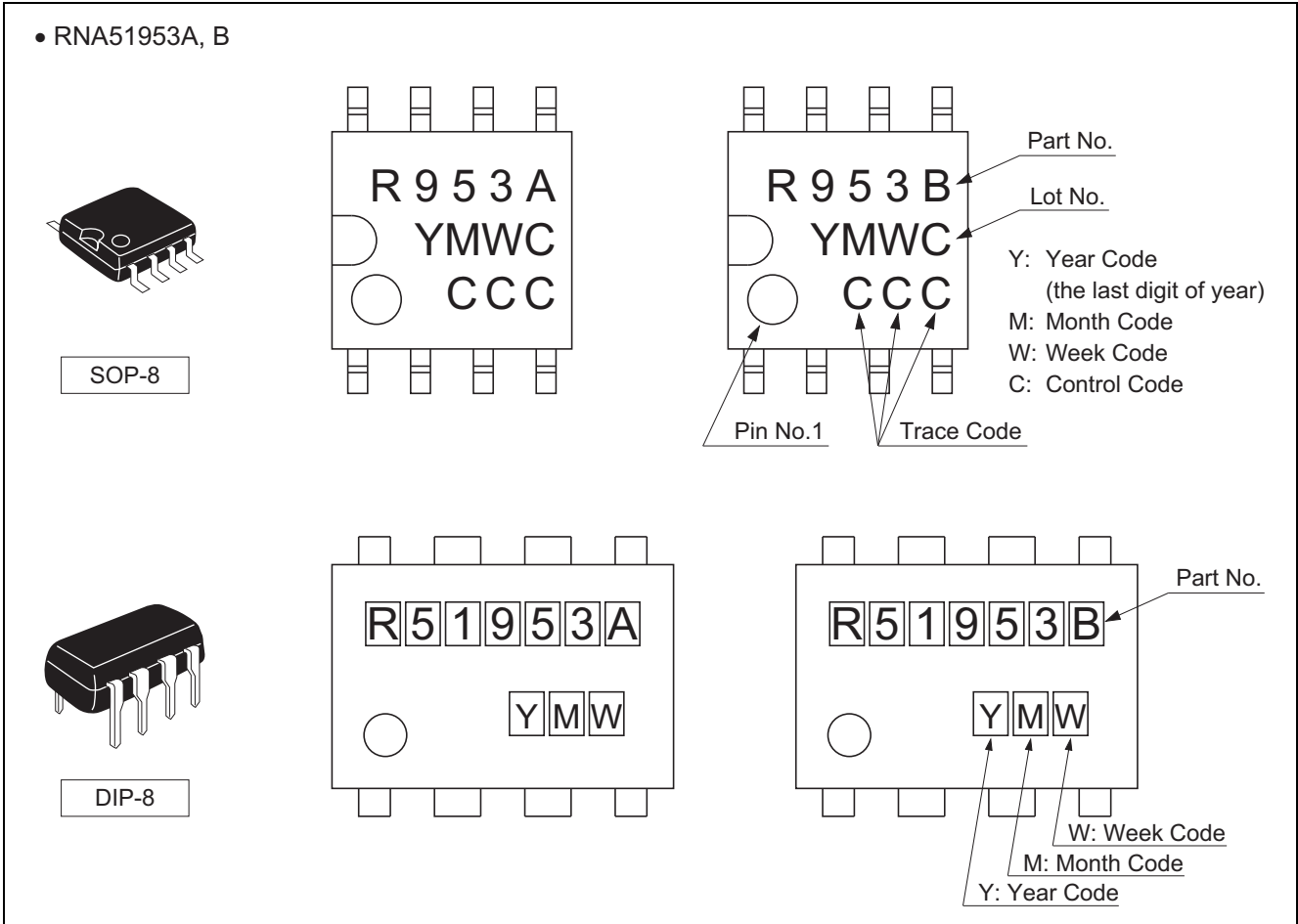

Pin Arrangement

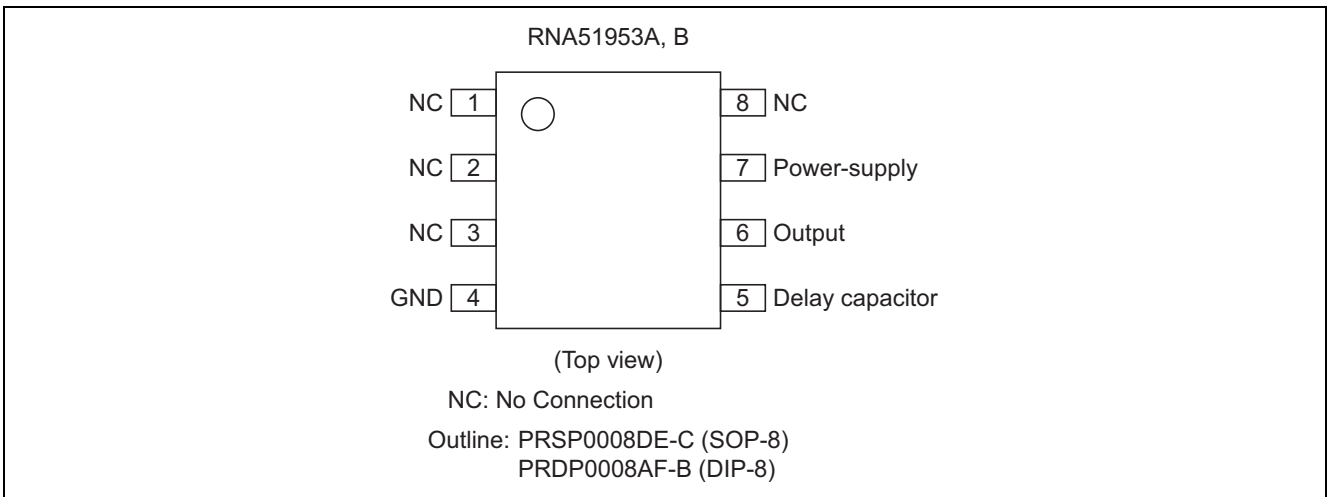

Block Diagram

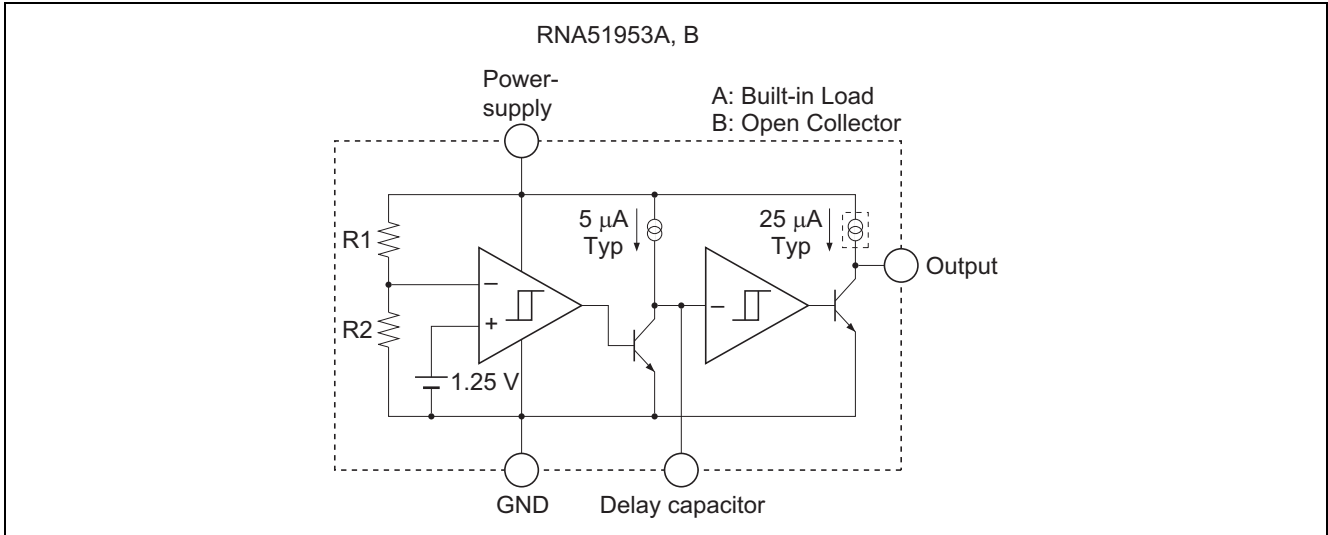

Operating Waveform

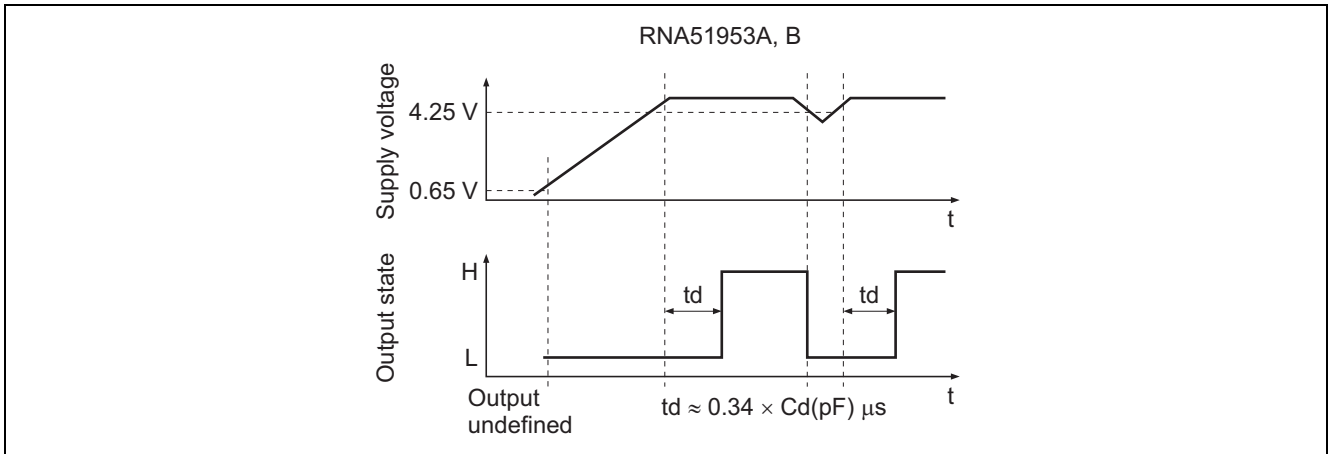

Absolute Maximum Ratings

(Ta = 25°C, unless otherwise noted)

Item	Symbol	Ratings	Unit	Conditions
Supply voltage	V _{CC}	18	V	
Output sink current	I _{sink}	6	mA	
Output voltage	V _O	V _{CC}	V	Type A (output with constant current load)
		18		Type B (open collector output)
Power dissipation	P _d	400	mW	8-pin SOP (PRSP0008DE-C)
		570		8-pin DIP (PRDP0008AF-B)
Thermal derating	K _θ	4.4	mW/°C	8-pin SOP (PRSP0008DE-C)
		8.3		8-pin DIP (PRDP0008AF-B)
Operating temperature	Topr	-40 to +85	°C	Refer to the thermal derating curve.
Storage temperature	Tstg	-55 to +125	°C	

Electrical Characteristics

(Ta = 25°C, unless otherwise noted)

- “L” reset type

Item	Symbol	Min	Typ	Max	Unit	Test Conditions
Detecting voltage	V _S	4.05	4.25	4.45	V	
Hysteresis voltage	ΔV _S	30	50	80	mV	
Detecting voltage temperature coefficient	V _S /ΔT	—	0.01	—	%/°C	
Circuit current	I _{CC}	—	450	680	μA	Type A, V _{CC} = 5V
		—	420	630		Type B, V _{CC} = 5V
Delay time	t _{pd}	1.6	3.4	7.0	ms	Cd = 0.01 μF *
Constant current	I _{pd}	-8	-5	-3	μA	V _{CC} = 5V
Output saturation voltage	V _{sat}	—	0.2	0.4	V	V _{CC} = 4V, I _{sink} = 4mA
Threshold operating voltage	V _{OPL}	—	0.67	0.8	V	R _L = 2.2kΩ, V _{sat} ≤ 0.4V
		—	0.55	0.7		R _L = 100kΩ, V _{sat} ≤ 0.4V
Output leakage current	I _{OH}	—	—	30	nA	Type B
Output load current	I _{OC}	-40	-25	-17	μA	Type A, V _{CC} = 5V, V _O = 1/2 × V _{CC}
Output high voltage	V _{OH}	V _{CC} -0.2	V _{CC} -0.06	—	V	Type A

Note: Please set the desired delay time by attaching capacitor of the range between 4700 pF and 10 μF.

Typical Characteristics

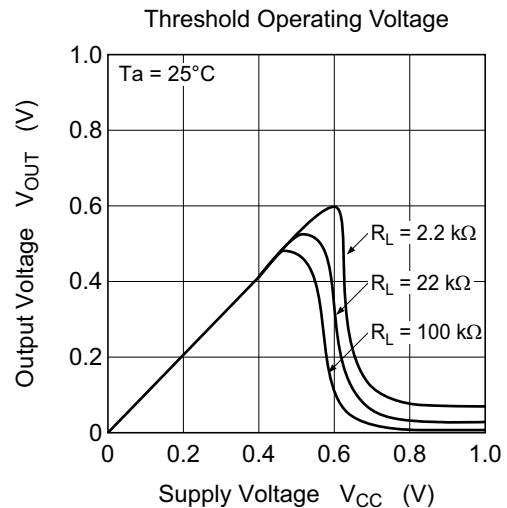
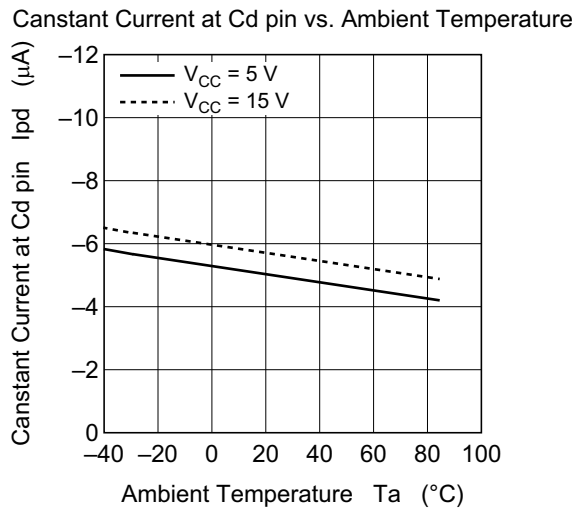
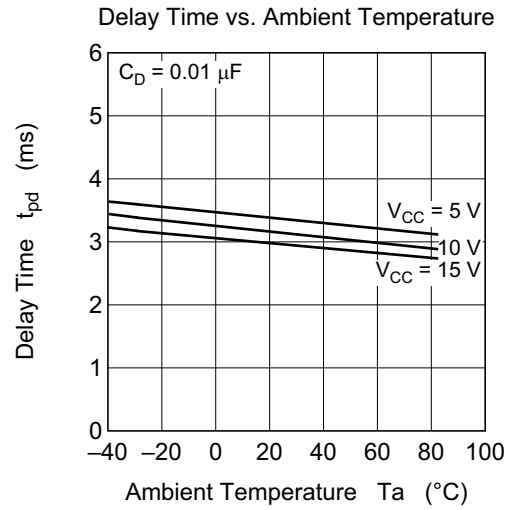
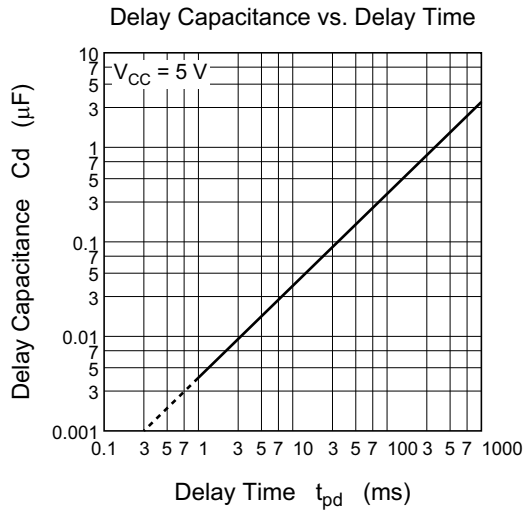
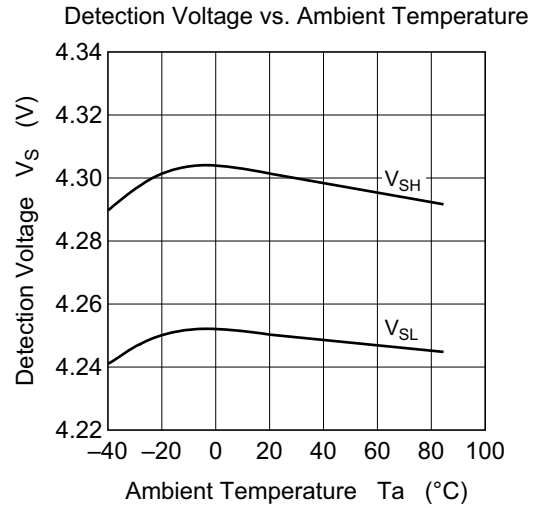
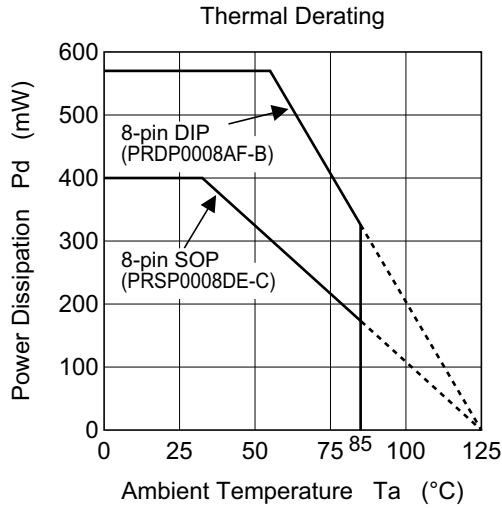

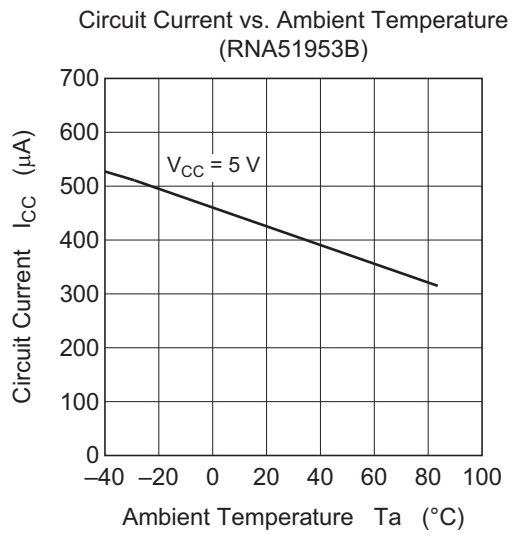
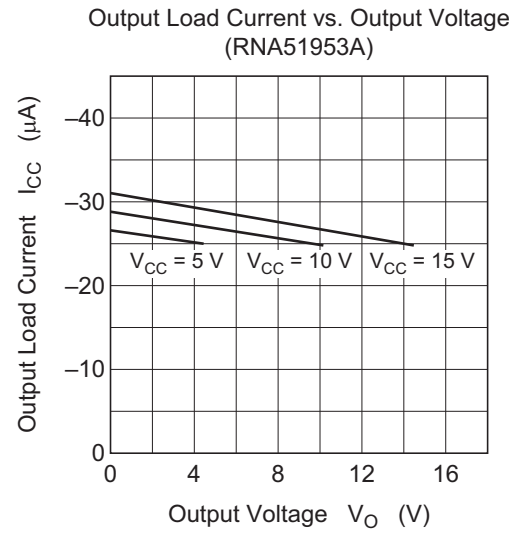
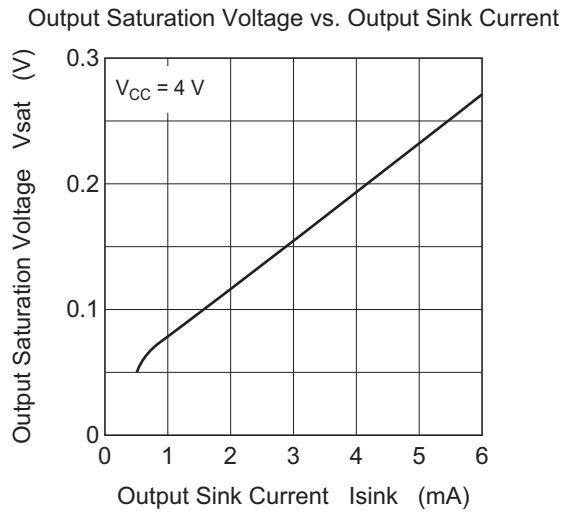

Example of Application Circuit

Reset Circuit of RNA51953

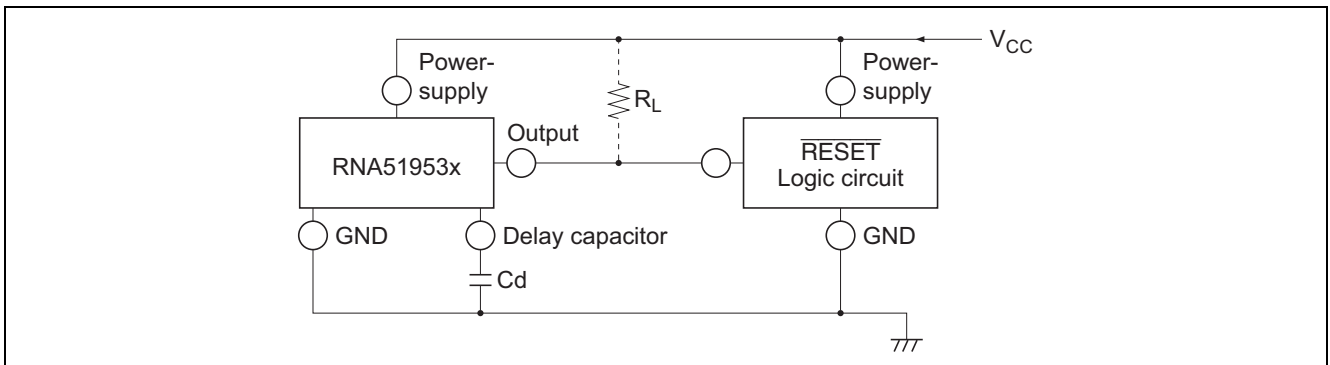

Figure 1 Reset Circuit of RNA51953

- Notes:
1. The delay time is about $0.34 \times C_d$ (pF) μ s.
 2. If the RNA51953 and the logic circuit share a common power source, type A (built-in load type) can be used whether a pull-up resistor is included in the logic circuit or not.
 3. The logic circuit preferably should not have a pull-down resistor, but if one is present, add load resistor R_L to overcome the pull-down resistor.
 4. When a negative supply voltage is used, the supply voltage side of RNA51953 and the GND side are connected to negative supply voltage respectively.

Case of Using Reset Signal except Supply Voltage in the RNA51953

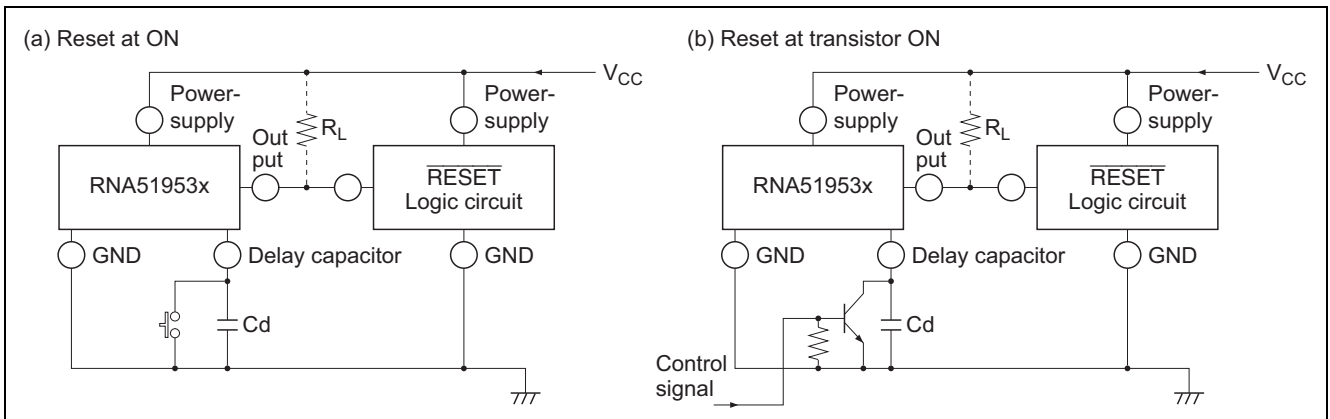

Figure 2 Case of Using Reset Signal except Supply Voltage in the RNA51953

Notice for use

About the Power Supply Line

1. About bypass capacitor

Because the ripple and the spike of the high frequency noise and the low frequency are superimposed to the power supply line, it is necessary to remove these.

Therefore, please install C_1 and C_2 for the low frequency and for the high frequency between the power supply line and the GND line as shown in following figure 3.

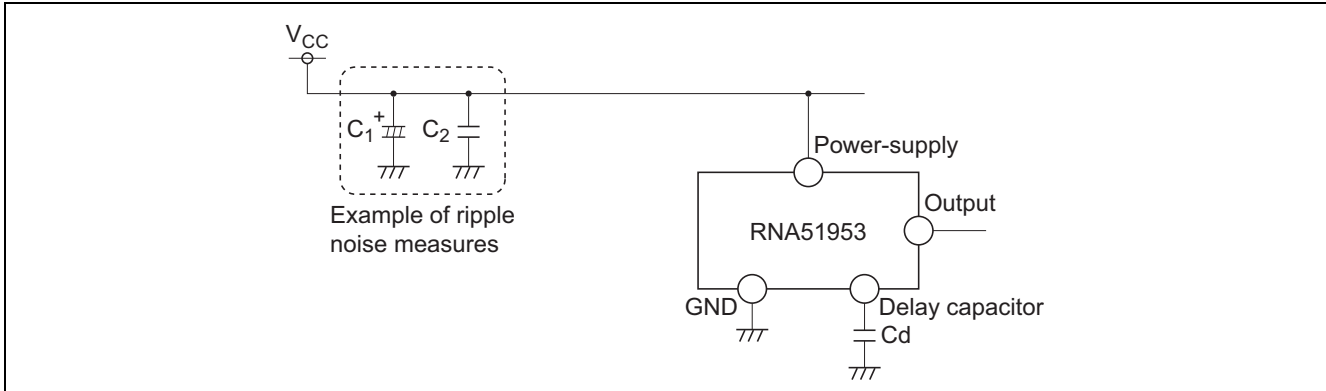

Figure 3 Example of Ripple Noise Measures

Setting of Delay Capacity

Please use capacitor C_d for the delay within the range of 10 μ F or less.

When a value that is bigger than this is set, the problem such as following (1), (2), and (3) becomes remarkable.

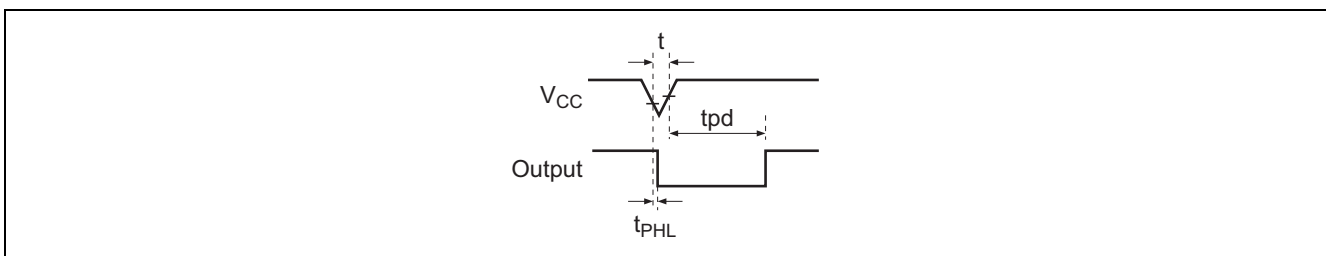

Figure 4 Time Chart at Momentary Voltage-Decrease

(1) The difference at delay time becomes remarkable.

A long delay setting of tens of seconds is fundamentally possible. However, when set delay time is lengthened, the range of the difference relatively grows, too. When a set value is assumed to be 'tpd', the difference occurs in the range from $0.47 \times t_{pd}$ to $2.05 \times t_{pd}$. For instance, 34 seconds can be calculated at 100 μ F. However, it is likely to vary within the ranges of 16-70 seconds.

(2) Difficulty to react to a momentary voltage decrease.

For example, the reaction time t_{PHL} is 10 μ s when delay capacitor $C_d = 0.1 \mu$ F.

The momentary voltage-decrease that is longer than such t_{PHL} are occurs, the detection becomes possible. When the delay capacitance is enlarged, t_{PHL} also becomes long. For instance, it becomes about 100 to 200 μ s in case of circuit constant $C_1 = 100 \mu$ F.

(Characteristic graph 1 is used and extrapolation in case of $C_d = 100 \mu$ F.)

Therefore, it doesn't react to momentary voltage-decrease that is shorter than this.

(3) Original delay time is not obtained.

When the momentary voltage-decrease time 't' is equivalent to t_{PHL} , the discharge becomes insufficient and the charge starts at that state. This phenomenon occurs at large capacitance. And, original delay time t_{pd} is not obtained.

Please refer to characteristic graph 2. (Delay time versus input pulse width)

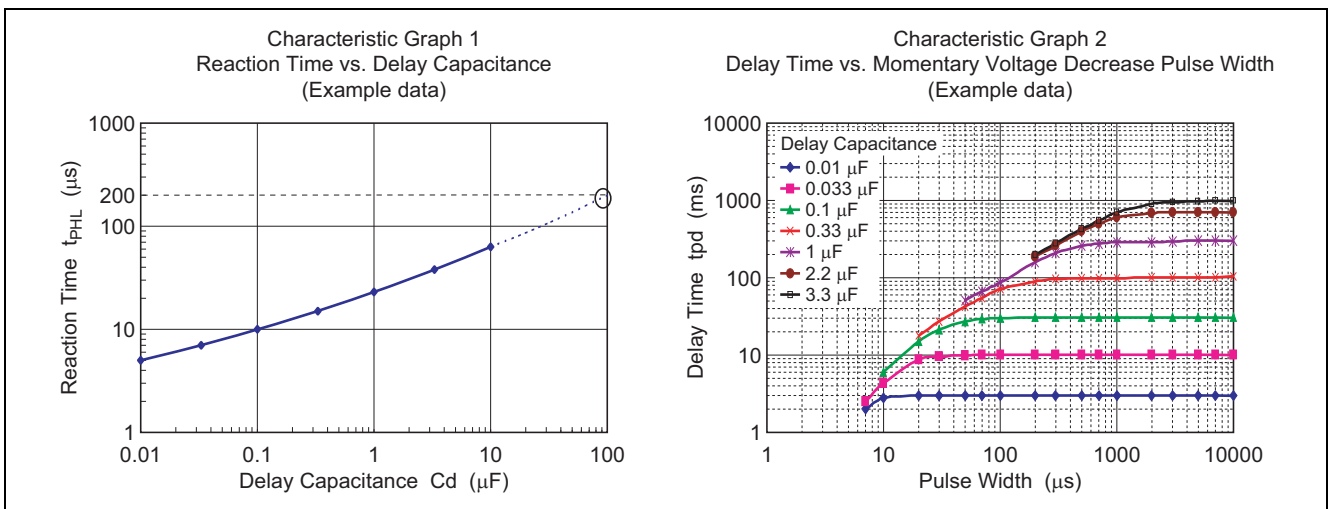

Figure 5 Characteristic Graph

Setting of Output Load Resistance (RNA51953B)

High level output voltage can be set without depending on the power-supply voltage because the output terminal is an open collector type. However, please guard the following notes.

1. Please set it in value (2 V to 17 V) within the range of the power-supply voltage recommendation. Moreover, please never impress the voltage of maximum ratings 18 V or more even momentarily either.
2. Please set output load resistance (pull-up resistance) R_L so that the output current (output inflow current I_L) at L level may become 4 mA or less. Moreover, please never exceed absolute maximum rating (6 mA).

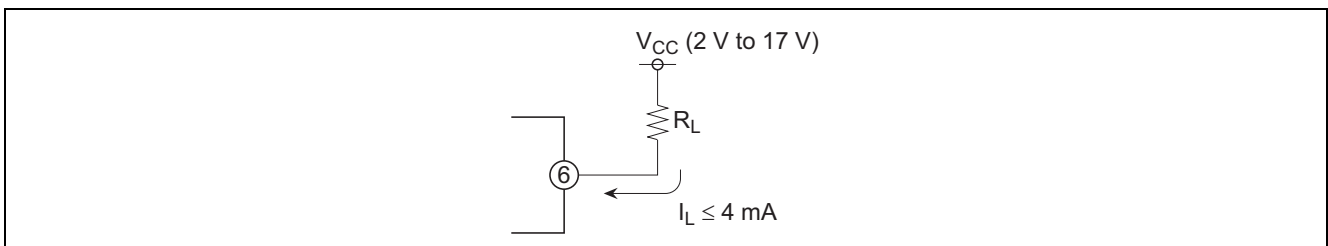

Figure 6 Output Load Resistance R_L

Others

1. Notes when IC is handled are published in our reliability handbook, and please refer it. The reliability handbook can be downloaded from our homepage (following URL). http://www.renesas.com/products/common_info/reliability/index.jsp
2. Additionally, please inquire of our company when there is an uncertain point on use.

Package Dimensions

JEITA Package Code	RENESAS Code	Previous Code	MASS[Typ.]
P-SOP8-4.4x4.85-1.27	PRSP0008DE-C	—	0.1g

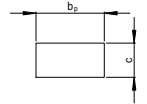
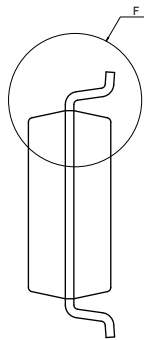
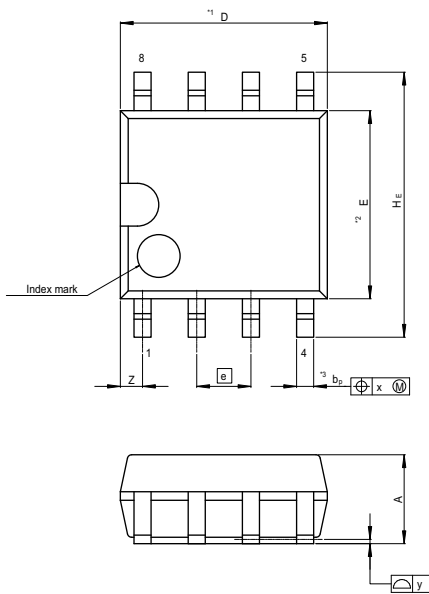

Terminal cross section
(Ni/Pd/Au plating)

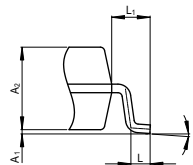

Detail F

NOTE)
1. DIMENSIONS**1 (Nom)**AND**2*
DO NOT INCLUDE MOLD FLASH.
2. DIMENSION**3*DOES NOT
INCLUDE TRIM OFFSET.

Reference Symbol	Dimension in Millimeters		
	Min	Nom	Max
D	4.65	4.85	5.05
E	4.2	4.4	4.6
A ₂	—	1.85	—
A ₁	0.00	0.1	0.20
A	—	—	2.03
b _p	0.34	0.4	0.46
b ₁	—	—	—
c	0.15	0.20	0.25
c ₁	—	—	—
θ	0°	—	8°
H _E	5.7	6.2	6.5
⊕	1.12	1.27	1.42
x	—	—	0.12
y	—	—	0.10
Z	—	—	0.75
L	0.25	0.45	0.65
L ₁	—	0.90	—

JEITA Package Code	RENESAS Code	Previous Code	MASS[Typ.]
P-DIP8-6.3x9.6-2.54	PRDP0008AF-B	DP-8FV	0.54g

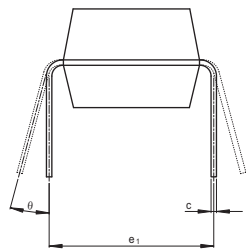
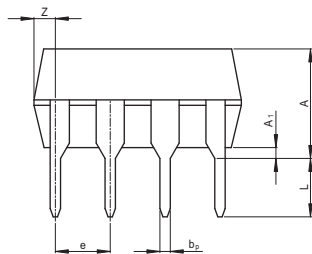
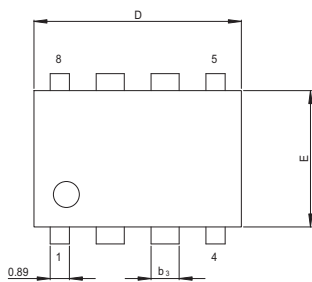

(Ni/Pd/Au plating)

Reference Symbol	Dimension in Millimeters		
	Min	Nom	Max
e ₁	—	7.62	—
D	—	9.60	10.6
E	—	6.30	7.4
A	—	—	5.06
A ₁	0.5	—	—
b _p	0.40	0.48	0.56
b ₃	—	1.30	—
c	0.19	0.25	0.31
θ	0°	—	15°
e	2.29	2.54	2.79
Z	—	—	1.27
L	2.54	—	—

Notice

1. Descriptions of circuits, software and other related information in this document are provided only to illustrate the operation of semiconductor products and application examples. You are fully responsible for the incorporation of these circuits, software, and information in the design of your equipment. Renesas Electronics assumes no responsibility for any losses incurred by you or third parties arising from the use of these circuits, software, or information.
 2. Renesas Electronics has used reasonable care in preparing the information included in this document, but Renesas Electronics does not warrant that such information is error free. Renesas Electronics assumes no liability whatsoever for any damages incurred by you resulting from errors in or omissions from the information included herein.
 3. Renesas Electronics does not assume any liability for infringement of patents, copyrights, or other intellectual property rights of third parties by or arising from the use of Renesas Electronics products or technical information described in this document. No license, express, implied or otherwise, is granted hereby under any patents, copyrights or other intellectual property rights of Renesas Electronics or others.
 4. You should not alter, modify, copy, or otherwise misappropriate any Renesas Electronics product, whether in whole or in part. Renesas Electronics assumes no responsibility for any losses incurred by you or third parties arising from such alteration, modification, copy or otherwise misappropriation of Renesas Electronics product.
 5. Renesas Electronics products are classified according to the following two quality grades: "Standard" and "High Quality". The recommended applications for each Renesas Electronics product depends on the product's quality grade, as indicated below.
"Standard": Computers; office equipment; communications equipment; test and measurement equipment; audio and visual equipment; home electronic appliances; machine tools; personal electronic equipment; and industrial robots etc.
"High Quality": Transportation equipment (automobiles, trains, ships, etc.); traffic control systems; anti-disaster systems; anti-crime systems; and safety equipment etc.
Renesas Electronics products are neither intended nor authorized for use in products or systems that may pose a direct threat to human life or bodily injury (artificial life support devices or systems, surgical implantations etc.), or may cause serious property damages (nuclear reactor control systems, military equipment etc.). You must check the quality grade of each Renesas Electronics product before using it in a particular application. You may not use any Renesas Electronics product for any application for which it is not intended. Renesas Electronics shall not be in any way liable for any damages or losses incurred by you or third parties arising from the use of any Renesas Electronics product for which the product is not intended by Renesas Electronics.
 6. You should use the Renesas Electronics products described in this document within the range specified by Renesas Electronics, especially with respect to the maximum rating, operating supply voltage range, movement power voltage range, heat radiation characteristics, installation and other product characteristics. Renesas Electronics shall have no liability for malfunctions or damages arising out of the use of Renesas Electronics products beyond such specified ranges.
 7. Although Renesas Electronics endeavors to improve the quality and reliability of its products, semiconductor products have specific characteristics such as the occurrence of failure at a certain rate and malfunctions under certain use conditions. Further, Renesas Electronics products are not subject to radiation resistance design. Please be sure to implement safety measures to guard them against the possibility of physical injury, and injury or damage caused by fire in the event of the failure of a Renesas Electronics product, such as safety design for hardware and software including but not limited to redundancy, fire control and malfunction prevention, appropriate treatment for aging degradation or any other appropriate measures. Because the evaluation of microcomputer software alone is very difficult, please evaluate the safety of the final products or systems manufactured by you.
 8. Please contact a Renesas Electronics sales office for details as to environmental matters such as the environmental compatibility of each Renesas Electronics product. Please use Renesas Electronics products in compliance with all applicable laws and regulations that regulate the inclusion or use of controlled substances, including without limitation, the EU RoHS Directive. Renesas Electronics assumes no liability for damages or losses occurring as a result of your noncompliance with applicable laws and regulations.
 9. Renesas Electronics products and technology may not be used for or incorporated into any products or systems whose manufacture, use, or sale is prohibited under any applicable domestic or foreign laws or regulations. You should not use Renesas Electronics products or technology described in this document for any purpose relating to military applications or use by the military, including but not limited to the development of weapons of mass destruction. When exporting the Renesas Electronics products or technology described in this document, you should comply with the applicable export control laws and regulations and follow the procedures required by such laws and regulations.
 10. It is the responsibility of the buyer or distributor of Renesas Electronics products, who distributes, disposes of, or otherwise places the product with a third party, to notify such third party in advance of the contents and conditions set forth in this document, Renesas Electronics assumes no responsibility for any losses incurred by you or third parties as a result of unauthorized use of Renesas Electronics products.
 11. This document may not be reproduced or duplicated in any form, in whole or in part, without prior written consent of Renesas Electronics.
 12. Please contact a Renesas Electronics sales office if you have any questions regarding the information contained in this document or Renesas Electronics products, or if you have any other inquiries.
- (Note 1) "Renesas Electronics" as used in this document means Renesas Electronics Corporation and also includes its majority-owned subsidiaries.
(Note 2) "Renesas Electronics product(s)" means any product developed or manufactured by or for Renesas Electronics.



SALES OFFICES

Renesas Electronics Corporation

<http://www.renesas.com>

Refer to "<http://www.renesas.com/>" for the latest and detailed information.

Renesas Electronics America Inc.
2880 Scott Boulevard Santa Clara, CA 95050-2554, U.S.A.
Tel: +1-408-588-6000, Fax: +1-408-588-6130

Renesas Electronics Canada Limited
1101 Nicholson Road, Newmarket, Ontario L3Y 9C3, Canada
Tel: +1-905-898-5441, Fax: +1-905-898-3220

Renesas Electronics Europe Limited
Dukes Meadow, Millboard Road, Bourne End, Buckinghamshire, SL8 5FH, U.K.
Tel: +44-1628-585-100, Fax: +44-1628-585-900

Renesas Electronics Europe GmbH
Arcadiastrasse 10, 40472 Düsseldorf, Germany
Tel: +49-211-65030, Fax: +49-211-6503-1327

Renesas Electronics (China) Co., Ltd.
7th Floor, Quantum Plaza, No.27 ZhiChunLu Haidian District, Beijing 100083, P.R.China
Tel: +86-10-8235-1155, Fax: +86-10-8235-7679

Renesas Electronics (Shanghai) Co., Ltd.
Unit 204, 205, AZIA Center, No.1233 Lujiazui Ring Rd., Pudong District, Shanghai 200120, China
Tel: +86-21-5877-1818, Fax: +86-21-6887-7858 / -7898

Renesas Electronics Hong Kong Limited
Unit 1601-1613, 16/F., Tower 2, Grand Century Place, 193 Prince Edward Road West, Mongkok, Kowloon, Hong Kong
Tel: +852-2886-9318, Fax: +852 2886-9022/9044

Renesas Electronics Taiwan Co., Ltd.
13F, No. 363, Fu Shing North Road, Taipei, Taiwan
Tel: +886-2-8175-9600, Fax: +886 2-8175-9670

Renesas Electronics Singapore Pte. Ltd.
1 HarbourFront Avenue, #06-10, Keppel Bay Tower, Singapore 098632
Tel: +65-6213-0200, Fax: +65-6278-8001

Renesas Electronics Malaysia Sdn.Bhd.
Unit 906, Block B, Menara Amcorp, Amcorp Trade Centre, No. 18, Jln Persiaran Barat, 46050 Petaling Jaya, Selangor Darul Ehsan, Malaysia
Tel: +60-3-7955-3390, Fax: +60-3-7955-9510

Renesas Electronics Korea Co., Ltd.
11F., Samik Laved' or Bldg., 720-2 Yeoksam-Dong, Kangnam-Ku, Seoul 135-080, Korea
Tel: +82-2-558-3737, Fax: +82-2-558-5141

X-ON Electronics

Largest Supplier of Electrical and Electronic Components

Click to view similar products for [Supervisory Circuits](#) category:

Click to view products by [Renesas](#) manufacturer:

Other Similar products are found below :

[NCP304LSQ38T1G](#) [NCP304LSQ40T1G](#) [NCP304LSQ42T1G](#) [NCP304LSQ43T1G](#) [NCP304LSQ46T1G](#) [NCP305LSQ11T1G](#)
[NCP305LSQ16T1G](#) [NCP305LSQ17T1G](#) [NCP305LSQ18T1G](#) [NCP305LSQ24T1G](#) [NCP305LSQ25T1G](#) [NCP305LSQ29T1G](#)
[NCP305LSQ31T1G](#) [NCP305LSQ32T1G](#) [NCP308MT250TBG](#) [NCP308SN300T1G](#) [NCP391FCALT2G](#) [NCV303LSN42T1G](#)
[NCV308SN330T1G](#) [CAT1161LI-25-G](#) [CAT853STBI-T3](#) [MAX1232CPA](#) [MAX705CPA](#) [CAT1026LI-30-G](#) [CAT1320LI-25-G](#) [CAT872-30ULGT3](#) [LA-ispPAC-POWR1014-01TN48E](#) [NCP304HSQ18T1G](#) [NCP304HSQ29T1G](#) [NCP304LSQ27T1G](#) [NCP304LSQ29T1G](#)
[NCP304LSQ45T1G](#) [NCP305LSQ26T1G](#) [NCP305LSQ35T1G](#) [NCP305LSQ37T1G](#) [NCP308MT300TBG](#) [NCV300LSN36T1G](#)
[NCV302LSN30T1G](#) [NCV303LSN16T1G](#) [NCV303LSN22T1G](#) [NCV303LSN27T1G](#) [NCV33161DMR2G](#) [TC54VN2402EMB713](#)
[MCP1316T-44NE/OT](#) [MCP1316MT-45GE/OT](#) [MCP1316MT-23LI/OT](#) [MCP1316T-26LE/OT](#) [MAX8997EWW+](#) [MAX821RUS+T](#)
[MAX6725AKASYD3-LF-T](#)