

RL78/G24 Motor Control Evaluation Kit

User's Manual

For Your Safety

Be sure to read this manual before using the RL78/G24 Motor Control Evaluation Kit (RTK0EMG24SS00000BJ) (this product).

Please follow the instructions in this manual when using the product.

Keep this manual near the product so you can refer to it whenever necessary.

Transfer or sale of the product to third parties is prohibited without written approval.

The purchaser or importer of the product is responsible for ensuring compliance with local regulations. In addition, the customer is responsible for ensuring that the product is handled correctly and safely, in accordance with the laws of the customer's country (region).

The manual for the product, and specification (the documents) are the tool that was developed for the function and performance evaluation of Renesas Electronics semiconductor device (Renesas Electronics device) mounted on the product, and not guarantee the same quality, function and performance.



By purchasing the product or downloading the documents from Renesas Electronics website, the the support services provided by Renesas Electronics are not guaranteed.

All information contained in this manual represents information on products at the time of publication of this manual. Please note that the product data, specification, sales offices, contents of website, address, etc., are subject to change by Renesas Electronics Corporation without notice due to product improvements or other reasons. Please confirm the latest information on Renesas Electronics website.



In this manual, safety symbols related to the product are described as below.

- The degree of injury to persons or damage to property that could result if the designated content in this manual is not followed is indicated as follows.

 Danger	Indicates content that, if not followed, could result in death or serious injury*1 to the user, and which is highly urgent.
 Warning	Indicates content that, if not followed, could result in death or serious injury to the user.
 Caution	Indicates content that, if not followed, could result in injury*2 to persons or physical damages.*3

Note 1. Serious injury refers to conditions resulting in persistent after-effects and for which treatment would necessitate hospitalization or regular hospital visits, such as loss or impairment of eyesight, burns (high- or low-temperature), electric shock, bone fracture, or poisoning.

Note 2. Injury refers to conditions for which treatment would necessitate hospitalization or regular hospital visits.

Note 3. Physical damage refers to damage affecting the wider surroundings, such as the user's home or property.

■ Requirements related to the handling of the product are classified into the following categories.



● Marks indicating that an action is prohibited.

	<p>General Prohibition The indicated action is prohibited.</p>		<p>Example: Do Not Touch! Touching the specified location could result in injury.</p>
---	---	---	--

● Marks indicating that an action is prohibited.





	<p>General Caution Indicates a general need for caution that is not specified.</p>		<p>Example: Caution – Hot! Indicates the possibility of injury due to high temperature.</p>
---	---	---	--

● Marks directing that the specified action is required.







	<p>General Instruction The specified action is required.</p>		<p>Example: Turn Off (Disconnect) Power Supply! Instructs the user to turn off (disconnect) the power supply to the product.</p>
---	---	---	---

Warnings Regarding Use of the Product



■ Danger Items

 Danger	
  	<p>The product should be used only by persons (users) having a thorough knowledge of electrical and mechanical components and systems, a full knowledge of the risks associated with handling them, and training in inverter motor control and handling motors, or equivalent skills. Users should be limited to persons who have carefully read the Caution Items contained in this manual.</p> <p>Unlike typical equipment, the product has no protective case to ensure safety, and it contains moving parts and high-temperature components that could be dangerous. Do not touch the evaluation board or cables while power is being supplied.</p> <p>Carefully check to make sure that there are no pieces of conductive materials or dust adhering to the board, connectors, and cables.</p> <p>There are moving parts, driven by a motor. Do not touch the motor while power is being supplied.</p> <p>Ensure that the motor is insulated and placed in a stable location before supplying power.</p>

■ Warning Items

 Warning	
	<p>Caution – Rotating Parts! The system includes a motor. Touching the rotating shaft could cause high-temperature burns or injury.</p>
	<p>Always insert plugs, connectors, and cables securely, and confirm that they are fully inserted. Incomplete connections could cause fire, burns, electric shock, or injury.</p>
	<p>Use the power supply apparatus specified in the manual. Failure to do so could cause fire, burns, electric shock, injury, or malfunction.</p>
	<p>Disconnect the power supply and unplug all cables when the system will not be used for a period of time or when moving the system. Failure to do so could cause fire, burns, electric shock, or malfunction. This will protect the system against damage due to lightning.</p>
	<p>Use a mechanism (switch, outlet, etc.) located within reach to turn off (disconnect) the power supply. In case of emergency, it may be necessary to cut off the power supply quickly.</p>
	<p>Turn off the power supply immediately if you notice abnormal odor, smoke, abnormal sound, or overheating. Continuing to use the system in an abnormal condition could cause fire, burns, or electric shock.</p>
	<p>Do Not Disassemble, Modify, or Repair! Failure to do so could cause fire, burns, electric shock, injury, or malfunction.</p>
	<p>Do not use the product for any purpose other than initial evaluation of motor control in a testing room or lab. Do not integrate the product or any part of it into other equipment. Do not insert or remove cables or connectors when the product is powered on. The product has no safety case. Failure to observe the above could cause fire, electric shock, burns, or malfunction. The product may not perform as expected if used for other than its intended purpose.</p>

■ Caution Items

 Caution	
	<p>Caution – Hot! The motor gets hot. Touching it could cause high-temperature burns.</p>
	<p>Follow the procedure specified in the manual when powering the system on or off. Failure to do so could cause overheating or malfunction.</p>

Summary

The RL78/G24 Motor Control Evaluation Kit (RTK0EMG24SS00000BJ) is a motor control evaluation kit that enables evaluation of PMSM control using the RL78/G24 motor control microcontroller.

This user's manual describes the proper handling of the product.

In addition, this product supports the support tool for motor control development manufactured by Renesas Electronics (Renesas Motor Workbench: RMW). RMW combines convenient functions for motor control evaluation, such as real-time waveform display of microcontroller internal variables and automatic extraction of vector control parameters.

Onboard Renesas Electronics Products

Microcontroller	: R7F101GLG2DFB (RL78/G24 microcontroller)*
Gate Driver	: HIP2101BZ
MOSFET	: RJK0703DPP-A0
DC-DC Regulator	: ISL8560IRZ, ISL85003FRZ
Operational Amplifier	: READ2302GSP

: All products of the RL78/G24 group (with ordering part numbers of R7F101Gxxxxxx#xx0; each x indicates a specific letter or numeral) have restrictions. For more information, RENESAS TECHNICAL UPDATE (TN-RL-A0127A/E) for more information.

Contents

1. Overview	6
2. Product Contents.....	6
3. Hardware Overview	7
4. Hardware Configuration.....	11
5. Board Layout	12
6. How to use	14
7. User Interface Specifications	17
8. Alternate Function Pins	18
9. Sample Connection For Use.....	21
10. Inverter Board Specifications.....	22
11. CPU card specifications	27
12. Communication Board Functions.....	33
13. Design and Manufacture Information.....	34
14. Website and Support	34

1. Overview

This user's manual describes a control evaluation kit that drives PMSM using the RL78/G24 microcontroller. The features of the evaluation kit are shown below.

- (1) Evaluation with the "RL78/G24" motor control microcontroller is possible.
- (2) PMSM can be driven.
- (3) Can detect 3-shunt current and 1-shunt current.
- (4) Input voltage of 12V to 50V. (The customer must provide their own power supply for this product.)
- (5) Output peak current: 30A
- (6) Supports various sensor inputs (such as encoder and hall sensors), serial communications.
- (7) Motor control development support tool RMW available.
- (8) Interchangeable with compatible CPU cards.

(Renesas Electronics products: RTK0EML240C03000BJ, RTK0EML130C06000BJ, Desktop Lab products: T5103, T5101)

2. Product Contents

This kit consists of the following parts.

1. Low voltage Inverter Board LV400 (RTK0EMGPLVB00000BJ) x1
2. RL78/G24 CPU Card (RTK0EMG240C00000BJ) x1
3. Communication Board MC-COM (RTK0EMXC90Z00000BJ) x1
4. PMSM (TG-55L-KA: TSUKASA Co., Ltd. product) x1
5. Communication Cable x1
6. USB Cable x1
7. Motor Cable x1
8. Standoff x 4
9. Screw x 4

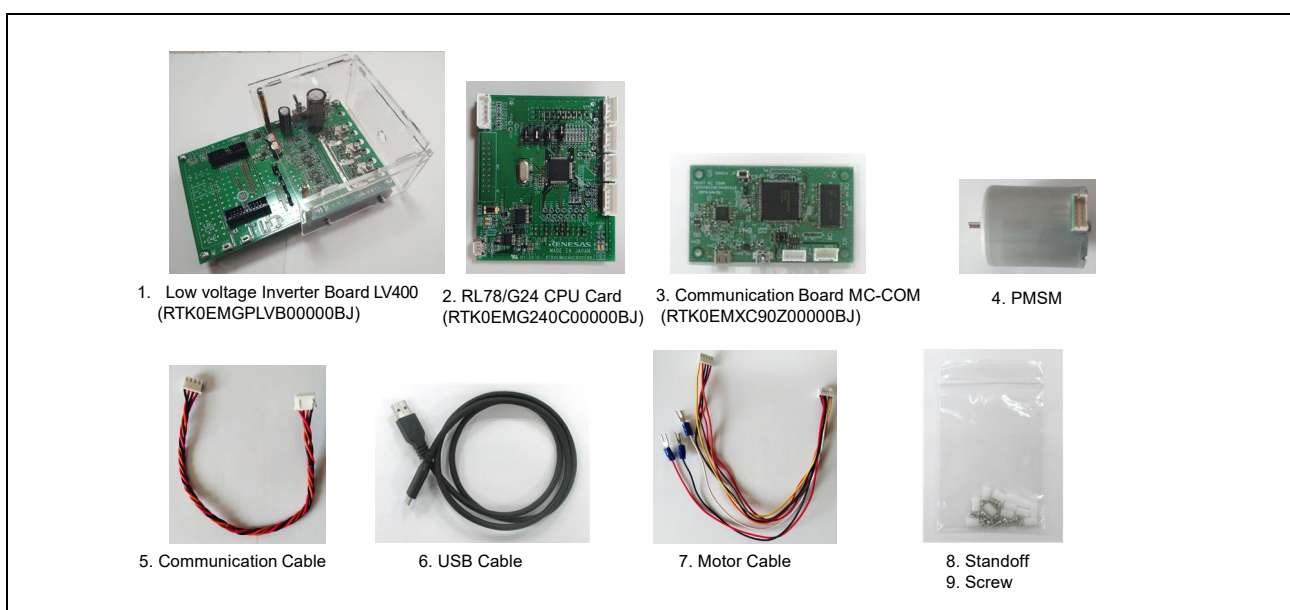

Figure 2-1 Product Configuration

3. Hardware Overview

The RL78/G24 Motor Control Evaluation Kit (RTK0EMG24SS00000BJ) consists of an inverter board, CPU card and communication board. The specifications are shown below.

Table 3.1 Specifications of RL78/G24 Motor Control Evaluation Kit (RTK0EMG24SS00000BJ)

Item	Specification	
Product name	RL78/G24 Motor Control Evaluation Kit	
Kit model name	RTK0EMG24SS00000BJ	
Kit configuration	Inverter board LV400	RTK0EMGPLVB00000BJ
	CPU card	RTK0EMG240C00000BJ
	Communication board	RTK0EMXC90Z00000BJ
	PMSM	TG-55L-KA (TSUKASA Co., Ltd.)
Isolation	Inverter board - CPU card: Non-isolated Communication board - CPU board: Isolated	
External view	 <p style="text-align: center;">Note: The actual product may differ from this photo.</p>	
Board size	Inverter board LV400: 100mm(W)×160mm(H) CPU card : 79mm(W)×66mm(H) Communication board : 89mm(W)×52mm(H)	
Heat dissipation measures	Natural air cooling with heat sinks	
Operating temperature	Room temperature	
Operating humidity	No condensation allowed	

Table 3.2 Specifications of Low voltage Inverter Board (RTK0EMGPLVB00000BJ)

Item	Specification
Product name	Low voltage Inverter Board for Motor Control Evaluation Kit - LVI400
Board model name	RTK0EMGPLVB00000BJ
Operating input voltage	12V to 50V
Maximum output current	30A (peak current for each phase)
Driving monitor	3-phase PMSM
Current detection method	Detects current using a shunt resistor for 3-phase and DC link.
DC bus voltage detection	Detects using a resistance divider circuit.
3-phase output voltage detection	Detects using a resistance divider circuit.
PWM logic	Positive for both upper and lower arms.
Overcurrent detection	Available by specifying the RL78/G24 MCU setting (PWMOPA) (No detection circuit is provided.)
Dead time	1 μ s (Recommended value)
Switch	<ul style="list-style-type: none"> ● Two tact switches ● Inverter power toggle switch
LEDs	<ul style="list-style-type: none"> ● Two LEDs ● Inverter Power LED ● +5V power LED
Connectors	<ul style="list-style-type: none"> ● CPU card connector: CNA, CNB ● Two analog signal input connectors: CN1 and CN2
Jumper pins	Current Amplifier Switching: magnification is 1/5/50 times: JP7 Current Amplifier Switching: magnification is 5/50 times: JP8, JP9, JP10
Screw terminals	<ul style="list-style-type: none"> ● Power input: P, N ● Motor output: U, V, W
External view	

Note: The actual product may differ from this photo.

Table 3.3 Specifications of RL78/G24 CPU Card (RTK0EMG240C0000BJ)

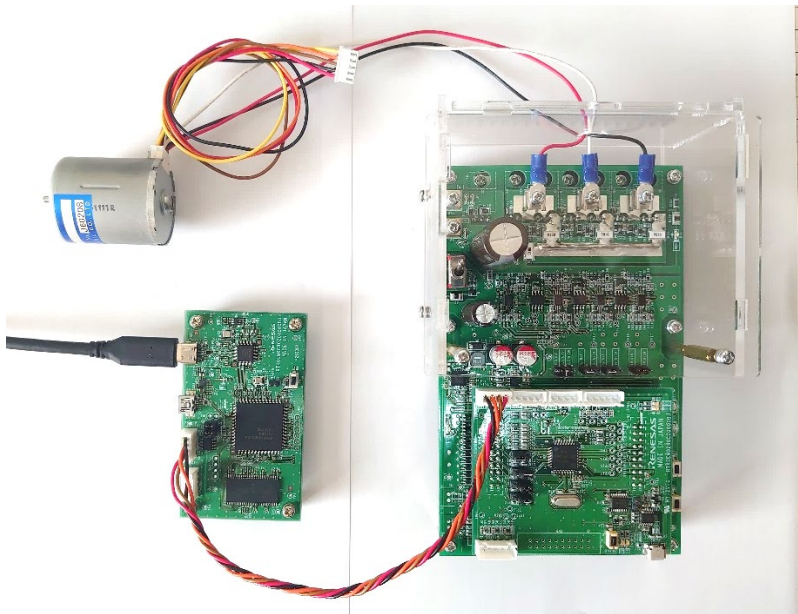
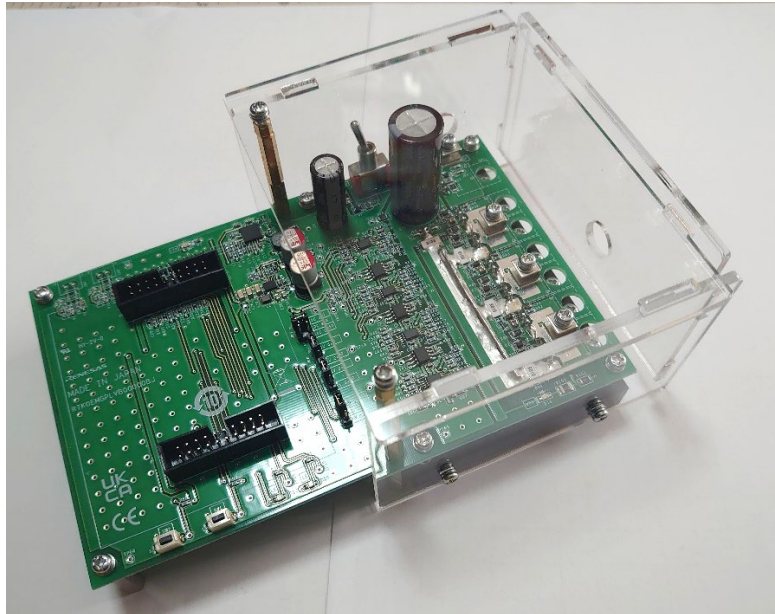

item	Specification	
Product name	RL78/G24 CPU Card for Motor Control Evaluation Kit	
Board model name	RTK0EMG240C0000BJ	
Mounted MCU	Product name	R7F101GLG2DFB
	CPU maximum operating frequency	48 MHz
	Bit number	16 bit
	Package / Pin number	LQFP / 64pin
	ROM	128 KB
	RAM	12 KB
Input power supply voltage	DC 5V Automatically select one of the following <ul style="list-style-type: none"> Power supply from compatible inverter board Power supply from USB connector 	
Switch	MCU reset switch	
LED	<ul style="list-style-type: none"> Two LEDs Two USB communication LED 	
Connectors	<ul style="list-style-type: none"> Inverter board connector:CN1,CN2 ABZ encoder input connector:CN3 UVW Hall signal input connector:CN4 COM Port Micro USB connector for debugging:CN5 Three serial communication connectors: CN6,CN7,CN8 Unused pin connectors:CN9 	
Jumper pins	<ul style="list-style-type: none"> V-phase voltage / Encoder A-phase switching: JP2 U-phase voltage / Encoder Z-phase switching: JP3 W phase voltage / Encoder B phase switching: JP4 W-phase current / GND switching: JP5 	
外観	 <p>Note: The actual product may differ from this photo.</p>	

Table 4-1 Communication board MC-COM specification

item	Specification	
Product name	MC-COM Renesas Flexible Motor Control Communication Board	
Board model name	RTK0EMXC90Z00000BJ	
External view	 <p>Note: The actual product may differ from this photo.</p>	
Mounted MCU	Product group	RX72N group
	Product name	R5F572NNDDFB
	CPU maximum operating frequency	240MHz
	Bit number	32 bit
	Package / Pin number	LFQFP / 144 pin
	RAM	1M byte
MCU input clock	20MHz (Generate with external crystal oscillator)	
Input power supply voltage	<ul style="list-style-type: none"> DC 5V Power is supplied from USB connector 	
Connector	<ul style="list-style-type: none"> USB Type-C connector Mini USB Typ-B connector (not available for users) SCI connector for RMW communication 	
Isolation	<ul style="list-style-type: none"> Between SCI connector and MCU 1kV_{RMS} or larger 	
Switch	MCU reset switch	

4. Hardware Configuration

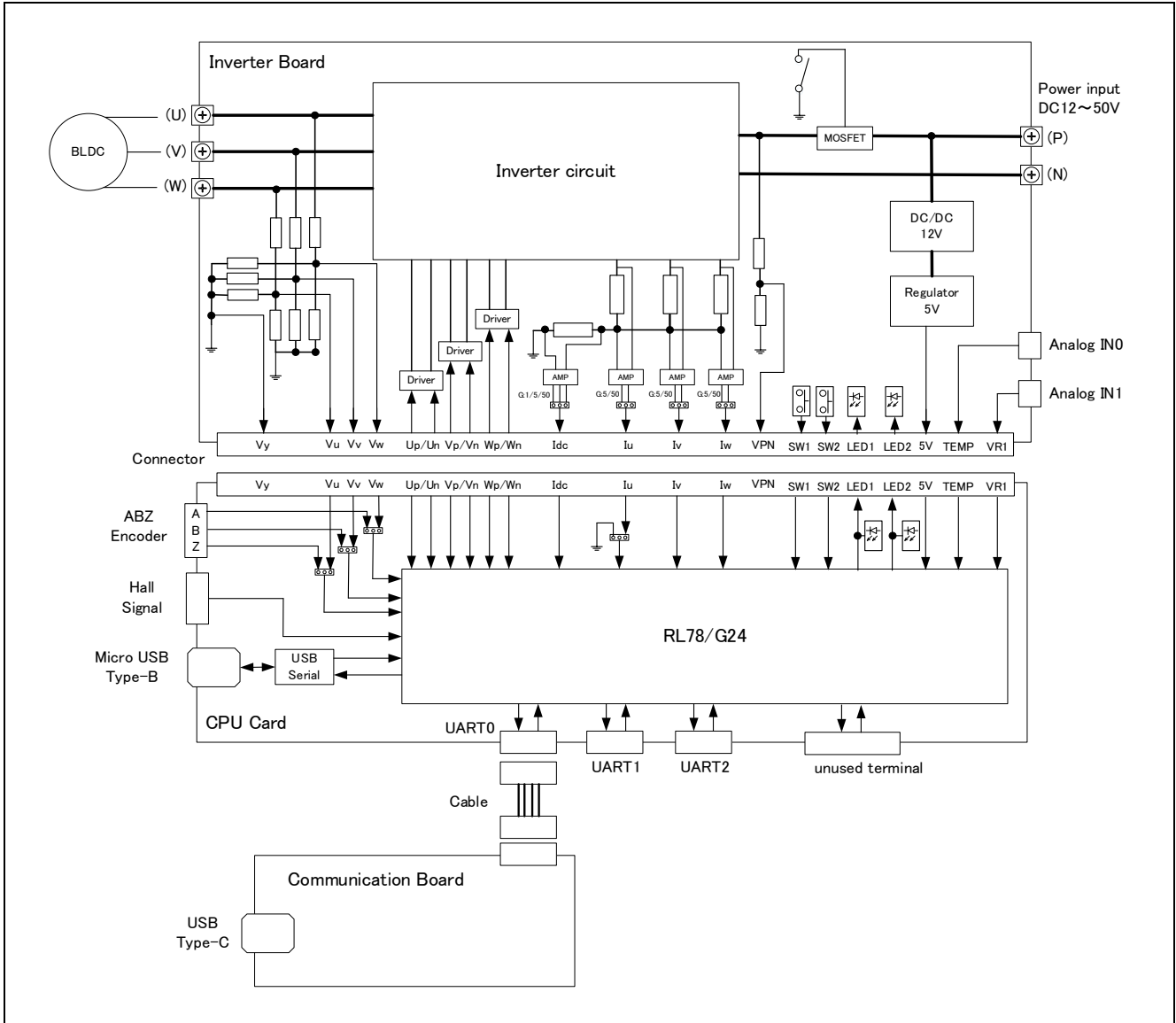

Figure 4-1 Hardware Configuration

5. Board Layout

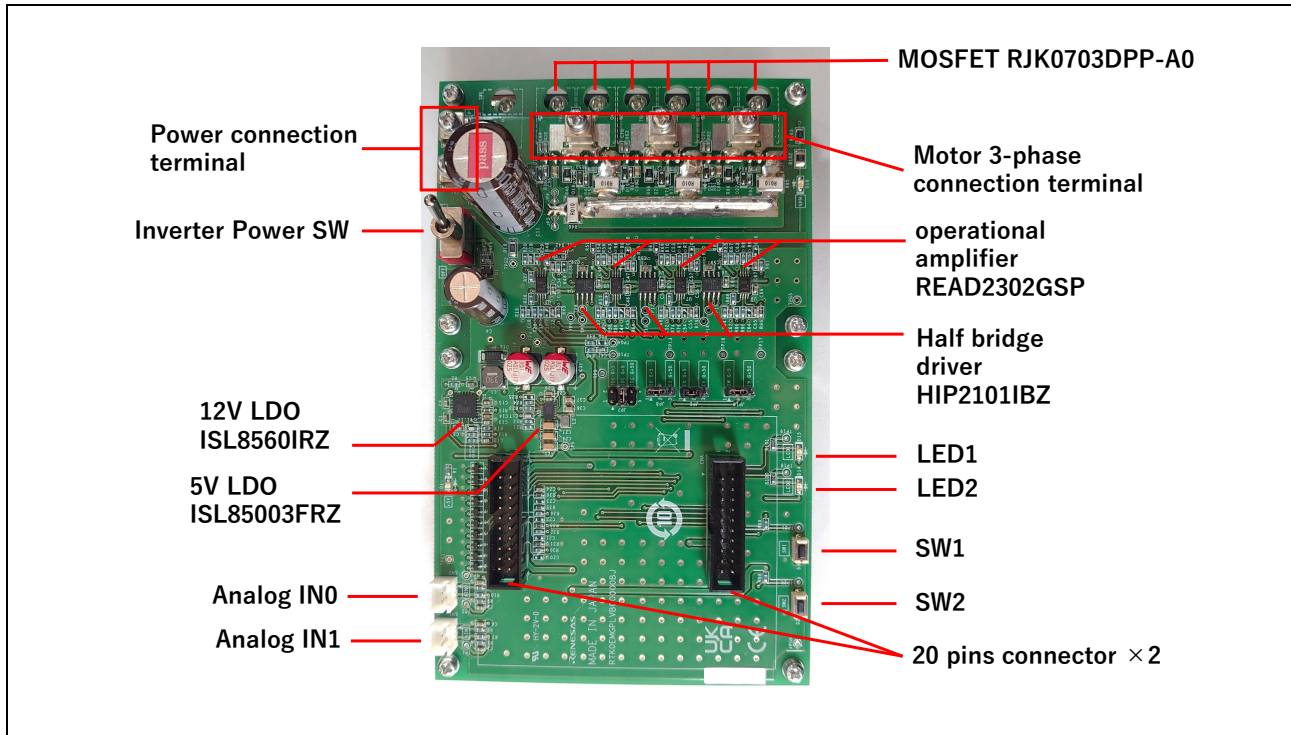

Figure 5-1 Inverter Board LV400

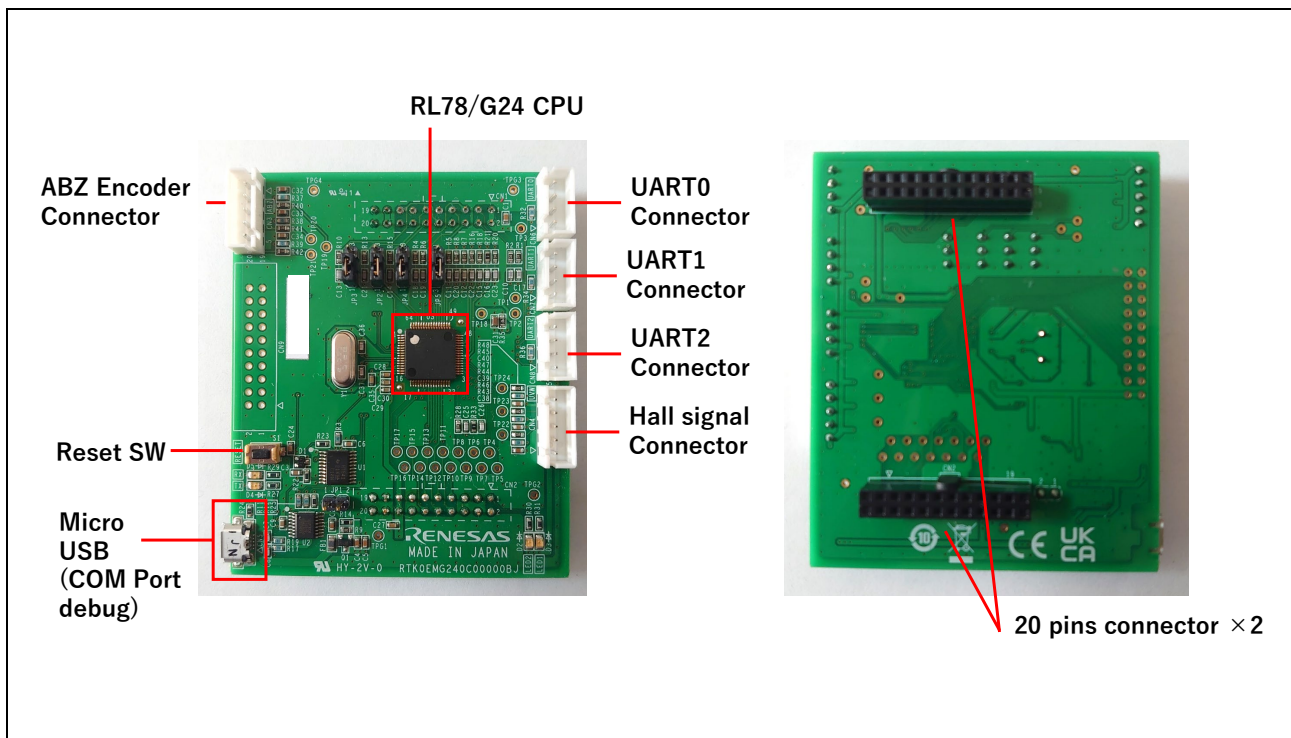

Figure 5-2 CPU Card

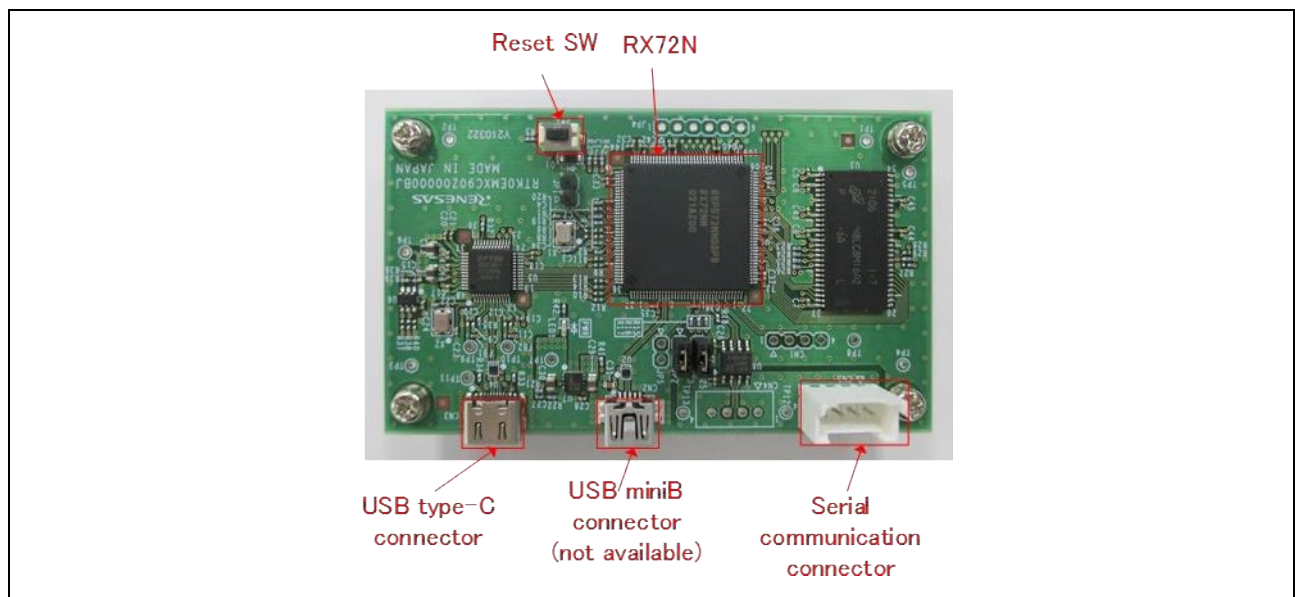

Figure 5-3 CPU Card

6. How to use

This section describes the operating procedures after the product has been opened.

6.1 Quick Start Guide 1: Check initial operation.

The initial operating program has already been written to the CPU card immediately after the kit is opened. A simple operation check can be performed by connecting the board to the PMSM.

Preparation: Prepare a regulated power supply capable of supplying 24V1A, two cables for connection to the power supply, and a Phillips-head screwdriver.

Step 1: Take out the inverter board, PMSM, and cables from the kit's packing box.



Step 2: Remove the screws from the top panel of the inverter board.

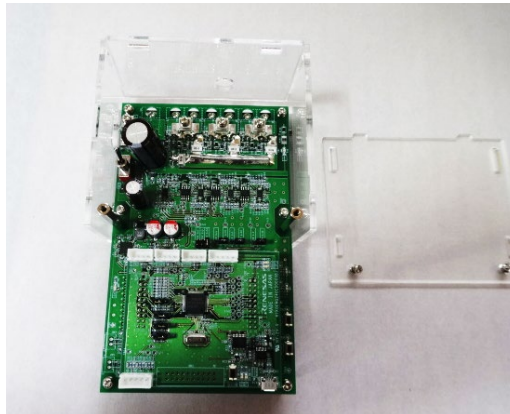

Step 3: Screw in the PMSM cable and power cable. Attach the top panel again.

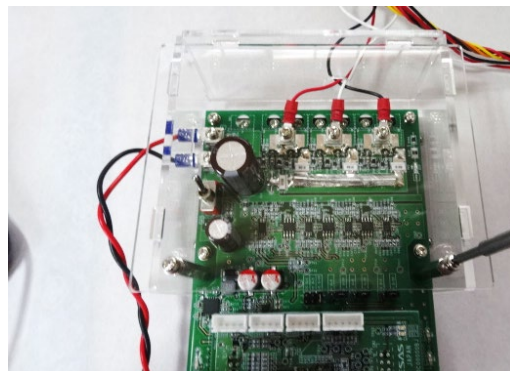

Step 4: Connect the PMSM.

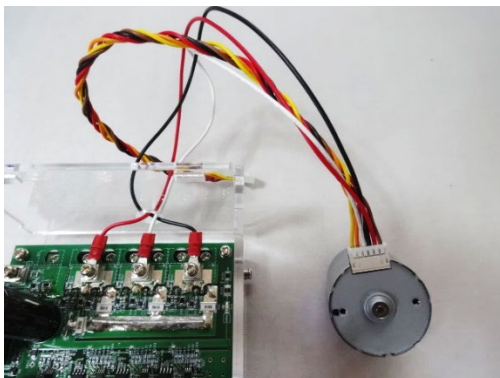

Step 5: Turn on the regulated power supply and confirm that the LED lights up.

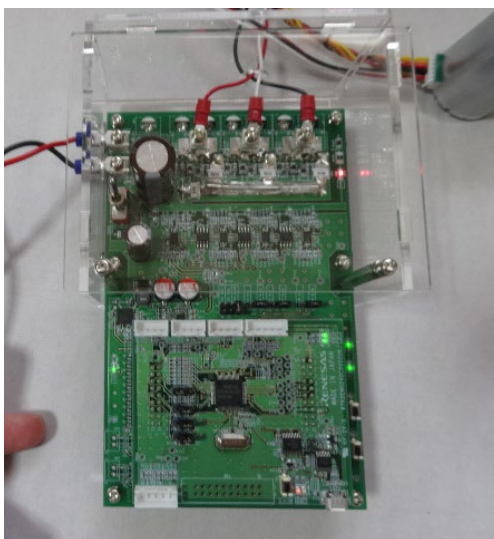

Step 6: Confirm that pressing SW1 drives the PMSM and pressing SW2 stops the PMSM.

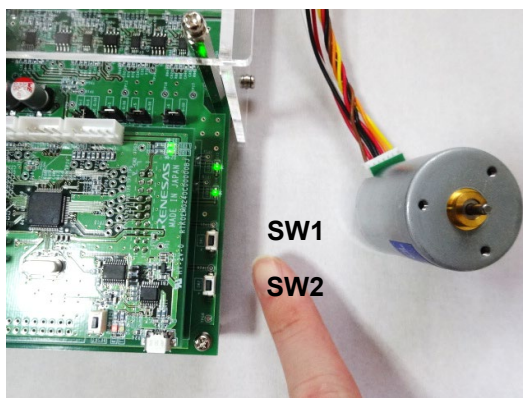

6.2 Quick Start Guide 2: Confirming Operation Using Sample Software

This section describes the setup during operation using the sample software.

Step 1: Connect to the state of Quick Start Guide 1. Power should be turned off or disconnected.

Step 2: Connect the communication board to the inverter board and connect the communication board to the PC. Connect CN6 on the CPU card to CN4 on the communication board.

Connect the communication board and PC with the supplied USB type-A to C cable.

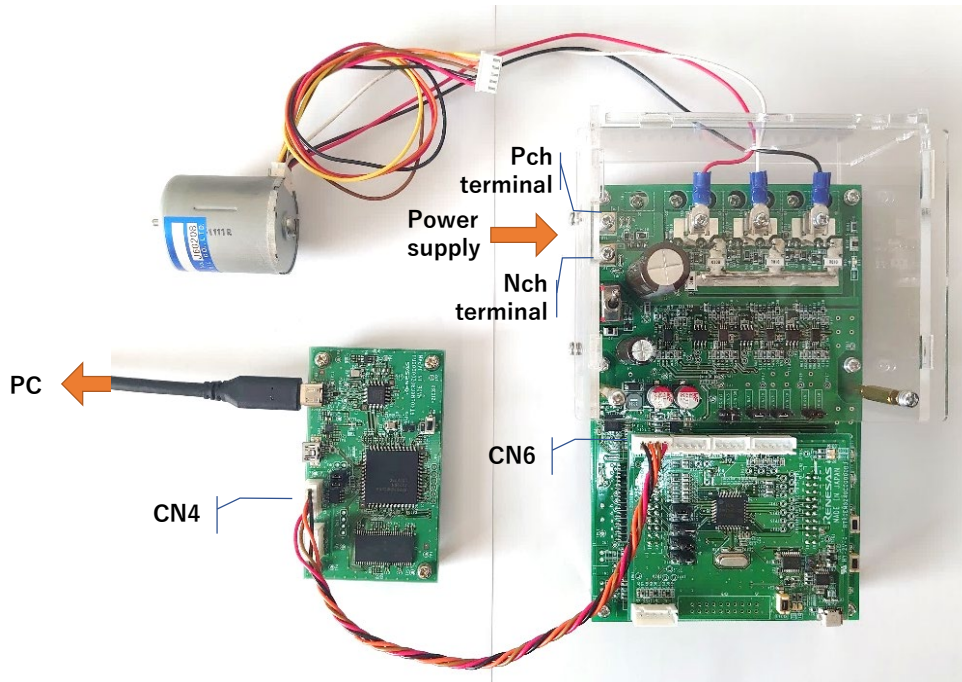

Step 3: Write the sample software to the CPU card.

Connect the CPU card and PC with a USB type A to micro B cable to write the sample software.

When writing, the COM number of the target CPU card must be selected on the IDE.

Refer to the IDE manual for details.

Step 4: Turn on the power and run the sample software according to the application note of the sample software.

7. User Interface Specifications

Table 7.1 Table 7.2 lists the user interface parts on this system.

Table 7.1 User Interface (Inverter Board)

Item	Interface Parts	Function
SW1	Tact switch	Can be defined by user
SW2	Tact switch	Can be defined by user
LED1	Yellow-green LEDs	Can be defined by user
LED2	Yellow-green LEDs	Can be defined by user

Table 7.2 User Interface (CPU Card)

Item	Interface Parts	Function
RESET	Tact switch (RESET1)	System reset
LED1	Yellow-green LEDs	Can be defined by user
LED2	Yellow-green LEDs	Can be defined by user
RX	Red LEDs	USB to serial communication
TX	Yellow-green LEDs	USB to serial communication

Table 7.3 Table 7.4 lists the connector interface pins on this system.

Table 7.3 Connector Interface

Item	Pin Count	Function
CNA	20	CPU card connector
CNB	20	CPU card connector
CN1	2	Analog input
CN2	2	Analog input

Table 7.4 Connector Interface

Item	Pin Count	Function
CN1	20	Inverter Board Connectors
CN2	20	Inverter Board Connectors
CN3	5	ABZ encoder
CN4	5	Hall sensor signal input
CN5	-	Micro USB
CN6	4	Serial communication
CN7	4	Serial communication
CN8	4	Serial communication

8. Alternate Function Pins

The initial settings and functions of each jumper pin are shown below.

Table 8.1 Initial setting and function of jumper pins (inverter board)

Jumper pin	Default setting	Function
JP7	5-6pin short	1-2pin short: Idc current amplification amplifier 1x 3-4pin short: Idc current amplification amplifier 5x 5-6pin short: Idc current amplification amplifier 50x
JP8	2-3pin short	1-2pin short: Iu current amplification amplifier 5x 2-3pin short: Iu current amplification amplifier 50x
JP9	2-3pin short	1-2pin short: Iv current amplification amplifier 5x 2-3pin short: Iv current amplification amplifier 50x
JP10	2-3pin short	1-2pin short: Iw current amplification amplifier 5x 2-3pin short: Iw current amplification amplifier 50x

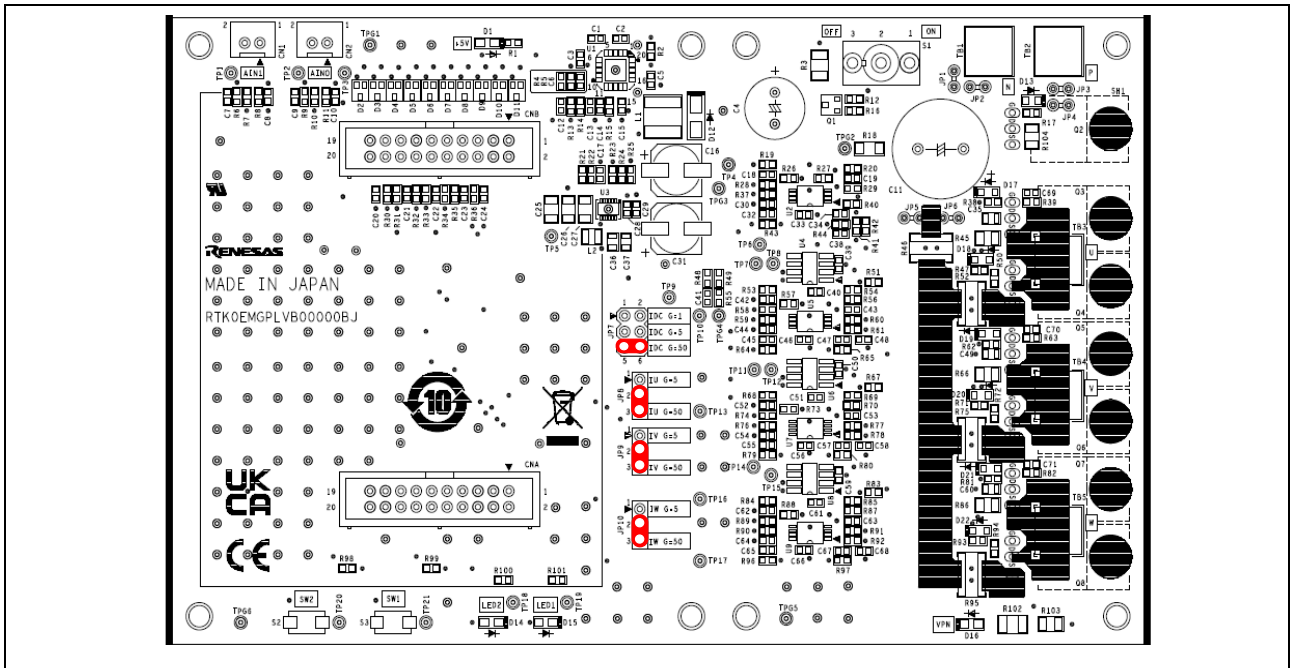

Figure 8-1 Jumper Pin Assignment on Board - Inverter Board

Table 8.2 Initial setting and function of jumper pins (CPU Card)

Jumper pin	Default setting	Function
JP2	1-2pin short	1-2pin short: V-phase voltage 2-3pin short: Encoder phase-A
JP3	1-2pin short	1-2pin short: U-phase voltage 2-3pin short: Encoder phase-Z
JP4	1-2pin short	1-2pin short: W-phase voltage 2-3pin short: Encoder phase-B
JP5	1-2pin short	1-2pin short: W-phase voltage 2-3pin short: GND

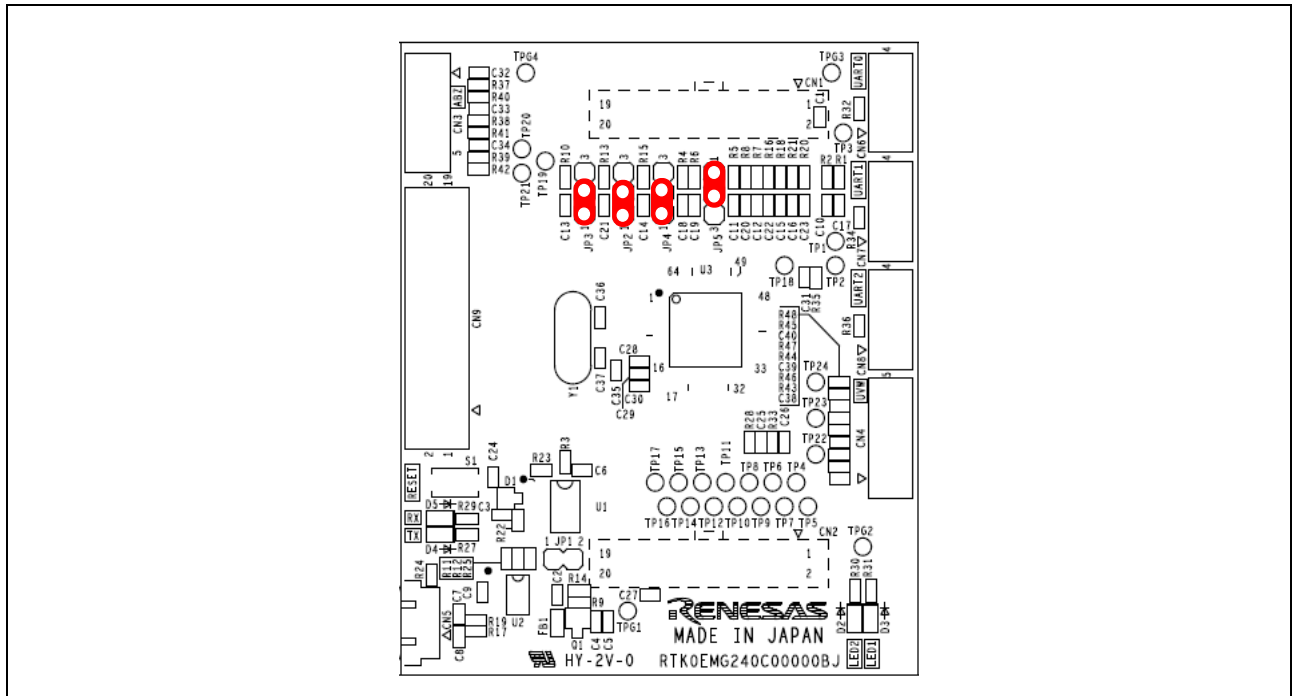

Figure 8-2 Jumper Pin Assignment on Board - Inverter Board

Table 8.3 Initial setting and function of jumper pins (CPU Card)

Jumper pin	Default setting	Function
JP1	1-2pin open	1-2pin short : Enable pull-up for MD port (Not available) 1-2pin open : Enable pull-up for MD port
JP2	1-2pin short	1-2pin short : Disable pull-up for GPIO(PC6) 1-2pin open : Enable pull-up for GPIO(PC6)
JP3	1-2pin short	1-2pin short : Disable pull-up for GPIO(PC5) 1-2pin open : Enable pull-up for GPIO(PC5)

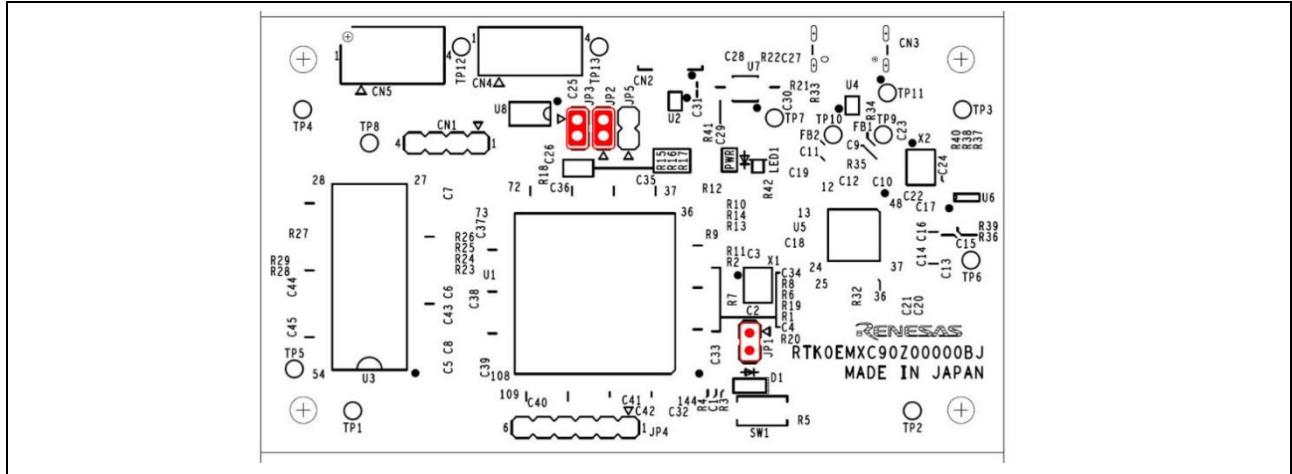

Figure 8-3 Jumper Pin Assignment on Board – Communication Board

9. Sample Connection For Use

When using the inverter, connect the inverter board, CPU card, communication board, and PMSM as shown in the **Figure 9-1**. Use a DC power supply or a regulated power supply within the input voltage range of the inverter board.

The figure is a connection example. Please set up and use in accordance with the sample software and application notes to be used.

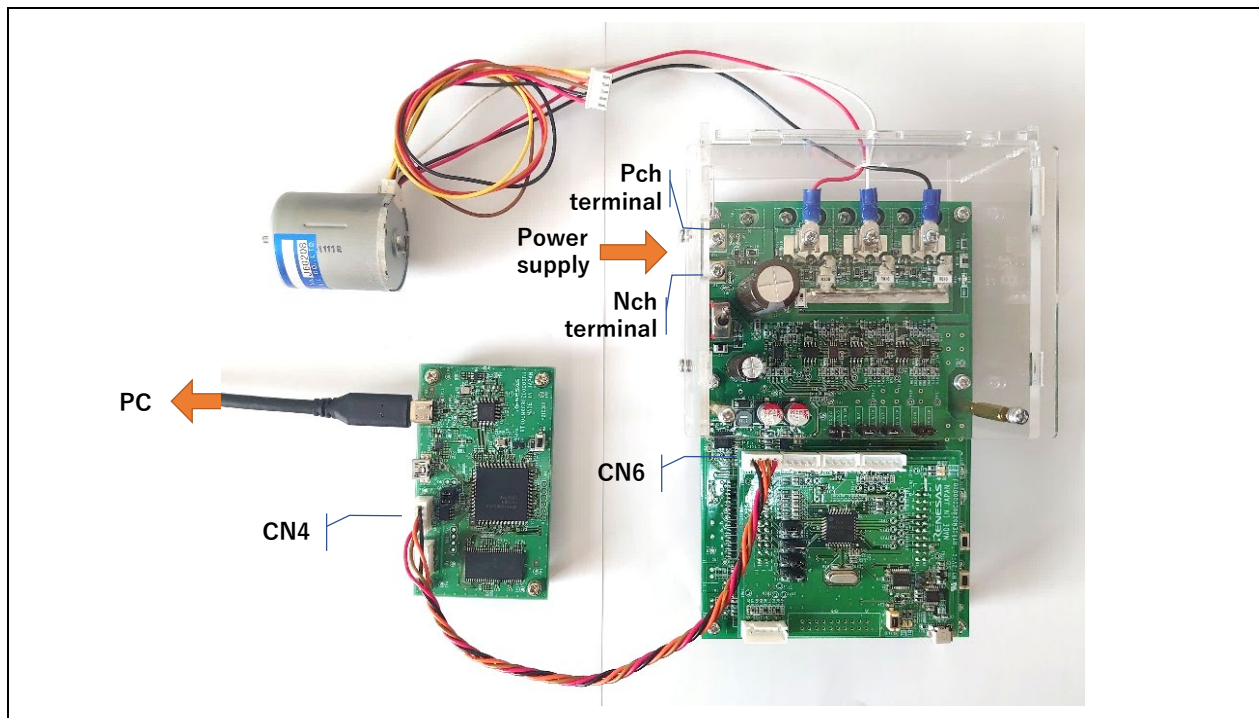

Figure 9-1 Sample Board Connection

10. Inverter Board Specifications

10.1 Circuit Functions

10.1.1 Inverter Control Circuit

The inverter control circuit controls the motor using six MOSFETs. The MOSFET uses the 6-phase timer outputs from the microcontroller via the gate driver IC.

The inverter control circuit inputs the DC line voltage, U-phase voltage, V-phase voltage, W-phase voltage, and shunt current to the A/D pins of the microcontroller. The analog values of each voltage and shunt current can thus be measured. See sections 10.1.2 and 0 for details about how to detect the current and voltage, respectively. The current in each phase can be selected with a gain of 5 or 50 times.

Figure 10-1 shows a schematic diagram of the inverter control circuit. Note that the inputs to the A/D pins may actually pass through a voltage divider or an offset device. See the circuit diagram for details.

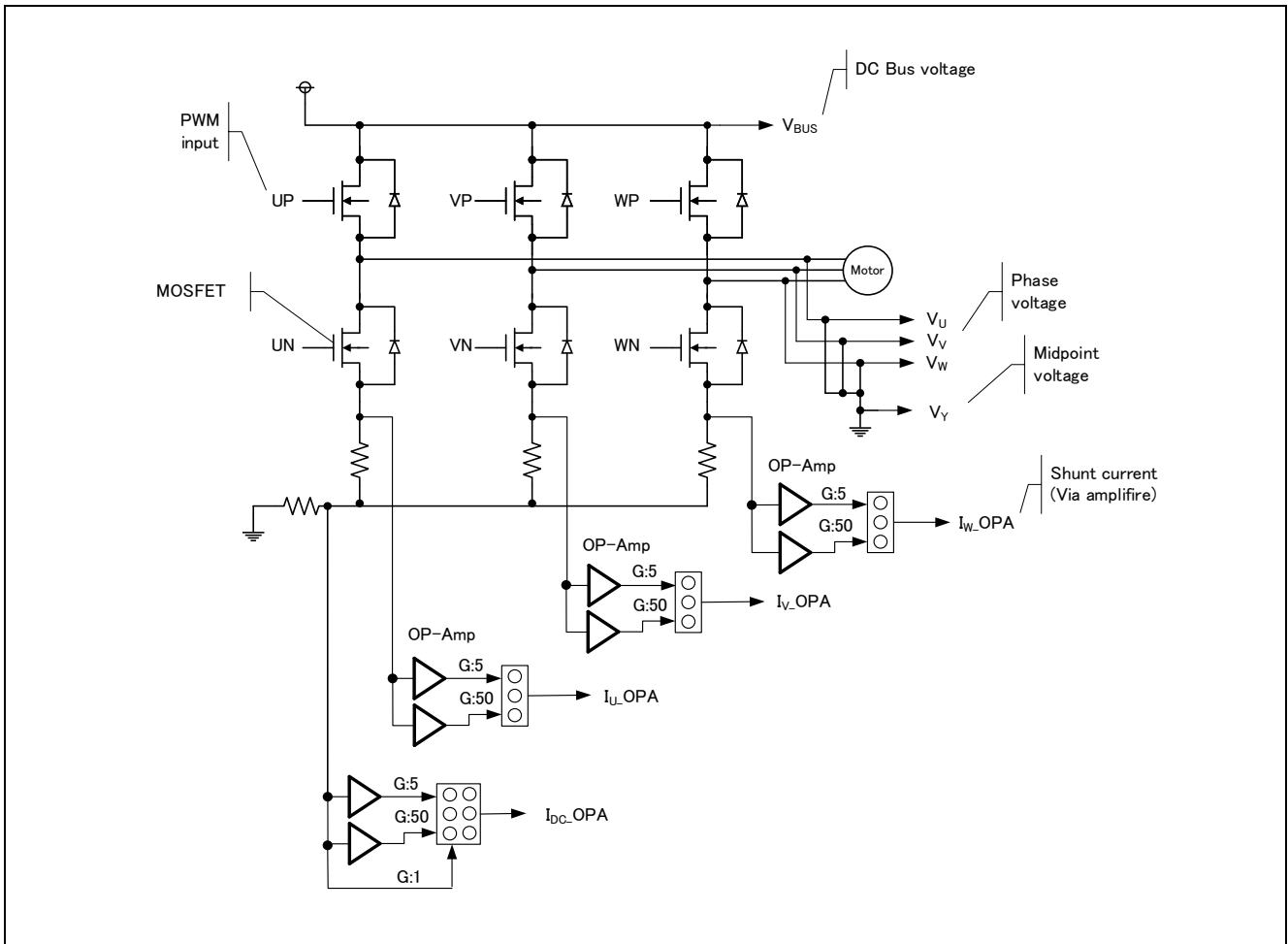

Figure 10-1 Schematic Diagram of Inverter Control Circuit

10.1.2 Current Detection Circuit

The current detection circuit is integrated to measure the U-phase, V-phase, and W-phase current. The current detection circuit is configured by mounting a shunt resistor for the U-phase, V-phase, and W-phase. The voltage drop generated when the current passes through the shunt resistor is amplified by the operational amplifier and then input to the microcontroller. The equation (1) below shows the relationship between the current I_{in} running through the shunt resistor and the voltage V_{out} input to the microcontroller. The gain can be changed by switching the jumper short in each phase.

$$\text{Gain x5: } V_{out}[V] = I_{in}[A] \times R_s[\Omega] \times \frac{B=10k\Omega}{A=2k\Omega} + 2.5 \quad (1)$$

$$\text{Gain x50: } V_{out}[V] = I_{in}[A] \times R_s[\Omega] \times \frac{B=100k\Omega}{A=2k\Omega} + 2.5 \quad (2)$$

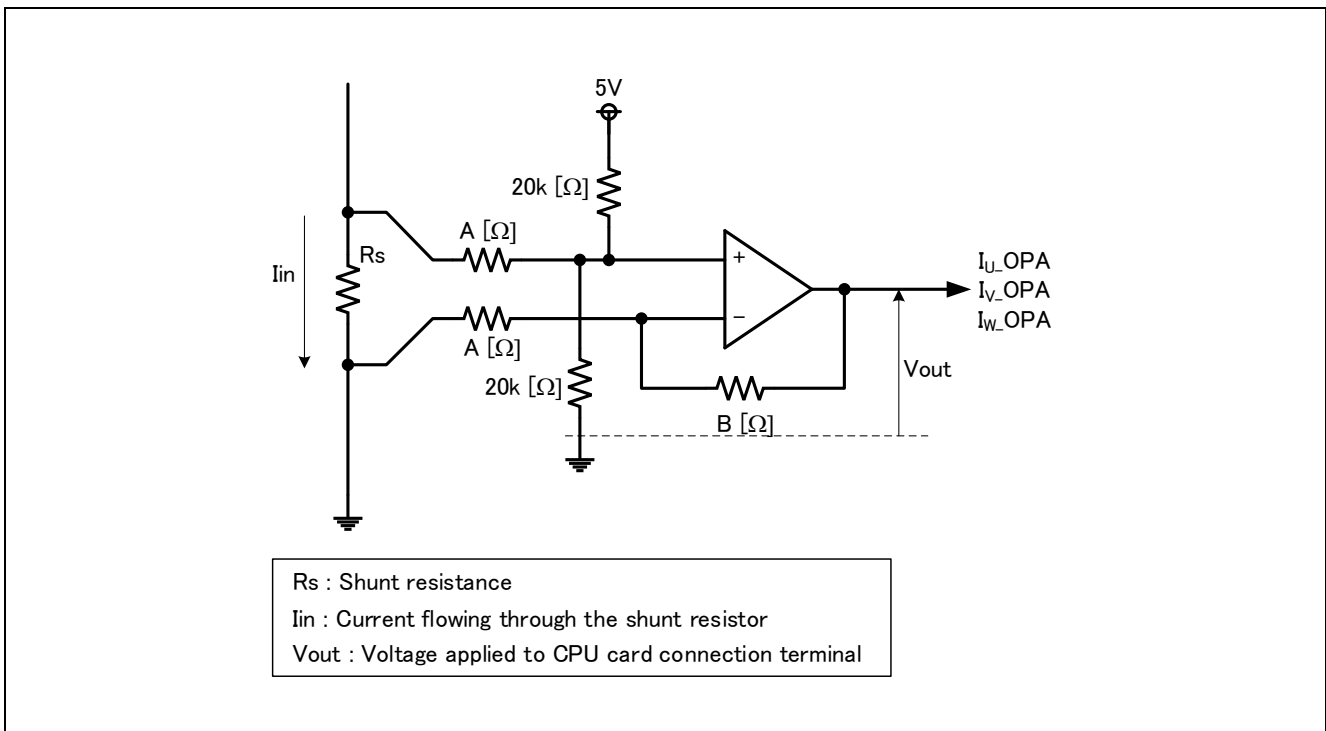

Figure 10-2 Schematic Diagram of Current Detection Circuit

10.1.3 Output Voltage Detection Circuit

The inverter board integrates a circuit used to input the bus line voltage and 3-phase output voltage (U-phase, V-phase, and W-phase) to the A/D pins of the microcontroller via a resistance voltage divider. The equation (3) below shows the relationship between the 3-phase output voltage, bus line voltage, and detection voltage.

$$V_{out}[V] = \frac{470}{10 \times 10^3 + 470} \times V_{in}[V] \quad (3)$$

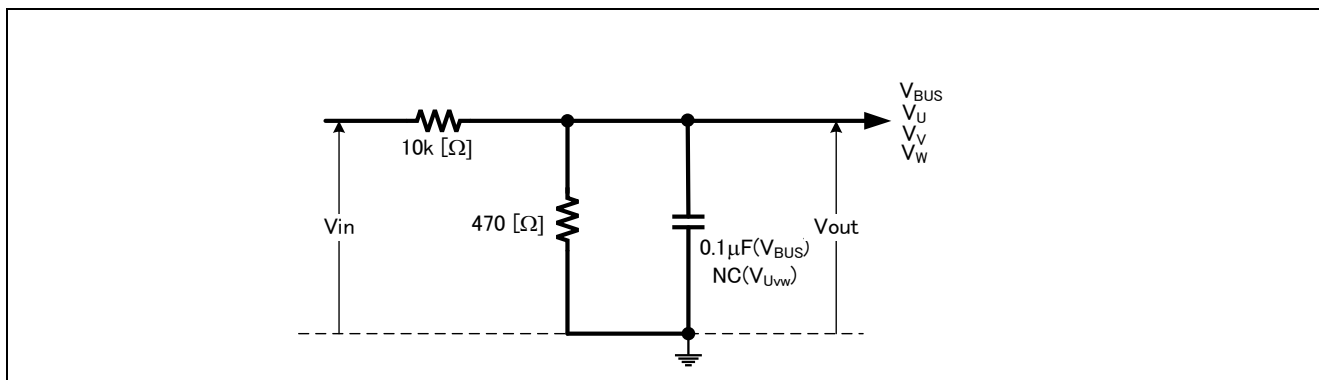

Figure 10-3 Schematic Diagram of Output Voltage Detection Circuit

10.1.4 Voltage Generation Circuit

This board generates the voltage of 12V and 5V from the main power supply (24V).

Table 10.1 Voltage Generation Circuit

Item	Input Voltage (Typ.) [V]	Output Voltage (Typ.) [V]	Output Current (Max.) [A]	Used for:
12V generation	12~50	12	2	<ul style="list-style-type: none"> • 5V generation • Gate driver IC
5V generation	12	5	3	Power supply for MCU

10.1.5 LEDs

This board integrates two LEDs. The user can control the LEDs from the microcontroller.

Table 10.2 LEDs

LED No.	Connector terminal	Pin Signal Level	LED State
LED1	Inverter board: CNA_1 CPU card: CN2_1	High	Off
		Low	On
LED2	Inverter board: CNA_2 CPU card: CN2_2	High	Off
		Low	On

10.1.6 Tact Switch

This board integrates two tact switches: SW1 and SW2. The use can define the behavior of the switches.

Table 10.3 Tact Switch

SW No.	Connector terminal	Pin Signal Level	Switch Setting
SW1	Inverter board: CNA_13 CPU card: CN2_13	High	Off
		Low	On
SW2	Inverter board: CNA_14 CPU card: CN2_14	High	Off
		Low	On

10.1.7 Analog Signal Input Connector

This board integrates connectors for inputting analog signals. **Table 10.4** lists the pin assignment for each connector.

Table 10.4 Analog Signal Input Connectors (Inverter board)

Connector No.	Connector terminal	Pin No.	Pin Function
CN1(ANI1)	Inverter board: CNB_9 CPU card: CN1_9	1	5V
		2	Analog input
CN7(ANI0)	Inverter board: CNB_15 CPU card: CN1_15	1	5V
		2	Analog input

When using these connectors, be sure to connect them to the compatible connector shown in **Table 10.5** below.

Table 10.5 Compatible Connector

Part	Part No.	Manufacturer
Connector	XHP-2	J.S.T. Mfg. Co. Ltd.

Table 10.6 Analog Signal Input Voltage Range

Item	Specification
Input voltage range [V]	0 to AVCC

10.2 CPU card connector

Two 20-pin connectors are provided for connection to the CPU card.

Table 10.7 CPU card connector (CNA)

Pin No.	Output direction	Function
1	Input	LED1
2	Input	LED2
3	-	-
4	-	-
5	-	-
6	-	-
7	Input	PWM Output (W_n)
8	Input	PWM Output (V_n)
9	Input	PWM Output (U_n)
10	Input	PWM Output (W_p)
11	Input	PWM Output (V_p)
12	Input	PWM Output (U_p)
13	Output	SW1
14	Output	SW2
15	Output	+5V
16	Output	+5V
17	-	GND
18	-	GND
19	-	-
20	-	-

Table 10.8 CPU card connector (CNA)

Pin No.	Output direction	Function
1	-	AVCC1
2	-	AVCC2
3	-	-
4	-	-
5	Output	U-phase current
6	Output	V-phase current
7	Output	W-phase current
8	Output	Inverter Voltage
9	Output	Analog voltage
10	Output	U-phase voltage
11	Output	V-phase voltage
12	Output	W-phase voltage
13	-	-
14	Output	PFC current / DC link current
15	Output	analog voltage
16	Output	mid-point voltage
17	-	VCCIO1
18	-	VCCIO1
19	-	GND1
20	-	GND2

11. CPU card specifications

This chapter describes CPU card specifications.

11.1 Circuit Functions

11.1.1 Power Supply

During operation, 5V is supplied from the inverter board. During writing, power should be supplied from the USB connector. Do not connect to the USB except when writing. (Do not perform debugging operation with the inverter running.) Turn off the power supply of the inverter board when it is connected to the inverter board.

11.1.2 On-Chip Debug Function

On-chip debug function via serial communication is provided using USB driver IC. Communication with the RL78 microcontroller is performed via serial communication by dedicated UART using the TOOLTxD and TOOLRxD pins on the RL78 microcontroller. For details, see RL78 Debug Function Using Serial Port (R20AN0632).

11.1.3 LEDs

This board integrates two LEDs. The user can control the LEDs from the microcontroller.

Table 11.1 LEDs

LED No.	Connector terminal	Pin Signal Level	LED State
LED1	Inverter board: CNA_1	High	Off
	CPU card: CN2_1	Low	On
LED2	Inverter board: CNA_2	High	Off
	CPU card: CN2_2	Low	On

11.1.4 Serial Communication Connector

A connector is provided for serial communication connection. Table 10.2 shows the pin assignments for each connector. When performing serial communication using RMW, connect the communication board to the target connector according to the sample software and application note.

Table 11.2 Pin Assignment of Serial Communication Connectors (CPU Card)

Connector No.	Pin No.	Pin Function
CN6 UART0	1	5V
	2	Transmission
	3	Reception
	4	GND
CN7 UART1	1	5V
	2	Transmission
	3	Reception
	4	GND
CN8 UART2	1	5V
	2	Transmission
	3	Reception
	4	GND

When using these connectors, be sure to connect them to the compatible connector shown in **Table 11.3** below.

Table 11.3 Compatible Connector

Part	Part No.	Manufacturer
Connector	XHP-4	J.S.T. Mfg. Co. Ltd.

11.1.5 Hall Sensor Signal Input Connector

This board integrates a connector for Hall sensor signal input. This connector enables the input of the Hall sensor signal from the supplied PMSM. The Hall sensor signal is pulled up to 5 V and then passed through an RC filter before being inputted to the board. **Table 11.4** lists the pin assignment of the Hall sensor signal input connector.

Table 11.4 Pin Assignment of Hall Sensor Signal Input Connector

Connector No.	Pin No.	Pin Function
CN4	1	5V
	2	GND
	3	HU
	4	HV
	5	HW

When using this connector, be sure to connect it to the compatible connector shown in **Table 11.5** below.

Table 11.5 Compatible Connector

Part	Part No.	Manufacturer
Connector	XHP-5	J.S.T. Mfg. Co. Ltd.

11.1.6 Encoder Signal Input Connector

The encoder signal input function can input the encoder signals from the target motor. The encoder signal is pulled up to 5 V and passed through an RC filter before being input to the microcontroller. **Table 11.6** lists the pin assignment of the encoder signal input connector.

Table 11.6 Pin Assignment of Encoder Signal Input Connector

Connector No.	Pin No.	Pin Function
CN3	1	5V
	2	GND
	3	A-phase
	4	B-phase
	5	Z-phase

When using this connector, be sure to connect it to the compatible connector shown in **Table 11.7** below.

Table 11.7 Compatible Connector

Part	Part No.	Manufacturer
Connector	XHP-5	J.S.T. Mfg. Co. Ltd.

11.1.7 Reset Circuit

This board integrates a reset circuit for resetting the microcontroller at power-on reset and external reset. To apply an external reset to the microcontroller, press the tact switch (RESET1).

11.1.8 Inverter board connection connector

Two 20-pin connectors are provided for connection to the inverter board.

Table 11.8 Inverter board connection connector (CN1)

Pin No.	Output direction	Function
1	-	AVCC1
2	-	AVCC2
3	-	-
4	-	-
5	Input	U-phase current
6	Input	V-phase current
7	Input	W-phase current
8	Input	Inverter Voltage
9	Input	Analog voltage
10	Input	U-phase voltage
11	Input	V-phase voltage
12	Input	W-phase voltage
13	-	-
14	Input	PFC current / DC link current
15	Input	analog voltage
16	Input	mid-point voltage
17	-	VCCIO1
18	-	VCCIO1
19	-	GND1
20	-	GND2

Table 11.9 CPU card connector (CN2)

Pin No.	Output direction	Function
1	Input	LED1
2	Input	LED2
3	-	-
4	-	-
5	-	-
6	-	-
7	Input	PWM Output (W_n)
8	Input	PWM Output (V_n)
9	Input	PWM Output (U_n)
10	Input	PWM Output (W_p)
11	Input	PWM Output (V_p)
12	Input	PWM Output (U_p)
13	Output	SW1
14	Output	SW2
15	Output	+5V
16	Output	+5V
17	-	GND
18	-	GND
19	-	-
20	-	-

11.1.9 List of RL78/G24 Pin Functions

Table 11.10 List of RL78/G24 Pin Functions (1/2)

Pin No.	R7F101GLG2DFB Pin Name	Function
1	P120/ANI19/IVCMP0/PGAI0/TRGIDZ	U-phase voltage measurement / Encoder Z-phase input
2	P43	LED2 on/off control
3	P42	LED1 on/off control
4	P41/(TRJIO0)	VRL
5	P40/TOOL0	Debugger data Input/output
6	RESET	System reset input
7	P124	OPEN
8	P123	OPEN
9	P137/INTP0	Cutoff signal input
10	P122/X2	X2
11	P121/X1	X1
12	REGC	REGC
13	Vss	Ground potential for pins
14	EVss0	EVss0
15	Vdd	Positive power supply for pins
16	EVdd0	EVdd0
17	P60	OPEN
18	P61	OPEN
19	P62	OPEN
20	P63/CCD03	nINVERS
21	P31	OPEN
22	P77/ TxD2	Serial communication
23	P76/ RxD2	Serial communication
24	P75/ TRDIOD1	PWM output (U_p)
25	P74/ TRDIOB1	PWM output (U_n)
26	P73/ TRDIOC1	PWM output (V_p)
27	P72/ TRDIOA1	PWM output (W_p)
28	P71/ TRDIOD0	PWM output (V_n)
29	P70/TRDIOB0	PWM output (W_n)
30	P06	DC link current detection (A/D, PGA, CMP)
31	P05	W-phase voltage measurement (CMP1)
32	P30	V-phase voltage measurement (CMP1)
33	P50/ TOOLRxD	Debugger data Input
34	P51/ TOOLTxD	Debugger data output
35	P52/(INTP1)	Hall sensor input (HU)
36	P53/(INTP2)	Hall sensor input (HV)
37	P54/(INTP3)	Hall sensor input (HW)
38	P55	OPEN
39	P17/ ANI27	Analog signal input VR1
40	P16/ANI26	Analog signal input Vy
41	P15	OPEN
42	P14/ ANI24	Analog signal input PFC_G
43	P13/ANI23	Analog signal input Vdc
44	P12/ TxD0_1	Serial communication
45	P11/RxD0_1	Serial communication

Table 11.11 List of RL78/G24 Pin Functions (2/2)

Pin No.	R7F101GLG2DFB Pin Name	Function
46	P10/ANI20	OPEN
47	P146/ANI28	OPEN
48	P147/ANI18/IVCMP3/PGAI3	Analog Signal Input I _{pf} c
49	P27/ANI7	Analog signal input V _{ac}
50	P26/ANI6	Analog signal input V _{dc}
51	P25/ANI5	Analog signal input V _{temp}
52	P24/ANI4	Analog signal input I _v
53	P23/ANI3/PGAGND	Analog signal input I _w / GND
54	P22/ANI2/PGAI4	Analog signal input I _u
55	P21/ANI1/AVREFM	AGND
56	P20/ANI0/AVREFP	AVCC
57	P130	OPEN
58	P04	Tact switch (SW2)
59	P03/RxD1	Serial communication
60	P02/TxD1	Serial communication
61	P01/ANI30/IVCMP2/PGAI2/TRGCLKB	W-phase voltage measurement / Encoder B-phase input (pin shared)
62	P00/ANI29/IVCMP1/PGAI1/TRGCLKA	V-phase voltage measurement / Encoder A-phase input (pin shared)
63	P141	Tact switch (SW1)
64	P140	OPEN

12. Communication Board Functions

This section describes the specifications of the communication board.

12.1 Function

12.1.1 Power Supply

The power of this product is supplied via a USB connector.

12.1.2 USB communication

This product is equipped with a USB type-C connector for communication with a PC when using RMW.

12.2 Serial Communication

This product has two connectors for serial communication connection in order to communicate with the target MCU when using RMW, etc. The pin assignments are shown in **Table 12.1** and **Table 12.2**. When using the communication cable bundled with this product, use CN5.

The serial communication connector and the MCU (RX72N) are connected via a digital isolator, so the communication board and the CPU board with the target MCU are isolated.

Table 12.1 Serial communication connector (CN5) pin assignment

Pin No.	Function	Comment
1	VCC	
2	RXD	Connect to TXD of target MCU
3	TXD	Connect to RXD of target MCU
4	GND	

Table 12.2 Serial communication connector (CN4) pin assignment

Pin No.	Function	Comment
1	VCC	
2	RXD	Connect to TXD of target MCU
3	TXD	Connect to RXD of target MCU
4	GND	

13. Design and Manufacture Information

You can obtain information on the design and manufacture of this product from [renesas.com](https://www.renesas.com).

14. Website and Support

In order to learn, download tools and documents, apply technical support for RL78 family MCU and its kit, visit the following website.

- RL78 Product Information [renesas.com/rl78](https://www.renesas.com/rl78)
- Renesas Support [renesas.com/support](https://www.renesas.com/support)

Revision History

Rev.	Date	Description	
		Page	Summary
1.00	27/11/2023	—	New create

General Precautions in the Handling of Microprocessing Unit and Microcontroller Unit Products

The following usage notes are applicable to all Microprocessing unit and Microcontroller unit products from Renesas. For detailed usage notes on the products covered by this document, refer to the relevant sections of the document as well as any technical updates that have been issued for the products.

1. Precaution against Electrostatic Discharge (ESD)

A strong electrical field, when exposed to a CMOS device, can cause destruction of the gate oxide and ultimately degrade the device operation. Steps must be taken to stop the generation of static electricity as much as possible, and quickly dissipate it when it occurs. Environmental control must be adequate. When it is dry, a humidifier should be used. This is recommended to avoid using insulators that can easily build up static electricity. Semiconductor devices must be stored and transported in an anti-static container, static shielding bag or conductive material. All test and measurement tools including work benches and floors must be grounded. The operator must also be grounded using a wrist strap. Semiconductor devices must not be touched with bare hands. Similar precautions must be taken for printed circuit boards with mounted semiconductor devices.

2. Processing at power-on

The state of the product is undefined at the time when power is supplied. The states of internal circuits in the LSI are indeterminate and the states of register settings and pins are undefined at the time when power is supplied. In a finished product where the reset signal is applied to the external reset pin, the states of pins are not guaranteed from the time when power is supplied until the reset process is completed. In a similar way, the states of pins in a product that is reset by an on-chip power-on reset function are not guaranteed from the time when power is supplied until the power reaches the level at which resetting is specified.

3. Input of signal during power-off state

Do not input signals or an I/O pull-up power supply while the device is powered off. The current injection that results from input of such a signal or I/O pull-up power supply may cause malfunction and the abnormal current that passes in the device at this time may cause degradation of internal elements. Follow the guideline for input signal during power-off state as described in your product documentation.

4. Handling of unused pins

Handle unused pins in accordance with the directions given under handling of unused pins in the manual. The input pins of CMOS products are generally in the high-impedance state. In operation with an unused pin in the open-circuit state, extra electromagnetic noise is induced in the vicinity of the LSI, an associated shoot-through current flows internally, and malfunctions occur due to the false recognition of the pin state as an input signal become possible.

5. Clock signals

After applying a reset, only release the reset line after the operating clock signal becomes stable. When switching the clock signal during program execution, wait until the target clock signal is stabilized. When the clock signal is generated with an external resonator or from an external oscillator during a reset, ensure that the reset line is only released after full stabilization of the clock signal. Additionally, when switching to a clock signal produced with an external resonator or by an external oscillator while program execution is in progress, wait until the target clock signal is stable.

6. Voltage application waveform at input pin

Waveform distortion due to input noise or a reflected wave may cause malfunction. If the input of the CMOS device stays in the area between V_{IL} (Max.) and V_{IH} (Min.) due to noise, for example, the device may malfunction. Take care to prevent chattering noise from entering the device when the input level is fixed, and also in the transition period when the input level passes through the area between V_{IL} (Max.) and V_{IH} (Min.).

7. Prohibition of access to reserved addresses

Access to reserved addresses is prohibited. The reserved addresses are provided for possible future expansion of functions. Do not access these addresses as the correct operation of the LSI is not guaranteed.

8. Differences between products

Before changing from one product to another, for example to a product with a different part number, confirm that the change will not lead to problems. The characteristics of a microprocessing unit or microcontroller unit products in the same group but having a different part number might differ in terms of internal memory capacity, layout pattern, and other factors, which can affect the ranges of electrical characteristics, such as characteristic values, operating margins, immunity to noise, and amount of radiated noise. When changing to a product with a different part number, implement a system-evaluation test for the given product.

Notice

1. Descriptions of circuits, software and other related information in this document are provided only to illustrate the operation of semiconductor products and application examples. You are fully responsible for the incorporation or any other use of the circuits, software, and information in the design of your product or system. Renesas Electronics disclaims any and all liability for any losses and damages incurred by you or third parties arising from the use of these circuits, software, or information.
2. Renesas Electronics hereby expressly disclaims any warranties against and liability for infringement or any other claims involving patents, copyrights, or other intellectual property rights of third parties, by or arising from the use of Renesas Electronics products or technical information described in this document, including but not limited to, the product data, drawings, charts, programs, algorithms, and application examples.
3. No license, express, implied or otherwise, is granted hereby under any patents, copyrights or other intellectual property rights of Renesas Electronics or others.
4. You shall be responsible for determining what licenses are required from any third parties, and obtaining such licenses for the lawful import, export, manufacture, sales, utilization, distribution or other disposal of any products incorporating Renesas Electronics products, if required.
5. You shall not alter, modify, copy, or reverse engineer any Renesas Electronics product, whether in whole or in part. Renesas Electronics disclaims any and all liability for any losses or damages incurred by you or third parties arising from such alteration, modification, copying or reverse engineering.
6. Renesas Electronics products are classified according to the following two quality grades: "Standard" and "High Quality". The intended applications for each Renesas Electronics product depends on the product's quality grade, as indicated below.

"Standard": Computers; office equipment; communications equipment; test and measurement equipment; audio and visual equipment; home electronic appliances; machine tools; personal electronic equipment; industrial robots; etc.

"High Quality": Transportation equipment (automobiles, trains, ships, etc.); traffic control (traffic lights); large-scale communication equipment; key financial terminal systems; safety control equipment; etc.

Unless expressly designated as a high reliability product or a product for harsh environments in a Renesas Electronics data sheet or other Renesas Electronics document, Renesas Electronics products are not intended or authorized for use in products or systems that may pose a direct threat to human life or bodily injury (artificial life support devices or systems; surgical implantations; etc.), or may cause serious property damage (space system; undersea repeaters; nuclear power control systems; aircraft control systems; key plant systems; military equipment; etc.). Renesas Electronics disclaims any and all liability for any damages or losses incurred by you or any third parties arising from the use of any Renesas Electronics product that is inconsistent with any Renesas Electronics data sheet, user's manual or other Renesas Electronics document.
7. No semiconductor product is absolutely secure. Notwithstanding any security measures or features that may be implemented in Renesas Electronics hardware or software products, Renesas Electronics shall have absolutely no liability arising out of any vulnerability or security breach, including but not limited to any unauthorized access to or use of a Renesas Electronics product or a system that uses a Renesas Electronics product. RENESAS ELECTRONICS DOES NOT WARRANT OR GUARANTEE THAT RENESAS ELECTRONICS PRODUCTS, OR ANY SYSTEMS CREATED USING RENESAS ELECTRONICS PRODUCTS WILL BE INVULNERABLE OR FREE FROM CORRUPTION, ATTACK, VIRUSES, INTERFERENCE, HACKING, DATA LOSS OR THEFT, OR OTHER SECURITY INTRUSION ("Vulnerability Issues"). RENESAS ELECTRONICS DISCLAIMS ANY AND ALL RESPONSIBILITY OR LIABILITY ARISING FROM OR RELATED TO ANY VULNERABILITY ISSUES. FURTHERMORE, TO THE EXTENT PERMITTED BY APPLICABLE LAW, RENESAS ELECTRONICS DISCLAIMS ANY AND ALL WARRANTIES, EXPRESS OR IMPLIED, WITH RESPECT TO THIS DOCUMENT AND ANY RELATED OR ACCOMPANYING SOFTWARE OR HARDWARE, INCLUDING BUT NOT LIMITED TO THE IMPLIED WARRANTIES OF MERCHANTABILITY, OR FITNESS FOR A PARTICULAR PURPOSE.
8. When using Renesas Electronics products, refer to the latest product information (data sheets, user's manuals, application notes, "General Notes for Handling and Using Semiconductor Devices" in the reliability handbook, etc.), and ensure that usage conditions are within the ranges specified by Renesas Electronics with respect to maximum ratings, operating power supply voltage range, heat dissipation characteristics, installation, etc. Renesas Electronics disclaims any and all liability for any malfunctions, failure or accident arising out of the use of Renesas Electronics products outside of such specified ranges.
9. Although Renesas Electronics endeavors to improve the quality and reliability of Renesas Electronics products, semiconductor products have specific characteristics, such as the occurrence of failure at a certain rate and malfunctions under certain use conditions. Unless designated as a high reliability product or a product for harsh environments in a Renesas Electronics data sheet or other Renesas Electronics document, Renesas Electronics products are not subject to radiation resistance design. You are responsible for implementing safety measures to guard against the possibility of bodily injury, injury or damage caused by fire, and/or danger to the public in the event of a failure or malfunction of Renesas Electronics products, such as safety design for hardware and software, including but not limited to redundancy, fire control and malfunction prevention, appropriate treatment for aging degradation or any other appropriate measures. Because the evaluation of microcomputer software alone is very difficult and impractical, you are responsible for evaluating the safety of the final products or systems manufactured by you.
10. Please contact a Renesas Electronics sales office for details as to environmental matters such as the environmental compatibility of each Renesas Electronics product. You are responsible for carefully and sufficiently investigating applicable laws and regulations that regulate the inclusion or use of controlled substances, including without limitation, the EU RoHS Directive, and using Renesas Electronics products in compliance with all these applicable laws and regulations. Renesas Electronics disclaims any and all liability for damages or losses occurring as a result of your noncompliance with applicable laws and regulations.
11. Renesas Electronics products and technologies shall not be used for or incorporated into any products or systems whose manufacture, use, or sale is prohibited under any applicable domestic or foreign laws or regulations. You shall comply with any applicable export control laws and regulations promulgated and administered by the governments of any countries asserting jurisdiction over the parties or transactions.
12. It is the responsibility of the buyer or distributor of Renesas Electronics products, or any other party who distributes, disposes of, or otherwise sells or transfers the product to a third party, to notify such third party in advance of the contents and conditions set forth in this document.
13. This document shall not be reprinted, reproduced or duplicated in any form, in whole or in part, without prior written consent of Renesas Electronics.
14. Please contact a Renesas Electronics sales office if you have any questions regarding the information contained in this document or Renesas Electronics products.

(Note1) "Renesas Electronics" as used in this document means Renesas Electronics Corporation and also includes its directly or indirectly controlled subsidiaries.

(Note2) "Renesas Electronics product(s)" means any product developed or manufactured by or for Renesas Electronics.

(Rev.5.0-1 October 2020)

Corporate Headquarters

TOYOSU FORESIA, 3-2-24 Toyosu,
Koto-ku, Tokyo 135-0061, Japan
www.renesas.com

Trademarks

Renesas and the Renesas logo are trademarks of Renesas Electronics Corporation. All trademarks and registered trademarks are the property of their respective owners.

Contact information

For further information on a product, technology, the most up-to-date version of a document, or your nearest sales office, please visit:
www.renesas.com/contact/.

X-ON Electronics

Largest Supplier of Electrical and Electronic Components

Click to view similar products for [Power Management IC Development Tools](#) category:

Click to view products by [Renesas](#) manufacturer:

Other Similar products are found below :

[EVB-EP5348UI](#) [BQ25010EVM](#) [ISL80019AEVAL1Z](#) [ISLUSBI2CKIT1Z](#) [ISL8002AEVAL1Z](#) [ISL91108IIA-EVZ](#) [MAX8556EVKIT](#)
[MAX15005AEVKIT+](#) [ISL28022EVKIT1Z](#) [STEVAL-ISA008V1](#) [DRI0043](#) [KITPF8100FRDMEVM](#) [EVB-EN6337QA](#)
[SAMPLEBOXILD8150TOBO1](#) [MAX18066EVKIT#](#) [AP62300WU-EVM](#) [KITA2GTC387MOTORCTRTOBO1](#) [AEK-MOT-TK200G1](#)
[EVLONE65W](#) [STEVAL-ILH006V1](#) [STEVAL-IPE008V2](#) [STEVAL-IPP001V2](#) [STEVAL-ISA013V1](#) [STEVAL-ISA067V1](#) [STEVAL-](#)
[ISQ002V1](#) [TPS2306EVM-001](#) [TPS2330EVM-185](#) [TPS40001EVM-001](#) [SECO-HVDCDC1362-15W-GEVB](#) [BTS7030-2EPA](#)
[LT8638SJV#WPBF](#) [LTC3308AIV#WTRPBF](#) [TLT807B0EPV](#) [BTS71033-6ESA](#) [EV13N91A](#) [EASYPIC V8 OVER USB-C](#) [EV55W64A](#)
[CLICKER 4 FOR STM32F4](#) [EASYMX PRO V7A FOR STM32](#) [CLICKER 4 FOR PIC18F](#) [Si8285_86v2-KIT](#) [PAC52700EVK1](#) [NCP-](#)
[NCV51752D2PAK3LGEVB](#) [ISL81807EVAL1Z](#) [AP33772S-EVB](#) [EVALM7HVIGBTFCINV4TOBO1](#) [903-0300-000](#) [902-0173-000](#) [903-](#)
[0301-000](#) [ROA1286023/1](#)