

R9A02G011

R19AN0054EJ0100

Rev.1.0

RTK-251-1PowerBank3 Instruction Manual

Nov 9, 2018

Introduction

The RTK-251-1PowerBank3 is a 3cell (series connected) Li-ion battery power bank reference board having one USB Type-C™ port. The USB Type-C port supports the Dual Role Power (DRP) Feature. When the power bank is in Sink mode, the power bank requests 5, 9, 15, 20V which is supported by a USB Power Delivery (USB PD) provider such as a USB PD AC adapter. When the power bank is in Source mode, as long as an installed battery has enough power budget, it will supply 5, 9, 12, 15, 20V which is requested by a USB PD consumer product such as a Tablet, PC, or smartphone.

The RTK-251-1PowerBank3 works as DRP device and automatically detects Power provider such as a USB PD AC adapter and Power consumer such as a Tablet, PC, and smartphone that is connected to this board. Also, it changes own power role depending on the remaining battery capacities. The battery remaining capacities are always displayed on LEDs.

The RTK-251-1PowerBank3 board is USB-IF PD3.0 certified and the functions and capabilities are fixed in the setting at that time.

Target Device

USB Power Delivery Controller (PDC): R9A02G011

Buck-Boost Battery Charger (BB-Charger): ISL95538B

Contents

1. Features	3
1.1 USB-IF PD3.0 certified configurations	5
2. Functions	6
2.1 Battery charging.....	6
2.2 LED function.....	7
2.3 Protection functions	8
3. Board Setup and how to use	9
3.1 Required materials to use this board.....	9
3.2 Board settings	10
3.3 Battery power connection	11
3.3.1 Operation example of Source mode.	11
3.3.2 Operation example of Sink mode.....	12
4. Optional functions	13

1. Features

The RTK-251-1PowerBank3 supports the following features.

- USB Power Delivery and USB Type-C
 - Having one USB Type-C port
 - Power Role: Dual Role (Supports Try.SRC mode)
 - Power Source voltage (no PPS): 5, 9, 12, 15, 20V
 - Power Sink: 5, 9, 15, 20V
- Battery Charger
 - Battery type: Li-ion battery.
 - Number of cells: 3series cells
 - Trickle Charging
- 5 LED indicators
 - USB Type-C port status indicator (1 LED)
 - Battery remaining capacity indicator (4 LEDs)
- Protections
 - Over Temperature Protection (USB Type-C Receptacle)
 - Over Voltage Protection (VBUS voltage)
 - Over Current Protection (VBUS current)

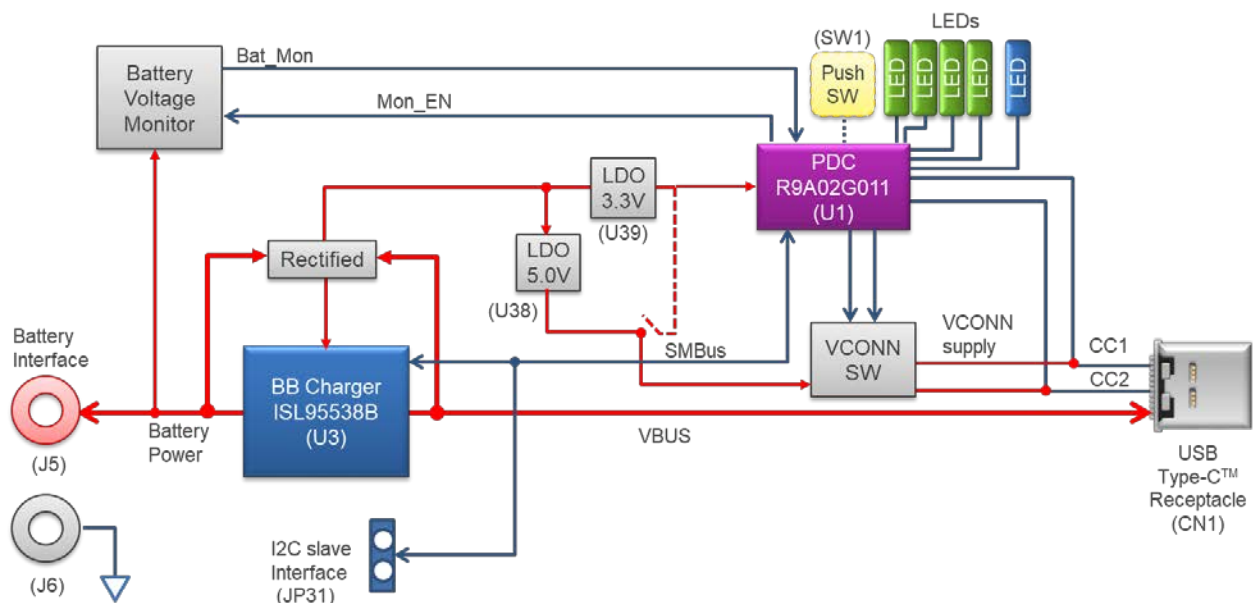

Figure 1-1 RTK-251-1PowerBank3 Block Diagram

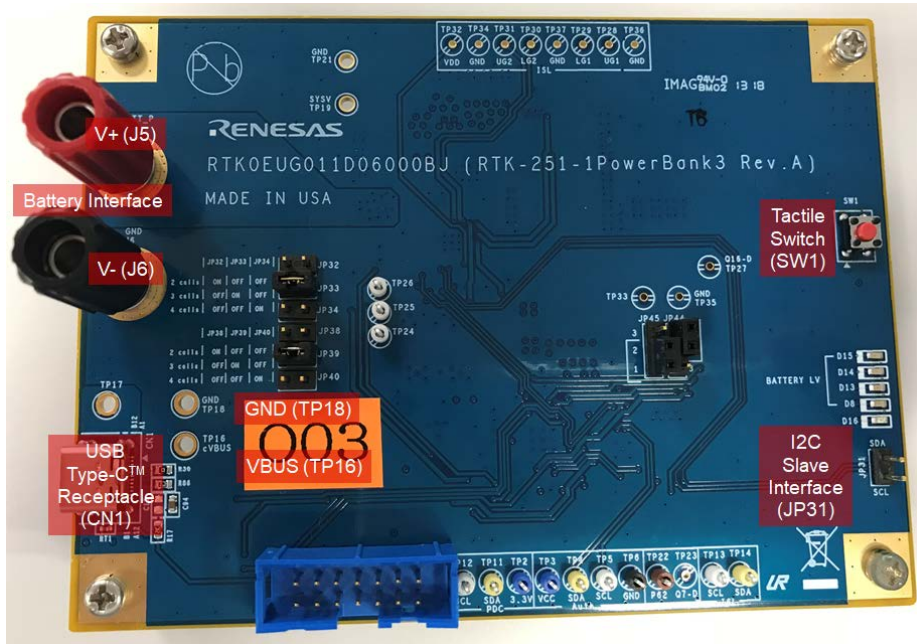

Figure 1-2 RTK-251-1PowerBank3 Board picture (Top View)

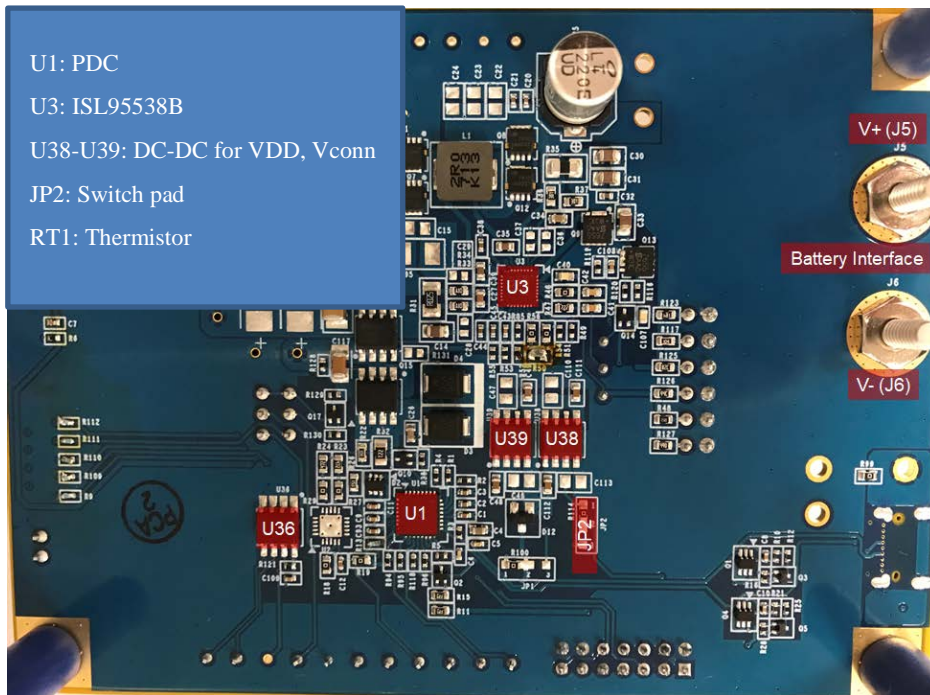

Figure 1-3 RTK-251-1PowerBank3 Board picture (Bottom View)

1.1 USB-IF PD3.0 certified configurations

The RTK-251-1PowerBank3 board is USB-IF PD3.0 certified under the following configurations.

Category: Power Brick (no PPS)

Product Name: RTK-251-1PowerBank3

TID: 1090007

- Power Role: Dual Role (Supports Try.SRC)
 - 45W Power Source: 5, 9, 12, 15, 20V
 - 60W Power Sink: 5, 9, 15, 20V
- Supports BC1.2 DCP

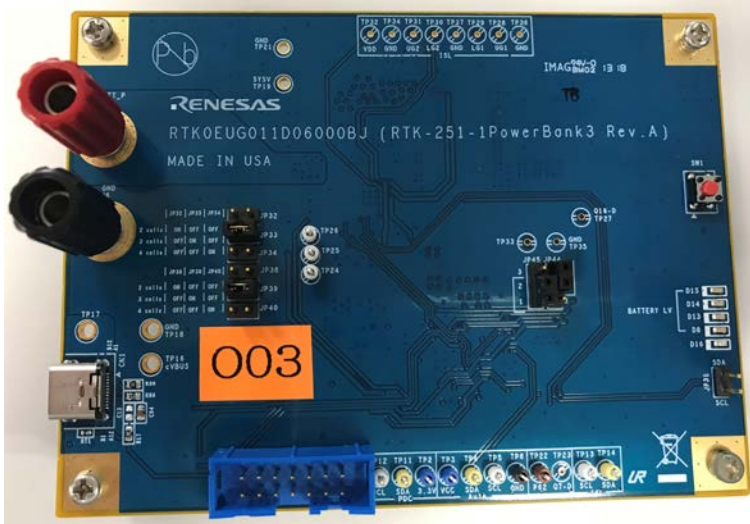

2. Functions

The RTK-251-1PowerBank3 board functions are described in this section.

2.1 Battery charging

The RTK-251-1PowerBank3 manages Battery Charging. It starts to charge the battery with charging current and stops charging when the battery charging current is less than 200mA for 200ms in CV loop. The RTK-251-1PowerBank3 restarts charging when the battery voltage is decreased below "Max Voltage". The RTK-251-1PowerBank3 also supports trickle charging to an overly discharged battery. It can activate the trickle charging function when the battery voltage is lower than "Min Voltage". "Max Voltage" and "Min Voltage" are pre-programmed in PDC firmware.

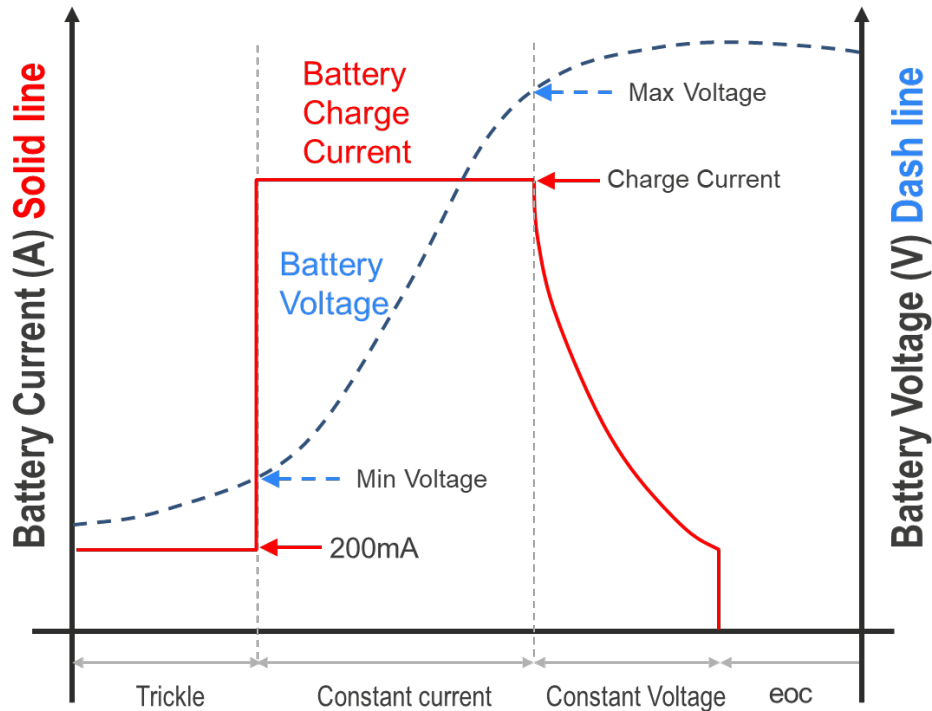

Figure 2-1 Battery Charging Image.

2.2 LED function

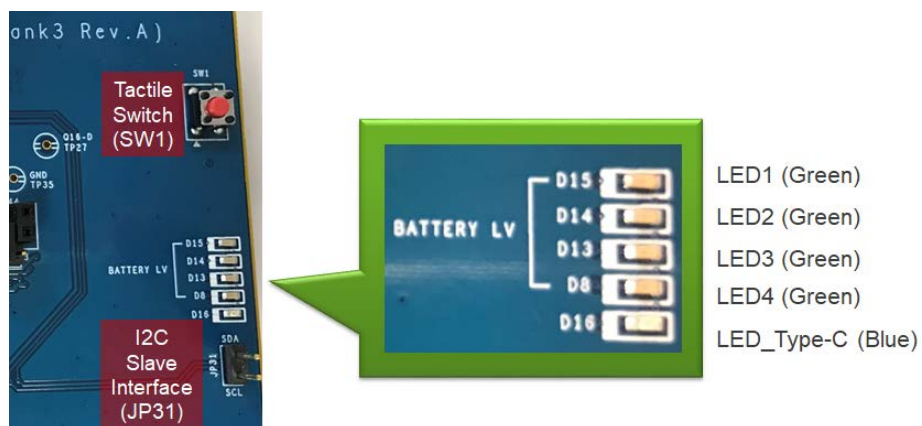

Figure 2-2 LEDs on RTK-251-1PowerBank3.

USB Type-C port role	LED_Type-C behavior
Unplugged	OFF
Sink mode	Blinking (0.5 sec interval as default)
Sink mode (Fully-charged)	OFF
Source mode	Lighted
Source mode (Low Battery)	OFF

Table 2-1 USB Type-C Port role indicator (Blue LED: D16)

Under charging RTK-251-1PowerBank3 from USB PD source device				
Battery power	LED1	LED2	LED3	LED4
Low Battery - 0 %	OFF	OFF	OFF	OFF
0 % - 30 %	OFF	OFF	OFF	OFF
30 % - 45 %	Lighted	OFF	OFF	OFF
45 % - 60 %	Lighted	Lighted	OFF	OFF
60 % -	Lighted	Lighted	Lighted	OFF
Fully-charged	Lighted	Lighted	Lighted	Lighted

Table 2-2 Battery remaining capacity indicator (Green LED: D15, D14, D13, D8)

Under discharging RTK-251-1PowerBank3 to other battery device or Unplugged				
Battery power	LED1	LED2	LED3	LED4
Low Battery - 0 %	OFF	OFF	OFF	OFF
0 % - 30 %	Lighted	OFF	OFF	OFF
30 % - 45 %	Lighted	Lighted	OFF	OFF
45 % - 60 %	Lighted	Lighted	Lighted	OFF
60 % -	Lighted	Lighted	Lighted	Lighted
Fully-charged	Lighted	Lighted	Lighted	Lighted

Table 2-3 Battery remaining capacity indicator (Green LED: D15, D14, D13, D8)

2.3 Protection functions

The RTK-251-1PowerBank3 supports the protection functions.

Parameter	Description	Threshold value
OCP	When VBUS current is over 3.2A, ISL95538B will stop VBUS. Then PDC detect VBUS drop as OCP.	Fixed
OVP	Over voltage protection value. Send Hard Reset command to source when VBUS voltage is reaching the OVP value.	25V
OTP	Over temperature protection value. For details, please refer to R9A02G011 User Manual.	Safe: 40 degrees C Warning: 60 degrees C Danger: 80 degrees C

3. Board Setup and how to use

Prior to start using the board, please make sure if the jumpers settings are the same as the following instructions. Also, please don't try other settings, which all are reserved.

3.1 Required materials to use this board.

- 3 cells Li-ion battery pack **having a battery protection function**, the battery emulator or the two/four-quadrant DC power supply: 1 unit
- USB Type-C Cable: 1pcs

Caution:

Please use this board when you understand and agree that Renesas DOES NOT have any responsibility, indemnification, or liability for use of this board. Especially, Li-ion batteries may cause fire, injury, explosion, etc. if they are handled incorrectly. Please use the charge / discharge of the battery at your own risk.

Item	Condition / Note	Specification
Nominal Voltage	Average	10.8V
Standard Charge	Constant current	Greater than 2000mA
Maximum Charge Voltage		12.6V
Standard Discharge	Cut off voltage	Lower than 8.25V
	Constant current	Greater than 6000mA
Operating Temperature	Charge	0 ~ 45 degrees C at least.
	Discharge	-20 ~ 60 degrees C at least.

Table 3-1 Requirements for 3 cells battery pack to be used.

3.2 Board settings

The Jumper settings of RTK-251-1PowerBank3 board is described in this section. Other settings are reserved and please DO NOT change them.

Caution:

Make sure the HW setting matches the battery pack configuration. Li-ion batteries may cause fire, injury, explosion, etc. if this HW setting is different from an actual battery configuration.



Figure 3-1 JP32/JP33/JP34/JP38/JP39/JP40 jumpers on RTK-251-1PowerBank3.

	JP32	JP33	JP34	JP38	JP39	JP40
3 cells	OFF	ON	OFF	OFF	ON	OFF

Table 3-2 JP32/33/34/38/39/40 settings.

JP2 (Switch Pad)	R114 mounted on 1-2 side
------------------	--------------------------

Table 3-3 JP2 setting.

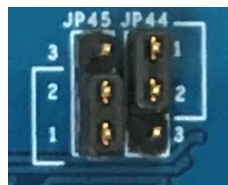

Figure 3-2 JP44/JP45 jumpers on RTK-251-1PowerBank3.

JP44	JP45
Connected 1 and 2	Connected 1 and 2

Table 3-4 JP44/JP45 setting

3.3 Battery power connection

Figure 3-3 shows the battery power connection to RTK-251-1PowerBank3 board.

- Battery V+ should be connected to J5 (Red Banana Jack)
- Battery V- should be connected to J6 (Black Banana Jack)

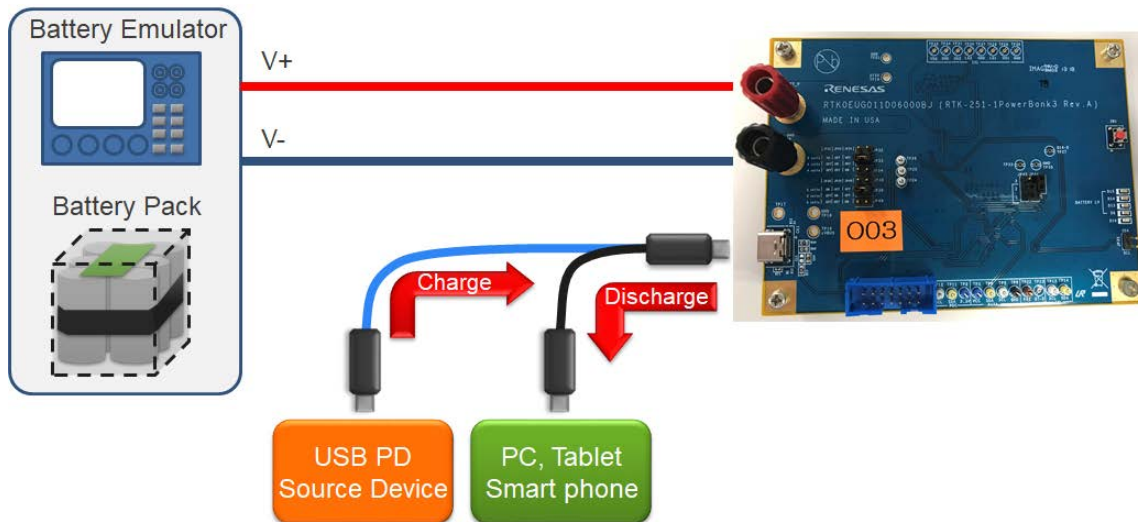

Figure 3-3 Battery power and USB device connection.

After installing the battery power, RTK-251-1PowerBank3 is ready to use.

3.3.1 Operation example of Source mode.

Figure 3-4 shows the connection example of charging device using RTK-251-1PowerBank3 board.

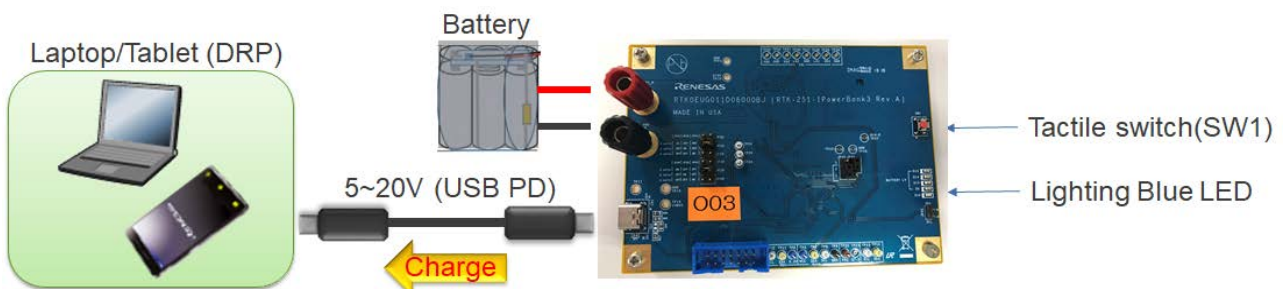

Figure 3-4 connection configuration of source mode.

When connecting a PD device to RTK-251-1PowerBank3 board via Type-C cable, RTK-251-1PowerBank3 detects it and tries to be in Source mode so that power can be charged to an attached device as much as possible. If the RTK-251-1PowerBank3 is in source mode, Lighting blue LED on RTK-251-1PowerBank3 and charging VBUS to an attached device.

The RTK-251-1PowerBank3 does not operate as Source device when the power role of connected device is Source only or RTK-251-1PowerBank3 is in the low battery status.

The RTK-251-1PowerBank3 operates only as Sink device when the Battery Level falls below the Low Battery Detection Threshold. And Source operations resumes when the Battery Level exceeds the Low Battery Detection Threshold.

3.3.2 Operation example of Sink mode.

Figure 3-5 shows the connection example of charging RTK-251-1PowerBank3 using PD source device.

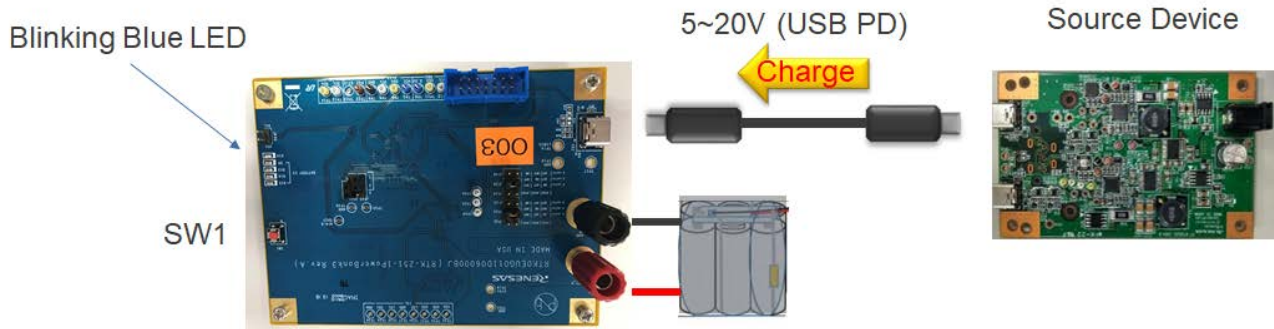

Figure 3-5 connection configuration of sink mode.

When the RTK-251-1PowerBank3 is connected to Source only device such as USB PD AC adapter via USB Type-C cable, it automatically detects the device and always becomes Sink mode. If the RTK-251-1PowerBank3 is connected to the Legacy USB downstream port using USB A to C cable, RTK-251-1PowerBank3 also becomes Sink mode automatically by detecting VBUS power.

When DRP device is connected, the RTK-251-1PowerBank3 tries to become Source mode as much as possible. If RTK-251-1PowerBank3 detects the low battery status, RTK-251-1PowerBank3 is fixed to Sink mode until battery is charged enough. When RTK-251-1PowerBank3 is in Sink mode, LED (Blue) is blinking.

4. Optional functions

The RTK-251-1PowerBank3 board is not possible to change parameters by using the Renesas ROM Image Generator. The RTK-251-1PowerBank3 supports any other optional functions as following. They are disabled in this kit. For changes in these functions, please contact Renesas local sales offices.

- Customize USB Type-C output power (Up to 60W PDP^{Note}, supported optional capabilities such as 12V or 14.8V, supported PPS)
- Customize Battery power (Number of cells, Battery capabilities)
- Customize LED behavior
- Switch function
- Deep Sleep mode

Note: Maximum PDP is depended on Battery power.

Website and Support

Renesas Electronics Website

<http://www.renesas.com/>

Inquiries

<http://www.renesas.com/contact/>

All trademarks and registered trademarks are the property of their respective owners.

Revision History

Rev.	Date	Description	
		Page	Summary
1.0	Nov 9, 2018	—	Initial Release

General Precautions in the Handling of Microprocessing Unit and Microcontroller Unit Products

The following usage notes are applicable to all Microprocessing unit and Microcontroller unit products from Renesas. For detailed usage notes on the products covered by this document, refer to the relevant sections of the document as well as any technical updates that have been issued for the products.

1. Handling of Unused Pins

Handle unused pins in accordance with the directions given under Handling of Unused Pins in the manual.

- The input pins of CMOS products are generally in the high-impedance state. In operation with an unused pin in the open-circuit state, extra electromagnetic noise is induced in the vicinity of LSI, and an associated shoot-through current flows internally; malfunctions can occur due to the false recognition of the pin state as an input signal. Unused pins should be handled as described under Handling of Unused Pins in the manual.

2. Processing at Power-on

The state of the product is undefined at the moment when power is supplied.

- The states of internal circuits in the LSI are indeterminate and the states of register settings and pins are undefined at the moment when power is supplied.

In a finished product where the reset signal is applied to the external reset pin, the states of pins are not guaranteed from the moment when power is supplied until the reset process is completed.

In a similar way, the states of pins in a product that is reset by an on-chip power-on reset function are not guaranteed from the moment when power is supplied until the power reaches the level at which resetting has been specified.

3. Prohibition of Access to Reserved Addresses

Access to reserved addresses is prohibited.

- The reserved addresses are provided for the possible future expansion of functions. Do not access these addresses; the correct operation of LSI is not guaranteed if they are accessed.

4. Clock Signals

After applying a reset, only release the reset line after the operating clock signal has become stable. When switching the clock signal during program execution, wait until the target clock signal has stabilized.

- When the clock signal is generated with an external resonator (or from an external oscillator) during a reset, ensure that the reset line is only released after full stabilization of the clock signal. Moreover, when switching to a clock signal produced with an external resonator (or by an external oscillator) while program execution is in progress, wait until the target clock signal is stable.

5. Differences between Products

Before changing from one product to another, i.e. to a product with a different part number, confirm that the change will not lead to problems.

- The characteristics of Microprocessing unit or Microcontroller unit products in the same group but having a different part number may differ in terms of the internal memory capacity, layout pattern, and other factors, which can affect the ranges of electrical characteristics, such as characteristic values, operating margins, immunity to noise, and amount of radiated noise. When changing to a product with a different part number, implement a system-evaluation test for the given product.

Notice

1. Descriptions of circuits, software and other related information in this document are provided only to illustrate the operation of semiconductor products and application examples. You are fully responsible for the incorporation or any other use of the circuits, software, and information in the design of your product or system. Renesas Electronics disclaims any and all liability for any losses and damages incurred by you or third parties arising from the use of these circuits, software, or information.
 2. Renesas Electronics hereby expressly disclaims any warranties against and liability for infringement or any other claims involving patents, copyrights, or other intellectual property rights of third parties, by or arising from the use of Renesas Electronics products or technical information described in this document, including but not limited to, the product data, drawings, charts, programs, algorithms, and application examples.
 3. No license, express, implied or otherwise, is granted hereby under any patents, copyrights or other intellectual property rights of Renesas Electronics or others.
 4. You shall not alter, modify, copy, or reverse engineer any Renesas Electronics product, whether in whole or in part. Renesas Electronics disclaims any and all liability for any losses or damages incurred by you or third parties arising from such alteration, modification, copying or reverse engineering.
 5. Renesas Electronics products are classified according to the following two quality grades: "Standard" and "High Quality". The intended applications for each Renesas Electronics product depends on the product's quality grade, as indicated below.
"Standard": Computers; office equipment; communications equipment; test and measurement equipment; audio and visual equipment; home electronic appliances; machine tools; personal electronic equipment; industrial robots; etc.
"High Quality": Transportation equipment (automobiles, trains, ships, etc.); traffic control (traffic lights); large-scale communication equipment; key financial terminal systems; safety control equipment; etc.
Unless expressly designated as a high reliability product or a product for harsh environments in a Renesas Electronics data sheet or other Renesas Electronics document, Renesas Electronics products are not intended or authorized for use in products or systems that may pose a direct threat to human life or bodily injury (artificial life support devices or systems; surgical implantations; etc.), or may cause serious property damage (space system; undersea repeaters; nuclear power control systems; aircraft control systems; key plant systems; military equipment; etc.). Renesas Electronics disclaims any and all liability for any damages or losses incurred by you or any third parties arising from the use of any Renesas Electronics product that is inconsistent with any Renesas Electronics data sheet, user's manual or other Renesas Electronics document.
 6. When using Renesas Electronics products, refer to the latest product information (data sheets, user's manuals, application notes, "General Notes for Handling and Using Semiconductor Devices" in the reliability handbook, etc.), and ensure that usage conditions are within the ranges specified by Renesas Electronics with respect to maximum ratings, operating power supply voltage range, heat dissipation characteristics, installation, etc. Renesas Electronics disclaims any and all liability for any malfunctions, failure or accident arising out of the use of Renesas Electronics products outside of such specified ranges.
 7. Although Renesas Electronics endeavors to improve the quality and reliability of Renesas Electronics products, semiconductor products have specific characteristics, such as the occurrence of failure at a certain rate and malfunctions under certain use conditions. Unless designated as a high reliability product or a product for harsh environments in a Renesas Electronics data sheet or other Renesas Electronics document, Renesas Electronics products are not subject to radiation resistance design. You are responsible for implementing safety measures to guard against the possibility of bodily injury, injury or damage caused by fire, and/or danger to the public in the event of a failure or malfunction of Renesas Electronics products, such as safety design for hardware and software, including but not limited to redundancy, fire control and malfunction prevention, appropriate treatment for aging degradation or any other appropriate measures. Because the evaluation of microcomputer software alone is very difficult and impractical, you are responsible for evaluating the safety of the final products or systems manufactured by you.
 8. Please contact a Renesas Electronics sales office for details as to environmental matters such as the environmental compatibility of each Renesas Electronics product. You are responsible for carefully and sufficiently investigating applicable laws and regulations that regulate the inclusion or use of controlled substances, including without limitation, the EU RoHS Directive, and using Renesas Electronics products in compliance with all these applicable laws and regulations. Renesas Electronics disclaims any and all liability for damages or losses occurring as a result of your noncompliance with applicable laws and regulations.
 9. Renesas Electronics products and technologies shall not be used for or incorporated into any products or systems whose manufacture, use, or sale is prohibited under any applicable domestic or foreign laws or regulations. You shall comply with any applicable export control laws and regulations promulgated and administered by the governments of any countries asserting jurisdiction over the parties or transactions.
 10. It is the responsibility of the buyer or distributor of Renesas Electronics products, or any other party who distributes, disposes of, or otherwise sells or transfers the product to a third party, to notify such third party in advance of the contents and conditions set forth in this document.
 11. This document shall not be reprinted, reproduced or duplicated in any form, in whole or in part, without prior written consent of Renesas Electronics.
 12. Please contact a Renesas Electronics sales office if you have any questions regarding the information contained in this document or Renesas Electronics products.
- (Note 1) "Renesas Electronics" as used in this document means Renesas Electronics Corporation and also includes its directly or indirectly controlled subsidiaries.
(Note 2) "Renesas Electronics product(s)" means any product developed or manufactured by or for Renesas Electronics.

(Rev.4.0-1 November 2017)



SALES OFFICES

Renesas Electronics Corporation

<http://www.renesas.com>

Refer to "<http://www.renesas.com/>" for the latest and detailed information.

Renesas Electronics Corporation

TOYOSU FORESIA, 3-2-24 Toyosu, Koto-ku, Tokyo 135-0061, Japan

Renesas Electronics America Inc.

1001 Murphy Ranch Road, Milpitas, CA 95035, U.S.A.
Tel: +1-408-432-8888, Fax: +1-408-434-5351

Renesas Electronics Canada Limited

9251 Yonge Street, Suite 8309 Richmond Hill, Ontario Canada L4C 9T3
Tel: +1-905-237-2004

Renesas Electronics Europe Limited

Dukes Meadow, Millboard Road, Bourne End, Buckinghamshire, SL8 5FH, U.K.
Tel: +44-1628-651-700

Renesas Electronics Europe GmbH

Arcadiastrasse 10, 40472 Düsseldorf, Germany
Tel: +49-211-6503-0, Fax: +49-211-6503-1327

Renesas Electronics (China) Co., Ltd.

Room 1709 Quantum Plaza, No.27 ZhichunLu, Haidian District, Beijing, 100191 P. R. China
Tel: +86-10-8235-1155, Fax: +86-10-8235-7679

Renesas Electronics (Shanghai) Co., Ltd.

Unit 301, Tower A, Central Towers, 555 Langao Road, Putuo District, Shanghai, 200333 P. R. China
Tel: +86-21-2226-0888, Fax: +86-21-2226-0999

Renesas Electronics Hong Kong Limited

Unit 1601-1611, 16/F., Tower 2, Grand Century Place, 193 Prince Edward Road West, Mongkok, Kowloon, Hong Kong
Tel: +852-2265-6688, Fax: +852 2886-9022

Renesas Electronics Taiwan Co., Ltd.

13F, No. 363, Fu Shing North Road, Taipei 10543, Taiwan
Tel: +886-2-8175-9600, Fax: +886 2-8175-9670

Renesas Electronics Singapore Pte. Ltd.

80 Bendemeer Road, Unit #06-02 Hyflux Innovation Centre, Singapore 339949
Tel: +65-6213-0200, Fax: +65-6213-0300

Renesas Electronics Malaysia Sdn.Bhd.

Unit 1207, Block B, Menara Amcorp, Amcorp Trade Centre, No. 18, Jln Persiaran Barat, 46050 Petaling Jaya, Selangor Darul Ehsan, Malaysia
Tel: +60-3-7955-9390, Fax: +60-3-7955-9510

Renesas Electronics India Pvt. Ltd.

No.777C, 100 Feet Road, HAL 2nd Stage, Indiranagar, Bangalore 560 038, India
Tel: +91-80-67208700, Fax: +91-80-67208777

Renesas Electronics Korea Co., Ltd.

17F, KAMCO Yangjae Tower, 262, Gangnam-daero, Gangnam-gu, Seoul, 06265 Korea
Tel: +82-2-558-3737, Fax: +82-2-558-5338

X-ON Electronics

Largest Supplier of Electrical and Electronic Components

Click to view similar products for [Power Management IC Development Tools](#) category:

Click to view products by [Renesas](#) manufacturer:

Other Similar products are found below :

[EVAL-ADM1168LQEBZ](#) [EVB-EP5348UI](#) [MIC23451-AAAYFL EV](#) [MIC5281YMME EV](#) [DA9063-EVAL](#) [ADP122-3.3-EVALZ](#) [ADP130-0.8-EVALZ](#) [ADP130-1.2-EVALZ](#) [ADP130-1.5-EVALZ](#) [ADP130-1.8-EVALZ](#) [ADP1714-3.3-EVALZ](#) [ADP1716-2.5-EVALZ](#) [ADP1740-1.5-EVALZ](#) [ADP1752-1.5-EVALZ](#) [ADP1828LC-EVALZ](#) [ADP1870-0.3-EVALZ](#) [ADP1871-0.6-EVALZ](#) [ADP1873-0.6-EVALZ](#) [ADP1874-0.3-EVALZ](#) [ADP1882-1.0-EVALZ](#) [ADP199CB-EVALZ](#) [ADP2102-1.25-EVALZ](#) [ADP2102-1.875EVALZ](#) [ADP2102-1.8-EVALZ](#) [ADP2102-2-EVALZ](#) [ADP2102-3-EVALZ](#) [ADP2102-4-EVALZ](#) [ADP2106-1.8-EVALZ](#) [ADP2147CB-110EVALZ](#) [AS3606-DB](#) [BQ24010EVM](#) [BQ24075TEVM](#) [BQ24155EVM](#) [BQ24157EVM-697](#) [BQ24160EVM-742](#) [BQ24296MEVM-655](#) [BQ25010EVM](#) [BQ3055EVM](#) [NCV891330PD50GEVB](#) [ISLUSBI2CKIT1Z](#) [LM2744EVAL](#) [LM2854EVAL](#) [LM3658SD-AEV/NOPB](#) [LM3658SDEV/NOPB](#) [LM3691TL-1.8EV/NOPB](#) [LM4510SDEV/NOPB](#) [LM5033SD-EVAL](#) [LP38512TS-1.8EV](#) [EVAL-ADM1186-1MBZ](#) [EVAL-ADM1186-2MBZ](#)