

# Target Board Kit S5D5 (TB-S5D5)

User's Manual

Renesas Synergy™ Platform  
Synergy Tools & Kits  
Kits: TB-S5D5 v1.0

All information contained in these materials, including products and product specifications, represents information on the product at the time of publication and is subject to change by Renesas Electronics Corp. without notice. Please review the latest information published by Renesas Electronics Corp. through various means, including the Renesas Electronics Corp. website (<http://www.renesas.com>).

## Notice

1. Descriptions of circuits, software and other related information in this document are provided only to illustrate the operation of semiconductor products and application examples. You are fully responsible for the incorporation or any other use of the circuits, software, and information in the design of your product or system. Renesas Electronics disclaims any and all liability for any losses and damages incurred by you or third parties arising from the use of these circuits, software, or information.
  2. Renesas Electronics hereby expressly disclaims any warranties against and liability for infringement or any other claims involving patents, copyrights, or other intellectual property rights of third parties, by or arising from the use of Renesas Electronics products or technical information described in this document, including but not limited to, the product data, drawings, charts, programs, algorithms, and application examples.
  3. No license, express, implied or otherwise, is granted hereby under any patents, copyrights or other intellectual property rights of Renesas Electronics or others.
  4. You shall not alter, modify, copy, or reverse engineer any Renesas Electronics product, whether in whole or in part. Renesas Electronics disclaims any and all liability for any losses or damages incurred by you or third parties arising from such alteration, modification, copying or reverse engineering.
  5. Renesas Electronics products are classified according to the following two quality grades: "Standard" and "High Quality". The intended applications for each Renesas Electronics product depends on the product's quality grade, as indicated below.
    - "Standard": Computers; office equipment; communications equipment; test and measurement equipment; audio and visual equipment; home electronic appliances; machine tools; personal electronic equipment; industrial robots; etc.
    - "High Quality": Transportation equipment (automobiles, trains, ships, etc.); traffic control (traffic lights); large-scale communication equipment; key financial terminal systems; safety control equipment; etc.
- Unless expressly designated as a high reliability product or a product for harsh environments in a Renesas Electronics data sheet or other Renesas Electronics document, Renesas Electronics products are not intended or authorized for use in products or systems that may pose a direct threat to human life or bodily injury (artificial life support devices or systems; surgical implantations; etc.), or may cause serious property damage (space system; undersea repeaters; nuclear power control systems; aircraft control systems; key plant systems; military equipment; etc.). Renesas Electronics disclaims any and all liability for any damages or losses incurred by you or any third parties arising from the use of any Renesas Electronics product that is inconsistent with any Renesas Electronics data sheet, user's manual or other Renesas Electronics document.
6. When using Renesas Electronics products, refer to the latest product information (data sheets, user's manuals, application notes, "General Notes for Handling and Using Semiconductor Devices" in the reliability handbook, etc.), and ensure that usage conditions are within the ranges specified by Renesas Electronics with respect to maximum ratings, operating power supply voltage range, heat dissipation characteristics, installation, etc. Renesas Electronics disclaims any and all liability for any malfunctions, failure or accident arising out of the use of Renesas Electronics products outside of such specified ranges.
  7. Although Renesas Electronics endeavors to improve the quality and reliability of Renesas Electronics products, semiconductor products have specific characteristics, such as the occurrence of failure at a certain rate and malfunctions under certain use conditions. Unless designated as a high reliability product or a product for harsh environments in a Renesas Electronics data sheet or other Renesas Electronics document, Renesas Electronics products are not subject to radiation resistance design. You are responsible for implementing safety measures to guard against the possibility of bodily injury, injury or damage caused by fire, and/or danger to the public in the event of a failure or malfunction of Renesas Electronics products, such as safety design for hardware and software, including but not limited to redundancy, fire control and malfunction prevention, appropriate treatment for aging degradation or any other appropriate measures. Because the evaluation of microcomputer software alone is very difficult and impractical, you are responsible for evaluating the safety of the final products or systems manufactured by you.
  8. Please contact a Renesas Electronics sales office for details as to environmental matters such as the environmental compatibility of each Renesas Electronics product. You are responsible for carefully and sufficiently investigating applicable laws and regulations that regulate the inclusion or use of controlled substances, including without limitation, the EU RoHS Directive, and using Renesas Electronics products in compliance with all these applicable laws and regulations. Renesas Electronics disclaims any and all liability for damages or losses occurring as a result of your noncompliance with applicable laws and regulations.
  9. Renesas Electronics products and technologies shall not be used for or incorporated into any products or systems whose manufacture, use, or sale is prohibited under any applicable domestic or foreign laws or regulations. You shall comply with any applicable export control laws and regulations promulgated and administered by the governments of any countries asserting jurisdiction over the parties or transactions.
  10. It is the responsibility of the buyer or distributor of Renesas Electronics products, or any other party who distributes, disposes of, or otherwise sells or transfers the product to a third party, to notify such third party in advance of the contents and conditions set forth in this document.
  11. This document shall not be reprinted, reproduced or duplicated in any form, in whole or in part, without prior written consent of Renesas Electronics.
  12. Please contact a Renesas Electronics sales office if you have any questions regarding the information contained in this document or Renesas Electronics products.

(Note1) "Renesas Electronics" as used in this document means Renesas Electronics Corporation and also includes its directly or indirectly controlled subsidiaries.

(Note2) "Renesas Electronics product(s)" means any product developed or manufactured by or for Renesas Electronics.

(Rev.4.0-1 November 2017)

## Corporate Headquarters

TOYOSU FORESIA, 3-2-24 Toyosu,  
Koto-ku, Tokyo 135-0061, Japan  
[www.renesas.com](http://www.renesas.com)

## Trademarks

Renesas and the Renesas logo are trademarks of Renesas Electronics Corporation. All trademarks and registered trademarks are the property of their respective owners.

## Contact information

For further information on a product, technology, the most up-to-date version of a document, or your nearest sales office, please visit:  
[www.renesas.com/contact/](http://www.renesas.com/contact/).

## Renesas Synergy™ Target Board Kit S5D5 (TB-S5D5) Disclaimer

By using this TB-S5D5, the user accepts the following terms, which are in addition to, and control in the event of disagreement, with Renesas' General Terms and Conditions available at <https://www.renesas.com/en-us/legal/disclaimer.html>.

The TB-S5D5 is not guaranteed to be error free, and the entire risk as to the results and performance of the TB-S5D5 is assumed by the User. The TB-S5D5 is provided by Renesas on an "as is" basis without warranty of any kind whether express or implied, including but not limited to the implied warranties of satisfactory quality, fitness for a particular purpose, title, and non-infringement of intellectual property rights with regard to the TB-S5D5. Renesas expressly disclaims all such warranties.

Renesas does not consider the TB-S5D5 a finished product and therefore the TB-S5D5 may not yet comply with some requirements applicable to finished products, including, but not limited to recycling (WEEE), CE, UL, restricted substances (ROHS), FCC, FEE, and electromagnetic compatibility regulations. Renesas or its affiliates shall in no event be liable for any loss of profit, loss of data, loss of contract, loss of business, damage to reputation or goodwill, any economic loss, any reprogramming or recall costs (whether the foregoing losses are direct or indirect) nor shall Renesas or its affiliates be liable for any other direct or indirect special, incidental or consequential damages arising out of or in relation to the use of this TB-S5D5, even if Renesas or its affiliates have been advised of the possibility of such damages.

Renesas has used reasonable care in preparing the information included in this document, but Renesas does not warrant that such information is error free nor does Renesas guarantee an exact match for every application or parameter to part numbers designated by other vendors listed herein. The information provided in this document is intended solely to enable the use of Renesas products. No express or implied license to any intellectual property right is granted by this document or in connection with the sale of Renesas products. Renesas reserves the right to make changes to specifications and product descriptions at any time without notice. Renesas assumes no liability for any damages incurred by you resulting from errors in or omissions from the information included herein. Renesas cannot verify, and assumes no liability for, the accuracy of information available on another company's website.

## Precautions

This Renesas Synergy™ Target Board Kit is only intended for use in a laboratory environment under ambient temperature and humidity conditions. A safe separation distance should be used between this and any sensitive equipment. Its use outside the laboratory, classroom, study area, or similar such area invalidates conformity with the protection requirements of the Electromagnetic Compatibility Directive and could lead to prosecution.

The product generates, uses, and can radiate radio frequency energy and may cause harmful interference to radio communications. There is no guarantee that interference will not occur in a particular installation. If this equipment causes harmful interference to radio or television reception, which can be determined by turning the equipment off or on, you are encouraged to try to correct the interference by one or more of the following measures:

- Ensure attached cables do not lie across the equipment.
- Reorient the receiving antenna.
- Increase the distance between the equipment and the receiver.
- Connect the equipment into an outlet on a circuit different from that which the receiver is connected.
- Power down the equipment when not in use.
- Consult the dealer or an experienced radio/TV technician for help.

Note: It is recommended that wherever possible shielded interface cables are used.

The product is potentially susceptible to certain EMC phenomena. To mitigate against them it is recommended that the following measures be undertaken:

- The user is advised that mobile phones should not be used within 10 m of the product when in use.
- The user is advised to take ESD precautions when handling the equipment.

The Renesas Synergy™ Target Board Kit does not represent an ideal reference design for an end product and does not fulfill the regulatory standards for an end product.

## Renesas Synergy™ Platform

**Target Board Kit S5D5 (TB-S5D5)****Contents**

1. Overview .....	3
2. Kit Contents.....	6
3. Getting Started with Embedded Application Development on TB-S5D5.....	6
4. TB-S5D5 Hardware Details .....	7
4.1 Jumpers and DIP Switch Settings.....	7
4.1.1 Copper Jumpers.....	7
4.1.2 Default Board Configuration.....	7
5. Hardware Layout .....	9
5.1 System Block Diagram .....	9
5.2 Power Requirements.....	10
5.2.1 Power Supply Options.....	10
5.2.1.1 Option 1: Debug USB (Default).....	10
5.2.1.2 Option 2: Test Points TP3 and TP4 .....	10
5.2.1.3 Option 3: Test Points TP1 and TP2 .....	11
5.2.1.4 Option 4: Pin Headers.....	11
5.2.2 Powering up the Board.....	12
5.2.3 Battery Supply Configuration .....	12
5.2.4 Measuring Current Consumption .....	12
5.3 Main Components .....	14
5.4 Connectivity and Settings.....	15
5.4.1 Device USB .....	15
5.4.2 Debug USB .....	16
5.4.3 JTAG/SWD.....	16
5.4.4 LEDs.....	17
5.4.5 Switches .....	17
5.4.6 PMOD A .....	19
5.4.7 PMOD B .....	19
5.4.8 User Capacitive Touch Button .....	20
5.5 Pin Headers.....	21
5.5.1 Pin Header J1.....	22
5.5.2 Pin Header J2.....	23
5.5.3 Pin Header J3.....	23
5.5.4 Pin Header J4.....	24

---

5.6	Additional Features .....	25
5.6.1	Analog Reference Voltages .....	25
5.6.2	On-Board Clock Crystals .....	25
5.6.3	User Potentiometer .....	25
5.6.4	Boot Configuration.....	26
5.6.5	Miscellaneous Signals.....	27
5.6.5.1	AVCC0/AVSS0.....	27
5.6.5.2	VCL .....	27
5.6.5.3	Ext VCL0 and VCL0 Cap .....	27
5.6.5.4	VCC_USB .....	27
5.6.5.5	Signal P205.....	27
6.	Certifications.....	28
6.1	EMC/EMI Standards.....	28
6.2	Material Selection, Waste, Recycling and Disposal Standards .....	28
6.3	Safety Standards .....	28
7.	Design and Manufacturing Information .....	29
	Website and Support .....	29
	Revision History.....	30

## 1. Overview

The Target Board Kit S5D5 (TB-S5D5) enables developers to get started with initial firmware development and evaluation of the Synergy Software Package (SSP) on the S5D3 MCU Group.

- Renesas Synergy™ S5D5 Microcontroller Group
  - R7FS5D57C3A01CFB
  - 144-pin Low Profile Quad Flat Pack (LQFP) package
  - 120 MHz Arm® Cortex®-M4 core with Floating Point Unit (FPU)
  - 384 KB SRAM
  - 1 MB code flash memory
  - 32 KB data flash memory
- Connectivity
  - A Device USB connector for the Main MCU
  - SEGGER J-Link® On-Board (OB) interface for debugging and programming of the S5D5 MCU. A 10-pin JTAG/SWD interface is also provided for connecting optional external debuggers and programmers.
  - Two PMOD connectors, allowing use of appropriate PMOD compliant peripheral plug-in modules for rapid prototyping
  - Pin headers for access to power and signals for the Main MCU
- Multiple clock sources
  - Main MCU oscillator crystals, providing precision 12.000 MHz and 32,768 Hz reference clocks
  - Additional low-precision clocks are available internal to the Main MCU
- MCU reset push-button switch
- MCU boot configuration jumper
- General purpose I/O ports
  - One jumper to allow measuring of Main MCU current
  - Copper jumpers on PCB bottom side for configuration and access to selected MCU signals
- Operating voltage
  - External 5V input through the Debug USB connector supplies the on-board power regulator to power the Target Board logic and interfaces. Alternatively, 5 V or 3.3 V may be supplied through alternate locations on the Target Board.
- A two-color board status LED indicating availability of regulated power and connection status of the J-Link interface
- A red User LED, controlled by the Main MCU firmware
- A User Push-Button switch, User Capacitive Touch Sensor (button), and an optional User Potentiometer, all are controlled by the Main MCU firmware

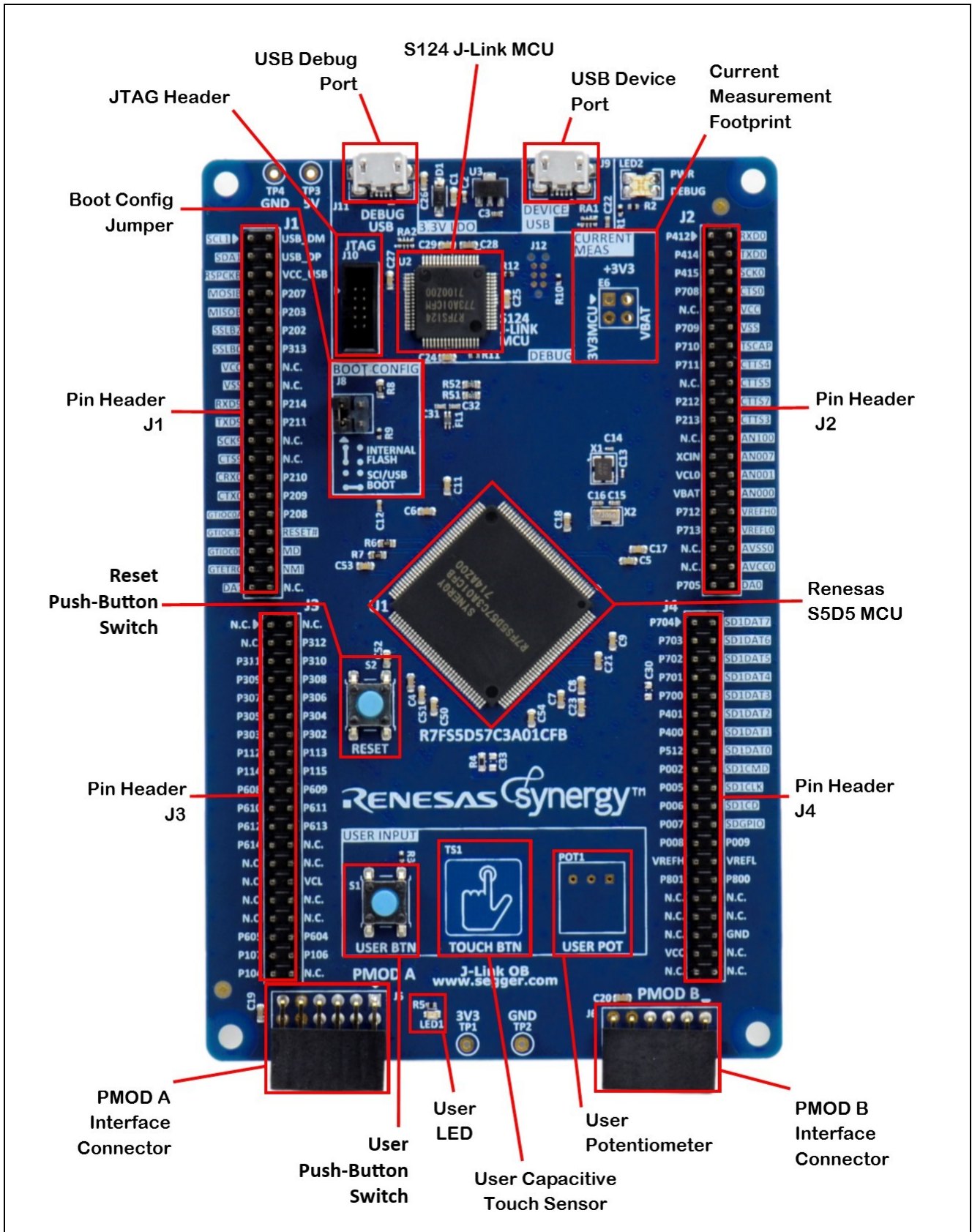

Figure 1. TB-S5D5 Top Side



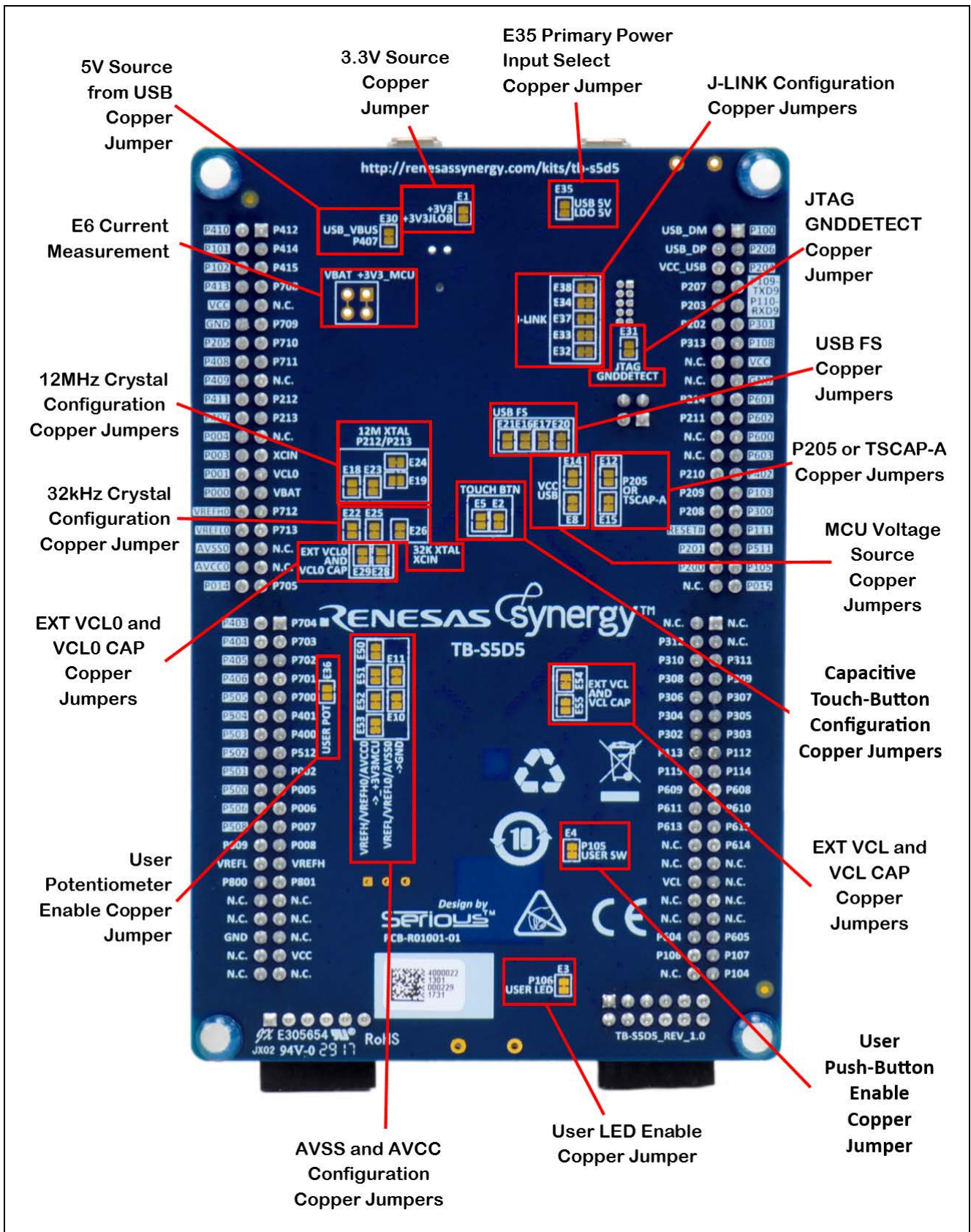

Figure 2. TB-S5D5 Bottom Side



## 2. Kit Contents

The following components are included in the Target Board Kit S5D5 (TB-S5D5):

- 1x TB-S5D5 board
- 1x USB Type-A to Micro-B cable

## 3. Getting Started with Embedded Application Development on TB-S5D5

To develop and execute embedded applications on the TB-S5D5 using the Synergy Platform, Synergy Software Package and development tools are required to be installed on your computer.

### Step 1: Create My Renesas Account (if you do not have one already)

You need a **My Renesas** account to download software, development tools, and application projects. Log in to or Sign up for a **My Renesas** account at [www.update.renesas.com/SSO/login](http://www.update.renesas.com/SSO/login).

### Step 2: Download and Install Synergy Software Package and Development Tools

The Synergy Software Package, J-Link USB drivers, and one of the two supported tool chains are bundled and available as single downloadable file as follows:

- IAR Platform Installer** installs Synergy Software Package and IAR Embedded Workbench® for Renesas Synergy™ IDE with IAR compiler and J-Link USB drivers.  
Download from [www.renesas.com/synergy/ewsynergy](http://www.renesas.com/synergy/ewsynergy).
- e<sup>2</sup> studio Platform Installer** installs Synergy Software Package and e<sup>2</sup> studio for Synergy IDE with IAR compiler and J-Link USB drivers.  
Download from [www.renesas.com/synergy/e2studio](http://www.renesas.com/synergy/e2studio).

Note: The TB-S5D5 uses J-Link® On-board (OB) debug interface. While J-Link drivers are necessary to establish debug connection between the host PC and the TB-S5D5, they are not required to run the Out-of-Box (OoB) Demonstration (Blinky) Application that the TB-S5D5 comes pre-programmed with. Refer to the *TB-S5D5 Quick Start Guide* for more details.

### Step 3: Explore Existing Application Projects for the TB-S5D5

Renesas provides several application projects to demonstrate different capabilities of the S5D5 MCU Group. These application projects can also serve as a good starting point for you to develop your custom applications. Application projects available for the TB-S5D5 are listed at <http://www.renesas.com/synergy/tb-s5d5>.

- Notes:
1. Every application project includes the project files, an application note, and instructions to import the application project.
  2. On downloading the application project from the website to your computer, the application projects have to be built using one of the two supported tool chains before they can be downloaded on to the TB-S5D5 board.

## 4. TB-S5D5 Hardware Details

### 4.1 Jumpers and DIP Switch Settings

#### 4.1.1 Copper Jumpers

There are two types of copper jumpers, designated **trace-cut** and **solder-bridge**.

A **trace-cut jumper** is provided with a narrow copper trace connecting its pads. The silk screen overlay printing around a trace-cut jumper is a solid box. To isolate the pads, cut the trace between pads adjacent to each pad then remove the connecting copper foil either mechanically or with the assistance of heat. Once the etched copper trace is removed, the trace-cut jumper is turned into a solder-bridge jumper for any later changes.

A **solder-bridge jumper** is provided with two isolated pads that may be joined together by one of three methods:

- Solder may be applied to both pads to develop a bulge on each and the bulges joined by touching a soldering iron across the two pads.
- A small wire may be placed across the two pads and soldered in place.
- A SMT resistor, size 0805, 0603, or 0402, may be placed across the two pads and soldered in place. A zero-ohm resistor shorts the pads together.

The silk screen overlay printing around a solder-bridge jumper is a box with a gap in the lines adjacent to the isolation region between the pads.

For any copper jumper, the connection is considered **closed** if there is an electrical connection between the pads (default for trace-cut jumpers). The connection is considered **open** if there is no electrical connection between the pads (default for the solder-bridge jumpers).

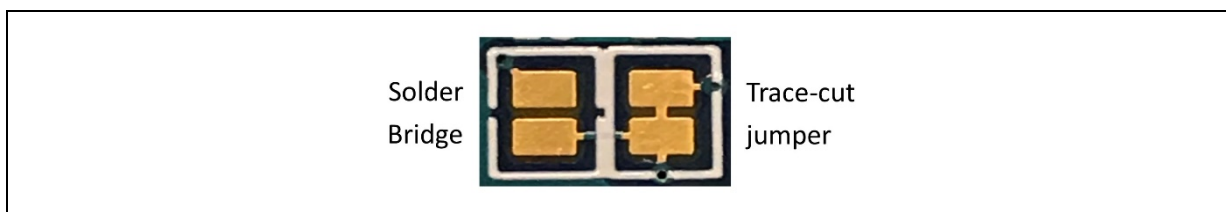

Figure 3. Copper Jumpers

#### 4.1.2 Default Board Configuration

The following table describes the default settings for each jumper on the TB-S5D5. This includes traditional pin jumpers (Jx designation) and copper jumpers (Ex designation).

The Circuit Group for each jumper is the designation found in the board schematic. Functional details for many of the listed jumpers may be found in section 5.4, Connectivity and Settings and section 5.6, Additional Features.

Table 1. Default Jumper Settings

Location	Circuit Group	Default Open/Closed	Function
J8	MCU Mode Config	Jumper on pins 1-2	Sets the MCU Mode to boot from Internal Flash
E18	12M XTAL	Open	Connects signal P213 to MCU
E19		Open	Connects signal P212 to MCU
E23		Closed	Connects 12.000 MHz Crystal to MCU
E24		Closed	Connects 12.000 MHz Crystal to MCU
E1	3.3 V Linear Regulator	Closed	Alternate 3.3V source (+3V3JLOB)
E22	32K XTAL	Open	Connects signal P215 to MCU
E25		Closed	Connects 32.768 kHz Crystal to MCU
E26		Closed	Connects 32.768 kHz Crystal to MCU
E2	Capacitive Touch-Button	Closed	Enable/Disable Capacitive Touch-Button
E5		Open	Connects signal P115J to Capacitive Touch-Button

Location	Circuit Group	Default Open/Closed	Function	
E54	EXT VCL and VCL CAP	Closed	Connects MCU VCL to a capacitor	
E55		Open	Connects MCU VCL to the VCL signal	
E28	EXT VCL0 and VCL0 CAP	Open	Connects VCL to MCU	
E29		Closed	Connects MCU pin 15 (VCL) to capacitor	
E32	J-Link	Closed	Connects the S124 J-LINK MCU to the J-Link signal JLED	
E33		Closed	Connects the S124 J-LINK MCU to the J-Link signal RESET#	
E34		Closed	Connects the S124 J-LINK MCU to the J-Link signal TDO(/SWO) P109	
E37		Closed	Connects the S124 J-LINK MCU to the J-Link signal P108/SWDIO	
E38		Closed	Connects the S124 J-LINK MCU to the J-Link signal P300/SWCLK	
E35		J-Link® OB USB	Closed	Connects the J-Link OB USB 5V input to the primary 5V->3.3V voltage regulator
E31	JTAG Connector	Open	JTAG Ground Detect. Connects the JTAG connector pin 9 to Ground.	
E13	LDO and VCC USB	Open	Connects VCC_USB_LDO to MCU pin 41	
E7		Closed	Connects +3V3MCU to MCU pin 41	
E10	MCU VREF	Closed	Connects AVCC0 to +3V3MCU	
E11		Closed	Connects AVSS0 to Ground	
E50		Closed	Connects VREFH0 to +3V3MCU	
E51		Closed	Connects VREFL0 to Ground	
E52		Closed	Connects VREFH to +3V3MCU	
E53		Closed	Connects VREFL to Ground	
E12		P205 or TSCAP-A	Open	Connects MCU pin 43 to signal P205
E15			Closed	Connects MCU pin 43 to capacitor
E30	USB Device Interface	Closed	Connects the Device USB 5V input to the MCU	
E16	USB FS	Closed	Connects MCU pin 38 to signal USB_N	
E17		Closed	Connects MCU pin 39 to signal USB_P	
E20		Open	Connects MCU pin 39 to signal USBPH_P	
E21		Open	Connects MCU pin 38 to signal USBPH_N	
E3		User LED	Closed	Enable/Disable User LED
E36	User Potentiometer	Open	Enable/Disable User Potentiometer	
E4	User Push-Button	Closed	Enable/Disable User Push-Button switch	
E6	VBAT +3V3_MCU	Closed	Dual Jumper. Pins 1-3 connect +3V3 to +3V3MCU. Pins 2-4 connect +3V3 to VBAT.	
E14	VCC USB	Open	Connects VCC_USB to MCU pin 40	
E8		Closed	Connects +3V3MCU to MCU pin 40	

## 5. Hardware Layout

### 5.1 System Block Diagram

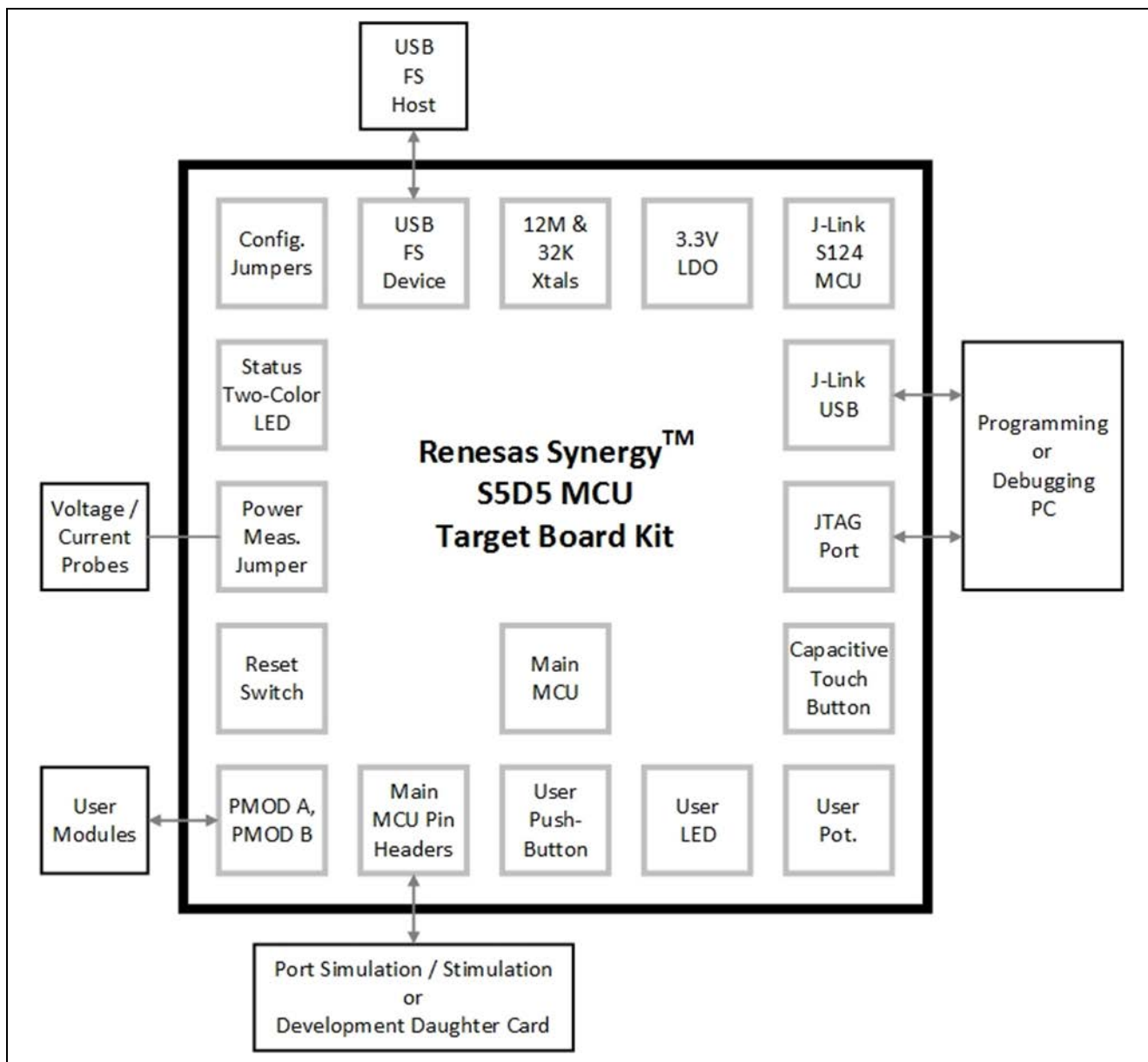

Figure 4. TB-S5D5 Block Diagram

## 5.2 Power Requirements

TB-S5D5 is designed for 3.3 V operation. This also means that 5 V PMOD devices cannot be used together with the TB-S5D5 unless they are powered separately.

The total current available from the LDO regulator for all connected circuits is 600 mA or less, depending on the 5 V power source used.

### 5.2.1 Power Supply Options

TB-S5D5 can be powered in several different ways as described in this section.

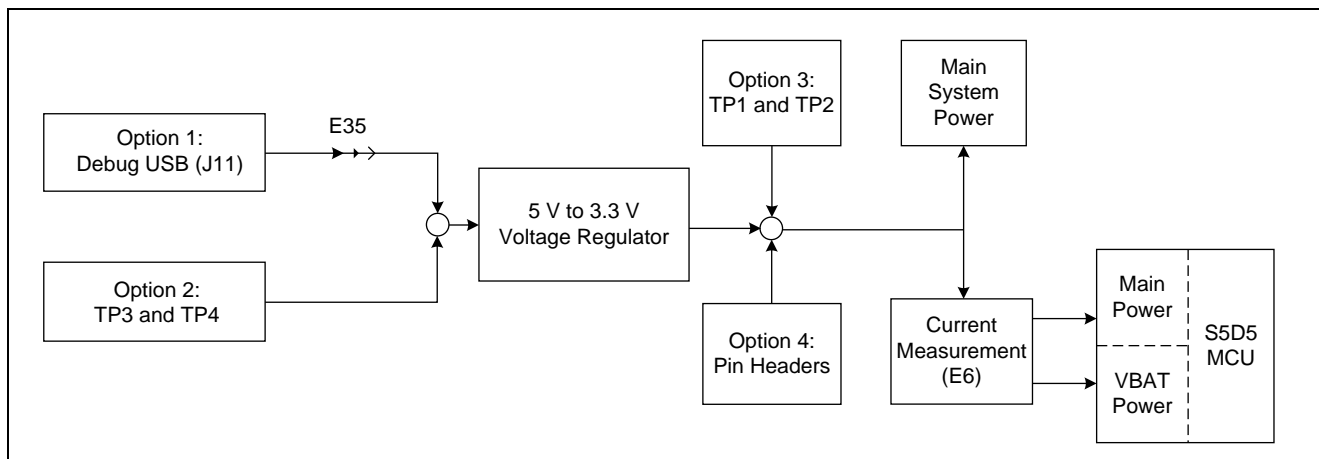
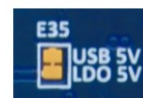

Figure 5. Power Supply Options

#### 5.2.1.1 Option 1: Debug USB (Default)

The default power source is 5 V, supplied from an external USB host to the USB Debug connector labelled **DEBUG USB** on the top surface of the board. A low drop-out regulator (LDO) is used to convert the 5 V signal to 3.3 V, which then is used to power the MCU and any connected devices.

Copper jumper E35 selects the source for the primary power input to the LDO regulator. By default, this jumper is configured to provide power through the Debug USB connector. Copper jumper E35 is closed for this configuration.



#### 5.2.1.2 Option 2: Test Points TP3 and TP4

The TB-S5D5 board can also be powered by installing a 5 V power source across TP3 (positive input) and TP4 (negative input). Copper jumper E35 must be opened to enable powering the board using these test points.

**⚠ The on-board Low Dropout Regulator (see section 5.3, Main Components) has an input voltage range of +3.3 V to +5.5 V, and a built-in current limit of 600 mA. Make sure that any external power source connected to TP3 and TP4 meets these requirements.**

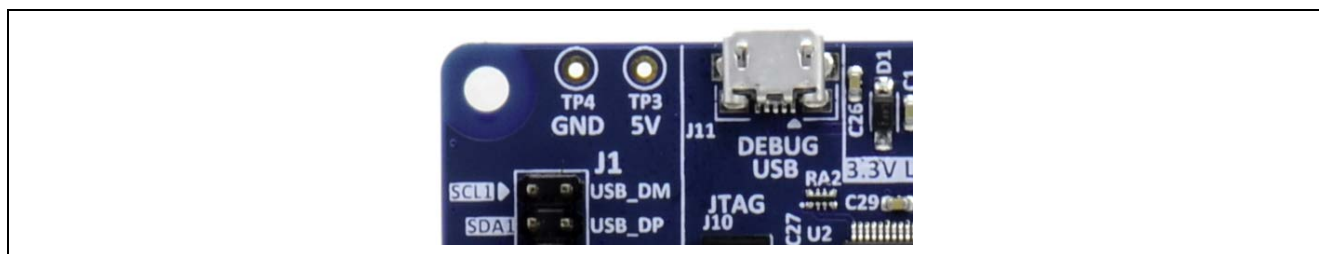

Figure 6. USB Debug Connector (J11), TP3, and TP4 on the Target Board



### 5.2.1.3 Option 3: Test Points TP1 and TP2

The TB-S5D5 board can also be powered by installing a 3.3 V source across TP1 (positive input) and TP2 (negative input). Copper jumper E35 must be open to enable powering the board using these test points.

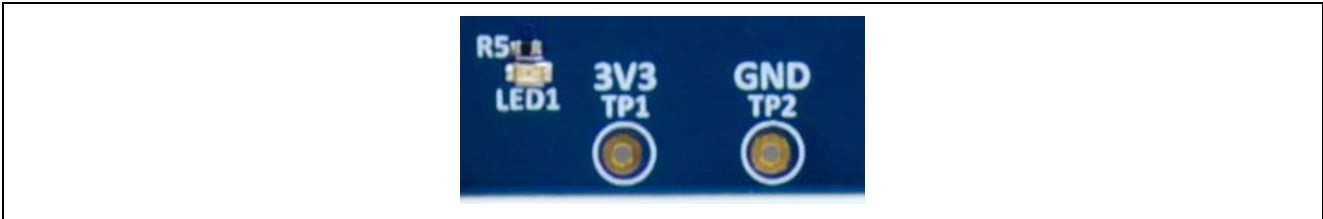

Figure 7. TP1, TP2, and LED1 on the Target Board



These test points supply voltage directly to the S5D5 MCU, the S124 J-Link MCU, and other on-board circuitry. Use caution to ensure that any voltage connected in this manner meets the power requirements for the active features. Power sources that are outside of the published operating range for the active devices may cause degraded performance or damage the board.

### 5.2.1.4 Option 4: Pin Headers

TB-S5D5 can also be powered through the following pin-headers on the board.

- J1 (pin J1-15 for +3.3V, pin J1-17 for Return)
- J2 (pin J2-10 for +3.3V, pin J2-12 for Return)
- J4 (pin J4-37 for +3.3V, pin J4-36 for Return)

Copper jumper E35 must be open for any of these configurations.



The pin headers supply voltage directly to the S5D5 MCU, the S124 J-Link MCU, and other on-board circuitry. Use caution to ensure that any voltage connected in this manner meets the power requirements for the active features. Power sources that are outside of the published operating range for the active devices may cause degraded performance or damage the board.

See section 5.5, Pin Headers for more information on the Pin Headers.

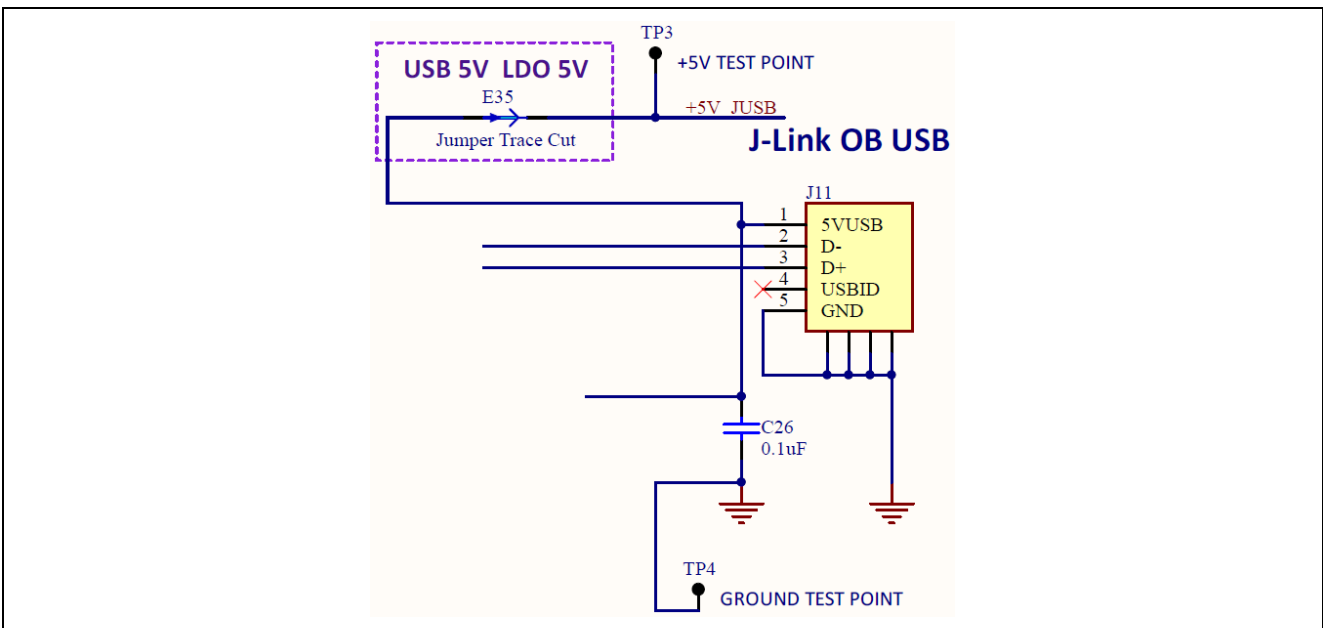

Figure 8. 5 V Power Input Circuit

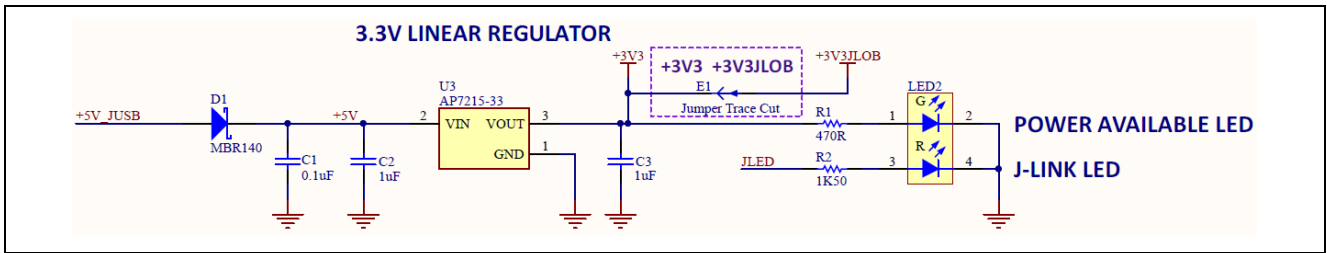

Figure 9. 3.3 V Power Regulator Circuit

### 5.2.2 Powering up the Board

When powered, the green LED to the right of the DEVICE USB connector (LED2) lights up.

The red LED in the same LED package functions as a status indicator for the J-Link® On-Board (OB) debug interface on the board. If both LEDs in the LED2 package are lit, LED2 appears orange.

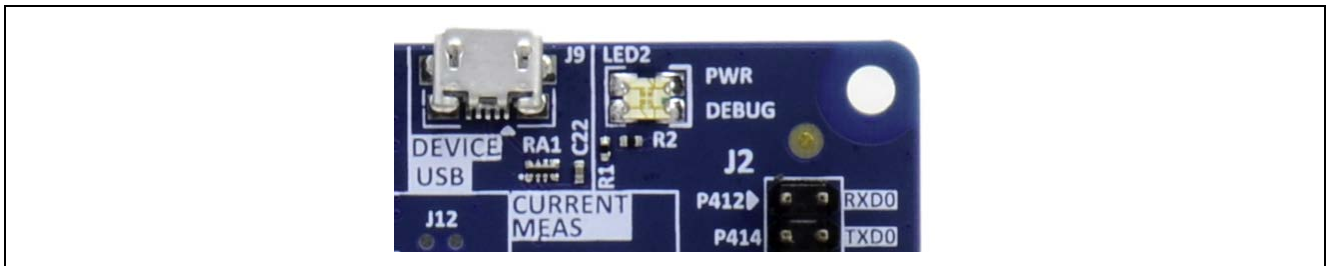

Figure 10. LED2 on the Target Board (Top Side)

### 5.2.3 Battery Supply Configuration

An external battery may be connected according to the methods outlined in section 5.2.1, Power Supply Options, providing that it meets the minimum voltage and current requirements.

Additionally, an external battery source may be connected to VBAT at Pin Header location J2-29 (J2-12 ground return) to maintain the MCU Realtime Clock (RTC) when other main power sources are disconnected from the TB-S5D5 board.

### 5.2.4 Measuring Current Consumption

Pads 1 and 3 of the copper jumper E6, which is a dual trace-cut jumper, allow measurement of +3V3 MCU supply current. Pads 2 and 4 of E6 allow measurement of VBAT supply current. Both traces are connected by default. These traces should be cut to enable power measurement. Care must be taken when cutting the trace to not cause damage to PCB layers below the trace.

The actual current consumed by the S5D5 MCU is dependent on many factors, including ambient temperature, internal clock speed, input voltage level, and device activity. The actual current consumed by the MCU can vary from less than 1 mA to nearly 40 mA. See the *S5D5 Microcontroller Group User's Manual* for more information on the electrical characteristics of the MCU.

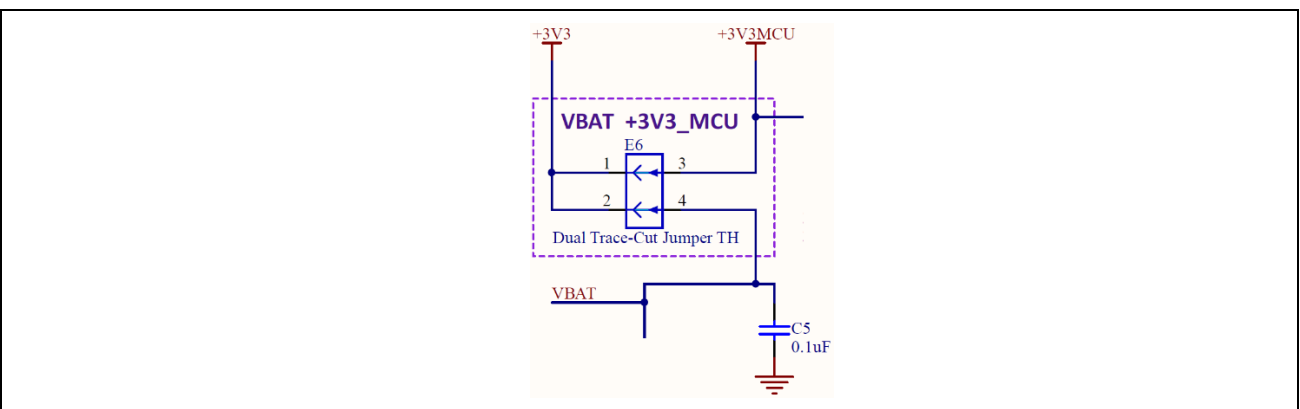

Figure 11. MCU Current Measurement Circuit

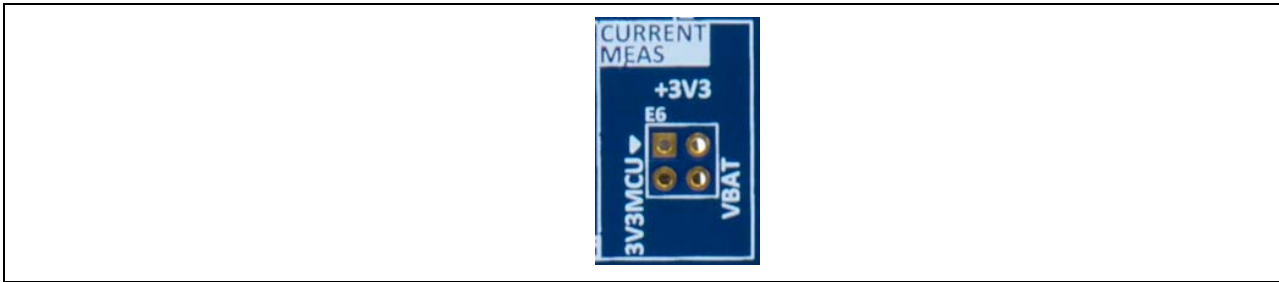

Figure 12. E6 on the Target Board (Top side)



Figure 13. E6 on the Target Board (Bottom side)

Once the shorting traces have been removed, there are several options to measure current:

- Pins can be installed that allow connection of a precision multi-meter or bench meter, or leaded current shunt to allow oscilloscope or data logger connection. When not measuring the current, this allows easily installed and removed shunts to be used to short the jumper terminals.
- Another option is to install current sense resistors between pads 1 and 3 for +3V3 MCU, and between pads 2 and 4 for VBAT. Precision non-inductive film or foil resistors are recommended for use in this application, and the value of each resistor should be carefully considered.

For example, if the expected current requirement for the +3V3 MCU supply voltage is 10 mA, and the user would expect to measure a 10 mV drop across the current measurement resistor, then a 1.0-ohm resistor should be selected and installed.

The actual value selected should be based on the operating conditions of the MCU for the specific user application, and the sensitivity of the measurement equipment used.

### 5.3 Main Components

- Main MCU
  - Renesas Synergy™ S5D5 MCU device, part number R7FS5D5783A01CFP#AA0 (U1)
- J-Link MCU
  - Renesas Synergy™ S124 MCU device, part number R7FS124773A01CFM#AA0 (U2)
- USB Connectors
  - FCI, part number 10118192-0001LF (J9, J11)
    - Micro USB 2.0 Female connector
    - Primary communication with Main MCU and J-Link MCU
- Push-Buttons
  - C&K, part number PTS645SM43SMTR92 LFS (S1, S2)
    - Momentary push-button switch
    - Used for system reset and user defined functions
- LDO Regulator
  - Diodes Inc., part number AP7215-33YG-13 (U3)
    - Low-drop out linear regulator
    - Generates system 3.3 V from J-Link USB 5 V input
- PMOD A Connector
  - Samtec, part number SSW-106-02-F-D-RA (J5)
    - 12-pin right angle connector for PMOD A
- PMOD B Connector
  - Samtec, part number SSW-106-02-FM-S-RA (J6)
    - 6-pin right angle connector for PMOD B
- Pin Headers
  - Sullins, part number PRPC020DAAN-RC (J1, J2, J3, J4)
    - 40 position pin header, 0.1" pitch
    - Provides signal breakout and access for Main MCU signals
- System LED
  - Dialight, part number 598-8610-207F (LED2)
    - Dual color red/green LED
    - System status indicator for power and J-Link status
- User LED
  - Lite-On, part number LTST-C191KRKT (LED1)
    - User defined
    - Single color red LED as needed for user environment
- User Potentiometer
  - Bourns, part number 3352T-1-1-3LF (POT1)
    - User defined
    - Provides variable resistance as needed for user environment
    - Not populated by default

## 5.4 Connectivity and Settings

Throughout this section, feature configuration using copper jumpers is described. See section 4.1.1, Copper Jumpers for information on using copper jumpers.

### 5.4.1 Device USB

The DEVICE USB Micro-B connection jack connects the Main MCU to an external USB Host, FS capable, allowing communications for testing and use of the Main MCU firmware. Power for the Target Board cannot be received from this connector. The DEVICE USB interface can detect the presence of power from the USB Host PC. USB Host power received at the DEVICE USB interface is not connected to the Target Board 5 V power bus.



**Table 2. DEVICE USB Connector (J9)**

USB Device Connector		TB-S5D5
Pin	Description	Signal/Bus
1	+5VDC, connected to a sense voltage 2/3 divider to allow Main MCU sensing of Host presence	+5VUSB P407/USB_VBUS = 2/3(5VUSB)
2	Data-	P915/USB_DM
3	Data+	P914/USB_DP
4	USB ID, jack internal switch, cable inserted	N.C.
5	Ground	GND

USB FS copper jumpers E16, E17, E20, and E21 configure the connection between the Device USB jack and the Main MCU. To allow use of the Device USB jack, copper jumper E16 and E17 must be closed, and copper jumpers E20 and E21 must be open.



USB\_VBUS copper jumper E30 configures P407 as a VBUS power detector. E30 is closed by default to enable Device USB detection. To use P407 for any other purpose, E30 should be open.

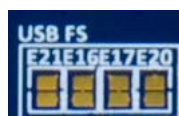

VCC USB copper jumpers E8 and E14 configure the source for the VCC USB power. To provide VCC\_USB from +3V3MCU, E8 must be closed. To isolate VCC\_USB from +3V3MCU, E8 must be open. To source +3V3MCU power from J1, or to monitor VCC\_USB voltage from J1, E14 pads must be closed, otherwise, E14 should be left open.



The VCC\_USB pin on the MCU (pin 40) is used to detect the presence of a USB connection.

**Table 3. USB Source Copper Jumper Settings**

Copper Jumper	USB Signal Source		Function
	Device USB Micro-B Connector	MCU Pin Header	
E16	Closed	Open	USB N signal to MCU
E17	Closed	Open	USB P signal to MCU
E8	Closed	Open	+3V3MCU to MCU VCC_USB
E30	Closed	Open	Connect USB 5V to MCU P407
E20	Open	Closed	USB P signal to MCU
E14	Open	Closed	USB Micro-B 3.3V to MCU VCC_USB
E21	Open	Closed	USB N signal to MCU

P407 is also used by the Capacitive Touch interface.

**Table 4. Device USB Interface Shared Ports**

J-Link Interface		Sharing Interface	
Port	Use	Interface	Use
P407	USB_VBUS	Capacitive Touch	TS3



### 5.4.2 Debug USB

The DEBUG USB Micro-B connection jack connects the S124 J-Link MCU to an external USB Host, FS capable, allowing re-programming and debugging of the Main MCU firmware. Power for the Target Board may be received from this connector.

The J-Link® OB interface is multiplexed with the JTAG interface and can collectively be referred to as the Programming Interface. While the J-Link OB interface and the JTAG interface do not conflict, the J-Link OB signals may be isolated from the programming interface by changing the associated copper jumpers.

J-Link Disconnect Copper Jumpers E32, E33, E34, E37, and E38, connect the J-Link signals to the MCU programming interface. To isolate the J-Link signals from the JTAG interface, the copper jumpers must be open. To allow use of the J-Link interface, each copper jumper must be closed.

J-Link MCU Power Copper Jumper, E1, connects the main +3.3 V power to the J-Link +3.3 V power. The default condition for E1 is closed, which connects the J-Link MCU power to the main +3.3 V power. If J-Link signals are disconnected, the power to the J-Link MCU should also be removed by changing E1 to open.

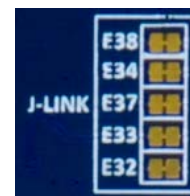

**Table 5. DEBUG USB Connector (J11)**

DEBUG USB Connector		TB-S5D5
Pin	Description	Signal/Bus
1	+5VDC	+5V_JUSB
2	Data-	U2 USB_DM (U2-18)
3	Data+	U2 USB_DP (U2-19)
4	USB ID, jack internal switch, cable inserted	N.C.
5	Ground	GND

Three of the J-Link ports (P108, P109, and P300) conflict with the SPI interface, as shown in the following table.

**Table 6. J-Link Interface Conflicts**

Programming Interface		Conflicting Interface	
Port	Use	Interface	Use
P108	SWDIO/JTAG TMS	SPI	SSLB0 fixed function, J1-13
P109	SWO/JTAG TDO	SPI	MOSIB fixed function, J1-7
P300	SWCLK/JTAG TCK	GPT	GTIOC0A fixed function, J1-31

### 5.4.3 JTAG/SWD

A 10-pin Cortex® Debug Connector is provided at J10.

**Table 7. JTAG Connector (J10)**

JTAG Connector			TB-S5D5
Pin	JTAG pin name	SWD pin name	Signal/Bus
1	VTref	VTref	+3V3
2	TMS	SWDIO	U1 P108/SWDIO (U1-51)
3	GND	GND	GND
4	TCK	SWCLK	U1 P300/SWCLK (U1-50)
5	GND	GND	GND
6	TDO	SWO	U1 P109 (U1-52)
7	Key	Key	N.C.
8	TDI	NC/EXTb	U1 P110 (U1-53)
9	GNDDetect	GNDDetect	N.C. (short E31 to connect to GND)
10	nSRST	nSRST	U1 RESET# (U1-38)

The Cortex® Debug Connector is fully described in the *Arm® CoreSight™ Architecture Specification*.

The J-Link MCU Power Copper Jumper and J-Link Disconnects Copper Jumpers may be open for proper operation of the JTAG interface to prevent interactions with the J-Link MCU. See section 5.4.2, Debug USB for details.

If a JTAG adapter is in use, that properly interprets the Arm® Cortex 10-pin Debug Connector assignment of pin 9 to GND, the JTAG GNDDetect copper jumper E31 should be closed. If the JTAG adapter used is one of several that may be confused or damaged by the presence of GND at pin 9, E31 should be open (as shipped).



The J-Link® OB interface is multiplexed with the JTAG interface, and can collectively be referred to as the Programming Interface. While the J-Link® OB interface and the JTAG interface do not conflict, the J-Link® OB signals may be isolated from the programming interface by changing the copper jumpers as described in section 5.4.2, Debug USB.

Four of the JTAG ports (P108, P109, P110, and P300) conflict with the SPI interface, as shown in the following table.

**Table 8. JTAG Interface Conflicts**

Programming Interface		Conflicting Interface	
Port	Use	Interface	Use
P108	TMS/J-Link SWDIO	SPI	SSLB0_B fixed function, J1-13
P109	TDO/J-Link SWO	SPI	MOSIB_B fixed function, J1-7
P110	TDI	SPI	MISOB_B fixed function, J1-9
P300	SWCLK	GPT	GTIOC0A_A fixed function, J1-31

**5.4.4 LEDs**

Two LEDs are provided on the TB-S5D5. Target Board U1 is the Main MCU, and directly controls LED1. See Figure 7 for LED1 location, Figure 10 for LED2 location, and Figure 9 for LED2 circuit. Target Board U2 is the J-Link MCU, and controls the red LED in LED2.

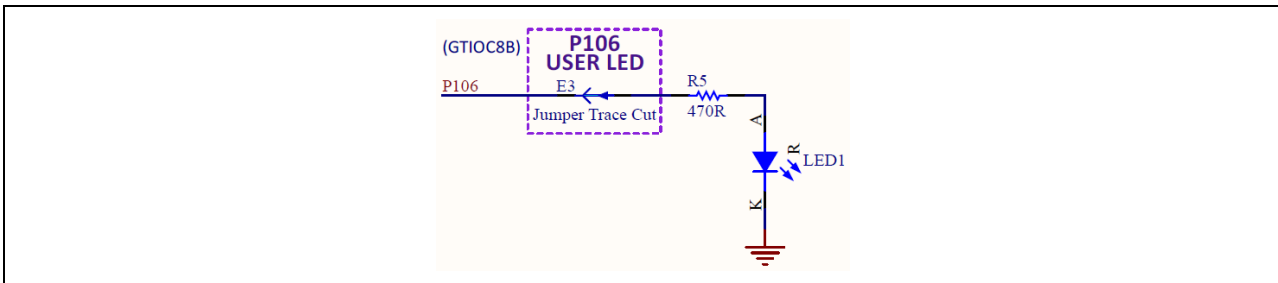

**Figure 14. LED1 Control Circuit**

The behavior of the LEDs is described in the following table.

**Table 9. Target Board LED Functions**

Designator	Color	Function	MCU Control Port	MCU Pin
LED1	Red	User LED	U1 P106	U1-102
LED2	Red	J-Link Indicator	JLED (U2 P103)	U2-45
LED2	Green	3.3 V Power Available	+3V3	N.A.

To disconnect the User LED from the MCU signal P106, the copper jumper E3 must be open.



**5.4.5 Switches**

Two miniature, momentary, mechanical push-button type SMT switches are mounted on the Target Board. Pressing the RESET Switch generates a reset signal to restart the Main MCU.

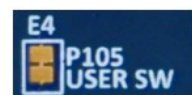

To disconnect the User Switch from the MCU signal P105/IRQ0, copper jumper E4 must be open.

**Table 10. Target Board Switches**

Designator	Function	MCU Control Port	MCU Pin
S1	User Switch	U1 P105/IRQ0	U1-103
S2	MCU Reset Switch	RESET#	U1-55

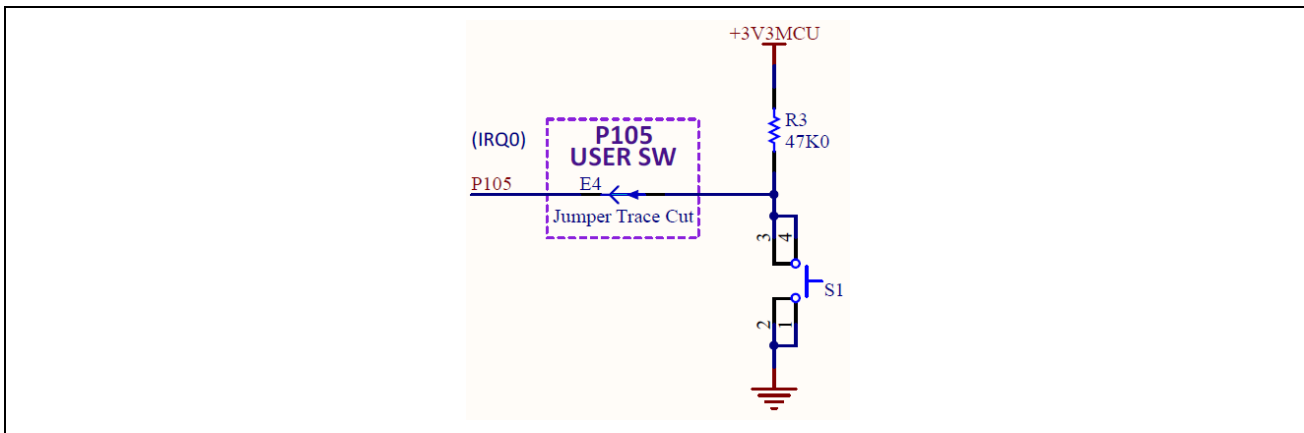

**Figure 15. User Switch Circuit**



**Figure 16. User Switch (S1) on the Target Board**

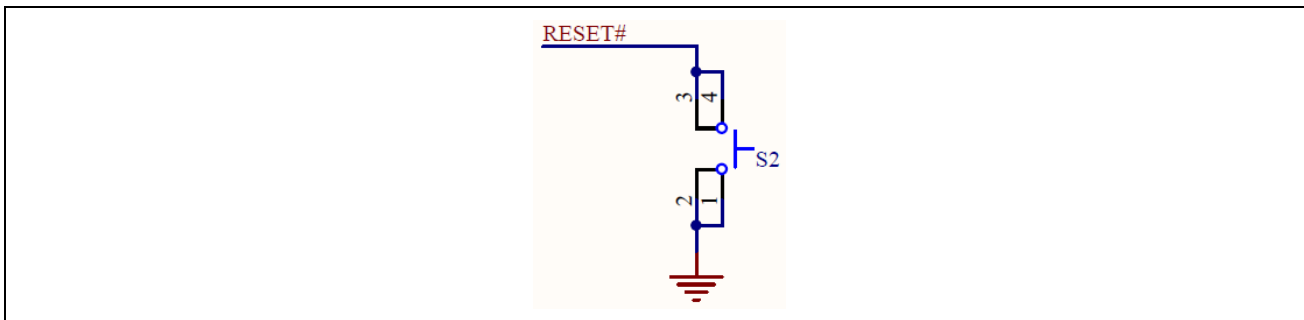

**Figure 17. Reset Switch Circuit**

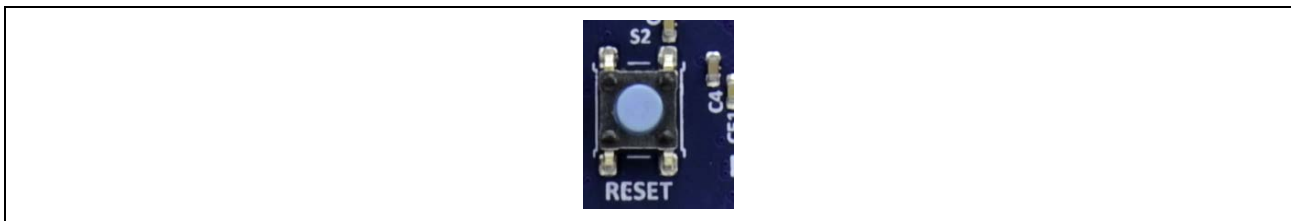

**Figure 18. Reset Switch (S2) on the Target Board**

### 5.4.6 PMOD A

A 12-pin PMOD type 2A connector is provided at PMOD A. The interface is powered for 3.3 V modules only. The Main MCU acts as the SPI master, and the connected module acts as an SPI slave device. This interface may additionally be re-configured in firmware as several other PMOD types.



Signals on PMOD A are shared with Main MCU pin headers J1 and J2. Care must be taken to ensure that shared signals are not used concurrently.

**Table 11. PMOD A Connector (J5)**

USB Device Connector		TB-S5D5
Pin	Description	Signal/Bus
1	SS (low to select slave)	U1 P103, SSLA0_A (U1-105)
2	MOSI	U1 P101, MOSIA_A (U1-107)
3	MISO	U1 P100, MISOA_A (U1-108)
4	SCK	U1 P102, RSPCKA_A (U1-106)
5	GND	GND
6	VCC	+3V3
7	INT (slave to master)	U1 P104, IRQ1 (U1-104)
8	RESET (master to slave)	U1 P107, GPIO (U1-101)
9	Not Specified	U1 P111, GPIO (U1-76)
10	Not Specified	U1 P112, GPIO (U1-77)
11	GND	GND
12	VCC	+3V3

Limits of the 3.3V regulator on the Target Board, and limits of the power source supplying that regulator (especially for USB Host devices), including the to-be-connected PMOD device, must be considered prior to connecting a module to a PMOD connector.

### 5.4.7 PMOD B

A 6-pin PMOD type 4 connector is provided at PMOD B. The interface is powered for 3.3 V modules only. The Main MCU acts as the UART DCE, and the connected module acts as the UART DTE. This interface may additionally be re-configured in firmware as some other PMOD type.



Signals on PMOD B are shared with Main MCU pin header J1 and J2. Care must be taken to ensure that shared signals are not used concurrently.

**Table 12. PMOD B Connector (J6)**

USB Device Connector		TB-S5D5
Pin	Description	Signal/Bus
1	CTS (from module)	U1 P403, CTS1 (U1-4)
2	TXD	U1 P401, TXD1 (U1-2)
3	RXD	U1 P402, RXD1 (U1-3)
4	RTS (from Main MCU)	U1 P400, GPIO (U1-1) (for RTS by Main MCU firmware)
5	GND	GND
6	VCC	+3V3

Limits of the 3.3 V regulator on the Target Board, and limits of the power source supplying that regulator (especially for USB Host devices), including the to-be-connected PMOD device, must be considered prior to connecting a module to a PMOD connector.

**Table 13. PMOD B Interface Conflicts**

PMOD B Interface		Conflicting Interface	
Port	Use	Interface	Use
P402	RXD1	CAN	CRX0_B fixed function, J1-27
P403	CTS1	J-Link	SD1DAT7 SDHI fixed, J4-2

### 5.4.8 User Capacitive Touch Button

A capacitive sensor region for use as a Capacitive Touch button is provided in the board USER INPUT region. A support circuit, TSCAP, is required for proper operation of Capacitive Touch button(s) by the Main MCU.

To disconnect the Capacitive Touch Button from the MCU, the copper jumper E2 must be open.

To connect MCU signal P115 to pin header J3, the copper jumper E5 must be closed.



Note: Capacitor C33 is optional. This design does not include a dielectric overlay, so C33 is added to reduce the sensitivity of the Capacitive Touch Button. This capacitor is not required by the MCU specification.

Table 14. Target Board Capacitive Touch Button Sensor

Designator	Function	MCU Control Port	MCU Pin
TS1	Capacitive Touch Button	U1 P207	U1-41
TSCAP-A	TSCAP Support	U1 P205 (TSCAP-A)	U1-43

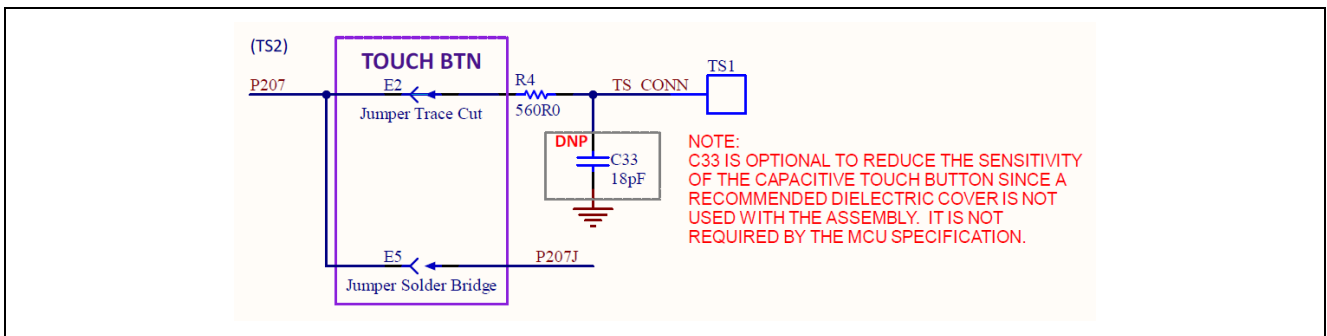

Figure 19. Capacitive Touch Button Circuit

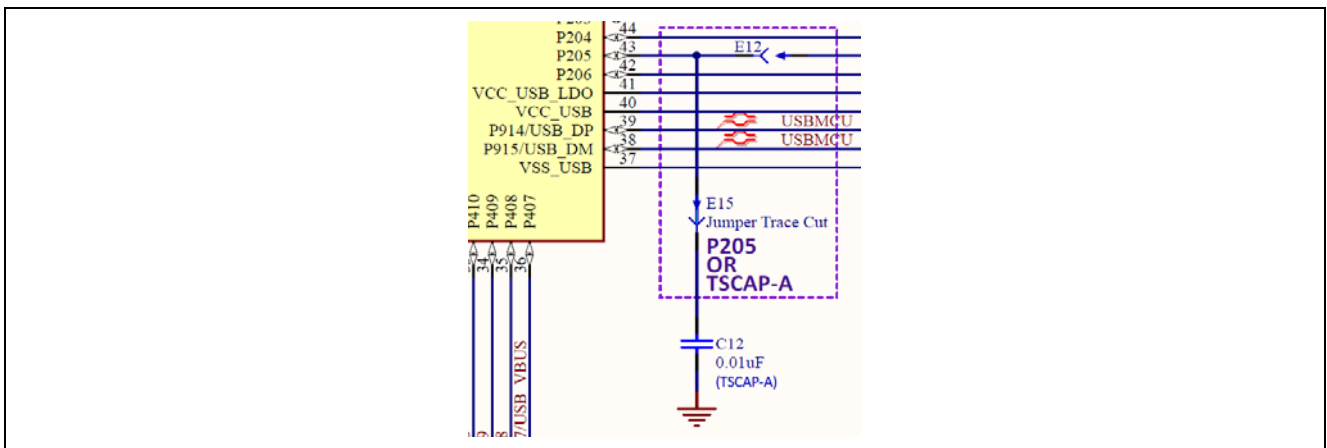

Figure 20. Capacitive Touch TSCAP Circuit



Figure 21. Capacitive Touch Button on the Target Board (Top side)



### 5.5 Pin Headers

The Target Board Pin Headers, J1, J2, J3, and J4, provide access to all Main MCU interface signals, and to voltages for all Main MCU power ports.

#### Fixed Function Pin Assignments

For consistency across all Synergy Target Board Kits, some pin assignments on the headers have **fixed function** signal assignments. This provides specific signals and functions to be at a common pin header location on all Target Boards for S1, S3, S5, S7 Synergy MCU Series.

On the TB-S5D5, 40 pins of the pin headers are set aside for **fixed function** assignment. These pins are odd-numbered pins of J1 and even-numbered pins of J2.

Pin Header Fixed Function pins are labeled on the Target Board with dark text on a white background. Pins that are not Fixed Function pins are labeled with white text on a dark background. On the top side of the board is the functional label for the fixed location. On the bottom side of the board is the port information for the same pin.



Figure 22. Fixed Function Pin Label Example

There are several pins in the headers that are **secondary fixed function** pins. These secondary fixed function pins share common pin assignments with other Target Boards that have Main MCUs with the same functionality. The secondary fixed function pins are also labeled with the top side having a functional label, and bottom side having a port label.

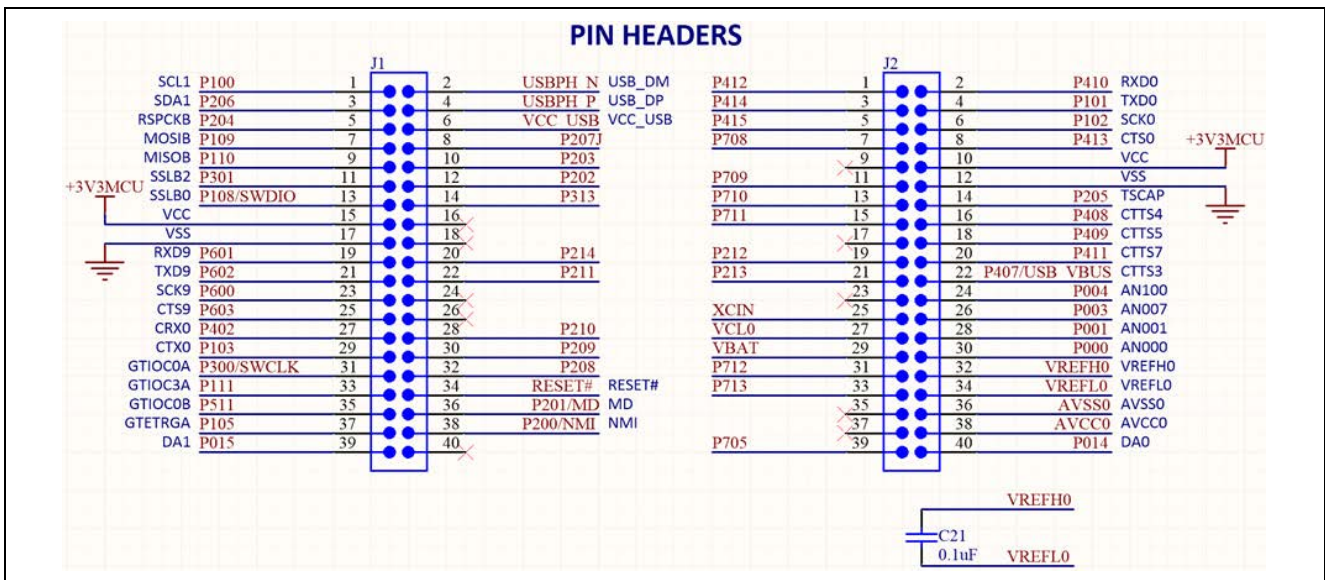

Figure 23. Pin Headers Circuits, J1 and J2

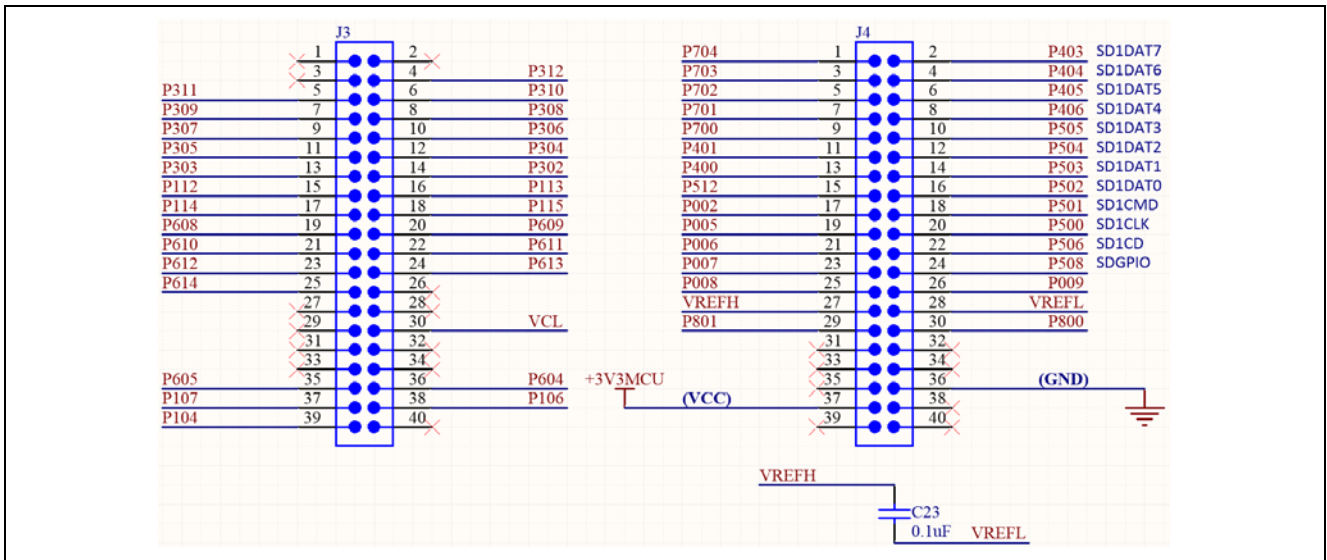

Figure 24. Pin Header Circuits, J3 and J4

### 5.5.1 Pin Header J1

Pin header J1 is a 2-column by 20-row through-hole pin header on 2.54 mm centers.

Table 15. Pin Header J1 Pin Assignment

MCU Pin	Signal	Port	J1 Pins		Signal	MCU Pin
108	SCL	P100	1	2	USB_DM	28
42	SDA	P206	3	4	USB_DP	27
44	RSPICLK	P204	5	6	VCC_USB	29
74	MOSI	P109/TDO	7	8	P207	NC
75	MISO	P110/TDI	9	10	P203	NC
71	SSL	P301	11	12	P202	34
73	SSL	P108/TMS/SWDIO	13	14	P313	35
90	VCC	VCC	15	16	Not Connected	41
91	VSS	VSS	17	18	Not Connected	NC
97	RXD/SCL/MISO	P601	19	20	P214	43
96	TXD/SDA/MOSI	P602	21	22	P211	44
98	SCK	P600	23	24	Not Connected	45
95	CTS_RTS/SS	P603	25	26	Not Connected	46
3	CRX	P402	27	28	P210	47
105	CTX	P103	29	30	P209	NC
72	GTIOC	P300/TCK/SWCLK	31	32	P208	NC
76	GTIOC	P111	33	34	RESET#	38
144	GTIOC	P511	35	36	P201/MD	39
103	GTETRG	P105	37	38	P200	40
123	DA	P015	39	40	Not Connected	55

#### Color Key

Primary Fixed Function Pins
Secondary Fixed Function Pins

### 5.5.2 Pin Header J2

Pin header J2 is a 2-column by 20-row through-hole pin header on 2.54 mm centers.

**Table 16. Pin Header J2 Pin Assignment**

MCU Pin	Signal	J2 Pins		Port	Signal	MCU Pin
31	P412	1	2	P410	RXD/SCL/MISO	33
29	P414	3	4	P101	TXD/SDA/MOSI	107
28	P415	5	6	P102	SCK	106
27	P708	7	8	P413	CTS_RTS/SS	30
NC	Not Connected	9	10	VCC	VCC	21
26	P709	11	12	VSS	VSS	18
25	P710	13	14	P205	TSCAP	43
24	P711	15	16	P408	TS	35
NC	Not Connected	17	18	P409	TS	34
20	P212/EXTAL	19	20	P411	TS	32
19	P213/XTAL	21	22	P407	TS	36
NC	Not Connected	23	24	P004	AN	136
16	XCIN	25	26	P003	AN	137
15	VCL0	27	28	P001	AN	139
14	VBATT	29	30	P000	AN	140
23	P712	31	32	VREFH0	VREFH	130
22	P713	33	34	VREFL0	VREFL	129
NC	Not Connected	35	36	AVSS0	AVSS	128
NC	Not Connected	37	38	AVCC0	AVCC	127
13	P705	39	40	P014	DA	124

Color Key

Primary Fixed Function pins
Secondary Fixed Function pins

### 5.5.3 Pin Header J3

Pin header J3 is a 2-column by 20-row through-hole pin header on 2.54 mm centers.

**Table 17. Pin Header J3 Pin Assignment**

MCU Pin	Signal	Port	J3 Pins		Signal	MCU Pin
NC		Not Connected	1	2	Not Connected	NC
NC		Not Connected	3	4	P312	58
59		P311	5	6	P310	60
61		P309	7	8	P308	62
63		P307	9	10	P306	64
65		P305	11	12	P304	66
69		P303	13	14	P302	70
77		P112	15	16	P113	78
79		P114	17	18	P115	80

MCU Pin	Signal	Port	J3 Pins		Signal	MCU Pin
83		P608	19	20	P609	84
85		P610	21	22	P611	86
87		P612	23	24	P613	88
89		P614	25	26	Not Connected	NC
NC		Not Connected	27	28	Not Connected	NC
NC		Not Connected	29	30	VCL	92
NC		Not Connected	31	32	Not Connected	NC
NC		Not Connected	33	34	Not Connected	NC
93		P605	35	36	P604	94
101		P107	37	38	P106	102
104		P104	39	40	Not Connected	NC

Color Key

Secondary Fixed Function pins

### 5.5.4 Pin Header J4

Pin header J4 is a 2-column by 20-row through-hole pin header on 2.54 mm centers.

**Table 18. Pin Header J4 Pin Assignment**

MCU Pin	Signal	J4 Pins		Port	Signal	Function	MCU Pin
12	P704	1	2	P403	SD	DAT7	4
11	P703	3	4	P404	SD	DAT6	5
10	P702	5	6	P405	SD	DAT5	6
9	P701	7	8	P406	SD	DAT4	7
8	P700	9	10	P505	SD	DAT3	118
2	P401	11	12	P504	SD	DAT2	117
1	P400	13	14	P503	SD	DAT1	116
143	P512	15	16	P502	SD	DAT0	115
138	P002	17	18	P501	SD	CMD	114
135	P005	19	20	P500	SD	CLK	113
134	P006	21	22	P506	SD	CD	119
133	P007	23	24	P508	SD	GPIO (WP) *	120
132	P008	25	26	P009			131
126	VREFH	27	28	VREFL			125
110	P801	29	30	P800			109
NC	Not Connected	31	32	Not Connected			NC
NC	Not Connected	33	34	Not Connected			NC
NC	Not Connected	35	36	VSS			122
121	VCC	37	38	Not Connected			NC
NC	Not Connected	39	40	Not Connected			NC

Color Key

Secondary Fixed Function pins

\*Note: The S5D5 MCU does not support the SDHI WP signal, so J4-24 has been assigned an MCU GPIO signal.

## 5.6 Additional Features

### 5.6.1 Analog Reference Voltages

A footprint for installation of capacitors C21 and C23 is provided on the Target Board. These two capacitors provide noise-bypass capability for ports P010/P011 and for ports P012/P013. See Figure 23 and Figure 24 for the circuit design.

Port pair P010/P011 may be assigned as GPIO, where bypass capacitor C21 would damage signal quality. When P010/P011 are to be assigned as VREFH0/VREFL0, installation of the capacitor C21 can reduce reference voltage noise and improve ADC measurement and DAC output quality. The Target Board was designed for Samsung P/N CL10B104KB8NANC, or similar, noise-bypass capacitors.

Port pair P012/P013 may be assigned as GPIO, where bypass capacitor C23 would damage signal quality. When P012/P013 are to be assigned as VREFH/VREFL, installation of capacitor C23 may reduce reference voltage noise and improve ADC measurement and DAC output quality. The Target Board was designed for Samsung P/N CL10B104KB8NANC, or similar, noise-bypass capacitors.

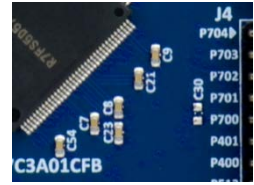

### 5.6.2 On-Board Clock Crystals

The TB-S5D5 includes two precision crystal clock sources. A precision 12.000 MHz crystal is installed at location X1, and a precision 32.768 kHz crystal is installed at location X2. These crystal clock sources are connected to the Main MCU by default.

The MCU pins for the 12 MHz clock crystal may be connected to P212 and P213. To disconnect the 12 MHz crystal, open copper jumpers E23 and E24, and close copper jumpers E18 and E19.

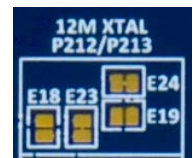

The MCU pins for the 32.768 kHz clock crystal may be connected to P214 and P215. To disconnect the 32.768 kHz crystal, open copper jumpers E25 and E26, and close copper jumpers E22 and E27.

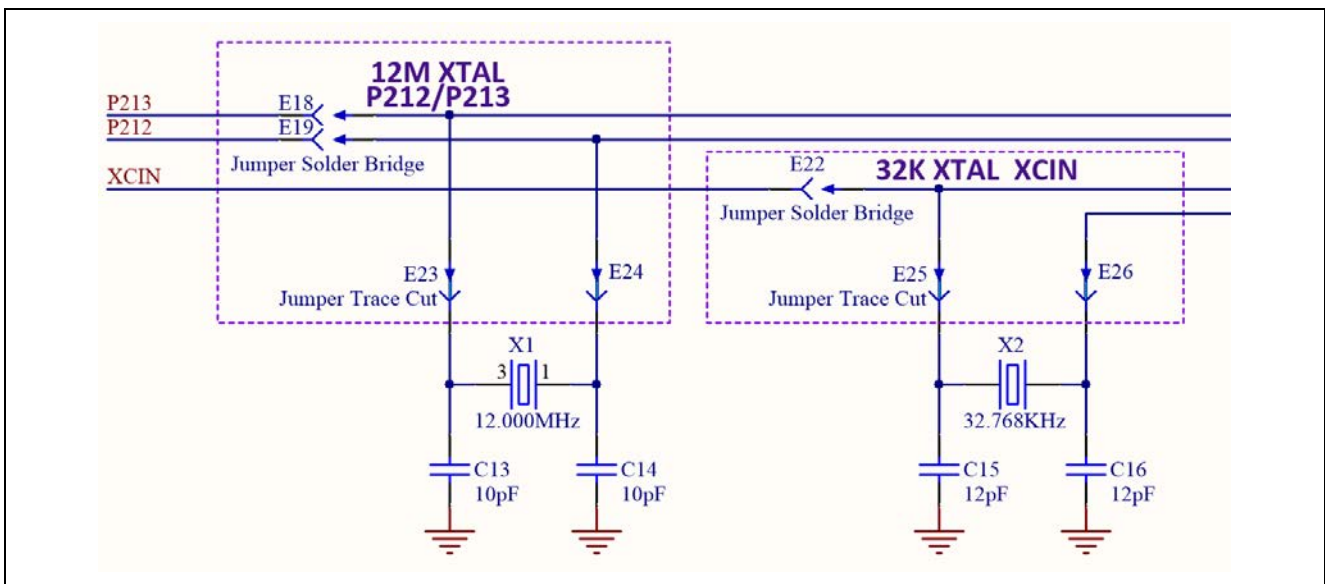

Figure 25. Crystal Clock Sources

### 5.6.3 User Potentiometer

A footprint for installation of a potentiometer and a recommended noise-bypass capacitor are provided on the Target Board for those wishing to demonstrate an analog interface channel on the Target Board. The ADC provides up to 12 bits of resolution for measuring the position of the potentiometer. The Target Board was designed for installation of a Bourns P/N 3352T-1-103LF, or equivalent, as the potentiometer, and a Samsung P/N CL10B104KB8NANC, or similar, as the noise-bypass capacitor.

When the User Potentiometer is installed, copper jumper E36 must be closed to connect the User Potentiometer to the MCU.





**Table 19. Target Board User Potentiometer**

Designator	Function	MCU Control Port	MCU Pin
LED1	User Potentiometer	U1 P004 (AN004)	U1-136

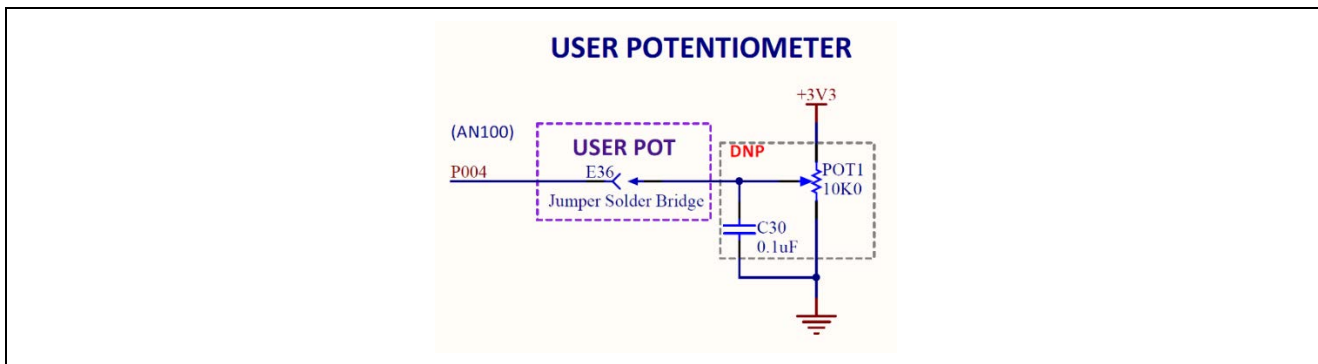

**Figure 26. User Potentiometer Circuit**



**Figure 27. User Potentiometer on the Target Board (top)**

### 5.6.4 Boot Configuration

The BOOT CONFIG jumper, J8 is used to configure the operating mode of the S5D5 MCU at boot.

**Table 20. Boot Configuration**

Boot Configuration	J8 Shunt Location
Normal Boot (default)	Pins 1 and 2
SCI / USB Boot	Pins 1 and 3

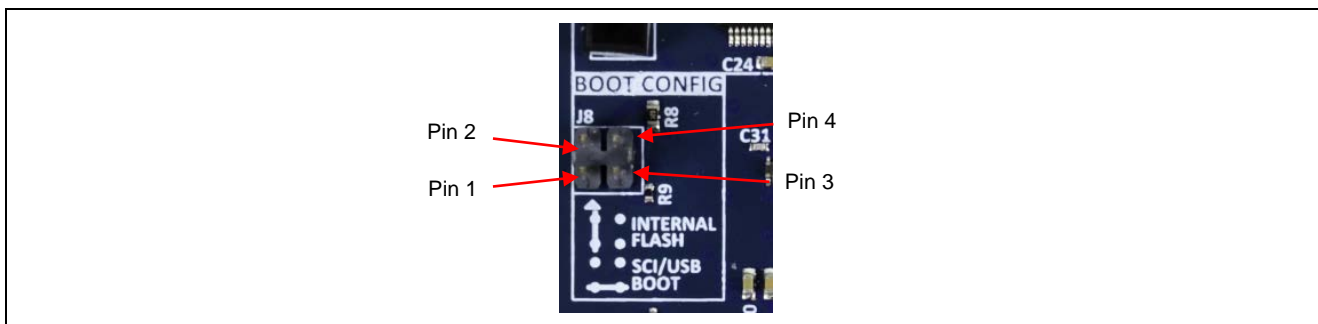

**Figure 28. Boot Configuration Header**

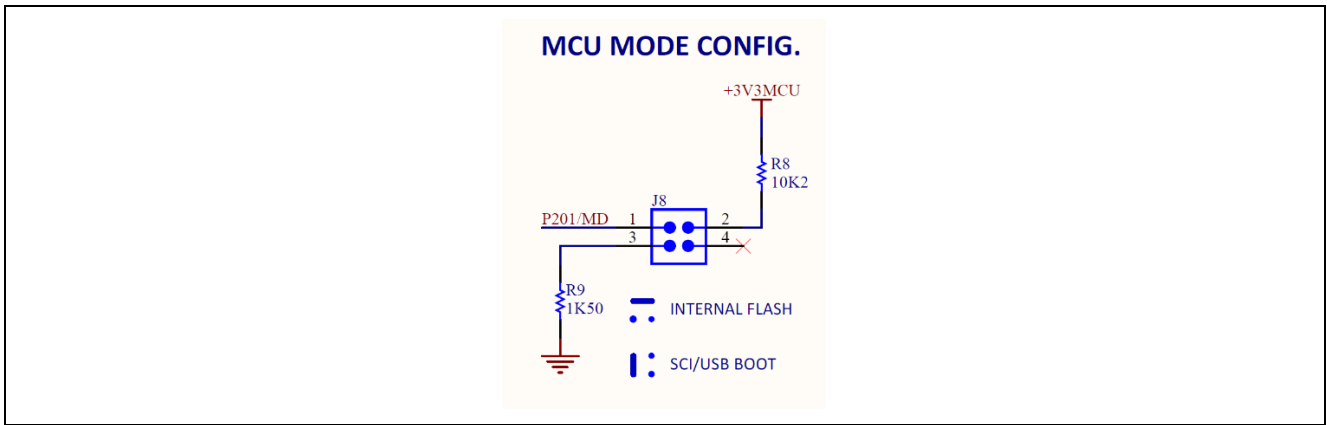

Figure 29. Boot Mode Configuration Circuit

### 5.6.5 Miscellaneous Signals

#### 5.6.5.1 AVCC0/AVSS0

By default, AVCC0 is connected to +3V3 MCU and AVSS0 is connected to the system ground. To disconnect these references from the AVCC0 and AVSS0 lines, copper jumpers E10 and E11 must be open.

By default, VREFH is connected to +3V3MCU, and VREFL is connected to the system ground. To disconnect these references from the VREFH and VREFL lines, copper jumpers E52 and E53 must be open.

By default, VREFH0 is connected to +3V3MCU, and VREFL0 is connected to the system ground. To disconnect these references from the VREFH0 and VREFL0 lines, copper jumpers E50 and E51 must be open.



#### 5.6.5.2 VCL

By default, the Main MCU pin VCL is connected to reference capacitor C51. To connect this pin to MCU pin header J2, copper jumper E55 must be closed. To disconnect the reference capacitor C51, copper jumper E54 must be open.



#### 5.6.5.3 Ext VCL0 and VCL0 Cap

By default, MCU pin VCL0 is connected to reference capacitor C17. To connect this pin to the MCU pin header xx, copper jumper E28 must be closed. To disconnect the reference capacitor C17, copper jumper E29 must be open.



#### 5.6.5.4 VCC\_USB

By default, the Main MCU pin VCC\_USB is connected to the +3V3 MCU supply voltage. Alternatively, this pin may be connected to the MCU pin header J1. To do this, copper jumper E8 must be open and copper jumper E14 must be closed.



#### 5.6.5.5 Signal P205

By default, the Main MCU pin P205 is connected to a TSCAP-A capacitor. This pin may be connected to the MCU pin header J2. To do this, copper jumper E12 must be closed. The TSCAP-A capacitor may be disconnected by making copper jumper E15 open.



## 6. Certifications

The TB-S5D5 v1 meets the following certifications/standards. See page 3 of this user's manual for the disclaimer and precautions.

### 6.1 EMC/EMI Standards

- FCC Notice (Class A)



This device complies with part 15 of the FCC Rules. Operation is subject to the following two conditions: (1) This device may not cause harmful interference, and (2) this device must accept any interference received, including interference that may cause undesired operation.

NOTE- This equipment has been tested and found to comply with the limits for a Class A digital device, pursuant to Part 15 of the FCC Rules. These limits are designed to provide reasonable protection against harmful interference in a residential installation. This equipment generates, uses and can radiate radio frequency energy and, if not installed and used in accordance with the instructions, may cause harmful interference to radio communications. However, there is no guarantee that interference will not occur in a particular installation. If this equipment does cause harmful interference to radio or television reception, which can be determined by turning the equipment off and on, the user is encouraged to try to correct the interference by one or more of the following measures:

- Reorient or relocate the receiving antenna.
- Increase the separation between the equipment and receiver.
- Connect the equipment into an outlet on a circuit different from that to which the receiver is connected.
- Consult the dealer or an experienced radio/television technician for help.

- CE Class A (EMC)



This product is herewith confirmed to comply with the requirements set out in the Council Directives on the Approximation of the laws of the Member States relating to electromagnetic Compatibility Directive 2004/108/EEC.

**Warning** – This is a Class A product. In a domestic environment this product may cause radio interference in which case the user may be required to take adequate measures to correct this interference.

### 6.2 Material Selection, Waste, Recycling and Disposal Standards

- EU RoHS
- China SJ/T 113642014, 10-year environmental protection use period.

### 6.3 Safety Standards

- UL 94V-0

## 7. Design and Manufacturing Information

The design and manufacturing information about TB-S5D5 v1 board are available in the “TB-S5D5 v1 Design Package” available on [renesas.com/synergy/tb-s5d5](https://renesas.com/synergy/tb-s5d5) under the Downloads tab.

- Design package file name: tb-s5d5-v1.2-designpackage.zip
- Design package contents

File Type	Content	File/Folder Name
File (PDF)	Schematics	tb-s5d5-v1.2-schematics
File (PDF)	Mechanical Drawing	tb-s5d5-v1.2-mechdwg
File (PDF)	3D Drawing	tb-s5d5-v1.2-3d
File (PDF)	BOM	tb-s5d5-v1.2-bom
Folder	Manufacturing Files	Manufacturing Files
Folder	Design Files	Design Files - Altium

## Website and Support

Visit the following vanity URLs to learn about key elements of the Synergy Platform, download components and related documentation, and get support.

TB-S5D5 Resources	<a href="https://renesas.com/synergy/tb-s5d5">renesas.com/synergy/tb-s5d5</a>
Synergy Software	<a href="https://renesas.com/synergy/software">renesas.com/synergy/software</a>
Synergy Software Package	<a href="https://renesas.com/synergy/ssp">renesas.com/synergy/ssp</a>
Software add-ons	<a href="https://renesas.com/synergy/addons">renesas.com/synergy/addons</a>
Software glossary	<a href="https://renesas.com/synergy/softwareglossary">renesas.com/synergy/softwareglossary</a>
Development tools	<a href="https://renesas.com/synergy/tools">renesas.com/synergy/tools</a>
Synergy Hardware	<a href="https://renesas.com/synergy/hardware">renesas.com/synergy/hardware</a>
Microcontrollers	<a href="https://renesas.com/synergy/mcus">renesas.com/synergy/mcus</a>
MCU glossary	<a href="https://renesas.com/synergy/mcuglossary">renesas.com/synergy/mcuglossary</a>
Parametric search	<a href="https://renesas.com/synergy/parametric">renesas.com/synergy/parametric</a>
Kits	<a href="https://renesas.com/synergy/kits">renesas.com/synergy/kits</a>
Synergy Solutions Gallery	<a href="https://renesas.com/synergy/solutionsgallery">renesas.com/synergy/solutionsgallery</a>
Partner projects	<a href="https://renesas.com/synergy/partnerprojects">renesas.com/synergy/partnerprojects</a>
Application projects	<a href="https://renesas.com/synergy/applicationprojects">renesas.com/synergy/applicationprojects</a>
Self-service support resources:	
Documentation	<a href="https://renesas.com/synergy/docs">renesas.com/synergy/docs</a>
Knowledgebase	<a href="https://renesas.com/synergy/knowledgebase">renesas.com/synergy/knowledgebase</a>
Forums	<a href="https://renesas.com/synergy/forum">renesas.com/synergy/forum</a>
Training	<a href="https://renesas.com/synergy/training">renesas.com/synergy/training</a>
Videos	<a href="https://renesas.com/synergy/videos">renesas.com/synergy/videos</a>
Chat and web ticket	<a href="https://renesas.com/synergy/resourcelibrary">renesas.com/synergy/resourcelibrary</a>

**Revision History**

Rev.	Date	Description	
		Page	Summary
1.00	Aug.24.17	-	Initial release
1.01	Dec.18.17	-	Replaced the graphics
1.02	Jul.10.19	-	Corrected typo for package type
1.03	Apr.21.20	-	Updated sections 5.4.8, 6, and 7.
1.04	Jun.25.20	23	Corrected Pin Header J2 Pin Assignment table

---

Target Board Kit S5D5 (TB-S5D5) User's Manual

Publication Date: Jun.25.20

Published by: Renesas Electronics Corporation

---



Renesas Synergy™ Platform  
Target Board Kit S5D5 (TB-S5D5)



## X-ON Electronics

Largest Supplier of Electrical and Electronic Components

*Click to view similar products for [Development Boards & Kits - ARM category](#):*

*Click to view products by [Renesas manufacturer](#):*

Other Similar products are found below :

[SAFETI-HSK-RM48](#) [PICOHOBBITFL](#) [CC-ACC-MMK-2443](#) [TWR-MC-FRDMKE02Z](#) [EVALSPEAR320CPU](#) [EVB-SCMIMX6SX](#)  
[MAX32600-KIT#](#) [TMDX570LS04HDK](#) [TXSD-SV70](#) [OM13080UL](#) [EVAL-ADUC7120QSPZ](#) [OM13082UL](#) [TXSD-SV71](#)  
[YGRPEACHNORMAL](#) [OM13076UL](#) [PICODWARFFL](#) [YR8A77450HA02BG](#) [3580](#) [32F3348DISCOVERY](#) [ATTINY1607](#) [CURIOSITY](#)  
[NANO](#) [PIC16F15376](#) [CURIOSITY NANO BOARD](#) [PIC18F47Q10](#) [CURIOSITY NANO](#) [VISIONSTK-6ULL V.2.0](#) [80-001428](#) [DEV-17717](#)  
[EAK00360](#) [YR0K77210B000BE](#) [RTK7EKA2L1S00001BE](#) [MAX32651-EVKIT#](#) [SLN-VIZN-IOT](#) [USB-202](#) [MULTIFUNCTION DAQ](#)  
[DEVICE](#) [USB-205](#) [MULTIFUNCTION DAQ DEVICE](#) [ALLTHINGSTALK](#) [LTE-M RAPID DEV. KIT](#) [ESP32-POE-ISO-EA-IND](#) [ESP32-](#)  
[POE-ISO-IND](#) [ESP32-S2-DEVKIT-LIPO](#) [LV18F V6](#) [DEVELOPMENT SYSTEM](#) [READY FOR AVR BOARD](#) [READY FOR PIC BOARD](#)  
[READY FOR PIC \(DIP28\)](#) [EVB-VF522R3](#) [AVRPLC16](#) [V6 PLC SYSTEM](#) [MIKROLAB FOR AVR XL](#) [MIKROLAB FOR PIC L](#) [MINI-AT](#)  
[BOARD - 5V](#) [MINI-M4 FOR STELLARIS](#) [MOD-09.Z](#) [BUGGY + CLICKER 2 FOR PIC32MX + BLUETOOT](#) [1410](#) [LETS MAKE](#)  
[PROJECT PROGRAM. RELAY PIC](#)