

Description

The [ZMOD4410](#) Gas Sensor Module is designed for detecting total volatile organic compounds (TVOC), estimating CO₂, and monitoring indoor air quality (IAQ) in different smell based use cases, including very humid and dusty applications with the possibility of water spray, condensation, or immersion. It is a 12-LGA assembly (3.0 × 3.0 × 0.7 mm) that consists of a gas sense element and a CMOS signal conditioning IC. The module's sense element consists of heater element on a Si-based MEMS structure and a metal oxide (MOx) chemiresistor. The signal conditioner controls the sensor temperatures and measures the MOx conductivity, which is a function of the gas concentration. The measurement results can be read via an I²C interface with the user's microprocessor, which processes the data.

The provided firmware enables different ZMOD4410 features based on traditional and machine learning algorithms with an embedded artificial intelligence (AI). This is used to determine the TVOC concentration, IAQ rating, and estimated carbon dioxide (eCO₂) level. Alternatively, depending on the operation mode, the ZMOD4410 algorithm can discriminate between sulfur-based odors or generate a control signal, which can trigger actions based on total odor levels. With its low operating current consumption in Low Power Operation Mode, the ZMOD4410 is an excellent choice for low-voltage and low power battery applications. Built-in nonvolatile memory (NVM) stores the module configuration and calibration data.

Typical Applications

- Indoor air monitoring
- Monitor home, office, personal, and bathroom environments for healthy conditions and comfort
- Detect hazardous materials and unhealthy conditions (e.g., fumes from construction materials)
- Automation based on indoor ambient air quality (HVAC, air purifiers, thermostats, kitchen hoods, etc.)

Available Support

- ZMOD4410 Evaluation Kit
- Manuals, application notes, blog, and white papers
- Instructional videos
- Programming libraries, example codes, and algorithm support to optimize performance
- Third-party certification for compliance with well-accepted international IAQ standards and best available technology for eCO₂

Features

- Sensor output based on AI machine learning algorithmic:
 - Measurement of total organic compounds (TVOC) concentrations and indoor air quality (IAQ)
 - Module algorithm estimates carbon dioxide level (eCO₂)
 - Algorithm to set a control signal to trigger an external action based on IAQ and odor change
 - Algorithm to discriminate sulfur-based odors
- Heater driver and regulation loop for constant resistance, minimizing effect of environmental temperature on signal
- Customization for mobile, industrial, and consumer applications
- I²C interface: up to 400kHz
- Built-in nonvolatile memory (NVM) for module-specific data
- Very low average power consumption down to 1.5mW
- Excellent for low-voltage and low power battery applications
- No external trimming components required
- External reset pin (active-LOW)
- Siloxane resistant
- RoHS compliant
- Supply voltage: 1.7V to 3.6V
- Package: 12-LGA
- Water and dustproof version available (IP67 certified)
- Available assembly sizes:
 - 3.0 × 3.0 × 0.7 mm (standard version)
 - 3.0 × 3.0 × 0.9 mm (for IP67 version)

ZMOD4410 Application Circuit

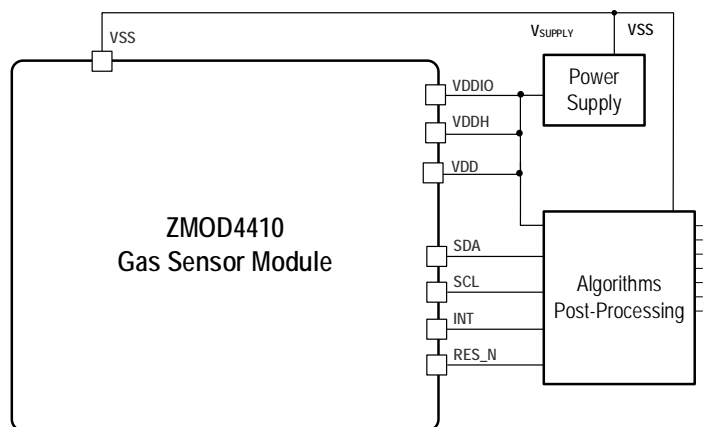

Contents

1. Pin Assignments.....	4
2. Pin Descriptions.....	4
3. Absolute Maximum Ratings.....	5
4. Operating Conditions.....	5
5. Electrical Characteristics.....	6
6. Block Diagram.....	7
7. Sensor Module Characteristics.....	8
7.1 Gas Sensor Module.....	8
8. Gas Sensor Module Operation Modes and Characteristics.....	9
8.1 Operation Modes 1–3.....	9
8.1.1 Air Quality – UBA Levels.....	9
8.1.2 Air Quality – Estimated Carbon Dioxide Correlation (eCO ₂).....	11
8.2 Operation Mode 4: Odor (Relative Measurement).....	11
8.3 Operation Mode 5: Sulfur based Odor Discrimination.....	12
8.4 Conditioning and Stability.....	12
8.5 Environmental Temperature and Humidity.....	13
8.6 Accuracy and Consistency.....	14
8.7 Sensor Module Algorithm and Firmware.....	14
9. Assembly Restrictions, Operation, Integration Notes, and Storage.....	15
10. Test and Calibration.....	16
11. I2C Interface and Data Transmission Protocol.....	16
12. Related Websites and Software.....	18
13. Glossary.....	18
14. Package Outline Drawings.....	19
15. Marking Diagram.....	19
16. Ordering Information.....	19
17. Revision History.....	20

List of Figures

Figure 1. Pin Assignments for 12-LGA Module – Top View.....	4
Figure 2. Block Diagram.....	7
Figure 3. Typical ZMOD4410 Response to Levels of TVOC Described by UBA using EPA Std. Mixture.....	10
Figure 4. Typical Graph of CO ₂ Correlation.....	11
Figure 5. ZMOD4410 Typical Response Time and Signal Stability for TVOC Exposure.....	12
Figure 6. Sensor Module Response to Exposures at Different TVOC Concentrations for 2 Hours Each.....	13
Figure 7. Humidity Influence at Three Different VOC Concentrations.....	13
Figure 8. Accuracy and Consistency for Eight Sensor Modules.....	14
Figure 9. Typical Solder Profile.....	15

Figure 10. I2C Data Transmission Protocol.....17
 Figure 11. Bus Timing.....17

List of Tables

Table 1. Pin Descriptions.....4
 Table 2. Absolute Maximum Ratings.....5
 Table 3. Operating Conditions.....5
 Table 4. Electrical Characteristics6
 Table 5. Gas Sensor Module Specifications during Operation8
 Table 6. Level of Air Quality Based on TVOC Levels Described by UBA.....10
 Table 7. Measurement of Estimated CO₂ Levels (eCO₂)11
 Table 8. Control Parameters for Odor Operation11
 Table 9. Typical ZMOD4410 Sensor Module Accuracy Achievable with Calibration.....14
 Table 10. Final Test Parameters16
 Table 11. Bus Timing Characteristic.....17
 Table 12. Package Options19

1. Pin Assignments

Figure 1. Pin Assignments for 12-LGA Module – Top View

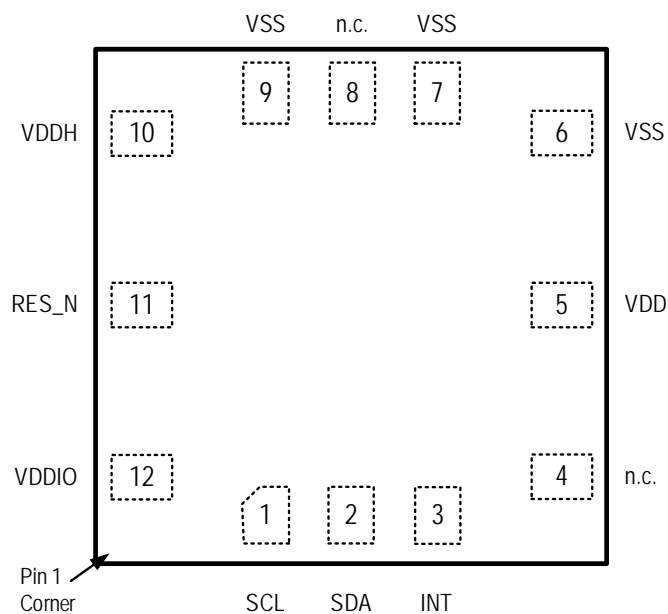

2. Pin Descriptions

Table 1. Pin Descriptions

Pin Number	Name	Type	Description
1	SCL	Input	Serial clock for the I2C interface.
2	SDA	Input/Output	Serial data for the I2C interface. Default 7-bit slave address: 32 _{HEX} .
3	INT	Output	Interrupt signal (push-pull): <ul style="list-style-type: none"> ▪ HIGH when a measurement is running ▪ LOW when a measurement has finished Note, use edge detection on falling edge!
4	n.c.	–	Do not connect.
5	VDD	Supply	Voltage supply for the ZMOD4410.
6	VSS	Ground	Ground reference for the ZMOD4410.
7	VSS	Ground	Ground reference for the ZMOD4410.
8	n.c.	–	Do not connect.
9	VSS	Ground	Ground reference for the ZMOD4410.
10	VDDH	Supply	Voltage supply for the integrated heater in the ZMOD4410.
11	RES_N	Input	ZMOD4410 reset; active low.
12	VDDIO	Supply	Voltage supply for I/O-interface in ZMOD4410.

3. Absolute Maximum Ratings

Note: The absolute maximum ratings are stress ratings only. The ZMOD4410 may not be operable above or below the recommended operating conditions in Table 2. Stresses exceeding the absolute maximum ratings will change the sensor module accuracy, lead to imprecision, and eventually cause irreversible damage to the device. In addition, extended exposure to stresses above the recommended operating conditions may affect device reliability. Renesas does not recommend designing to the "Absolute Maximum Ratings."

Table 2. Absolute Maximum Ratings

Symbol	Parameter	Minimum	Maximum	Unit
$V_{DD}, V_{DDH}, V_{DDIO}$	Maximum Analog and I/O Supply Voltage	-0.4	3.63	V
V_{A_IO}, V_{D_IO}	Maximum Voltage at all Analog and Digital I/O Pins	-0.5	$V_{DDIO} + 0.5$	V
	Maximum Difference in Voltage between VDD and VDDH Pins	-	0.4	V
I_{IN}	Input Current into any Pin Except Supply Pins (Latch-Up Immunity)	-100	100	mA
V_{HBM1}	Electrostatic Discharge Tolerance – Human Body Model (HBM)	-	2000	V
V_{CDM}	Electrostatic Discharge Tolerance – Charged Device Model (CDM) on Packaged Module	-	750	V
$T_{AMB-MAX}$	Maximum Ambient Temperature Range of Sensor Module	-40	125	°C
T_{STOR}	Storage Temperature	-50	125	°C

4. Operating Conditions

Note: The reference for all voltages is V_{SS} .

Table 3. Operating Conditions

Symbol	Parameter	Minimum	Typical	Maximum	Unit
V_{DD}	Supply Voltage	1.7	-	3.6	V
T_{AMB}	Ambient Temperature Range for Sensor Module Operation	-40	-	65	°C
$T_{OPERATION}$	Operation Temperature Sequence of Sense Element [a]	100	-	450	°C

[a] Controlled via API in firmware and EVK software.

5. Electrical Characteristics

Values below are valid at operating conditions unless noted otherwise.

Table 4. Electrical Characteristics

Symbol	Parameter	Conditions	Minimum	Typical	Maximum	Unit
	Average Power: IAQ 1 st Gen	Continuous and Odor Operation Mode	-	23	-	mW
		Low Power Operation Mode	-	1.5	-	mW
	Average Power: IAQ 2 nd Gen		-	6	-	mW
	Average Power: Odor Operation		-	23	-	mW
	Average Power: Sulfur Odor Discrimination		-	6	-	mW
I _{ACTIVE}	Supply Current, Active Mode including Heater Current for IAQ 1 st Gen Continuous and Odor Operation Mode	At VDD = 1.8 V	-	13	-	mA
		At VDD = 3.3V	-	7	-	mA
I _{ACTIVE}	Supply Current, Active Mode including Heater Current for IAQ 2 nd Gen and Sulfur Odor Discrimination	At VDD = 1.8 V	-	3.4	16.2	mA
		At VDD = 3.3V	-	2.4	10.3	mA
I _{SLEEP}	Current during measurement delays	Sleep Mode ASIC	-	450	-	nA
PSRR	Power Supply Rejection Ratio	V _{DD} ≥ 2.0V	-	30	-	dB
	Timing Accuracy (Valid for Measurements Only) (Sleep Timer is ±20%)	At room temperature; for timings derived from the internal clock.	-2	-	2	%
		Over-temperature range; for timings derived from the internal clock.	-0.1	-	0.1	%/K
r _{ADC}	ADC Resolution		10	-	16	Bit
t _{STA1}	Start-up Time: V _{DD} Ramp up to Interface Communication		-	-	1	ms
f _{C,I2C}	I2C Clock Frequency		-	-	400	kHz
t _{VPP}	NVM Programming Time		-	6	16	ms
t _{RET_FTP}	Data Retention	85°C junction temperature	10	-	-	years
	NVM Programming Cycles		1000	-	-	cycles
	Default Communication Address	7-bit slave address	-	32 _{HEX}	-	-
	Blocking Capacitor for Power Supply	Ceramic type; recommended to be placed close to gas sensor module	100	-	-	nF

6. Block Diagram

Note: See section 12 for definitions of abbreviations.

Figure 2. Block Diagram

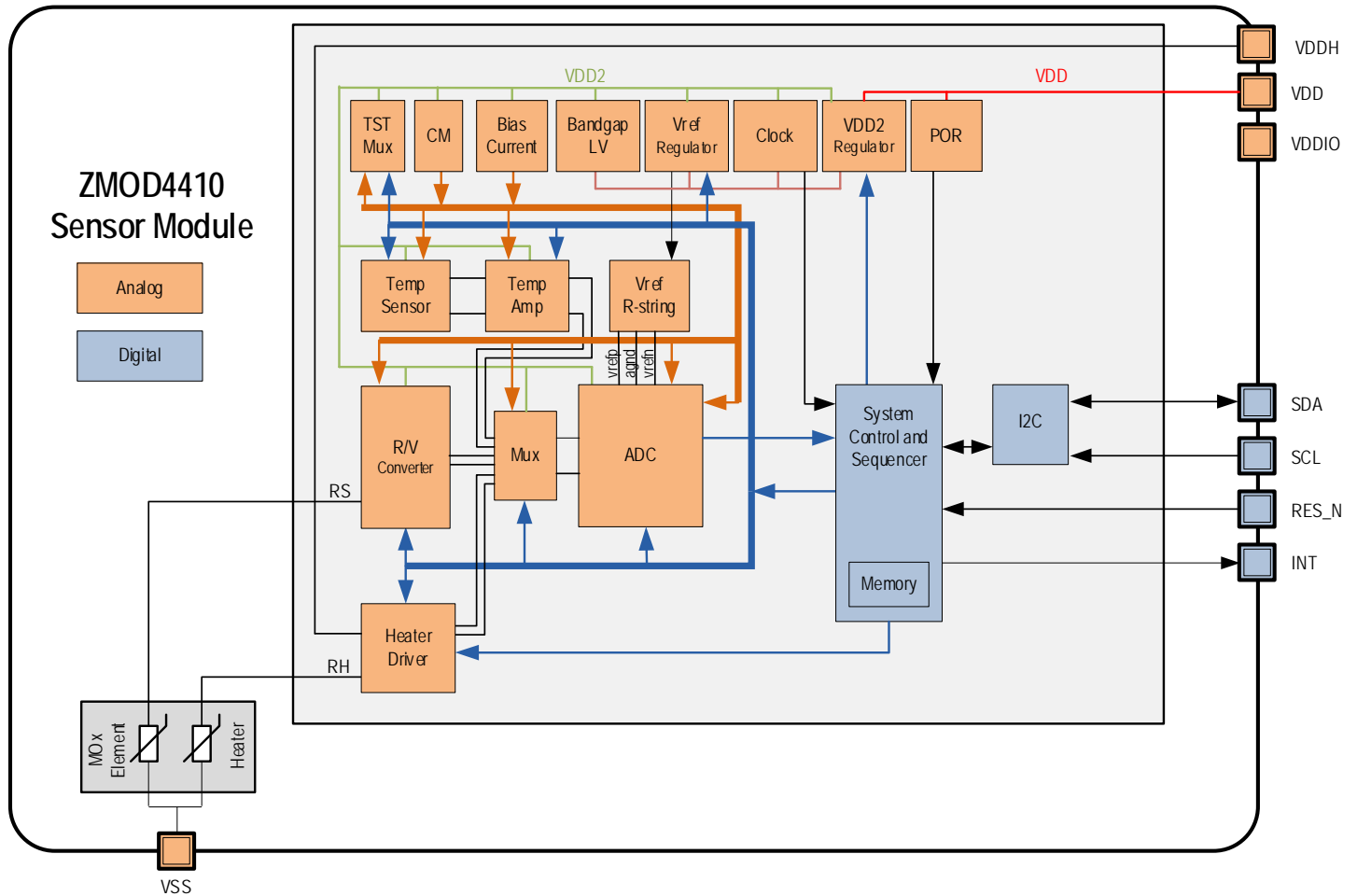

7. Sensor Module Characteristics

7.1 Gas Sensor Module

The ZMOD4410 Gas Sensor Module is designed to detect typical TVOC contaminations based on studies and international standards for indoor air quality. Characteristic module parameters are shown in Table 5. The response time for a gas stimulation is always within a few seconds, depending on the TVOC and its concentration. An active or direct airflow onto the sensor module is not necessary because diffusion of ambient gas does not limit the sensor module's response time.

Important: The ZMOD4410 also can detect safety-relevant gases for indoor air, such as carbon monoxide (CO); however, the sensor module is not designed to detect these interferants reliably and therefore it is not approved for use in any safety-critical or life-protecting applications. It must not be used in such applications, and Renesas disclaims all liability for any such use.

Table 5. Gas Sensor Module Specifications during Operation

Symbol	Parameter	Conditions	Minimum	Typical	Maximum	Unit [a]
	Resistance Measurement Range	Ethanol in air	0		1000	ppm
			0		1000000	ppb [c]
	IAQ Specified Measurement Range [b]	Ethanol in air for IAQ 1 st Gen	160		30000	ppb
		Ethanol in air for IAQ 2 nd Gen	160		10000	ppb
	Humidity Range	Non-condensing	0		90	% RH
S	Sensitivity over Lifetime	Resistance in Air / Resistance at 10ppm Ethanol (R_{Air}/R_{Gas})		5		Ω/Ω
T-80	Sensor Module Response Time [d]	Time to change to 80% of end value		10		s

[a] The abbreviation ppm stands for "parts per million," and ppb is an abbreviation for "parts per billion." For example, 1 ppm equals 1000 ppb.

[b] Source: Umweltbundesamt, *Beurteilung von Innenraumluftkontaminationen mittels Referenz- und Richtwerten*, (Bundesgesundheitsblatt - Gesundheitsforschung - Gesundheitsschutz, 2007).

[c] Conversion from ppm to mg/m³ for most common TVOC is by the factor approximately 2; for example, 5ppm equals approximately 10mg/m³.

[d] Response times depend on TVOC gas and concentration.

8. Gas Sensor Module Operation Modes and Characteristics

The ZMOD architecture leverages different “Methods of Operation” which use time, temperature, and signatures from gases that enable unique signals from a highly trained machine learning system and makes use of embedded artificial intelligence (AI) technology. This section discusses the different operation modes of the ZMOD4410. At present, five operation modes are released.

Family of IAQ software releases:

- Operation Mode 1: IAQ 1st Generation: Continuous – Measurement of UBA levels for IAQ and eCO₂
- Operation Mode 2: IAQ 1st Generation: Low Power – Measurement of UBA levels for IAQ and eCO₂
- Operation Mode 3: IAQ 2nd Generation: Using AI for improved ppm TVOC, IAQ and eCO₂ functionality (recommended for new designs)
- Operation Mode 4: Odor: Relative Measurements – Control signal based on Air Quality Changes
- Operation Mode 5: Sulfur-based Odor Discrimination

By default, the IAQ 2nd Generation (Mode 3) operation should be used for new designs. In case of the need for a slightly faster sample rate and a larger VOC range (up to 30ppm), it is recommended to use the IAQ 1Gen algorithms.

In addition, details for sensitivity, reliability, sample rates, and sensor module influences are explained in detail in the following sections. All graphs and information show the typical responses that are to be expected from the sensor module upon exposure to a variety of test conditions. Additional technical information on sensitivity, selectivity, and stability for all operation modes is available in Renesas' *ZMOD4410 Application Note – TVOC Sensing*. For more information, including application notes, white papers, blog, and manuals, visit the [ZMOD4410](#) webpage.

8.1 Operation Modes 1–3

These operation modes are used for absolute measurements of indoor air quality (IAQ) according to UBA with eCO₂.

Note: Modes 1, 2, and 3 use the same output signal but have differences in power consumption and sample rate. In addition, the use of the IAQ 2nd Generation algorithm with embedded AI gives better consistency and accuracy compared to traditional gas sensor module algorithms.

- Operation Mode 1: IAQ 1st Generation (Continuous) provides continuous data depending on the customer application and MCU polling.
- Operation Mode 2: IAQ 1st Generation (Low Power) has a fixed sampling interval of 6 seconds.
- Operation Mode 3: IAQ 2nd Generation has a fixed sampling interval of 3 seconds.

The following sections provide information on TVOC gases, concentrations, and thresholds given by the German Federal Environmental Agency (UBA)* and the US Environmental Protection Agency (EPA). These standards provide reliable information on indoor air quality and recommendations for air improvements if necessary.

8.1.1 Air Quality – UBA Levels

The algorithm provided by Renesas for the user's microprocessor uses the output from the ZMOD4410 to determine the relative level of TVOC gases present (see *ZMOD4410 Programming Manual – Read Me*; see also section 12). The algorithm features an automated baseline correction function, ensuring that the module can learn from its environment and distinguish elevated levels of TVOC under all conditions. The proprietary metal oxide (MOx) used in the sensor module allows it to respond effectively to changing TVOC levels during long-term operation.

Renesas has adopted the definition of TVOCs and their impact on user health and comfort proposed by the UBA (see Table 6). The ZMOD4410 can detect the presence of elevated TVOC levels as described in the UBA study.*

There are many sources of poor indoor air quality that can elevate TVOC levels in the typical home or office environments, and the types of TVOC that might be present can vary widely. Additional information on this topic is available in Renesas' *ZMOD4410 White Paper – Overview of TVOC and Indoor Air Quality*.

* Umweltbundesamt, *Beurteilung von Innenraumluftkontaminationen mittels Referenz- und Richtwerten*, (Bundesgesundheitsblatt - Gesundheitsforschung - Gesundheitsschutz, 2007).

The ZMOD4410 can respond reliably to all of the types of organic compounds that are typically found in indoor environments. To assess the response of the gas sensor module to the levels described in the UBA study, the module has been tested using several TO-15/17 multi-component TVOC standards defined by the EPA. The ZMOD4410 response to the EPA standard with the TVOC levels from UBA is shown in Figure 3. A third-party report and certification from an independent research lab is available on the Renesas website that confirms the good conformity for IAQ measurements with respect to the UBA study and EPA standard.

Table 6. Level of Air Quality Based on TVOC Levels Described by UBA

Renesas IAQ Rating	Reference Level ¹	Air Information	TVOC (mg/m ³) ^[a]	Air Quality
≤ 1.99	Level 1	Clean Hygienic Air (target value)	< 0.3	Very Good
2.00 to 2.99	Level 2	Good Air Quality (if no threshold value is exceeded)	0.3 to 1.0	Good
3.00 to 3.99	Level 3	Noticeable Comfort Concerns (not recommended for exposure > 12 months)	1.0 to 3.0	Medium
4.00 to 4.99	Level 4	Significant Comfort Issues (not recommended for exposure > 1 month)	3.0 to 10.0	Poor
≥ 5.00	Level 5	Unacceptable Conditions (not recommended)	> 10.0	Bad

[a] Conversion from mg/m³ to ppm for most common TVOC is by the factor approximately 0.5; for example, 10mg/m³ equals approximately 5ppm. Conversion from ppm to ppb is by the factor 1000; for example, 0.1ppm equals 100ppb.

Figure 3. Typical ZMOD4410 Response to Levels of TVOC Described by UBA using EPA Std. Mixture

Note: TVOC is a subset comprising 25 of the EPA's TO-15/17 certified mixtures.

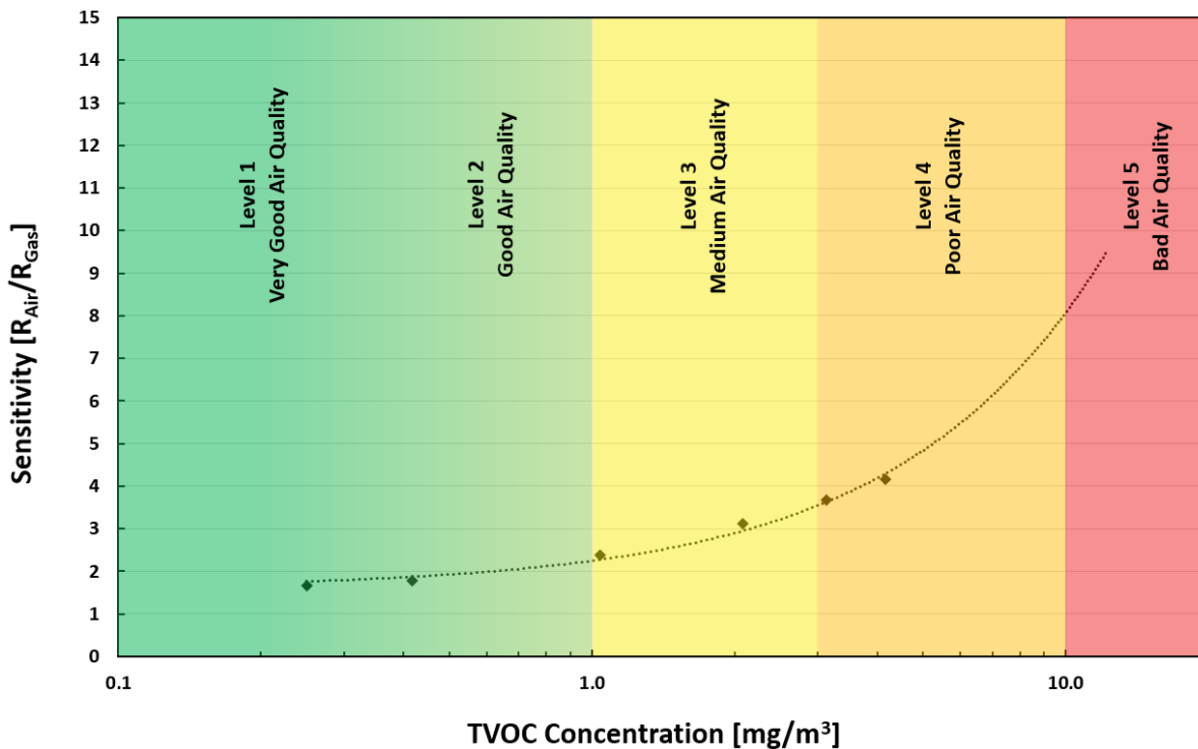

8.1.2 Air Quality – Estimated Carbon Dioxide Correlation (eCO₂)

A very reliable correlation can be made based on TVOC levels for situations where an elevated carbon dioxide (CO₂) concentration is caused by human occupancy, although the sensor module is not directly responsive to CO₂. Renesas has developed a robust, patent pending, correlation between elevated VOCs and CO₂ attributable to human occupancy in a wide variety of living spaces, including homes and offices. The correlation can predict the CO₂ level as shown in Figure 4. Additional details about Renesas' CO₂ correlation are available in the *ZMOD4410 Application Note – Estimating Carbon Dioxide*.

Table 7. Measurement of Estimated CO₂ Levels (eCO₂)

Symbol	Parameter	Conditions	Minimum	Typical	Maximum	Unit
eCO ₂	Estimated CO ₂ Range	Human occupied space (home, office, etc.)	400		5000	ppm
	Estimated CO ₂ Accuracy	Versus reference nondispersive Infrared (NDIR) reference instrument		±25		%

Figure 4. Typical Graph of CO₂ Correlation

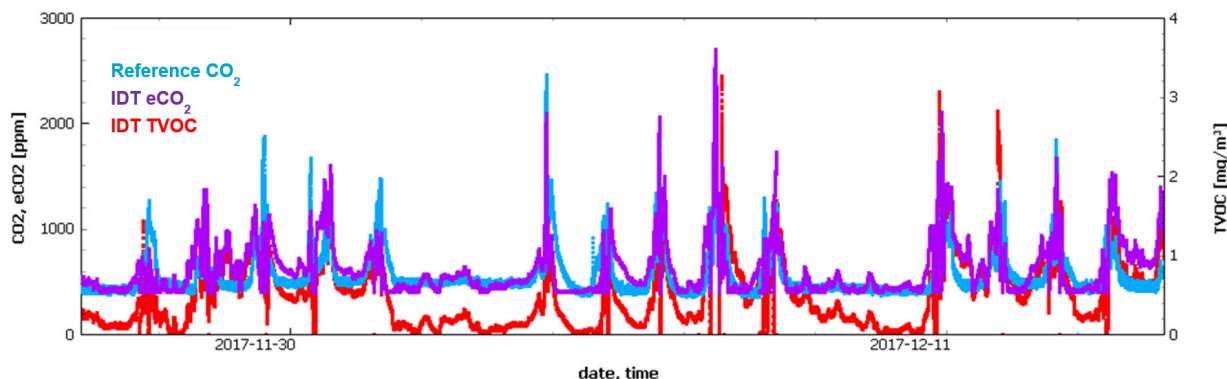

8.2 Operation Mode 4: Odor (Relative Measurement)

Operation Mode 4 can be used to control an external device, such as a fan or ventilation system, based on changes in Air Quality.

Renesas provides firmware and algorithms, which allow the ZMOD4410 to learn its environment. The gas sensor module will only respond to changes in the ambient conditions by detecting changes in the relative ambient TVOC concentration. The sensor module outputs are raw resistance measurements and an algorithmic calculation of the air quality change, which indicates a total air quality change over time. It is defined as the following:

- Air Quality Change < 1: Improvement of air quality, overall gas concentration is falling
- Air Quality Change = 1: No change in air quality
- Air Quality Change > 1: Deterioration of air quality, overall gas concentration is rising

In addition, a control state is given, which shows the status of a user-defined threshold. When a user-defined threshold is exceeded, an I/O control signal (trigger) based on the algorithm output may control an external device. Recommendation: Activate the external device for at least a few minutes (stop delay time) to ensure air quality improvement and avoid an on-off activation at the threshold limit (hysteresis). Depending on the application, you may adjust the threshold trigger and stop delay time.

Table 8. Control Parameters for Odor Operation

Parameter	Conditions	Typical Value	Unit
Learning Time Environment	Typical value valid for sample rate of 2 seconds	60	min
Sensor Module Response Time	Sample rate dependent, typically 1 to 3 samples	5	s

Parameter	Conditions	Typical Value	Unit
Threshold Trigger	Change of raw sensor module signal; recommended difference: 30%	1.3	-
Stop Delay	Stop delay for external device; defines minimum activation time	2	min

When using the ZMOD4410 Evaluation Kit, the AD5 pin (GPIO) on connector K3 on the ZMOD4410 HiCom Communication Board is the trigger control signal output that is set to HIGH/LOW for Operation Mode 4. For more information, see the *ZMOD4410 Evaluation Kit User Manual*.

8.3 Operation Mode 5: Sulfur based Odor Discrimination

Operation Mode 5 can be used to identify if a sulfur-smelling odor is present. When the target gas families have been defined through analysis, a sweeping method allows for chemical discrimination. A machine learning embedded artificial intelligence (AI) algorithm makes use of a MOx surface temperature array to get to a selectivity approach.

This operation mode classifies the odors in "sulfur" (sulfur based) and "acceptable" (organic based) and shows an intensity level of the smell. Acceptable odors are, for example, coming from air refreshers, soaps, perfumes etc., while bad smelling sulfur-based odors come from personal odors in bathrooms. Because impression of smell is very unique, there might be overlaps with how people perceive odors. To bring this in an algorithm, a highly trained Neural Network is using typical chemical signatures from Hydrogen sulfide (H₂S) and Dimethyl sulfide (DMS, C₂H₆S). A range of organic sulfur compounds are considered from the low ppb to the ppm range. The typical sample rate is 3 seconds, but the algorithm may need a few samples for the correct classification.

This sulfur-based odor discrimination firmware was developed based on known commercially available products that represent both bad and acceptable odors. Other places with unknown chemical signatures can lead to incorrect algorithm results. Training the sensor module and developing the discrimination for other gases and applications may be considered for future releases.

8.4 Conditioning and Stability

The ZMOD4410 will respond to TVOC immediately upon start-up; however, a conditioning period of 48 hours followed by a sensor module restart in an ambient environment is recommended to improve stability and obtain maximum performance. Best results are achieved with continuous operation because the module algorithm can learn about the environment over time.

Figure 5 shows the ZMOD4410 sensor module's raw data response to clean air with 30%RH and its response to 5ppm, 10ppm, and 20ppm ethanol mixed in clean air. The result is a very stable, fast changing, and repeatable sensor module signal with a high sensitivity. Signal stability even at high TVOC indoor air quality contaminations is shown in Figure 6.

Figure 5. ZMOD4410 Typical Response Time and Signal Stability for TVOC Exposure

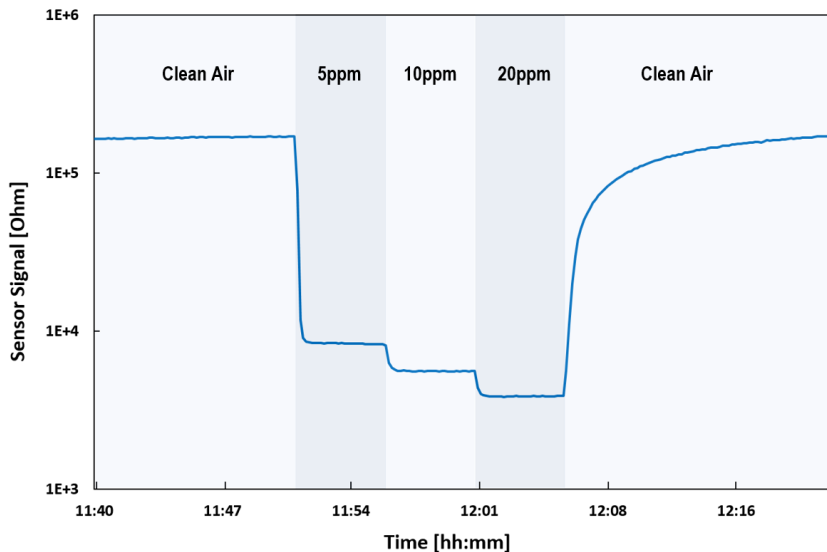
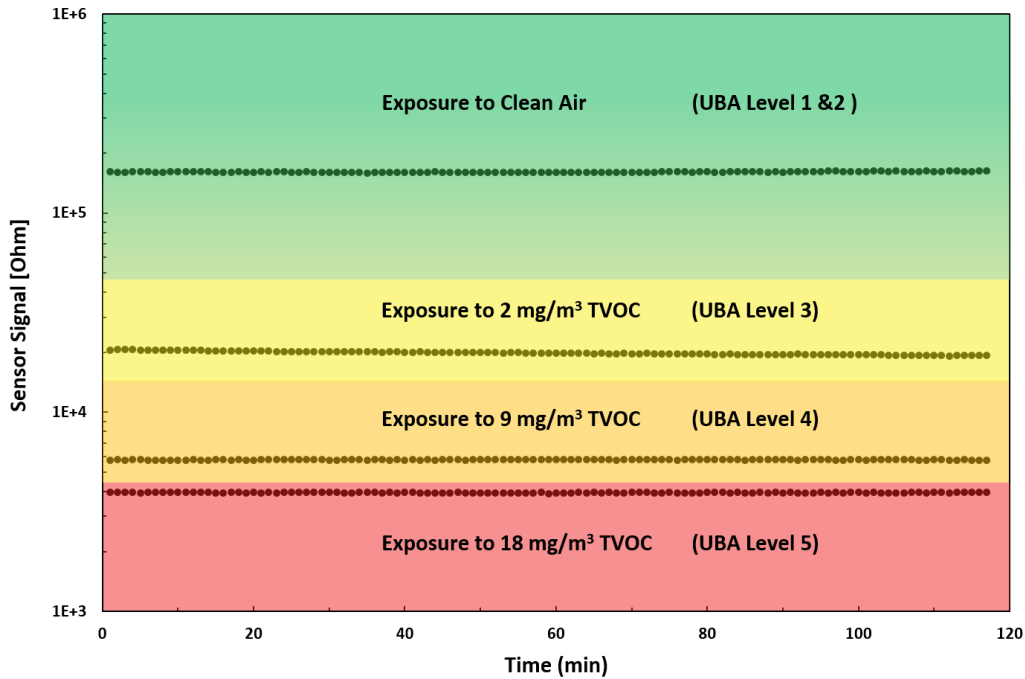

Figure 6. Sensor Module Response to Exposures at Different TVOC Concentrations for 2 Hours Each



8.5 Environmental Temperature and Humidity

Although the ZMOD4410 sensor module is tested, qualified, and functional in the range of -40°C to +65°C, the best performance according to its calibration is achieved in the temperature range of 0°C to +40°C. Figure 7 shows the module's response to variations in the range from 15% to 65% relative humidity for ethanol concentrations mentioned in section 8.3.

Figure 7. Humidity Influence at Three Different VOC Concentrations

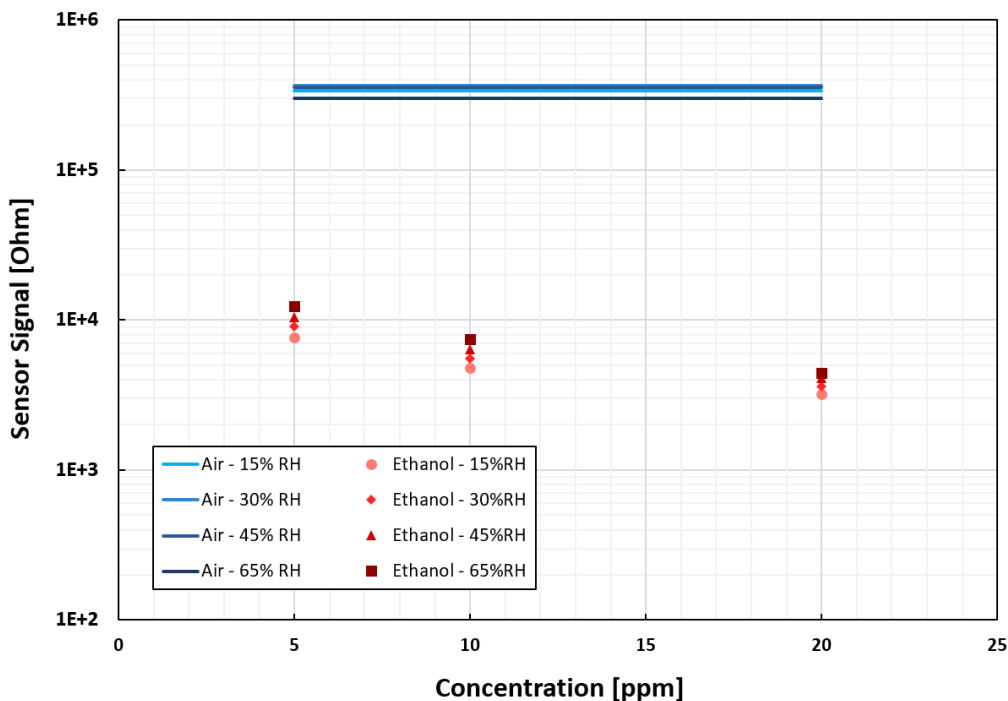

8.6 Accuracy and Consistency

All Renesas gas sensor modules come with electrical and chemical factory calibration with data stored in the module's nonvolatile memory (NVM). Using the software provided by Renesas and the calibration coefficients in the NVM will lead to stable measurement of the UBA level discussed in section 8.1.1 with a maximum deviation of ± 1 category over the module's lifetime.

Typical accuracy and consistency without additional calibration are displayed in Table 9 and in Figure 8. Users who require an absolute measurement with the maximum achievable accuracy are advised to re-calibrate the sensor module with a known organic compound to enable an absolute accuracy of up to $\pm 15\%$. For some environments, an interference response to siloxanes is of concern; however, the ZMOD4410 has proven to be resistant against siloxanes. A maximum potential lifetime exposure has been simulated in all ZMOD4410 operation modes by applying the chemicals D4 (octamethylcyclotetrasiloxane) and D5 (decamethylcyclopentasiloxane) in high concentration for several hundred hours. For more information on test conditions and results, see *ZMOD4410 Application Note – TVOC Sensing*.

Table 9. Typical ZMOD4410 Sensor Module Accuracy Achievable with Calibration

Parameter	Conditions	Minimum	Typical	Maximum	Unit
Accuracy for TVOC	Without additional calibration		± 25		%
	With additional calibration		± 15		%
Accuracy for IAQ	Without additional calibration		± 10		%
Consistency	Part-to-Part Variation		± 25		%
Durability to Siloxanes	Change in sensitivity		± 5		%

Figure 8. Accuracy and Consistency for Eight Sensor Modules

Same Data Set Used for TVOC (Left Plot) and IAQ Levels according to UBA (Right Plot)

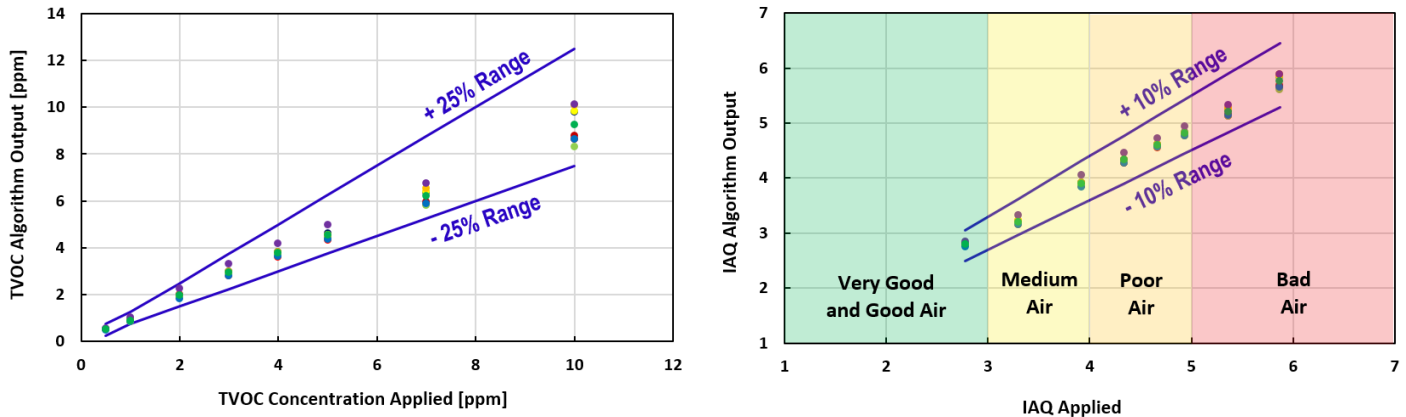

8.7 Sensor Module Algorithm and Firmware

To operate the ZMOD4410, the software and libraries provided by Renesas should be used. The algorithm for the user's microprocessor always uses the raw output signals from the ZMOD4410, which are resistances, to determine the level of gases present. Depending on the microprocessor and compiler used, the firmware and its algorithms require 10 to 20 kB flash size. All algorithms feature an automated baseline correction function, ensuring that the module can learn from its environment and distinguish elevated levels of gases under all conditions. The proprietary metal oxide (MOx) used in the sensor ensures that the sensor module can respond effectively to changing TVOC during long-term operation. Therefore, the user focus should always be on the relevant output parameters: The IAQ index according to UBA, the TVOC concentration (available in mg/m^3 and as Ethanol equivalent in ppm), and/or the estimation of carbon dioxide (eCO_2).

For implementing the sensor module in a customer-specific application, detailed information on the programming is available. More information and guidance on the firmware integration, architecture, and supported platforms are available in the *ZMOD4410 Programming Manual – Read Me*. Code Examples in C and additional firmware descriptions for API, HAL, libraries, etc., are included at no cost in the downloadable firmware package from the [ZMOD4410](#) product page.

9. Assembly Restrictions, Operation, Integration Notes, and Storage

When implementing the ZMOD4410 in electrical circuit boards a gas sensor module might react to chemicals during the assembly process and to outgassing components, such as resins from the printed circuit board (PCB) assembly. A standard soldering profile can be used to assemble the ZMOD4410 on the user's PCB and should fulfill the IPC/JEDEC J-STD-020C Standard ("Moisture/Reflow Sensitivity Classification for Non-hermetic Solid State Surface Mount Devices"). A typical lead-free reflow solder profile is shown in Figure 9. After assembly, an outgassing of the PCB and electronic components must be considered, especially when operating the sensor module at elevated temperatures. This will ultimately influence the sensor module signal and may dominate the air quality reading. A PCB heat treatment before assembling the ZMOD4410 is recommended. After the gas sensor module assembly, no coating, cleaning, or ultrasonic bath should be applied to the PCB. Also, in case sensor module parts are contaminated during assembly or storage, it can be cleaned after assembly by using the cleaning library provided with the firmware to remove any contamination of solder vapor from the MOx surface. In case the sensor module does not show full performance after a cleaning cycle a change to the protection sticker package is recommended (see Ordering Information). Store the sensor module in an antistatic metallic bag with a low VOC background after the sensor module is removed from its original packaging or the assembled PCB is populated. The optimal storage conditions are < 1 ppm TVOC, < 100 ppb O3, < 100 ppb NO2, 10°C to 50°C, and humidity levels within 20% to 80%RH. If the sensor module is stored outside of these conditions for extended periods of time, the readings can exhibit a temporary offset. The sensor module can be reconditioned and brought back to its calibration state by operation for 24 hours to 48 hours in clean air.

To receive the *Renesas Gas Sensor Guidelines* with detailed information and on assembly, material outgassing, test and validation procedures, contact Renesas via the contact information on the last page.

Figure 9. Typical Solder Profile

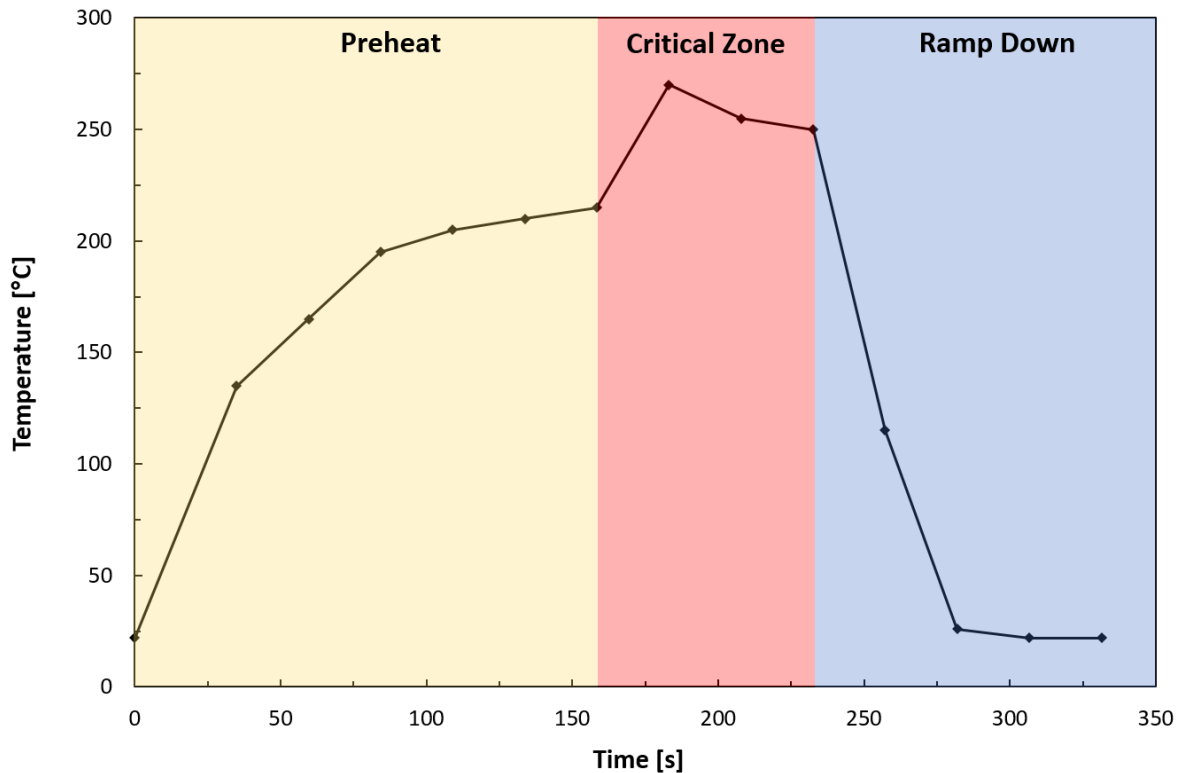

10. Test and Calibration

As a unique feature, all sampled gas sensor modules are fully tested during Renesas' final test. The final test parameters in Table 10 are applied for each ZMOD4410. All sensor modules are pre-stabilized in the final test although the user might see a small change in the module's raw signal during an initial warm-up phase during the first operation. The gas sensor module qualification is based on JEDEC (JESD47) and its subsequent standard (JESD22, JESD78, etc.); it has been tested for a lifetime of 10 years. Renesas has proven a MOx lifetime of over 15+ years in actual continuous operation in conditions without exposures to stressful environments.

Table 10. Final Test Parameters

Test	Test Object	Parameters	Test Results Saved in NVM?
Electrical	ASIC	Voltages, current consumption, frequencies, scan pattern	No
Electrical	Module	Calibration conditions, tracking ID, resistances	Yes
Gas	Module	Sensitivity parameters (slope and intercept) at stimulation with different gas concentrations	Yes
Gas	Module	Pre-stabilization	No

11. I2C Interface and Data Transmission Protocol

The I2C slave device interface supports various bus speeds: Standard Mode ($\leq 100\text{kHz}$) and Fast Mode ($\leq 400\text{kHz}$).

By default, the 7-bit slave address for the serial I2C data interface is set to 32_{HEX}. The implemented data transmission protocol is similar to the one used for conventional EEPROM devices. The register to read/write is selected by a register address pointer. This address pointer must be set during an I2C write operation. For read access a repeated START condition but no STOP condition should be sent. After transmission of a register, the address pointer is automatically incremented. An increment from the address FF_{HEX} rolls over to 00_{HEX}.

For an example of the I2C data transmission protocol, see Figure 10. For information on I2C bus timing, see Figure 11. For I2C bus characteristics, see Table 11, which explains how to set up the interface. All other values are according to the I2C standard. Although the ZMOD4410 has an I2C interface, the user is not intended to modify any registers because a configuration change will affect the sensor module's performance, reliability, and accuracy. The API provided with the downloadable firmware package on the website manages all necessary sensor module communication.

To validate the general MCU-specific I2C read/write driver without the use of Renesas libraries, it is possible to write random values to registers 0x88 to 0x8B and read them afterwards. After this register testing, erase the testing code and reset the device by disconnecting the power support; otherwise the device may not operate properly.

Figure 10. I2C Data Transmission Protocol

WRITE Access RAM

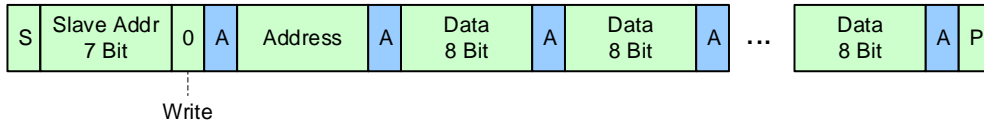

READ Access NVM and RAM

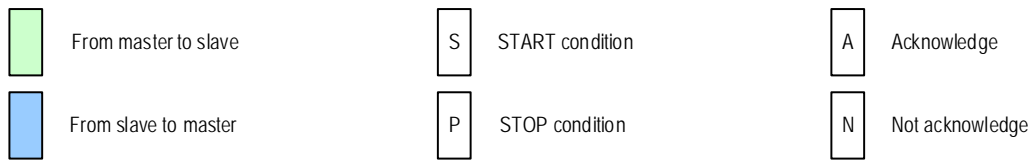
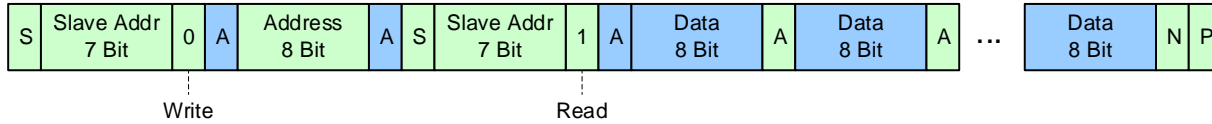

Figure 11. Bus Timing

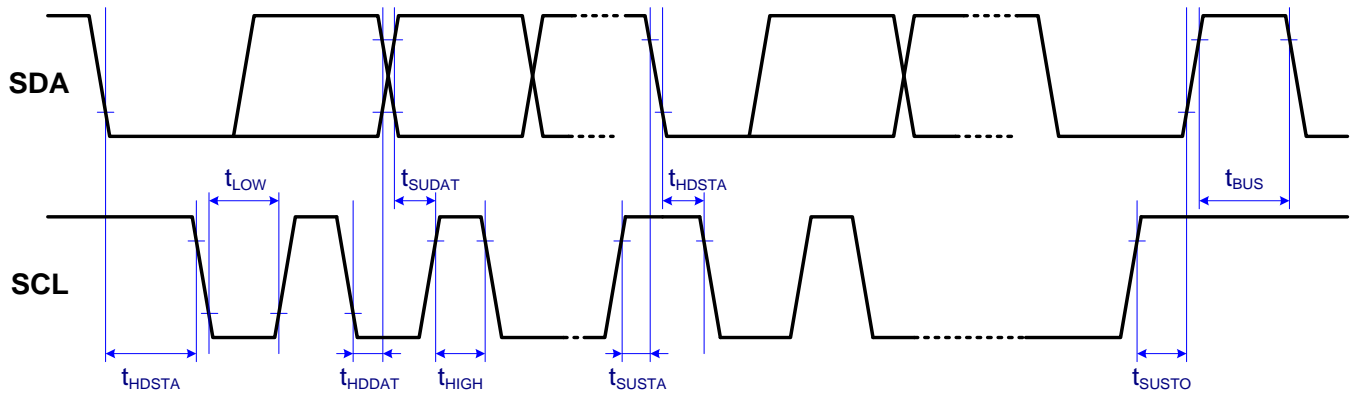

Table 11. Bus Timing Characteristic

Parameter	Symbol	Standard Mode	Fast Mode	Units
Maximum SCL clock frequency	f_{SCL}	100	400	kHz
Minimum START condition hold time relative to SCL edge	t_{HDSTA}	4		μs
Minimum SCL clock low width	t_{LOW}	4.7		μs
Minimum SCL clock high width	t_{HIGH}	4		μs
Minimum START condition setup time relative to SCL edge	t_{SUSTA}	4.7		μs
Minimum data hold time on SDA relative to SCL edge	t_{HDDAT}	0		μs
Minimum data setup time on SDA relative to SCL edge	t_{SUDAT}	0.1	0.1	μs
Minimum STOP condition setup time on SCL	t_{SUSTO}	4		μs
Minimum bus free time between stop condition and start condition	t_{BUS}	4.7		μs

12. Related Websites and Software

Visit the [ZMOD4410](#) and [ZMOD4410 Evaluation Kit](#) (ZMOD4410-EVK) webpages on the Renesas website to download software and the latest version of related documents, such as application notes, white papers, product briefs, and third-party reports.

Note that some documents require logging in with a free customer account, which can be set up under the “LOG IN” button on www.renesas.com. Some downloads require an additional step to complete a request form that appears when the link is clicked.

If additional support is needed for downloading, contact Renesas via the contact information on the last page.

13. Glossary

Term	Description
ADC	Analog-to-Digital Converter
AI	Artificial Intelligence
CDM	Charged Device Model
CM	Common Mode Generator
HBM	Human Body Model
IAQ 1 st Gen	Indoor Air Quality algorithm using traditional computing methods
IAQ 2 nd Gen	Indoor Air Quality algorithm using machine learning AI
LGA	Land Grid Array
LV	Low Voltage
MOx	Metal Oxide
MSL	Moisture Sensitivity Level
Mux	Multiplexer
n.a.	Not Applicable
NVM	Nonvolatile Memory
POR	Power-On Reset
SDA	Serial Data
SCL	Serial Clock
SSC	Sensor Signal Conditioner
TST	Test
TVOC	Total Volatile Organic Compounds
UBA	Umweltbundesamt (German Federal Environmental Agency)

14. Package Outline Drawings

The ZMOD4410's different packages are listed in Table 12.

Table 12. Package Options

Part Number	Version	Comment	Package Link
ZMOD4410AI1	Standard	Standard package	LGG12D1 package
ZMOD4410AI2	Sticker	This package shipped with a sticker on top of the lid to protect sensor during assembly. Note, the sticker has to be removed after assembly.	
ZMOD4410AI3	Waterproof	This package uses a membrane to get IP67 rating	LGG12D2 package
ZMOD4410AI4	Waterproof + Sticker	This package uses a membrane to get IP67 rating and is shipped with a sticker on top of the lid to protect sensor during assembly. Note, the sticker has to be removed after assembly.	

15. Marking Diagram

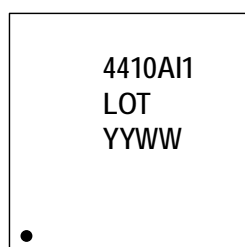

1. Line 1 is the truncated part number.
2. Line 2 – “LOT” denotes the assembly lot number.
3. Line 2 – “YYWW” are the last two digit of the year and week that the part was assembled.

16. Ordering Information

Part Number	Description and Package	MSL Rating	Carrier Type	Temp. Range
ZMOD4410AI1V	ZMOD4410 Sensor Module, 3.0 × 3.0 × 0.7 mm 12-LGA	3	Tray	-40°C to +65°C
ZMOD4410AI1R	ZMOD4410 Sensor Module, 3.0 × 3.0 × 0.7 mm 12-LGA	3	Reel	-40°C to +65°C
ZMOD4410AI2V	ZMOD4410 Sensor Module, 3.0 × 3.0 × 0.7 mm 12-LGA, shipped with <i>removable protection sticker</i>	3	Tray	-40°C to +65°C
ZMOD4410AI2R	ZMOD4410 Sensor Module, 3.0 × 3.0 × 0.7 mm 12-LGA, shipped with <i>removable protection sticker</i>	3	Reel	-40°C to +65°C
ZMOD4410AI3V	ZMOD4410 Sensor Module, 3.0 × 3.0 × 0.9 mm 12-LGA, <i>IP67 rating</i>	3	Tray	-40°C to +65°C
ZMOD4410AI3R	ZMOD4410 Sensor Module, 3.0 × 3.0 × 0.9 mm 12-LGA <i>IP67 rating</i>	3	Reel	-40°C to +65°C
ZMOD4410AI4V	ZMOD4410 Sensor Module, 3.0 × 3.0 × 0.9 mm 12-LGA, shipped with removable protection sticker and IP67 rating	3	Tray	-40°C to +65°C
ZMOD4410AI4R	ZMOD4410 Sensor Module, 3.0 × 3.0 × 0.9 mm 12-LGA, shipped with removable protection sticker and IP67 rating	3	Reel	-40°C to +65°C

Part Number	Description and Package	MSL Rating	Carrier Type	Temp. Range
ZMOD4410-EVK-HC	ZMOD4410 Evaluation Kit including the ZMOD4410 Sensor Board, ZMOD4410 HiCom Communication Board (USB Interface), and Micro-USB Cable. (The ZMOD4410 Evaluation Software is available for download free of charge on the ZMOD4410-EVK webpage.)			
ZMOD4410-EVK-HC-WP	ZMOD4410 Evaluation Kit including the ZMOD4410 Sensor Board with IP67 rating, ZMOD4410 HiCom Communication Board (USB Interface), and Micro-USB Cable. (The ZMOD4410 Evaluation Software is available for download free of charge on ZMOD4410-EVK webpage.)			

17. Revision History

Revision Date	Description of Change
June 30, 2021	<ul style="list-style-type: none"> ▪ Updated improved lifetime ▪ Added a description of firmware and algorithms ▪ Add a marking diagram ▪ Updated URL
November 30, 2020	<ul style="list-style-type: none"> ▪ Updated “Conditioning and Stability” ▪ Completed minor changes throughout
November 2, 2020	<ul style="list-style-type: none"> ▪ Added ZMOD4410 sensor module packages for Assembly Protection and IP67 Rating ▪ Minor updates in language
June 3, 2020	<ul style="list-style-type: none"> ▪ Completed minor edits.
June 1, 2020	<ul style="list-style-type: none"> ▪ Changed to Renesas layout ▪ Added RoHS compliance ▪ Updated NVM data space ▪ Updated with Operation Mode for IAQ 2nd Gen ▪ Updated with Operation Mode for Sulfur based odor discrimination
July 30, 2019	<ul style="list-style-type: none"> ▪ MSL rating corrected in the Ordering table.
May 9, 2019	<ul style="list-style-type: none"> ▪ Addition of storage conditions. ▪ Improved programming description for customer-specific applications. ▪ Improved pin description for INT. ▪ Addition of lifetime for qualification. ▪ Addition of the “Related Website and Software” section.
March 12, 2019	<ul style="list-style-type: none"> ▪ Update to add I2C specification. ▪ Update figure for humidity influence. ▪ Update to add disclaimer for safety-related applications in section 7.1. ▪ Minor edits.
November 2, 2018	<ul style="list-style-type: none"> ▪ Update with Low Power Operation Method.
September 24, 2018	<ul style="list-style-type: none"> ▪ Update for operation methods for trigger/control signal option. ▪ Update for power consumption and minor update in electrical characteristics. ▪ Update references.
September 1, 2018	Initial release.

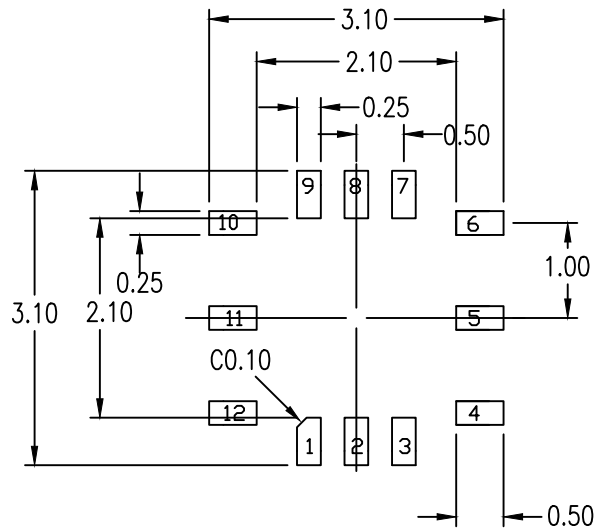

RECOMMENDED LAND PATTERN DIMENSION

NOTES:

1. ALL DIMENSION ARE IN MM. ANGLES IN DEGREES.
2. TOP DOWN VIEW. AS VIEWED ON PCB.
3. NSMD LAND PATTERN ASSUMED.
4. LAND PATTERN RECOMMENDATION PER IPC-7351B GENERIC REQUIREMENT FOR SURFACE MOUNT DESIGN AND LAND PATTERN.

Package Revision History

Date Created	Rev No.	Description
Sept 12, 2019	Rev 01.	Add Dimension on Gal Inlet Hole
Dec 17, 2019	Rev 02	Add Location Dimension Gal Inlet
Mar 10, 2021	Rev 03	Add Tolerance for Entire Body

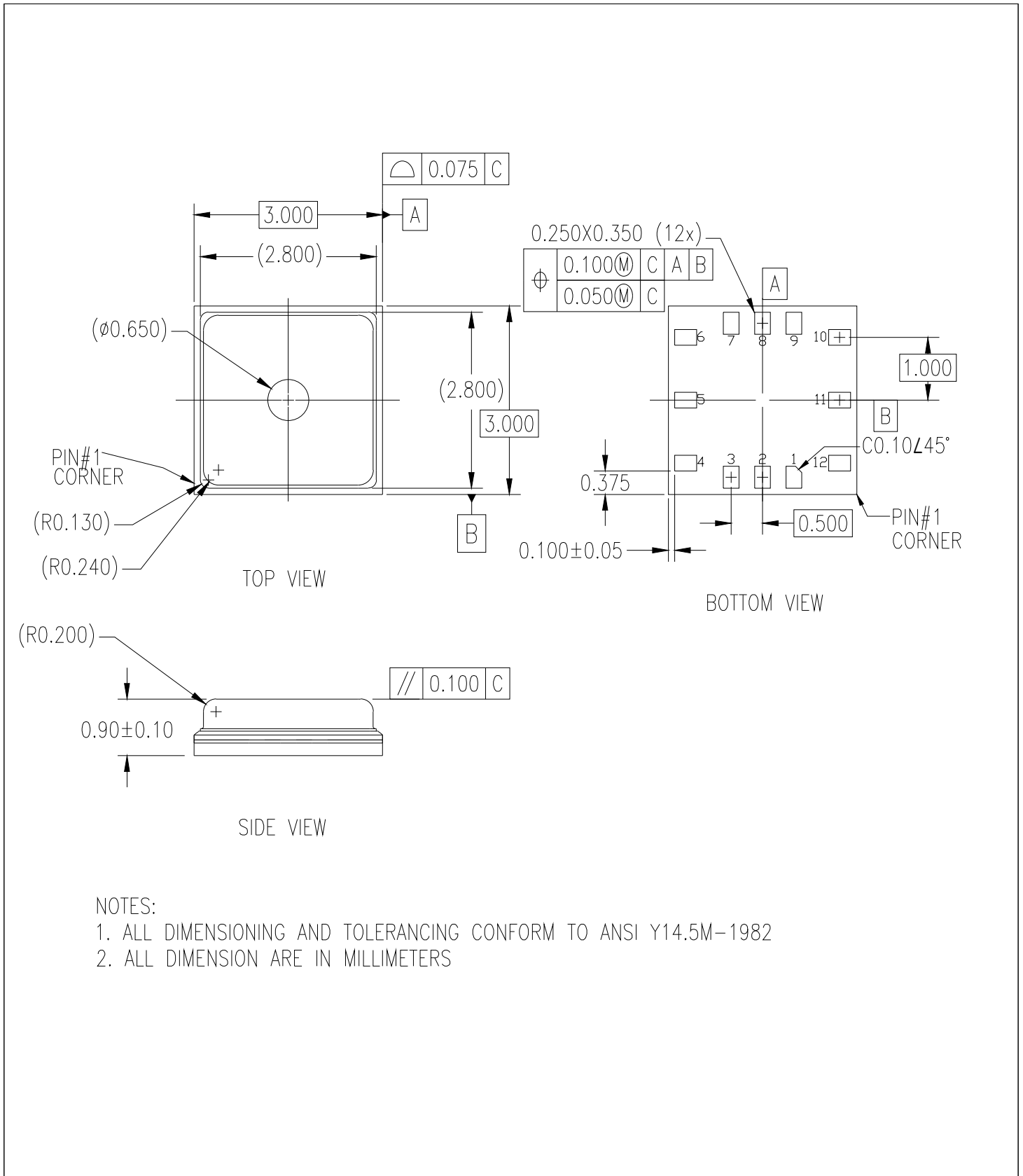

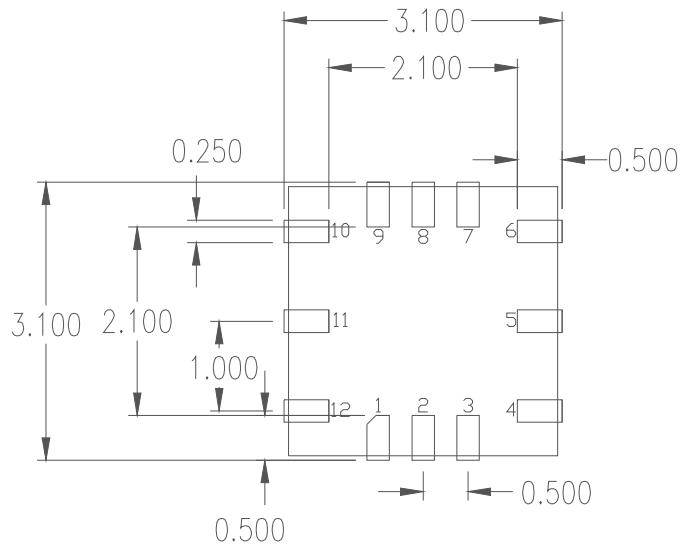

RECOMMENDED LAND PATTERN DIMENSION

NOTES:

1. ALL DIMENSION ARE IN MM. ANGLES IN DEGREES
2. TOP DOWN VIEW ON PCB
3. LAND PATTERN RECOMMENDATION PER IPC-7351B GENERIC REQUIREMENT FOR SURFACE MOUNT DESIGN AND LAND PATTERN

Date Created	Rev No.	Package Revision History
April 24, 2020	Rev 00	Initial release

IMPORTANT NOTICE AND DISCLAIMER

RENESAS ELECTRONICS CORPORATION AND ITS SUBSIDIARIES (“RENESAS”) PROVIDES TECHNICAL SPECIFICATIONS AND RELIABILITY DATA (INCLUDING DATASHEETS), DESIGN RESOURCES (INCLUDING REFERENCE DESIGNS), APPLICATION OR OTHER DESIGN ADVICE, WEB TOOLS, SAFETY INFORMATION, AND OTHER RESOURCES “AS IS” AND WITH ALL FAULTS, AND DISCLAIMS ALL WARRANTIES, EXPRESS OR IMPLIED, INCLUDING, WITHOUT LIMITATION, ANY IMPLIED WARRANTIES OF MERCHANTABILITY, FITNESS FOR A PARTICULAR PURPOSE, OR NON-INFRINGEMENT OF THIRD PARTY INTELLECTUAL PROPERTY RIGHTS.

These resources are intended for developers skilled in the art designing with Renesas products. You are solely responsible for (1) selecting the appropriate products for your application, (2) designing, validating, and testing your application, and (3) ensuring your application meets applicable standards, and any other safety, security, or other requirements. These resources are subject to change without notice. Renesas grants you permission to use these resources only for development of an application that uses Renesas products. Other reproduction or use of these resources is strictly prohibited. No license is granted to any other Renesas intellectual property or to any third party intellectual property. Renesas disclaims responsibility for, and you will fully indemnify Renesas and its representatives against, any claims, damages, costs, losses, or liabilities arising out of your use of these resources. Renesas' products are provided only subject to Renesas' Terms and Conditions of Sale or other applicable terms agreed to in writing. No use of any Renesas resources expands or otherwise alters any applicable warranties or warranty disclaimers for these products.

(Rev.1.0 Mar 2020)

Corporate Headquarters

TOYOSU FORESIA, 3-2-24 Toyosu,
Koto-ku, Tokyo 135-0061, Japan
www.renesas.com

Contact Information

For further information on a product, technology, the most up-to-date version of a document, or your nearest sales office, please visit:
www.renesas.com/contact/

Trademarks

Renesas and the Renesas logo are trademarks of Renesas Electronics Corporation. All trademarks and registered trademarks are the property of their respective owners.

X-ON Electronics

Largest Supplier of Electrical and Electronic Components

Click to view similar products for [Multiple Function Sensor Development Tools](#) category:

Click to view products by [Renesas](#) manufacturer:

Other Similar products are found below :

[MAXWSNENV#](#) [STEVAL-MKIT01V1](#) [KT-O2-25%-TB200A-E](#) [KT-TVOC-200-TB200A](#) [KT-NmHc-200-TB200A](#) [SEN0344](#) [PIM520](#)
[PIM518](#) [PIM519](#) [PIM502](#) [AS7022-EVALKIT](#) [ALTEHTG2SMIP](#) [MAX30101WING#](#) [OB1203SD-U-EVK](#) [MIKROE-4265](#) [A000070](#)
[EV_ICG-20660L](#) [GX-F12A-P](#) [GX-F15A](#) [GX-F8AI-P](#) [GX-H15AI-P](#) [GX-H6A-P](#) [GX-HL15B-P](#) [1093](#) [MIKROE-2455](#) [MIKROE-2458](#)
[MIKROE-2507](#) [MIKROE-2508](#) [MIKROE-2516](#) [MIKROE-2529](#) [1458](#) [MIKROE-1628](#) [176](#) [189](#) [1893](#) [2106](#) [ATQT4-XPRO](#) [GP30-DEMO](#)
[MODULE](#) [GX-F12AI-P](#) [GX-F15A-P](#) [GX-FL15B-P](#) [GX-H12AI-P](#) [GX-H15A-P](#) [GX-H6AI-P](#) [GX-H8A-P](#) [GX-F15AI-P](#) [GX-FL15A-P](#) [AAS-](#)
[AQS-UNO](#) [DFR0018](#) [DFR0131](#)