

Brief Description

The ZSSC3224 is a sensor signal conditioner (SSC) IC for high-accuracy amplification and analog-to-digital conversion of a differential or pseudo-differential input signal. Designed for high resolution sensor module applications, the ZSSC3224 can perform offset, span, and 1st and 2nd order temperature compensation of the measured signal. Developed for correction of resistive bridge or absolute voltage sensors, it can also provide a corrected temperature output measured with an internal sensor.

The measured and corrected sensor values are provided at the digital output pins, which can be configured as I2C ($\leq 3.4\text{MHz}$) or SPI ($\leq 20\text{MHz}$). Digital compensation of signal offset, sensitivity, temperature, and non-linearity is accomplished via a 26-bit internal digital signal processor (DSP) running a correction algorithm. Calibration coefficients are stored on-chip in a highly reliable, non-volatile, multiple-time programmable (MTP) memory. Programming the ZSSC3224 is simple via the serial interface. The interface is used for the PC-controlled calibration procedure, which programs the set of calibration coefficients in memory. The ZSSC3224 provides accelerated signal processing, increased resolution, and improved noise immunity in order to support high-speed control, safety, and real-time sensing applications with the highest requirements for energy efficiency.

Applications

- Barometric altitude measurement for portable navigation or emergency call systems; altitude measurement for car navigation
- Weather forecast
- Fan control
- Industrial, pneumatic, and liquid pressure
- High-resolution temperature measurements
- Object-temperature radiation (via thermopile)

ZSSC3224 Application Example

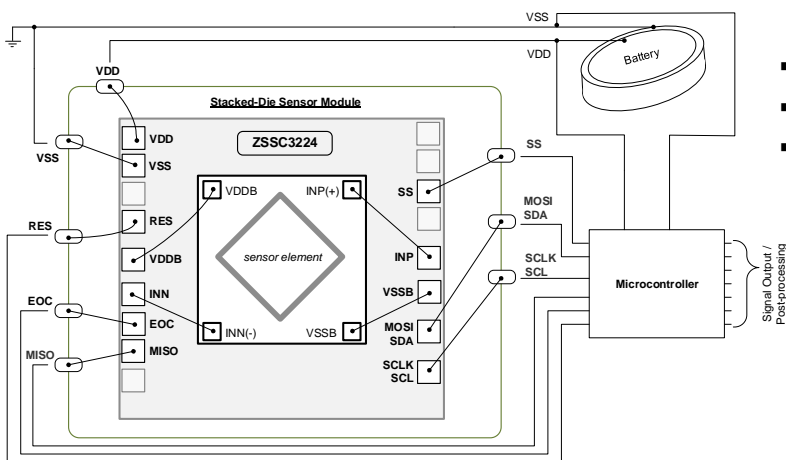

Features

- Flexible, programmable analog front-end design; up to 24-bit analog-to-digital converter (ADC)
- Fully programmable gain amplifier for optimizing sensor signals: gain range 6.6 to 216 (linear)
- Internal auto-compensated 18-bit temperature sensor
- Digital compensation of individual sensor offset; 1st and 2nd order digital compensation of sensor gain as well as 1st and 2nd order temperature gain and offset drift
- Programmable interrupt operation
- High-speed sensing: e.g., 18-bit conditioned sensor signal measurement rate $>200\text{s}^{-1}$
- Typical sensor elements can achieve an accuracy of better than $\pm 0.10\%$ full scale output (FSO) at -40 to 85°C
- Integrated 26-bit calibration math digital signal processor (DSP)
- Fully corrected signal at digital output
- Layout customized for die-die bonding with sensor for high-density chip-on-board assembly
- One-pass calibration minimizes calibration costs
- No external trimming, filter, or buffering components required
- Highly integrated CMOS design
- Integrated reprogrammable non-volatile memory
- Excellent for low-voltage and low-power battery applications
- Optimized for operation in calibrated resistive (e.g., pressure) sensor or calibrated absolute voltage (e.g., thermopile) sensor modules
- Supply voltage range: 1.68V to 3.6V
- Operating mode current: $\sim 1.0\text{mA}$ (typical)
- Sleep Mode current: 20nA (typical)
- Temperature resolution: $<0.7\text{mK/LSB}$
- Excellent energy-efficiency:
 - with 18-bit resolution: $<100\text{pJ/step}$
 - with 24-bit resolution: $<150\text{nJ/step}$
- Small die size
- Operation temperature: -40°C to $+85^\circ\text{C}$
- Delivery options: 4.0mm x 4.0mm 24-PQFN and die for wafer bonding

ZSSC3224 Block Diagram

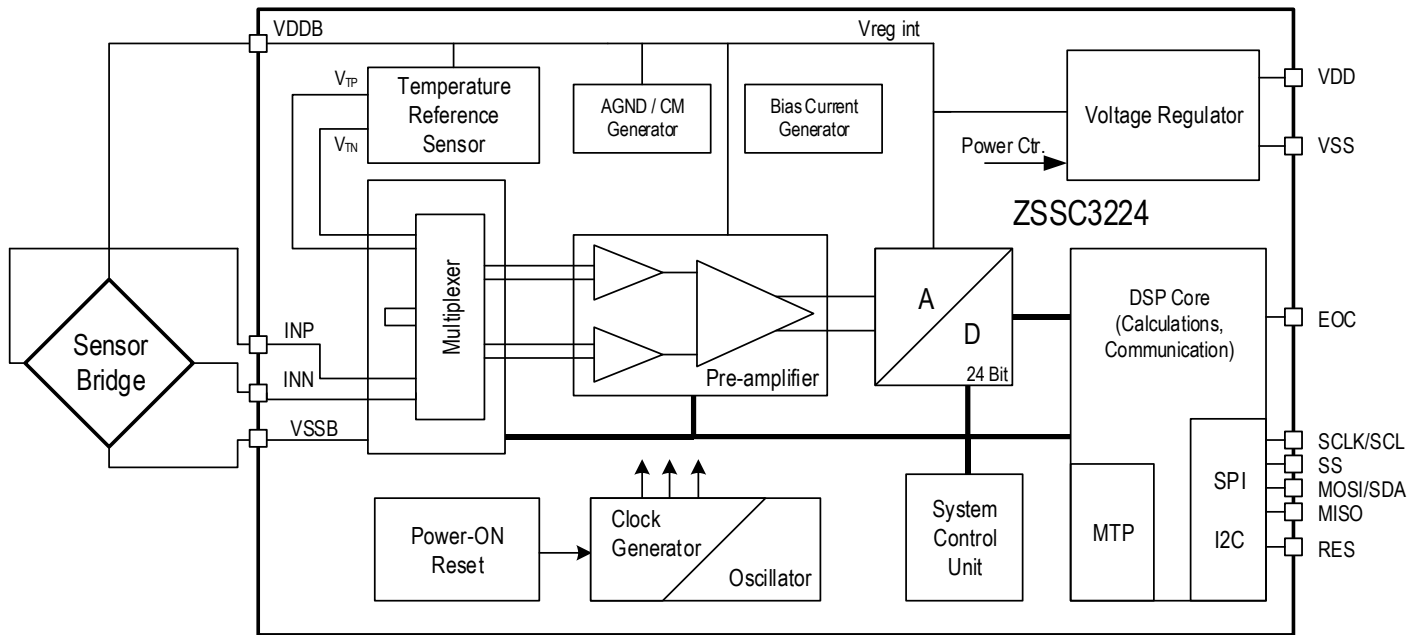

Contents

1.	Pin and Pad Assignments and Descriptions.....	6
1.1	ZSSC3224 Die Pad Assignments and Descriptions.....	6
1.2	ZSSC3224 24-PQFN Pin Assignments and Pin Descriptions	7
2.	Absolute Maximum Ratings.....	8
3.	Recommended Operating Conditions	9
4.	Electrical Characteristics	10
4.1	Power Supply Rejection Ratio (PSRR) versus Frequency	11
5.	Circuit Description	12
5.1	Brief Description	12
5.2	Signal Flow and Block Diagram.....	12
5.3	Analog Front End.....	13
5.3.1	Amplifier.....	13
5.3.2	Analog-to-Digital Converter	15
5.3.3	Selection of Gain and Offset – Sensor System Dimensioning.....	17
5.3.4	Temperature Measurement	18
5.3.5	External Sensor Supply: Bridge Sensors.....	18
5.3.6	External Sensor: Absolute Voltage Source Sensors	18
5.4	Digital Section.....	19
5.4.1	Digital Signal Processor (DSP) Core.....	19
5.4.2	MTP Memory	19
5.4.3	Clock Generator	19
5.4.4	Power Supervision.....	19
5.4.5	Interface.....	19
6.	Functional Description	20
6.1	Power Up.....	20
6.2	Measurements.....	20
6.3	Interrupt (EOC Pin).....	20
6.4	Operational Modes	21
6.4.1	SPI/I2C Commands.....	24
6.5	Communication Interface.....	26
6.5.1	Common Functionality.....	26
6.5.2	SPI.....	27
6.5.3	I2C.....	30
6.6	Multiple Time Programmable (MTP) Memory.....	31
6.6.1	Programming Memory	31
6.6.2	Memory Contents	32
6.7	Calibration Sequence	37
6.7.1	Calibration Step 1 – Assigning Unique Identification	37
6.7.2	Calibration Step 2 – Data Collection.....	37

6.7.3	Calibration Step 3a) – Coefficient Calculations	38
6.7.4	Calibration Step 3b) – Post-Calibration Offset Correction	38
6.7.5	SSC Measurements	39
6.8	The Calibration Math	39
6.8.1	Bridge Signal Compensation	39
6.8.2	Temperature Signal Compensation	41
6.8.3	Measurement Output Data Format	42
7.	Package Outline Drawings	43
7.1	ZSSD3224 Die Dimensional Drawings	43
7.2	24-PQFN Package Dimensions	44
8.	Quality and Reliability	45
9.	Related Documents	45
10.	Glossary	45
11.	Marking Diagram	46
12.	Ordering Information	46
13.	Document Revision History	47

List of Figures

Figure 1.1	ZSSC3224 Die Pad Assignments	6
Figure 1.2	Pin Assignments: 4.0 × 4.0 × 0.85 mm 24-PQFN Package	7
Figure 5.1	ZSSC3224 Functional Block Diagram with Resistive-Bridge Sensor	12
Figure 5.2	ZSSC3224 Functional Block Diagram with Voltage-Source Sensor	13
Figure 5.3	ADC Gain and Offset Setup	18
Figure 6.1	Interrupt Functionality	21
Figure 6.2	Operational Flow Chart: Power Up	22
Figure 6.3	Operational Flow Chart: Command Mode and Normal Mode (Sleep and Cyclic)	23
Figure 6.4	SPI Configuration CPHA=0	28
Figure 6.5	SPI Configuration CPHA=1	28
Figure 6.6	SPI Command Request	29
Figure 6.7	SPI Read Status	29
Figure 6.8	SPI Read Data	29
Figure 6.9	I2C Command Request	30
Figure 6.10	I2C Read Status	30
Figure 6.11	I2C Read Data	30
Figure 7.1	Approximate ZSSC3224 Pad Layout	43
Figure 7.2	General 24-PQFN Package Dimensions	44

List of Tables

Table 1.1	ZSSC3224 Die Pad Assignments.....	6
Table 1.2	ZSSC3224 Pin Descriptions: 24-PQFN Package.....	7
Table 2.1	Absolute Maximum Ratings.....	8
Table 3.1	Recommended Operating Conditions	9
Table 3.2	Requirements for VDD Power-on Reset.....	9
Table 4.1	Electrical Characteristics	10
Table 5.1	Amplifier Gain: Stage 1.....	14
Table 5.2	Amplifier Gain: Stage 2.....	14
Table 5.3	Gain Polarity.....	14
Table 5.4	ADC Conversion Times for a Single Analog-to-Digital Conversion	15
Table 5.5	ADC Offset Shift.....	16
Table 5.6	Typical Conversion Times versus Noise Performance with Full Sensor Signal Conditioning for Measurement including AZSM, SM, AZTM, and TM (Bridge-Type Sensor).....	16
Table 6.1	SPI/I2C Commands.....	24
Table 6.2	Get_Raw Commands	26
Table 6.3	General Status Byte	27
Table 6.4	Mode Status	27
Table 6.5	MTP Memory Content Assignments.....	32
Table 6.6	Measurement Results of ADC Raw Measurement Request (Two's Complement)	42
Table 6.7	Calibration Coefficients (Factors and Summands) in Memory (Sign Magnitude)	42
Table 6.8	Output Results from SSC-Correction Math or DSP—Sensor and Temperature	42
Table 6.9	Interrupt Thresholds TRSH1 and TRSH2—Format as for SSC-Correction Math Output.....	42
Table 7.1	Physical Package Dimensions	44

1. Pin and Pad Assignments and Descriptions

The ZSSC3224 is available in die form or in the 24-PQFN package.

1.1 ZSSC3224 Die Pad Assignments and Descriptions

Figure 1.1 ZSSC3224 Die Pad Assignments

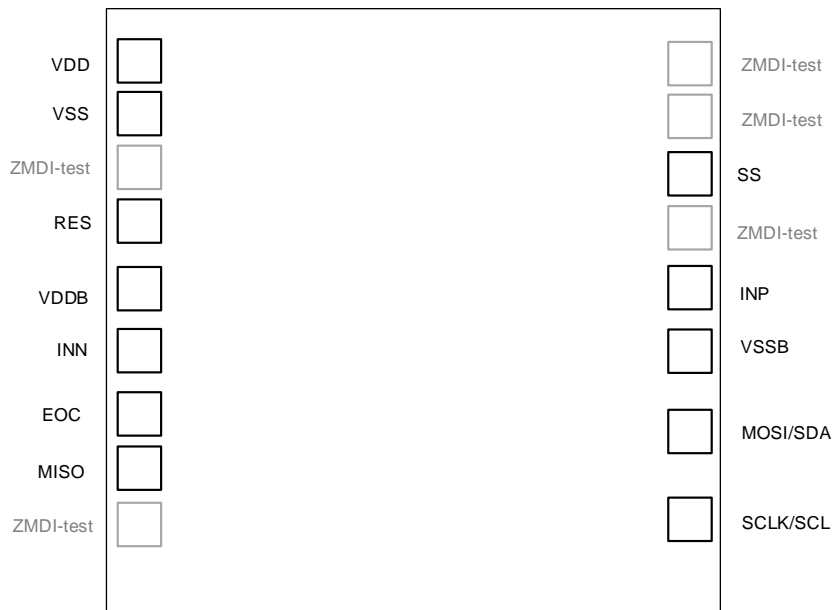

Table 1.1 ZSSC3224 Die Pad Assignments

Name	Direction	Type	Description
VDD	IN	Supply	Positive supply voltage for the ZSSC3224.
VSS	IN	Supply	Ground reference voltage signal.
RES	IN	Digital	ZSSC3224 reset (low active, internal pull-up).
VDDB	OUT	Analog	Positive external bridge-sensor supply.
INN	IN	Analog	Negative sensor signal (or sensor-ground for absolute voltage-sources sensors).
EOC	OUT	Digital	End of conversion or interrupt output.
MISO	OUT	Digital	Data output for SPI.
SS	IN	Digital	Slave select for SPI.
INP	IN	Analog	Positive sensor signal.
VSSB	OUT	Analog	Negative external bridge-sensor supply (sensor ground).
MOSI/SDA	IN/OUT	Digital	Data input for SPI; data in/out for I2C.
SCLK/SCL	IN	Digital	Clock input for SPI/I2C.
ZMDI-test	–	–	Do not connect to these pads.

1.2 ZSSC3224 24-PQFN Pin Assignments and Pin Descriptions

Figure 1.2 Pin Assignments: 4.0 × 4.0 × 0.85 mm 24-PQFN Package

Note: Drawing is not to scale. See section 7 for dimensions.

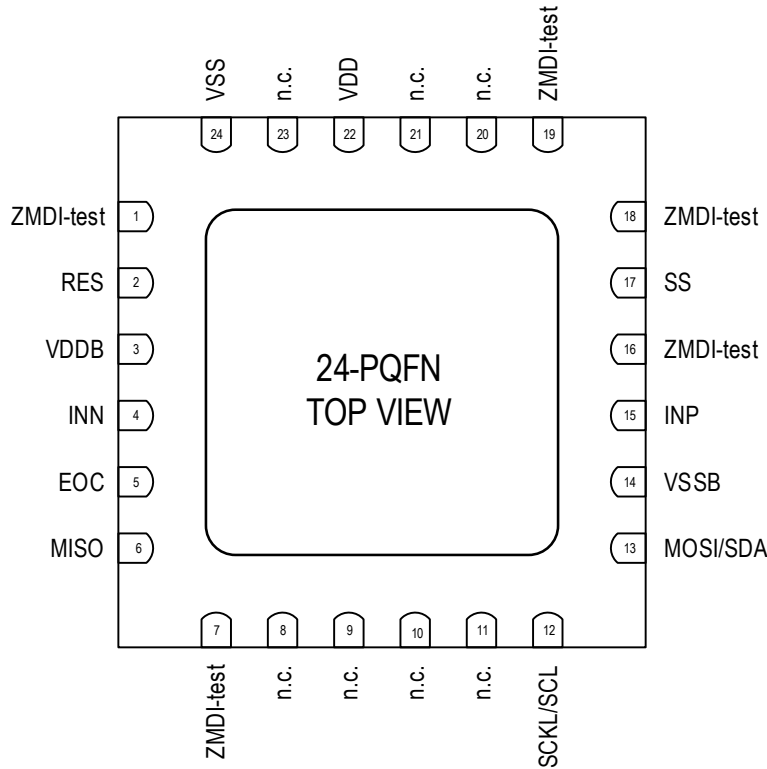

Table 1.2 ZSSC3224 Pin Descriptions: 24-PQFN Package

Note: In the following table, “n.c.” stands for not connected / no connection required / not bonded.

Pin No.	Name	Direction	Type	Description
1	ZMDI-test	–	–	Do not connect.
2	RES	IN	Digital	ZSSC3224 reset (low active, internal pull-up).
3	VDDDB	OUT	Analog	Positive external bridge-sensor supply.
4	INN	IN	Analog	Negative sensor signal (or sensor ground for absolute voltage-source sensors).
5	EOC	OUT	Digital	End of conversion or interrupt output.
6	MISO	OUT	Digital	Data output for SPI.
7	ZMDI-test	–	–	Do not connect.
8	n.c.	–	–	–
9	n.c.	–	–	–
10	n.c.	–	–	–
11	n.c.	–	–	–

Pin No.	Name	Direction	Type	Description
12	SCLK/SCL	IN	Digital	Clock input for SPI/I2C.
13	MOSI/SDA	IN/OUT	Digital	Data input for SPI; data in/out for I2C.
14	VSSB	OUT	Analog	Negative external bridge-sensor supply (sensor ground).
15	INP	IN	Analog	Positive sensor signal.
16	ZMDI-test	–	–	Do not connect.
17	SS	IN	Digital	Slave select for SPI
18	ZMDI-test	–	–	Do not connect.
19	ZMDI-test	–	–	Do not connect.
20	n.c.	–	–	–
21	n.c.	–	–	–
22	VDD	IN	Supply	Positive supply voltage for the ZSSC3224.
23	n.c.	–	–	–
24	VSS	IN	Supply	Ground reference voltage signal.
25	Exposed Pad	–	–	Do not connect electrically.

2. Absolute Maximum Ratings

Note: The absolute maximum ratings are stress ratings only. The ZSSC3224 might not function or be operable above the recommended operating conditions. Stresses exceeding the absolute maximum ratings might also damage the device. In addition, extended exposure to stresses above the recommended operating conditions might affect device reliability. IDT does not recommend designing to the “Absolute Maximum Ratings.”

Table 2.1 Absolute Maximum Ratings

PARAMETER	SYMBOL	Min	TYP	MAX	UNITS
Voltage Reference	V _{SS}	0		0	V
Analog Supply Voltage	V _{DD}	-0.4		3.63	V
Voltage at all Analog and Digital IO Pins	V _{A_IO} , V _{D_IO}	-0.5		V _{DD} +0.5	V
Input Current into Any Pin except RES, ZMDI-test, SS [a], [b]	I _{IN}	-100		100	mA
Electrostatic Discharge Tolerance – Human Body Model (HBM1) [c]	V _{HBM1}	±4000		-	V
Storage Temperature	T _{STOR}	-50		150	°C

[a] Latch-up current limit for RES, ZMDI-test, and SS: ±70mA.

[b] Latch-up resistance; reference for pin is 0V.

[c] HBM1: C = 100pF charged to V_{HBM1} with resistor R = 1.5kΩ in series based on MIL 883, Method 3015.7. ESD protection referenced to the Human Body Model is tested with devices in ceramic dual in-line packages (CDIP) during product qualification.

3. Recommended Operating Conditions

Note: The reference for all voltages is Vss.

Table 3.1 Recommended Operating Conditions

PARAMETER	SYMBOL	MIN	TYP	MAX	UNIT
Supply Voltage	V _{DD}	1.68	–	3.6	V
VDD Rise Time	t _{VDD}			200	μs
Bridge Current [a]	I _{VDDB}			1.8	mA
				16.5	
Operation Temperature Range	T _{AMB}	-40	–	85	°C
External (Parasitic) Capacitance between VDDDB and VSS	C _L	0.01		50	nF

[a] Power supply rejection is reduced if a current in the range of 16.5mA > I_{VDDB} > 1.8mA is drawn out of VDDDB.

A dynamic power-on-reset circuit is implemented in order to achieve minimum current consumption in Sleep Mode. The VDD low level and the subsequent rise time and VDD rising slope must meet the requirements in Table 3.2 to guarantee an overall IC reset; lower VDD low levels allow slower rising of the subsequent on-ramp of VDD. Other combinations might also be possible. For example, the reset trigger can be influenced by increasing the power-down time and lowering the VDD rising slope requirement. Alternatively, the RES pin can be connected and used to control safe resetting of the ZSSC3224. RES is active-low; a VDD-VSS-VDD transition at the RES pin leads to a complete ZSSC3224 reset.

Table 3.2 Requirements for VDD Power-on Reset

PARAMETER	SYMBOL	MIN	TYP	MAX	UNIT
Power-Down Time (duration of VDD Low Level)	t _{SPIKE}	3	–	–	μs
VDD Low Level	V _{DDlow}	0	–	0.2	V
VDD Rising Slope	SR _{VDD}	10	–	–	V/ms

4. Electrical Characteristics

All parameter values are valid only under the specified operating conditions. All voltages are referenced to V_{SS}.

Table 4.1 Electrical Characteristics

Note: See important table notes at the end of the table.

Parameter	Symbol	Conditions/Comments	Min	Typ	Max	Unit
Supply						
External Sensor Supply Voltage, ADC Reference Voltage	V _{DDB}	Internally generated	1.60	1.68	1.75	V
Current Consumption	I _{VDD}	Active State, average		1050	1500	μA
		Sleep Mode, idle current, ≤ 85°C		20	250	nA
Power Supply Rejection 20·log ₁₀ (V _{DD} /V _{DDB}) (see section 4.1)	PSR _{VDD}	V _{DD} = 1.8V	17	60	88	dB
		V _{DD} = 2V	32	65	91	dB
Analog-to-Digital Converter (ADC, A2D)						
Resolution	r _{ADC}		12		24	Bit
ADC Clock Frequency	f _{ADC}	Internal ADC clock	0.9	1	1.1	MHz
Conversion Rate	f _{S,raw}	Conversions per second for single 24-bit external sensor A2D conversion (without auto-zero measurement AZ)			144	Hz
		Conversions per second for single 16-bit temperature sensor A2D conversion (without AZ)			2.3	kHz
Amplifier						
Gain	G _{amp}	64 steps	6.6		216	
Gain Error	G _{err}	Referenced to nominal gain	-2.5	–	2.5	%
Sensor Signal Conditioning Performance						
ZSSC3224 Accuracy Error ^[a]	Err _{A,IC}	Accuracy error for sensor that is ideally linear (in temperature and measurand)			0.01	%FSO
Conversion Rate	f _{s,SSC}	Conversion per second for fully corrected 24-bit measurement		58	60	Hz
Input						
Input Voltage Range	V _{INP} , V _{INN}	Input voltage range at INP and INN pins	0.65		1.05	V
External Sensor Bridge Resistance	R _{BR}	Full power supply disturbance rejection (PSRR) capabilities	1	10	50	kΩ
		Reduced PSRR, but full functionality	100		999	Ω

Parameter	Symbol	Conditions/Comments	Min	Typ	Max	Unit
Power-Up						
Start-up Time	t _{STA1}	V _{DD} ramp up to interface communication (see section 6.1)			1	ms
	t _{STA2}	V _{DD} ramp up to analog operation			2.5	ms
Wake-up Time	t _{WUP1}	Sleep to Active State interface communication			0.5	ms
	t _{WUP2}	Sleep to Active State analog operation			2	ms
Oscillator						
Internal Oscillator Frequency	f _{CLK}		3.6	4	4.4	MHz
Internal Temperature Sensor						
Temperature Resolution		-40°C to +85°C		0.7		mK/LSB
Interface and Memory						
SPI Clock Frequency	f _{C,SPI}	Maximum capacitance at MISO line: 40pF at V _{DD} =1.8V		1	20	MHz
I2C Clock Frequency	f _{C,I2C}				3.4	MHz
Program Time	t _{prog}	MTP programming time per 16-bit register		5	16	ms
Endurance	n _{MTP}	Number of reprogramming cycles	1000	10000		Numeric
Data Retention	t _{RET_MTP}	1000h at 125°C	10			Years

[a] Percentage referred to maximum full-scale output (FSO); e.g. for 24-bit measurements:
 $Err_{A,IC} [\%FSO] = 100 \cdot \text{MAX}\{ |ADC_{meas} - ADC_{ideal}| \} / 2^{24}$.

4.1 Power Supply Rejection Ratio (PSRR) versus Frequency

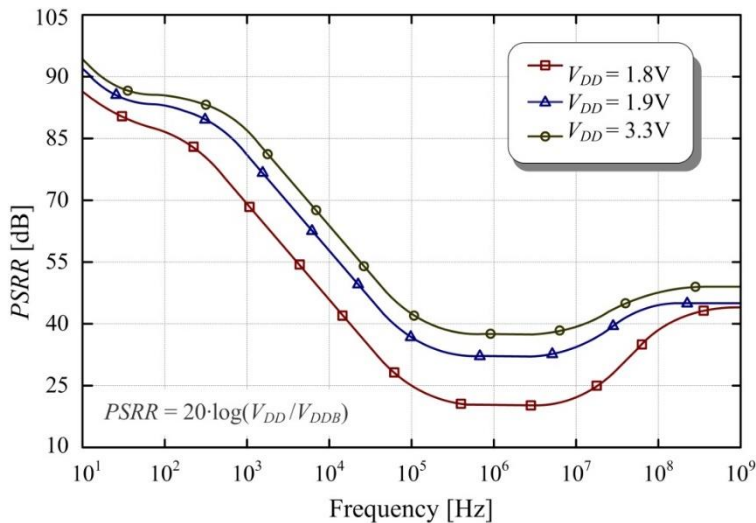

5. Circuit Description

5.1 Brief Description

The ZSSC3224 provides a highly accurate amplification of bridge sensor signals. The compensation of sensor offset, sensitivity, temperature drift, and non-linearity is accomplished via a 26-bit DSP core running a correction algorithm with calibration coefficients stored in a non-volatile memory. The ZSSC3224 can be configured for a wide range of resistive bridge sensor types and for absolute voltage source sensors. A digital interface (SPI or I2C) enables communication. The ZSSC3224 supports two operational modes: Normal Mode and Command Mode. Normal Mode is the standard operating mode. Typically in Normal Mode, the ZSSC3224 wakes up from Sleep Mode (low power), runs a measurement in Active State, and automatically returns to the Sleep Mode. (See section 6.4 for details on operational modes.)

5.2 Signal Flow and Block Diagram

See Figure 5.1 and Figure 5.2 for the ZSSC3224 block diagram for different input sensors. The sensor bridge supply V_{DDB} and the power supply for analog circuitry are provided by a voltage regulator, which is optimized for power supply disturbance rejection (PSRR). See section 4.1 for a graph of PSRR versus frequency. To improve noise suppression, the digital blocks are powered by a separate voltage regulator. A power supervision circuit monitors all supply voltages and generates appropriate reset signals for initializing the digital blocks.

The System Control Unit controls the analog circuitry to perform the three measurement types: external sensor, temperature, and offset measurement. The multiplexer selects the signal input to the amplifier, which can be the external signals from the input pins INP and INN or the internal temperature reference sensor signals. A full measurement request will trigger an automatic sequence of all measurement types and all input signals.

Figure 5.1 ZSSC3224 Functional Block Diagram with Resistive-Bridge Sensor

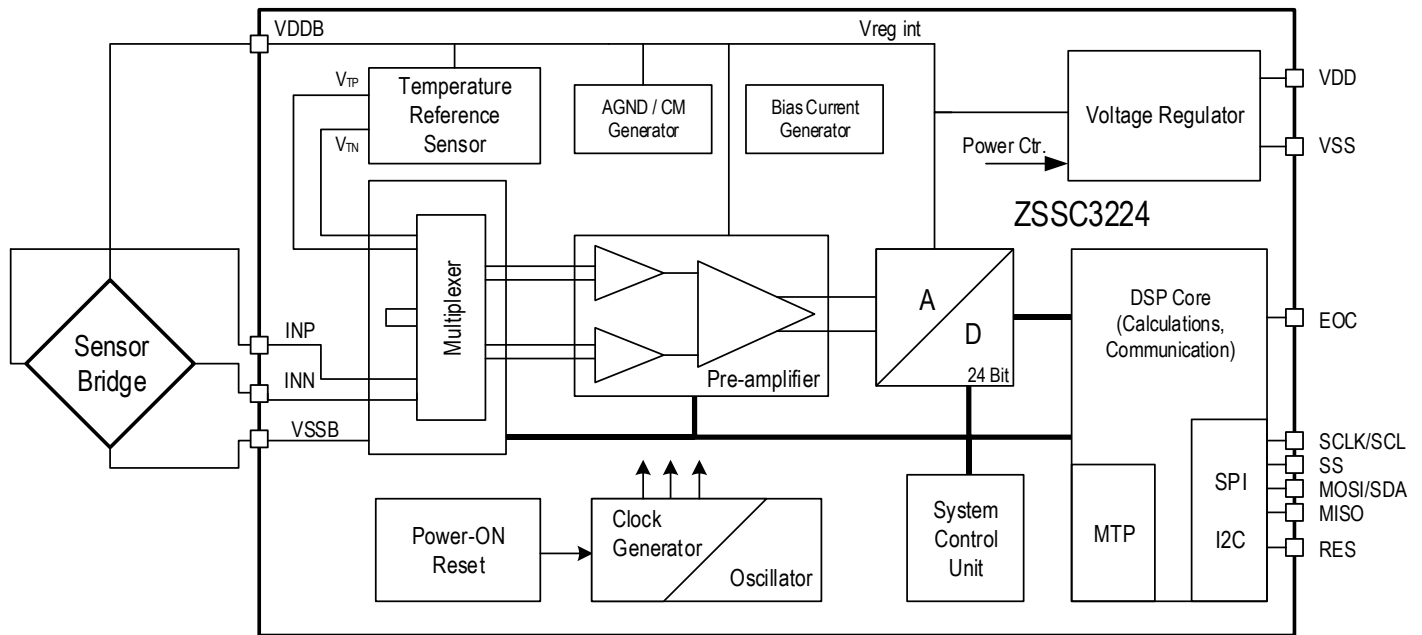
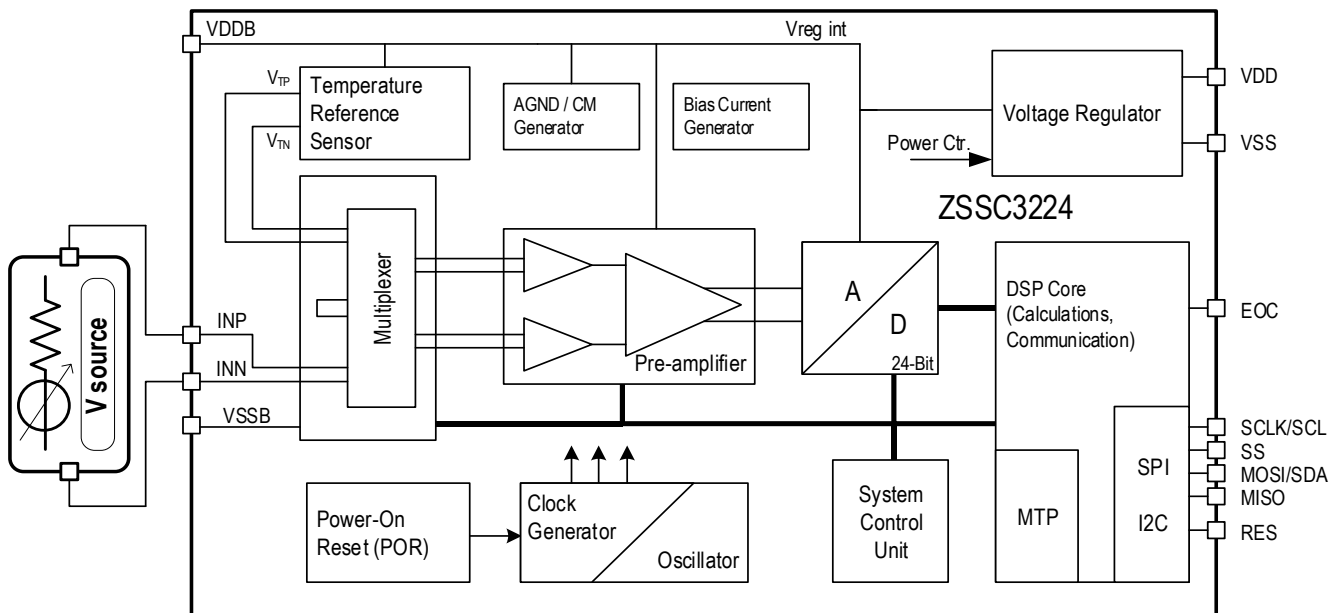

Figure 5.2 ZSSC3224 Functional Block Diagram with Voltage-Source Sensor



The amplifier consists of two stages with programmable gain values.

The ZSSC3224 employs a programmable analog-to-digital converter (ADC) optimized for conversion speed and noise suppression. The programmable resolution from 12 to 24 bits provides flexibility for adapting the conversion characteristics. To improve power supply noise suppression, the ADC uses the bridge supply V_{DDB} as its reference voltage leading to a ratiometric measurement topology if the external sensor is a bridge-type element.

The remaining ZSSC3224-internal offset and the sensor element offset, i.e., the overall system offset for the amplifier and ADC, can be canceled by means of an offset and auto-zero measurement, respectively.

The DSP accomplishes the auto-zero, span, and 1st and 2nd order temperature compensation of the measured external sensor signal. The correction coefficients are stored in the MTP memory.

The ZSSC3224 supports SPI and I2C interface communication for controlling the ZSSC3224, configuration, and measurement result output.

5.3 Analog Front End

5.3.1 Amplifier

The amplifier has a fully differential architecture and consists of two stages. The amplification of each stage and the external sensor gain polarity are programmable via settings in the Measurement Configuration Register *SM_config1* and *SM_config2* (addresses 12_{HEX} and 16_{HEX}; see section 6.6.2) in the MTP memory (for details, see section 5.4.2).

Note: Only one of these two possible configurations is used for the measurement. The default configuration is *SM_config1*. Alternately, *SM_config2* can be implemented by sending a command to select this configuration for the measurement (see section 6.5.1). The term *SM_config* is used in explanations for general register content and functionality for both *SM_config1* and *SM_config2*, as the registers' bit assignments are exactly the same for both registers.

The first 6 bits of *SM_config* are the programmable gain settings *Gain_stage1* and *Gain_stage2*. The options for the programmable gain settings are listed in Table 5.1 and Table 5.2.

Table 5.1 Amplifier Gain: Stage 1

Gain_stage1			
SM_config Bit 2	SM_config Bit 1	SM_config Bit 0	Gain _{amp1}
0	0	0	6
0	0	1	12
0	1	0	20
0	1	1	30
1	0	0	40
1	0	1	60
1	1	0	80
1	1	1	120

Table 5.2 Amplifier Gain: Stage 2

Gain_stage2			
SM_config Bit 5	SM_config Bit 4	SM_config Bit 3	Gain _{amp2}
0	0	0	1.1
0	0	1	1.2
0	1	0	1.3
0	1	1	1.4
1	0	0	1.5
1	0	1	1.6
1	1	0	1.7
1	1	1	1.8

If needed, the polarity of the sensor bridge gain can be reversed by setting the *Gain_polarity* bit, which is bit 6 in the *SM_config* register (see section 6.6.2). Changing the gain polarity is achieved by inverting the chopper clock. Table 5.3 gives the settings for the *Gain_polarity* bit. This feature enables applying a sensor to the ZSSC3224 with swapped input signals at INN and INP; e.g., to avoid crossing wires for the final sensor module's assembly.

Table 5.3 Gain Polarity

Gain_polarity (SM_config Bit 6)	Gain	Setting Description
0	+1	No polarity change.
1	-1	Gain polarity is inverted.

5.3.2 Analog-to-Digital Converter

An analog-to-digital converter (ADC) is used to digitize the amplifier signal. To allow optimizing the trade-off between conversion time and resolution, the resolution can be programmed in a range from 12-bit to 24-bit (*Adc_bits* bit field in the *SM_config* register; section 6.6.2). The ADC processes differential input signals.

Table 5.4 ADC Conversion Times for a Single Analog-to-Digital Conversion

Resolution (Bits)	Conversion Time in μs (typical)
12	140
13	185
14	250
15	335
16	470
17	640
18	890
19	1250
20	1760
21	2460
22	3480
23	4890
24	6940

The ADC can perform an offset shift in order to adapt input signals with offsets to the ADC input range. The shift feature is enabled by setting the *SM_config* register's bit 15 = 1 (*Shift_method* = 1). The respective analog offset shift can be set up with bits [14:12], the *Offset* bit field in *SM_config*. The offset shift causes the ADC to perform an additional amplification of the ADC's input signal by a factor of 2. This must be taken into consideration for a correct analog sensor setup via configuration of the pre-amplifier's gain, the ADC offset shift, and the potential ADC gain.

The overall analog amplification $Gain_{total} = Gain_{amp1} * Gain_{amp2} * Gain_{ADC}$ can be determined for the following options:

If no offset shift is selected, i.e., *Shift_method* = 0 and *Offset* = 000 in *SM_config*,

$$Gain_{total} = Gain_{amp1} * Gain_{amp2} * 1$$

If ADC offset shift is selected, i.e., *Shift_method* = 1 and *Offset* \neq 000 in *SM_config*,

$$Gain_{total} = Gain_{amp1} * Gain_{amp2} * 2$$

Table 5.5 ADC Offset Shift

SM_config Bit 15 (Shift_method)	Offset Shift in ADC				ADC Offset Shift of Input Signal as a Percent of Full Scale
	Offset: SM_config Bit 14	Offset: SM_config Bit 13	Offset: SM_config Bit 12	Gain _{ADC}	
0	0	0	0	1	0%
1	0	0	0	2	0%
1	0	0	1	2	6.75%
1	0	1	0	2	12.50%
1	0	1	1	2	19.25%
1	1	0	0	2	25.00%
1	1	0	1	2	31.75%
1	1	1	0	2	38.50%
1	1	1	1	2	43.25%

Important note: If the required configuration is no offset shift and no additional gain factor (and therefore $Gain_{ADC} = 1$), then the only valid settings are *Shift_method* = 0 and *Offset* = 000 in *SM_config*. Any other setup using *Shift_method* = 0 combined with *Offset* ≠ 000 leads to erroneous analog setups.

The setting for ADC resolution for the external sensor (bridge or voltage-source sensor) affects the typical measurement duration and noise performance as shown in Table 5.6 for the example of a bridge sensor measurement using the “Measure” command (AA_{HEX}; see section 6.4.1). See section 6.2 for definitions of measurement types AZSM, SM, AZTM, and TM.

Table 5.6 Typical Conversion Times versus Noise Performance with Full Sensor Signal Conditioning for Measurement including AZSM, SM, AZTM, and TM (Bridge-Type Sensor)

Note: See important notes at the end of the table.

ADC Resolution: Internal Temperature Sensor	Typical ADC Resolution: External Sensor Setting	Typical Measurement Duration ^[a] , MEASURE, (AA _{HEX}) (ms)	Typical 3-Sigma Noise for SSC- Corrected Output ^[b] (counts)
18	16	4.1	4.9
18	17	4.4	8.3
18	18	4.9	16.1
18	19	5.6	33.5
18	20	6.6	65.0
18	21	8.1	118.1
18	22	10.1	233.9

ADC Resolution: Internal Temperature Sensor	Typical ADC Resolution: External Sensor Setting	Typical Measurement Duration ^[a] , MEASURE, (AA _{HEX}) (ms)	Typical 3-Sigma Noise for SSC-Corrected Output ^[b] (counts)
18	23	12.9	466.3
18	24	17.0	922.0

[a] Measurement duration is defined as the time from the high/low transition at the EOC pin at the beginning of the measurement until the next low/high transition of the EOC signal at the end of a single measurement in Sleep Mode.

[b] Reference noise values normalized to the external sensor's ADC resolution, obtained with the following setup: 40kΩ sensor bridge, 25°C operating temperature, Gain=52, ADC Offset=25%, VDD=1.79V.

5.3.3 Selection of Gain and Offset – Sensor System Dimensioning

The optimal gain (and offset) setup for a specific sensor element can be determined by the following steps:

1. Collect sensor element's characteristic, statistical data (over temperature, ambient sensor parameter, and over production tolerances):
 - a. Minimum differential output voltage: V_{min}
 - b. Maximum differential output voltage: V_{max}

Note: The best possible setup can only be determined if the absolute value of V_{max} is larger than the absolute value of V_{min} . If this is not the case, the gain polarity should be reversed by means of the *Gain_polarity* bit in the MTP's *SM_config* register.

2. Calculate:
 - a. Common mode level; i.e., differential offset of the sensor output: $V_{CM} = 0.5 * (V_{max} + V_{min})$
 - b. Relative or percentage offset of the sensor output: $Offset_{sensor}[\%] = \frac{V_{CM}}{V_{max} - V_{min}} * 100\%$
3. Determine which of the two following cases is valid:
 - a. If $Offset_{sensor}[\%] > 43\%$ then select $Offset = 111$ (i.e., 43.25%)
 - b. If $0\% < Offset_{sensor}[\%] \leq 43\%$ then select $Offset \leq Offset_{sensor}[\%]$ (see Table 5.5 for possible ADC *Offset* setup values)
4. The totally required, optimum gain can be determined as

$$Gain_{total, opt} = \frac{1.4V}{V_{max} * \left(1 - \frac{Offset_{sensor}}{100}\right)}$$

Configure gain factors in the following step such that $Gain_{total} \leq Gain_{total, opt}$ (see section 5.3.1).

5. The gain setup can be separated into the three factors $Gain_{amp1}$, $Gain_{amp2}$ (for the 2-stage amplifier), and $Gain_{ADC}$ (1 for no shift or 2 for shift operation) according to

$$Gain_{total} = Gain_{amp1} * Gain_{amp2} * Gain_{ADC}$$

- a. If no offset shift is performed ($Shift_method = 0$ and $Offset = 000$), the amplifier gain is $Gain_{total}$
- b. If an offset shift is performed ($Shift_method = 1$), the amplifier gain is $0.5 * Gain_{total}$

Figure 5.3 ADC Gain and Offset Setup

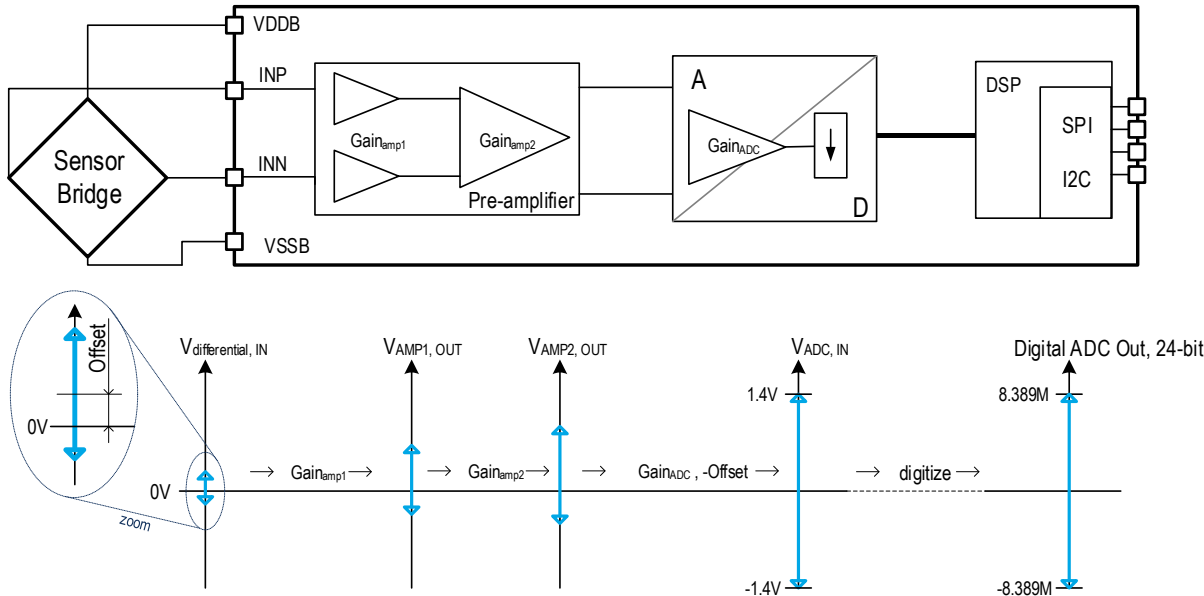

5.3.4 Temperature Measurement

The ZSSC3224 provides an internal temperature sensor measurement to allow compensation for temperature effects. See section 4 for the temperature sensor resolution. The temperature output signal is a differential voltage that is adapted by the amplifier for the ADC input.

For temperature measurements, the respective settings are defined and programmed in the MTP by IDT.

5.3.5 External Sensor Supply: Bridge Sensors

The ZSSC3224 provides dedicated supply pins VDDB and VSSB for resistive bridge-type sensors (*AbsV_enable* bit 11 = 0 in *SM_config*, MTP registers 12_{HEX} or 16_{HEX}). The ADC reference voltages for the sensor bridge measurement are derived from these internal voltages such that bridge supply disturbances are suppressed. The current drive ability of V_{DDB} is limited (see I_{VDDB} in section 3).

5.3.6 External Sensor: Absolute Voltage Source Sensors

Alternatively, the ZSSC3224 can process signals from an absolute-voltage source sensor; e.g., a thermopile element. The respective input-type selection can be done with the *AbsV_enable* bit 11 = 1 in *SM_config*, MTP registers 12_{HEX} or 16_{HEX}. The respective sensor element must be connected between the INP and INN pins; INN is internally connected to the ZSSC3224’s analog ground (important: this is not VSSB). Do not connect VDDB and VSSB if an absolute-voltage source sensor is applied. The offset shift should be set to maximum in this case, *Shift_method* = 1 and *Offset* = 111 in *SM_config*. The required gain can be determined according to the procedure described in section 5.3.3.

5.4 Digital Section

5.4.1 Digital Signal Processor (DSP) Core

The “DSP Core” block performs the algorithm for correcting the sensor signal. The required coefficients are stored in the MTP memory.

When the measurement results are available, the “end of conversion” signal is set at the EOC pin if no interrupt-threshold has been set up (bits[8:7] = 00 in memory register 02_{HEX}). The internal EOC information is valid only if both the measurement and calculation have been completed. Alternatively, the EOC pin can indicate exceeding or underrunning of a certain threshold or leaving a valid-result range as described in section 6.3.

5.4.2 MTP Memory

The ZSSC3224’s memory is designed with a true multiple time programmable (MTP) structure. The memory is organized in 16-bit registers that can be re-written multiple times (at least 1000). The user has access to a 57×16 -bit storage area for values such as calibration coefficients. The required programming voltage is generated internally in the ZSSC3224. A checksum of the entire memory is evaluated for integrity-check purposes. The checksum can be generated with the command 90_{HEX} (see section 6.4.1).

5.4.3 Clock Generator

The clock generator provides approximately 4MHz and 1MHz clock signals as the time base for ZSSC3224-internal signal processing. The frequency is trimmed during production test.

5.4.4 Power Supervision

The power supervision block, which is a part of the voltage regulator combined with the digital section, monitors all power supplies to ensure a defined reset of all digital blocks during power-up or power supply interruptions. “Brown-out” cases at the supply that do not meet the power-on reset (POR) requirements (see Table 3.2), must be resolved with a reset pulse at the RES pin.

5.4.5 Interface

The ZSSC3224 can communicate with the user’s communication master or computer via an SPI or I2C interface. The interface type is selectable with the first activity at the interface after power-up or reset:

- If the first command is an I2C command and the SS pin has been inactive until receiving this command, the ZSSC3224 enters I2C Mode.
- If the first interface action is the SS pin being set to active (HIGH-active or LOW-active depending on the *SS_polarity* bit[9] in memory interface register 02_{HEX}), then the ZSSC3224 enters SPI Mode.

During the initiation sequence (after power-up or reset), any potential transition on SS is ignored. Switching to the SPI Mode is only possible after the power-up sequence. If SS is not connected, the SS pin internal pull-up keeps the ZSSC3224 in I2C Mode.

To also provide interface accessibility in Sleep Mode (all features inactive except for the digital interface logic), the interface circuitry is directly supplied by VDD.

6. Functional Description

6.1 Power Up

Specifications for this section are given in sections 3 and 4. On power-up, the ZSSC3224 communication interface is able to receive the first command after a time t_{STA1} from when the VDD supply is within operating specifications. The ZSSC3224 can begin the first measurement after a time of t_{STA2} from when the VDD supply is operational. Alternatively, instead of a power-on reset, a reset and new power-up sequence can be triggered by an IC-reset signal (high low) at the RES pin.

The wake up time from Sleep Mode to Active State (see section 6.4) after receiving the activating command is defined as t_{WUP1} and t_{WUP2} . In Command Mode, subsequent commands can be sent after t_{WUP1} . The first measurement starts after t_{WUP2} if a measurement request was sent.

6.2 Measurements

Available measurement procedures are

- AZSM: auto-zero (external) sensor measurement
- SM: (external) sensor measurement
- AZTM: auto-zero temperature measurement
- TM: temperature measurement

AZSM: The configuration is loaded for measuring the external sensor; i.e., a resistive bridge or an absolute voltage source. The “Multiplexer” block connects the amplifier input to the AGND analog ground reference. An analog-to-digital (A2D) conversion is performed so that the inherent system offset for the configuration is converted by the ADC to a digital word with a resolution according to the respective MTP configuration.

SM: The configuration is loaded for measuring the external sensor; i.e., a resistive bridge or an absolute voltage source. The “Multiplexer” block connects the amplifier input to the INP and INN pins. An A2D conversion is performed. The result is a digital word with a resolution according to the MTP configuration.

AZTM: The configuration for temperature measurements is loaded. The “Multiplexer” block connects the amplifier input to AGND. An analog-to-digital conversion is performed so that the inherent system offset for the temperature configuration is converted by the ADC with a resolution according to the respective MTP configuration.

TM: The configuration for temperature measurements is loaded. The “Multiplexer” block connects the amplifier input to the internal temperature sensor. An A2D conversion is performed. The result is a digital word with a resolution according to the MTP configuration.

The typical application’s measurement cycle is a complete SSC measurement (using one of the commands AA_{HEX} to AF_{HEX}; see section 6.4.1) with AZSM, SM, AZTM, and TM followed by a signal correction calculation.

6.3 Interrupt (EOC Pin)

The EOC pin can be programmed to operate either as a pure “measurement busy” and end-of-conversion (EOC) indicator or as a configurable interrupt indicator. The basic operation must be programmed to the *INT_setup* bits [8:7] in register 02_{HEX} (see Table 6.5). One or two 24-bit-quantized thresholds can be programmed (TRSH1 and TRSH2 in memory registers 13_{HEX}, 14_{HEX}, and 15_{HEX}).

The thresholds are programmed left-aligned in the memory; i.e., they must be programmed with the threshold’s MSB in the memory register’s MSB, etc. The number of LSB threshold bits that are used is equal to the number of bits for the selected ADC resolution (determined by the *Adc_bits* field in registers 12_{HEX} and 16_{HEX}); unused LSB bits are ignored.

The interrupt functionality is only available for digital values from the SSC-calculation unit (i.e., after sensor signal conditioning); raw values cannot be monitored by the interrupt feature. Figure 6.1 shows the different setup options and the respective response at the EOC pin. The use of the interrupt functionality is recommended for cyclic operation (command AB_{HEX} with the respective power-down setup in the *Interface Configuration* memory register 02_{HEX}). The EOC level continuously represents the respective SSC-measurement results only during cyclic operation. For single or oversample measurement requests without cyclic operation, the EOC output signal is reset to logical zero at the beginning of each new measurement, even though the interrupt thresholds are established correctly at the end of each measurement (setting EOC to logical one or zero is dependent on the interrupt setup).

Figure 6.1 Interrupt Functionality

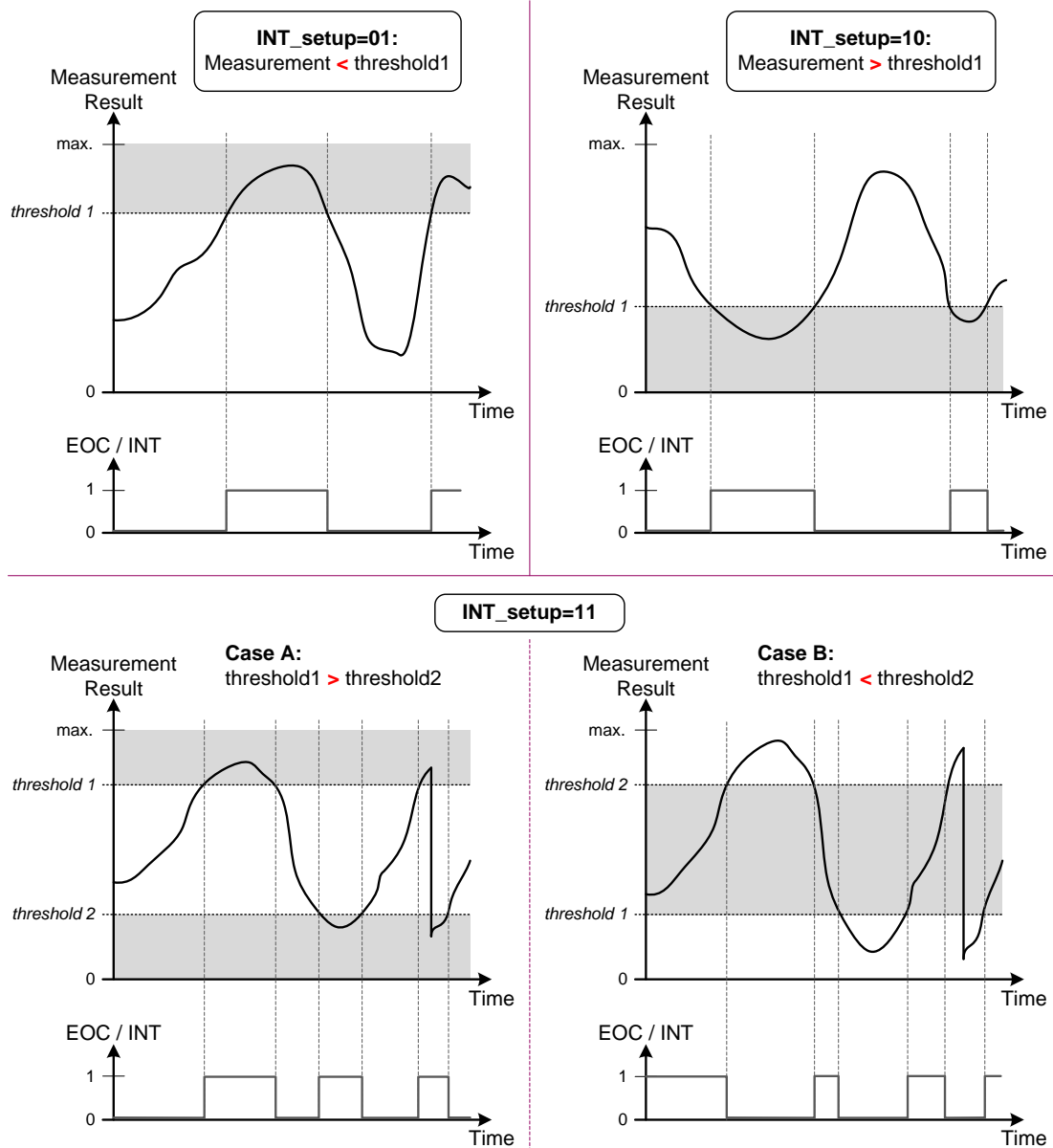

6.4 Operational Modes

Figure 6.2 illustrates the ZSSC3224 power-up sequence and subsequent operation depending on the selected interface communication mode (I2C or SPI) as determined by interface-related first activities after power-up or reset. If the first command after power-up is a valid I2C command, the interface will function as an I2C interface until the next power-on reset (POR). If there is no valid I2C command, but an active signal at the SS pin is detected as the first valid activity, then the interface will respond as an SPI slave. With either interface, after the voltage regulators are switched on, the ZSSC3224's low-voltage section (LV) is active while the related interface configuration information is read from memory. Then the LV section is switched off, the ZSSC3224 goes into Sleep Mode, and the interface is ready to receive commands. The interface is always powered by V_{DD} , so it is referred to as the high voltage section (HV).

See Table 6.1 for definitions of the commands.

Figure 6.3 shows the ZSSC3224 operation in Normal Mode (with two operation principles: "Sleep" and "Cyclic") and Command Mode, including when the LV and HV sections are active as indicated by the color legend. The Normal Mode automatically returns to Sleep Mode after executing the requested measurements, or periodically wakes up and conducts another measurement according to the setting for the sleep duration configured by *CYC_period* (bits[14:12] in memory register 02_{HEX}). In Command Mode, the ZSSC3224 remains active if a dedicated command (e.g., Start_NOM) is sent, which is helpful during calibration. Command Mode can only be entered if Start_CM (command A9_{HEX}; see Table 6.1) is the first command received after a POR.

Figure 6.2 Operational Flow Chart: Power Up

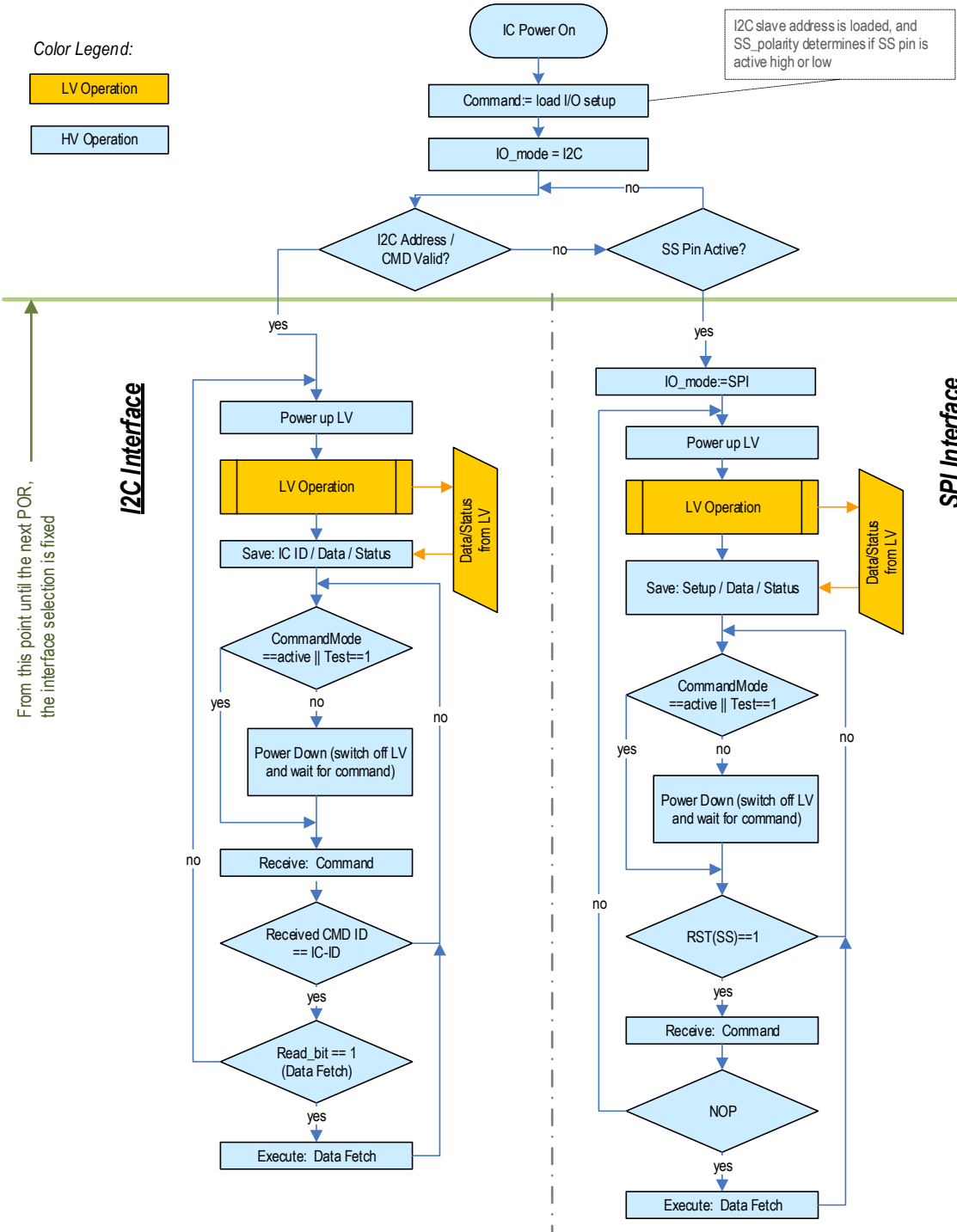
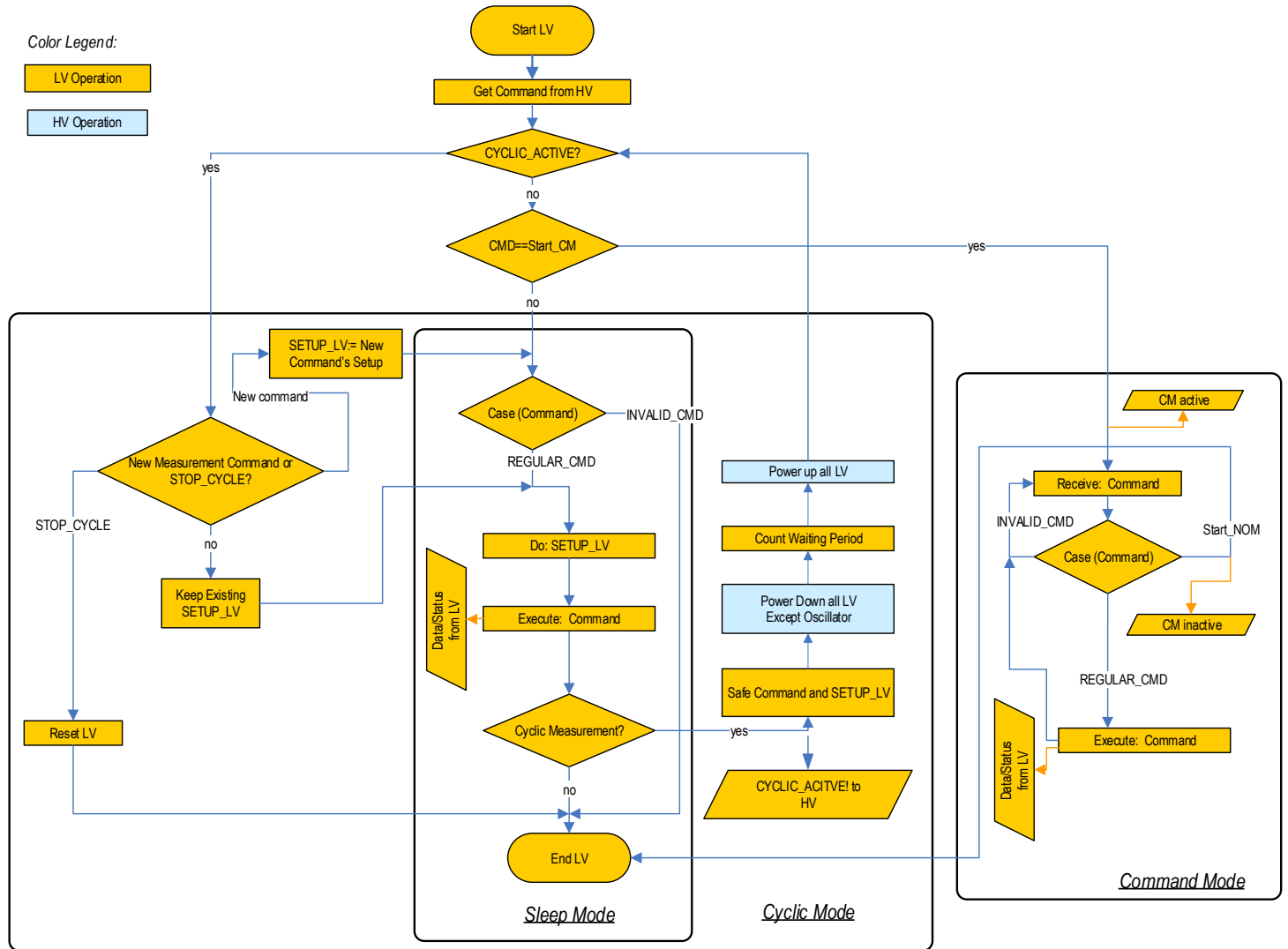

Figure 6.3 Operational Flow Chart: Command Mode and Normal Mode (Sleep and Cyclic)



6.4.1 SPI/I2C Commands

The SPI/I2C commands supported by the ZSSC3224 are listed in Table 6.1. The command to read an address in the user memory is the same as its address. The command to write to an address in user memory is the address plus 40_{HEX}.

There is an IDT-reserved section of memory that can be read but not over-written by the user.

Table 6.1 SPI/I2C Commands

Note: Every return starts with a status byte followed by the data word as described in section 6.5.1.

Note: See important table notes at the end of the table.

Command (Byte)	Return	Description	Normal Mode	Command Mode
00 _{HEX} to 39 _{HEX}	16-bit user data	Read data in the user memory address (00 _{HEX} to 39 _{HEX}) matching the command (might not be using all addresses).	Yes	Yes
3A _{HEX} to 3F _{HEX}	16-bit IDT-reserved memory data	Read data in IDT-reserved memory at address (3A _{HEX} to 3F _{HEX}).	Yes	Yes
40 _{HEX} to 79 _{HEX} followed by data (0000 _{HEX} to FFFF _{HEX})	–	Write data to user memory at address specified by command minus 40 _{HEX} (addresses 00 _{HEX} to 39 _{HEX} respectively; might not be using all addresses).	Yes	Yes
90 _{HEX}	–	Calculate and write memory checksum (CRC), which is register address 39 _{HEX} .	Yes	Yes
A0 _{HEX} to A7 _{HEX} followed by XXXX _{HEX} (see Table 6.2)	24-bit formatted raw data	Get_Raw This command can be used to perform a measurement and write the raw ADC data into the output register. The LSB of the command determines how the AFE configuration register is loaded for the Get_Raw measurement (see Table 6.2).	Yes	Yes
A8 _{HEX}	–	Start_NOM Exit Command Mode and transition to Normal Mode (Sleep or Cyclic).	No	Yes
A9 _{HEX}	–	Start_CM Exit Normal Mode and transition to Command Mode (as very first command after power-up).	Yes	No
AA _{HEX}	24-bit formatted fully corrected sensor measurement data + 24-bit corrected temperature data ^[a]	Measure Trigger full measurement cycle (AZSM, SM, AZTM, and TM, as described in section 6.2) and calculation and storage of data in the output buffer using the configuration from MTP.	Yes	Yes
AB _{HEX}	24-bit formatted fully corrected sensor measurement data + 24-bit corrected temperature data ^[a]	Measure Cyclic This command triggers a continuous full measurement cycle (AZSM, SM, AZTM, and TM; see section 6.2) and calculation and storage of data in the output buffer using the configuration from MTP followed by a pause determined by <i>CYC_period</i> (bits[14:12] in memory register 02 _{HEX}).	Yes	Yes
AC _{HEX}	24-bit formatted fully corrected sensor measurement data + 24-bit corrected temperature data ^[a]	Oversample-2 Measure Mean value generation: 2 full measurements are conducted (as in command AA _{HEX}), the measurements' mean value is calculated, and data is stored in the output buffer using the configuration from MTP; no power down or pause between the 2 measurements.	Yes	Yes

Command (Byte)	Return	Description	Normal Mode	Command Mode
AD _{HEX}	24-bit formatted fully corrected sensor measurement data + 24-bit corrected temperature data ^[a]	Oversample-4 Measure Mean value generation: 4 full measurements (as in command AA _{HEX}) are conducted, the measurements' mean value is calculated, and data is stored in the output buffer using the configuration from MTP; no power down or pause between the 4 measurements.	Yes	Yes
AE _{HEX}	24-bit formatted fully corrected sensor measurement data + 24-bit corrected temperature data ^[a]	Oversample-8 Measure Mean value generation: 8 full measurements (as in command AA _{HEX}) are conducted, the measurements' mean value is calculated, and data is stored in the output buffer using the configuration from MTP; no power down or pause between the 8 measurements.	Yes	Yes
AF _{HEX}	24-bit formatted fully corrected sensor measurement data + 24-bit corrected temperature data ^[a]	Oversample-16 Measure Mean value generation: 16 full measurements (as in command AA _{HEX}) are conducted, the measurements' mean value is calculated, and data is stored in the output buffer using the configuration from MTP; no power down or pause between the 16 measurements.	Yes	Yes
B0 _{HEX}	—	Select SM_config1 register (12 _{HEX} in memory) For any measurement using the memory contents for the analog front-end and sensor setup, the respective setup is loaded from the SM_config1 register; status bit[1]=0 (default).	Yes	Yes
B1 _{HEX}	—	Select SM_config2 register (16 _{HEX} in memory) For any measurement using the memory contents for the analog front-end and sensor setup, the respective setup is loaded from the SM_config2 register; status bit[1]=1	Yes	Yes
BF _{HEX}	—	STOP_CYC This command causes a power-down halting the update / cyclic measurement operation and causing a transition from Normal to Sleep Mode.	Yes	Yes
FX _{HEX}	Status followed by last 24-bit data	NOP Only valid for SPI (see sections 6.5.1 and 6.5.2).	Yes	Yes

[a] Note: Any ADC measurement and SSC calculation output is formatted as a 24-bit data word, regardless of the effective ADC resolution used.

Table 6.2 Get_Raw Commands

Command	Measurement	AFE Configuration Register
A0 _{HEX} followed by 0000 _{HEX}	SM – Sensor Measurement	<i>SM_config</i> . See section 6.5.1.
A1 _{HEX} followed by ssss _{HEX}	SM – Sensor Measurement	sss is the user's configuration setting for the measurement provided via the interface. The format and purpose of the configuration bits must be according to the definitions for <i>SM_config</i> (see Table 6.5).
A2 _{HEX} followed by 0000 _{HEX}	SM-AZSM – Auto-Zero Corrected Sensor Measurement ^[a]	<i>SM_config</i> . See section 6.5.1.
A3 _{HEX} followed by ssss _{HEX}	SM-AZSM – Auto-Zero Corrected Sensor Measurement ^[b]	sss is the user's configuration setting for the measurement provided via the interface. The format and purpose of the configuration bits must be according to the definitions for <i>SM_config</i> .
A4 _{HEX} followed by 0000 _{HEX}	TM – Temperature Measurement	IDT-defined register.
A5 _{HEX} followed by ssss _{HEX}	TM – Temperature Measurement	sss is the user's configuration setting for the measurement provided via the interface. The format and purpose of configuration bits must be according to the definitions for <i>SM_config</i> and valid for temperature measurement in this case (bits [15:12] will be ignored).
A6 _{HEX} followed by 0000 _{HEX}	TM-AZTM – Auto-Zero Corrected Temperature Measurement ^[a]	IDT-defined register.
A7 _{HEX} followed by ssss _{HEX}	TM-AZTM – Auto-Zero Corrected Temperature Measurement ^[b]	sss is the user's configuration setting for the measurement provided via the interface. The format and purpose of these configuration bits must be according to the definitions for <i>SM_config</i> and valid for temperature measurement in this case (bits [15:12] will be ignored).

[a] Recommended for raw data collection during calibration coefficient determination using the measurement setups pre-programmed in MTP.

[b] Recommended for raw data collection during calibration coefficient determination using un-programmed (not in MTP), external measurement setups; e.g., for evaluation purposes.

6.5 Communication Interface

6.5.1 Common Functionality

Commands are handled by the command interpreter in the LV section. Commands that need additional data are not treated differently than other commands because the HV interface is able to buffer the command and all the data that belongs to the command and the command interpreter is activated as soon as a command byte is received.

Every response starts with a status byte followed by the data word. The data word depends on the previous command. It is possible to read the same data more than once if the read request is repeated (I2C) or a NOP command is sent (SPI). If the next command is not a read request (I2C) or a NOP (SPI), it invalidates any previous data.

The ZSSC3224 supports the parallel setup of two amplifier-ADC-configurations using *SM_config1* (default) and *SM_config2*. Switching between the two setups can be done with the commands B0_{HEX} (selects *SM_config1*) and B1_{HEX} (selects *SM_config2*). Note that the respective activation command must always be sent prior to the measurement request.

The status byte contains the following bits in the sequence shown in Table 6.3:

- Power indication (bit 6): 1 if the device is powered (V_{DDB} on); 0 if not powered. This is needed for the SPI Mode where the master reads all zeroes if the device is not powered or in power-on reset (POR).
- Busy indication (bit 5): 1 if the device is busy, which indicates that the data for the last command is not available yet. No new commands are processed if the device is busy.
Note: The device is always busy if the cyclic measurement operation has been set up and started.
- Currently active ZSSC3224 mode (bits [4:3]): 00 = Normal Mode; 01 = Command Mode; 1X = IDT reserved.
- Memory integrity/error flag (bit 2): 0 if integrity test passed; 1 if test failed. This bit indicates whether the checksum-based integrity check passed or failed. The memory error status bit is calculated only during the power-up sequence, so a newly written CRC will only be used for memory verification and status update after a subsequent ZSSC3224 power-on reset (POR) or reset via the RES pin.
- Config Setup (bit 1): This bit indicates which *SM_config* register is being used for the active configuration: *SM_config1* (12_{HEX}) or *SM_config2* (16_{HEX}). The two alternate configuration setups allow for two different configurations of the external sensor channel in order to support up to two application scenarios with the use of only one sensor-ZSSC3224 pair. This bit is 0 if *SM_config1* was selected (default). This bit is 1 if *SM_config2* was selected.
- ALU saturation (bit 0): If the last command was a measurement request, this bit is 0 if any intermediate value and the final SSC result are in a valid range and no SSC-calculation internal saturation occurred in the arithmetic logic unit (ALU). If the last command was a measurement request, this bit is 1 if an SSC-calculation internal saturation occurred. This bit is also 0 for any non-measurement command.

Table 6.3 General Status Byte

Bit	7	6	5	4	3	2	1	0
Meaning	0	Powered?	Busy?	Mode		Memory error?	Config Setup	ALU Saturation?

Table 6.4 Mode Status

Status[4:3]	Mode
00	Normal Mode (sleep and cyclic operations)
01	Command Mode
10	IDT reserved
11	IDT reserved

Further status information can be provided by the EOC pin. The EOC pin is set high when a measurement and calculation have been completed (if no interrupt threshold is used, i.e. *INT_setup*==00_{BIN}; see section 6.3).

6.5.2 SPI

The SPI Mode is available if the first interface activity after the ZSSC3224 power-up is an active signal at the SS pin. The polarity and phase of the SPI clock are programmable via the *CKP_CKE* setting in bits [11:10] in address 02_{HEX} as described in Table 6.5. *CKP_CKE* is two bits: CPHA (bit 10), which selects which edge of SCLK latches data, and CPOL (bit 11), which indicates whether SCLK is high or low when it is idle. The polarity of the SS signal and pin are programmable via the *SS_polarity* setting (bit 9). The different combinations of polarity and phase are illustrated in the figures below.

Figure 6.4 SPI Configuration CPHA=0

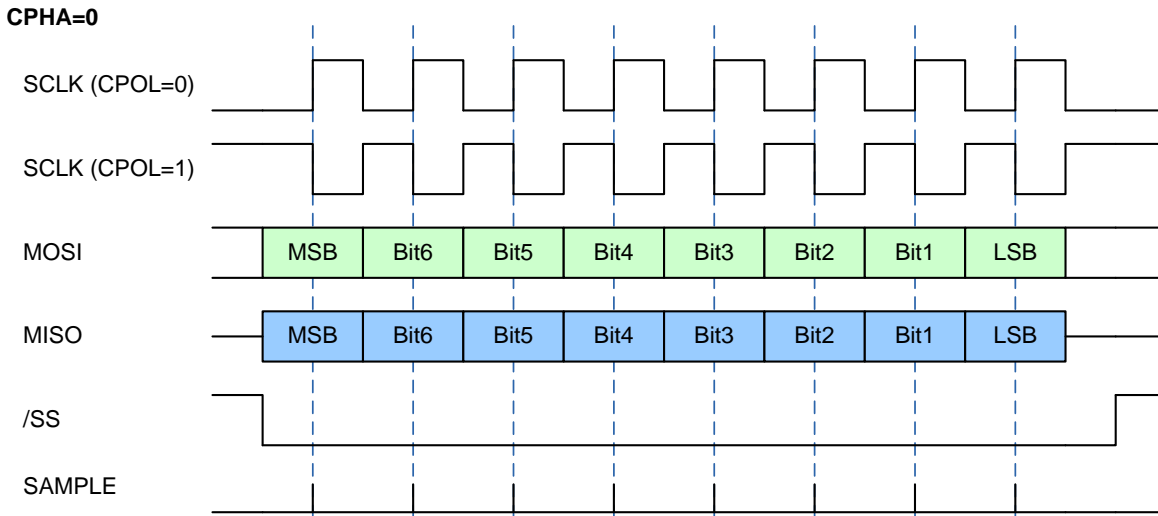
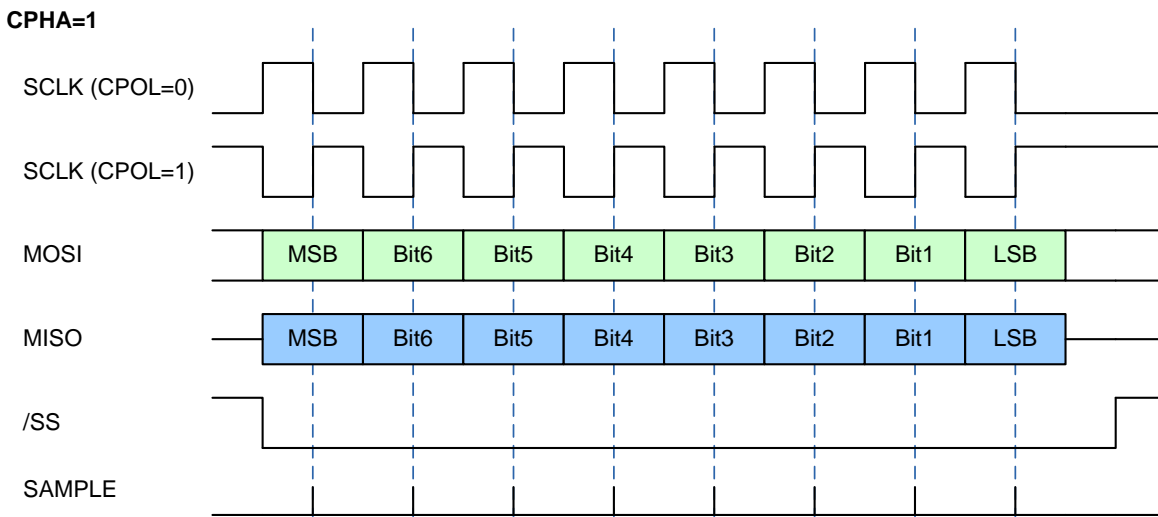

Figure 6.5 SPI Configuration CPHA=1



In SPI mode, each command except NOP is started as shown in Figure 6.6. After the execution of a command (busy = 0), the expected data can be read as illustrated in Figure 6.7 or if no data are returned by the command, the next command can be sent. The status can be read at any time with the NOP command (see Figure 6.8).

Figure 6.6 SPI Command Request

Command Request

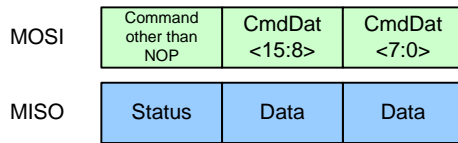

Note: A command request always consists of 3 bytes. If the command is shorter, then it must be completed with 0s. The data on MISO depend on the preceding command.

Figure 6.7 SPI Read Status

Read Status

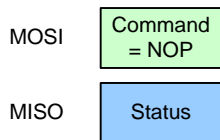
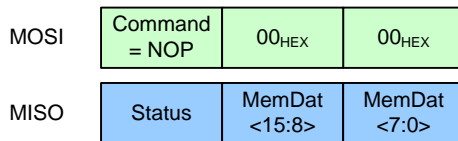

Figure 6.8 SPI Read Data

Read Data

(a) Example: after the completion of a Memory Read command



(b) Example: after the completion of a **Measure** command (AA_{HEX})

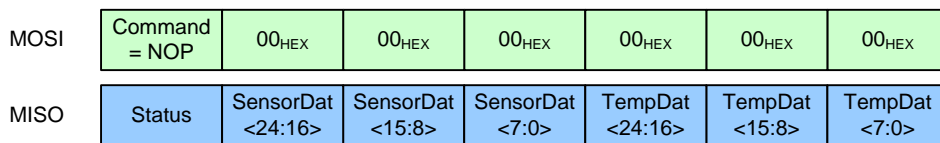

6.5.3 I2C

I2C Mode will be selected if the very first interface activity after ZSSC3224 power-up is an I2C command. In I2C Mode, each command is started as shown in Figure 6.9. Only the number of bytes that are needed for the command must be sent. An exception is the I2C High Speed Mode (see *Slave_Addr* in Table 6.5) for which 3 bytes must always be sent as in SPI Mode. After the execution of a command (busy = 0), the expected data can be read as illustrated in Figure 6.11 or if no data are returned by the command, the next command can be sent. The status can be read at any time as illustrated in Figure 6.10.

Figure 6.9 I2C Command Request

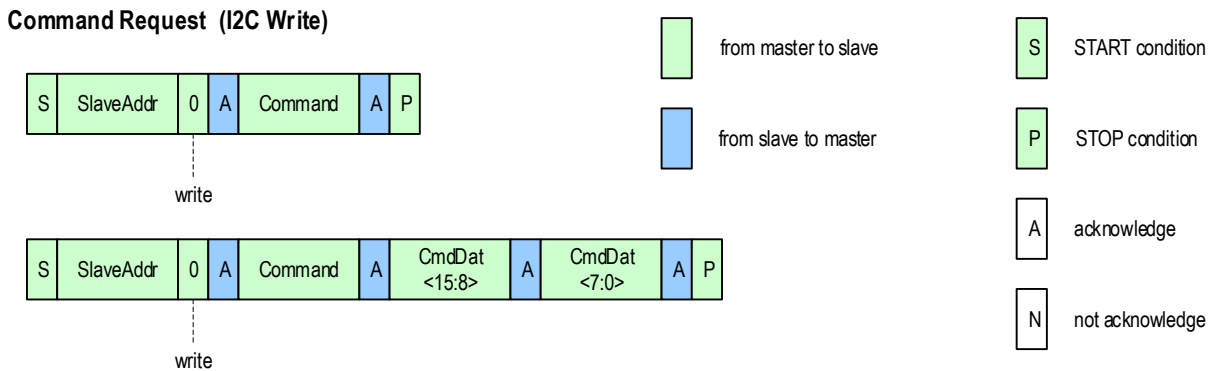

Figure 6.10 I2C Read Status

Read Status (I2C Read)

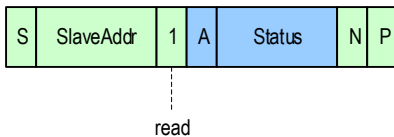
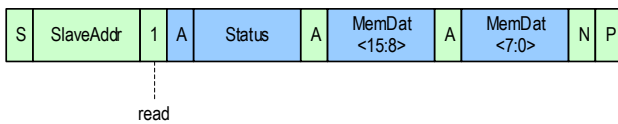

Figure 6.11 I2C Read Data

Read Data (I2C Read)

(a) Example: after the completion of a Memory Read command



(b) Example: after the completion of a Full Measurement command (AA_{HEX})

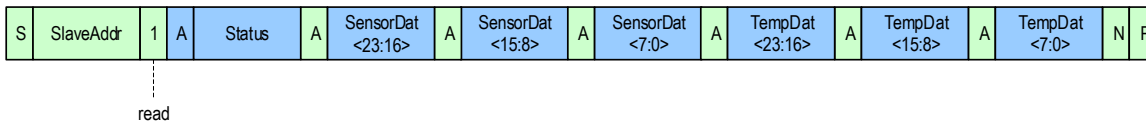

All mandatory I2C-bus protocol features are implemented. Optional protocol features such as clock stretching, 10-bit slave address, etc., are not supported by the ZSSC3224's interface.

In I2C-High-Speed Mode, a command consists of a fixed length of three bytes.

6.6 Multiple Time Programmable (MTP) Memory

In the ZSSC3224, the memory is organized in 16-bit registers and can be programmed multiple times (at least 1000). There are 57 x 16-bit registers available for customer use. Each register can be re-programmed. Basically, there are two MTP content sectors:

- Customer use: accessible by means of regular write operations: 40_{HEX} to 79_{HEX}. It contains the customer ID, interface setup data, measurement setup information, calibration coefficients, etc.
- IDT use: only accessible for write operations by IDT. The IDT sector contains specific trim information and is programmed during manufacturing test by IDT.

6.6.1 Programming Memory

Programming memory is possible with any specified supply voltage level at VDD. The MTP programming voltage itself is generated by means of an integrated charge pump, generating an internal memory programming voltage; no additional, external voltage, other than VDD (as specified) is needed. A single 16-bit register write will be completed within 16ms after the respective programming command has been sent. After the memory is programmed, it must be read again to verify the validity of the memory contents.

MTP Address	Word / Bit Range	Default Setting	Description	Notes / Explanations
Signal Conditioning Parameters				
03 _{HEX}	15:0	0000 _{HEX}	Offset_S[15:0]	Bits [15:0] of the 24-bit sensor offset correction coefficient <i>Offset_S</i> . (The MSBs of this coefficient including sign are <i>Offset_S</i> [23:16], which is bits [15:8] in 0D _{HEX} .)
04 _{HEX}	15:0	0000 _{HEX}	Gain_S[15:0]	Bits [15:0] of the 24-bit value of the sensor gain coefficient <i>Gain_S</i> . (The MSBs of this coefficient including sign are <i>Gain_S</i> [23:16], which is bits [7:0] in 0D _{HEX} .)
05 _{HEX}	15:0	0000 _{HEX}	Tcg[15:0]	Bits [15:0] of the 24-bit coefficient <i>Tcg</i> for the temperature correction of the sensor gain. (The MSBs of this coefficient including sign are <i>Tcg</i> [23:16], which is bits [15:8] in 0E _{HEX} .)
06 _{HEX}	15:0	0000 _{HEX}	Tco[15:0]	Bits [15:0] of the 24-bit coefficient <i>Tco</i> for temperature correction of the sensor offset. (The MSBs of this coefficient including sign are <i>Tco</i> [23:16], which is bits [7:0] in 0E _{HEX} .)
07 _{HEX}	15:0	0000 _{HEX}	SOT_tco[15:0]	Bits [15:0] of the 24-bit 2 nd order term <i>SOT_tco</i> applied to <i>Tco</i> . (The MSBs of this term including sign are <i>SOT_tco</i> [23:16], which is bits [15:8] in 0F _{HEX} .)
08 _{HEX}	15:0	0000 _{HEX}	SOT_tcg[15:0]	Bits [15:0] of the 24-bit 2 nd order term <i>SOT_tcg</i> applied to <i>Tcg</i> . (The MSBs of this term including sign are <i>SOT_tcg</i> [23:16], which is bits [7:0] in 0F _{HEX} .)
09 _{HEX}	15:0	0000 _{HEX}	SOT_sens[15:0]	Bits [15:0] of the 24-bit 2 nd order term <i>SOT_sens</i> applied to the sensor readout. (The MSBs of this term including sign are <i>SOT_sens</i> [23:16], which is bits [15:8] in 10 _{HEX} .)
0A _{HEX}	15:0	0000 _{HEX}	Offset_T[15:0]	Bits [15:0] of the 24-bit temperature offset correction coefficient <i>Offset_T</i> . (The MSBs of this coefficient including sign are <i>Offset_T</i> [23:16], which is bits [7:0] in 10 _{HEX} .)
0B _{HEX}	15:0	0000 _{HEX}	Gain_T[15:0]	Bits [15:0] of the 24-bit absolute value of the temperature gain coefficient <i>Gain_T</i> . (The MSBs of this coefficient including sign are <i>Gain_T</i> [23:16], which is bits [15:8] in 11 _{HEX} .)
0C _{HEX}	15:0	0000 _{HEX}	SOT_T[15:0]	Bits [15:0] of the 24-bit 2 nd -order term <i>SOT_T</i> applied to the temperature reading. (The MSBs of this coefficient including sign are <i>SOT_T</i> [23:16], which is bits [7:0] in 11 _{HEX} .)
0D _{HEX}	7:0	00 _{HEX}	Gain_S[23:16]	Bits [23:16] including sign for the 24-bit sensor gain correction coefficient <i>Gain_S</i> . (The LSBs of this coefficient are <i>Gain_S</i> [15:0] in register 04 _{HEX} .)
	15:8	00 _{HEX}	Offset_S[23:16]	Bits [23:16] including sign for the 24-bit sensor offset correction coefficient <i>Offset_S</i> . (The LSBs are <i>Offset_S</i> [15:0] in register 03 _{HEX} .)
0E _{HEX}	7:0	00 _{HEX}	Tco[23:16]	Bits [23:16] including sign for the 24-bit coefficient <i>Tco</i> for temperature correction for the sensor offset. (The LSBs are <i>Tco</i> [15:0] in register 06 _{HEX} .)
	15:8	00 _{HEX}	Tcg[23:16]	Bits [23:16] including sign for the 24-bit coefficient <i>Tcg</i> for the temperature correction of the sensor gain. (The LSBs are <i>Tcg</i> [15:0] in register 05 _{HEX} .)
0F _{HEX}	7:0	00 _{HEX}	SOT_tcg[23:16]	Bits [23:16] including sign for the 24-bit 2 nd order term <i>SOT_tcg</i> applied to <i>Tcg</i> . (The LSBs are <i>SOT_tcg</i> [15:0] in register 08 _{HEX} .)
	15:8	00 _{HEX}	SOT_tco[23:16]	Bits [23:16] including sign for the 24-bit 2 nd order term <i>SOT_tco</i> applied to <i>Tco</i> . (The LSBs are <i>SOT_tco</i> [15:0] in register 07 _{HEX} .)

MTP Address	Word / Bit Range	Default Setting	Description	Notes / Explanations
10 _{HEX}	7:0	00 _{HEX}	Offset_T[23:16]	Bits [23:16] including sign for the 24-bit temperature offset correction coefficient <i>Offset_T</i> . (The LSBs are <i>Offset_T</i> [15:0] in register 0A _{HEX} .)
	15:8	00 _{HEX}	SOT_sens[23:16]	Bits [23:16] including sign for the 24-bit 2 nd order term <i>SOT_sens</i> applied to the sensor readout. (The LSBs are <i>SOT_sens</i> [15:0] in register 09 _{HEX} .)
11 _{HEX}	7:0	00 _{HEX}	SOT_T[23:16]	Bits [23:16] including sign for the 24-bit 2 nd -order term <i>SOT_T</i> applied to the temperature reading. (The LSBs are <i>SOT_T</i> [15:0] in register 0C _{HEX} .)
	15:8	00 _{HEX}	Gain_T[23:16]	Bits [23:16] including sign for the 24-bit absolute value of the temperature gain coefficient <i>Gain_T</i> . (The LSBs are <i>Gain_T</i> [15:0] in register 0B _{HEX} .)
Measurement Configuration Register 1 (SM_config1)				
12 _{HEX}	2:0	000 _{BIN}	Gain_stage1	Gain setting for the 1 st PREAMP stage with <i>Gain_stage1</i> ⇔ <i>Gain_amp1</i> : 000 ⇔ 6 100 ⇔ 40 001 ⇔ 12 101 ⇔ 60 010 ⇔ 20 110 ⇔ 80 011 ⇔ 30 111 ⇔ 120 (might affect noise and accuracy specifications depending on sensor setup)
	5:3	000 _{BIN}	Gain_stage2	Gain setting for the 2 nd PREAMP stage with <i>Gain_stage2</i> ⇔ <i>Gain_amp2</i> : 000 ⇔ 1.1 100 ⇔ 1.5 001 ⇔ 1.2 101 ⇔ 1.6 010 ⇔ 1.3 110 ⇔ 1.7 011 ⇔ 1.4 111 ⇔ 1.8
	6	0 _{BIN}	Gain_polarity	Set up the polarity of the sensor bridge's gain (inverting of the chopper) with 0 ⇔ positive (no polarity change) 1 ⇔ negative (180° polarity change)
	10:7	0000 _{BIN}	Adc_bits	Absolute number of bits for the ADC conversion <i>ADC_bits</i> : 0000 ⇔ 12-bit 0101 ⇔ 17-bit 1010 ⇔ 22-bit 0001 ⇔ 13-bit 0110 ⇔ 18-bit 1011 ⇔ 23-bit 0010 ⇔ 14-bit 0111 ⇔ 19-bit 1100 ⇔ 24-bit 0011 ⇔ 15-bit 1000 ⇔ 20-bit 1101 to 1111 ⇔ not assigned 0100 ⇔ 16-bit 1001 ⇔ 21-bit
	11	0 _{BIN}	AbsV_enable	Enable bit for thermopile input selection (INN connected to AGND, INP connected to absolute voltage source) with <i>AbsV_enable</i> : 0 ⇔ absolute voltage input disabled (default) 1 ⇔ absolute voltage input enabled (e.g., for a thermopile)

MTP Address	Word / Bit Range	Default Setting	Description	Notes / Explanations
	14:12	000 _{BIN}	Offset	Differential signal's offset shift in the ADC; compensation of signal offset by x% of input signal: 000 ⇔ no offset compensation 100 ⇔ 25% offset 001 ⇔ 6.75% offset 101 ⇔ 31.75% offset 010 ⇔ 12.5% offset 110 ⇔ 38.5% offset 011 ⇔ 19.25% offset 111 ⇔ 43.25% offset Note: <i>Shift_method</i> (bit 15 below) must be set to 1 to enable the offset shift.
	15	0 _{BIN}	Shift_method	Offset shift method selection: 0 ⇔ No offset shift. <i>Offset</i> (bits [14:12] in 12 _{HEX}) must be set to 000 _{BIN} ; <i>Gain_{ADC}</i> = 1 1 ⇔ Offset shift ADC; <i>Gain_{ADC}</i> = 2
13 _{HEX}	15:0	0000 _{HEX}	TRSH1[15:0]	Bits [15:0] of the 24-bit interrupt threshold1, <i>TRSH1</i> . (The MSB bits for this threshold are <i>TRSH1</i> [23:16], which is bits [7:0] of register 15 _{HEX} .)
14 _{HEX}	15:0	0000 _{HEX}	TRSH2[15:0]	Bits [15:0] of the 24-bit interrupt threshold2, <i>TRSH2</i> . (The MSB bits for this threshold are <i>TRSH2</i> [23:16], which is bits [15:8] of register 15 _{HEX} .)
15 _{HEX}	7:0	00 _{HEX}	TRSH1[23:16]	Bits [23:16] of the 24-bit interrupt threshold1, <i>TRSH1</i> . (The LSB bits for this threshold are <i>TRSH1</i> [15:0], which is bits [15:0] of register 13 _{HEX} .)
	15:8	00 _{HEX}	TRSH2[23:16]	Bits [23:16] of the 24-bit interrupt threshold2, <i>TRSH2</i> . (The LSB bits for this threshold are <i>TRSH2</i> [15:0], which is bits [15:0] of register 14 _{HEX} .)
Measurement Configuration Register 2 (SM_config2)				
16 _{HEX}	2:0	000 _{BIN}	Gain_stage1	Gain setting for the 1 st PREAMP stage with <i>Gain_stage1</i> ⇔ <i>Gain_{amp1}</i> : 000 ⇔ 6 100 ⇔ 40 001 ⇔ 12 101 ⇔ 60 010 ⇔ 20 110 ⇔ 80 011 ⇔ 30 111 ⇔ 120 (might affect noise and accuracy specifications depending on sensor setup)
	5:3	000 _{BIN}	Gain_stage2	Gain setting for the 2 nd PREAMP stage with <i>Gain_stage2</i> ⇔ <i>Gain_{amp2}</i> : 000 ⇔ 1.1 100 ⇔ 1.5 001 ⇔ 1.2 101 ⇔ 1.6 010 ⇔ 1.3 110 ⇔ 1.7 011 ⇔ 1.4 111 ⇔ 1.8
	6	0 _{BIN}	Gain_polarity	Set up the polarity of the sensor bridge's gain (inverting of the chopper) with 0 ⇔ positive (no polarity change) 1 ⇔ negative (180° polarity change)
	10:7	0000 _{BIN}	Adc_bits	Absolute number of bits for the ADC conversion <i>ADC_bits</i> : 0000 ⇔ 12-bit 0101 ⇔ 17-bit 1010 ⇔ 22-bit 0001 ⇔ 13-bit 0110 ⇔ 18-bit 1011 ⇔ 23-bit 0010 ⇔ 14-bit 0111 ⇔ 19-bit 1100 ⇔ 24-bit 0011 ⇔ 15-bit 1000 ⇔ 20-bit 1101 to 1111 ⇔ not assigned 0100 ⇔ 16-bit 1001 ⇔ 21-bit

MTP Address	Word / Bit Range	Default Setting	Description	Notes / Explanations
	11	0 _{BIN}	AbsV_enable	Enable bit for thermopile input selection (INN connected to AGND, INP connected to absolute voltage source) with <i>AbsV_enable</i> : 0 ⇔ absolute voltage input disabled (default) 1 ⇔ absolute voltage input enabled (e.g. for a thermopile)
	14:12	000 _{BIN}	Offset	Differential signal's offset shift in the ADC; compensation of signal offset by x% of input signal: 000 ⇔ no offset compensation 001 ⇔ 6.75% offset 010 ⇔ 12.5% offset 011 ⇔ 19.25% offset 100 ⇔ 25% offset 101 ⇔ 31.75% offset 110 ⇔ 38.5% offset 111 ⇔ 43.25% offset Note: <i>Shift_method</i> (bit 15 below) must be set to 1 to enable the offset shift.
	15	0 _{BIN}	Shift_method	Offset shift method selection: 0 ⇔ No offset shift. <i>Offset</i> (bits[14:12] in 16 _{HEX}) must be set to 000 _{BIN} ; <i>Gain_{ADC}</i> = 1 1 ⇔ Offset Shift ADC, <i>Gain_{ADC}</i> = 2
Post-Calibration Offset Correction Coefficients				
17 _{HEX}	15:0	0000 _{HEX}	SENS_Shift[15:0]	Bits [15:0] of the post-calibration sensor offset shift coefficient <i>SENS_Shift</i> . (The MSB bits of <i>SENS_Shift</i> are bits [7:0] of register 19 _{HEX} .)
18 _{HEX}	15:0	0000 _{HEX}	T_Shift[15:0]	Bits [15:0] of the post-calibration temperature offset shift coefficient <i>T_Shift</i> . (The MSB bits of <i>T_Shift</i> are bits [15:8] of register 19 _{HEX} .)
19 _{HEX}	7:0	00 _{HEX}	SENS_Shift[23:16]	Bits [23:16] of the post-calibration sensor offset shift coefficient <i>SENS_Shift</i> . (The LSB bits of <i>SENS_Shift</i> are in register 17 _{HEX} .)
	15:8	00 _{HEX}	T_Shift[23:16]	Bits [23:16] of the post-calibration temperature offset shift coefficient <i>T_Shift</i> . (The LSB bits of <i>T_Shift</i> are in register 18 _{HEX} .)
Free Memory – Arbitrary Use				
20 _{HEX}	15:0	0000 _{HEX}		Not assigned (e.g., can be used for <i>Cust_IDx</i> customer identification number)
21 _{HEX}	15:0	0000 _{HEX}		Not assigned (e.g., can be used for <i>Cust_IDx</i> customer identification number)
...				Not assigned (e.g., can be used for <i>Cust_IDx</i> customer identification number)
37 _{HEX}	15:0	0000 _{HEX}		Not assigned (e.g., can be used for <i>Cust_IDx</i> customer identification number)
38 _{HEX}	15:0	0000 _{HEX}		Not assigned (e.g., can be used for <i>Cust_IDx</i> customer identification number)
39 _{HEX}	15:0	-	Checksum	Checksum generated for the entire memory through a linear feedback shift register (LFSR); signature is checked on power-up to ensure memory content integrity

The memory integrity checksum (referred to as *CRC*) is generated through a linear feedback shift register with the following polynomial:

$$g(x) = x^{16} + x^{15} + x^2 + 1 \quad \text{with the initialization value: FFFF}_{\text{HEX}}.$$

If the CRC is valid, then the “Memory Error” status bit is set to 0.

6.7 Calibration Sequence

Calibration essentially involves collecting raw signal and temperature data from the sensor-ZSSC3224 system for different known sensor-element values (i.e., for a resistive bridge or an absolute voltage source) and temperatures. This raw data can then be processed by the calibration master (assumed to be the user’s computer), and the calculated calibration coefficients can then be written to on-chip memory.

Here is a brief overview of the three main steps involved in calibrating the ZSSC3224.

Assigning a unique identification to the ZSSC3224. This identification is written to shadow RAM and programmed in MTP memory. This unique identification can be stored in the two 16-bit registers dedicated to the customer ID (00_{HEX} and 01_{HEX}; see Table 6.5). It can be used as an index into a database stored on the calibration PC. This database will contain all the raw values of the connected sensor-element readings and temperature readings for that part, as well as the known sensor-element measurand conditions and temperature to which the sensor-element was exposed.

Data collection. Data collection involves getting uncorrected (raw) data from the external sensor at different known measurand values and temperatures. Then this data is stored on the calibration master using the unique identification of the device as the index to the database.

Coefficient calculation and storage in MTP memory. After enough data points have been collected to calculate all the desired coefficients, the coefficients can be calculated by the calibration master. Then the coefficients can be programmed to the MTP memory.

Result. The sensor signal and the characteristic temperature effect on output will be linearized according to the setup-dependent maximum output range.

It is essential to perform the calibration with a fixed programming setup during the data collection phase. In order to prevent any accidental incorrect processing, it is further recommended that the MTP memory setup is kept stable during the entire calibration process as well as in the subsequent operation. A ZSSC3224 calibration only fits the setup used during its calibration. Changes in functional parameters after a successful calibration can decrease the precision and accuracy performance of the ZSSC3224 as well as of the entire application.

The ZSSC3224 supports operation with different sensor setups by means of the *SM_config1* and *SM_config2* registers. However, only one calibration coefficient set is supported. Therefore, either an alternative ZSSC3224-external signal calibration using the alternate *SM_config* settings must be performed to ensure that the programmed SSC coefficients are valid for both setups, or a full reprogramming of the SSC coefficients must be performed each time the sensor setup is changed. The selection of the external sensor setup (i.e., the AFE configuration) can be done with the interface commands B0_{HEX} and B1_{HEX} (see Table 6.1).

6.7.1 Calibration Step 1 – Assigning Unique Identification

Assign a unique identification number to the ZSSC3224 by using the memory write command (40_{HEX} + data and 41_{HEX} + data; see Table 6.1 and Table 6.5) to write the identification number to *Cust_ID0* at memory address 00_{HEX} and *Cust_ID1* at address 01_{HEX} as described in section 6.6.1. These two 16-bit registers allow for more than 4 billion unique devices.

6.7.2 Calibration Step 2 – Data Collection

The number of unique points (measurand and/or temperature) at which calibration must be performed generally depends on the requirements of the application and the behavior of the sensor in use. The minimum number of points required is equal to the number of correction coefficients to be corrected with a minimum of three different temperatures at three different sensor values. For a full calibration resulting in values for all 7 possible (external) sensor coefficients and 3 possible temperature coefficients, a minimum of 7 pairs of sensor with temperature measurements must be collected.

Within this minimum field of 3 measurand measurements x 3 temperature measurements, data must be collected for the specific value pairs (at known conditions) and then processed to calculate the coefficients. In order to obtain the potentially best and most robust coefficients, it is recommended that measurement pairs (temperature versus measurand) be collected at the outer corners of the intended operation range or at least at points that are located far from each other. It is also essential to provide highly precise reference values as nominal, expected values. The measurement precision of the external calibration-measurement equipment should be ten times more accurate than the expected ZSSC3224 output accuracy after calibration in order to avoid accuracy losses caused by the nominal reference values (e.g., measurand signal and temperature deviations).

Note: The coefficients *SENS_shift* and *T_shift* must not be determined during this calibration step.

Strong recommendation: Set these coefficients to zero until after initial calibration.

Note: *An appropriate selection of measurement pairs can significantly improve the overall system performance.*

The determination of the measurand-related coefficients will use all of the measurement pairs. For the temperature-related correction coefficients, 3 of the measurement pairs (at three different temperatures) will be used.

Note: *There is an inherent redundancy in the 7 sensor-related and 3 temperature-related coefficients. Since the temperature is a necessary output (which also needs correction), the temperature-related information is mathematically separated, which supports faster and more efficient DSP calculations during the normal usage of the sensor-ZSSC3224 system.* The recommended approach for data collection is to make use of the raw-measurement commands described in Table 6.2.

For external sensor values, either of the following commands can be used depending on the user's requirements:

- $A2_{\text{HEX}} + 0000_{\text{HEX}}$ Single sensor measurement for which the configuration register will be loaded from the *SM_config1* register (12_{HEX} in MTP); preprogramming the measurement setup in the MTP is required.

Note: *SM_config1* is the default configuration. Alternatively, *SM_config2* (16_{HEX} in MTP) can be used by first sending the command $B1_{\text{HEX}}$ (see section 6.7.5).

- $A3_{\text{HEX}} + \text{ssss}_{\text{HEX}}$ Single sensor measurement for which the *SM_config* configuration register (Gain, ADC, Offset, etc.) will be loaded as the user's configuration *ssss_{HEX}*, which must be provided externally via the interface as the data part of this command.

For temperature values, either of the following commands can be used depending on the user's requirements:

- $A6_{\text{HEX}} + 0000_{\text{HEX}}$ Single temperature measurement for which the configuration register will be loaded from an internal temperature configuration register (preprogrammed by IDT in the MTP); preprogramming of the respective configuration is done by IDT prior to ZSSC3224 delivery. This is the recommended approach for temperature data collection.

- $A7_{\text{HEX}} + \text{ssss}_{\text{HEX}}$ Single temperature measurement for which the configuration register (Gain, ADC, Offset, etc.) will be loaded as the user's configuration *ssss_{HEX}*, which must be provided externally via the interface as the data part of this command. The format and purpose of these configuration bits must be according to the definitions for *SM_config* and valid for temperature measurement; in this case (bits [15:12] will be ignored).

6.7.3 Calibration Step 3a) – Coefficient Calculations

The math to perform the coefficient calculation is complicated and will not be discussed in detail. There is a brief overview in the next section. IDT provides software (DLLs) to perform the coefficient calculation (external to the sensor-ZSSC3224 system) based on auto-zero corrected values. After the coefficients are calculated, the final step is to write them to the MTP memory of the ZSSC3224.

6.7.4 Calibration Step 3b) – Post-Calibration Offset Correction

There are two special SSC coefficients, *SENS_shift* and *T_shift*. Normally, these coefficients must be set to zero during the initial sensor calibration. The primary purpose of these two coefficients is to cancel additional offset shifts that could occur during or after final sensor assembly; e.g. if a respective sensor is finally placed and soldered on an application board.

If the final sensor assembly induced any kind of offset (on either the temperature or external sensor signal), the respective influence can be directly compensated by means of the *SENS_shift* and *T_shift* coefficients without the need to change the original SSC coefficient set. However, this post-calibration offset correction must be done under known ambient conditions (i.e., sensor measurand and/or temperature).

6.7.5 SSC Measurements

After the completion of the calibration procedure, linearized external sensor and temperature readings can be obtained using the commands AA_{HEX} to AF_{HEX} as described in Table 6.1.

Typically, only one external sensor is used in a single analog configuration using the setup in the *SM_config1* MTP register (12_{HEX}). However, the ZSSC3224 can support a second analog configuration that is set up in the *SM_config2* MTP register (16_{HEX}). This might be useful in cases where only one sensor-ZSSC3224 pair must support the measurand ranges for two different external sensors that have different precisions, required amplification, and sensor offset.

If a respective switching between setups is to be performed, the SSC coefficients for the alternate external sensor must be handled with one of the following methods:

- The programmed SSC coefficients are not used for the alternate external sensor. The ZSSC3224 performs only a one-to-one transfer, i.e. no effective digital SSC correction – only a transfer of the auto-zero corrected raw ADC readings to the ZSSC3224 output without any scaling, etc.
- The coefficients are re-programmed each time the analog setup is changed.

SM_config1 is selected as the analog setup register by default, so no specific activation is needed if only *SM_config1* is used. If *SM_config2* will also be used, the activation command B1_{HEX} must be sent once prior to the measurement request. To switch to using *SM_config1*, the activation command B0_{HEX} must be sent prior to use. This activation must be refreshed after any power-on reset or RES pin reset.

6.8 The Calibration Math

6.8.1 Bridge Signal Compensation

The saturation check in the ZSSC3224 detects saturation effects of the internal calculation steps, allowing the final correction output to be determined despite the saturation. It is possible to get potentially useful signal conditioning results that have had an intermediate saturation during the calculations. These cases are detectable by observing the status bit 0 for each measurement result. Details about the saturation limits and the valid ranges for values are provided in the following equations.

The calibration math description assumes a calculation with integer numbers. The description is numerically correct concerning values, dynamic range, and resolution.

SOT_curve selects whether second-order equations compensate for sensor nonlinearity with a parabolic or S-shaped curve. The parabolic compensation is recommended for most sensor types.

For the following equations, the terms are as follows:

<i>S</i>	=	Corrected sensor reading output via I2C or SPI; range [0 _{HEX} to FFFFFFF _{HEX}]
<i>S_Raw</i>	=	Raw sensor reading from ADC after AZ correction; range [-7FFFF _{HEX} , 7FFFF _{HEX}]
<i>Gain_S</i>	=	Sensor gain term; range [-7FFFF _{HEX} , 7FFFF _{HEX}]
<i>Offset_S</i>	=	Sensor offset term; range [-7FFFF _{HEX} , 7FFFF _{HEX}]
<i>Tcg</i>	=	Temperature coefficient gain term; range [-7FFFF _{HEX} , 7FFFF _{HEX}]
<i>Tco</i>	=	Temperature coefficient offset term; range [-7FFFF _{HEX} , 7FFFF _{HEX}]
<i>T_Raw</i>	=	Raw temperature reading after AZ correction; range [-7FFFF _{HEX} , 7FFFF _{HEX}]
<i>SOT_tcg</i>	=	Second-order term for Tcg non-linearity; range [-7FFFF _{HEX} , 7FFFF _{HEX}]
<i>SOT_tco</i>	=	Second-order term for Tco non-linearity; range [-7FFFF _{HEX} , 7FFFF _{HEX}]
<i>SOT_sens</i>	=	Second-order term for sensor non-linearity; range [-7FFFF _{HEX} , 7FFFF _{HEX}]
<i>SENS_shift</i>	=	Post-calibration, post-assembly sensor offset shift; range [-7FFFF _{HEX} , 7FFFF _{HEX}]
$ \dots $	=	Absolute value
$[\dots]_{ll}^{ul}$	=	Bound/saturation number range from <i>ll</i> to <i>ul</i> , over/under-flow is reported as saturation in the status byte

The correction formula for the differential signal reading is represented as a two-step process depending on the *SOT_curve* setting.

Equations for the parabolic *SOT_curve* setting (*SOT_curve* = 0):

Simplified:

$$K_1 = 2^{23} + \frac{T_Raw}{2^{23}} * \left(\frac{4 * SOT_tcg}{2^{23}} * T_Raw + 4 * Tcg \right) \tag{1}$$

$$K_2 = 4 * Offset_S + S_Raw + \frac{T_Raw}{2^{23}} * \left(\frac{4 * SOT_tco}{2^{23}} * T_Raw + 4 * Tco \right) \tag{2}$$

$$Z_{SP} = \frac{4 * Gain_S}{2^{23}} * \frac{K_1}{2^{23}} * K_2 + 2^{23} \quad (\text{delimited to positive number range}) \tag{3}$$

$$S = \frac{Z_{BP}}{2^{23}} * \left(\frac{4 * SOT_sens}{2^{23}} * Z_{SP} + 2^{23} \right) + SENS_shift \quad (\text{delimited to positive number range}) \tag{4}$$

Complete:

$$K_1 = \left[2^{23} + \left[\frac{T_Raw}{2^{23}} * \left[\left[\frac{SOT_tcg}{2^{21}} * T_Raw \right]_{-2^{25}}^{2^{25}-1} + 4Tcg \right]_{-2^{25}}^{2^{25}-1} \right]_{-2^{25}}^{2^{25}-1} \right]_{-2^{25}}^{2^{25}-1} \tag{5}$$

$$K_2 = \left[4 * Offset_S + \left[S_Raw + \left[\frac{T_Raw}{2^{23}} * \left[\left[\frac{SOT_tco}{2^{21}} * T_Raw \right]_{-2^{25}}^{2^{25}-1} + 4Tco \right]_{-2^{25}}^{2^{25}-1} \right]_{-2^{25}}^{2^{25}-1} \right]_{-2^{25}}^{2^{25}-1} \right]_{-2^{25}}^{2^{25}-1} \tag{6}$$

$$Z_{SP} = \left[\left[\frac{Gain_S}{2^{21}} * \left[\left[\frac{K_1}{2^{23}} * K_2 \right]_{-2^{25}}^{2^{25}-1} \right]_{-2^{25}}^{2^{25}-1} + 2^{23} \right]_{-2^{25}}^{2^{25}-1} \right]_{-2^{25}}^{2^{25}-1} \tag{7}$$

$$B = \left[\frac{Z_{SP}}{2^{23}} * \left[\left[\frac{SOT_sens}{2^{21}} * Z_{BP} \right]_{-2^{25}}^{2^{25}-1} + 2^{23} \right]_{-2^{25}}^{2^{25}-1} + SENS_shift \right]_{-2^{25}}^{2^{24}-1} \tag{8}$$

Equations for the S-shaped SOT_curve setting (SOT_curve = 1):

Simplified:

$$Z_{SS} = \frac{4 * Gain_S}{2^{23}} * \frac{K_1}{2^{23}} * K_2 \tag{9}$$

$$S = \frac{Z_{SS}}{2^{23}} * \left(\frac{4 * SOT_sens}{2^{23}} * |Z_{SS}| + 2^{23} \right) + 2^{23} + SENS_shift \quad (\text{delimited to positive number range}) \tag{10}$$

Complete:

$$Z_{SS} = \left[\frac{Gain_S}{2^{21}} * \left[\frac{K_1}{2^{23}} * K_2 \right]_{-2^{25}}^{2^{25}-1} \right]_{-2^{25}}^{2^{25}-1} \tag{11}$$

$$S = \left[\left[\frac{Z_{SS}}{2^{23}} * \left[\frac{SOT_sens}{2^{21}} * |Z_{SS}| \right]_{-2^{25}}^{2^{25}-1} + 2^{23} \right]_{-2^{25}}^{2^{25}-1} + 2^{23} + SENS_shift \right]_{0}^{2^{24}-1} \tag{12}$$

6.8.2 Temperature Signal Compensation

Temperature is measured internally. Temperature correction contains both linear gain and offset terms as well as a second-order term to correct for any nonlinearities. For temperature, second-order compensation for nonlinearity is always parabolic.

For the following equations, the terms are as follows:

- T = Corrected temperature sensor reading output via I2C or SPI; range [0_{HEX} to FFFFFFF_{HEX}]
- Gain_T = Gain coefficient for temperature; range [-7FFFFFF_{HEX} to 7FFFFFF_{HEX}]
- T_Raw = Raw temperature reading after AZ correction; range [-7FFFFFF_{HEX} to 7FFFFFF_{HEX}]
- Offset_T = Offset coefficient for temperature; range [-7FFFFFF_{HEX} to 7FFFFFF_{HEX}]
- SOT_T = Second-order term for temperature source non-linearity; range [-7FFFFFF_{HEX} to 7FFFFFF_{HEX}]
- T_Shift = Shift for post-calibration/post-assembly offset compensation; range [-7FFFFFF_{HEX} to 7FFFFFF_{HEX}]

The correction formula is best represented as a two-step process as follows:

Simplified:

$$Z_T = \frac{4 * Gain_T}{2^{23}} * (T_Raw + 4 * Offset_T) + 2^{23} \quad (\text{delimited to positive number range}) \tag{13}$$

$$T = \frac{Z_T}{2^{23}} * \left(\frac{4 * SOT_T}{2^{23}} * Z_T + 2^{23} \right) + T_Shift \quad (\text{delimited to positive number range}) \tag{14}$$

Complete:

$$Z_T = \left[\left[\frac{Gain_T}{2^{21}} * [T_Raw + 4 * Offset_T]_{-2^{25}}^{2^{25}-1} \right]_{-2^{25}}^{2^{25}-1} + 2^{23} \right]_0^{2^{25}-1} \quad (15)$$

$$T = \left[\frac{Z_T}{2^{23}} * \left[\left[\frac{SOT_T}{2^{21}} * Z_T \right]_{-2^{25}}^{2^{25}-1} + 2^{23} \right]_{-2^{25}}^{2^{25}-1} + T_Shift \right]_0^{2^{24}-1} \quad (16)$$

6.8.3 Measurement Output Data Format

The data format and bit assignment of the raw measurement and SSC-corrected outputs of the ZSSC3224 are defined in the following tables. Any ADC measurement and SSC calculation output is formatted as a 24-bit data word, regardless of the effective ADC resolution used. The values are either in two's complement or sign-absolute format.

Table 6.6 Measurement Results of ADC Raw Measurement Request (Two's Complement)

Bit	23	22	21	20	...	1	0
Meaning, Weighting	-2^0	2^{-1}	2^{-2}	2^{-3}	...	2^{-22}	2^{-23}

Table 6.7 Calibration Coefficients (Factors and Summands) in Memory (Sign Magnitude)

Bit	23	22	21	20	...	1	0
Meaning, weighting	0=positive 1=negative	2^1	2^0	2^{-1}	...	2^{-20}	2^{-21}

Table 6.8 Output Results from SSC-Correction Math or DSP—Sensor and Temperature

Bit	23	22	21	20	...	1	0
Meaning, weighting	2^0	2^{-1}	2^{-2}	2^{-3}	...	2^{-22}	2^{-23}

Table 6.9 Interrupt Thresholds TRSH1 and TRSH2—Format as for SSC-Correction Math Output

Bit	23	22	21	20	...	1	0
Meaning, weighting	2^0	2^{-1}	2^{-2}	2^{-3}	...	2^{-22}	2^{-23}

7. Package Outline Drawings

7.1 ZSSD3224 Die Dimensional Drawings

Figure 7.1 provides an illustration of the approximate pad layout. See the *ZSSC3224 Technical Note – Delivery Specifications* for the die dimensions and related specifications.

Figure 7.1 Approximate ZSSC3224 Pad Layout

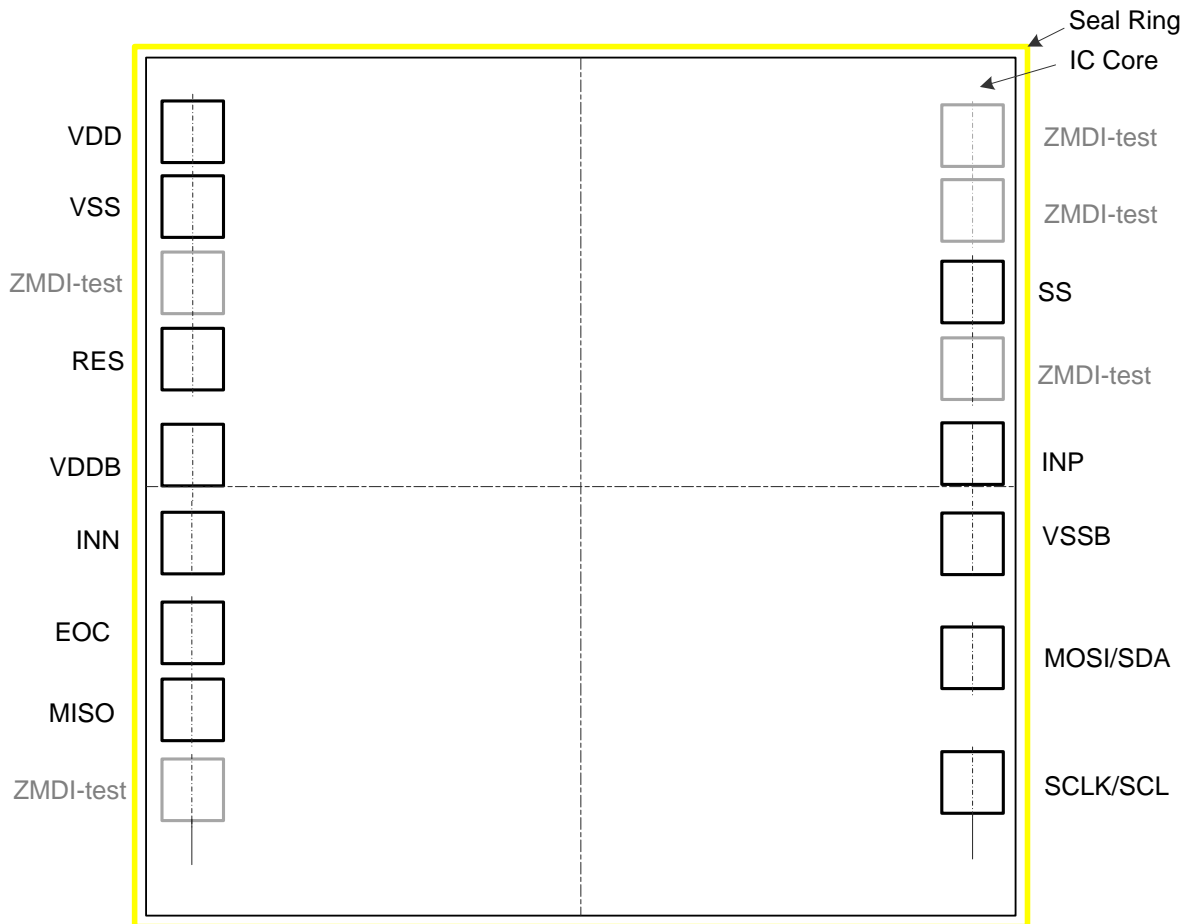

7.2 24-PQFN Package Dimensions

Figure 1.2 provides dimensions for the 24-PQFN package (ZSSC3224BI3R).

Figure 7.2 General 24-PQFN Package Dimensions

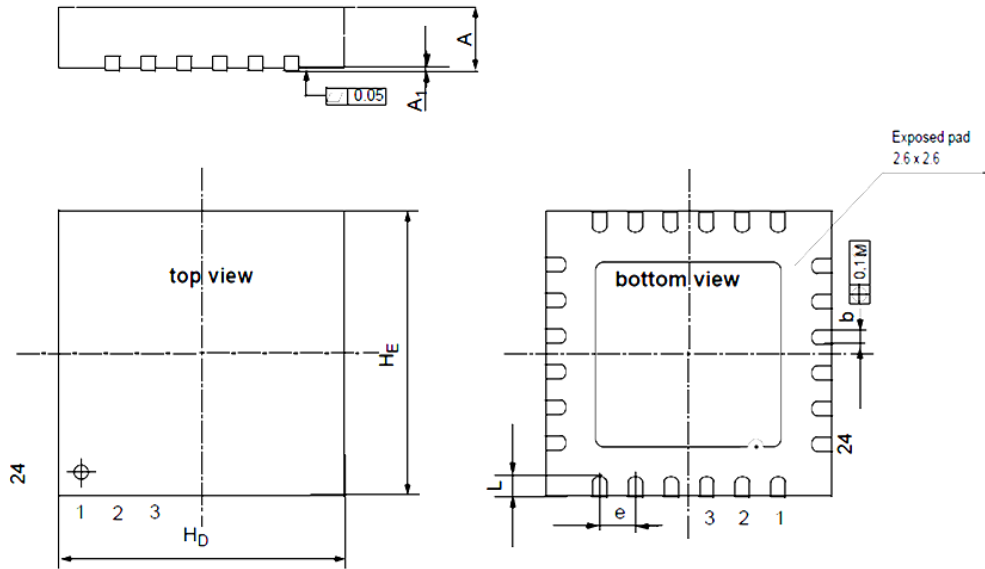

Table 7.1 Physical Package Dimensions

Parameter / Dimension	Min (mm)	Max (mm)
A	0.80	0.90
A ₁	0.00	0.05
b	0.18	0.30
e	0.5 nom	
H _D	3.90	4.10
H _E	3.90	4.10
L	0.35	0.45

8. Quality and Reliability

The ZSSC3224 is available as a qualified IC for consumer-market applications. All data specified parameters are guaranteed if not stated otherwise.

9. Related Documents

Visit the ZSSC3224 product page www.IDT.com/ZSSC3224 or contact your nearest sales office for the latest version of ZSSC3224 documents.

The following document is available on request: ZSSC3224 *Technical Note – Delivery Specifications*.

10. Glossary

Term	Description
A2D	Analog-to-Digital
ACK	Acknowledge (interface's protocol indicator for successful data/command transfer)
ADC	Analog-to-Digital Converter or Conversion
ALU	Arithmetic Logic Unit
AZ	Auto-Zero (unspecific)
AZSM	Auto-Zero Measurement for (external) Sensor Path
AZTM	Auto-Zero Measurement for Temperature Path
Au	Gold
CLK	Clock
Cu	Copper
DAC	Digital-to-Analog Conversion or Converter
DF	Data Fetch (command type)
DSP	Digital Signal Processor
EOC	End of Conversion
FSO	Full Scale Output (value in percent relative to the ADC maximum output code; resolution dependent)
LSB	Least Significant Bit
LFSR	Linear Feedback Shift Register
MR	Measurement Request (command type)
MSB	Most Significant Bit
MTP	Multiple-Time Programmable Memory
NACK	Not Acknowledge (interface's protocol indicator for unsuccessful data/command transfer)
POR	Power-on Reset
PreAmp	Preamplifier
PSRR	Power Supply Disturbance Rejection Ratio

Term	Description
SM	Signal Measurement
SOT	Second-Order Term
TC	Temperature Coefficient (of a resistor or the equivalent bridge resistance)
TM	Temperature Measurement

11. Marking Diagram

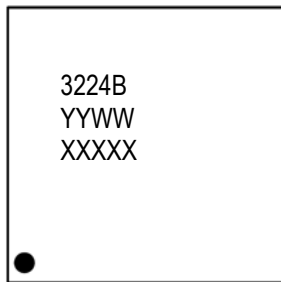

- Line 1 3224B the truncated part number
- Line 2 YYWW are the last 2 digits of the year and week that the part was assembled
- Line 3 Last 5 digits of lot number

12. Ordering Information

Contact IDT Sales for additional information.

Orderable Part Number	Description and Package	MSL Rating	Carrier Type	Temperature
ZSSC3224BI1B	ZSSC3224 die: thickness 304 μ m	Not applicable	Unsawn wafer	-40°C to +85 °C
ZSSC3224BI2B	ZSSC3224 die: thickness 725 μ m (without backlapping)	Not applicable	Unsawn wafer	-40°C to +85 °C
ZSSC3224BI3R	ZSSC3224 24-PQFN: 4.0 × 4.0 × 0.85 mm	MSL1	Reel	-40°C to +85 °C
ZSSC3224KITV1P0	Evaluation Kit for ZSSC3224, including boards, cable, software, and 5 samples			

13. Document Revision History

Date	Description
November 12, 2018	<ul style="list-style-type: none"> ▪ 24-PQFN is now available for production rather than as engineering samples. ▪ Update for template. ▪ Minor edits.
October 24, 2016	Correction for Table 4.1 The ADC "Conversion Rate" is 144Hz.
April 20, 2016	Changed to IDT branding. Revision number is now the release date.
January 14, 2016 (Rev. 1.00)	First release.

Notice

1. Descriptions of circuits, software and other related information in this document are provided only to illustrate the operation of semiconductor products and application examples. You are fully responsible for the incorporation or any other use of the circuits, software, and information in the design of your product or system. Renesas Electronics disclaims any and all liability for any losses and damages incurred by you or third parties arising from the use of these circuits, software, or information.
2. Renesas Electronics hereby expressly disclaims any warranties against and liability for infringement or any other claims involving patents, copyrights, or other intellectual property rights of third parties, by or arising from the use of Renesas Electronics products or technical information described in this document, including but not limited to, the product data, drawings, charts, programs, algorithms, and application examples.
3. No license, express, implied or otherwise, is granted hereby under any patents, copyrights or other intellectual property rights of Renesas Electronics or others.
4. You shall not alter, modify, copy, or reverse engineer any Renesas Electronics product, whether in whole or in part. Renesas Electronics disclaims any and all liability for any losses or damages incurred by you or third parties arising from such alteration, modification, copying or reverse engineering.
5. Renesas Electronics products are classified according to the following two quality grades: "Standard" and "High Quality". The intended applications for each Renesas Electronics product depends on the product's quality grade, as indicated below.
 - "Standard": Computers; office equipment; communications equipment; test and measurement equipment; audio and visual equipment; home electronic appliances; machine tools; personal electronic equipment; industrial robots; etc.
 - "High Quality": Transportation equipment (automobiles, trains, ships, etc.); traffic control (traffic lights); large-scale communication equipment; key financial terminal systems; safety control equipment; etc.Unless expressly designated as a high reliability product or a product for harsh environments in a Renesas Electronics data sheet or other Renesas Electronics document, Renesas Electronics products are not intended or authorized for use in products or systems that may pose a direct threat to human life or bodily injury (artificial life support devices or systems; surgical implantations; etc.), or may cause serious property damage (space system; undersea repeaters; nuclear power control systems; aircraft control systems; key plant systems; military equipment; etc.). Renesas Electronics disclaims any and all liability for any damages or losses incurred by you or any third parties arising from the use of any Renesas Electronics product that is inconsistent with any Renesas Electronics data sheet, user's manual or other Renesas Electronics document.
6. When using Renesas Electronics products, refer to the latest product information (data sheets, user's manuals, application notes, "General Notes for Handling and Using Semiconductor Devices" in the reliability handbook, etc.), and ensure that usage conditions are within the ranges specified by Renesas Electronics with respect to maximum ratings, operating power supply voltage range, heat dissipation characteristics, installation, etc. Renesas Electronics disclaims any and all liability for any malfunctions, failure or accident arising out of the use of Renesas Electronics products outside of such specified ranges.
7. Although Renesas Electronics endeavors to improve the quality and reliability of Renesas Electronics products, semiconductor products have specific characteristics, such as the occurrence of failure at a certain rate and malfunctions under certain use conditions. Unless designated as a high reliability product or a product for harsh environments in a Renesas Electronics data sheet or other Renesas Electronics document, Renesas Electronics products are not subject to radiation resistance design. You are responsible for implementing safety measures to guard against the possibility of bodily injury, injury or damage caused by fire, and/or danger to the public in the event of a failure or malfunction of Renesas Electronics products, such as safety design for hardware and software, including but not limited to redundancy, fire control and malfunction prevention, appropriate treatment for aging degradation or any other appropriate measures. Because the evaluation of microcomputer software alone is very difficult and impractical, you are responsible for evaluating the safety of the final products or systems manufactured by you.
8. Please contact a Renesas Electronics sales office for details as to environmental matters such as the environmental compatibility of each Renesas Electronics product. You are responsible for carefully and sufficiently investigating applicable laws and regulations that regulate the inclusion or use of controlled substances, including without limitation, the EU RoHS Directive, and using Renesas Electronics products in compliance with all these applicable laws and regulations. Renesas Electronics disclaims any and all liability for damages or losses occurring as a result of your noncompliance with applicable laws and regulations.
9. Renesas Electronics products and technologies shall not be used for or incorporated into any products or systems whose manufacture, use, or sale is prohibited under any applicable domestic or foreign laws or regulations. You shall comply with any applicable export control laws and regulations promulgated and administered by the governments of any countries asserting jurisdiction over the parties or transactions.
10. It is the responsibility of the buyer or distributor of Renesas Electronics products, or any other party who distributes, disposes of, or otherwise sells or transfers the product to a third party, to notify such third party in advance of the contents and conditions set forth in this document.
11. This document shall not be reprinted, reproduced or duplicated in any form, in whole or in part, without prior written consent of Renesas Electronics.
12. Please contact a Renesas Electronics sales office if you have any questions regarding the information contained in this document or Renesas Electronics products.

(Note1) "Renesas Electronics" as used in this document means Renesas Electronics Corporation and also includes its directly or indirectly controlled subsidiaries.

(Note2) "Renesas Electronics product(s)" means any product developed or manufactured by or for Renesas Electronics.

(Rev.4.0-1 November 2017)

Corporate Headquarters

TOYOSU FORESIA, 3-2-24 Toyosu,
Koto-ku, Tokyo 135-0061, Japan
www.renesas.com

Contact Information

For further information on a product, technology, the most up-to-date version of a document, or your nearest sales office, please visit:
www.renesas.com/contact/

Trademarks

Renesas and the Renesas logo are trademarks of Renesas Electronics Corporation. All trademarks and registered trademarks are the property of their respective owners.

X-ON Electronics

Largest Supplier of Electrical and Electronic Components

Click to view similar products for [Sensor Interface](#) category:

Click to view products by [Renesas](#) manufacturer:

Other Similar products are found below :

[ZSC31150GEG1-T](#) [ZSSC4161BE2W](#) [MCZ33784EF](#) [LM1815MX/NOPB](#) [FM-213-4-P](#) [MAX31850KATB+](#) [FM-252-4](#) [FM-215-8](#) [FM-216-AR2](#) [FM-253-4-P](#) [AS8510-ASSM](#) [AD598AD](#) [AD598JRZ](#) [AD598SD/883B](#) [743478D](#) [AD698APZ](#) [AD698SQ](#) [ADA4558WHCPZ-R7](#) [ADPD4000BCBZR7](#) [ADPD4001BCBZR7](#) [DRV401AIDWPR](#) [MAX1358BETL+](#) [MAX14827ATG+](#) [MAX14832ETB+](#) [MAX14838GTC+T](#) [MAX22520GWP+](#) [MAX31911AUI+](#) [RE46C803SS20](#) [MAX14826GTG+](#) [MAX1452AAE+](#) [MAX31855SASA+T](#) [MAX31855EASA+](#) [MAX31855SASA+](#) [MAX31855TASA+](#) [MAX31855KASA+T](#) [MAX31855NASA+](#) [MAX35102ETJ+](#) [MAX35103EHJ+](#) [MAX6682MUA+](#) [MAX86171ENI+](#) [MAX9921AUB+](#) [MAX9924UAUB+T](#) [MAX9925AUB+](#) [MAX9927AEE+](#) [MAX1454AUE/V+](#) [MAX1454AUE+](#) [RE46C800SS20](#) [SSC7102-GQ-AB2](#) [MAX6675ISA+](#) [MAX6674ISA+](#)