

RFIC 2019.05 Update Rev1.2

DESCRIPTION

The AP1286S is a linear, low current consumption RF Front-End Module (FEM) which consists of power amplifier, low noise amplifier and two T/R switches for ISM band wireless application. It offers highly integrated Input / Output matching on chip to reduce the bill of material. This RF FEM is developed for portable product of ISM band, and compact device or embedded module application of IoT with stable and outstanding performance.

AP1286S is housed in a 3 x 3 (mm), 16-pin, QFN leadless package, a high performance FEM.

KEY FEATURES

Tx:

- **Low current :**
37mA for 10dBm 3.3V FSK application
75mA for 18dBm 3.3V FSK application
91mA for 20dBm 3.3V FSK application

Rx:

- **Low current :**
13mA for 3.3V application
- **Low Noise Figure :**
2dB

Major Applications

- 802.15 PANs extended range device
- 2.4 GHz ISM Band portable device
- 2.4 GHz IoT Gateway device
- RF4CE application

Pin Assignment

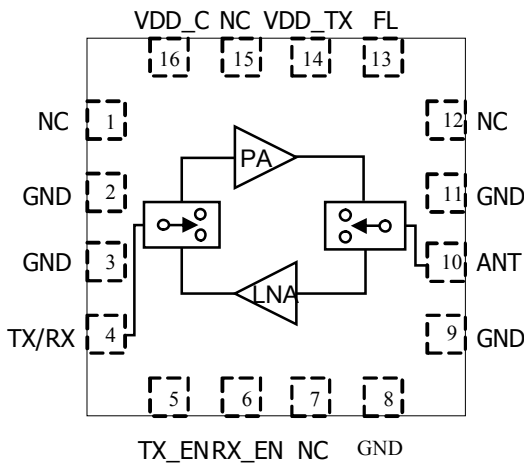

QFN-16pin, 3x3 (mm)

Pin Details

Pin Number	Name	Description
1	NC	No-used pin
2	GND	Connected to ground
3	GND	Connected to ground
4	TX/RX	RF signal from/to transceiver
5	TX_EN	Control signal input for TX path enable
6	RX_EN	Control signal input for RX path enable
7	NC	No-used pin
8	GND	Connected to ground
9	GND	Connected to ground
10	ANT	Antenna connection pin
11	GND	Connected to ground
12	GND	Connected to ground
13	FL	Keep Floating
14	VDD_TX	Supply voltage connection pin for TX
15	NC	No-used pin
16	VDD_C	Supply voltage connection pin for TX/RX
17	Center GND	IC center pad connected to ground

Tx Electrical Characteristics for general ISM band application

VDD_C = VDD_TXTX_EN = 3.3V; RX_EN = 0V; CW signal; TA = 25°C; unless otherwise noted.

Parameter	Specification			Units	Notes
	Min	Typ.	Max		
Freq	2.4		2.5	GHz	
Input return loss		10		dB	
Output return loss		5.5		dB	
P1dB		20.5		dBm	
Saturation Power			22	dBm	
Small Signal Gain		23	26	dB	
PAE		35		%	@ Pout = P1dB
2 nd Harmonics		-23		dBm/MHz	@ Pout = 20dBm
3 rd Harmonics		-22		dBm/MHz	@ Pout = 20dBm
Iref		0.25		mA	@ Pout = P1dB
Current Consumption		91		mA	@ Pout = 20dBm
		75			@ Pout = 18dBm
		56			@ Pout = 15dBm
		37			@ Pout = 10dBm

Rx Electrical Characteristics for general ISM band application

VDD_C = RX_EN = 3.3V; TX_EN = 0V; CW signal; TA = 25°C; unless otherwise noted.

Parameter	Specification			Units	Notes
	Min	Typ.	Max		
Freq	2.4		2.5	GHz	
Small Signal Gain		13		dB	
Noise Figure		2		dB	
Current Consumption		12		mA	
Input Return Loss		5		dB	
Output Return Loss		9		dB	
OP1dB		7		dBm	



Caution: ESD Sensitive
Appropriate precaution in handling, packaging
And testing devices must be observed.

RFIC 2019.05 Update Rev1.2

Absolute Maximum Ratings

Parameter	Rating	Unit
DC Power Supply For Drain	+4	V
DC Supply Current For Drain	300	mA
RF Input Power	+5	dBm
Operating Ambient Temperature	-40~85	°C
Storage Temperature	-40~125	°C
ESD (HBM, JESD22-A114, all pins)	300	V
Moisture Sensitivity	MSL3	

Logic Control Table

TX_EN	RX_EN	State
1	0	TX Active
0	1	RX Active

Note:

"1" = +3V to +3.3V

"0" = +0V to +0.2V

ISM Band General Application Reference Circuit

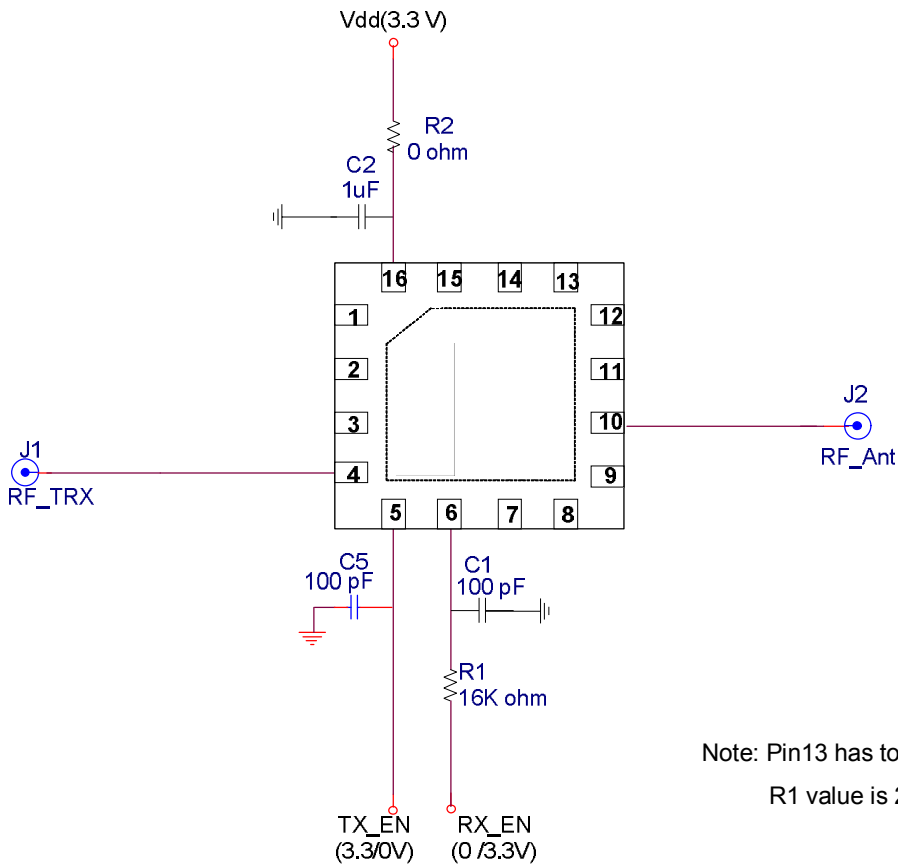

Note: Pin13 has to be NC.

R1 value is 24k ohm~16k ohm

Suggested PCB Layout

I/O Pin, Central PAD Layout

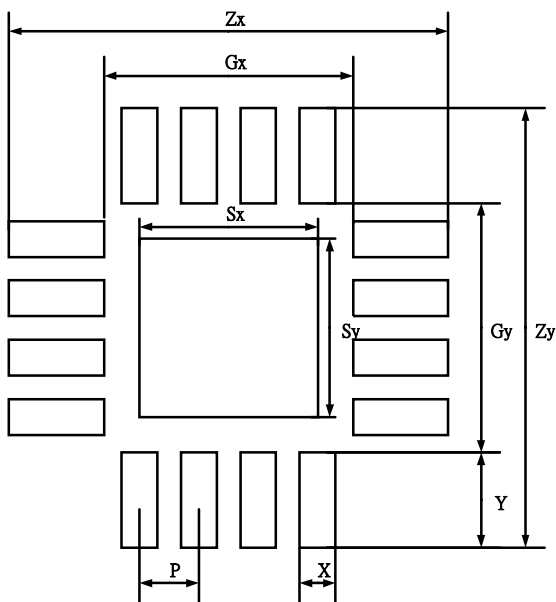

Thermal PAD Via Design

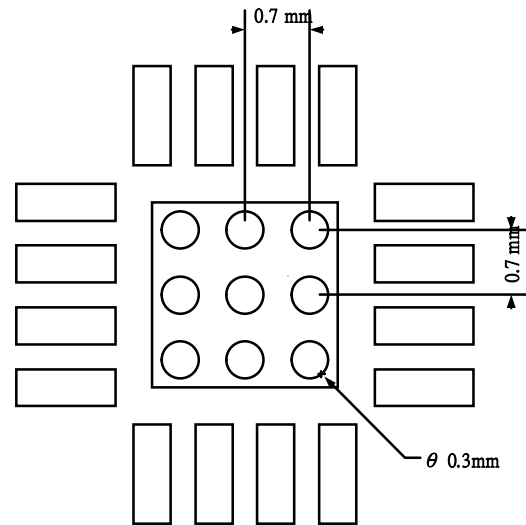

PCB Footprint Dimension (mm)								
P	X	Y	S _x	S _y	G _x	G _y	Z _x	Z _y
0.5	0.3	0.85	1.5	1.5	2.1	2.1	3.8	3.8

Package Outline

Top View

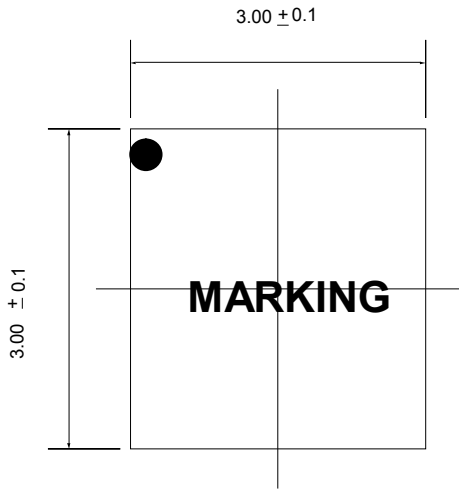

Bottom View

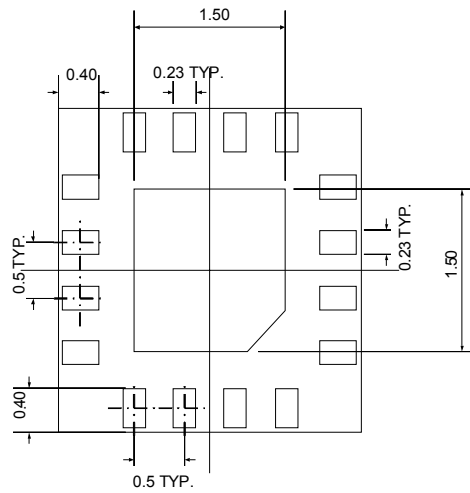

Side View

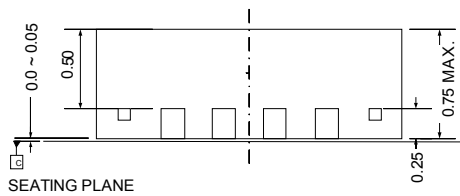

Unit: mm

Note :

1. Dimension and tolerance conform to ASME Y14.5M-1994.
2. Refer to JEDEC STD. MO-220 WEED-2 ISSUE B

Recommended Solder Reflow Profile

THERMOTRACKER 測溫報告

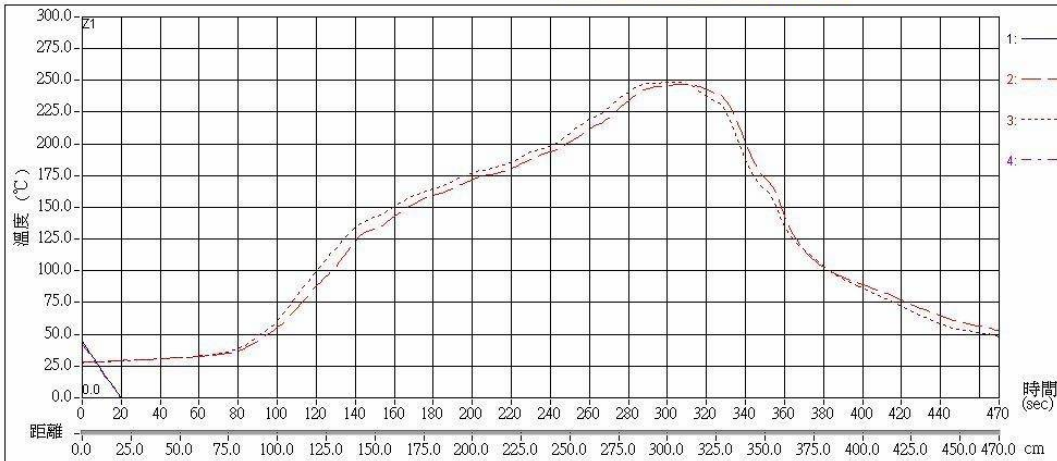

日期(日/月/年): 11/12/2007

公司名稱: 朗弗

產品名稱: QFN 3x3

速度設定值: 60.00 cm/Min

下載資訊

取樣速率(分:秒): 00:02.0

日期(日/月/年): 11/12/07

時間(時:分:秒): 17:21:53

資料檔名稱: THERMOTRACKER

各熱區溫度設定值(°C)及間距(cm)

熱區	Z1	Z2	Z3	Z4	Z5	Z6	Z7
TOP	180	190	190	200	240	291	275
BOTTOM	180	190	190	200	240	291	275
間距	0.0	0.0	0.0	0.0	0.0	0.0	0.0

備註

備註

最高溫度及時間分析

測溫點名稱	最高溫度(°C)	位於(秒)	高於220.7°C的時間(秒)	高於208.3°C的時間(秒)	高於210.6°C的時間(秒)
1	44.2	0.00	0.00	0.00	0.00
	247.2	308.00	64.00	82.00	78.00
	248.8	302.00	68.00	86.00	84.00
	42.1	0.00	0.00	0.00	0.00

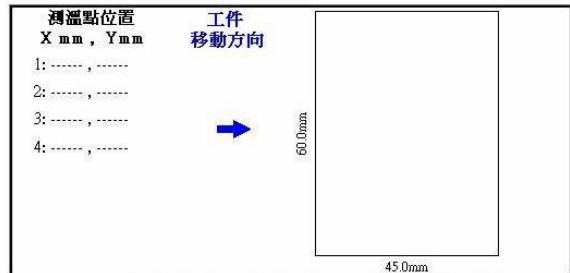

Copyright 2002 Tangeck Equipment Incorporated. E-mail: service@tangeck.com



RFIC 2019.05 Update Rev1.2

The product is designed and manufactured for consumer application only and is not intended for any application listed below which requires especially high reliability for the prevention of such defect which could lead to personal injury, death, physical or environmental damage.

- Aircraft equipment.
- Aerospace equipment.
- Undersea equipment.
- Medical equipment.
- Life-saving or life-sustaining applications
- Transportation equipment (vehicles, trains, ships, etc.).
- Traffic signal equipment.
- Disaster prevention / crime prevention equipment.
- Application of similar complexity and/ or reliability requirements to the applications listed in the above.

X-ON Electronics

Largest Supplier of Electrical and Electronic Components

Click to view similar products for [RF Amplifier](#) category:

Click to view products by [RFIC manufacturer](#):

Other Similar products are found below :

[ADPA7006AEHZ](#) [CXE2089ZSR](#) [MGA-43828-BLKG](#) [A82-1](#) [RF2878TR7](#) [BGA 728L7 E6327](#) [BGB719N7ESDE6327XTMA1](#) [HMC1126-SX](#) [HMC342](#) [HMC561-SX](#) [HMC598-SX](#) [HMC-ALH382-SX](#) [HMC-ALH476-SX](#) [SE2433T-R](#) [SE2622L-R](#) [SMA3101-TL-E](#) [SMA39](#) [SMA70-1](#) [A66-1](#) [A66-3](#) [A67-1](#) [LX5535LQ](#) [LX5540LL](#) [RF2373TR7](#) [HMC3653LP3BETR](#) [HMC395](#) [HMC549MS8GETR](#) [HMC576-SX](#) [HMC754S8GETR](#) [HMC-ALH435-SX](#) [SMA101](#) [SMA1031](#) [SMA181](#) [SMA32](#) [SMA411](#) [SMA531](#) [SST12LP17E-XX8E](#) [SST12LP19E-QX6E](#) [TGA2598](#) [WPM0510A](#) [HMC5929LS6TR](#) [HMC5879LS7TR](#) [HMC906A-SX](#) [HMC1127](#) [HMC544A](#) [HMC1126](#) [HMC1110-SX](#) [HMC1087F10](#) [HMC1086](#) [HMC1016](#)