

# 16Km LoRa Radio Telemetry Modules

## Features

- Upto 16km range line of sight
- FSK & LoRa Spread Spectrum
- 2 x Closed Contact Inputs
- 2 x Relay Switch Outputs
- Add-on Input/ Output channels
- Expandable to 16 I/P's and 32 O/P's
- All Signals 'Acknowledged'
- Watchdog Feature
- Walk / Range test Mode
- Many to Many Operation
- 12-32Vdc Supply
- LED Bar graph Signal indicator
- Easy 'Plug and Play' Installation
- 868MHz Version CE compliant
- 915MHz FCC Certified

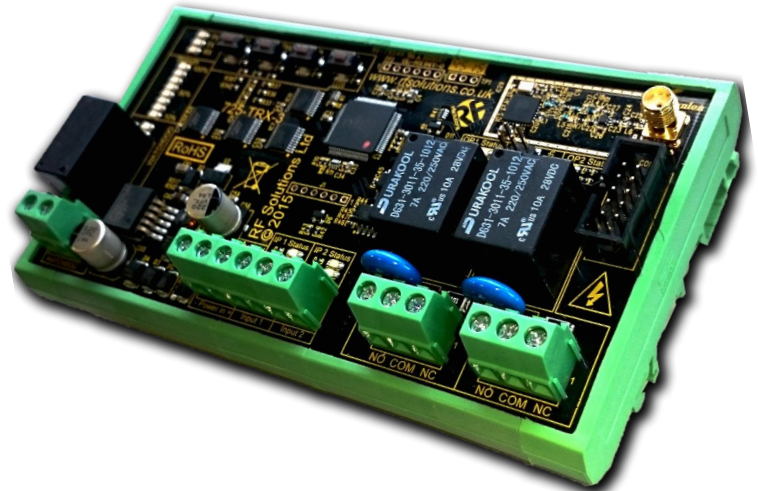

## Applications

- Industrial Telemetry
- Remote Monitoring & Control
- Reliable Remote Switch

The 725TRX telemetry system provides bi-directional, transceiver, remote Switch System. Each module has two switch inputs and two relay changeover contact outputs. When two or more modules are paired together the relay outputs will follow the state changes of the other modules' Inputs.

Additional input / output modules can be connected to provide extra inputs/outputs. The system inputs / outputs can be used in various ways and also with a hand held keyfob or alternative handset

All signals are acknowledged and a watchdog feature provides a system "Alive" indication . This is automatic, allowing the user to simply connect to the screw terminals and achieve a reliable telemetry link.

## Products Overview

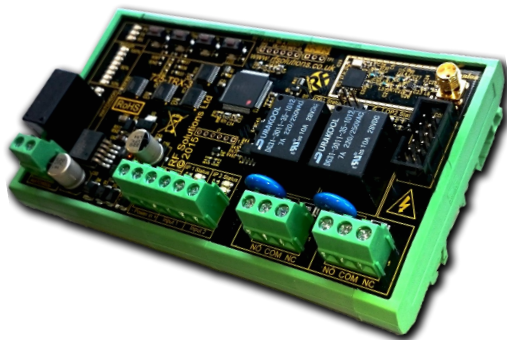

### 725TRX Transceiver

- Range up to 16Km line of sight.
- Self Contained Telemetry Transceiver
- 2 No volt inputs
- 2 Relay Outputs
- 1 Relay Watchdog output for Failsafe Operation
- All Connections via screw terminal
- Supply Voltage 12-32Vdc
- Supplied with antenna

Part Number	Description	Range*
725-TRX8-1K	868MHz Transceiver +13dBm	1km
725-TRX8-16	868MHz Transceiver +20dBm	16km
725-TRX9-1K	915MHz Transceiver +13dBm	1km
725-TRX9-16K	915MHz Transceiver +20dBm	16km

\* Range is quoted optimum LOS.

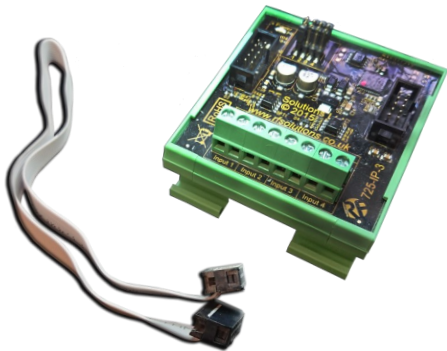

### 725-IP Additional 4 Switch Inputs

- Provides 4 additional inputs
- Connects Directly to 725TRX.
- Connecting ribbon cable supplied.
- Up to 16 725-IP may be Daisy Chained together.

Part Number	Description
725-IP	4 input Add-on Module

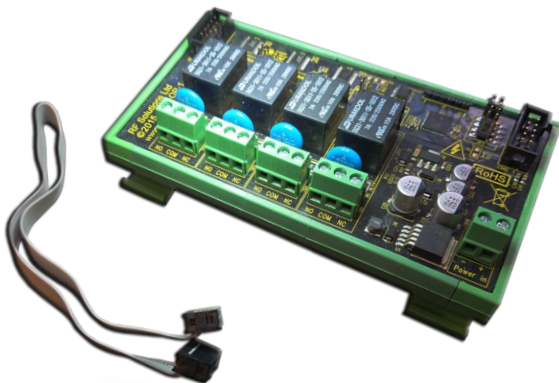

### 725-OP Additional 4 Relay Output board

- 4 Changeover Relay Outputs.
- Connecting ribbon cable supplied.
- Up to four 725-OP's can be Daisy Chained.

Part Number	Description
725-OP	4 Output Add-on Module

### 725-DOP 8 Channel Output board

- 8 Digital outputs for direct relay/contactor drive
- 0-30V operation range.
- 6A per channel.
- Connecting ribbon cable supplied.
- Up to four 725-DOP8 can be Daisy Chained.

Part Number	Description
725-DOP8	8 Output Add-on Module

## 725TRX Overview

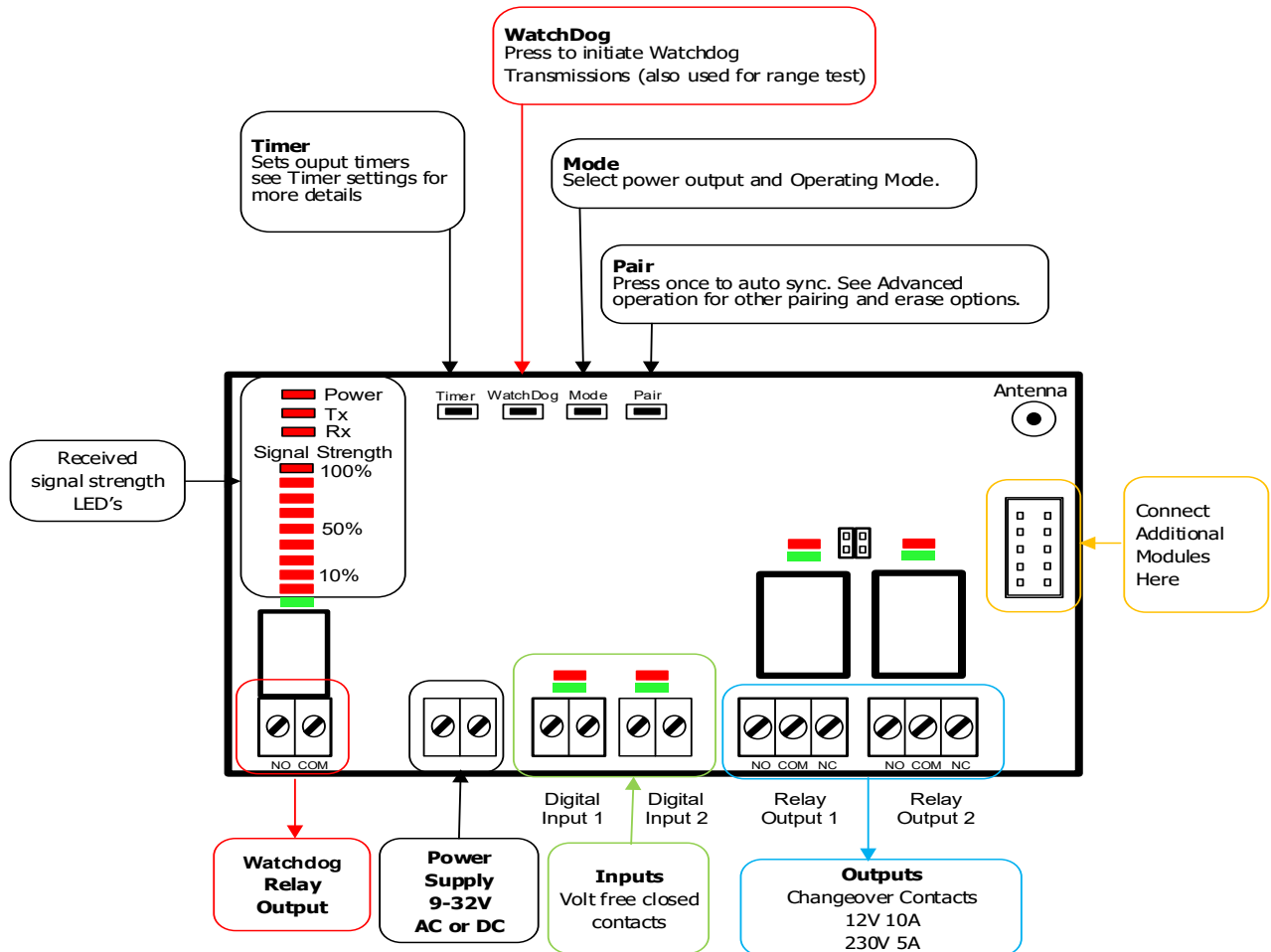

## Overview of Features

725TRX has many 'optional' features. These are summarised below and explained in detail later in this document.

**Auto or Manual Pairing:** Modules can be auto paired together in banks or any individual input can be paired to any individual output(s).

**WATCHDOG:** This is a relay contact which is held 'ON' as long as the Auto TX signal is received.

**RF Mode:** Time of operation can be traded with system range. For standard FM operation the outputs operate within 30 milliseconds, when LORA (Long Range) is enabled the time delay can be a couple of seconds. (16K version only)

**OUTPUTS:** The outputs can be set to Momentary/Latching /Timed.

**Additional Modules:** Additional Input and Output modules or a combination of both can be connect (max 4 input or output boards of any type).

**Note:** When using more than 2 output boards VCC must be connected to the 725-OP boards.

## Creating a Telemetry System using Two 725 TRX's

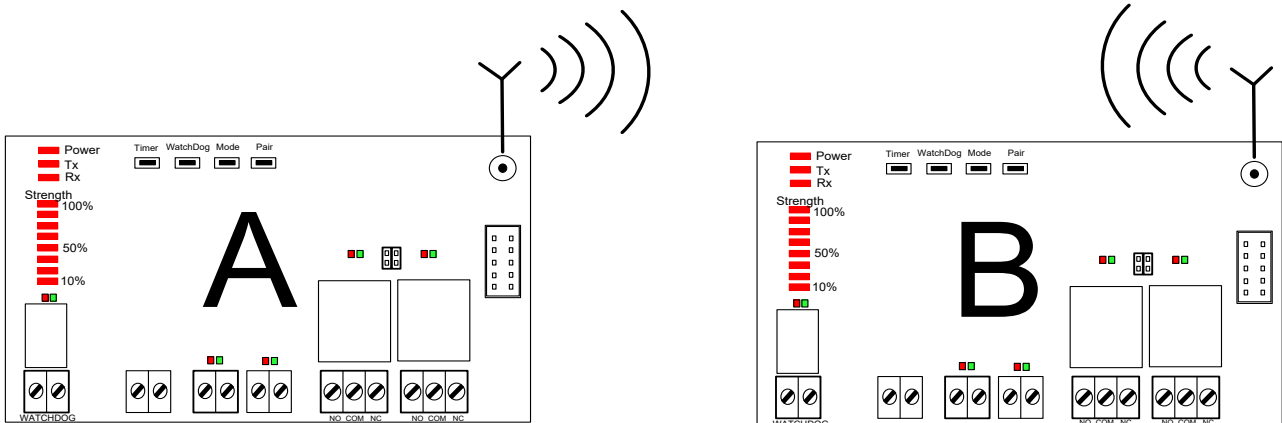

### Follow these Steps:

1. Connect to screw Terminal Inputs.
2. Connect to screw Terminal Outputs.
3. Pair Together 725TRX Modules A and B.
4. Set Output Jumper Links (Momentary or Latching).
5. Optional configuration: Auto TX / TIMERS / WATCHDOG / MODE.

## Pairing

### Factory Default Status:

In Factory default Input / Output LEDs flash Red/Green alternately

### To AUTO-PAIR A to B:

1. Press and release the PAIR button on the 725TRX B.
2. The pair and all relay output LED's will flash on 725TRX B
3. Activate ANY input on 725TRX A.
4. All flashing LEDs on 725TRX B relays will go out. The PAIR LED will flash quickly for 2 seconds .
5. Pairing Complete

### To PAIR A Input 1 to B Output 2:

1. Press and release the PAIR button on the 725TRX B to enter pair mode. Press and release the PAIR button to cycle through LED's until only the LED above Relay 2 is Flashing
2. Activate input 1 on 725TRX A.
3. All flashing LEDs on 725TRX B relays will go out, the PAIR LED will flash quickly for 2 seconds
4. Pairing Complete

### Please Note:

1. Manual pair will not work when auto pair has been used.
2. The max no of pairings is 32, this applies to individual inputs (or buttons on keyfob)  
E.g. a single 725-TRX can learn 32 individual 1 button FOBBER Keyfobs , or 8, 4 button FOBBER Keyfobs.

## Pairing a hand held transmitter

### To AUTO-PAIR a hand held transmitter:

1. Press and release the PAIR button on the 725TRX.
2. The pair and all relay output LED's will flash on 725TRX.\*
3. Activate ANY button on your transmitter.
4. All flashing LEDs on 725TRX relays will go out. The PAIR LED will flash quickly for 2 seconds .
5. Auto-Pair is Complete

**Note:** \*To Auto-Pair an output board you need to press the Pair button again and repeat until the desired 725-OP LEDs are flashing then continue from step 3.

### To PAIR a hand held transmitter button to Relay 2:

1. Press and release the PAIR button on the 725TRX to enter pair mode. Press and release the PAIR button to cycle through LED's until only the LED above Relay 2 is Flashing
2. Activate your chosen button on your transmitter.
3. All flashing LEDs on 725TRX relays will go out. The PAIR LED will flash quickly for 2 seconds .
4. Pairing is Complete

**Note:** \*To Pair an output board relay, you need to press the Pair button and repeat to cycle through LED's until only the LED above the desired 725-OP relay is flashing then continue from step 2.

**Please Note:** Manual pair will not work when auto pair has been used.

## Erasing

### Reset to Factory Default Setting:

The 725TRX may be reset to Factory default at any time by pressing the PAIR button for 15 seconds.

### Erasing Everything (reset to Factory Default):

1. Apply power
2. Press and hold the PAIR button for 15 seconds, the PAIR LED will flash slow then fast.
3. Release the PAIR button.
4. 725-TRX now reset to Factory Default

### ERASE Individual Transmitters:

1. Apply power
2. Press and hold the PAIR button for 10 seconds, the PAIR LED will flash slow as soon as this happens release the PAIR button.
3. Press any button on the transmitter to be erased.
4. The 725-TRX will exit to normal operating mode and the transmitter will be erased.

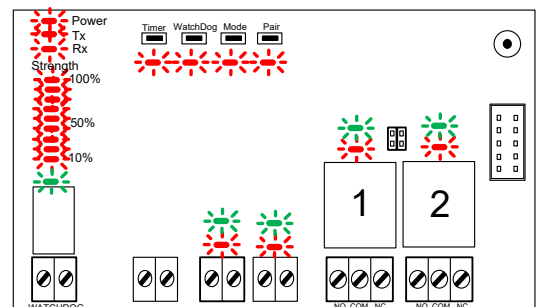

## INPUTs Status LEDs

Inputs are activated by a closed contact switch.

When the status of any input is changed 725TRX immediately broadcasts the status (of all inputs).

After receiving the transmitted RF signal, the paired 725TRX Transceiver(s) respond with an ACKNOWLEDGE RF Signal.

When the ACKNOWLEDGE signal is received back by the transmitting 725TRX it will be indicated on the input LED's.

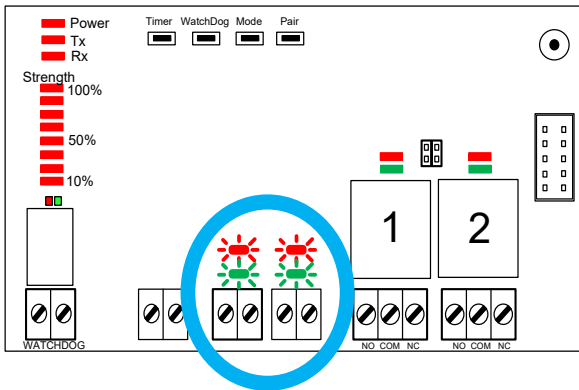

LED	Description
RED/GREEN Alternating	Input is not paired with any output
<b>GREEN LED</b>	<b>Status of Input</b>
ON	Input Active / ON
OFF	Input Inactive / OFF
<b>RED LED</b>	<b>Feedback from Receiver</b>
ON	After Power is applied and before transmitting any signal
OFF	Ack signal successfully received
Flashing	Failed to received the ack signal (out of Range)

## OUTPUTs Status LEDs

When the receiving 725TRX gets a valid signal from a paired device it will activate an output.

The status of active relays will be displayed on their corresponding LED's.

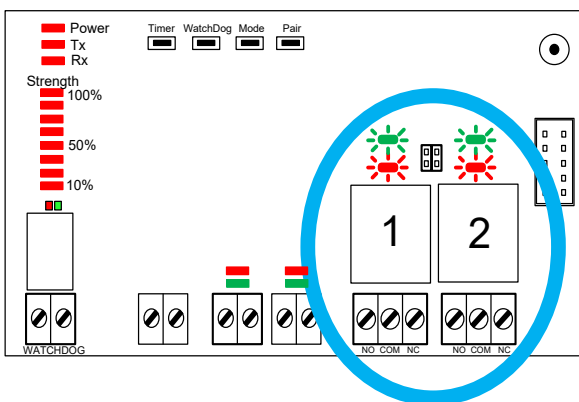

LED	Description
RED/GREEN Alternating	Output is not paired with any input
<b>GREEN LED</b>	<b>Status of Output</b>
ON	Relay is Active / ON
OFF	Relay is Inactive / OFF
<b>RED LED</b>	<b>Feedback from Receiver</b>
Flashing	Ready to pair

## MOMENTARY/LATCHING setting links

Each Relay Output can be individually pre-set to Momentary/Latching by fitting or removing the Link Headers

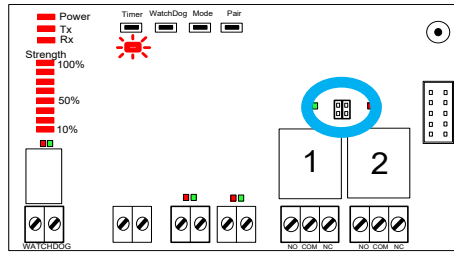

Link fitted	LATCHING	Output changes state on each Transmit signal
Link Removed	MOMENTARY	Output operates for duration of Transmit signal

## TIMER (Setting an Output Time Delay)

### Setting a Timed Output:

1. Briefly press the TIMER Switch.
2. The TIMER and first relay output LED's will flash.
3. Press the TIMER switch again to scroll through relays until the chosen relay LED is flashing.
4. Wait until the chosen relay LED is on constantly.
5. Now Each press of the timer button will increase the timer delay in line with the TIMER OUTPUT Table Displayed on the signal strength LED's.
6. When you have selected the required delay, wait 3 seconds.
7. The Red TIMER LED will Stop flashing to show that the setting is saved

**Note:** Settings are saved even after power is removed.

**Note:** When zero LED's are lit the relays will operate as per the Momentary/Latching links.

LED	Timer Output
8	60 min
7	30 min
6	10 min
5	1 min
4	30 sec
3	10 sec
2	5 sec
1	1/2 sec
0	Mom

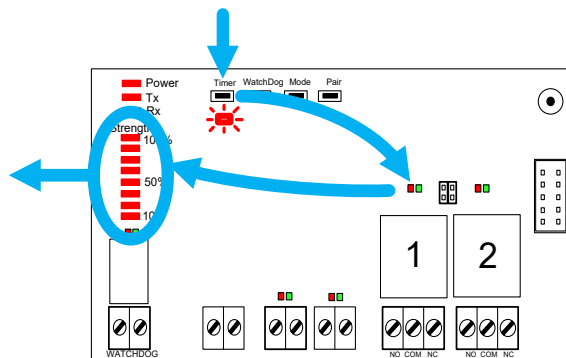

## Erase ALL Timers:

1. Press and hold the TIMER button for 10 seconds,
2. Whilst held the TIMER LED will turn on and then flash fast.
3. When the LED flashes fast release the timer button the erase is complete
- 4.

**Note:** When setting a Time Delay; If the Jumper Link is Removed the Time delay will restart on each transmission regardless of output status.

If the Jumper Link is Fitted, the Time delay output Will Latch OFF / ON Timed with each transmission.

## RF Mode of Operation

The 725 Transceivers can be configured to operate as standard FSK or LoRA Modes.

**FSK** = (FM) fixed frequency Carrier Frequency

**LoRA**– Long Range Spread Spectrum Frequency Hopping Protocol.

**FSK:** provides a fast Time of operation and is compatible with all other RF Solutions products at this frequency.

**LoRA** can be set to one of several modes of operation where the time of operation is extended but so also is the range.

LED	Mode	Typical RF Transmit Packet Time
8	LORA 7	1.28 Seconds
7	LORA 6	640 mSecs
6	LORA 5	320 mSecs
5	LORA 4	160 mSecs
4	LORA 3	80 mSecs
3	LORA 2	40 mSecs
2	LORA 1	20 mSecs
1	FSK	20 mSecs

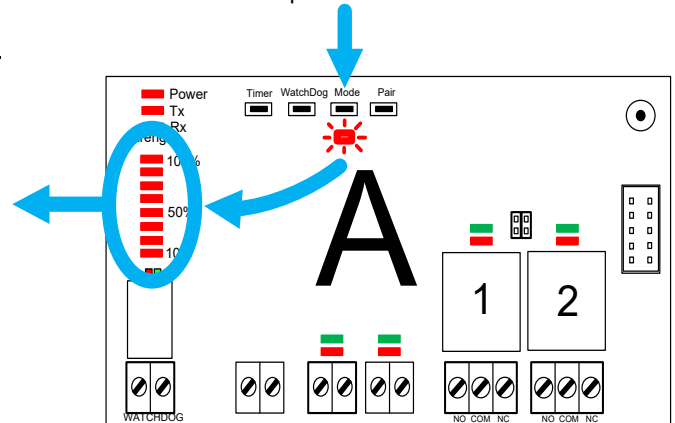

**Note:** 725-TRX '1K' versions can only operate in mode 1!

**Note:** 725-TRX9' will not operate in FSK mode and will start at mode 2

### To Set the Mode of operation

1. Press the MODE button momentarily the MODE LED will flash.
2. Repeat press the MODE button until the chosen LED / Mode is selected

## Walk / Range Test

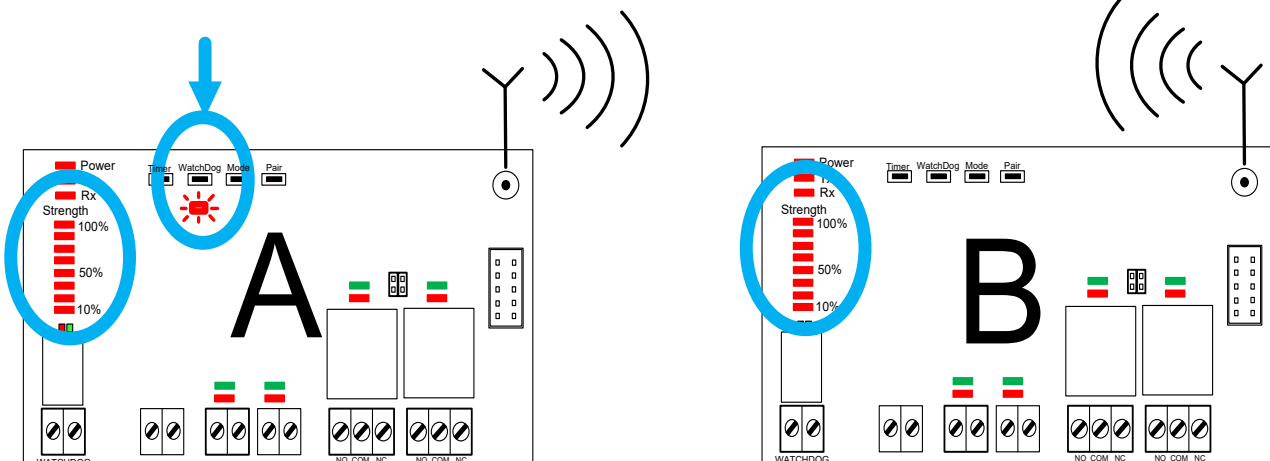

1. Press and hold the WatchDog button on the Transmitter for 5 seconds.
2. 725TRX emits a special Test transmission every second,
3. Any 725TRX will display the received Beacon on the signal strength LED bar graph.
4. An acknowledge will be sent back to the originating 725TRX by any paired 725TRX which will also display on its signal Strength LED bar graph
5. When activated on a paired transmitter, LEDs 1-8 on both devices will show signal strength - the more LEDs flashing, the better the signal.

**Notes:** For reliable communications we recommend 3 or more LED's are illuminated.



## Watchdog

This feature provides a System “Alive” failsafe function between Two 725TRX modules. When Watchdog is enabled a 725TRX automatically transmits a background Radio signal. Any paired 725TRX receiving an RF packet from another paired 725TRX it will activate its “Watchdog relay”. As long as the Watchdog relay is active the Radio signals are being received and working correctly.

## Enable a Watchdog Transmit

Briefly press the WDOG button, WDOG LED is illuminated and Watchdog transmissions will be activated. Repeat press the WDOG Button to select a Watchdog time interval

LED	WDOG Tx Interval
8	120 min
7	60 min
6	20 min
5	10 min
4	2 min
3	65 sec
2	45 sec
1	25 sec

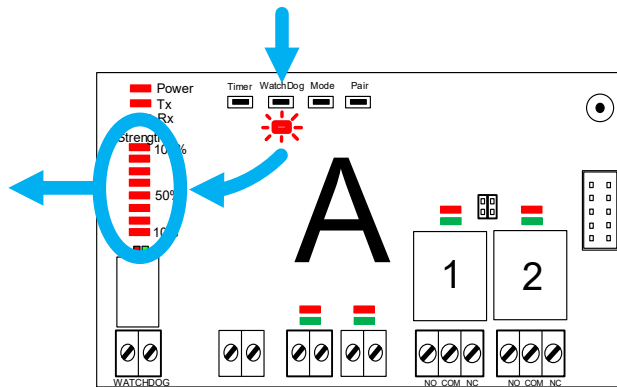

## Watchdog Relay Output

The watchdog relay will automatically be activated whenever an RF signal from a paired transmission is received (the WDOG button does not need to be pressed to receive)

As long as an RF signal is received from a paired 725TRX within the timeout period, then the Watchdog relay will be maintained “ON”

If an rf signal is not received within the watchdog Timeout period then the Watchdog relay will relax indicating a problem!

LED	Watchdog Timeout
8	360 min
7	180 min
6	60 min
5	30 min
4	6 min
3	195 sec
2	135 sec
1	80 sec

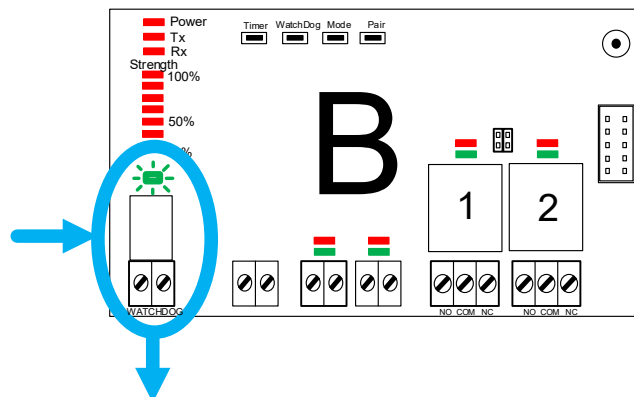

### Notes:

1. We recommend that the receiving 725 allows for at least 3 Auto TX time periods
2. The 725-TRX will need to be paired in both directions for both watchdog relays to operate. A 725-TRX can only receive a watchdog signal when paired as a receiver.
3. When using Lora and Watchdog. Ensure that the Auto Tx Signal interval allows enough time for the Lora signal to transmit!

## Additional Input / Output Modules

Upto 4 Input and 4 Output modules can be added (16 inputs and 16 outputs (725-OP) 32 outputs (725-DOP8) max).

Cables are supplied to enable the modules to plug and play.

Once the Address Links are selected, no other configuration is required the add on modules function as an extension of the 725TRX Module.

## 725-IP Additional 4 Inputs Module

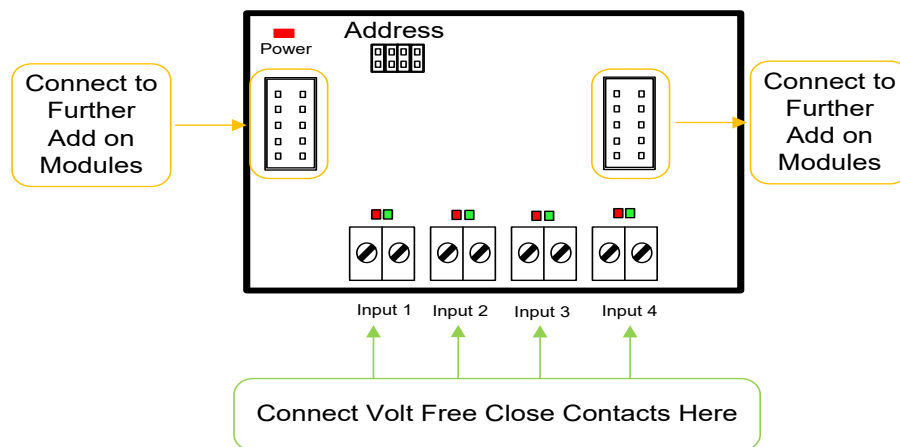

## 725-OP Additional 4 x Output Relays Module

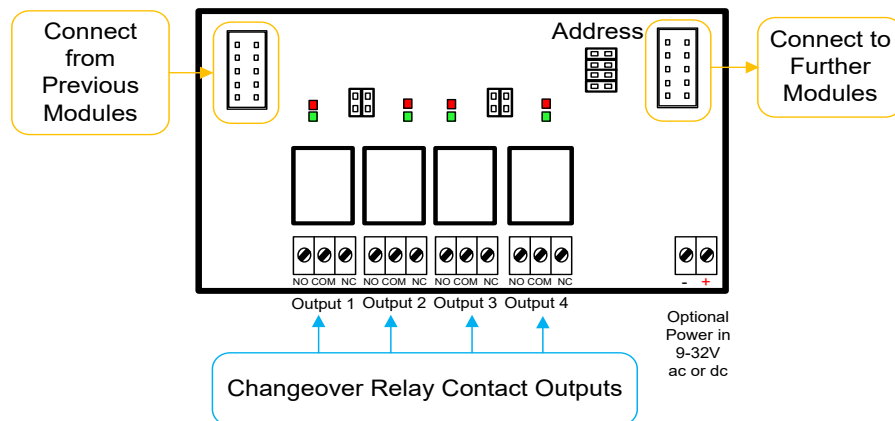

## 725-DOP8 Additional Outputs Module

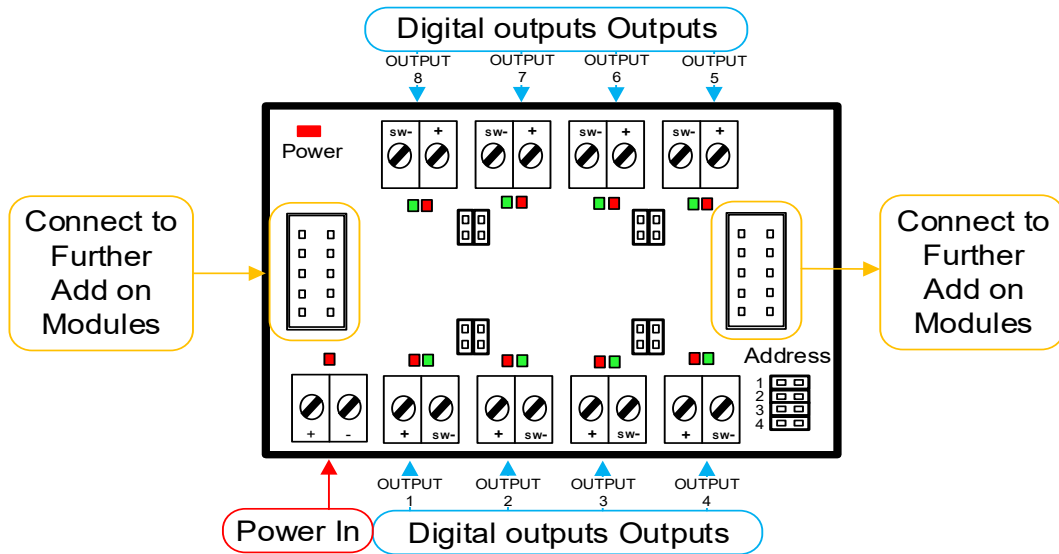

The 725-DOP8 module provides 8 Switching Outputs.

For each output, the +ve screw terminal is directly connected to the Power Supply +ve Voltage, When the output is activated the "SW" Screw Terminal is switched to GND.

The power supply for this module can be upto 30Vdc @6A enabling this module to switch higher voltages (e.g. contactors, PLC, or other switching logic)

## 725-DOP8 Output Schematic

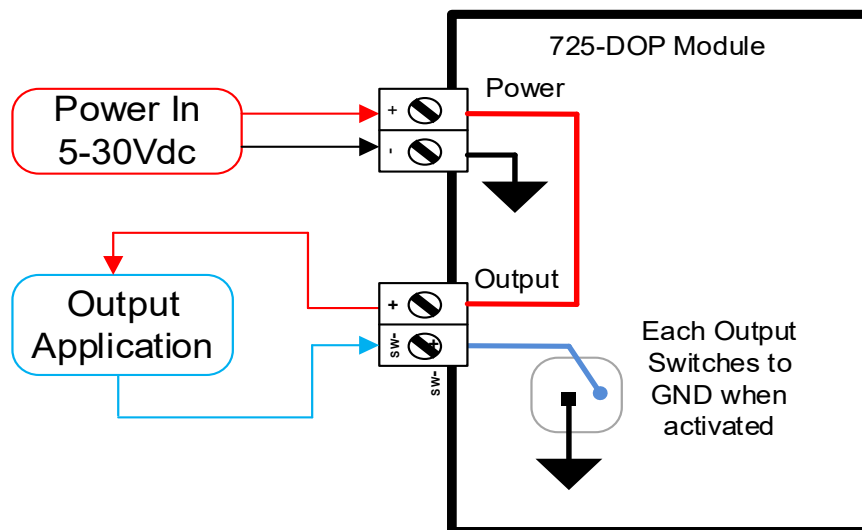

## Connecting Add-on Input / Output Modules

### Address settings:

Each module must have a unique address set by the Address jumpers (it doesn't matter what the address is)

**Note:** outputs will cycle in address order for pairing, timers and erasing.

### Connect to 725TRX:

Connect to the 725TRX or previous I/O module using the ribbon cable provided

**Note:** When connecting more than one 725-OP module the power must be connected directly to the 725-OP module screw terminals.

## Application Example A to B Telemetry

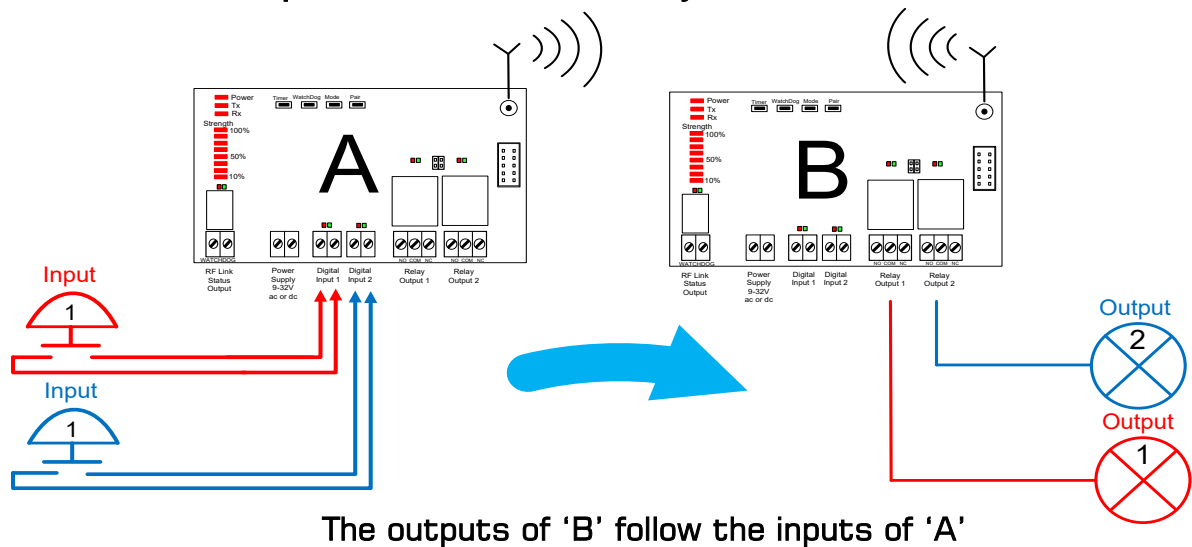

The outputs of 'B' follow the inputs of 'A'

## Application Example A to B and B to A Telemetry

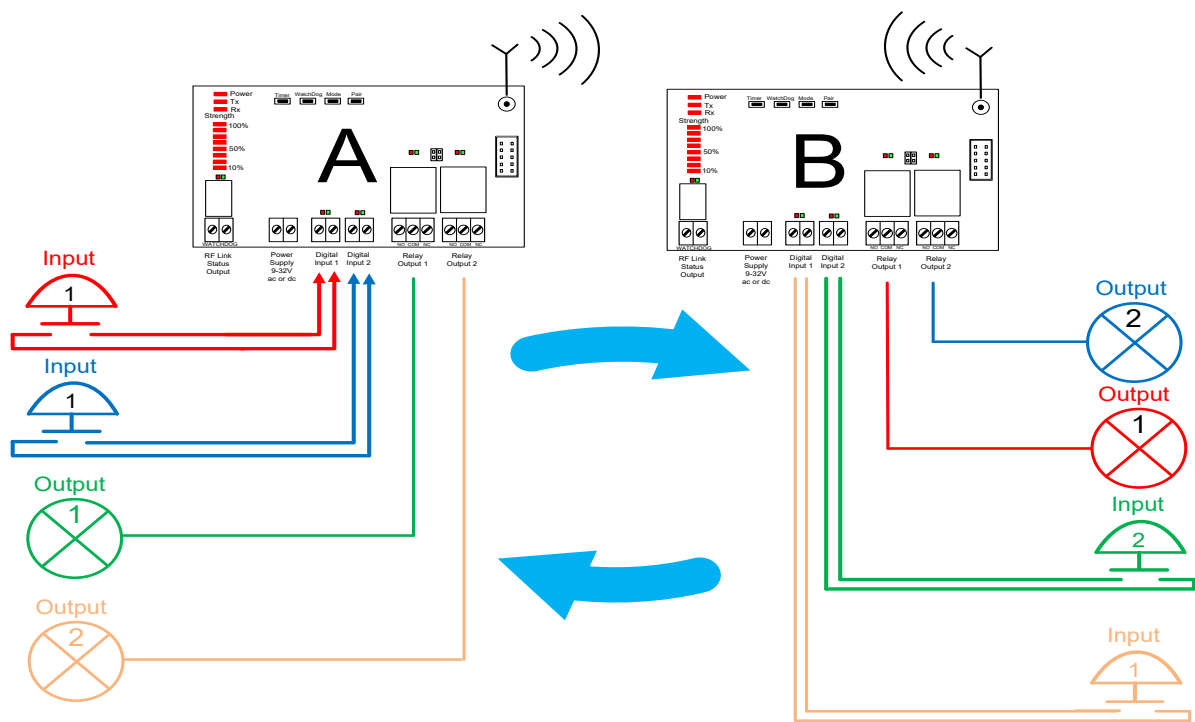

## Application Example using Multiple Add-on Modules

In this Below example;

'A' inputs are paired directly with 'B' Outputs

'B' inputs are paired directly with 'A' Outputs

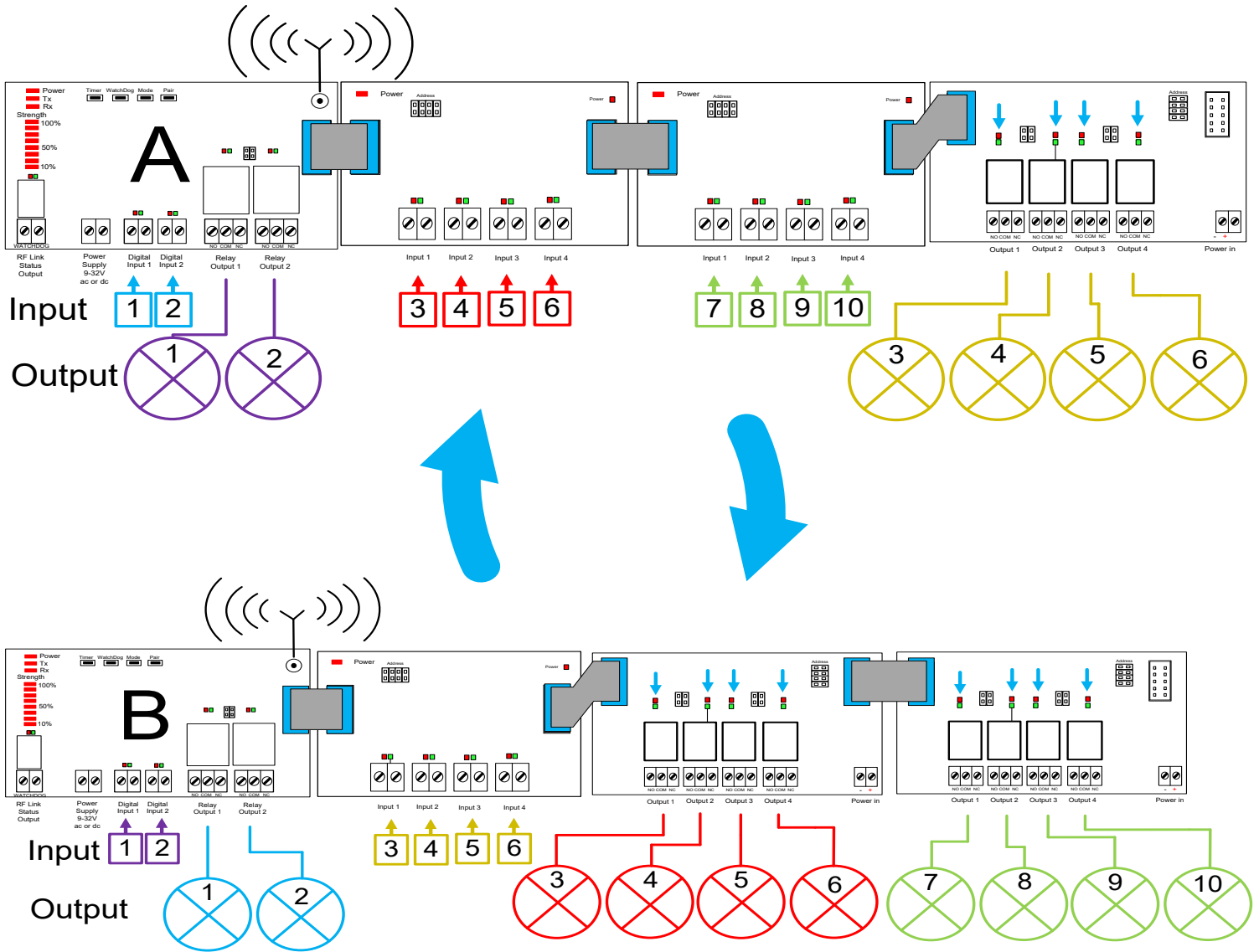

## More Advanced Example - using Multiple Transceiver Modules

### Application Example:

In the example below

'A' input 1 is paired with 'B' Output2

'A' input 2 is paired with 'C' output 1

'B' input 2 is paired with 'C' output 2

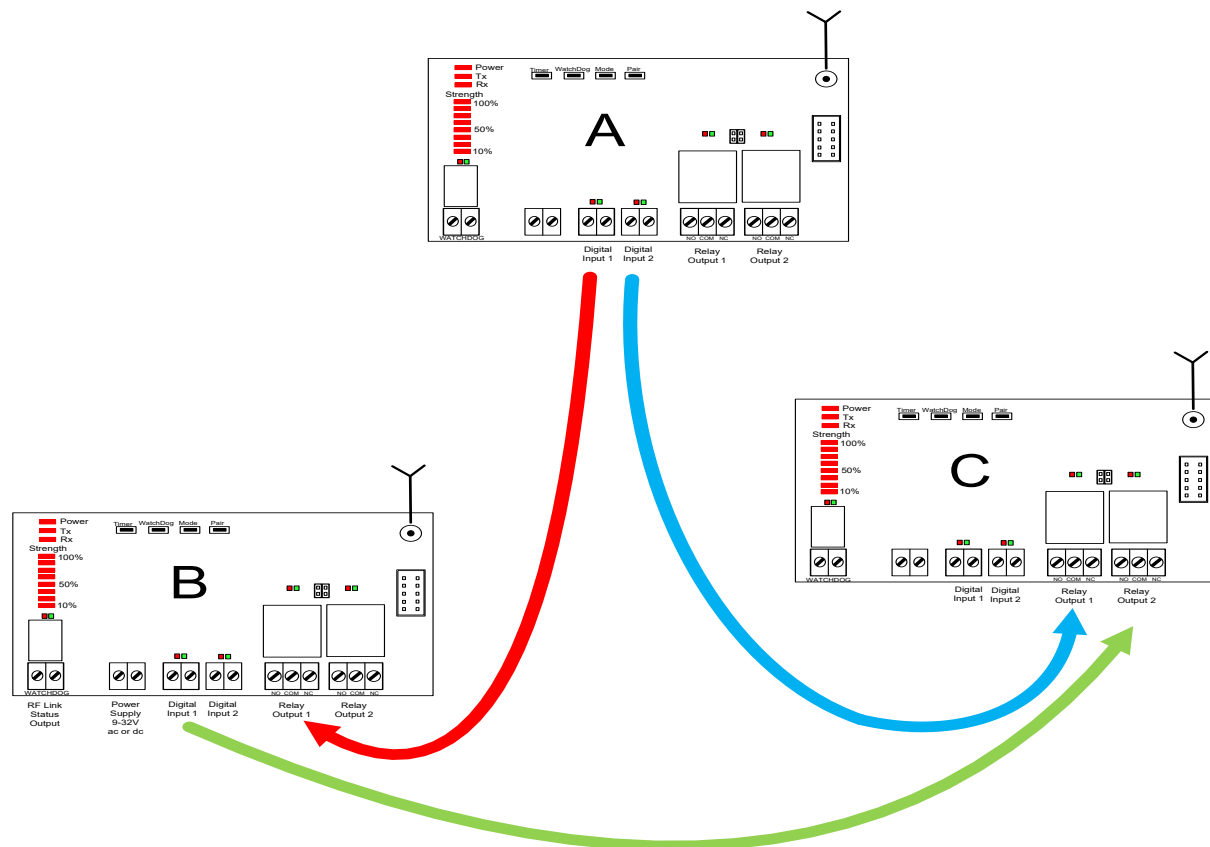

## Optional Component Parts / Spares

### ENC-DA3 enclosure:

- IP65 rated DIN rail enclosure
- 12V volt PSU
- 305mm X 220mm X 125mm
- Premade Back plate with DIN Rail Mount
- Easy clip fit for 700 series products



### 12V1A-IN-IP:

- IP67 rated PSU
- 12V volt
- 1Amp



### CBA-SMAMR-SMAF:

Used for externally mounting an antenna

- SMA Male Right Angle
- 2. SMA Female Bulkhead Straight



### ANT-GSM5WM:

- Wall mount antenna
- 3m cable
- Wall Mount Whip Antenna
- 824-960
- Active gain: +5dB
- RG58 Connecting Lead



# 725 Series



## Technical Specifications

### Transceiver: 725-TRX

Dimensions: 136 x 78 x 42 mm

Storage Temperature: -10 to +70° Celsius.

Operating Temperature: -10 to +50° Celsius.

Electrical Characteristics	Min	Typical	Max	Units	Note
Supply Voltage	12		32	Vdc or ac	1
Frequency:		869.500 915		MHz	
RF Output Power (ERP) @ 869.50 MHz	-	100		mW	
Supply Current : Quiescent		45		mA	2
All output relays operating		+101		mA	
Watchdog relay operating		+25		mA	
When transmitting		+95		mA	

### Input Module: 725-IP

Dimensions: 68 x 78 x 42 mm

Storage Temperature: -10 to +70° Celsius.

Operating Temperature: -10 to +50° Celsius.

Electrical Characteristics	Min	Typical	Max	Units	Note
Supply Voltage		N/A		V	1
Supply Current		15		mA	

### Output Module: 725-OP

Dimensions: 136 x 78 x 42 mm

Storage Temperature: -10 to +70° Celsius.

Operating Temperature: -10 to +50° Celsius.

ELECTRICAL CHARACTERISTICS	Mode	Min	Typical	Max	Units	Note
Supply Voltage		12	N/A	32	V	1
Relay Rating* (230Vac) RLY 1-4			5		A(rms)	2
Time delay from Tx on Switch to Rx Relay operation	FSK LORA		30 30- 1500		mS mS	
Time delay from Tx sw relax to Rx Relay re-release	FSK LORA		30 30- 1500		mS mS	
Supply Current : Quiescent		12			mA	
All relays operating		+90			mA	

### Output Module: 725-DOP8

Dimensions: 90 x 78 x 42 mm

Storage Temperature: -10 to +70° Celsius.

Operating Temperature: -10 to +50° Celsius.

Electrical Characteristics	Min	Typical	Max	Units	Note
Supply Voltage	0.1	N/A	30	V	3
Supply Current per channel operating		6	7	A	
Quiescent current				mA	

### Notes:

1. No direct power connection is required. The power is derived directly from 725-868 ribbon cable
2. The relay contacts in this unit are for functional use only and must not be used for isolation purposes
3. The supply input voltage is the output voltage for all outputs on the board.





## Important European compliance information

This RF Solutions product meets the essential requirements of the European Radio Equipment Directive 2014/53/EU and has been tested to European Harmonised Standards and CE marked accordingly. A copy of the EU Declaration of Conformity can be located on the RF Solutions Website, [www.rfsolutions.co.uk/certification-i59](http://www.rfsolutions.co.uk/certification-i59).

## RF Solutions Ltd. Recycling Notice

Meets the following EC Directives:

**DO NOT** Discard with normal waste, please recycle.

**ROHS Directive 2011/65/EU and amendment 2015/863/EU**

Specifies certain limits for hazardous substances.

**WEEE Directive 2012/19/EU**

Waste electrical & electronic equipment. This product must be disposed of through a licensed WEEE collection point. RF Solutions Ltd., fulfils its WEEE obligations by membership of an approved compliance scheme. Environment Agency Registration Number WEE/JB0104WV



R F Solutions Ltd.,  
William Way, Burgess Hill  
West Sussex. RH15 9AG England.

Email : [sales@rfsolutions.co.uk](mailto:sales@rfsolutions.co.uk) <http://www.rfsolutions.co.uk>

Tel Sales: 01444 227910

Tel Technical: 01444 227909

Whilst the information in this document is believed to be correct at the time of issue, RF Solutions Ltd does not accept any liability whatsoever for its accuracy, adequacy or completeness. No express or implied warranty or representation is given relating to the information contained in this document. RF Solutions Ltd reserves the right to make changes and improvements to the product(s) described herein without notice. Buyers and other users should determine for themselves the suitability of any such information or products for their own particular requirements or specification(s). RF Solutions Ltd shall not be liable for any loss or damage caused as a result of user's own determination of how to deploy or use RF Solutions Ltd's products. Use of RF Solutions Ltd products or components in life support and/or safety applications is not authorised except with express written approval. No licences are created, implicitly or otherwise, under any of RF Solutions Ltd's intellectual property rights. Liability for loss or damage resulting or caused by reliance on the information contained herein or from the use of the product (including liability resulting from negligence or where RF Solutions Ltd was aware of the possibility of such loss or damage arising) is excluded. This will not operate to limit or restrict RF Solutions Ltd's liability for death or personal injury resulting from its negligence.

## X-ON Electronics

Largest Supplier of Electrical and Electronic Components

*Click to view similar products for [RF Transceiver](#) category:*

*Click to view products by [RF Solutions](#) manufacturer:*

Other Similar products are found below :

[ADRV9026BBCZ](#) [ADRV9026-MB/PCBZ](#) [ADL6316ACCZ](#) [ADL6316ACCZ-R7](#) [ADL6317ACCZ](#) [SYN480R](#) [VI4455](#) [CC1260RGZT](#)  
[NRF51822-CEAA-R \(E0\)](#) [AT86RF232-ZX](#) [ADF7021-NBCPZ-RL](#) [ADRV9008BBCZ-2](#) [ADF7030-1BSTZN-RL](#) [AD9874ABSTRL](#)  
[ADF7020-1BCPZ-RL7](#) [ADF7020BCPZ](#) [ADF7020BCPZ-RL](#) [ADF7021BCPZ](#) [ADF7021BCPZ-RL](#) [ADF7021BCPZ-RL7](#) [ADF7021-NBCPZ](#)  
[ADF7021-VBCPZ](#) [ADF7023-JBCPZ](#) [ADF7025BCPZ](#) [ADF7241BCPZ](#) [ADRV9029BBCZ](#) [AT86RF231-ZU](#) [AT86RF232-ZXR](#) [AT86RF233-](#)  
[ZF](#) [AT86RF233-ZU](#) [ATA8520-GHQW](#) [BRAVO-T868](#) [SX1236IMLTRT](#) [HT9170D](#) [BGT 24MTR11 E6327](#) [BGT24MTR11E6327XUMA1](#)  
[BGT24MTR12E6327XUMA1](#) [MAX2510EEI+](#) [MAX2511EEI+](#) [MAX2510EEI+T](#) [MAX2832ETM+](#) [MAX7030LATJ+](#) [SX1212IWLTRT](#)  
[MAX9947ETE+](#) [AT86RF212B-ZU](#) [AT86RF231-ZUR](#) [ATA5429-PLSW](#) [NRF24LE1-O17Q32-R](#) [AT86RF233-ZUR](#) [MRF24J40-I/ML](#)