



A Division of Richardson Electronics

# PM 2112

## DATA SHEET

### Single Supply RFIC Power Amplifier 1880 to 1990 MHz Operation

#### Features

- 3 to 5 Volt Operation
- 28 dBm Output Power @ 3V
- 45% Efficiency
- Class A Bias
- Low IMD / ACP

#### Applications

- DECT
- PHS / PACS
- PCS-1900
- Upbanded IS-54 / IS-136

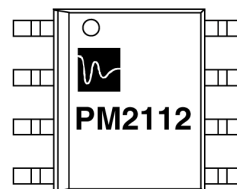

SO-8 Plastic Package

#### Description

The PM2112 is a 3 to 5 volt single supply, high efficiency GaAs RFIC power amplifier developed for commercial wireless products in the 1900 MHz frequency range. The PM2112 provides +28 dBm output power with efficiencies exceeding 45% at 3.0 volts and +30 dBm at 5.0 volts. Class A operation insures low distortion operation for linear applications.

#### Electrical Characteristics $V_{DD}=3.0V, T_A = +25^{\circ}C, 50 \Omega$ System

Characteristics	Symbol	Conditions	Min	Typ	Max	Units
Frequency Range	F		1880		1990	MHz
Input Return Loss	RL			10		dB
Small Signal Gain	G			27		dB
Power Output ( $P_{1dB}$ )	$P_{1dB}$	F=1900 MHz		26		dBm
Power Output (Saturated)	$P_{SAT}$	F=1900 MHz, $P_{in} = +5.0$ dBm	27	28		dBm
Third Order Intermodulation	IM3	$P_{OUT} = +26$ dBm		-19		dBc
Fifth Order Intermodulation	IM5	$P_{OUT} = +26$ dBm		-50		dBc
Power Added Efficiency	$P_{AE}$	F=1900 MHz, $P_{in} = +5.0$ dBm	40	45		%
Supply Current	$I_{DD}$			450		mA
Thermal Resistance	$\theta_{JC}$	T= 85°C, $P_{DISS} = 1.9W$		35		°C/W

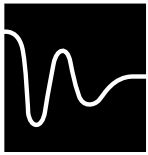

**Absolute Maximum Ratings\***

Characteristics	Symbol	Value	Units
DC Drain Voltage	V <sub>DD</sub>	+9.0	V
DC Drain Current	I <sub>DS</sub>	900	mA
Average Power Dissipation (P <sub>DISS</sub> = P <sub>DC</sub> - P <sub>RF</sub> )	P <sub>DISS</sub>	1.9	W
RF Input Power	P <sub>IN</sub>	15.0	dBm
Operating Baseplate Temperature	T <sub>OP</sub>	-40 to +85	°C
Junction Temperature	T <sub>J</sub>	150	°C
Storage Temperature Range	T <sub>STG</sub>	-65 to +150	°C

\*Operation beyond the ratings for any one of these parameters may cause permanent damage to the device

**Typical Performance Characteristics**

Test Conditions: T<sub>A</sub> = +25°C, V<sub>DD</sub> = 3.0V, F=1900 MHz, 50Ω system unless otherwise noted.

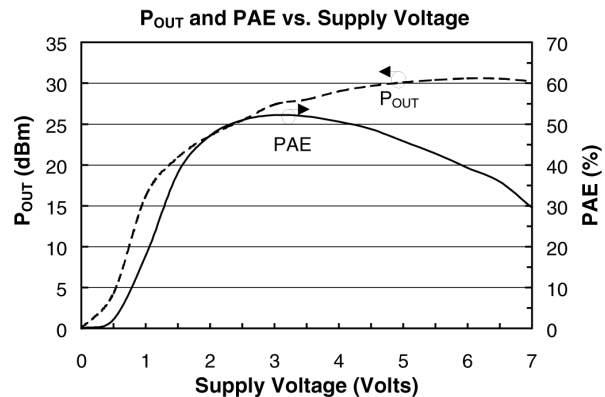
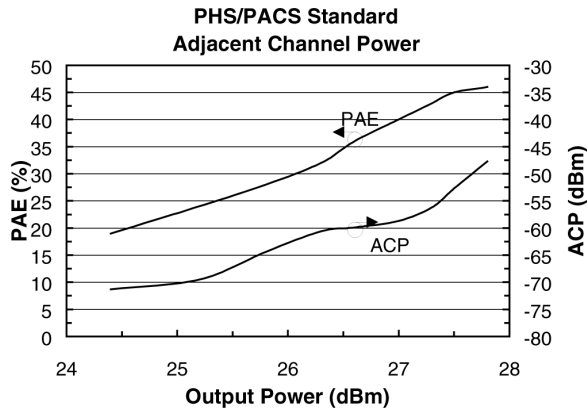
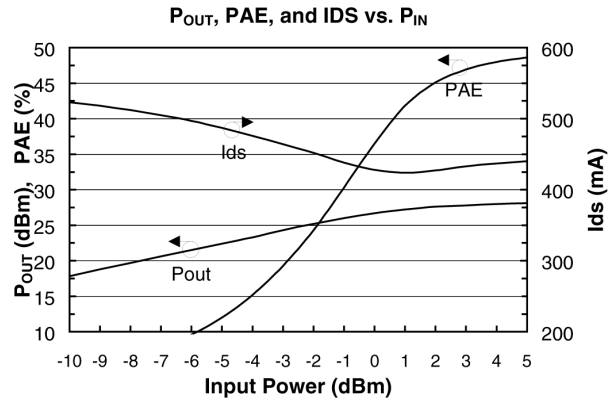
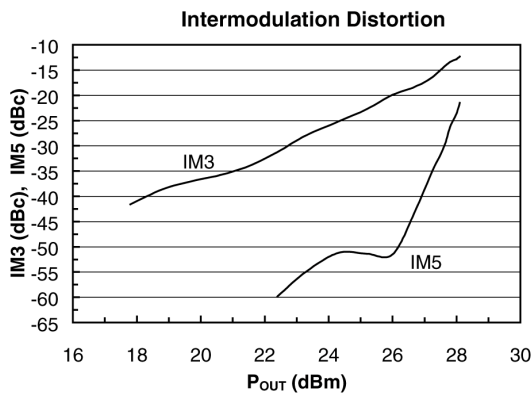

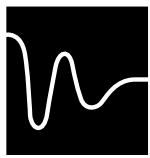

**PM2112 Typical Scattering Parameters,  $V_{DD}= 3.0V$ ,  $T_A= +25^{\circ}C$ ,  $50 \Omega$  System**

Freq. (MHz)	S <sub>11</sub>		S <sub>21</sub>		S <sub>12</sub>		S <sub>22</sub>		K Factor
	MAG	ANG	MAG	ANG	MAG	ANG	MAG	ANG	
500	0.917	-31.82	33.99	34.21	0.0005	82.63	0.277	-138.75	4.55
750	0.925	-44.49	30.86	-37.79	0.0009	168.42	0.709	-144.55	0.77
1000	0.921	-54.21	8.88	-94.96	0.0022	156.91	0.806	-167.62	1.22
1250	0.970	-68.65	4.83	-37.76	0.0033	158.34	0.745	-176.36	0.10
1500	0.976	-94.42	14.83	-53.09	0.0064	159.45	0.697	-174.98	-0.48
1750	0.653	-114.66	16.09	-110.08	0.0099	132.76	0.802	-178.78	0.34
1800	0.609	-114.71	14.97	-117.63	0.0096	129.17	0.808	179.11	0.54
1850	0.578	-115.12	14.19	-124.80	0.0104	122.76	0.812	178.01	0.64
1900	0.556	-115.62	13.32	-131.55	0.0099	119.04	0.816	175.79	0.80
1950	0.542	-115.67	12.30	-136.92	0.0103	121.23	0.809	173.92	0.90
2000	0.533	-116.19	11.49	-141.17	0.0096	114.54	0.806	172.40	1.14
2250	0.507	-123.66	8.70	-160.85	0.0115	111.83	0.802	166.46	1.39
2500	0.493	-135.57	6.77	-176.78	0.0129	102.51	0.783	160.20	1.78
2750	0.490	-148.03	5.35	170.89	0.0132	94.63	0.761	156.61	2.39
3000	0.495	-161.10	4.46	160.35	0.0141	90.41	0.761	153.27	2.62
3250	0.515	-172.51	3.69	148.95	0.0146	83.03	0.753	148.96	3.07
3500	0.538	176.34	3.05	140.22	0.0143	72.79	0.740	146.20	3.85
3750	0.566	170.08	2.62	133.23	0.0146	72.03	0.750	144.32	4.05
4000	0.591	164.39	2.30	125.04	0.0153	66.08	0.747	140.72	4.28
4250	0.619	160.57	1.97	118.20	0.0153	66.41	0.744	138.04	4.77
4500	0.640	157.56	1.77	113.29	0.0160	60.77	0.735	135.84	5.05
4750	0.652	155.42	1.62	106.33	0.0166	58.37	0.746	131.18	5.03
5000	0.657	154.50	1.45	98.98	0.0184	53.99	0.730	126.82	5.28
5250	0.655	153.22	1.31	94.34	0.0195	49.24	0.721	122.84	5.69
5500	0.650	152.83	1.25	88.41	0.0223	42.01	0.723	117.70	5.32
5750	0.643	152.88	1.16	80.66	0.0207	27.77	0.714	111.21	6.41
6000	0.644	150.69	1.06	74.84	0.0199	33.18	0.705	105.60	7.36

**S-Parameter Measurement Setup:**

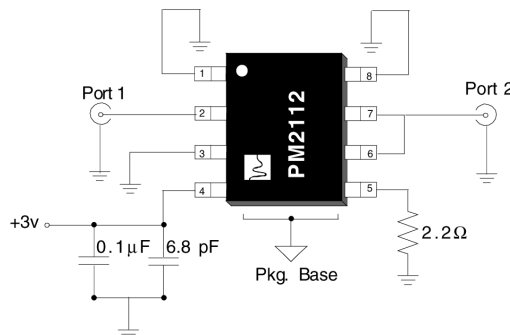

**Note:**  $V_{DD2}$  and GND return for  $V_{GG1}$  are supplied through bias tee.

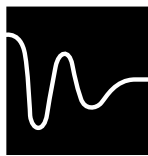

## Package Specifications

### Pin Connections

Pin #	Function
1	GND
2	RF <sub>IN</sub>
3	GND
4	V <sub>DD1</sub>
5	V <sub>GG2</sub>
6, 7	RF <sub>OUT</sub> / V <sub>DD2</sub>
8	GND
Base	GND

### SO-8 Outline Drawing

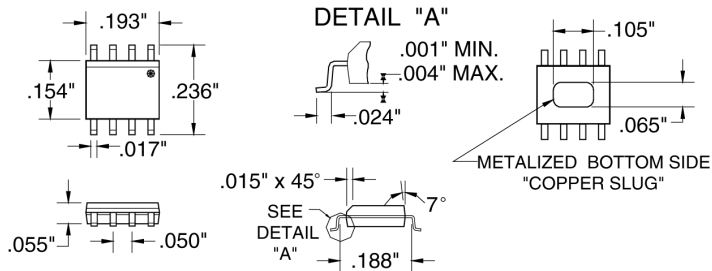

### Typical Matching Network for the PM2112 at 1880-1990 MHz

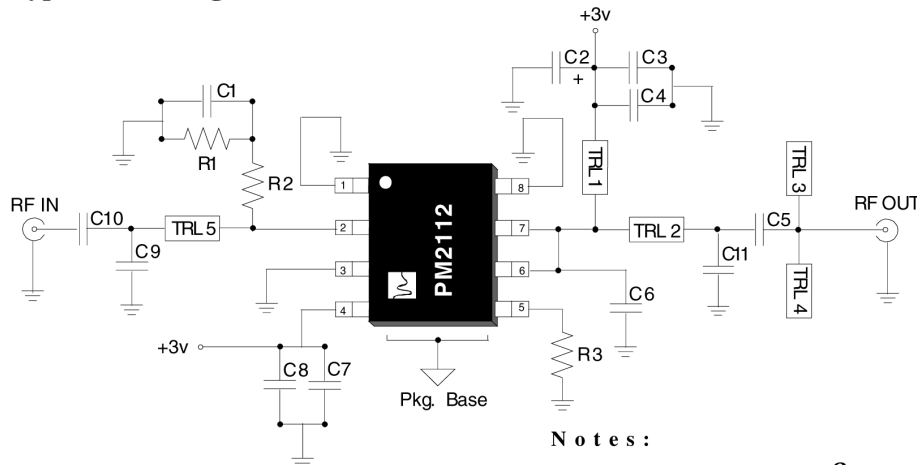

**Notes:**  
PCB Material: 0.028" FR4,  $\epsilon_r = 4.2$

### List of Components

Part	Value	Size
C1, C4	33 pF	0603
C10	33 pF	0603
C2	6.8 $\mu$ F	1238
C3, C7	1000 pF	0603
C5	6.8 pF	0603
C6	3.0 pF	0603
C8	0.1 $\mu$ F	0603
C9	1.5 pF	0603
C11	1.0 pF	0603
R1	51 $\Omega$	0603
R2	5.6 $\Omega$	0603
R3	2.2 $\Omega$	0603

### Technical Information

The area beneath the amplifier and the associated matching networks must have a continuous ground plane or the resulting performance of the amplifier may be degraded. Terminate pins 1, 3, 8 and package base to a common ground pad. This ground pad must provide a connection to the back side of the ground plane with plated via holes. It is important to provide a good thermal path for the PM2112 since the device can dissipate up to 1.9 Watts of continuous average power.

The PM2112 requires external input and output matching for proper operation. Input match is accomplished using C9 and TRL5. R1, R2, and C1 provide added stability. The output match consists of C5, C6, TRL1, and TRL2. Harmonic termination is improved by TRL3 and TRL4. Interstage matching is on-chip with R3 added to improve inband stability. Extensive bypassing is recommended for linear digitally modulated applications requiring good IMD performance. The TRL values at 1900 MHz are as follows;

- TRL1:** W=.015 L=.450 ( $Z=90\Omega$ ,  $\theta=44^\circ$ )      **TRL3,4:** W=.050 L=.175 ( $Z=50\Omega$ ,  $\theta=18^\circ$ )  
**TRL2:** W=.050 L=.225 ( $Z=50\Omega$ ,  $\theta=23^\circ$ )      **TRL5:** W=.050 L=.170 ( $Z=50\Omega$ ,  $\theta=17^\circ$ )

## X-ON Electronics

Largest Supplier of Electrical and Electronic Components

*Click to view similar products for [RF Amplifier](#) category:*

*Click to view products by [Richardson](#) manufacturer:*

Other Similar products are found below :

[ADPA7006AEHZ](#) [CXE2089ZSR](#) [MGA-43828-BLKG](#) [A82-1](#) [RF2878TR7](#) [BGA 728L7 E6327](#) [BGB719N7ESDE6327XTMA1](#) [HMC1126-SX](#) [HMC342](#) [HMC561-SX](#) [HMC598-SX](#) [HMC-ALH382-SX](#) [HMC-ALH476-SX](#) [SE2433T-R](#) [SE2622L-R](#) [SMA3101-TL-E](#) [SMA39](#) [SMA70-1](#) [A66-1](#) [A66-3](#) [A67-1](#) [LX5535LQ](#) [LX5540LL](#) [RF2373TR7](#) [HMC3653LP3BETR](#) [HMC395](#) [HMC549MS8GETR](#) [HMC576-SX](#) [HMC754S8GETR](#) [HMC-ALH435-SX](#) [SMA101](#) [SMA1031](#) [SMA181](#) [SMA32](#) [SMA411](#) [SMA531](#) [SST12LP17E-XX8E](#) [SST12LP19E-QX6E](#) [TGA2598](#) [WPM0510A](#) [HMC5929LS6TR](#) [HMC5879LS7TR](#) [HMC906A-SX](#) [HMC1127](#) [HMC544A](#) [HMC1126](#) [HMC1110-SX](#) [HMC1087F10](#) [HMC1086](#) [HMC1016](#)