

USB PD Port and Power Controller

General Description

The RT1711P is a USB Type-C and Power Delivery (PD) controller, which complies with the latest USB Type-C and PD standards. The RT1711P integrates a complete Type-C transceiver including the Type-C termination resistors, Rp and Rd, and enables the USB Type-C detection including attach and orientation. It also integrates the physical layer of the USB BMC power delivery protocol, allowing power transfers of up to 100W and role swap. The BMC PD function provides full support for Alternate Modes on the USB Type-C standard. The RT1711P provides a complete power management solution, which consists of one barrel jack path and one VBUS path for charging systems. Another provider path provides a seamless voltage transition and avoids the discontinuity of voltage transition during USB PD power contracts.

Applications

- Tablets
- Laptops
- Notebooks
- Monitors
- Power Banks
- TVs

Pin Configuration

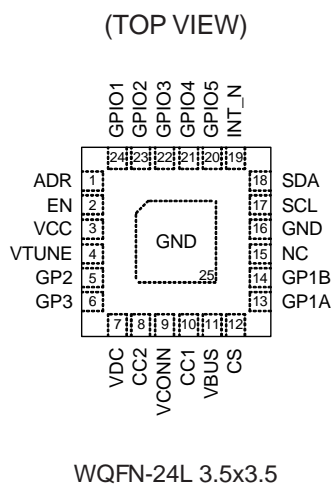

Features

- **PD-Compatible Dual-Role**
- **Support USB PD3.0 and TCPC1.0**
- **Full Power Path Control**
 - ▶ **Barrel Jack Path : Up to 20V (N-MOSFET)**
 - ▶ **PD Provider & Consumer Path Up to 20V (N-MOSFET)**
- **Protection**
 - ▶ **VBUS Provider Path with Programmable Over-Current Protection (OCP) and Over-Voltage Protection (OVP)**
 - ▶ **VBUS Path with Aided Discharge**
 - ▶ **VCONN with Programmable Current Limit**
 - ▶ **VCONN with OVP Protection and Discharge**
 - ▶ **CC Pin 20V Short-VBUS Circuit Protection**
- **Adjustable DC-DC Output Voltages**
- **Current Capability Definition and Detection**
- **Cable Recognition and Alternate Modes Support**
- **Dead Battery and No Battery Support**
- **Low-Power Mode for Attach Detection**
- **BIST Mode Supported**
- **Support GPIO**
- **24-Lead WQFN Package**

Ordering Information

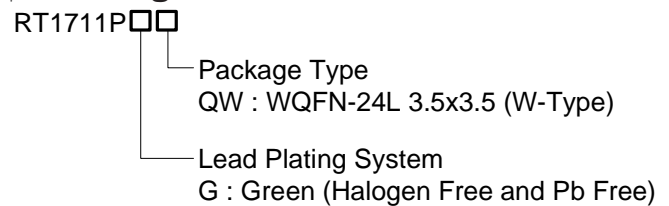

Note :

Richtek products are :

- ▶ RoHS compliant and compatible with the current requirements of IPC/JEDEC J-STD-020.
- ▶ Suitable for use in SnPb or Pb-free soldering processes.

Marking Information

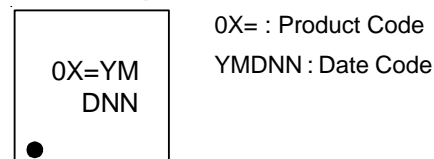

Typical Application Circuit

Provider/Consumer

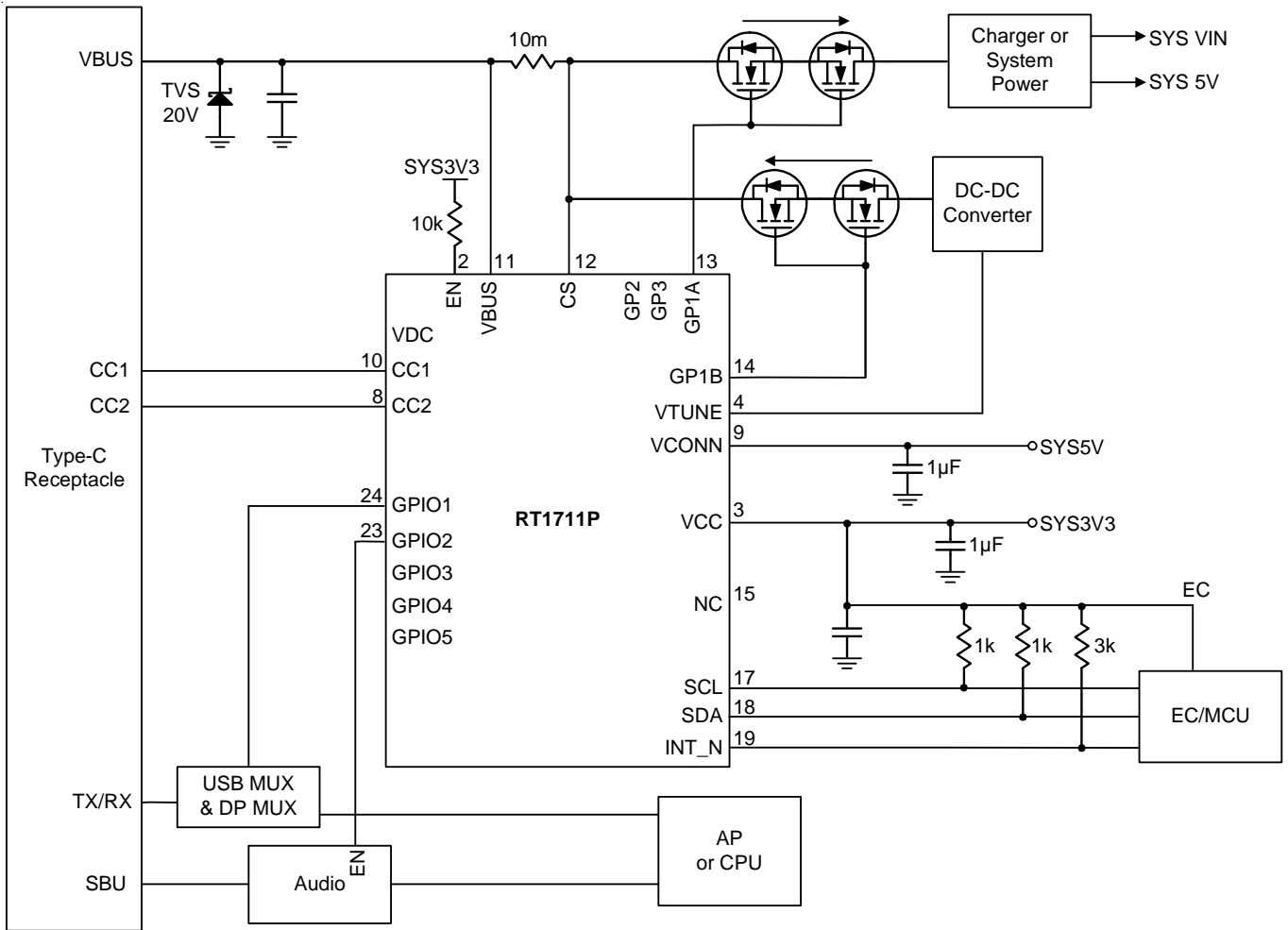

Note : SYS3V3 is connected to a PMIC and is supplied by the PMIC.

1. DC-DC converter recommend best solution. The following table can pass USB PD compliance test.
2. The RT8131B is a high efficiency single phase synchronous buck DC-DC controller. Please refer to the RT8131B datasheet.
3. The RT8525D is a wide input operating voltage range step up controller. High voltage output and large output current are feasible by using an external N-MOSFET. Please refer to the RT8525D datasheet.

VIN	Watts	VOUT/IOUT	Item
12V to 20V	45W	5V, 9V, 12V, 15V/20V	RT8525D (Boost IC)
		3A, 3A, 3A, 3A, 2.25A	RT8131B (Buck IC)
18V to 20V	65W	5V, 9V, 12V, 15V/20V	RT8525D (Boost IC)
		3A, 3A, 3A, 3A, 3.25A	RT8131B (Buck IC)
24V	45W/65W/100W	5V, 9V, 12V, 15V, 20V	RT8131B (Buck IC)
		3A, 3A, 3A, 3A/5A, 3A/5A	

Provider

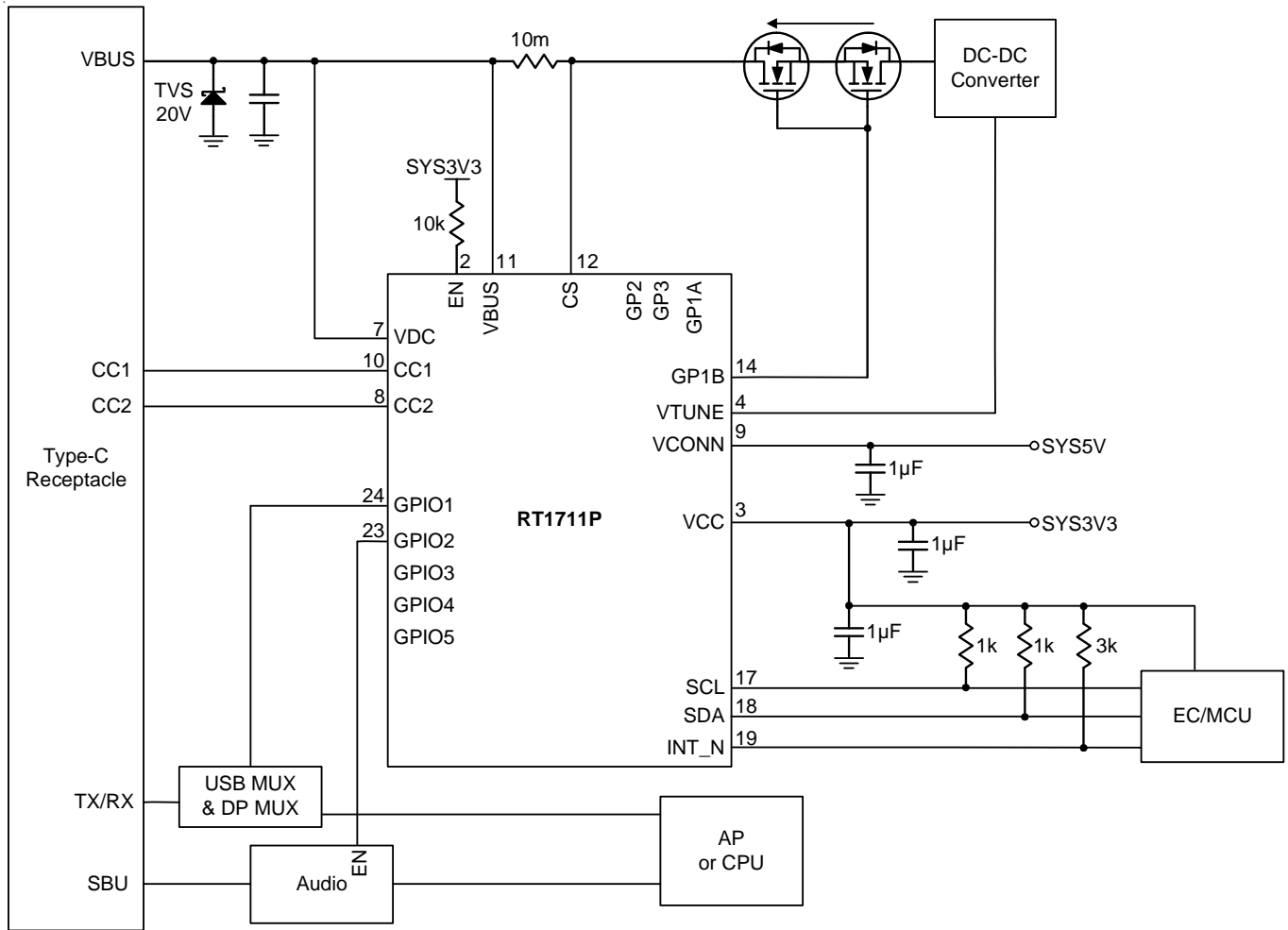

Note : SYS3V3 is connected to a PMIC and is supplied by the PMIC.

1. DC-DC converter recommend best solution. The following table can pass USB PD compliance test.
2. The RT8131B is a high efficiency single phase synchronous buck DC-DC controller. Please refer to the RT8131B datasheet.
3. The RT8525D is a wide input operating voltage range step up controller. High voltage output and large output current are feasible by using an external N-MOSFET. Please refer to the RT8525D datasheet.

VIN	Watts	VOUT/IOUT	Item
12V to 20V	45W	5V, 9V, 12V, 15V/20V	RT8525D (Boost IC)
		3A, 3A, 3A, 3A, 2.25A	RT8131B (Buck IC)
18V to 20V	65W	5V, 9V, 12V, 15V/20V	RT8525D (Boost IC)
		3A, 3A, 3A, 3A, 3.25A	RT8131B (Buck IC)
24V	45W/65W/100W	5V, 9V, 12V, 15V, 20V	RT8131B (Buck IC)
		3A, 3A, 3A, 3A/5A, 3A/5A	

Consumer

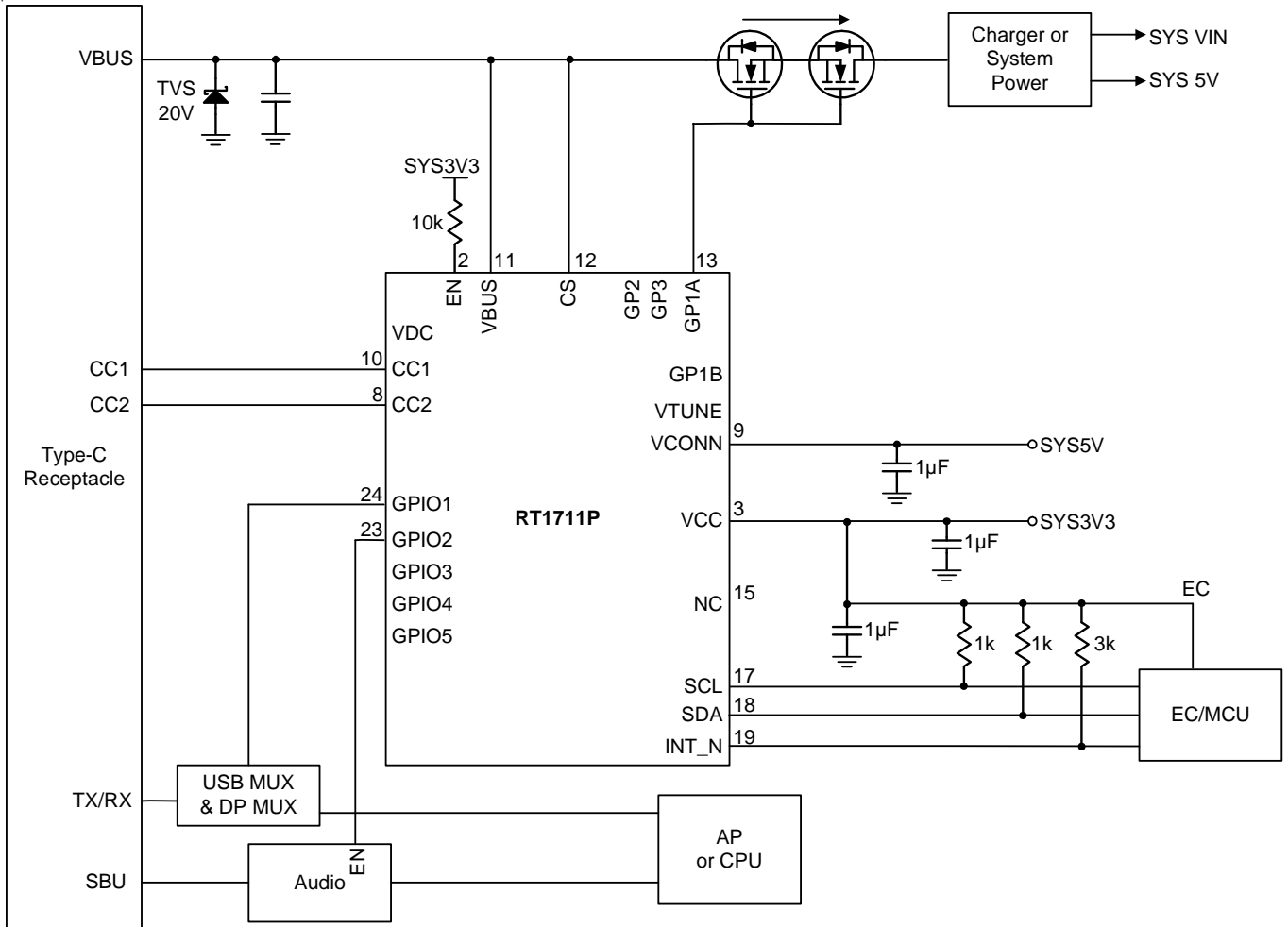

Note : SYS3V3 is connected to a PMIC and is supplied by the PMIC.

Functional Pin Description

Pin No.	Pin Name	Pin Function
1	ADR	Address selection node when used with multiple type-C ports.
2	EN	External power path control input, active-high.
3	VCC	Input supply voltage.
4	VTUNE	Connected to FB pin of a DC-DC converter to adjust DC-DC output voltages.
5	GP2	High voltage open-drain gate driver, which may be used to drive an NMOS/PMOS power switch. This pin is connected to the gate of the power switch. (Related to VDC).
6	GP3	High voltage open-drain gate driver, which may be used to drive an NMOS/PMOS power switch. This pin is connected to the gate of the power switch. (Related to VDC).
7	VDC	Barrel jack or wireless charger DC power input pin for charging path control.
8	CC2	Type-C connector Configuration Channel (CC) 2, used to detect a cable plug event and determine the cable orientation.
9	VCONN	Regulated input voltage to power CCx pins as VCONN.
10	CC1	Type-C connector Configuration Channel (CC) 1, used to detect a cable plug event and determine the cable orientation.
11	VBUS	VBUS input using for OCP/OVP detection and as a power source for VBUS path control.
12	CS	Current sense input.
13	GP1A	High voltage open-drain gate driver, which may be used to drive an NMOS/PMOS power switch. This pin is connected to the gate of the power switch. (Related to VBUS).
14	GP1B	High voltage open-drain gate driver, which may be used to drive an NMOS/PMOS power switch. This pin is connected to the gate of the power switch. (Related to VBUS).
15	NC	No internal connection.
16, 25 (Exposed Pad)	GND	Ground. The exposed pad must be connected to GND and well soldered to a large copper PCB and for maximum power dissipation.
17	SCL	I ² C interface serial clock input. Open-drain. An external pull-up resistor is required.
18	SDA	I ² C serial data input/output. Open-drain. An external pull-up resistor is required.
19	INT_N	Interrupt output, active-low open-drain, to prompt the processor to read the registers.
20	GPIO5	Configurable GPIO with open-drain or push-pull type, used as switch control, DC-DC enable, audio enable, and accessory unit control.
21	GPIO4	Configurable GPIO with open-drain or push-pull type, used as switch control, DC-DC enable, audio enable, and accessory unit control.
22	GPIO3	Configurable GPIO with open-drain or push-pull type, used as switch control, DC-DC enable, audio enable, and accessory unit control.
23	GPIO2	Configurable GPIO with open-drain or push-pull type, used as switch control, DC-DC enable, audio enable, and accessory unit control.
24	GPIO1	Configurable GPIO with open-drain or push-pull type, used as switch control, DC-DC enable, audio enable, and accessory unit control.

Functional Block Diagram

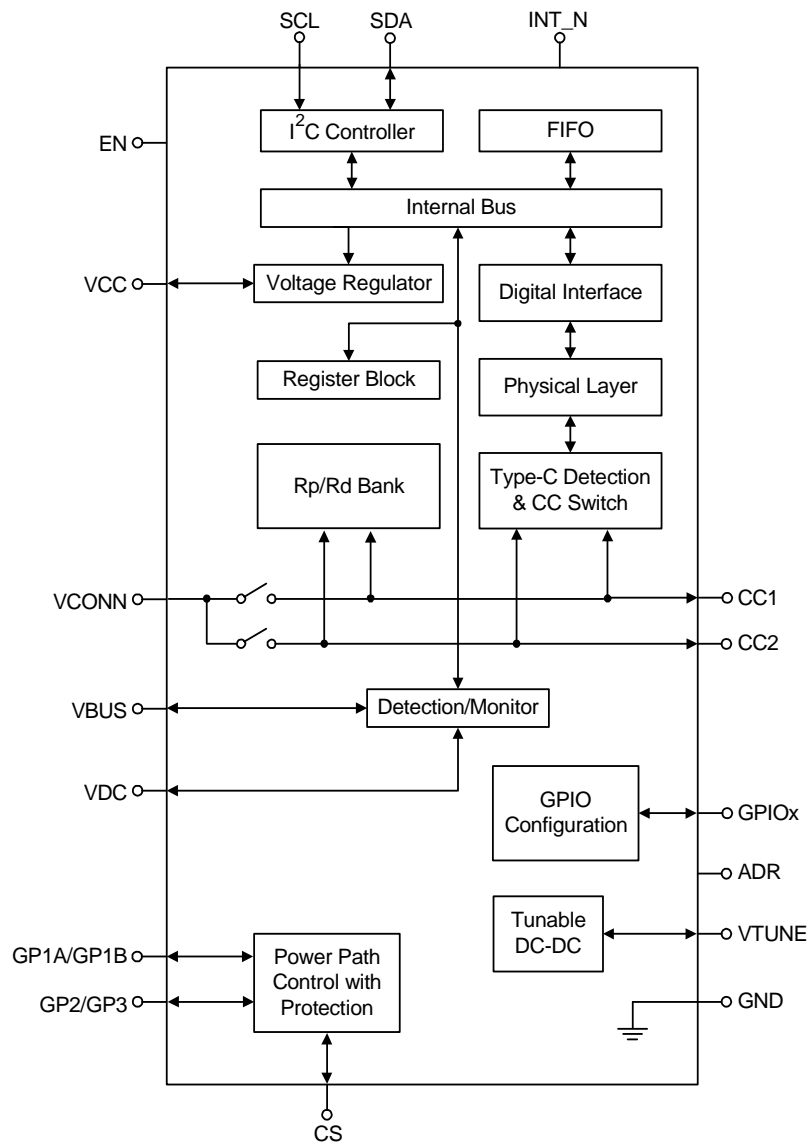

Absolute Maximum Ratings (Note 1)

- VCC/VCONN ----- -0.3V to 6V
- CC1/CC2 (Testing condition: VCC ≥ 3V) ----- -0.3V to 24V
- CC1/CC2 (Testing condition: VCC < 3V) ----- -0.3V to 6V
- VBUS/VDC ----- - 0.3V to 24V
- Power Dissipation, P_D @ T_A = 25°C
 WQFN-24L 3.5x3.5 ----- 3.5W
- Package Thermal Resistance (Note 2)
 WQFN-24L 3.5x3.5, θ_{JA} ----- 28.5°C/W
 WQFN-24L 3.5x3.5, θ_{JC} ----- 7°C/W
- Lead Temperature (Soldering, 10 sec.) ----- 260°C
- Junction Temperature ----- 150°C
- Storage Temperature Range ----- -65°C to 150°C
- ESD Susceptibility (Note 3)
 HBM (Human Body Model) ----- 2kV

Recommended Operating Conditions (Note 4)

- Supply Input Voltage ----- 3V to 5.5V
- VBUS/VDC ----- 4V to 22V
- VCONN Supply Current ----- 200 to 400mA
- VCONN Supply Voltage ----- 4.75V to 5.5V
- Junction Temperature Range ----- -40°C to 125°C
- Ambient Temperature Range ----- -40°C to 85°C

Electrical Characteristics

(V_{CC} = 3.3V, T_A = 25°C, unless otherwise specified.)

Parameter	Symbol	Test Conditions	Min	Typ	Max	Unit
Common Normative Signaling Requirements						
Bit Rate	f _{BITRATE}		270	300	330	Kbps
Common Normative Signaling Requirements for Transmitter						
Maximum difference between the bit-rate during the part of the packet following the Preamble and the reference bit-rate.	ρ _{BitRate}		--	--	0.25	%
Time from the end of last bit of a Frame until the start of the first bit of the next Preamble.	t _{InterFrameGap}		25	--	--	μs
Time before the start of the first bit of the Preamble when the transmitter shall start driving the line.	t _{StartDrive}		-1	--	1	μs

Parameter	Symbol	Test Conditions	Min	Typ	Max	Unit
BMC Common Normative Requirements						
Time to cease driving the line after the end of the last bit of the Frame.	t _{EndDriveBMC}		--	--	23	μs
Fall Time	t _F		300	--	--	ns
Time to cease driving the line after the final high-to-low transition	t _{HoldLowBMC}		1	--	--	μs
Rise Time	t _R		300	--	--	ns
Voltage Swing	V _{SWING}		1.05	1.125	1.2	V
Transmitter Output Impedance	Z _{DRIVER}		33	--	75	Ω
BMC Receiver Normative Requirements						
Time Window for Detecting Non-Idle	t _{TransitionWindow}		12	--	20	μs
Receiver Input Impedance	Z _{BMC RX}		1	--	--	MΩ
Power Consumption						
Disable Mode Current	I _{DM}	VCONN supply on power on state, I ² C pull low and no transaction	--	25	--	μA
		VCONN supply off power on state, I ² C pull low and no transaction	--	15	--	
Idle Mode Current (As a source)	I _{SBID1}	Cable attached with Ra, Rd	--	360	--	μA
		Cable attached with Rd		290		
Idle Mode Current (As a sink)	I _{SBID2}	Cable attached	--	180	--	μA
Low-Power Mode	I _{UL}	Cable unattached VCONN supply on, DRP toggle	--	V _{CC} = 35	--	μA
			--	V _{CONN} = 20	--	
		Cable unattached VCONN supply off, DRP toggle.	--	V _{CC} = 25	--	
Type-C Port Control						
VCONN Switch On-Resistance	R _{ON_VCONN}		--	--	1	Ω
VCONN OCP Range	I _{OCP_VCONN}		200	--	600	mA
VCONN Switched-On Time	t _{SOFT_VCONN}		--	1.2	--	ms
DFP 80μA CC Current	I _{CC_DFP80μ}		64	80	96	μA
DFP 180μA CC Current	I _{CC_DFP180μ}		166	180	194	μA
DFP 330μA CC Current	I _{CC_DFP330μ}		304	330	356	μA
UFP Pull-Down Resistance through Each CC Pin	R _d		4.59	5.1	5.61	kΩ

Parameter	Symbol	Test Conditions	Min	Typ	Max	Unit
UFP Pull-Down Threshold Voltage in Dead Battery	V _{TH_DBL}	Under I _{CC} = I _{CC_DFP80μ} and I _{CC_DFP180μ}	0.2	--	1.6	V
UFP Pull-Down Threshold Voltage in Dead Battery	V _{TH_DBH}	Under I _{CC} = I _{CC_DFP330μ}	0.8	--	2.6	V
VCC/VDC/EN Operation Conditions						
VCC Input Supply Voltage	V _{VCC}		3.0	3.3	5.5	V
VDC Input Supply Voltage	V _{VDC}		4.5	--	20	V
EN Threshold			0.8	1	1.2	V
VBUS Related Parameters						
VBUS Detection Valid Voltage (Rising)		Rising	--	4	--	V
VBUS Detection Invalid Voltage (Falling)		Falling	--	3.5	--	V
VBUS Vsafe0V			--	--	0.8	V
VBUS Measure Range			4	--	20	V
VBUS Measurement Resolution			--	50	--	mV
VBUS Measurement Update Interval			--	5.375	--	ms
VBUS Over-Voltage Protection Threshold Range	V _{TH_VBUSOVP}		5.5	--	23	V
VBUS Over-Current Protection Threshold Range	I _{TH_VBUSOCP}		0.6	--	6	A
VBUS OCP Deglitch Time	t _{D_VBUSOCP}		--	--	200	μs
VBUS Tuning Resolution (Source Side)			--	100	--	mV
I²C Electrical Characteristics						
I ² C Bus Supply Voltage	V _{CC_I2C}		1.5	--	3.6	V
Logic-Low Threshold Voltage for Inputs	V _{IL_I2C}		--	--	0.4	V
Logic-High Threshold Voltage for Inputs	V _{IH_I2C}		1.3	--	--	V
Logic-Low Threshold Voltage for Open-Drain Outputs	V _{OL_I2C}	Open-drain	--	--	0.4	V
Input Current for Each I/O Pin	I _{IN_IO_I2C}	0.1 * V _{CC} < V _{IN_IO} < 0.9 * V _{CC} (Max)	-10	--	10	μA
SCL Clock Frequency	f _{SCL}		0	--	1000	kHz
Maximum Spike Pulse width	t _{W_MAX_SP}		--	--	50	ns
Data Hold Time	t _{DH}		30	--	--	ns
Data Set-Up Time	t _{DS}		70	--	--	ns

Parameter	Symbol	Test Conditions	Min	Typ	Max	Unit
GPIO1 to GPIO5 Electrical Characteristics						
Logic-Low Threshold Voltage for Inputs	V _{IL_GPIO}		--	--	0.4	V
Logic-High Threshold Voltage for Inputs	V _{IH_GPIO}		1.1	--	--	V
Logic-Low Threshold Voltage for Outputs	V _{OL_GPIO}	I _{OL} = 4mA	--	--	0.4	V
Logic-High Threshold Voltage for Outputs	V _{OH_GPIO}	I _{OH} = -4mA	V _{CC} - 0.7V	--	--	V

(V_{CC} = 3.3V, V_{VCONN} = 5V, V_{BUS} = 20V, T_A = 25°C, unless otherwise specified.)

Parameter	Symbol	Test Conditions	Min	Typ	Max	Unit
N-MOSFET Gate Control Related Parameters						
GP1A/GP1B		For N-MOSFET gate control	V _{BUS} + V _{VCONN} - 1	V _{BUS} + V _{VCONN} - 0.7	V _{BUS} + V _{VCONN} - 0.2	V
GP2/GP3		For N-MOSFET gate control	V _{VDC} + V _{VCONN} - 1	V _{VDC} + V _{VCONN} - 0.7	V _{VDC} + V _{VCONN} - 0.2	V

Note 1. Stresses beyond those listed “Absolute Maximum Ratings” may cause permanent damage to the device. These are stress ratings only, and functional operation of the device at these or any other conditions beyond those indicated in the operational sections of the specifications is not implied. Exposure to absolute maximum rating conditions may affect device reliability.

Note 2. θ_{JA} is measured under natural convection (still air) at T_A = 25°C with the component mounted on a high effective-thermal-conductivity four-layer test board on a JEDEC 51-7 thermal measurement standard. θ_{JC} is measured at the exposed pad of the package.

Note 3. Devices are ESD sensitive. Handling precaution is recommended.

Note 4. The device is not guaranteed to function outside its operating conditions.

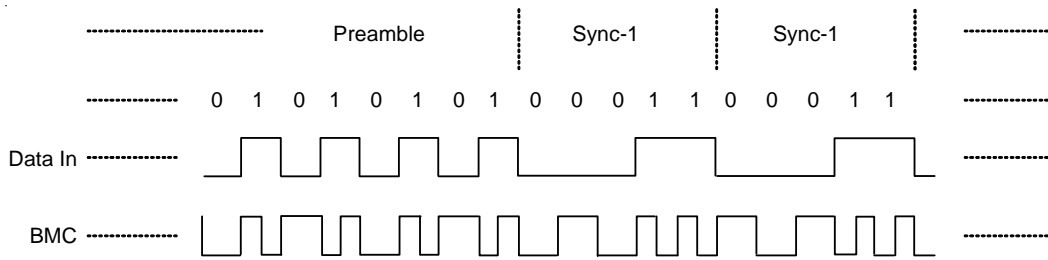

BMC Example

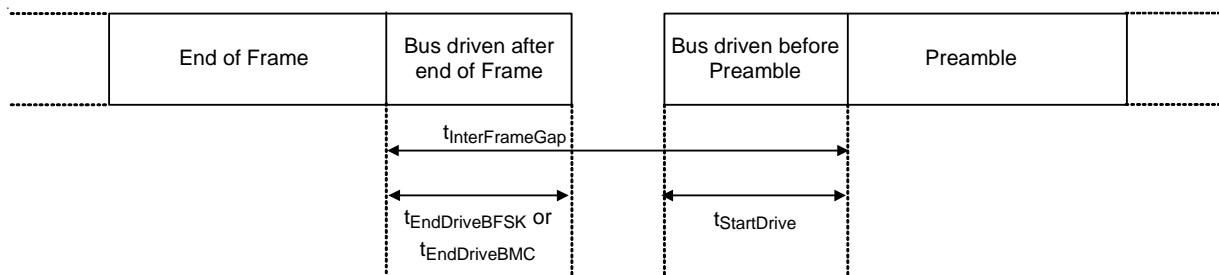

Inter-Frame Gap Timings

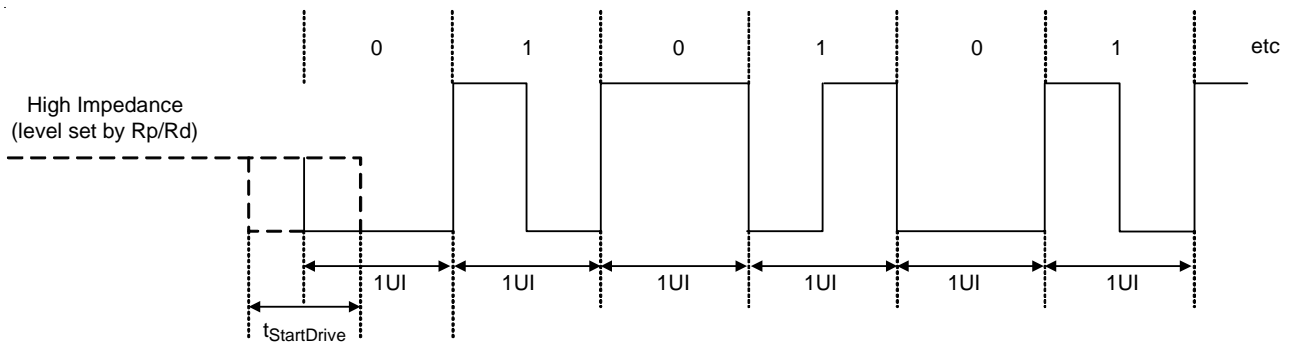

BMC Encoded Start of Preamble

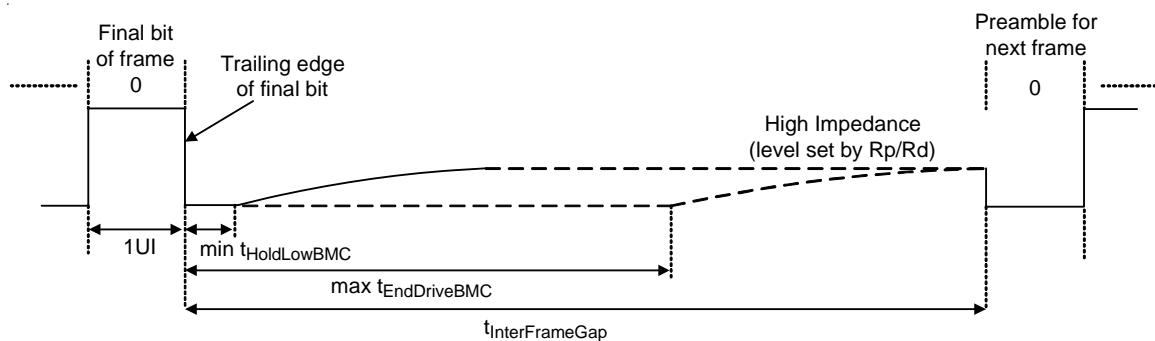

Transmitting or Receiving BMC Encoded Frame Terminated

BMC TC Mask Definition, X Values						
Parameter	Symbol	Test Conditions	Min	Typ	Max	Units
Left Edge of Mask	X1Tx			0.015		UI
X2Tx point	X2Tx			0.07		UI
X3Tx point	X3Tx			0.15		UI
X4Tx point	X4Tx			0.25		UI
X5Tx point	X5Tx			0.35		UI
X6Tx point	X6Tx			0.43		UI
X7Tx point	X7Tx			0.485		UI
X8Tx point	X8Tx			0.515		UI
X9Tx point	X9Tx			0.57		UI
X10Tx point	X10Tx			0.65		UI
X11Tx point	X11Tx			0.75		UI
X12Tx point	X12Tx			0.85		UI
X13Tx point	X13Tx			0.93		UI
Right Edge of Mask	X14Tx			0.985		UI

BMC TC Mask Definition, Y Values						
Parameter	Symbol	Test Conditions	Min	Typ	Max	Units
Lower bound of outer mask	Y1Tx			-0.075		V
Lower bound of inner mask	Y2Tx			0.075		V
Y3Tx point	Y3Tx			0.15		V
Y4Tx point	Y4Tx			0.325		V
Inner mask vertical midpoint	Y5Tx			0.5625		V
Y6Tx point	Y6Tx			0.8		V
Y7Tx point	Y7Tx			0.975		V
Y8Tx point	Y8Tx			1.04		V
Upper bound of outer mask	Y9Tx			1.2		V

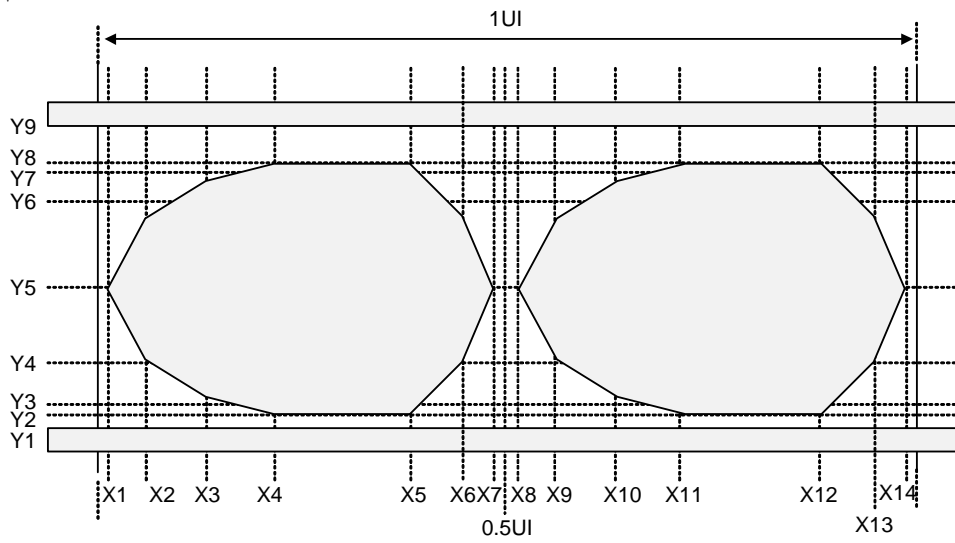

BMC T_X "ONE" Mask

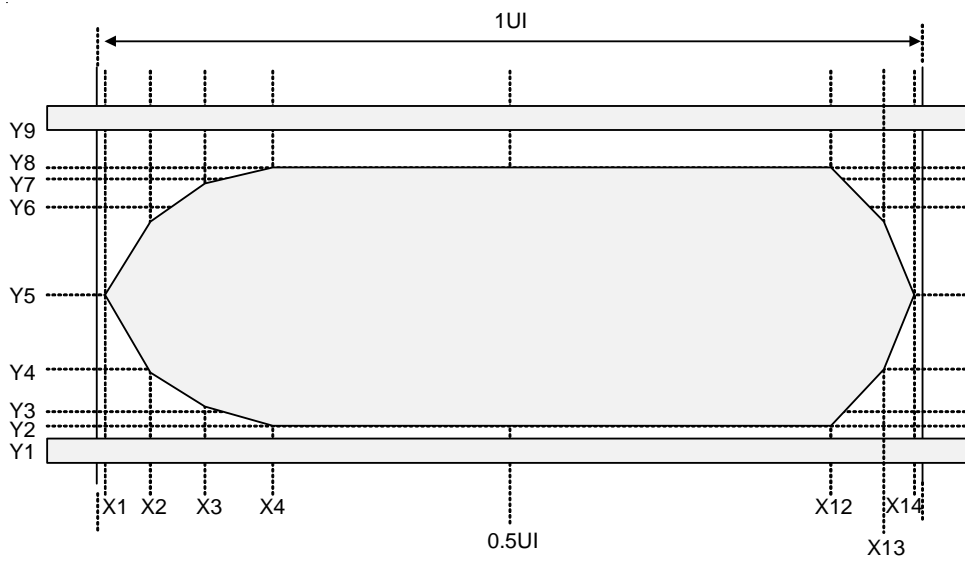

BMC T_X "ZERO" Mask

Application Information

Output Voltage Setting for the DC-DC Converter

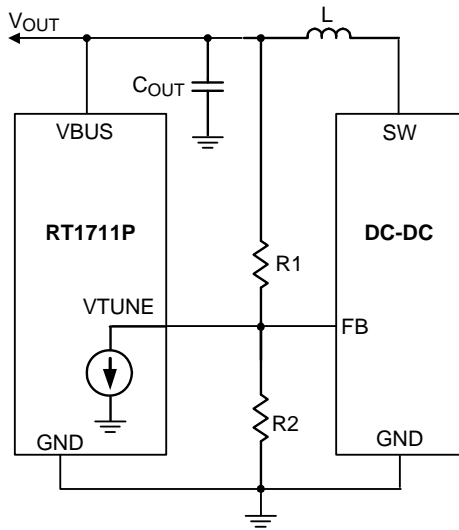

Figure 1

Figure 1 shows the RT1711P can change the output voltage (V_{OUT}) of the DC-DC converter by controlling the VTUNE sinking current.

The following table shows the range of R1 value :

V_{REF} of DC-DC	R1 Range (Ω)
0.6V	60k to 80k
0.8V	60k to 80k
1.225V	60k to 80k
1.25V	60k to 80k

The default V_{OUT} needs to be set as 5V output, so that R2 value can be decided by the following equation :

$$R2 = \frac{R1}{\left(\frac{5V}{V_{REF}}\right) - 1}$$

The "Num" (register A6h, A7h) is a 10-bit number and each step is 25mV. The range of "Num" is 0 to 832 and the range of the output voltage (V_{OUT}) is 5V to 20V.

The output voltage (V_{OUT}) of the DC-DC converter can be programmed according to the following equation :

If the "Num" value is less than or equal to 200 :

$$V_{OUT} = 5V$$

If the "Num" value is greater than 200 :

$$V_{OUT} = 25mV \times \text{Num equal } 0 \text{ when the value is from } 0 \text{ to } 200.$$

For example :

Setting "Num" = 600 represents 15V output.

Setting "Num" = 0 to 200 represents 5V output.

I²C address Setting by the ADR Pin

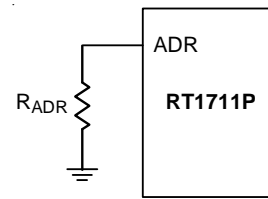

Figure 2

Figure 2 shows I²C address setting by R_{ADR} resistor

Where $R_{ADR} = 0\Omega$, the I²C address shows below :

1	0	0	1	1	0	0	R/W
MSB				LSB			

Where $R_{ADR} = 310k\Omega$, the I²C address shows below :

1	0	0	1	1	0	1	R/W
MSB				LSB			

Where $R_{ADR} = 670k\Omega$, the I²C address shows below :

1	0	0	1	1	1	0	R/W
MSB				LSB			

Where $R_{ADR} = \text{open}$, the I²C address shows below :

1	0	0	1	1	1	1	R/W
MSB				LSB			

Type-C Detection

The RT1711P implements multiple comparators that can be used by software to determine the state of the CC1, CC2 and VBUS pins. This status information provides the host processor with all of the information required to determine attach and detach status.

The RT1711P has three threshold comparators that match the USB Type-C specification for the three charge current levels that can be detected by a Type-C device. These comparators automatically cause interrupts to occur when there is a change of state.

The RT1711P also has a comparator that monitors if VBUS has reached a valid threshold or not. The DAC can be used to measure VBUS up to 20V which allows the software to confirm that changes to the VBUS line has occurred as expected based on Power Delivery (PD) to change the voltage level.

Detection through Autonomous DRP Toggles

The RT1711P has the capability to do autonomous DRP toggle. In DRP toggle the RT1711P implements DRP toggle between presenting as a SRC (source) and presenting as a SNK (sink). It can also present as a SRC or SNK only and monitor CC1, CC2 and VBUS status.

PD Protocol Communication

Type-C connector allows USB Power Delivery (PD) to be communicated over the connected CC pin between two ports. The communication method is the BMC Power Delivery protocol. Possible uses are outlined below.

- ▶ Negotiating and controlling power levels
- ▶ Alternative interfaces such as DisplayPort
- ▶ Role swap for dual-role ports that switch who is the source or sink
- ▶ Communication with USB Type-C full featured cables

The RT1711P integrates a BMC PD block which includes the BMC physical layer and packet buffer which allow packets to be sent and received by the host software through I2C accesses. The RT1711P allows host software to implement all features of USB BMC PD through writes and reads of the buffer and control of the RT1711P physical interface.

Abbreviations :

Term	Description
BMC	Biphase Mark Coding
TCPC	Type-C Port Controller
TCPCI	Type-C Port Controller Interface
TCPM	Type-C Port Manager

Type-C Port Controller (TCPC) Interface :

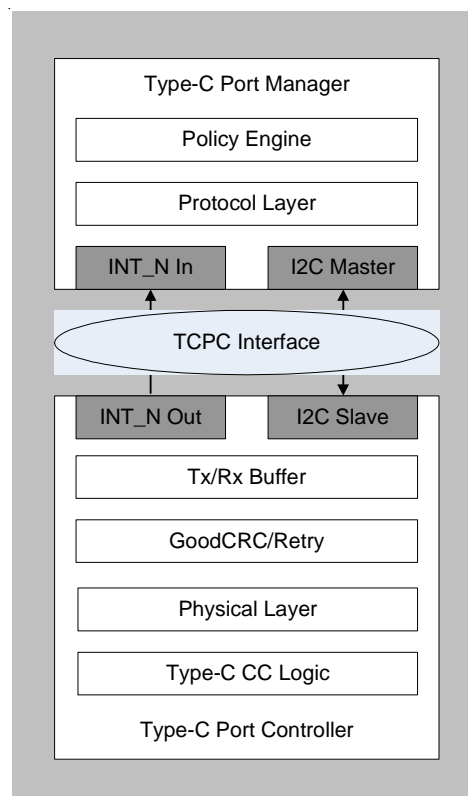

The Type-C Port Controller Interface, TCPCI, is the interface between a Type-C Port Manager and a Type-C Port Controller.

The Controller Interface uses the I²C Protocol :

- ▶ The TCPM is the only master on this I²C bus
- ▶ The TCPC is a slave device on this I²C bus
- ▶ Each Type-C port has its own unique I²C slave address
The TCPC shall have equal numbers of unique I²C slave addresses and supported Type-C ports
- ▶ The TCPC supports fast-mode bus speed

- ▶ The TCPC has an open drain output, active low INT_N Pin. This pin is used to indicate change of state, where INT_N pin is asserted when any Alert Bits are set
- ▶ The TCPCI supports an I/O nominal voltage range of 1.8V and 3.3V
- ▶ The TCPC can auto-increment the I²C internal register address of the last byte transferred during a read independent of an ACK/NACK from the master

Register Map :

Addr	Length	RegName	Bit	BitName	Default	Type	Description
0x00	1	VENDOR_ID	7:0	VID[7:0]	0	R	A unique 16-bit unsigned integer. Assigned by the USB-IF to the Vendor.
0x01	1		7:0	VID[15:8]	0	R	
0x02	1	PRODUCT_ID	7:0	PID[7:0]	0	R	A unique 16-bit unsigned integer. Assigned uniquely by the Vendor to identify the TCPC.
0x03	1		7:0	PID[15:8]	0	R	
0x04	1	DEVICE_ID	7:0	DID[7:0]	0	R	A unique 16-bit unsigned integer. Assigned by the Vendor to identify the version of the TCPC.
0x05	1		7:0	DID[15:8]	0	R	
0x06	1	USBTYPEC_REV	7:0	USBTYPEC_REV	0	R	Version number assigned by USB-IF (Currently at Revision 1.1 – 0001 0001)
0x07	1		7:0	Reserved	0	R	
0x08	1	USBPD_REV_VER	7:0	USBPD_VER	0	R	0001 0000 – Version 1.0 0001 0001 – Version 1.1 Etc.
0x09	1		7:0	USBPD_REV	0	R	0010 0000 – Revision 2.0
0x0A	1	PD_INTERFACE_REV	7:0	PDIF_VER	0	R	0001 0000 – Version 1.0 0001 0001 – Version 1.1 Etc.
0x0B	1		7:0	PDIF_REV	0	R	0010 0000 – Revision 2.0
0x10	1	ALERT	7	ALARM_VBUS_VOLTAGE_H	0	RW	0b : Cleared 1b : A high-voltage alarm has occurred
			6	TX_SUCCESS	0	RW	0b : Cleared, 1b : Reset or SOP* message transmission successful.
			5	TX_DISCARD	0	RW	0b: Cleared, 1b: Reset or SOP* message transmission not sent due to incoming receive message.
			4	TX_FAIL	0	RW	0b : Cleared, 1b : SOP* message transmission not successful, no GoodCRC response received on SOP* message transmission.
			3	RX_HARD_RESET	0	RW	0b : Cleared, 1b : Received Hard Reset message
			2	RX_SOP_MSG_STATUS	0	RW	0b : Cleared, 1b : Receive status register changed
			1	POWER_STATUS	0	RW	0b : Cleared, 1b : Port status changed
			0	CC_STATUS	0	RW	0b : Cleared, 1b : CC status changed

Addr	Length	RegName	Bit	BitName	Default	Type	Description
0x11	1	ALERT	7	Reserved	0	R	
			6	Reserved	0	R	
			5	Reserved	0	R	
			4	Reserved	0	R	
			3	VBUS_SINK_DISCNT	0	RW	0b : Cleared 1b : A VBUS Sink Disconnect Threshold crossing has been detected
			2	RXBUF_OVFLOW	0	RW	0b : TCPC Rx buffer is functioning properly. 1b : TCPC Rx buffer has overflowed.
			1	FAULT	0	RW	0b : No Fault. 1b : A Fault has occurred. Read the FAULT_STATUS register.
			0	ALARM_VBUS_VOLTAGE_L	0	RW	0b : Cleared 1b : A low-voltage alarm has occurred
0x12	1	ALERT_MASK	7	M_ALARM_VBUS_VOLTAGE_H	1	RW	0b : Interrupt masked, 1b : Interrupt unmasked
			6	M_TX_SUCCESS	1	RW	0b : Interrupt masked, 1b : Interrupt unmasked
			5	M_TX_DISCARD	1	RW	0b : Interrupt masked, 1b : Interrupt unmasked
			4	M_TX_FAIL	1	RW	0b : Interrupt masked, 1b : Interrupt unmasked
			3	M_RX_HARD_RESET	1	RW	0b : Interrupt masked, 1b : Interrupt unmasked
			2	M_RX_SOP_MSG_STATUS	1	RW	0b : Interrupt masked, 1b : Interrupt unmasked
			1	M_POWER_STATUS	1	RW	0b : Interrupt masked, 1b : Interrupt unmasked
			0	M_CC_STATUS	1	RW	0b : Interrupt masked, 1b : Interrupt unmasked
0x13	1	ALERT_MASK	7	Reserved	0	R	
			6	Reserved	0	R	
			5	Reserved	0	R	
			4	Reserved	0	R	
			3	M_VBUS_SINK_DISCNT	1	RW	0b : Interrupt masked, 1b : Interrupt unmasked
			2	M_RXBUF_OVFLOW	1	RW	0b : Interrupt masked, 1b : Interrupt unmasked
			1	M_FAULT	1	RW	0b : Interrupt masked, 1b : Interrupt unmasked
			0	M_ALARM_VBUS_VOLTAGE_L	1	RW	0b : Interrupt masked, 1b : Interrupt unmasked

Addr	Length	RegName	Bit	BitName	Default	Type	Description
0x14	1	POWER_STATUS_MASK	7	M_DBG_ACC_CONNECT	0	RW	0b : Interrupt masked, 1b : Interrupt unmasked
			6	M_TCPC_INITIAL	1	RW	0b : Interrupt masked, 1b : Interrupt unmasked
			5	M_SRC_HV	1	RW	0b : Interrupt masked, 1b : Interrupt unmasked
			4	M_SRC_VBUS	1	RW	0b: Interrupt masked, 1b: Interrupt unmasked
			3	M_VBUS_PRESENT_DETC	1	RW	0b : Interrupt masked, 1b : Interrupt unmasked
			2	M_VBUS_PRESENT	1	RW	0b : Interrupt masked, 1b : Interrupt unmasked
			1	M_VCONN_PRESENT	1	RW	0b : Interrupt masked, 1b : Interrupt unmasked
			0	M_SINK_VBUS	1	RW	0b : Interrupt masked, 1b : Interrupt unmasked
0x15	1	FAULT_STATUS_MASK	7	M_VCON_OV	0	RW	0b : Interrupt masked, 1b : Interrupt unmasked
			6	M_FORCE_OFF_VBUS	1	RW	0b : Interrupt masked, 1b : Interrupt unmasked
			5	M_AUTO_DISC_FAIL	1	RW	0b : Interrupt masked, 1b : Interrupt unmasked
			4	M_FORCE_DISC_FAIL	1	RW	0b : Interrupt masked, 1b : Interrupt unmasked
			3	M_VBUS_OC	1	RW	0b : Interrupt masked, 1b : Interrupt unmasked
			2	M_VBUS_OV	1	RW	0b : Interrupt masked, 1b : Interrupt unmasked
			1	M_VCON_OC	1	RW	0b : Interrupt masked, 1b : Interrupt unmasked
			0	M_I2C_ERROR	1	RW	0b : Interrupt masked, 1b : Interrupt unmasked
0x18	1	CONFIG_STANDARD_OUTPUT	7	H_IMPEDENCE	0	R	Not support.
			6	DBG_ACC_CONNECT_O	1	R	Not support.
			5	AUDIO_ACC_CONNECT	1	R	Not support.
			4	ACTIVE_CABLE_CONNECT	0	R	Not support.
			3:2	MUX_CTRL	0	R	Not support.
			1	CONNECT_PRESENT	0	R	Not support.
			0	CONNECT_ORIENT	0	R	Not support.

Addr	Length	RegName	Bit	BitName	Default	Type	Description
0x19	1	TCPC_CONTROL	7:5	Reserved	0	R	
			4	Reserved	0	R	
			3:2	I2C_CK_STRETCH	00	R	Not support.
			1	BIST_TEST_MODE	0	RW	0 : Normal Operation. Incoming messages enabled by RECEIVE_DETECT passed to TCPM via Alert. 1 : BIST Test Mode. Incoming messages enabled by RECEIVE_DETECT result in GoodCRC response but may not be passed to the TCPM via Alert. TCPC may temporarily store incoming messages in the Receive Message Buffer, but this may or may not result in a Receive SOP* Message Status or a Rx Buffer Overflow alert.
			0	PLUG_ORIENT	0	RW	0b : When Vconn is enabled, apply it to the CC2 pin. Monitor the CC1 pin for BMC communications if PD messaging is enabled. 1b : When Vconn is enabled, apply it to the CC1 pin. Monitor the CC2 pin for BMC communications if PD messaging is enabled. Required
0x1A	1	ROLE_CONTROL	7	Reserved	0	R	
			6	DRP	0	RW	0b : No DRP. Bits B3..0 determine Rp/Rd/Ra settings 1b: DRP
			5:4	RP_VALUE	0	RW	00b : Rp default 01b : Rp 1.5A 10b : Rp 3.0A 11b : Reserved
			3:2	CC2	10	RW	00b : Reserved 01b : Rp (Use Rp definition in B5..4) 10b : Rd 11b : Open (Disconnect or don't care) Set to 11b if enabling DRP in B7..6
			1:0	CC1	10	RW	00b : Reserved 01b : Rp (Use Rp definition in B5..4) 10b : Rd 11b : Open (Disconnect or don't care) Set to 11b if enabling DRP in B7..6

Addr	Length	RegName	Bit	BitName	Default	Type	Description
0x1B	1	FAULT_CONTROL	7	DIS_VCON_OV	0	RW	0b : Fault detection circuit enabled 1b : Fault detection circuit disabled
			6:5	Reserved	0	R	
			4	DIS_FORCE_OFF_VBUS	0	RW	0b : Allow STANDARD INPUT SIGNAL Force Off Vbus control (default) 1b : Block STANDARD INPUT SIGNAL Force Off Vbus control. VBUS gate control by setting register 0xBB[3:0]
			3	DIS_VBUS_DISC_FAULT_TIMER	0	RW	0b : VBUS Discharge Fault Detection Timer enabled 1b : VBUS Discharge Fault Detection Timer disabled
			2	DIS_VBUS_OC	0	RW	0b : Internal and External OCP circuit enabled 1b : Internal and External OCP circuit disabled
			1	DIS_VBUS_OV	0	RW	0b : Internal and External OVP circuit enabled 1b : Internal and External OVP circuit disabled
			0	DIS_VCON_OC	0	RW	0b : Fault detection circuit enabled 1b : Fault detection circuit disabled
0x1C	1	POWER_CONTROL	7	Reserved	0	R	
			6	VBUS_VOL_MONITOR	0	RW	0b : VBUS_VOLTAGE Monitoring is enabled (default) 1b : VBUS_VOLTAGE Monitoring is disabled
			5	DIS_VOL_ALARM	0	RW	0b: Voltage Alarms Power status reporting is enabled (default) 1b: Voltage Alarms Power status reporting is disabled
			4	AUTO_DISC_DISCNCT_EN	1	RW	0b : The TCPC shall not automatically discharge VBUS based on VBUS voltage. 1b : The TCPC shall automatically discharge during 50ms. (default)
			3	BLEED_DISC_EN	0	RW	0b : Disable bleed discharge (default) 1b : Enable bleed discharge of VBUS
			2	FORCE_DISC_EN	0	RW	0b : Disable forced discharge (default) 1b : Enable forced discharge of VBUS during 50ms.
			1	VCONN_POWER_SPT	0	RW	0b : TCPC delivers at least 1W on VCONN 1b : TCPC delivers at least the power indicated in DEVICE_CAPABILITIES. VCONNPowerSupported
			0	EN_VCONN	0	RW	0b : Disable VCONN Source (default) 1b : Enable VCONN Source to CC Required

Addr	Length	RegName	Bit	BitName	Default	Type	Description
0x1D	1	CC_STATUS	7:6	Reserved	0	R	
			5	DRP_STATUS	0	R	0b : the TCPC has stopped toggling or (ROLE_CONTROL.DRP = 00) 1b : the TCPC is toggling
			4	DRP_RESULT	0	R	0b : the TCPC is presenting Rp 1b : the TCPC is presenting Rd
			3:2	CC2_STATUS	0	R	If (ROLE_CONTROL.CC2 = Rp) or (DrpResult = 0) 00b : SRC.Open (Open, Rp) 01b : SRC.Ra (below maximum vRa) 10b : SRC.Rd (within the vRd range) 11b : reserved If (ROLE_CONTROL.CC2 = Rd) or (DrpResult = 1) 00b : SNK.Open (Below maximum vRa) 01b : SNK.Default (Above minimum vRd-Connect) 10b : SNK.Power1.5 (Above minimum vRd-Connect) Detects Rp 1.5A 11b : SNK.Power3.0 (Above minimum vRd-Connect) Detects Rp 3.0A If ROLE_CONTROL.CC2 = Ra, this field is set to 00b If ROLE_CONTROL.CC2 = Open, this field is set to 00b This field always returns 00b if (DrpStatus = 1) or (POWER_CONTROL.EnableVconn = 1 and POWER_CONTROL.PlugOrientation = 0). Otherwise, the returned value depends upon ROLE_CONTROL.CC2.
1:0	CC1_STATUS	0	R	If (ROLE_CONTROL.CC1 = Rp) or (DrpResult = 0) 00b : SRC.Open (Open, Rp) 01b : SRC.Ra (below maximum vRa) 10b : SRC.Rd (within the vRd range) 11b : reserved If (ROLE_CONTROL.CC1 = Rd) or DrpResult = 1) 00b : SNK.Open (Below maximum vRa) 01b : SNK.Default (Above minimum vRd-Connect) 10b : SNK.Power1.5 (Above minimum vRd-Connect) Detects Rp-1.5A 11b : SNK.Power3.0 (Above minimum vRd-Connect) Detects Rp-3.0A If ROLE_CONTROL.CC1 = Ra, this field is set to 00b If ROLE_CONTROL.CC1 = Open, this field is set to 00b This field always returns 00b if (DrpStatus = 1) or (POWER_CONTROL.EnableVconn = 1 and POWER_CONTROL.PlugOrientation = 0). Otherwise, the returned value depends upon ROLE_CONTROL.CC1.			

Addr	Length	RegName	Bit	BitName	Default	Type	Description
0x1E	1	POWER_STATUS	7	DBG_ACC_CONNECT	0	R	Not support.
			6	TCPC_INITIAL	0	R	0b : The TCPC has completed initialization and all registers are valid 1b : The TCPC is still performing internal initialization and the only registers that are guaranteed to return the correct values are 00h..0Fh
			5	SRC_HV	0	R	0b : vSafe5V 1b : High Voltage
			4	SRC_VBUS	0	R	0b : Sourcing Vbus is disabled 1b : Sourcing Vbus is enabled
			3	VBUS_PRESENT_DETC	0	R	0b : VBUS Present Detection Disabled 1b : VBUS Present Detection Enabled (default)
			2	VBUS_PRESENT	0	R	0b : VBUS Disconnected 1b : VBUS Connected
			1	VCONN_PRESENT	0	R	0b : VCONN is not present 1b : This bit is asserted when VCONN present CC1 or CC2. Threshold is fixed at 2.4V
			0	SINK_VBUS	0	R	0b : Sink is Disconnected (Default and if not supported) 1b : TCPC is sinking VBUS to the system load
0x1F	1	FAULT_STATUS	7	VCON_OV	0	RW	0b : Not in an over-voltage protection state 1b : Over-voltage fault latched.
			6	FORCE_OFF_VBUS	0	RW	0b : No Fault Detected, no action (default and not supported) 1b : VBUS Source/Sink has been forced off due to external fault
			5	AUTO_DISC_FAIL	0	RW	0b : No discharge failure 1b : Discharge commanded by the TCPM failed
			4	FORCE_DISC_FAIL	0	RW	0b : No discharge failure 1b : Discharge commanded by the TCPM failed.
			3	VBUS_OC	0	RW	0b : Not in an over-current protection state 1b : Over-current fault latched
			2	VBUS_OV	0	RW	0b : Not in an over-voltage protection state 1b : Over-voltage fault latched.
			1	VCON_OC	0	RW	0b : No Fault detected 1b : Over current VCONN fault latched
			0	I2C_ERROR	0	RW	

Addr	Length	RegName	Bit	BitName	Default	Type	Description
0x20	1		7:0	Reserved	0	R	
0x21	1		7:0	Reserved	0	R	
0x22	1		7:0	Reserved	0	R	
0x23	1	COMMAND	7:0	COMMAND	0	W	0010 0010b DisableVbusDetect. 0011 0011b EnableVbusDetect 0100 0100b DisableSinkVbus 0101 0101b Enable SinkVbus. 0110 0110b DisableSourceVbus. 0111 0111b SourceVbusDefaultVoltage. 1000 1000b SourceVbusHighVoltage.
0x24	1	DEVICE_CAPABILITIES_1L	7:5	ROLES_SUPPORT	110	R	000b : Type-C Port Manager can configure the Port as Source only or Sink only (not DRP) 001b : Source only 010b : Sink only 011b : Sink with accessory support (optional) 100b: DRP only 101b : Adapter or Cable (Ra) only 110b : Source, Sink, DRP, Adapter/Cable all supported 111b : Not valid
			4	ALL_SOP_SUPPORT	1	R	0b : All SOP* except SOP'_DBG/SOP''_DBG 1b : All SOP* messages are supported
			3	SOURCE_VCONN	1	R	0b : TCPC is not capable of switching VCONN 1b : TCPC is capable of switching VCONN
			2	CPB_SINK_VBUS	1	R	0b : TCPC is not capable controlling the sink path to the system load 1b : TCPC is capable of controlling the sink path to the system load
			1	SOURCE_HV_VBUS	1	R	0b : TCPC is not capable of controlling the source high voltage path to VBUS 1b : TCPC is capable of controlling the source high voltage path to VBUS
			0	SOURCE_VBUS	1	R	0b : TCPC is not capable of controlling the source path to VBUS 1b : TCPC is capable of controlling the source path to VBUS

Addr	Length	RegName	Bit	BitName	Default	Type	Description
0x25	1	DEVICE_CAPABILITIES_1H	7	Reserved	0	R	
			6	CPB_VBUS_OC	1	R	0b : VBUS OCP is not reported by the TCPC 1b : VBUS OCP is reported by the TCPC
			5	CPB_VBUS_OV	1	R	0b : VBUS OVP is not reported by the TCPC 1b : VBUS OVP is reported by the TCPC
			4	CPB_BLEED_DISC	1	R	0b : No Bleed Discharge implemented in TCPC 1b : Bleed Discharge is implemented in the TCPC
			3	CPB_FORCE_DISC	1	R	0b : No Force Discharge implemented in TCPC 1b : Force Discharge is implemented in the TCPC
			2	VBUS_MEASURE_ALARM	1	R	0b : No VBUS voltage measurement nor VBUS Alarms 1b : VBUS voltage measurement and VBUS Alarms
			1:0	SOURCE_RP_SUPPORT	10	R	00b : Rp default only 01b : Rp 1.5A and default 10b : Rp 3.0A, 1.5A, and default 11b : Reserved Rp values which may be configured by the TCPM via the ROLE_CONTROL register

Addr	Length	RegName	Bit	BitName	Default	Type	Description
0x26	1	DEVICE_CAPABILITIES_2L	7	SINK_DISCONNECT_DET	1	R	0b : VBUS_SINK_DISCONNECT_THRES HOLD not implemented (default : Use POWER_STATUS.VbusPresent = 0b to indicate a Sink disconnect) 1b : VBUS_SINK_DISCONNECT_THRES HOLD implemented
			6	STOP_DISC_THD	1	R	0b : VBUS_STOP_DISCHARGE_THRES HOLD not implemented (default) 1b : VBUS_STOP_DISCHARGE_THRES HOLD implemented
			5:4	VBUS_VOL_ALARM_LSB	00	R	00 : TCPC has 25mV LSB for its voltage alarm and uses all 10 bits in ... VBUS_VOLTAGE_ALARM_HI_CFG and ... VBUS_VOLTAGE_ALARM_LO_CFG. 01: TCPC has 50mV LSB for its voltage alarm and uses only 9 bits. ... VBUS_VOLTAGE_ALARM_HI_CFG[0] and ... VBUS_VOLTAGE_ALARM_LO_CFG[0] are ignored by TCPC. 10: TCPC has 100mV LSB for its voltage alarm and uses only 8 bits. ... VBUS_VOLTAGE_ALARM_HI_CFG[1 :0] and ... VBUS_VOLTAGE_ALARM_LO_CFG[1:0] are ignored by TCPC. 11 : reserved
			3:1	VCONN_POWER	010	R	000b : 1.0W 001b : 1.5W 010b : 2.0W 011b : 3W 100b : 4W 101b : 5W 110b : 6W 111b : External
			0	VCONN_OCF	1	R	0b : TCPC is not capable of detecting a Vconn fault 1b : TCPC is capable of detecting a Vconn fault

Addr	Length	RegName	Bit	BitName	Default	Type	Description
0x27	1	DEVICE_CAPABILITIES_2H	7:0	Reserved	0	R	
0x28	1	STANDARD_INPUT_CAPABILITIES	7:3	Reserved	0	R	
			2	VBUS_EXT_OVF	0	R	0b : Not present in TCPC 1b : Present in TCPC
			1	VBUS_EXT_OCF	0	R	0b : Not present in TCPC 1b : Present in TCPC
			0	FORCE_OFF_VBUS_IN	1	R	0b : Not present in TCPC 1b : Present in TCPC
0x29	1	STANDARD_OUTPUT_CAPABILITIES	7	Reserved	0	R	
			6	CPB_DBG_ACC_IND	0	R	0b : Not present in TCPC 1b : Present in TCPC
			5	CPB_VBUS_PRESENT_MNT	0	R	0b : Not present in TCPC 1b : Present in TCPC
			4	CPB_AUDIO_ADT_ACC_IND	0	R	0b : Not present in TCPC 1b : Present in TCPC
			3	CPB_ACTIVE_CABLE_IND	0	R	0b : Not present in TCPC 1b : Present in TCPC
			2	CPB_MUX_CFG_CTRL	0	R	0b : Not present in TCPC 1b : Present in TCPC
			1	CPB_CONNECT_PRESENT	0	R	0b : Not present in TCPC 1b : Present in TCPC
			0	CPB_CONNECT_ORIENT	0	R	0b : Not present in TCPC 1b : Present in TCPC
0x2E	1	MESSAGE_HEADER_INFO	7:5	Reserved	0	R	
			4	CABLE_PLUG	0	RW	0b : Message originated from Source, Sink, or DRP 1b : Message originated from a Cable Plug
			3	DATA_ROLE	0	RW	0b : Sink 1b : Source
			2:1	USBPD_SPECREV	01	RW	00b : Revision 1.0 01b : Revision 2.0 10b – 11b : Reserved
			0	POWER_ROLE	0	RW	0b : Sink 1b : Source

Addr	Length	RegName	Bit	BitName	Default	Type	Description
0x2F	1	RECEIVE_DETECT	7	Reserved	0	R	
			6	EN_CABLE_RST	0	RW	0b : TCPC does not detect Cable Reset signaling (default) 1b : TCPC detects Cable Reset signaling
			5	EN_HARD_RST	0	RW	0b: TCPC does not detect Hard Reset signaling (default) 1b: TCPC detects Hard Reset signaling
			4	EN_SOP2DB	0	RW	0b : TCPC does not detect SOP_DBG'' message (default) 1b : TCPC detects SOP_DBG'' message
			3	EN_SOP1DB	0	RW	0b : TCPC does not detect SOP_DBG' message (default) 1b: TCPC detects SOP_DBG' message
			2	EN_SOP2	0	RW	0b : TCPC does not detect SOP'' message (default) 1b : TCPC detects SOP'' message
			1	EN_SOP1	0	RW	0b : TCPC does not detect SOP' message (default) 1b : TCPC detects SOP' message
			0	EN_SOP	0	RW	0b : TCPC does not detect SOP message (default) 1b : TCPC detects SOP message
0x30	1	RX_BYTE_COUNT	7:0	RX_BYTE_COUNT	0	RW	Indicates number of bytes in this register that are not stale. The TCPC should read the first RECEIVE_BYTE_COUNT bytes in this register.
0x31	1	RX_BUF_FRAME_TYPE	7:3	Reserved	0	R	
			2:0	RX_FRAME_TYPE	0	R	Type of received frame 000b : Received SOP 001b : Received SOP' 010b : Received SOP'' 011b : Received SOP_DBG' 100b : Received SOP_DBG'' 110b : Received Cable Reset All others are reserved.
0x32	1	RX_BUF_HEADER_BYTE_0	7:0	RX_HEAD_0	0	R	Byte 0 (bits 7..0) of message header
0x33	1	RX_BUF_HEADER_BYTE_1	7:0	RX_HEAD_1	0	R	Byte 1 (bits 15..8) of message header
0x34	1	RX_BUF_OBJ1_BYTE_0	7:0	RX_OBJ1_0	0	R	Byte 0 (bits 7..0) of 1st data object
0x35	1	RX_BUF_OBJ1_BYTE_1	7:0	RX_OBJ1_1	0	R	Byte 1 (bits 15..8) of 1st data object
0x36	1	RX_BUF_OBJ1_BYTE_2	7:0	RX_OBJ1_2	0	R	Byte 2 (bits 23..16) of 1st data object
0x37	1	RX_BUF_OBJ1_BYTE_3	7:0	RX_OBJ1_3	0	R	Byte 3 (bits 31..24) of 1st data object
0x38	1	RX_BUF_OBJ2_BYTE_0	7:0	RX_OBJ2_0	0	R	Byte 0 (bits 7..0) of 2st data object

Addr	Length	RegName	Bit	BitName	Default	Type	Description
0x39	1	RX_BUF_OBJ2_BYTE_1	7:0	RX_OBJ2_1	0	R	Byte 1 (bits 15..8) of 2st data object
0x3A	1	RX_BUF_OBJ2_BYTE_2	7:0	RX_OBJ2_2	0	R	Byte 2 (bits 23..16) of 2st data object
0x3B	1	RX_BUF_OBJ2_BYTE_3	7:0	RX_OBJ2_3	0	R	Byte 3 (bits 31..24) of 2st data object
0x3C	1	RX_BUF_OBJ3_BYTE_0	7:0	RX_OBJ3_0	0	R	Byte 0 (bits 7..0) of 3st data object
0x3D	1	RX_BUF_OBJ3_BYTE_1	7:0	RX_OBJ3_1	0	R	Byte 1 (bits 15..8) of 3st data object
0x3E	1	RX_BUF_OBJ3_BYTE_2	7:0	RX_OBJ3_2	0	R	Byte 2 (bits 23..16) of 3st data object
0x3F	1	RX_BUF_OBJ3_BYTE_3	7:0	RX_OBJ3_3	0	R	Byte 3 (bits 31..24) of 3st data object
0x40	1	RX_BUF_OBJ4_BYTE_0	7:0	RX_OBJ4_0	0	R	Byte 0 (bits 7..0) of 4st data object
0x41	1	RX_BUF_OBJ4_BYTE_1	7:0	RX_OBJ4_1	0	R	Byte 1 (bits 15..8) of 4st data object
0x42	1	RX_BUF_OBJ4_BYTE_2	7:0	RX_OBJ4_2	0	R	Byte 2 (bits 23..16) of 4st data object
0x43	1	RX_BUF_OBJ4_BYTE_3	7:0	RX_OBJ4_3	0	R	Byte 3 (bits 31..24) of 4st data object
0x44	1	RX_BUF_OBJ5_BYTE_0	7:0	RX_OBJ5_0	0	R	Byte 0 (bits 7..0) of 5st data object
0x45	1	RX_BUF_OBJ5_BYTE_1	7:0	RX_OBJ5_1	0	R	Byte 1 (bits 15..8) of 5st data object
0x46	1	RX_BUF_OBJ5_BYTE_2	7:0	RX_OBJ5_2	0	R	Byte 2 (bits 23..16) of 5st data object
0x47	1	RX_BUF_OBJ5_BYTE_3	7:0	RX_OBJ5_3	0	R	Byte 3 (bits 31..24) of 5st data object
0x48	1	RX_BUF_OBJ6_BYTE_0	7:0	RX_OBJ6_0	0	R	Byte 0 (bits 7..0) of 6st data object
0x49	1	RX_BUF_OBJ6_BYTE_1	7:0	RX_OBJ6_1	0	R	Byte 1 (bits 15..8) of 6st data object
0x4A	1	RX_BUF_OBJ6_BYTE_2	7:0	RX_OBJ6_2	0	R	Byte 2 (bits 23..16) of 6st data object
0x4B	1	RX_BUF_OBJ6_BYTE_3	7:0	RX_OBJ6_3	0	R	Byte 3 (bits 31..24) of 6st data object
0x4C	1	RX_BUF_OBJ7_BYTE_0	7:0	RX_OBJ7_0	0	R	Byte 0 (bits 7..0) of 7st data object
0x4D	1	RX_BUF_OBJ7_BYTE_1	7:0	RX_OBJ7_1	0	R	Byte 1 (bits 15..8) of 7st data object
0x4E	1	RX_BUF_OBJ7_BYTE_2	7:0	RX_OBJ7_2	0	R	Byte 2 (bits 23..16) of 7st data object
0x4F	1	RX_BUF_OBJ7_BYTE_3	7:0	RX_OBJ7_3	0	R	Byte 3 (bits 31..24) of 7st data object
0x50	1	TX_BUF_FRAME_TYPE	7:6	Reserved	0	R	
			5:4	TX_RETRY_CNT	0	RW	00b : No message retry is required 01b : Automatically retry message transmission once 10b : Automatically retry message transmission twice 11b : Automatically retry message transmission three times
			3	Reserved	0	R	
			2:0	TX_FRAME_TYPE	0	RW	000b : Transmit SOP 001b : Transmit SOP' 010b : Transmit SOP'' 011b : Transmit SOP_DBG' 100b : Transmit SOP_DBG'' 101b : Transmit Hard Reset 110b : Transmit Cable Reset 111b : Transmit BIST Carrier Mode 2 (TCPC shall exit the BIST mode no later than tBISTContMode max)

Addr	Length	RegName	Bit	BitName	Default	Type	Description
0x51	1	TX_BYTE_COUNT	7:0	TX_BYTE_COUNT	0	RW	The number of bytes the TCPM will write
0x52	1	TX_BUF_HEADER_BYTE_0	7:0	TX_HEAD_0	0	RW	Byte 0 (bits 7..0) of message header
0x53	1	TX_BUF_HEADER_BYTE_1	7:0	TX_HEAD_1	0	RW	Byte 1 (bits 15..8) of message header
0x54	1	TX_BUF_OBJ1_BYTE_0	7:0	TX_OBJ1_0	0	RW	Byte 0 (bits 7..0) of 1st data object
0x55	1	TX_BUF_OBJ1_BYTE_1	7:0	TX_OBJ1_1	0	RW	Byte 1 (bits 15..8) of 1st data object
0x56	1	TX_BUF_OBJ1_BYTE_2	7:0	TX_OBJ1_2	0	RW	Byte 2 (bits 23..16) of 1st data object
0x57	1	TX_BUF_OBJ1_BYTE_3	7:0	TX_OBJ1_3	0	RW	Byte 3 (bits 31..24) of 1st data object
0x58	1	TX_BUF_OBJ2_BYTE_0	7:0	TX_OBJ2_0	0	RW	Byte 0 (bits 7..0) of 2st data object
0x59	1	TX_BUF_OBJ2_BYTE_1	7:0	TX_OBJ2_1	0	RW	Byte 1 (bits 15..8) of 2st data object
0x5A	1	TX_BUF_OBJ2_BYTE_2	7:0	TX_OBJ2_2	0	RW	Byte 2 (bits 23..16) of 2st data object
0x5B	1	TX_BUF_OBJ2_BYTE_3	7:0	TX_OBJ2_3	0	RW	Byte 3 (bits 31..24) of 2st data object
0x5C	1	TX_BUF_OBJ3_BYTE_0	7:0	TX_OBJ3_0	0	RW	Byte 0 (bits 7..0) of 3st data object
0x5D	1	TX_BUF_OBJ3_BYTE_1	7:0	TX_OBJ3_1	0	RW	Byte 1 (bits 15..8) of 3st data object
0x5E	1	TX_BUF_OBJ3_BYTE_2	7:0	TX_OBJ3_2	0	RW	Byte 2 (bits 23..16) of 3st data object
0x5F	1	TX_BUF_OBJ3_BYTE_3	7:0	TX_OBJ3_3	0	RW	Byte 3 (bits 31..24) of 3st data object
0x60	1	TX_BUF_OBJ4_BYTE_0	7:0	TX_OBJ4_0	0	RW	Byte 0 (bits 7..0) of 4st data object
0x61	1	TX_BUF_OBJ4_BYTE_1	7:0	TX_OBJ4_1	0	RW	Byte 1 (bits 15..8) of 4st data object
0x62	1	TX_BUF_OBJ4_BYTE_2	7:0	TX_OBJ4_2	0	RW	Byte 2 (bits 23..16) of 4st data object
0x63	1	TX_BUF_OBJ4_BYTE_3	7:0	TX_OBJ4_3	0	RW	Byte 3 (bits 31..24) of 4st data object
0x64	1	TX_BUF_OBJ5_BYTE_0	7:0	TX_OBJ5_0	0	RW	Byte 0 (bits 7..0) of 5st data object
0x65	1	TX_BUF_OBJ5_BYTE_1	7:0	TX_OBJ5_1	0	RW	Byte 1 (bits 15..8) of 5st data object
0x66	1	TX_BUF_OBJ5_BYTE_2	7:0	TX_OBJ5_2	0	RW	Byte 2 (bits 23..16) of 5st data object
0x67	1	TX_BUF_OBJ5_BYTE_3	7:0	TX_OBJ5_3	0	RW	Byte 3 (bits 31..24) of 5st data object
0x68	1	TX_BUF_OBJ6_BYTE_0	7:0	TX_OBJ6_0	0	RW	Byte 0 (bits 7..0) of 6st data object
0x69	1	TX_BUF_OBJ6_BYTE_1	7:0	TX_OBJ6_1	0	RW	Byte 1 (bits 15..8) of 6st data object
0x6A	1	TX_BUF_OBJ6_BYTE_2	7:0	TX_OBJ6_2	0	RW	Byte 2 (bits 23..16) of 6st data object
0x6B	1	TX_BUF_OBJ6_BYTE_3	7:0	TX_OBJ6_3	0	RW	Byte 3 (bits 31..24) of 6st data object
0x6C	1	TX_BUF_OBJ7_BYTE_0	7:0	TX_OBJ7_0	0	RW	Byte 0 (bits 7..0) of 7st data object
0x6D	1	TX_BUF_OBJ7_BYTE_1	7:0	TX_OBJ7_1	0	RW	Byte 1 (bits 15..8) of 7st data object
0x6E	1	TX_BUF_OBJ7_BYTE_2	7:0	TX_OBJ7_2	0	RW	Byte 2 (bits 23..16) of 7st data object
0x6F	1	TX_BUF_OBJ7_BYTE_3	7:0	TX_OBJ7_3	0	RW	Byte 3 (bits 31..24) of 7st data object
0x70	1	VBUS_VOLTAGE_L	7:0	VBUS_VOLTAGE[7:0]	0	R	Reading this register to determine the VBUS voltage

Addr	Length	RegName	Bit	BitName	Default	Type	Description
0x71	1	VBUS_VOLTAGE_H	7:4	Reserved	0	R	
			3:2	SCALE_FACTOR	0	RW	00 : VBUS measurement not scaled. 01 : VBUS measurement divided by 2 10 : VBUS measurement divided by 4 11 : reserved
			1:0	VBUS_VOLTAGE[9:8]	0	R	Reading this register to determine the VBUS voltage
0x72	1	VBUS_SINK_DISCONNECT_THRESHOLD_L	7:0	VBUS_SINK_DISCNT_THD[7:0]	C8	RW	VBUS_SINK_DISCONNECT_THRESHOLD
0x73	1	VBUS_SINK_DISCONNECT_THRESHOLD_H	7:2	Reserved	0	R	
			1:0	VBUS_SINK_DISCNT_THD[9:8]	0	RW	VBUS_SINK_DISCONNECT_THRESHOLD
0x74	1	VBUS_STOP_DISCHARGE_THRESHOLD_L	7:0	VBUS_STOP_DISCHG_THD[7:0]	0	RW	VBUS_STOP_DISCHARGE_THRESHOLD
0x75	1	VBUS_STOP_DISCHARGE_THRESHOLD_H	7:2	Reserved	0	R	
			1:0	VBUS_STOP_DISCHG_THD[9:8]	0	RW	VBUS_STOP_DISCHARGE_THRESHOLD
0x76	1	VBUS_VOLTAGE_ALARM_HI_L	7:0	VBUS_VOLTAGE_ALARM_HI[7:0]	0	RW	VBUS_VOLTAGE_ALARM_HI_CFG
0x77	1	VBUS_VOLTAGE_ALARM_HI_H	7:2	Reserved	0	R	
			1:0	VBUS_VOLTAGE_ALARM_HI[9:8]	0	RW	VBUS_VOLTAGE_ALARM_HI_CFG
0x78	1	VBUS_VOLTAGE_ALARM_LO_L	7:0	VBUS_VOLTAGE_ALARM_LO[7:0]	0	RW	VBUS_VOLTAGE_ALARM_LO_CFG
0x79	1	VBUS_VOLTAGE_ALARM_LO_H	7:2	Reserved	0	R	
			1:0	VBUS_VOLTAGE_ALARM_LO[9:8]	0	RW	VBUS_VOLTAGE_ALARM_LO_CFG
0xA5			7:5	VBUS_GP_FRMODE	0	RW	Power Path On when SINK receive Fast Role Swap 3'b001 : GP1B Path on (support fast role swap to use PMOS)
			4	Reserved	0	R	
			3	VBUS_GP1A_PN	0	RW	1'b0 : NMOS 1'b1 : PMOS
			2	VBUS_GP1B_PN	0	RW	1'b0 : NMOS 1'b1 : PMOS
			1	VBUS_GP2_PN	0	RW	1'b0 : NMOS 1'b1 : PMOS
			0	VBUS_GP3_PN	0	RW	1'b0 : NMOS 1'b1 : PMOS

Addr	Length	RegName	Bit	BitName	Default	Type	Description
0xA6	1	VBUS_VOL_L	7:0	VBUS_VOL_TARGET[7:0]	0	RW	Target VBUS voltage, LSB = 25mV Ex : VBUS = 20V, VBUS_VOL_TARGET[7:0] = 8'b00100000
0xA7	1	VBUS_VOL_H	7:2	Reserved	0	R	
			1:0	VBUS_VOL_TARGET[9:8]	0	RW	Target VBUS voltage, LSB = 25mV Ex : VBUS = 20V, VBUS_VOL_TARGET[9:8] = 2'b11
0xA8	1	VBUS_ADDA_CTRL	7	VBUS_DAC_EN	0	RW	1 : DAC enable
			0	VDC_EN	0	RW	0b: VDC detector circuit enabled 1b: VDC detector circuit disabled
0xA9	1	VBUS_GP_CTRL	7:6	VBUS_GP1A_EN	0	RW	VBUS CP GP1A path enable 2'b00 -> open 2'b01 -> pull Lo 2'b10 -> pull Lo 2'b11 -> pull Hi
			5:4	VBUS_GP1B_EN	0	RW	VBUS CP GP1B path enable 2'b00 -> open 2'b01 -> pull Lo 2'b10 -> pull Lo 2'b11 -> pull Hi
			3:2	VBUS_GP2_EN	0	RW	VBUS CP GP2 path enable 2'b00 -> open 2'b01 -> pull Lo 2'b10 -> pull Lo 2'b11 -> pull Hi
			1:0	VBUS_GP3_EN	0	RW	VBUS CP GP3 path enable 2'b00 -> open 2'b01 -> pull Lo 2'b10 -> pull Lo 2'b11 -> pull Hi
0xAA	1	FAST_ROLE_SWAP	7	VBUS_CPEN	0	RW	VBUS related CP enable 1'b0 : disable 1'b1 : enable
			6	VDC_CPEN	0	RW	VDC related CP enable 1'b0 : disable 1'b1 : enable
			5	Reserved	0	R	
			4:3	Reserved	0	R	
			1	Reserved	0	R	
			0	FR_RXDET_EN	0	RW	Fast-role swap rx detection enable 1'b0 -> off 1'b1 -> fast role swap detection

Addr	Length	RegName	Bit	BitName	Default	Type	Description
0xAB	1	VBUS_DISCHG	7:4	Reserved	0	RW	
			3:0	VBUS_VALUE	0	RW	VBUS steady-state voltage by PD contrast 4'b0000->5V 4'b0001->6V 4'b0010->7V 4'b0011->8V 4'b0100->9V 4'b0101->10V 4'b0110->11V 4'b0111->12V 4'b1000->13V 4'b1001->14V 4'b1010->15V 4'b1011->16V 4'b1100->17V 4'b1101->18V 4'b1110->19V 4'b1111->20V
0xAC	1	VBUS_OCPR	5:4	VBUS_OVPRATIO	10	RW	VBUS OVP ration based on VBUS_VALUE * (1 + 5 ~ 20%) 2'b00 : 5% 2'b01 : 10% 2'b10 : 15% 2'b11 : 20%
			3:0	VBUS_OCP	0001	RW	VBUS Over current control selection 4'b0000 : 0.5A * 120% 4'b0001 : 1A * 120% 4'b0010 : 1.5A * 120% 4'b0011 : 2A * 120% 4'b0100 : 2.5A * 120% 4'b0101 : 3A * 120% 4'b0110 : 3.5A * 120% 4'b0111 : 4A * 120% 4'b1000 : 4.5A * 120% 4'b1001 : 5A * 120%
0xAD	1	VBUS_SOFT	7:6	Reserved	0	R	
			5:3	VBUS_SOFT1_VBUS	100	RW	VBUS Soft-start control (path1) 3'b111 -> 3'b001 (fast to slow), 3'b000 -> closed
			2:0	VBUS_SOFT2_VBUS	100	RW	VBUS Soft-start control (path2) 3'b111 -> 3'b001 (fast to slow), 3'b000 -> closed
0xAF	1		7:6	Reserved	0	R	
			5	ENPD3	0	RW	Enable PD 3.0 function.
			4	TRANSMIT_FRSWAP	0	TRG_1	Write 1 to output 1 for 1T PCLK
			3:0	TFRSWAPRX	1100	RW	Debounce FR_RXDET signal by 300K clock

Addr	Length	RegName	Bit	BitName	Default	Type	Description
0xB0	1	GPIO1	7	Reserved	0	R	
			6	Reserved	0	R	
			5	GPIO1_PU_EN	0	RW	1 : pull-up enable
			4	GPIO1_DS	0	RW	0 : Low-drive, 1 : High-drive
			3	GPIO1_OD_N	0	RW	0 : open-drain, 1 : push-pull
			2	GPIO1_OE	0	RW	GPIO1 output enable
			1	GPIO1_O	0	RW	GPIO1 output
			0	GPIO1_I	0	R	GPIO1 input
0xB1	1	GPIO2	7	Reserved	0	R	
			6	Reserved	0	R	
			5	GPIO2_PU_EN	0	RW	1: pull-up enable
			4	GPIO2_DS	0	RW	0 : Low-drive, 1 : High-drive
			3	GPIO2_OD_N	0	RW	0 : open-drain, 1 : push-pull
			2	GPIO2_OE	0	RW	GPIO2 output enable
			1	GPIO2_O	0	RW	GPIO2 output
			0	GPIO2_I	0	R	GPIO2 input
0xB2	1	GPIO3	7	Reserved	0	R	
			6	Reserved	0	R	
			5	GPIO3_PU_EN	0	RW	1 : pull-up enable
			4	GPIO3_DS	0	RW	0 : Low-drive, 1 : High-drive
			3	GPIO3_OD_N	0	RW	0 : open-drain, 1 : push-pull
			2	GPIO3_OE	0	RW	GPIO3 output enable
			1	GPIO3_O	0	RW	GPIO3 output
			0	GPIO3_I	0	R	GPIO3 input
0xB3	1	GPIO4	7	Reserved	0	R	
			6	Reserved	0	R	
			5	GPIO4_PU_EN	0	RW	1 : pull-up enable
			4	GPIO4_DS	0	RW	0 : Low-drive, 1 : High-drive
			3	GPIO4_OD_N	0	RW	0 : open-drain, 1 : push-pull
			2	GPIO4_OE	0	RW	GPIO4 output enable
			1	GPIO4_O	0	RW	GPIO4 output
			0	GPIO4_I	0	R	GPIO4 input

Addr	Length	RegName	Bit	BitName	Default	Type	Description
0xB4	1	GPIO5	7	Reserved	0	R	
			6	Reserved	0	R	
			5	GPIO5_PU_EN	0	RW	1 : pull-up enable
			4	GPIO5_DS	0	RW	0 : Low-drive, 1 : High-drive
			3	GPIO5_OD_N	0	RW	0 : open-drain, 1 : push-pull
			2	GPIO5_OE	0	RW	GPIO5 output enable
			1	GPIO5_O	0	RW	GPIO5 output
			0	GPIO5_I	0	R	GPIO5 input
0xB5	1		7	Reserved	0	R	
			6:4	VBUS_DISCHARGE_TIME	111	RW	TIME = (VBUS_DISCHARGE_TIME + 0.5) * 6.4ms
0xB6	1	DIS_SNK_VBUS_GP_EN	7:6	DIS_SNK_VBUS_GP1A_EN	0	RW	Sink VBUS setting in disable, over-voltage, over-current status 2'b00 -> open 2'b01 -> pull Lo 2'b10 -> pull Lo 2'b11 -> pull Hi
			5:4	DIS_SNK_VBUS_GP1B_EN	0	RW	
			3:2	DIS_SNK_VBUS_GP2_EN	0	RW	
			1:0	DIS_SNK_VBUS_GP3_EN	0	RW	
0xB7	1	ENA_SNK_VBUS_GP_EN	7:6	ENA_SNK_VBUS_GP1A_EN	0	RW	Sink VBUS setting in enable 2'b00 -> open 2'b01 -> pull Lo 2'b10 -> pull Lo 2'b11 -> pull Hi
			5:4	ENA_SNK_VBUS_GP1B_EN	0	RW	
			3:2	ENA_SNK_VBUS_GP2_EN	0	RW	
			1:0	ENA_SNK_VBUS_GP3_EN	0	RW	
0xB8	1	DIS_SRC_VBUS_GP_EN	7:6	DIS_SRC_VBUS_GP1A_EN	0	RW	Source VBUS setting in disable, over-voltage, over-current status 2'b00 -> open 2'b01 -> pull Lo 2'b10 -> pull Lo 2'b11 -> pull Hi
			5:4	DIS_SRC_VBUS_GP1B_EN	0	RW	
			3:2	DIS_SRC_VBUS_GP2_EN	0	RW	
			1:0	DIS_SRC_VBUS_GP3_EN	0	RW	
0xB9	1	ENA_SRC_VBUS_GP_EN	7:6	ENA_SRC_VBUS_GP1A_EN	0	RW	Source VBUS setting in enable 2'b00 -> open 2'b01 -> pull Lo 2'b10 -> pull Lo 2'b11 -> pull Hi
			5:4	ENA_SRC_VBUS_GP1B_EN	0	RW	
			3:2	ENA_SRC_VBUS_GP2_EN	0	RW	
			1:0	ENA_SRC_VBUS_GP3_EN	0	RW	
0xBA	1	ENA_SRC_HV_VBUS_US_GP_EN	7:6	ENA_SRC_HV_VBUS_GP1A_EN	0	RW	Source HV_VBUS setting in enable 2'b00 -> open 2'b01 -> pull Lo 2'b10 -> pull Lo 2'b11 -> pull Hi
			5:4	ENA_SRC_HV_VBUS_GP1B_EN	0	RW	
			3:2	ENA_SRC_HV_VBUS_GP2_EN	0	RW	
			1:0	ENA_SRC_HV_VBUS_GP3_EN	0	RW	

Addr	Length	RegName	Bit	BitName	Default	Type	Description
0xBB	1		7:5	Reserved	0	R	
			4	ADR_EN	0	R	0 : ADDRESS value is not valid 1 : ADDRESS value is valid
			3:2	EN_PIN_SEL2	0	RW	2'b00 -> open 2'b01 -> pull Lo 2'b10 -> pull Lo 2'b11 -> pull Hi
			1:0	EN_PIN_SEL1	0	RW	2'b00 -> open 2'b01 -> pull Lo 2'b10 -> pull Lo 2'b11 -> pull Hi
0xBC	1		7	Reserved	0	R	
			6:0	TVBUSOCPEN	0101000	RW	VBUS_OCP = 2A period after VBUS_OCP_EN is 1 range from 0 to 3200μs (by CK_40K)
0xBF	1		7:3	Reserved	11000	RW	
			2:0	VDCLEVEL	000	RW	VDC decision threshold selection (MSB inversion) 3'b000 -> 4V (VDC_valid <0X97> flag rising to high when VDC > 4V) 3'b001 -> 6V 3'b010 -> 8V 3'b011 -> 11V 3'b100 -> 13V 3'b101-> 15V 3'b110 -> 18V 3'b111 -> 21V

Thermal Considerations

The junction temperature should never exceed the absolute maximum junction temperature $T_{J(MAX)}$, listed under Absolute Maximum Ratings, to avoid permanent damage to the device. The maximum allowable power dissipation depends on the thermal resistance of the IC package, the PCB layout, the rate of surrounding airflow, and the difference between the junction and ambient temperatures. The maximum power dissipation can be calculated using the following formula :

$$P_{D(MAX)} = (T_{J(MAX)} - T_A) / \theta_{JA}$$

where $T_{J(MAX)}$ is the maximum junction temperature, T_A is the ambient temperature, and θ_{JA} is the junction-to-ambient thermal resistance.

For continuous operation, the maximum operating junction temperature indicated under Recommended Operating Conditions is 125°C. The junction-to-ambient thermal resistance, θ_{JA} , is highly package dependent. For a WQFN-24L 3.5x3.5 package, the thermal resistance, θ_{JA} , is 28.5°C/W on a standard JEDEC 51-7 high effective-thermal-conductivity four-layer test board. The maximum power dissipation at $T_A = 25^\circ\text{C}$ can be calculated as below:

$$P_{D(MAX)} = (125^\circ\text{C} - 25^\circ\text{C}) / (28.5^\circ\text{C/W}) = 3.5\text{W for a WQFN-24L 3.5x3.5 package.}$$

The maximum power dissipation depends on the operating ambient temperature for the fixed $T_{J(MAX)}$ and the thermal resistance, θ_{JA} . The derating curves in Figure 3 allows the designer to see the effect of rising ambient temperature on the maximum power dissipation.

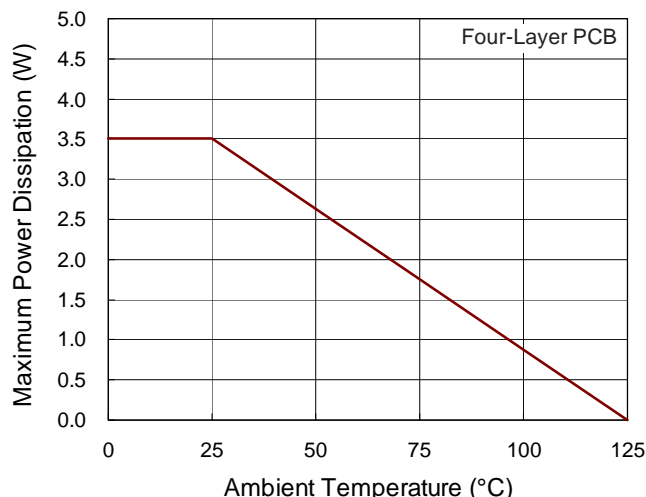
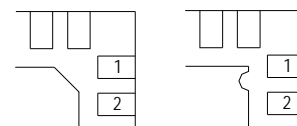
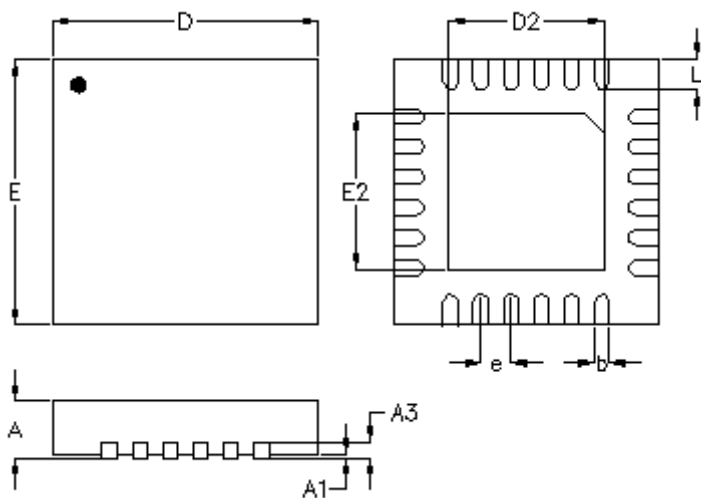

Figure 3. Derating Curve of Maximum Power Dissipation

Outline Dimension



DETAIL A

Pin #1 ID and Tie Bar Mark Options

Note : The configuration of the Pin #1 identifier is optional, but must be located within the zone indicated.

Symbol	Dimensions In Millimeters		Dimensions In Inches	
	Min	Max	Min	Max
A	0.700	0.800	0.028	0.031
A1	0.000	0.050	0.000	0.002
A3	0.175	0.250	0.007	0.010
b	0.150	0.250	0.006	0.010
D	3.400	3.600	0.134	0.142
D2	2.000	2.100	0.079	0.083
E	3.400	3.600	0.134	0.142
E2	2.000	2.100	0.079	0.083
e	0.400		0.016	
L	0.350	0.450	0.014	0.018

W-Type 24L QFN 3.5x3.5 Package

Footprint Information

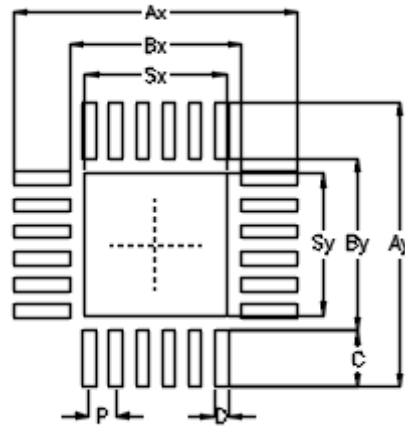

Package	Number of Pin	Footprint Dimension (mm)									Tolerance
		P	Ax	Ay	Bx	By	C	D	Sx	Sy	
V/W/U/XQFN3.5*3.5-24	24	0.40	4.30	4.30	2.60	2.60	0.85	0.20	2.15	2.15	±0.05

Richtek Technology Corporation

14F, No. 8, Tai Yuen 1st Street, Chupei City
 Hsinchu, Taiwan, R.O.C.
 Tel: (8863)5526789

Richtek products are sold by description only. Richtek reserves the right to change the circuitry and/or specifications without notice at any time. Customers should obtain the latest relevant information and data sheets before placing orders and should verify that such information is current and complete. Richtek cannot assume responsibility for use of any circuitry other than circuitry entirely embodied in a Richtek product. Information furnished by Richtek is believed to be accurate and reliable. However, no responsibility is assumed by Richtek or its subsidiaries for its use; nor for any infringements of patents or other rights of third parties which may result from its use. No license is granted by implication or otherwise under any patent or patent rights of Richtek or its subsidiaries.

X-ON Electronics

Largest Supplier of Electrical and Electronic Components

Click to view similar products for [USB Interface IC](#) category:

Click to view products by [Richtek](#) manufacturer:

Other Similar products are found below :

[CY7C65210-24LTXI](#) [CY7C69356-48LTXC](#) [CYUSB2304-68LTXI](#) [CYPD2119-24LQXI](#) [USB2227-NU-11](#) [USB3319C-GJ-TR](#) [USB3370B-EZK-TR](#) [PTN5150AHXMP](#) [CY7C65215A-32LTXI](#) [CYPD2120-24LQXI](#) [CYWB0164BB-BZXI](#) [CYWB0224ABS-BZXI](#) [CY7C65211A-24LTXI](#) [USB3803CI-1-GL-TR](#) [USB2422T-I/MJ](#) [UPD720114GA-YEU-AT](#) [CYPD2122-20FNXIT](#) [CYPD2122-24LQXIT](#) [LIF-UC120-SWG36ITR50](#) [UPD360-B/6HX](#) [UPD360-A/6HX](#) [CP2102NP1174GM](#) [CY7C65642-28LTXCT](#) [CG8454AM](#) [CYUSB2025-BZXI](#) [DPO2039DABQ-13](#) [FUSB303BTMX](#) [PTN3816EWY](#) [UPD720211K8-711-BAL-A](#) [PTN38007EWY](#) [CYPM1111-40LQXI](#) [CY7C65216D-32LTXI](#) [USB3317C-GJ-TR](#) [iW657P-65-56BB](#) [CY7C68034-56LTXC](#) [TUSB213IRGYT](#) [TUSB213RGYT](#) [TUSB214RWBT](#) [USB2517I-JZX-TR](#) [USB3318-CP](#) [USB3343-CP](#) [USB3503T-I/ML](#) [CHY100D-TL](#) [STUSB1602AQTR](#) [TUSB214IRWBT](#) [TUSB8043RGCT](#) [USB3319C-CP-TR](#) [USB2532I-1080AEN](#) [CY7C63310-SXC](#) [CY7C64215-28PVXI](#)