

## Dual Output AMOLED Bias

### General Description

The RT4723 is a highly integrated Boost, LDO and inverting charge pump to generate positive and negative output voltage. The negative output voltages can be adjusted from  $-0.6V$  to  $-2.4V$  with  $100mV$  steps by SWIRE interface protocol. The part maintains the highest efficiency by utilizing a  $-0.33x/-0.5x$  mode fractional charge pump with automatic mode transition. With its input voltage range of  $2.5V$  to  $4.6V$ , the RT4723 is optimized for products powered by single-cell battery and the output current up to  $55mA$ . The RT4723 is available in WL-CSP-15B  $1.39 \times 2.07$  (BSC) package to achieve optimized solution for PCB space.

### Ordering Information

RT4723 □

Package Type  
WSC : WL-CSP-15B  $1.39 \times 2.07$  (BSC)

Note :

Richtek products are :

- ▶ RoHS compliant and compatible with the current requirements of IPC/JEDEC J-STD-020.
- ▶ Suitable for use in SnPb or Pb-free soldering processes.

### Features

- 2.5V to 4.6V Supply Voltage Range
- Single Wire Protocol
- Fixed 4.6V Positive Voltage Output
- Negative Voltage Output from  $-0.6V$  to  $-2.4V$  per  $0.1V$  by SWIRE Pin
- Auto-Mode Transition of  $-0.33x/-0.5x$  Charge Pump
- Built-in Soft-Start
- 55mA Maximum Output Current
- Programmable Output Fast Discharge Function
- High Impedance Output when IC Shutdown
- UVLO, OCP, SCP, OTP Protection
- Shutdown Current  $< 1\mu A$
- Available in 15-Ball WL-CSP Package

### Applications

- AMOLED Bias in Portable Device

### Marking Information

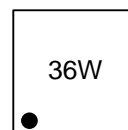

36 : Product Code  
W : Date Code

### Simplified Application Circuit

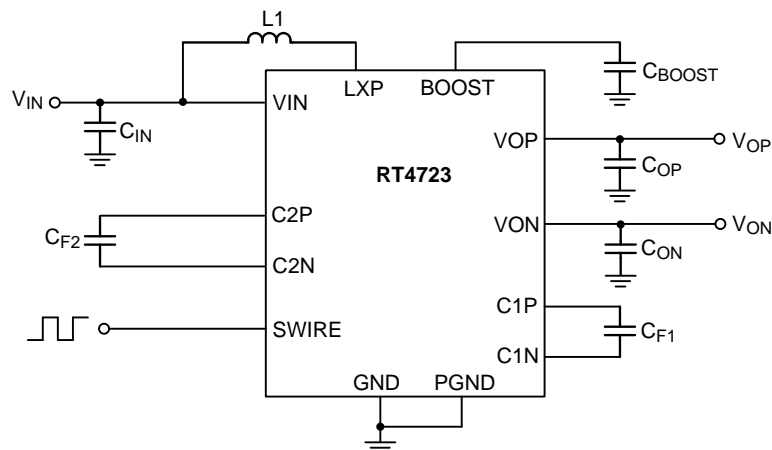

Pin Configuration

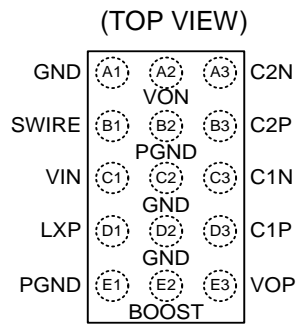

WL-CSP-15B 1.39x2.07 (BSC)

Functional Pin Description

Pin No.	Pin Name	Pin Function
A1, C2, D2	GND	Ground.
A2	VON	Negative terminal output.
A3	C2N	Flying capacitor 2 negative connection.
B1	SWIRE	Enable and VON voltage setting.
B2, E1	PGND	Power ground.
B3	C2P	Flying capacitor 2 positive connection.
C1	VIN	Power input.
C3	C1N	Flying capacitor 1 negative connection.
D1	LXP	Switching node of boost converter.
D3	C1P	Flying capacitor 1 positive connection.
E2	BOOST	Output voltage of boost converter.
E3	VOP	Positive terminal output.

**Functional Block Diagram**

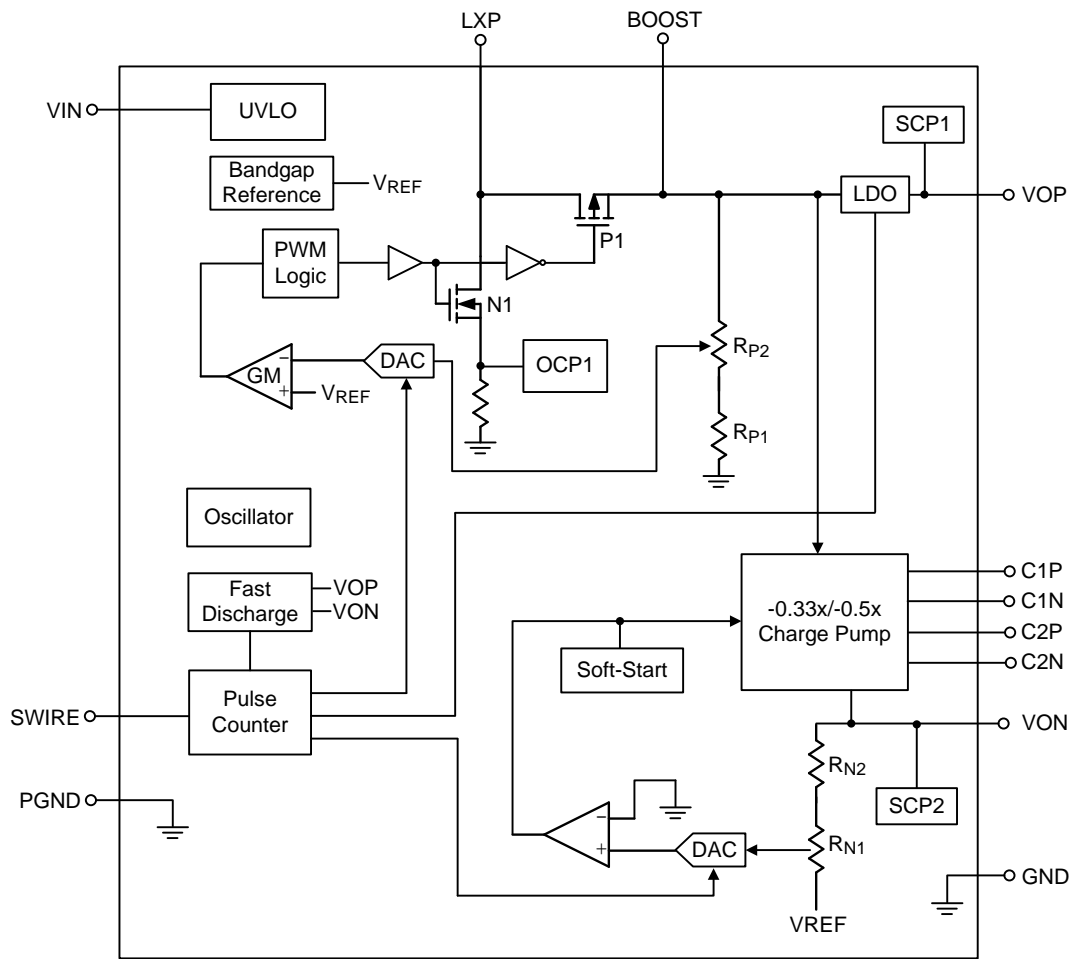

**Operation**

The RT4723 is a highly integrated Boost, LDO and inverting charge pump to generate positive and negative output voltage. It can support input voltage range from 2.5V to 4.6V and the output current up to 55mA. The VOP positive output voltage is set at a typical value of 4.6V. The VON negative output voltage is set at a typical value of -2.4V and can be programmed through single wire protocol (SWIRE pin).

The available voltage range is from -0.6V to -2.4V with 100mV per step. The RT4723 provides Over-Temperature Protection (OTP) and Short Circuit Protection (SCP) mechanisms to prevent the device from damage with abnormal operations. When the SWIRE voltage is logic low for more than 350µs, the IC will be shut down with low input supply current less than 1µA.

## Absolute Maximum Ratings (Note 1)

- Supply Input Voltage VIN Pin-----0.3V to 6V
- Output voltage VOP Pin -----0.3V to 6V
- Output voltage VON Pin -----6V to 0.3V
- Others pin to GND -----0.3V to 6V
- Power Dissipation, PD @ TA = 25°C  
 WL-CSP-15B 1.39x2.07 (BSC) ----- 2W
- Package Thermal Resistance (Note 2)  
 WL-CSP-15B 1.39x2.07 (BSC),  $\theta_{JA}$  -----49.8°C/W
- Lead Temperature (Soldering, 10 sec.) -----260°C
- Junction Temperature -----150°C
- Storage Temperature Range -----65°C to 150°C
- ESD Susceptibility (Note 3)  
 HBM (Human Body Model) -----2kV  
 MM (Machine Model) -----200V

## Recommended Operating Conditions (Note 4)

- Supply Input Voltage Range----- 2.5V to 4.6V
- Positive Output Voltage----- 4.6V
- Negative Output Voltage Range----- -2.4V to -0.6V
- Ambient Temperature Range ----- -40°C to 85°C
- Junction Temperature Range ----- -40°C to 125°C

## Electrical Characteristics

(VIN = 3.7V, VOP = 4.6V, VON = -2.4V, CIN = 4.7μF, CBOOST = 20μF, COP = 10μF, CON = 30μF, CF1 = 1μF, L1 = 2.2μH, TA = 25°C, unless otherwise specified.)

Parameter	Symbol	Test Conditions	Min	Typ	Max	Unit
<b>Power Supply</b>						
Input Voltage Range	VIN		2.5	--	4.6	V
Under Voltage Lockout Threshold Voltage	VUVLO_H	VIN rising	--	2.2	2.5	V
	VUVLO_L	VIN falling	--	2.1	2.3	V
Over-temperature Protection	TOTP	(Note 5)	--	140	--	°C
Over-temperature Protection Hysteresis	TOTP_HYST	(Note 5)	--	15	--	°C
Shutdown Current	ISHDN	SWIRE = 0V	--	--	1	μA
Efficiency Peak 1	Eff_1	IOP = ION = 1mA (Note 5)	--	58	--	%
Efficiency Peak 2	Eff_2	IOP = ION = 5mA (Note 5)	--	75	--	%
Efficiency Peak 3	Eff_3	IOP = ION = 15mA (Note 5)	--	83	--	%
<b>LDO Output</b>						
Positive Output Voltage Range	VOP		--	4.6	--	V

Parameter	Symbol	Test Conditions	Min	Typ	Max	Unit
Positive Output Voltage Accuracy	VOP_ACC		-1	--	1	%
Positive Output Current Capability	IOP_MAX		--	--	55	mA
Positive Output Voltage Ripple	VOP_RIPPLE	IOP = 20mA (Note 5)	--	10	--	mV
Line Regulation	VOP_LINE	VIN = 2.9 to 4.5V, IOP = 20mA (Note 5)	--	5	--	mV
Load Regulation	VOP_LOAD	IOP = 0mA to 30mA (Note 5)	--	5	--	mV
Fast Discharge Resistance	RDISP		--	105	--	Ω
Short Circuit Protection	VSCP1		--	< 80% VOP	--	V
<b>Charge Pump Output</b>						
Negative Output Voltage Range	VON		-2.4	--	-0.6	V
Negative Output Voltage Setting Range	VON_SET	Per step	--	100	--	mV
Negative Output Voltage Accuracy	VON_ACC		-1	--	1	%
Negative Output Current Capability	ION_MAX	(Note 5)	--	--	30	mA
	ION_HBM	VON = -2.2V (Note 5)	--	--	55	
Negative Charge Pump Switching Frequency	fOSC_N		0.8	1	1.2	MHz
Negative Output Voltage Ripple	VON_RIPPLE	ION = 20mA (Note 5)	--	20	--	mV
Line Regulation	VON_LINE	VIN = 2.9 to 4.5V, ION = 20mA (Note 5)	--	10	--	mV
Load Regulation	VON_LOAD	ION = 0mA to 30mA (Note 5)	--	30	--	mV
Fast Discharge Resistance	RDISN		--	60	--	Ω
Short Circuit Protection	VSCP2		--	> 80% VON	--	V
<b>Logic Input (SWIRE)</b>						
SWIRE Turn-off Detection Time	toff_dly		350	--	--	μs
SWIRE Signal Stop Indicate Time	tstop		350	--	--	μs
Twait after Data	twait_int		10	--	--	ms
Rising Input High Threshold Voltage Level	VIH		1.2	--	VIN	V
Falling Input Low Threshold Voltage Level	VIL		0	--	0.4	V
SWIRE Pull Low Resistor	RSWIRE		--	300	--	kΩ
Wake up Delay	twkp		--	--	1	μs

Parameter	Symbol	Test Conditions	Min	Typ	Max	Unit
SWIRE Rising Time	t <sub>R</sub>		--	--	200	ns
SWIRE Falling Time	t <sub>F</sub>		--	--	200	ns
Clocked SWIRE High	t <sub>ON</sub>		2	10	40	μs
Clocked SWIRE Low	t <sub>OFF</sub>		2	10	40	μs
SWIRE to VOP On Time	t <sub>VOP_ON</sub>		--	1.6	--	ms
Input Clocked SWIRE Frequency	f <sub>SWIRE</sub>		25	--	250	kHz

**Note 1.** Stresses beyond those listed under “Absolute Maximum Ratings” may cause permanent damage to the device. These are stress ratings only, and functional operation of the device at these or any other conditions beyond those indicated in the operational sections of the specifications is not implied. Exposure to absolute maximum rating conditions may affect device reliability.

**Note 2.**  $\theta_{JA}$  is measured under natural convection (still air) at  $T_A = 25^\circ\text{C}$  with the component mounted on a high effective-thermal-conductivity four-layer test board on a JEDEC 51-7 thermal measurement standard.

**Note 3.** Devices are ESD sensitive. Handling precaution recommended.

**Note 4.** The device is not guaranteed to function outside its operating conditions.

**Note 5.** Spec. is guaranteed by design.

Typical Application Circuit

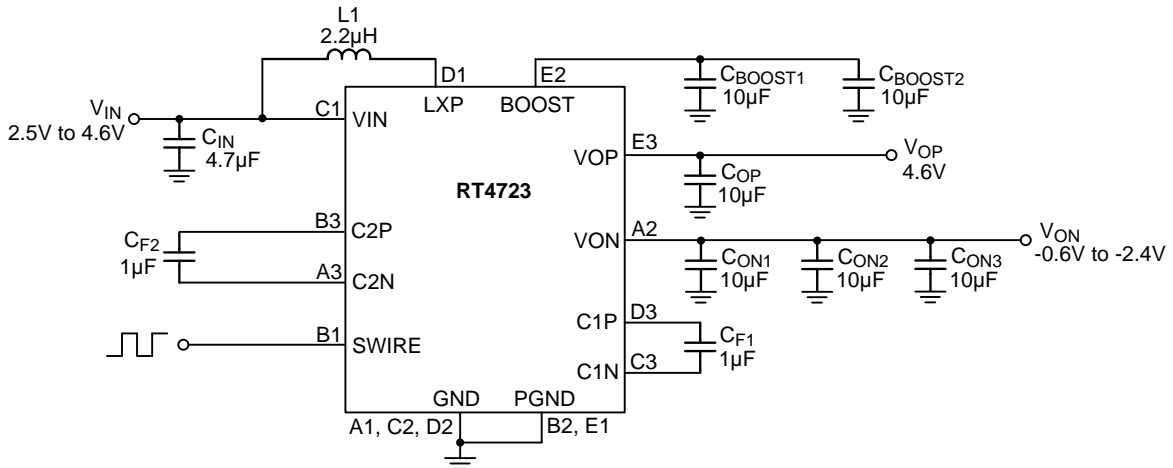
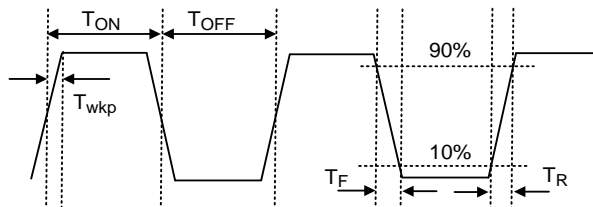

Table 1. Component List of Evaluation Board

Reference	Qty.	Part Number	Description	Package	Supplier
CIN	1	GRM188R61C475KAAJ	4.7µF/16V/X5R	0603	Murata
CBOOST1, CBOOST2, COP, CON1, CON2, CON3	6	GRM188R61A106KE69	10µF/10V/X5R	0603	Murata
CF1, CF2	2	GRM155R61C105KE01	1µF/16V/X5R	0402	Murata
L1	1	GLCLK2R201A	2.2µH	2.5mm x 2.0mm x 1.0mm	ALPS
		1269AS-H-2R2M = P2	2.2µH		Murata

Time Diagram

SWIRE Interface



Power Sequence

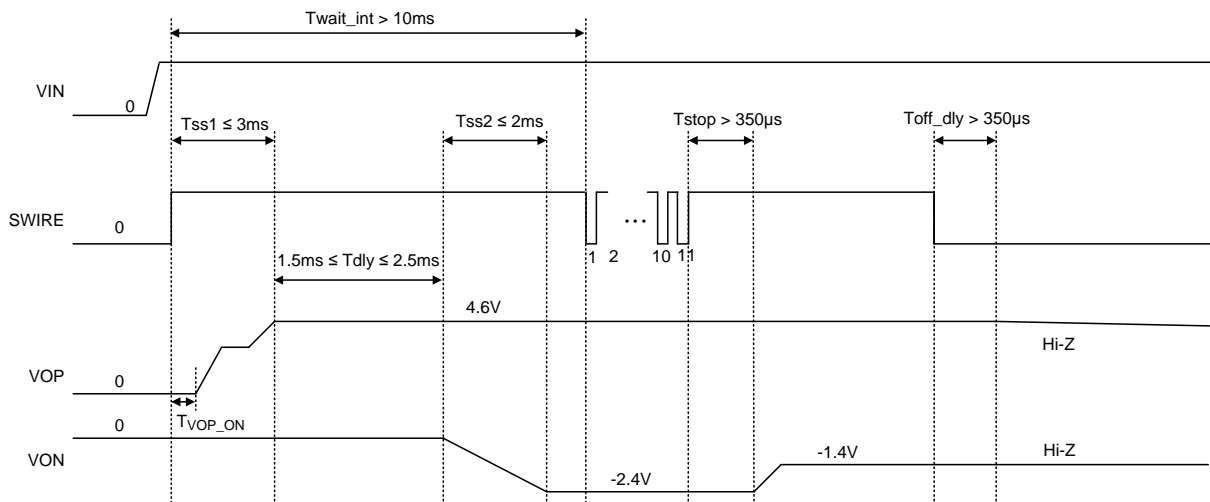

**Table 2. VON Output Voltage with SWIRE Pulse**

Pulse	VON(V)
0	-2.4 (default)
1	-2.4
2	-2.3
3	-2.2
4	-2.1
5	-2.0
6	-1.9
7	-1.8
8	-1.7
9	-1.6
10	-1.5
11	-1.4
12	-1.3
13	-1.2
14	-1.1
15	-1.0
16	-0.9
17	-0.8
18	-0.7
19	-0.6
20	0

**Table 3. VOP/VON Shutdown Discharge Selection with SWIRE Pulse**

Pulse	Discharge
21	Enable

Once pulse 21 received on SWIRE pin, the RT4723 will enable the discharge function to discharge the VOP/VON outputs for 20ms and then enter high impedance state when fault or power-off condition. The discharge function is default disabled and outputs keep high impedance state when fault or power-off condition .



Typical Operating Characteristics

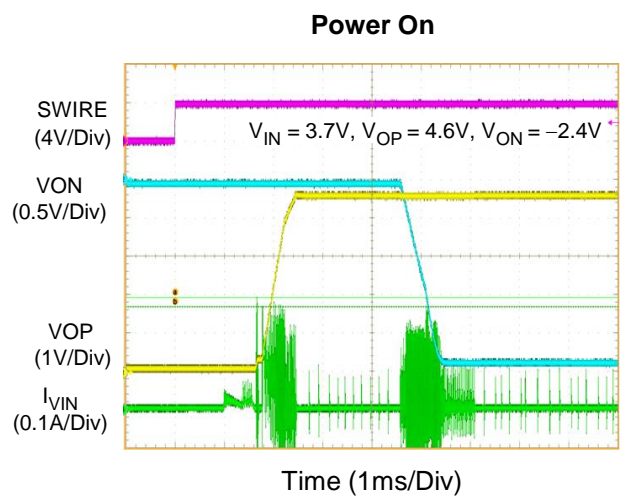
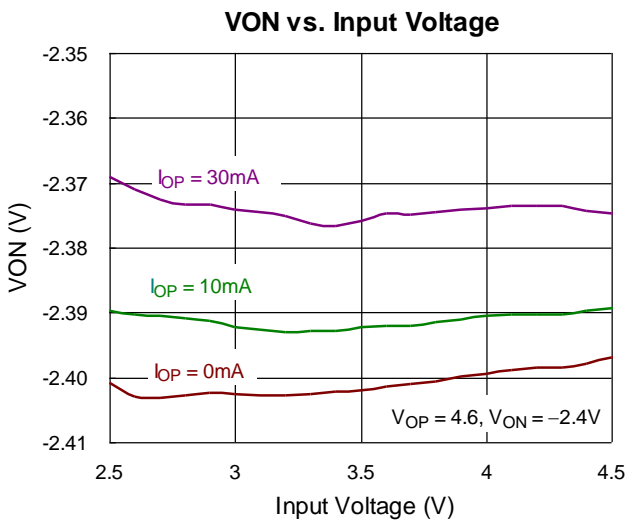
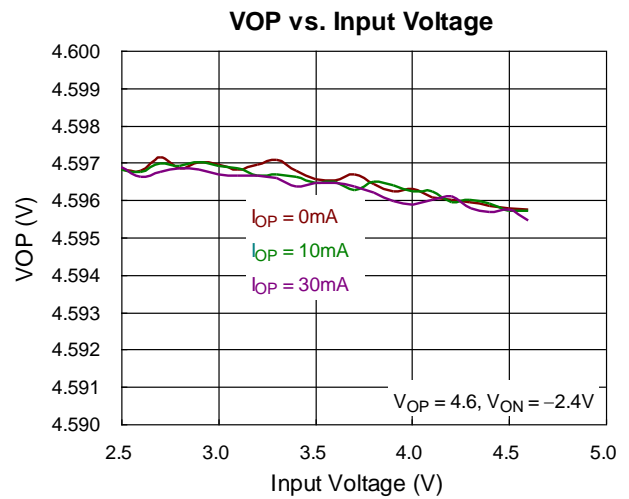
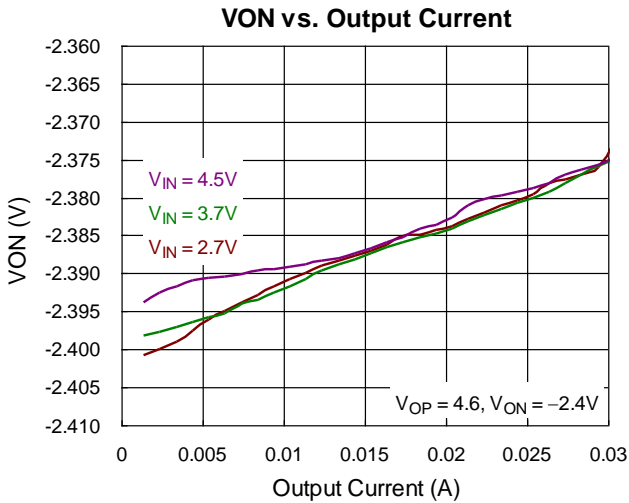
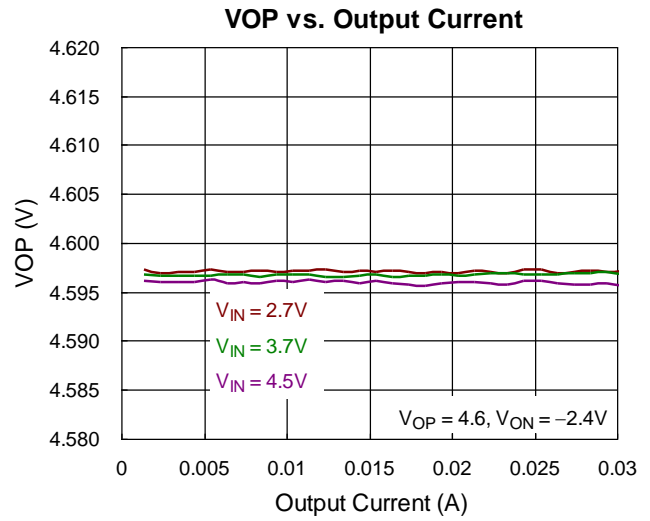
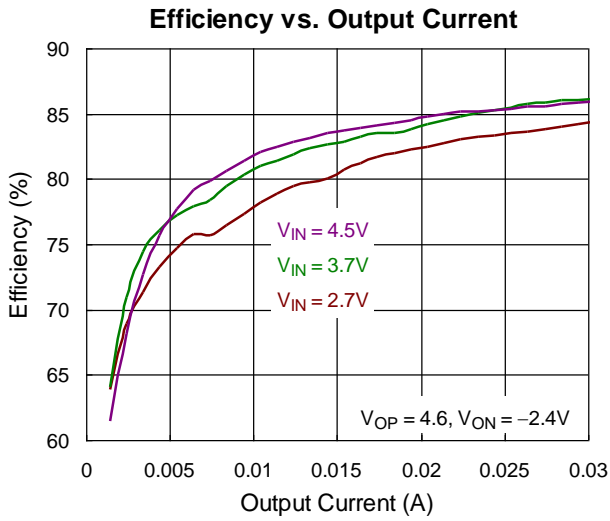

Power Off with Discharge

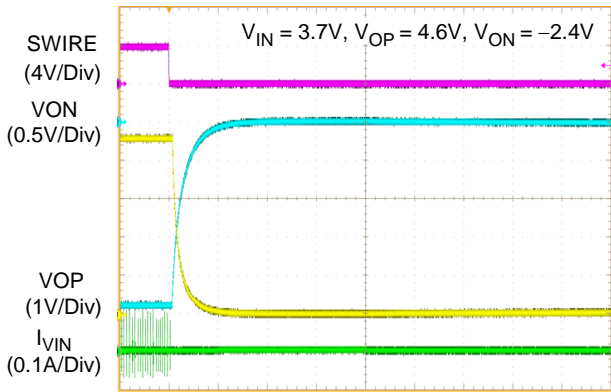

Time (5ms/Div)

Power OFF without Discharge

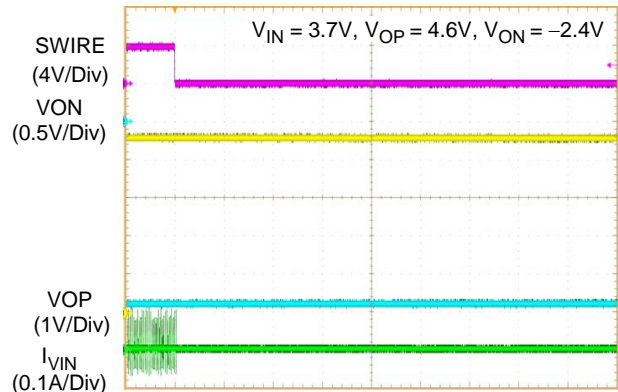

Time (10ms/Div)

Power On with SWIRE is Low

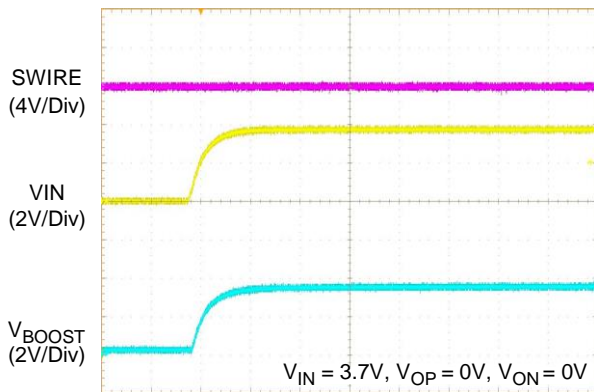

Time (10ms/Div)

Power On with SWIRE is High

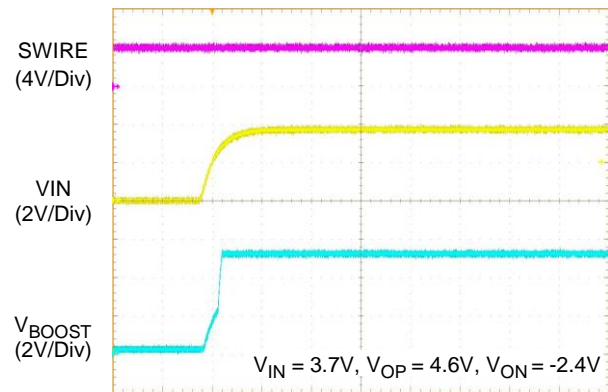

Time (10ms/Div)

Power On with SWIRE from Low to High

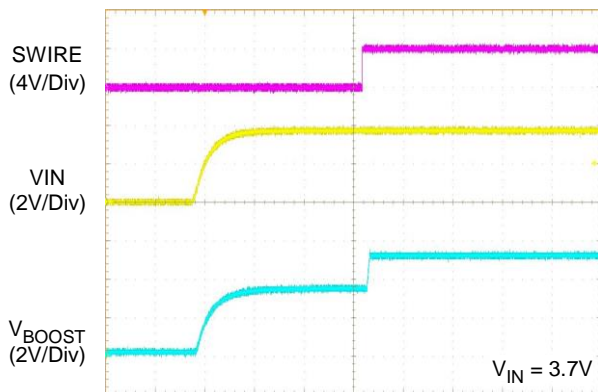

Time (10ms/Div)

**Application Information**

The RT4723 is a highly integrated Boost, LDO and inverting charge pump to generate positive and negative output voltages for AMLOED bias. It can support input voltage range from 2.5V to 4.6V and the output current up to 55mA. The VOP positive output voltage is generated from the LDO supplied from a synchronous Boost converter, and VOP is set at a typical value of 4.6V. The Boost converter output also drives an inverting charge pump controller to generate VON negative output voltage which is set at a typical value of -2.4V. The negative output voltage can be programmed through the dedicated pin which implements single wire protocol and the available voltage range is from -0.6V to -2.4V with 100mV per step.

**Input Capacitor Selection**

Input ceramic capacitor with 4.7µF capacitance is suggested for applications. For better voltage filtering, select ceramic capacitors with low ESR, X5R and X7R types are suitable because of their wider voltage and temperature ranges.

**Boost Inductor Selection**

The inductance depends on the maximum input current. As a general rule, the inductor ripple current range is 20% to 40% of the maximum input current. If 40% is selected as an example, the inductor ripple current can be calculated according to the following equations :

$$I_{IN(MAX)} = \frac{V_{OUT} \times I_{OUT(MAX)}}{\eta \times V_{IN}}$$

$$\Delta I_L = 0.4 \times I_{IN(MAX)}$$

where  $\eta$  is the efficiency of the VOP Boost converter,  $I_{IN(MAX)}$  is the maximum input current, and  $\Delta I_L$  is the inductor ripple current. The input peak current can then be obtained by adding the maximum input current with half of the inductor ripple current as shown in the following equation :

$$I_{PEAK} = 1.2 \times I_{IN(MAX)}$$

Note that the saturated current of the inductor must be greater than  $I_{PEAK}$ .

The inductance can eventually be determined according to the following equation :

$$L = \frac{\eta \times (V_{IN})^2 \times (V_{OUT} - V_{IN})}{0.4 \times (V_{OUT})^2 \times I_{OUT(MAX)} \times f_{OSC}}$$

where  $f_{OSC}$  is the switching frequency. For better system performance, a shielded inductor is preferred to avoid EMI problems.

**Boost Output Capacitor Selection**

The output ripple voltage is an important index for estimating IC performance. This portion consists of two parts. One is the product of ripple current with the ESR of the output capacitor, while the other part is formed by the charging and discharging process of the output capacitor. As shown in Figure 1,  $\Delta V_{OUT1}$  can be evaluated based on the ideal energy equalization. According to the definition of Q, the  $\Delta V_{OUT1}$  value can be calculated as the following equation :

$$Q = I_{OUT} \times D \times \frac{1}{f_{SOC}} = C_{OUT} \times \Delta V_{OUT1}$$

$$\Delta V_{OUT1} = \frac{I_{OUT} \times D}{f_{SOC} \times C_{OUT}}$$

where  $f_{SOC}$  is the switching frequency and D is the duty cycle.

Finally, taking ESR into consideration, the overall output ripple voltage can be determined by the following equation :

$$\Delta V_{OUT} = \Delta V_{ESR} + \Delta V_{OUT1} = \Delta V_{ESR} + \frac{I_{OUT} \times D}{f_{OSC} \times C_{OUT}}$$

where  $\Delta V_{ESR} = I_{C_{rms}} \times R_{CESR}$

The output capacitor,  $C_{OUT}$ , should be selected accordingly.

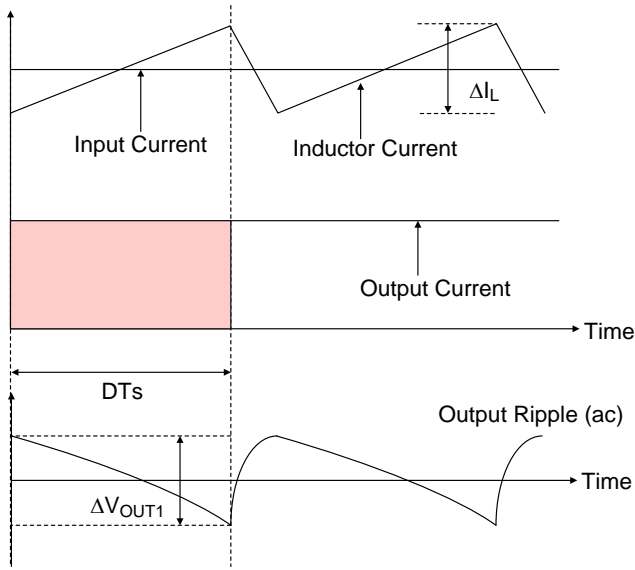

Figure 1. Output Ripple Voltage Without Contribution of ESR

**Under Voltage Lockout**

To prevent abnormal operation of the IC in low voltage condition, an under voltage lockout is included which shuts down IC operation when input voltage is lower than the specified threshold voltage.

**Soft-Start**

The RT4723 employs an internal soft-start feature to avoid high inrush current during start-up. The soft-start function is achieved by clamping the output voltage of the internal error amplifier with another voltage source that is increased slowly from zero to near VIN during the soft-start period.

**Negative Output Voltage Setting**

The Negative output voltage can be programmed by a MCU through the dedicated pin according to Table 2 “VON Output Voltage with SWIRE Pulse”.

**Shutdown Delay and Discharge**

When the SWIRE signal is logic low for more than 350μs, the IC function will be shut down. The output VOP/VON can be actively discharged to GND with discharge function enabled referring to Table 3 “VOP/VON Shutdown Discharge Selection with SWIRE Pulse”. In shutdown mode, the input supply current for the IC is less than 1μA.

**Over Current Protection**

The RT4723 includes a cycle-by-cycle current limit function which monitors the inductor current during each ON period. The power switch will be forced off to avoid large current damage once the current is over the limit level.

**Short Circuit Protection**

The RT4723 has an advanced output short-circuit protection mechanism which prevents the IC from damage by unexpected applications. When the output becomes shorted to ground, and the output voltage is under the limit level with 1ms (typ.) duration, the bias function enters shutdown mode and can only re-start normal operation after triggering the SWIRE pin.

**Over Temperature Protection**

The RT4723 equips an over temperature protection circuitry to prevent overheating due to excessive power dissipation. The OTP will shut down the bias operation when ambient temperature exceeds 140°C. Once the ambient temperature cools down by approximately 15°C, IC will automatically resume normal operation. To maintain continuous operation, the maximum junction temperature should be prevented from rising above 125°C.

**Thermal Considerations**

The junction temperature should never exceed the absolute maximum junction temperature TJ(MAX), listed under Absolute Maximum Ratings, to avoid permanent damage to the device. The maximum allowable power dissipation depends on the thermal resistance of the IC package, the PCB layout, the rate of surrounding airflow, and the difference between the junction and ambient temperatures. The maximum power dissipation can be calculated using the following formula :

$$P_{D(MAX)} = (T_{J(MAX)} - T_A) / \theta_{JA}$$

where TJ(MAX) is the maximum junction temperature, TA is the ambient temperature, and θJA is the junction-to-ambient thermal resistance.

For continuous operation, the maximum operating junction temperature indicated under Recommended Operating Conditions is 125°C. The junction-to-

ambient thermal resistance,  $\theta_{JA}$ , is highly package dependent. For a WL-CSP-15B 1.39x2.07 (BSC) package, the thermal resistance,  $\theta_{JA}$ , is 49.8°C/W on a standard JEDEC 51-7 high effective-thermal-conductivity four-layer test board. The maximum power dissipation at  $T_A = 25^\circ\text{C}$  can be calculated as below :

$$P_{D(MAX)} = (125^\circ\text{C} - 25^\circ\text{C}) / (49.8^\circ\text{C/W}) = 2\text{W for a WL-CSP-15B 1.39x2.07 (BSC) package.}$$

The maximum power dissipation depends on the operating ambient temperature for the fixed  $T_{J(MAX)}$  and the thermal resistance,  $\theta_{JA}$ . The derating curves in Figure 2 allows the designer to see the effect of rising ambient temperature on the maximum power dissipation.

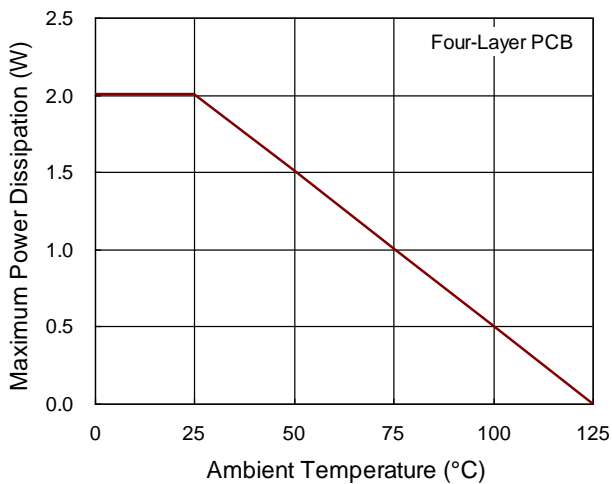

Figure 2. Derating Curve of Maximum Power Dissipation

**Layout Considerations**

For the best performance of the RT4723, the following PCB layout guidelines should be strictly followed.

- ▶ For good regulation, place the power components as close to the IC as possible. The traces should be wide and short especially for the high current output loop.
- ▶ The input and output bypass capacitor should be placed as close to the IC as possible and connected to the ground plane of the PCB.
- ▶ The flying capacitor should be placed as close to the C1P/C1N/C2P/C2N pin as possible to avoid noise injection.
- ▶ Minimize the size of the LXP node and keep the traces wide and short. Care should be taken to avoid running traces that carry any noise-sensitive signals near LXP or high-current traces.
- ▶ Separate power ground (PGND) and analog ground (GND). Connect the GND and the PGND islands at a single end. Make sure that there are no other connections between these separate ground planes.

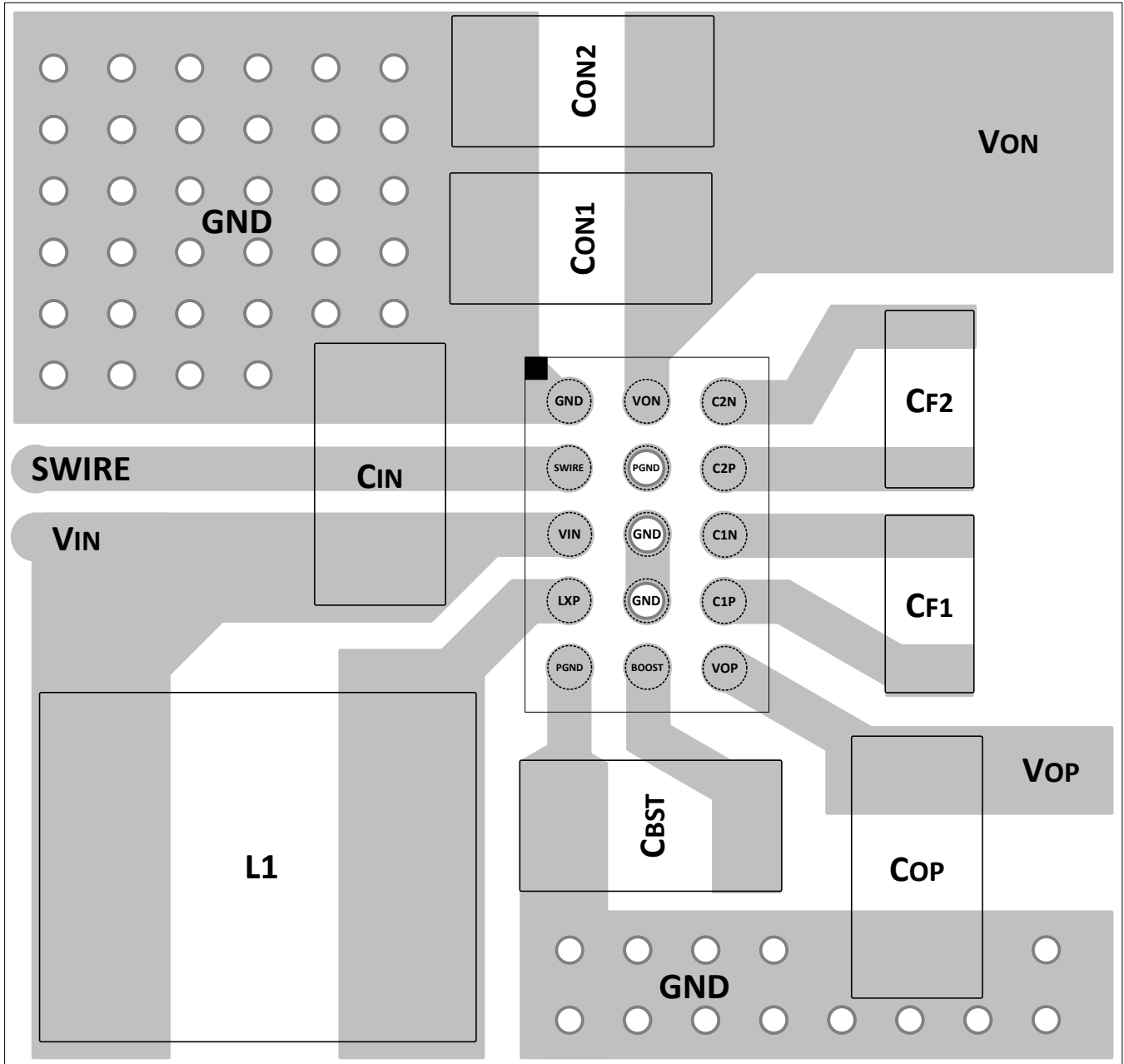
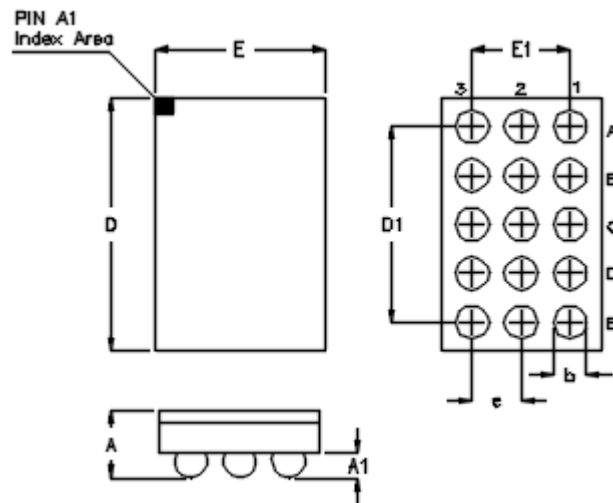

Figure 3. PCB Layout Guide

**Outline Dimension**



Symbol	Dimensions In Millimeters		Dimensions In Inches	
	Min.	Max.	Min.	Max.
A	0.500	0.600	0.020	0.024
A1	0.170	0.230	0.007	0.009
b	0.240	0.300	0.009	0.012
D	2.020	2.120	0.080	0.083
D1	1.600		0.063	
E	1.340	1.440	0.053	0.057
E1	0.800		0.031	
e	0.400		0.016	

**WL-CSP-15B 1.39x2.07 (BSC)**

**Richtek Technology Corporation**

14F, No. 8, Tai Yuen 1<sup>st</sup> Street, Chupei City

Hsinchu, Taiwan, R.O.C.

Tel: (8863)5526789

Richtek products are sold by description only. Richtek reserves the right to change the circuitry and/or specifications without notice at any time. Customers should obtain the latest relevant information and data sheets before placing orders and should verify that such information is current and complete. Richtek cannot assume responsibility for use of any circuitry other than circuitry entirely embodied in a Richtek product. Information furnished by Richtek is believed to be accurate and reliable. However, no responsibility is assumed by Richtek or its subsidiaries for its use; nor for any infringements of patents or other rights of third parties which may result from its use. No license is granted by implication or otherwise under any patent or patent rights of Richtek or its subsidiaries.

Copyright © 2019 Richtek Technology Corporation. All rights reserved. **RICHTEK** is a registered trademark of Richtek Technology Corporation.

## X-ON Electronics

Largest Supplier of Electrical and Electronic Components

*Click to view similar products for [Linear Voltage Regulators](#) category:*

*Click to view products by [Richtek](#) manufacturer:*

Other Similar products are found below :

[LV56831P-E](#) [LV5684PVD-XH](#) [MCDTSA6-2R](#) [L7815ACV-DG](#) [PQ3DZ53U](#) [LV56801P-E](#) [TLE42794G](#) [L78L05CZ/1SX](#) [L78LR05DL-MA-E](#) [636416C](#) [714954EB](#) [BA033LBSG2-TR](#) [LV5680P-E](#) [L78M15CV-DG](#) [TLS202B1MBV33HTSA1](#) [L79M05T-E](#) [TLS202A1MBVHTSA1](#) [L78LR05D-MA-E](#) [NCV317MBTG](#) [NTE7227](#) [LV5680NPVC-XH](#) [LT1054CN8](#) [MP2018GZD-5-Z](#) [MP2018GZD-33-Z](#) [MIC5281-3.3YMM](#) [MC78L06BP-AP](#) [TA48LS05F\(TE85L,F\)](#) [TA78L12F\(TE12L,F\)](#) [TC47BR5003ECT](#) [TCR2LN12,LF\(S](#) [TCR2LN28,LF\(S](#) [TCR2LN30,LF\(S](#) [TCR3DF295,LM\(CT](#) [TCR3DF40,LM\(CT](#) [BA178M20CP-E2](#) [L78M12ABDT](#) [LM7812SX/NOPB](#) [LR645N3-G-P003](#) [LR645N3-G-P013](#) [ZXTR2005P5-13](#) [SCD7812BTG](#) [TCR3DF335,LM\(CT](#) [ZXTR2012K-13](#) [TLE42994E V33](#) [ZXTR2008K-13](#) [ZXTR2005K-13](#) [L88R05DL-E](#) [ADP3300ARTZ-2.7RL7](#) [LM120K-15/883](#) [IFX54441LDVXUMA1](#)